

DAC121S101-SEP 12 ビット、マイクロパワー、RRO D/A コンバータ

1 特長

- 耐放射線特性:
 - 吸収線量 (TID): 30krad (Si)
 - シングル イベント ラッチアップ (SEL): 43MeV-cm²/mg
 - シングル イベント機能割り込み (SEFI): 43MeV-cm²/mg
- 宇宙用強化プラスチック (宇宙用 EP):
 - ASTM E595 に準拠した気体排出試験実施済み
 - VID (Vendor Item Drawing) V62/24641
 - 防衛および航空宇宙アプリケーション温度範囲をサポート: -55°C~+125°C
 - 管理されたベースライン
 - 単一のアセンブリ/テスト施設
 - 単一の製造施設
 - 長期にわたる製品ライフ サイクル
 - 製品のトレーサビリティ
- 単調性を規定
- 低消費電力動作
- レール ツー レール電圧出力
- ゼロスケール出力へのパワー オンリセット
- 広い電源電圧範囲: 2.7V~5.5V
- 小型パッケージ:
 - 8 ピン VSSOP (3mm × 3mm)
- パワーダウン機能
- 主な仕様
 - 12 ビット分解能
 - DNL: -0.15LSB, +0.35LSB (標準値)
 - 12μs 出力セトリング時間 (標準値)
 - 4mV のゼロコード誤差 (標準値)
 - フルスケール誤差: -0.07%FSR (標準値)

2 アプリケーション

- コマンドおよびデータ処理 (C と DH)
- 通信ペイロード
- 光学画像処理ペイロード
- レーダー画像処理ペイロード
- 衛星用電源システム (EPS)

3 概要

DAC121S101-SEP デバイスは、フル機能搭載の汎用 12 ビット電圧出力 D/A コンバータ (DAC) で、2.7V~5.5V の単一電源で動作でき、3.6V での電流消費はわずか 177μA (代表値) です。オンチップの出力アンプによりレール ツー レール出力スイングが可能で、3 線式のシリアル インターフェイスは規定の電源電圧範囲にわたって 30MHz までのクロック速度で動作し、標準 SPI、QSPI、MICROWIRE、DSP インターフェイスと互換性があります。

この電源電圧は DAC121S101-SEP の基準電圧となるため、可能な限り広い出力ダイナミックレンジを実現します。パワーオンリセット回路は、デバイスへの有効な書き込みが発生するまで、DAC 出力を 0V にパワーアップします。パワーダウン機能により、消費電力は 1 マイクロワット (標準値) 未満に低下します。

パッケージ情報

部品番号	パッケージ (1)	本体サイズ (2)
DAC121S101-SEP	DGK (VSSOP, 8)	3mm × 3mm

- (1) 詳細については、[セクション 10](#) を参照してください。
 (2) 本体サイズ (長さ×幅) は公称値であり、ピンは含まれません。

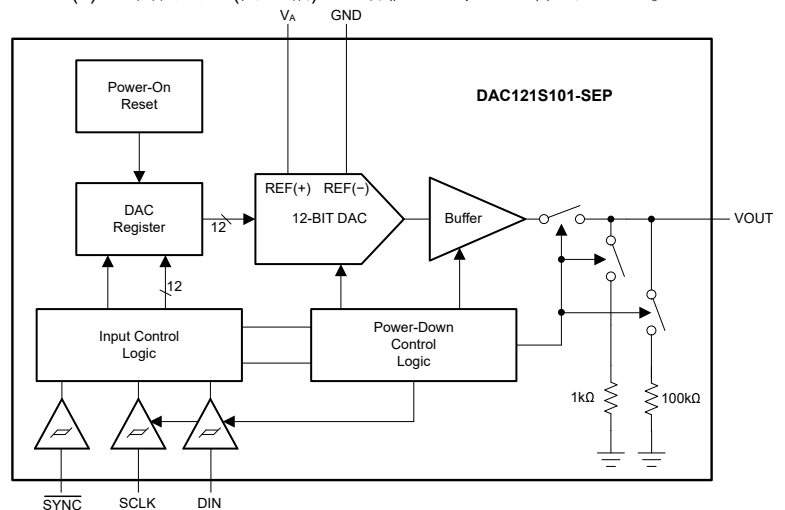

概略ブロック図



Table of Contents

1 特長.....	1	6.4 Device Functional Modes.....	16
2 アプリケーション.....	1	6.5 Programming.....	17
3 概要.....	1	7 Application and Implementation.....	18
4 Pin Configuration and Functions.....	2	7.1 Application Information.....	18
5 Specifications.....	3	7.2 Typical Application.....	19
5.1 Absolute Maximum Ratings.....	3	7.3 Power Supply Recommendations.....	20
5.2 ESD Ratings.....	3	7.4 Layout.....	21
5.3 Recommended Operating Conditions.....	3	8 Device and Documentation Support.....	22
5.4 Thermal Information.....	3	8.1 Documentation Support.....	22
5.5 Electrical Characteristics.....	4	8.2 ドキュメントの更新通知を受け取る方法.....	22
5.6 Timing Requirements.....	7	8.3 サポート・リソース.....	22
5.7 Timing Diagram.....	7	8.4 Trademarks.....	22
5.8 Typical Characteristics.....	8	8.5 静電気放電に関する注意事項.....	22
6 Detailed Description.....	14	8.6 用語集.....	22
6.1 Overview.....	14	9 Revision History.....	22
6.2 Functional Block Diagram.....	14	10 Mechanical, Packaging, and Orderable Information.....	22
6.3 Feature Description.....	14		

4 Pin Configuration and Functions



図 4-1. DAC121S101-SEP DGK Package, 8-Pin VSSOP (Top View)

表 4-1. Pin Functions

PIN		TYPE	DESCRIPTION
NO.	NAME		
1	V _A	Power	Power supply and reference input. Decouple to the GND pin.
2	NC	—	Solder this pin to a pad.
3	NC	—	Solder this pin to a pad.
4	VOUT	Output	DAC analog output voltage
5	SYNC	Input	Frame synchronization input for the data input. When this pin goes low, this pin enables the input shift register and data are transferred on the falling edges of SCLK. The DAC is updated on the 16th clock cycle unless SYNC is brought high before the 16th clock, in which case the rising edge of SYNC acts as an interrupt and the write sequence is ignored by the DAC.
6	SCLK	Input	Serial clock input. Data are clocked into the input shift register on the falling edges of this pin.
7	DIN	Input	Serial data input. Data are clocked into the 16-bit shift register on the falling edges of SCLK after the fall of SYNC.
8	GND	Ground	Ground reference for all on-chip circuitry.

5 Specifications

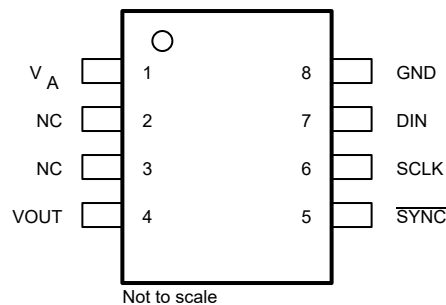
5.1 Absolute Maximum Ratings

over operating free-air temperature range (unless otherwise noted)⁽¹⁾

		MIN	MAX	UNIT
V _A	Supply voltage, V _A to GND	-0.3	6.5	V
	Voltage on any input pin to GND	-0.3	V _A + 0.3	V
	Input current at any pin ⁽²⁾		10	mA
	Package input current ⁽²⁾		20	mA
	Power consumption at T _A = 25°C		See ⁽³⁾	
	Soldering temperature, infrared, 10s ⁽⁴⁾		235	°C
T _J	Junction temperature		150	°C
T _{stg}	Storage temperature	-65	150	°C

- (1) Operation outside the *Absolute Maximum Ratings* may cause permanent device damage. *Absolute Maximum Ratings* do not imply functional operation of the device at these or any other conditions beyond those listed under *Recommended Operating Conditions*. If used outside the *Recommended Operating Conditions* but within the *Absolute Maximum Ratings*, the device may not be fully functional, and this may affect device reliability, functionality, performance, and shorten the device lifetime.
- (2) When the input voltage at any pin exceeds the power supplies (that is, less than GND, or greater than V_A), the current at that pin must be limited to 10mA. The 20mA maximum package input current rating limits the number of pins that can safely exceed the power supplies with an input current of 10mA to two.
- (3) The absolute maximum junction temperature (T_{JMAX}) for this device is 150°C. The maximum allowable power dissipation is dictated by T_{JMAX}, the junction-to-ambient thermal resistance (θ_{JA}), and the ambient temperature (T_A), and can be calculated using the formula P_{DMAX} = (T_{JMAX} - T_A) / θ_{JA}. The values for maximum power dissipation will be reached only when the device is operated in a severe fault condition (for example, when input or output pins are driven beyond the power supply voltages, or the power supply polarity is reversed). Obviously, such conditions must always be avoided.
- (4) See the section entitled *Surface Mount* found in any post 1986 National Semiconductor Linear Data Book for methods of soldering surface mount devices.

5.2 ESD Ratings

			VALUE	UNIT
V _(ESD)	Electrostatic discharge	Human body model (HBM), per ANSI/ESDA/JEDEC JS-001, all pins ⁽¹⁾	±2500	V
		Charged device model (CDM), per JEDEC specification JESD22-C101, all pins ⁽²⁾	±500	

- (1) JEDEC document JEP155 states that 500V HBM allows safe manufacturing with a standard ESD control process.
- (2) JEDEC document JEP157 states that 250V CDM allows safe manufacturing with a standard ESD control process.

5.3 Recommended Operating Conditions

over operating free-air temperature range (unless otherwise noted)

		MIN	NOM	MAX	UNIT
V _A	Supply voltage to GND	2.7		5.5	V
	Any input voltage to GND ⁽¹⁾	-0.1		(V _A + 0.1)	V
C _L	Output load capacitance	0		1500	pF
f _{SCLK}	SCLK frequency			30	MHz
T _A	Operating ambient temperature	-55		125	°C

- (1) Errors in the conversion result can occur if any input goes greater than V_A or less than GND by more than 100mV. For example, if V_A is 2.7VDC, make sure that -100mV ≤ input voltages ≤ +2.8VDC for accurate conversions.

5.4 Thermal Information

THERMAL METRIC ⁽¹⁾		DAC121S101-SEP		UNIT
		DGK (VSSOP)		
		8 PINS		
R _{θJA}	Junction-to-ambient thermal resistance	240		°C/W

- (1) For information about traditional and new thermal metrics, see the [Semiconductor and IC Package Thermal Metrics application report](#).

5.5 Electrical Characteristics

all minimum and maximum values at $-55^{\circ}\text{C} \leq T_A \leq +125^{\circ}\text{C}$ and all typical values at $T_A = 25^{\circ}\text{C}$, $2.7\text{V} \leq V_A \leq 5.5\text{V}$, DAC output pin (VOUT) loaded with resistive load ($R_L = 2\text{k}\Omega$ to AGND) and capacitive load ($C_L = 200\text{pF}$ to AGND), $f_{\text{SCLK}} = 30\text{MHz}$, and input code range: 48d to 4047d (unless otherwise noted)

PARAMETER		TEST CONDITIONS		MIN	TYP	MAX	UNIT
STATIC PERFORMANCE							
	Resolution ⁽¹⁾			12			Bits
	Monotonicity ⁽¹⁾			12			Bits
INL	Integral nonlinearity			-11	±2.6	11	LSB
DNL	Differential nonlinearity	$V_A = 2.7\text{V}$	Minimum	-0.7	-0.15		LSB
			Maximum		0.35	1	
		$V_A = 5.5\text{V}$	Minimum	-0.7	-0.15		
			Maximum		0.25	1	
ZE	Zero-code error	$I_{\text{OUT}} = 0\text{mA}$			4	16	mV
ZCED	Zero-code error drift				-20		$\mu\text{V}/^{\circ}\text{C}$
GE	Gain error	All ones loaded to DAC register			±1		%FSR
TC GE	Gain-error temperature coefficient	$V_A = 3\text{V}$			-0.7		ppm/ $^{\circ}\text{C}$
		$V_A = 5\text{V}$			-1		
FSE	Full-scale error	$I_{\text{OUT}} = 0\text{mA}$			-0.07	-1	%FSR
OUTPUT							
	Output voltage ⁽¹⁾			0		V_A	V
ZCO	Zero-code output ⁽¹⁾	$V_A = 3\text{V}, I_{\text{OUT}} = 10\mu\text{A}$				1.8	mV
		$V_A = 3\text{V}, I_{\text{OUT}} = 100\mu\text{A}$				5	
		$V_A = 5\text{V}, I_{\text{OUT}} = 10\mu\text{A}$				3.7	
		$V_A = 5\text{V}, I_{\text{OUT}} = 100\mu\text{A}$				5.4	
FSO	Full-scale output ⁽¹⁾	$V_A = 3\text{V}, I_{\text{OUT}} = 10\mu\text{A}$				2.997	V
		$V_A = 3\text{V}, I_{\text{OUT}} = 100\mu\text{A}$				2.99	
		$V_A = 5\text{V}, I_{\text{OUT}} = 10\mu\text{A}$				4.995	
		$V_A = 5\text{V}, I_{\text{OUT}} = 100\mu\text{A}$				4.992	
C_L	Capacitive load ⁽¹⁾	$R_L = \infty$				1500	pF
I_{OS}	Short-circuit current ⁽¹⁾	$V_A = 5\text{V}, V_{\text{OUT}} = 0\text{V}, \text{DAC code} = \text{FFFh}$				-63	mA
		$V_A = 3\text{V}, V_{\text{OUT}} = 0\text{V}, \text{DAC code} = \text{FFFh}$				-50	
		$V_A = 5\text{V}, V_{\text{OUT}} = 5\text{V}, \text{DAC code} = 000\text{h}$				74	
		$V_A = 3\text{V}, V_{\text{OUT}} = 3\text{V}, \text{DAC code} = 000\text{h}$				53	
	DC output impedance ⁽¹⁾					1.3	Ω

5.5 Electrical Characteristics (続き)

all minimum and maximum values at $-55^{\circ}\text{C} \leq T_A \leq +125^{\circ}\text{C}$ and all typical values at $T_A = 25^{\circ}\text{C}$, $2.7\text{V} \leq V_A \leq 5.5\text{V}$, DAC output pin (VOUT) loaded with resistive load ($R_L = 2\text{k}\Omega$ to AGND) and capacitive load ($C_L = 200\text{pF}$ to AGND), $f_{\text{SCLK}} = 30\text{MHz}$, and input code range: 48d to 4047d (unless otherwise noted)

PARAMETER		TEST CONDITIONS		MIN	TYP	MAX	UNIT
DYNAMIC PERFORMANCE							
t_s	Output voltage settling time ⁽¹⁾	400h to C00h code change	$C_L \leq 200\text{pF}$			10	μs
			$C_L = 500\text{pF}$			12	
		00Fh to FF0h code change	$C_L \leq 200\text{pF}$			8	
			$C_L = 500\text{pF}$			12	
SR	Output slew rate				1		V/ μs
	Code change glitch impulse	800h to 7FFh code change				12	nV-s
	Digital feedthrough	800h to 7FFh code change				0.5	nV-s
t_{WU}	Wake-up time	$V_A = 5\text{V}$				6	μs
		$V_A = 3\text{V}$				39	
DIGITAL INPUTS							
I_{IN}	Input current ⁽¹⁾				-1	1	μA
V_{IL}	Input low voltage ⁽¹⁾	$V_A = 5\text{V}$				0.8	V
		$V_A = 3\text{V}$				0.5	V
V_{IH}	Input high voltage ⁽¹⁾	$V_A = 5\text{V}$			2.4		V
		$V_A = 3\text{V}$			2.1		V
C_{IN}	Pin capacitance ⁽¹⁾					3	pF
POWER							
I_A	Supply current	Output unloaded, normal mode, $f_{\text{SCLK}} = 30\text{MHz}$	$V_A = 5.5\text{V}$			312	μA
			$V_A = 3.6\text{V}$			217	
		Output unloaded, normal mode, $f_{\text{SCLK}} = 20\text{MHz}$ ⁽¹⁾	$V_A = 5.5\text{V}$			279	
			$V_A = 3.6\text{V}$			197	
		Output unloaded, normal mode, $f_{\text{SCLK}} = 0\text{MHz}$ ⁽¹⁾	$V_A = 5.5\text{V}$			153	
			$V_A = 3.6\text{V}$			118	
		Output unloaded, all PD modes, $f_{\text{SCLK}} = 30\text{MHz}$ ⁽¹⁾	$V_A = 5\text{V}$			84	
			$V_A = 3\text{V}$			42	
Output unloaded, all PD modes, $f_{\text{SCLK}} = 20\text{MHz}$ ⁽¹⁾	$V_A = 5\text{V}$			56			
	$V_A = 3\text{V}$			28			
	Output unloaded, all PD modes, $f_{\text{SCLK}} = 0\text{MHz}$	$V_A = 5.5\text{V}$				0.15	1.4

5.5 Electrical Characteristics (続き)

all minimum and maximum values at $-55^{\circ}\text{C} \leq T_A \leq +125^{\circ}\text{C}$ and all typical values at $T_A = 25^{\circ}\text{C}$, $2.7\text{V} \leq V_A \leq 5.5\text{V}$, DAC output pin (VOUT) loaded with resistive load ($R_L = 2\text{k}\Omega$ to AGND) and capacitive load ($C_L = 200\text{pF}$ to AGND), $f_{\text{SCLK}} = 30\text{MHz}$, and input code range: 48d to 4047d (unless otherwise noted)

PARAMETER		TEST CONDITIONS		MIN	TYP	MAX	UNIT	
P _C	Power consumption	Output unloaded, normal mode, $f_{\text{SCLK}} = 30\text{MHz}$	$V_A = 5.5\text{V}$			1.72	mW	
			$V_A = 3.6\text{V}$			0.78		
		Output unloaded, normal mode, $f_{\text{SCLK}} = 20\text{MHz}^{(1)}$	$V_A = 5.5\text{V}$			1.53		
			$V_A = 3.6\text{V}$			0.71		
		Output unloaded, normal mode, $f_{\text{SCLK}} = 0\text{MHz}^{(1)}$	$V_A = 5.5\text{V}$			0.84		
			$V_A = 3.6\text{V}$			0.42		
		Output unloaded, all PD modes, $f_{\text{SCLK}} = 30\text{MHz}^{(1)}$	$V_A = 5\text{V}$			0.42		μW
			$V_A = 3\text{V}$			0.13		
Output unloaded, all PD modes, $f_{\text{SCLK}} = 20\text{MHz}^{(1)}$	$V_A = 5\text{V}$				0.28			
	$V_A = 3\text{V}$			0.08				
Output unloaded, all PD modes, $f_{\text{SCLK}} = 0\text{MHz}$	$V_A = 5.5\text{V}$			0.825	7.7			
I_{OUT} / I_A	Power efficiency	$I_{\text{LOAD}} = 2\text{mA}$	$V_A = 5\text{V}$			91	%	
			$V_A = 3\text{V}$			94		

(1) Specified by design and characterization, not production tested.

5.6 Timing Requirements

all input signals are specified at $2.7V \leq V_A \leq 5.5V$, $T_A = 25^\circ C$, and $f_{SCLK} = 30MHz$ (unless otherwise specified)

PARAMETER	TEST CONDITIONS	MIN	TYP	MAX	UNIT
f_{SCLK}	SCLK frequency ⁽¹⁾			30	MHz
$1/f_{SCLK}$	SCLK cycle time ⁽¹⁾	33			ns
t_H	SCLK high time ⁽¹⁾	5			ns
t_L	SCLK low time ⁽¹⁾	5			ns
t_{SUD}	D_{IN} setup time ⁽¹⁾	2.5			ns
t_{DHD}	D_{IN} hold time ⁽¹⁾	2.5			ns
t_{SUCL}	\overline{SYNC} to SCLK rising edge setup time ⁽¹⁾	-15			ns
t_{CS}	SCLK falling edge to \overline{SYNC} rising edge ⁽¹⁾	$V_A = 5V$		0	ns
		$V_A = 3V$		-2	
t_{SYNC}	\overline{SYNC} high time ⁽¹⁾	$2.7V \leq V_A \leq 3.6V$		9	ns
		$3.6V \leq V_A \leq 5.5V$		5	

(1) Specified by design and characterization, not production tested.

5.7 Timing Diagram

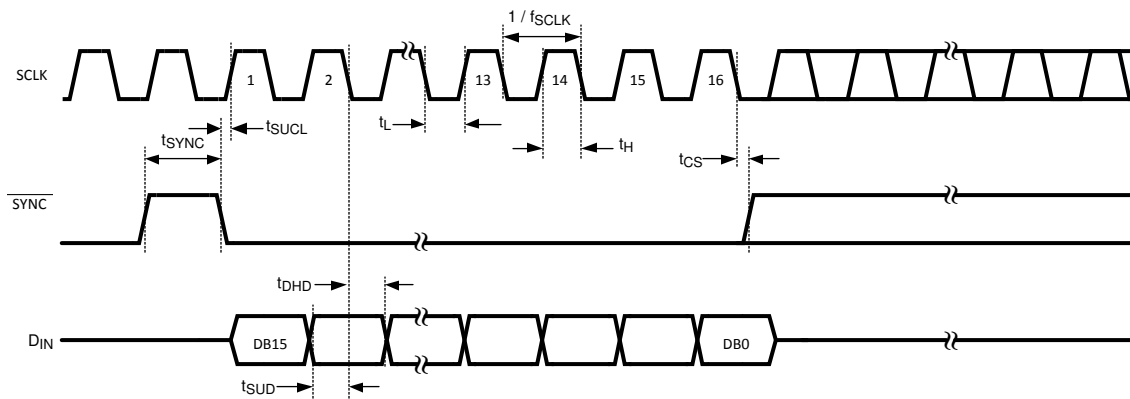

5-1. Timing Diagram

5.8 Typical Characteristics

at $f_{SCLK} = 30\text{MHz}$, $T_A = 25^\circ\text{C}$, and input code range = 48 to 4047 (unless otherwise noted)

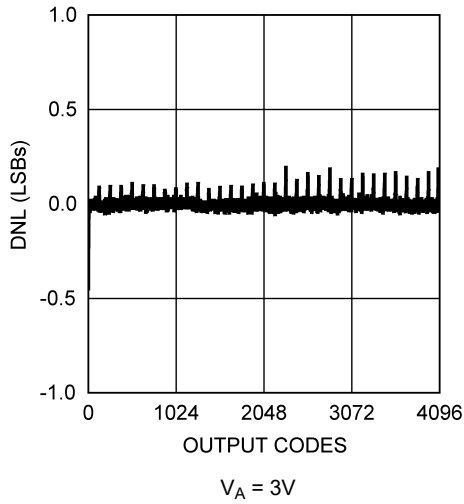

5-2. DNL vs Output Code

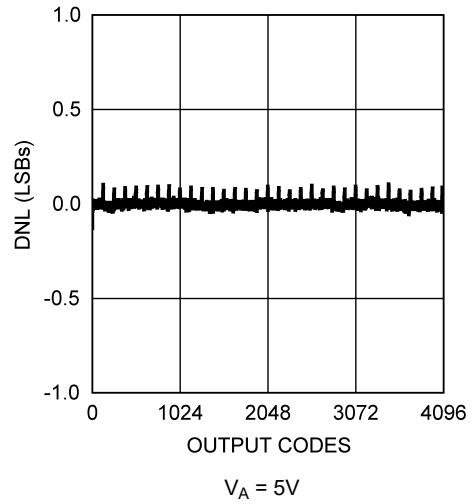

5-3. DNL vs Output Code

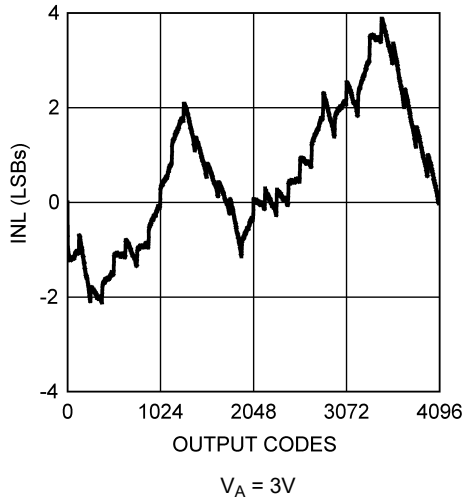

5-4. INL vs Output Code

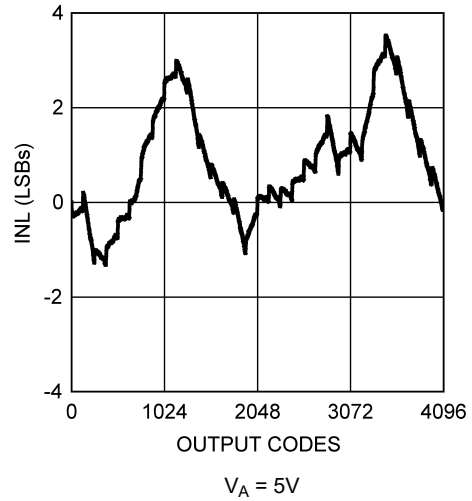

5-5. INL vs Output Code

5.8 Typical Characteristics (continued)

at $f_{SCLK} = 30\text{MHz}$, $T_A = 25^\circ\text{C}$, and input code range = 48 to 4047 (unless otherwise noted)



图 5-6. DNL vs Supply Voltage



图 5-7. INL vs Supply Voltage

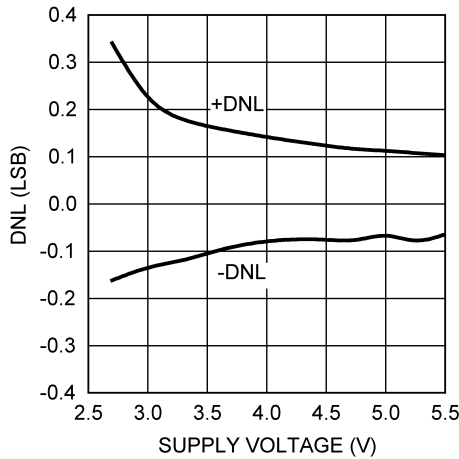

图 5-8. 3V DNL vs Clock Frequency

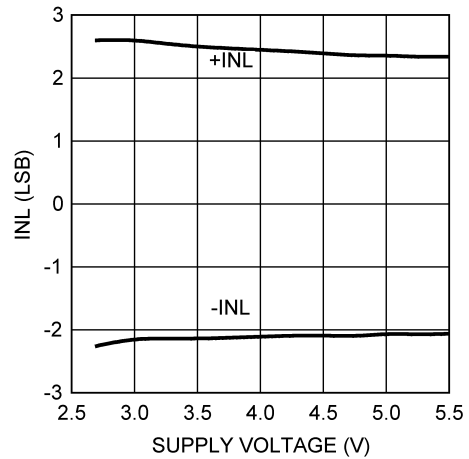

图 5-9. 5V DNL vs Clock Frequency

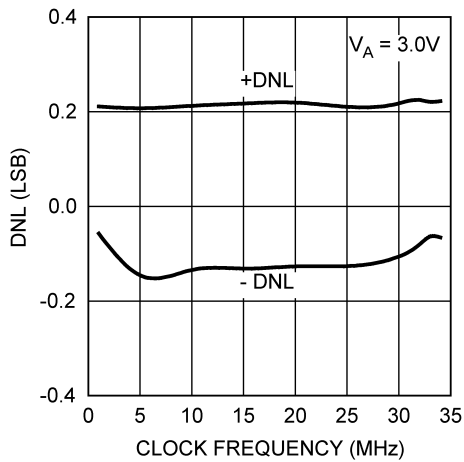

图 5-10. 3V DNL vs Clock Duty Cycle

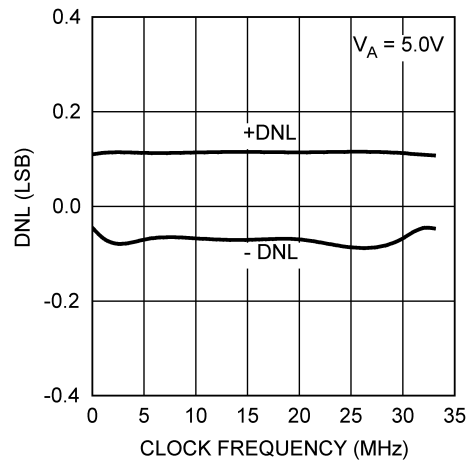

图 5-11. 5V DNL vs Clock Duty Cycle

5.8 Typical Characteristics (continued)

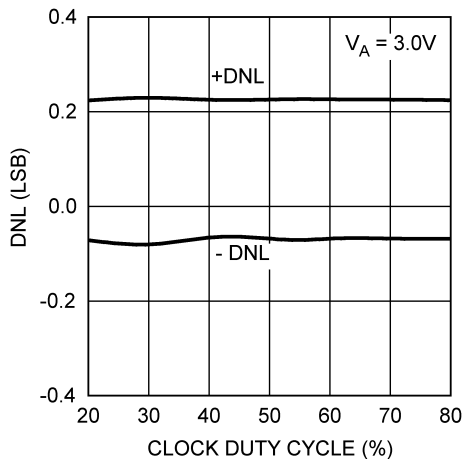
at $f_{SCLK} = 30\text{MHz}$, $T_A = 25^\circ\text{C}$, and input code range = 48 to 4047 (unless otherwise noted)



图 5-12. 3V DNL vs Temperature



图 5-13. 3V INL vs Clock Frequency

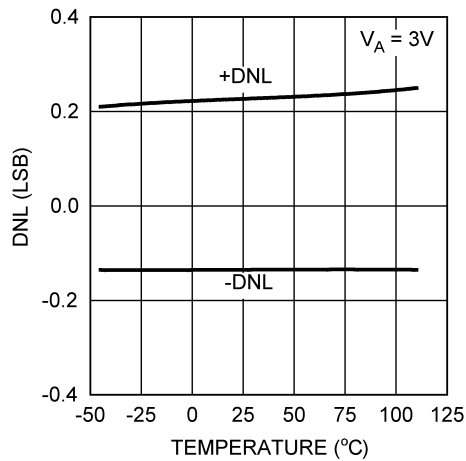

图 5-14. 5V INL vs Clock Frequency

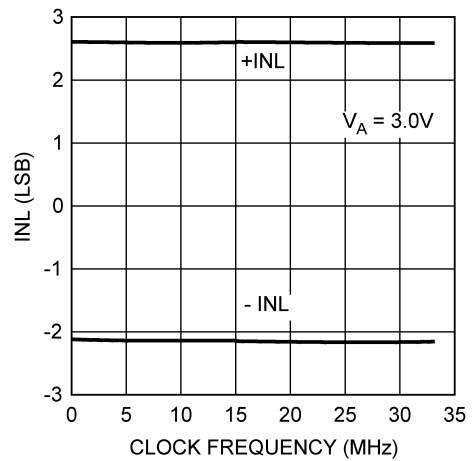

图 5-15. 3V INL vs Clock Duty Cycle

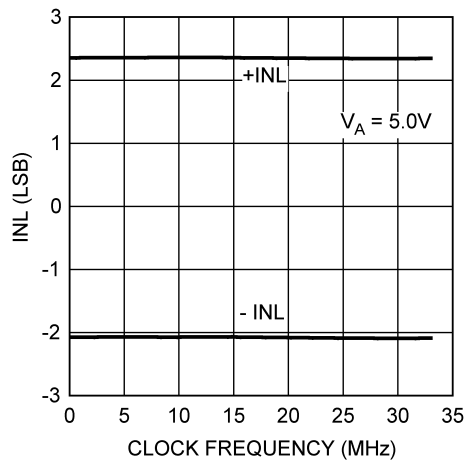

图 5-16. 5V INL vs Clock Duty Cycle

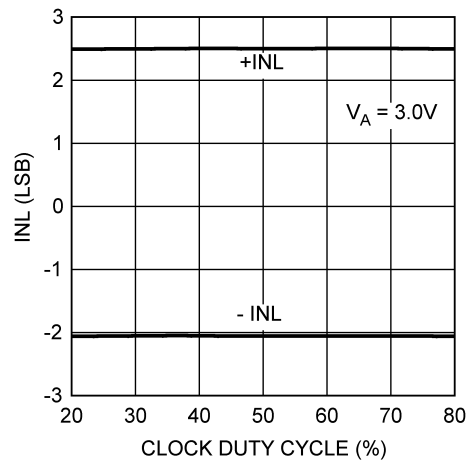

图 5-17. 3V INL vs Temperature

5.8 Typical Characteristics (continued)

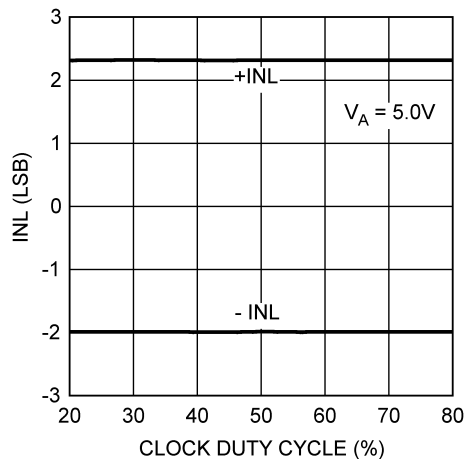
at $f_{SCLK} = 30\text{MHz}$, $T_A = 25^\circ\text{C}$, and input code range = 48 to 4047 (unless otherwise noted)

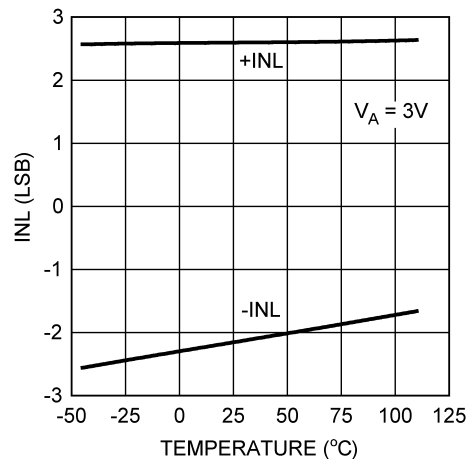
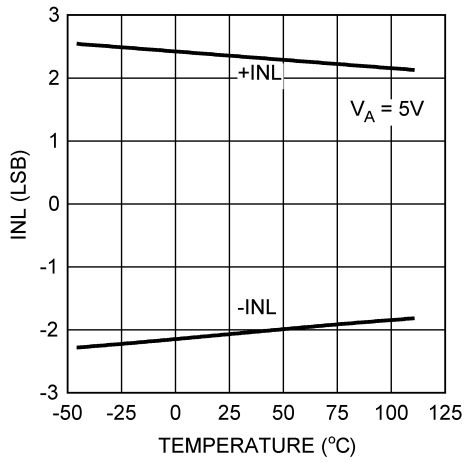

5-18. 5V INL vs Temperature

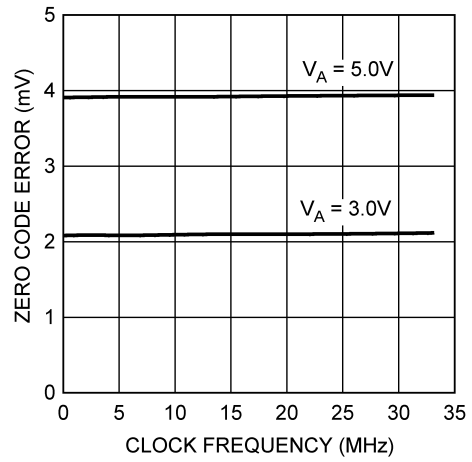

5-19. Zero Code Error vs Clock Frequency

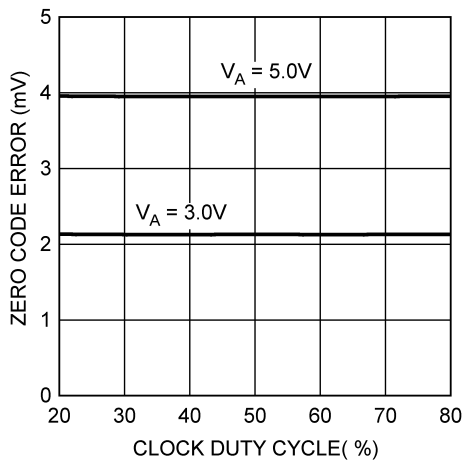

5-20. Zero Code Error vs Clock Duty Cycle

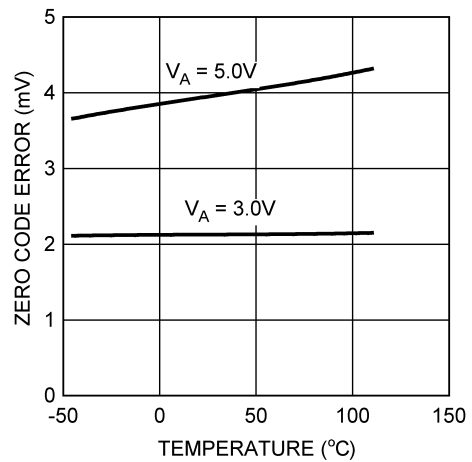

5-21. Zero Code Error vs Temperature

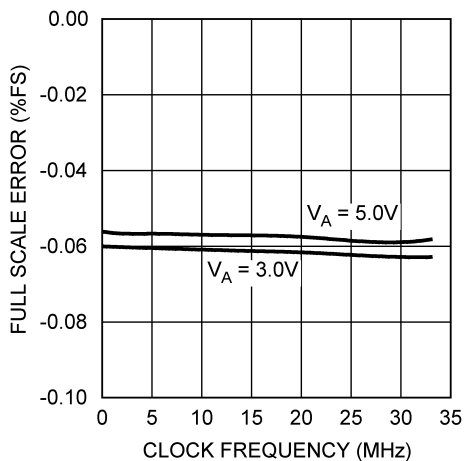

5-22. Full-Scale Error vs Clock Frequency

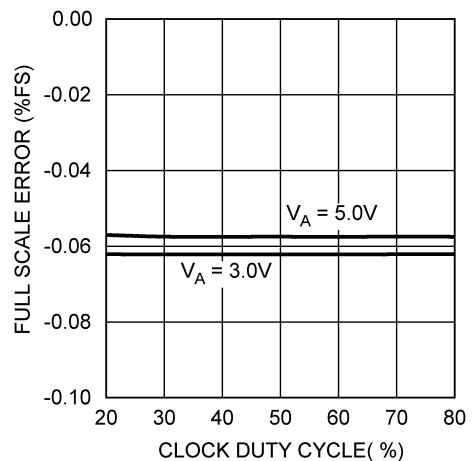

5-23. Full-Scale Error vs Clock Duty Cycle

5.8 Typical Characteristics (continued)

at $f_{SCLK} = 30\text{MHz}$, $T_A = 25^\circ\text{C}$, and input code range = 48 to 4047 (unless otherwise noted)

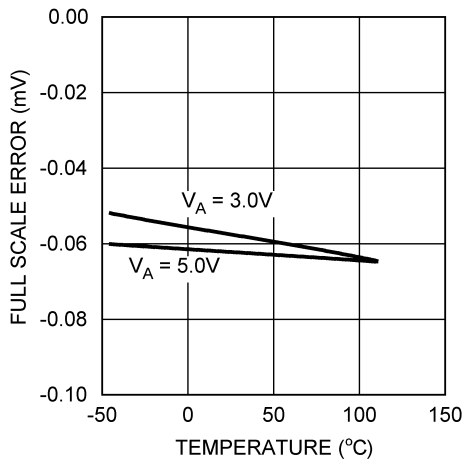

5-24. Full-Scale Error vs Temperature

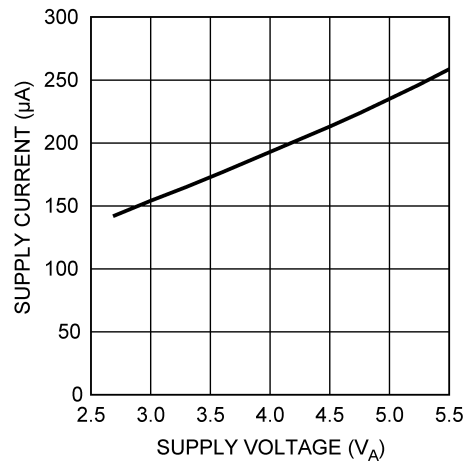

5-25. Supply Current vs Supply Voltage

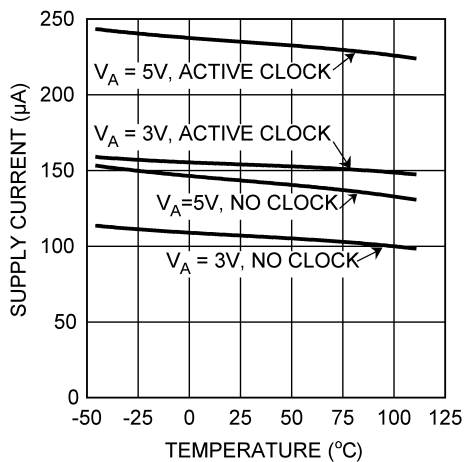

5-26. Supply Current vs Temperature

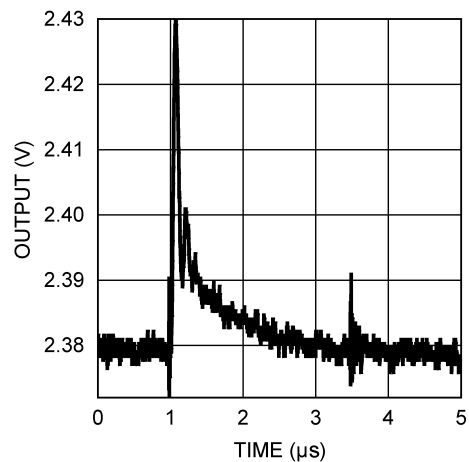

5-27. 5V Glitch Response

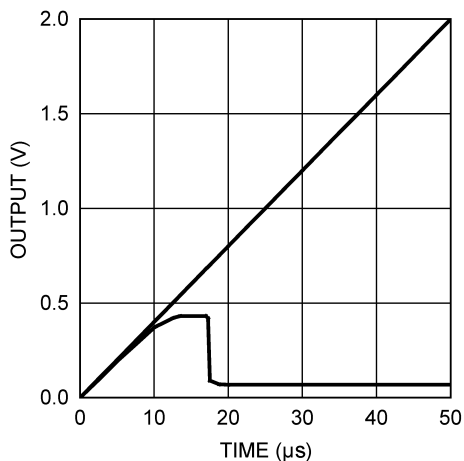

5-28. Power-On Reset

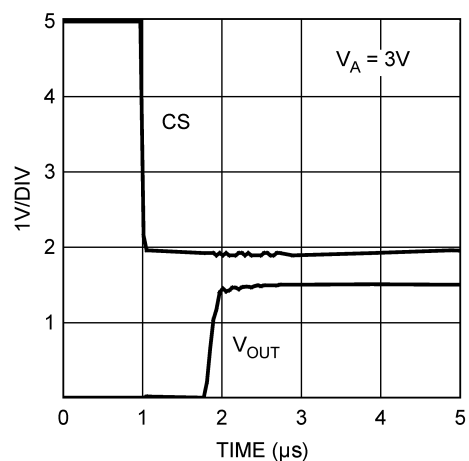

5-29. 3V Wake-Up Time

5.8 Typical Characteristics (continued)

at $f_{SCLK} = 30\text{MHz}$, $T_A = 25^\circ\text{C}$, and input code range = 48 to 4047 (unless otherwise noted)



図 5-30. 5V Wake-Up Time

6 Detailed Description

6.1 Overview

The DAC121S101-SEP device is a full-featured, general-purpose, 12-bit voltage-output digital-to-analog converter (DAC) with a 12µs (typ) settling time. Control of the output of the DAC is achieved over a 3-wire SPI. After the DAC output is set, additional communication with the DAC is not required unless the output condition must be changed. Likewise, the DAC121S101-SEP power-on state is 0V. The DAC output remains at 0V until a valid write sequence is made.

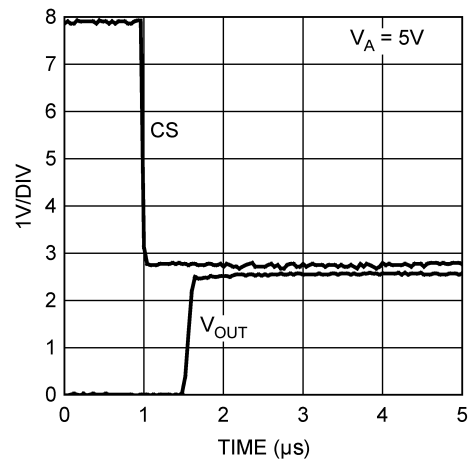
A unique benefit of the DAC121S101-SEP is the logic levels of the SPI input pins. The logic levels of SCLK, DIN, and SYNCB are independent of V_A . As a result, the DAC121S101-SEP can operate at a supply voltage (V_A) that is higher than the microcontroller controlling the DAC. This feature is advantageous in applications where the analog circuitry is being run at 5V to maximize signal-to-noise ratio, and digital logic is running at 3V to conserve power.

6.2 Functional Block Diagram

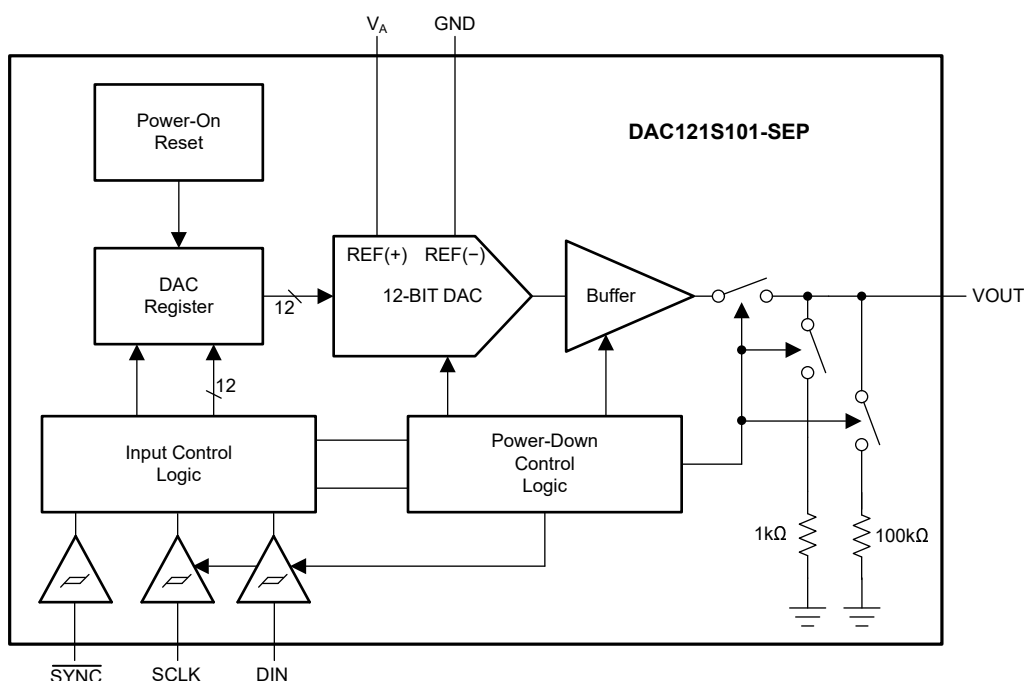

6.3 Feature Description

6.3.1 DAC Section

The DAC121S101-SEP is fabricated on a CMOS process with an architecture that consists of switches and a resistor string that are followed by an output buffer. The power supply serves as the reference voltage. The input coding is straight binary with an ideal output voltage of 式 1:

$$V_{OUT} = V_A \times \left(\frac{D}{4096} \right) \quad (1)$$

where

- D is the decimal equivalent of the binary code that is loaded into the DAC register and can take on any value between 0 and 4095.

6.3.2 Resistor String

 6-1 shows the resistor string. This string consists of 4096 equal-valued resistors with a switch at each junction of two resistors, plus a switch to ground. The code loaded into the DAC register determines which switch is closed, connecting the proper node to the amplifier. This configuration keeps the DAC monotonic.



图 6-1. DAC Resistor String

6.3.3 Output Amplifier

The output buffer amplifier is a rail-to-rail type, providing an output voltage range of 0V to V_A . All amplifiers, even rail-to-rail types, exhibit a loss of linearity as the output approaches the supply rails (0V and V_A , in this case). For this reason, linearity is specified over less than the full output range of the DAC. The output capabilities of the amplifier are described in the *Electrical Characteristics*.

6.4 Device Functional Modes

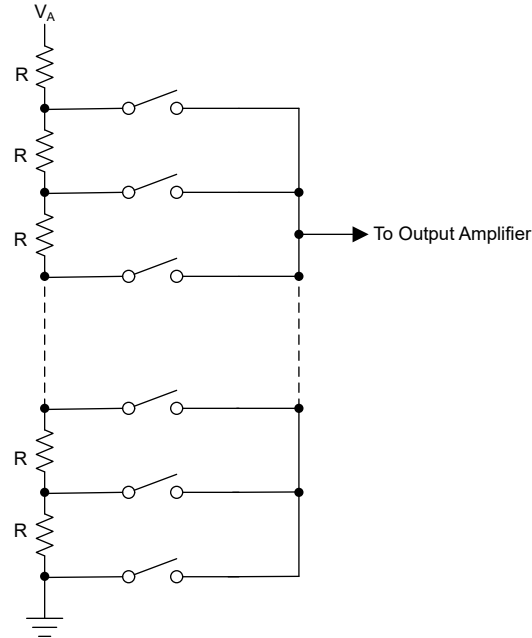
6.4.1 Power-On Reset

The power-on reset circuit controls the output voltage during power-up. Upon application of power the DAC register is filled with zeros and the output voltage is 0V and remains there until a valid write sequence is made to the DAC.

6.4.2 Power-Down Modes

表 6-1 lists the DAC121S101-SEP four modes of operation. These modes are set with two bits (DB13 and DB12) in the control register.

表 6-1. Modes of Operation

DB13	DB12	OPERATING MODE
0	0	Normal operation
0	1	Power-down with 1kΩ to GND
1	0	Power-down with 100kΩ to GND
1	1	Power-down with Hi-Z

When both DB13 and DB12 are 0, the device operates normally. For the other three possible combinations of these bits the supply current drops to the power-down level and the output is pulled down with either a 1kΩ or a 100kΩ resistor, or is in a high-impedance state, as described in 表 6-1.

The bias generator, output amplifier, the resistor string and other linear circuitry are shut down in any of the power-down modes. However, the contents of the DAC register are unaffected when in power-down; therefore, when coming out of power down, the output voltage returns to the same voltage before entering power down. Minimum power consumption is achieved in the power-down mode with SCLK disabled and SYNC and DIN idled low. The time to exit power-down (the wake-up time) is typically t_{WU} (μs) as stated in the *Dynamic Performance* section of the *Electrical Characteristics* table.

6.5 Programming

6.5.1 Serial Interface

The three-wire interface is compatible with SPI, QSPI and MICROWIRE, as well as most DSPs. See [Figure 5-1](#) for information on a write sequence.

A write sequence begins by bringing the $\overline{\text{SYNC}}$ line low. After $\overline{\text{SYNC}}$ is low, the data on the DIN line is clocked into the 16-bit serial input register on the falling edges of SCLK. On the 16th falling clock edge, the last data bit is clocked in, and the programmed function (a change in the mode of operation, a change in the DAC register contents, or both) is executed. At this point, the $\overline{\text{SYNC}}$ line can be kept low or brought high. In either case, bring the $\overline{\text{SYNC}}$ line high for the minimum specified time before the next write sequence because a falling edge of $\overline{\text{SYNC}}$ can initiate the next write cycle.

The $\overline{\text{SYNC}}$ and DIN buffers draw more current when high; therefore, idle these buffers low between write sequences to minimize power consumption.

6.5.2 Input Shift Register

The input shift register, [Figure 6-2](#), has sixteen bits. The first two bits are *don't care* bits, and are followed by two bits that determine the mode of operation (normal mode or one-of-three power-down modes). The contents of the serial input register are transferred to the DAC register on the sixteenth falling edge of SCLK. See also [Figure 5-1](#).

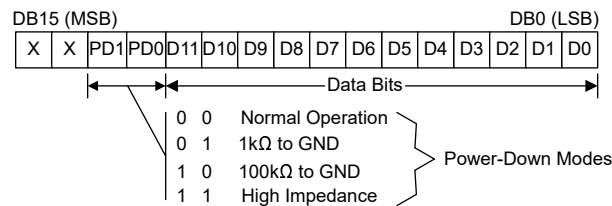

Figure 6-2. Input Register Contents

Normally, the $\overline{\text{SYNC}}$ line is kept low for at least 16 falling edges of SCLK and the DAC is updated on the 16th SCLK falling edge. However, if $\overline{\text{SYNC}}$ is brought high before the 16th falling edge, the shift register is reset and the write sequence is invalid. In this case, the DAC register is not updated, and there is no change in the mode of operation or in the output voltage.

7 Application and Implementation

注

以下のアプリケーション情報は、TI の製品仕様に含まれるものではなく、TI ではその正確性または完全性を保証いたしません。個々の目的に対する製品の適合性については、お客様の責任で判断していただくこととなります。お客様は自身の設計実装を検証しテストすることで、システムの機能を確認する必要があります。

7.1 Application Information

7.1.1 Bipolar Operation

The DAC121S101-SEP is designed for single-supply operation, and thus has a unipolar output. However, a bipolar output can be obtained with the circuit in [図 7-1](#). This circuit provides an output voltage range of $\pm 5V$.



図 7-1. Bipolar Operation

The output voltage of this circuit for any code is found using [式 2](#):

$$V_O = V_A \times \left(\frac{D}{4096}\right) \times \left(\frac{R1 + R2}{R1}\right) - V_A \times \frac{R2}{R} \quad (2)$$

where

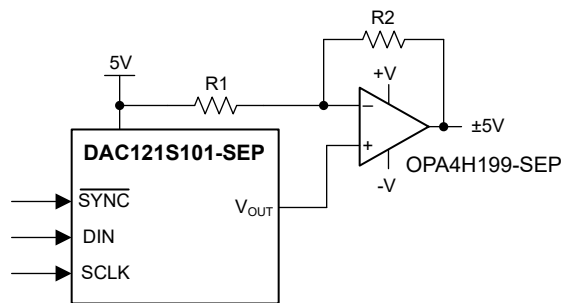
- D is the input code in decimal form.

With $V_A = 5V$ and $R1 = R2$, [式 3](#) shows the result:

$$V_O = \left(\frac{10 \times D}{4096}\right) - 5V \quad (3)$$

7.2 Typical Application



図 7-2. Pressure Sensor Gain Adjust

7.2.1 Design Requirements

Design a single supply data acquisition system capable of digitizing a pressure sensor output. In addition to digitizing the pressure sensor output, use the DAC121S101-SEP to correct gain errors in the pressure sensor output by adjusting the bias voltage to the bridge pressure sensor. 表 7-1 lists the design parameters for DAC121S101-SEP.

表 7-1. DAC121S101-SEP Design Parameters

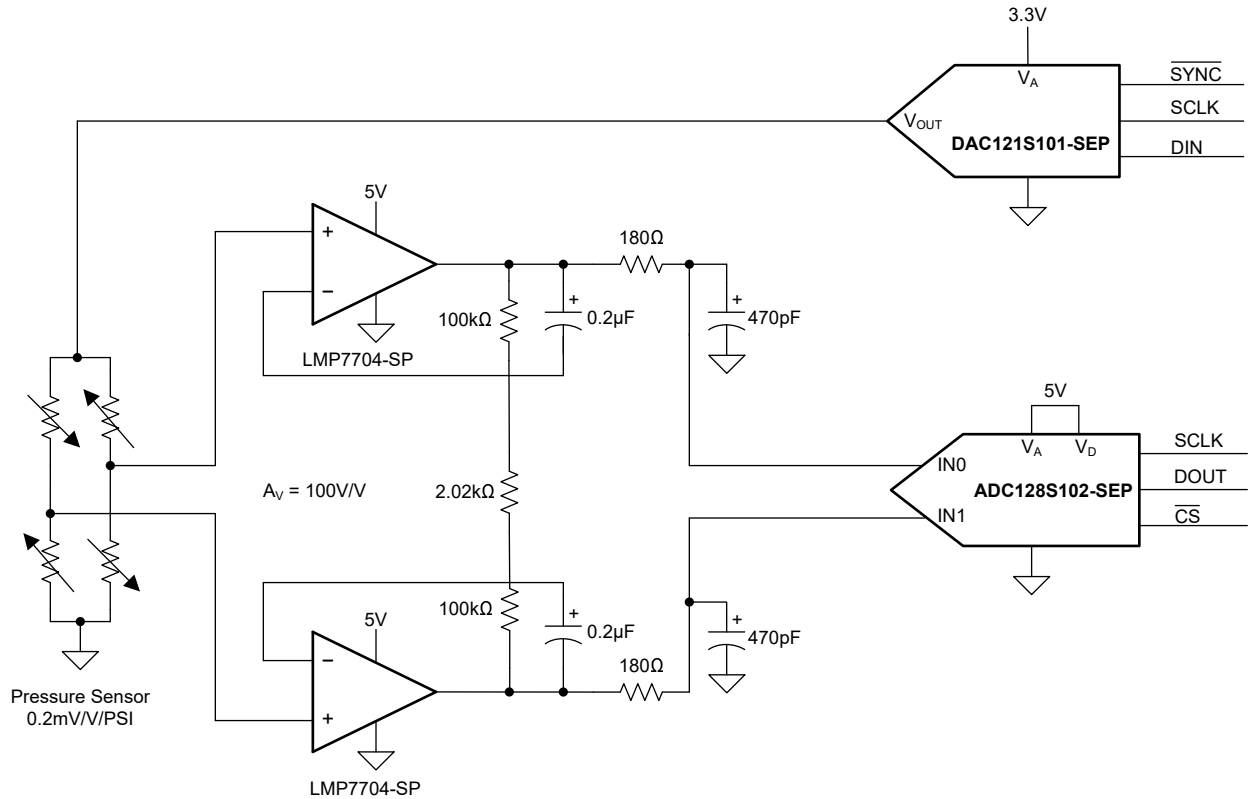
PARAMETER	VALUE
V_A	3.3V to 5V
DAC output range	0V to 5V

7.2.2 Detailed Design Procedure

式 4 shows that the output of the pressure sensor is relative to the imbalance of the resistive bridge times the output of the DAC121S101-SEP, thus providing the desired gain correction.

$$\text{Pressure Sensor Output} = \text{DAC_Output} \times \left[\left(\frac{R1}{R1 + R2} \right) - \left(\frac{R4}{R3 + R4} \right) \right] \quad (4)$$

Likewise for the ADC128S102-SEP, 式 5 shows that the ADC output is function of the pressure sensor output times relative to the ratio of the ADC input divided by the DAC121S101-SEP output voltage.

$$\text{ADC128S102-SEP Output} = \left(\text{Pressure Sensor Output} \times \left(\frac{100}{2 \times V_{REF}} \right) \right) \times 2^{12} \quad (5)$$

7.2.3 Application Curve



図 7-3. Total Unadjusted Error vs Output Code

7.3 Power Supply Recommendations

A precision analog component requires careful layout, adequate bypassing, and clean, well-regulated power supplies. The power applied to the V_A pin must be well regulated and low noise. Switching power supplies and DC/DC converters often have high-frequency glitches or spikes riding on the output voltage. In addition, digital components can create similar high-frequency spikes as internal logic states switch. This noise can easily couple into the DAC output voltage through various paths between the power connections and analog output. As with the ground connection, connect V_A to a power supply plane or trace that is separate from the connection for digital logic until V_A is connected at the power entry point.

Bypass the DAC121S101-SEP power supply with 10 μ F and 0.1 μ F capacitors, as close as possible to the device with the 0.1 μ F directly at the device supply pin. The 0.1 μ F capacitor must be a low ESL, low ESR type. Decouple the power supply of DAC121S101-SEP from noisy circuits.

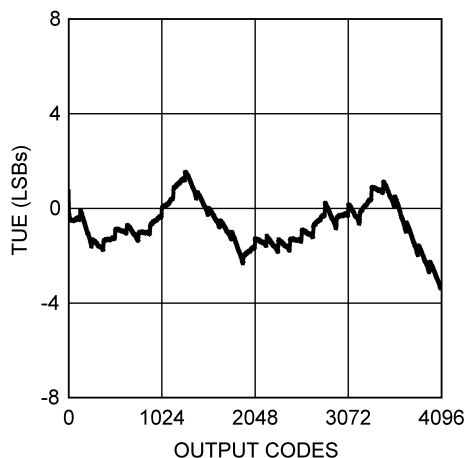
7.4 Layout

7.4.1 Layout Guidelines

For best accuracy and minimum noise, the printed-circuit-board (PCB) that contains the DAC121S101-SEP must have separate analog and digital areas. The areas are defined by the locations of the analog and digital power planes. Both of these planes must be located in the same board layer. Use a single ground plane; a single ground plane is preferred if digital return current does not flow through the analog ground area. Frequently a single ground plane design uses a *fencing* technique to prevent the mixing of analog and digital ground current. Only use separate ground planes when the fencing technique is inadequate. Connect the separate ground planes in one place, preferably near the DAC121S101-SEP. Take special care to make sure digital signals with fast edge rates do not pass over split ground planes. The digital signals must always have a continuous return path below the traces.

Avoid crossover of analog and digital signals and keep the clock and data lines on the component side of the board. The clock and data lines must have controlled impedance.

7.4.2 Layout Example

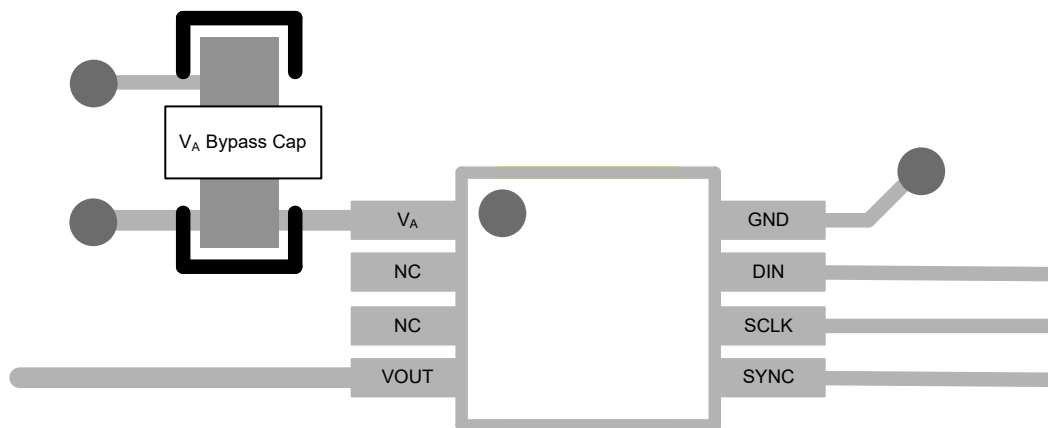

☒ 7-4. Typical Layout

8 Device and Documentation Support

8.1 Documentation Support

8.2 ドキュメントの更新通知を受け取る方法

ドキュメントの更新についての通知を受け取るには、www.tij.co.jp のデバイス製品フォルダを開いてください。[通知] をクリックして登録すると、変更されたすべての製品情報に関するダイジェストを毎週受け取ることができます。変更の詳細については、改訂されたドキュメントに含まれている改訂履歴をご覧ください。

8.3 サポート・リソース

テキサス・インスツルメンツ E2E™ サポート・フォーラムは、エンジニアが検証済みの回答と設計に関するヒントをエキスパートから迅速かつ直接得ることができる場所です。既存の回答を検索したり、独自の質問をしたりすることで、設計に必要な支援を迅速に得ることができます。

リンクされているコンテンツは、各寄稿者により「現状のまま」提供されるものです。これらはテキサス・インスツルメンツの仕様を構成するものではなく、必ずしもテキサス・インスツルメンツの見解を反映したものではありません。テキサス・インスツルメンツの[使用条件](#)を参照してください。

8.4 Trademarks

テキサス・インスツルメンツ E2E™ is a trademark of Texas Instruments.

すべての商標は、それぞれの所有者に帰属します。

8.5 静電気放電に関する注意事項



この IC は、ESD によって破損する可能性があります。テキサス・インスツルメンツは、IC を取り扱う際には常に適切な注意を払うことを推奨します。正しい取り扱いおよび設置手順に従わない場合、デバイスを破損するおそれがあります。

ESD による破損は、わずかな性能低下からデバイスの完全な故障まで多岐にわたります。精密な IC の場合、パラメータがわずかに変化するだけで公表されている仕様から外れる可能性があるため、破損が発生しやすくなっています。

8.6 用語集

[テキサス・インスツルメンツ用語集](#) この用語集には、用語や略語の一覧および定義が記載されています。

9 Revision History

資料番号末尾の英字は改訂を表しています。その改訂履歴は英語版に準じています。

DATE	REVISION	NOTES
December 2024	*	Initial Release

10 Mechanical, Packaging, and Orderable Information

The following pages include mechanical, packaging, and orderable information. This information is the most current data available for the designated devices. This data is subject to change without notice and revision of this document. For browser-based versions of this data sheet, refer to the left-hand navigation.

PACKAGING INFORMATION

Orderable part number	Status (1)	Material type (2)	Package Pins	Package qty Carrier	RoHS (3)	Lead finish/ Ball material (4)	MSL rating/ Peak reflow (5)	Op temp (°C)	Part marking (6)
DAC121S101DGKTSEP	Active	Production	VSSOP (DGK) 8	250 SMALL T&R	Yes	NIPDAU	Level-2-260C-1 YEAR	-55 to 125	121S
DAC121S101DGKTSEP.A	Active	Production	VSSOP (DGK) 8	250 SMALL T&R	Yes	NIPDAU	Level-2-260C-1 YEAR	See DAC121S101DGKTSEP	121S
V62/24641-01XE	Active	Production	VSSOP (DGK) 8	250 SMALL T&R	Yes	NIPDAU	Level-2-260C-1 YEAR	See DAC121S101DGKTSEP	121S

(1) **Status:** For more details on status, see our [product life cycle](#).

(2) **Material type:** When designated, preproduction parts are prototypes/experimental devices, and are not yet approved or released for full production. Testing and final process, including without limitation quality assurance, reliability performance testing, and/or process qualification, may not yet be complete, and this item is subject to further changes or possible discontinuation. If available for ordering, purchases will be subject to an additional waiver at checkout, and are intended for early internal evaluation purposes only. These items are sold without warranties of any kind.

(3) **RoHS values:** Yes, No, RoHS Exempt. See the [TI RoHS Statement](#) for additional information and value definition.

(4) **Lead finish/Ball material:** Parts may have multiple material finish options. Finish options are separated by a vertical ruled line. Lead finish/Ball material values may wrap to two lines if the finish value exceeds the maximum column width.

(5) **MSL rating/Peak reflow:** The moisture sensitivity level ratings and peak solder (reflow) temperatures. In the event that a part has multiple moisture sensitivity ratings, only the lowest level per JEDEC standards is shown. Refer to the shipping label for the actual reflow temperature that will be used to mount the part to the printed circuit board.

(6) **Part marking:** There may be an additional marking, which relates to the logo, the lot trace code information, or the environmental category of the part.

Multiple part markings will be inside parentheses. Only one part marking contained in parentheses and separated by a "-" will appear on a part. If a line is indented then it is a continuation of the previous line and the two combined represent the entire part marking for that device.

Important Information and Disclaimer: The information provided on this page represents TI's knowledge and belief as of the date that it is provided. TI bases its knowledge and belief on information provided by third parties, and makes no representation or warranty as to the accuracy of such information. Efforts are underway to better integrate information from third parties. TI has taken and continues to take reasonable steps to provide representative and accurate information but may not have conducted destructive testing or chemical analysis on incoming materials and chemicals. TI and TI suppliers consider certain information to be proprietary, and thus CAS numbers and other limited information may not be available for release.

In no event shall TI's liability arising out of such information exceed the total purchase price of the TI part(s) at issue in this document sold by TI to Customer on an annual basis.

OTHER QUALIFIED VERSIONS OF DAC121S101-SEP :

- Automotive : [DAC121S101-Q1](#)

NOTE: Qualified Version Definitions:

- Automotive - Q100 devices qualified for high-reliability automotive applications targeting zero defects

DGK0008A



PACKAGE OUTLINE

VSSOP - 1.1 mm max height

SMALL OUTLINE PACKAGE



4214862/A 04/2023

NOTES:

PowerPAD is a trademark of Texas Instruments.

1. All linear dimensions are in millimeters. Any dimensions in parenthesis are for reference only. Dimensioning and tolerancing per ASME Y14.5M.
2. This drawing is subject to change without notice.
3. This dimension does not include mold flash, protrusions, or gate burrs. Mold flash, protrusions, or gate burrs shall not exceed 0.15 mm per side.
4. This dimension does not include interlead flash. Interlead flash shall not exceed 0.25 mm per side.
5. Reference JEDEC registration MO-187.

EXAMPLE BOARD LAYOUT

DGK0008A

™ VSSOP - 1.1 mm max height

SMALL OUTLINE PACKAGE



LAND PATTERN EXAMPLE
EXPOSED METAL SHOWN
SCALE: 15X

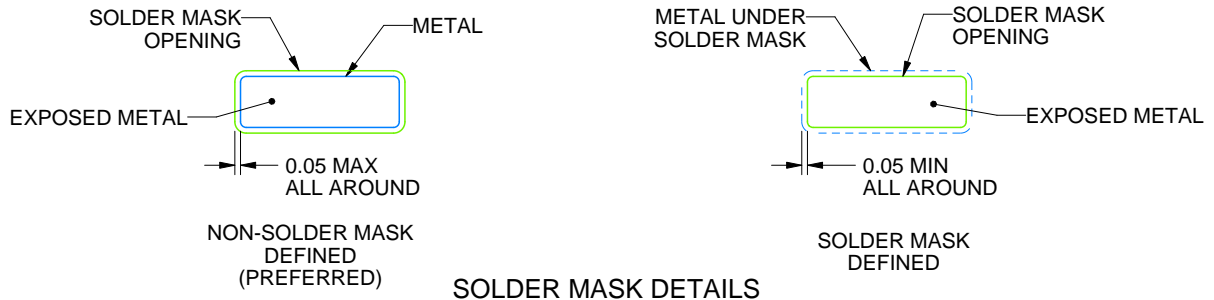

SOLDER MASK DETAILS

4214862/A 04/2023

NOTES: (continued)

6. Publication IPC-7351 may have alternate designs.
7. Solder mask tolerances between and around signal pads can vary based on board fabrication site.
8. Vias are optional depending on application, refer to device data sheet. If any vias are implemented, refer to their locations shown on this view. It is recommended that vias under paste be filled, plugged or tented.
9. Size of metal pad may vary due to creepage requirement.

EXAMPLE STENCIL DESIGN

DGK0008A

TM VSSOP - 1.1 mm max height

SMALL OUTLINE PACKAGE



SOLDER PASTE EXAMPLE
SCALE: 15X

4214862/A 04/2023

NOTES: (continued)

11. Laser cutting apertures with trapezoidal walls and rounded corners may offer better paste release. IPC-7525 may have alternate design recommendations.
12. Board assembly site may have different recommendations for stencil design.

重要なお知らせと免責事項

TI は、技術データと信頼性データ (データシートを含みます)、設計リソース (リファレンス デザインを含みます)、アプリケーションや設計に関する各種アドバイス、Web ツール、安全性情報、その他のリソースを、欠陥が存在する可能性のある「現状のまま」提供しており、商品性および特定目的に対する適合性の黙示保証、第三者の知的財産権の非侵害保証を含むいかなる保証も、明示的または黙示的にかかわらず拒否します。

これらのリソースは、TI 製品を使用する設計の経験を積んだ開発者への提供を意図したものです。(1) お客様のアプリケーションに適した TI 製品の選定、(2) お客様のアプリケーションの設計、検証、試験、(3) お客様のアプリケーションに該当する各種規格や、その他のあらゆる安全性、セキュリティ、規制、または他の要件への確実な適合に関する責任を、お客様のみが単独で負うものとし、

上記の各種リソースは、予告なく変更される可能性があります。これらのリソースは、リソースで説明されている TI 製品を使用するアプリケーションの開発の目的でのみ、TI はその使用をお客様に許諾します。これらのリソースに関して、他の目的で複製することや掲載することは禁止されています。TI や第三者の知的財産権のライセンスが付与されている訳ではありません。お客様は、これらのリソースを自身で使用した結果発生するあらゆる申し立て、損害、費用、損失、責任について、TI およびその代理人を完全に補償するものとし、TI は一切の責任を拒否します。

TI の製品は、[TI の販売条件](#)、[TI の総合的な品質ガイドライン](#)、[ti.com](#) または TI 製品などに関連して提供される他の適用条件に従い提供されます。TI がこれらのリソースを提供することは、適用される TI の保証または他の保証の放棄の拡大や変更を意味するものではありません。TI がカスタム、またはカスタマー仕様として明示的に指定していない限り、TI の製品は標準的なカタログに掲載される汎用機器です。

お客様がいかなる追加条項または代替条項を提案する場合も、TI はそれらに異議を唱え、拒否します。

Copyright © 2026, Texas Instruments Incorporated

最終更新日 : 2025 年 10 月