

DRA75x、DRA74x インフォテインメント・アプリケーション・プロセッサ シリコン・リビジョン2.0

1 デバイスの概要

1.1 特長

- インフォテインメント・アプリケーション用に設計されたアーキテクチャ
- ビデオ、画像、グラフィック処理をサポート
 - フル HD ビデオ (1920 × 1080p, 60fps)
 - 複数のビデオ入力とビデオ出力
 - 2D および 3D グラフィックス
- デュアル Arm[®] Cortex[®]-A15 マイクロプロセッサ・サブシステム
- 最大 2 つの C66x 浮動小数点 VLIW DSP
 - C67x および C64x+ と完全にオブジェクト・コード互換
 - サイクルごとに最大 32 回の 16 × 16 ビット固定小数点乗算
- 最大 2.5MB のオンチップ L3 RAM
- レベル 3 (L3) とレベル 4 (L4) の相互接続
- 2 つの DDR2/DDR3/DDR3L メモリ・インターフェイス (EMIF) モジュール
 - DDR2-800 および DDR3-1066 までをサポート
 - EMIF ごとに最大 2GB をサポート
- デュアル Arm[®] Cortex[®]-M4 画像処理ユニット (IPU)
- 最大 2 つの組み込みビジョン・エンジン (EVE)
- IVA サブシステム
- ディスプレイ・サブシステム
 - DMA エンジンを搭載し、最大 3 つのパイプラインを持つディスプレイ・コントローラ
 - HDMI[™]エンコーダ: HDMI 1.4a および DVI 1.0 準拠
- ビデオ・プロセッシング・エンジン (VPE)
- 2D グラフィック・アクセラレータ (BB2D) サブシステム
 - Vivante[®]GC320 コア
- デュアル・コア PowerVR[®] SGX544 3D GPUを利用可能
- 3 つのビデオ入力ポート (VIP) モジュール
 - 最大 10 の多重化された入力ポートをサポート
- 汎用メモリ・コントローラ (GPMC)
- 拡張ダイレクト・メモリ・アクセス (EDMA) コントローラ
- 2 ポートのギガビット・イーサネット (GMAC)
- 16 個の 32 ビット汎用タイマ
- 32 ビット MPU ウォッチドッグ・タイマ
- 5 つの I²C[™](Inter-Integrated Circuit) ポート
- HDQ[™]/ 1-Wire[®]インターフェイス
- SATA インターフェイス
- MediaLB[®](MLB) サブシステム
- 10 個の構成可能な UART/IrDA/CIR モジュール
- 4 つのマルチチャネル・シリアル・ペリフェラル・インターフェイス (McSPI)
- クワッドSPI (QSPI)
- 8 つのマルチチャネル・オーディオ・シリアル・ポート (McASP) モジュール
- SuperSpeed USB 3.0 デュアル・ロール・デバイス
- 3 つの High-Speed USB 2.0 デュアル・ロール・デバイス
- 4 つのマルチメディア・カード / セキュア・デジタル / セキュア・デジタル入出力インターフェイス (MMC[™]/SD[®]/SDIO)
- PCI-Express[®] 3.0 サブシステム、2 つの 5Gbps レーン
 - 1 つの 2 レーン Gen2 準拠ポート
 - または 2 つの 1 レーン Gen2 準拠ポート
- デュアル・コントローラ・エリア・ネットワーク (DCAN) モジュール
 - CAN 2.0B プロトコル
- 最大 247 の汎用 I/O (GPIO) ピン
- リアルタイム・クロック・サブシステム (RTCSS)
- デバイスのセキュリティ機能
 - ハードウェア暗号化アクセラレータと DMA
 - ファイアウォール
 - JTAG[®]ロック
 - セキュア・キー
 - セキュアROMおよびブート
- 電源、リセット、クロック管理 (PRCM) モジュール
- CTools テクノロジによるオンチップ・デバッグ
- 28nm CMOS テクノロジ
- 23mm × 23mm、0.8mm ピッチ、760 ピン BGA (ABC)



1.2 アプリケーション

- ヒューマン・マシン・インターフェイス (HMI)
- ナビゲーション
- デジタルおよびアナログ・ラジオ
- 後部座席用エンターテインメント
- マルチメディア再生
- Web ブラウジング
- ADAS 統合

1.3 概要

DRA75xおよびDRA74x (Jacinto 6)インフォテインメント・アプリケーション・プロセッサは、今日のインフォテインメント対応車載環境の高度な処理要求を満たすように開発されています。

このデバイスを使用して、OEM (Original-Equipment Manufacturers)およびODM (Original-Design Manufacturers)は革新的な接続技術、音声認識、オーディオ・ストリーミングなどを迅速に実装できます。Jacinto 6 デバイスは、完全に統合された混在プロセッサ・ソリューションの高い柔軟性により、高い処理性能を実現します。このデバイスには、プログラム可能なビデオ処理と、高度に統合されたペリフェラル・セットも組み込まれています。

デュアル・コアの Arm® Cortex®-A15 RISC CPU と Arm®Neon™拡張機能、TI C66x VLIW 浮動小数点 DSP コア、Vision AccelerationPac (1 つ以上の EVE 付き) によりプログラムが可能です。Armを使って、DSPおよびコプロセッサ上でプログラムされるその他のアルゴリズムから制御機能を分けて開発することで、システム・ソフトウェアをシンプルにできます。

また、TIは、Cコンパイラと、ソースコードの可視性を高めるデバッグ・インターフェイスとを含むArm、DSP、EVEコプロセッサ用開発ツール一式を提供しています。

DRA75xおよびDRA74x Jacinto 6プロセッサ・ファミリは、AEC-Q100標準に従って認定済みです。

製品情報⁽¹⁾

型番	パッケージ	本体サイズ
DRA756ABC	FCBGA (760)	23.0mm×23.0mm
DRA755ABC	FCBGA (760)	23.0mm×23.0mm
DRA754ABC	FCBGA (760)	23.0mm×23.0mm
DRA756ABC	FCBGA (760)	23.0mm×23.0mm
DRA755ABC	FCBGA (760)	23.0mm×23.0mm
DRA754ABC	FCBGA (760)	23.0mm×23.0mm
DRA752ABC	FCBGA (760)	23.0mm×23.0mm
DRA751ABC	FCBGA (760)	23.0mm×23.0mm
DRA750ABC	FCBGA (760)	23.0mm×23.0mm

(1) 詳細については、10、「メカニカル、パッケージ、および注文情報」を参照してください。

1.4 機能ブロック図

図 1-1 は、デバイスの機能ブロック図です。

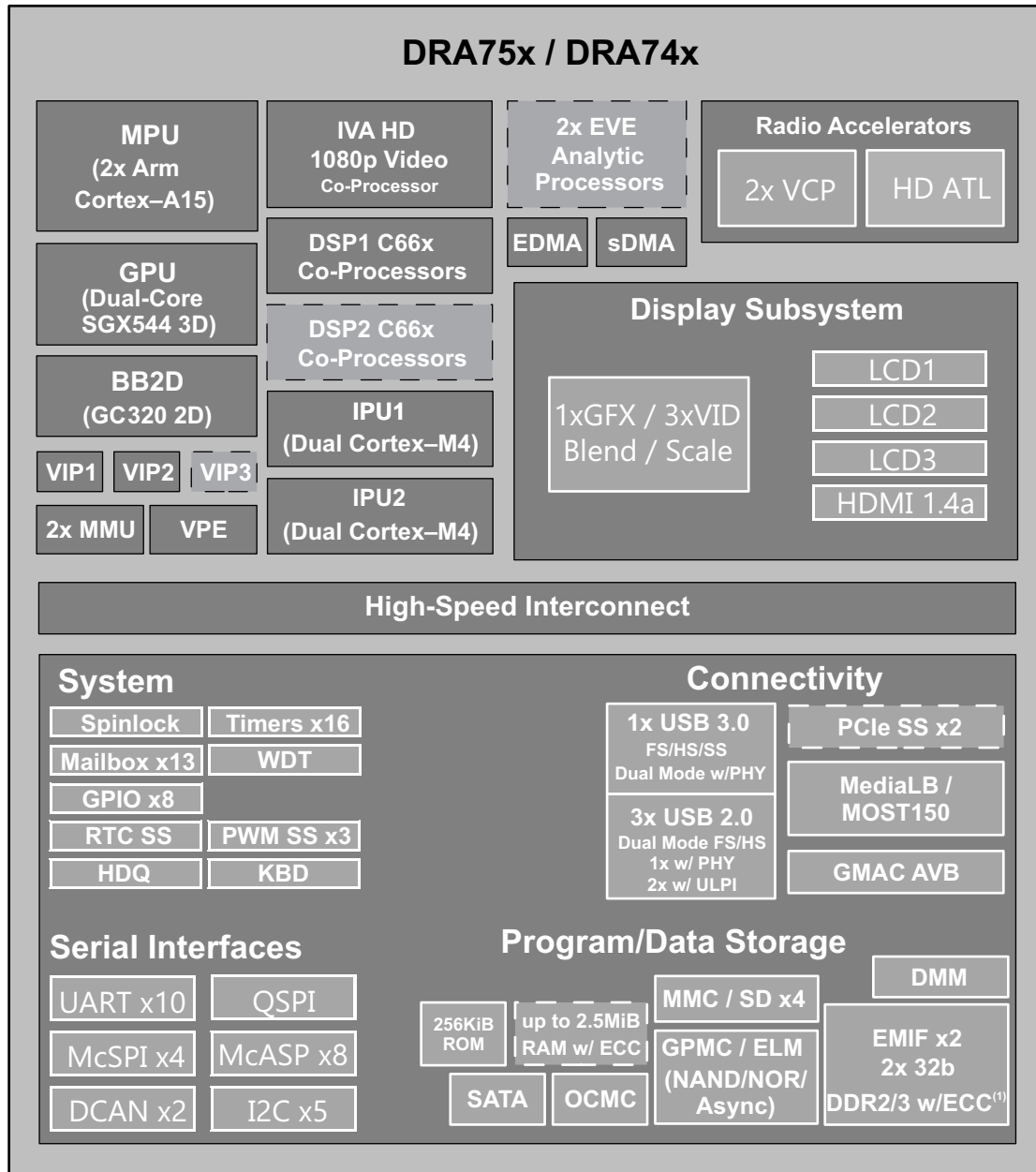

intro_001

図 1-1. DRA75x、DRA74xのブロック図

(1) ECCはEMIF1でのみ使用できます。

Table of Contents

1	デバイスの概要	1	7.11	Timers	258
1.1	特長	1	7.12	Inter-Integrated Circuit Interface (I2C)	259
1.2	アプリケーション	2	7.13	HDQ / 1-Wire Interface (HDQ1W)	261
1.3	概要	2	7.14	Universal Asynchronous Receiver Transmitter (UART)	263
1.4	機能ブロック図	3	7.15	Multichannel Serial Peripheral Interface (McSPI)	265
2	改訂履歴	5	7.16	Quad Serial Peripheral Interface (QSPI)	271
3	Device Comparison	6	7.17	Multichannel Audio Serial Port (McASP)	276
3.1	Related Products	9	7.18	Universal Serial Bus (USB)	295
4	Terminal Configuration and Functions	10	7.19	Serial Advanced Technology Attachment (SATA)	297
4.1	Terminal Assignment	10	7.20	Peripheral Component Interconnect Express (PCIe)	297
4.2	Ball Characteristics	11	7.21	Controller Area Network Interface (DCAN)	297
4.3	Multiplexing Characteristics	80	7.22	Ethernet Interface (GMAC_SW)	298
4.4	Signal Descriptions	98	7.23	Media Local Bus (MLB) interface	309
5	Specifications	140	7.24	eMMC/SD/SDIO	311
5.1	Absolute Maximum Ratings	140	7.25	General-Purpose Interface (GPIO)	337
5.2	ESD Ratings	141	7.26	Audio Tracking Logic (ATL)	338
5.3	Power on Hour (POH) Limits	142	7.27	System and Miscellaneous interfaces	338
5.4	Recommended Operating Conditions	143	7.28	Test Interfaces	338
5.5	Operating Performance Points	146	8	Applications, Implementation, and Layout	342
5.6	Power Consumption Summary	168	8.1	Introduction	342
5.7	Electrical Characteristics	168	8.2	Power Optimizations	343
5.8	Thermal Resistance Characteristics	177	8.3	Core Power Domains	357
5.9	Power Supply Sequences	178	8.4	Single-Ended Interfaces	369
6	Clock Specifications	187	8.5	Differential Interfaces	371
6.1	Input Clock Specifications	188	8.6	Clock Routing Guidelines	392
6.2	RC On-die Oscillator Clock	196	8.7	DDR2/DDR3 Board Design and Layout Guidelines	394
6.3	DPLLs, DLLs Specifications	196	9	Device and Documentation Support	429
7	Timing Requirements and Switching Characteristics	201	9.1	Device Nomenclature	429
7.1	Timing Test Conditions	201	9.2	Tools and Software	431
7.2	Interface Clock Specifications	201	9.3	Documentation Support	432
7.3	Timing Parameters and Information	201	9.4	Related Links	432
7.4	Recommended Clock and Control Signal Transition Behavior	203	9.5	Community Resources	433
7.5	Virtual and Manual I/O Timing Modes	203	9.6	商標	433
7.6	Video Input Ports (VIP)	206	9.7	静電気放電に関する注意事項	433
7.7	Display Subsystem – Video Output Ports	224	9.8	Glossary	433
7.8	Display Subsystem – High-Definition Multimedia Interface (HDMI)	236	10	Mechanical, Packaging, and Orderable Information	434
7.9	External Memory Interface (EMIF)	236	10.1	Packaging Information	434
7.10	General-Purpose Memory Controller (GPMC)	236			

2 改訂履歴

2018年11月30日発行分から2019年05月15日発行分への変更 (from E Revision (November 2018) to F Revision)	Page
• Fixed type direction to “O” for mii1_txer and mii0_txer signals in 表 4-20, GMAC Signal Descriptions	121
• Added clarification notes for EMU[1:0] connections in 表 4-23, GPIOs Signal Descriptions and 表 4-27, Debug Signal Descriptions	124
• Added MII_TXER timing to GMAC MII Timings section	300
• Updated MDIO Timing Diagram and MDIO7 parameter values	302
• Added note regarding DDR ECC solutions to 表 8-43, Supported DDR3 Device Combinations	406
• Added clarifications about validated DDR topology in 8.7.3.15, CK and ADDR_CTRL Topologies and Routing Definition	416
• Updated a note for cosmetic marks on the package	429

3 Device Comparison

表 3-1 shows a comparison between devices, highlighting the differences.

表 3-1. Device Comparison⁽⁴⁾

FEATURES		DEVICE								
		Jacinto 6 EX			Jacinto 6 EP			Jacinto 6		
		DRA756	DRA755	DRA754	DRA752	DRA751	DRA750	DRA746	DRA745	DRA744
Features										
CTRL_WKUP_STD_FUSE_DIE_ID_2[31:24] Base PN register bitfield value ⁽³⁾⁽⁴⁾		15 (0xF)	14 (0xE)	13 (0xD)	11 (0xB)	10 (0xA)	9 (0x9)	7 (0x7)	6 (0x6)	5 (0x5)
Processors/ Accelerators										
Speed Grades		P	L	J	P	L	J	P	L	J
Dual Arm Cortex-A15 Microprocessor Subsystem (MPU)	MPU core 0	Yes			Yes			Yes		
	MPU core 1	Yes			Yes			Yes		
C66x VLIW DSP	DSP1	Yes			Yes			Yes		
	DSP2	Yes			Yes			No		
BitBLT 2D Hardware Acceleration Engine (BB2D)	BB2D	Yes			Yes			Yes		
Display Subsystem	VOUT1	Yes			Yes			Yes		
	VOUT2	Yes			Yes			Yes		
	VOUT3	Yes			Yes			Yes		
	HDMI	Yes			Yes			Yes		
Embedded Vision Engine (EVE)	EVE1	Yes			No			No		
	EVE2	Yes			No			No		
Dual Arm Cortex-M4 Image Processing Unit (IPU)	IPU1	Yes			Yes			Yes		
	IPU2	Yes			Yes			Yes		
Image Video Accelerator (IVA)	IVA	Yes			Yes			Yes		
SGX544 Dual-Core 3D Graphics Processing Unit (GPU)	GPU	Yes			Yes			Yes		

表 3-1. Device Comparison⁽⁴⁾ (continued)

FEATURES			DEVICE							
			Jacinto 6 EX			Jacinto 6 EP			Jacinto 6	
			DRA756	DRA755	DRA754	DRA752	DRA751	DRA750	DRA746	DRA745
Video Input Port (VIP)	VIP1	vin1a	Yes			Yes			No	
		vin1b	Yes			Yes			No	
		vin2a	Yes			Yes			Yes	
		vin2b	Yes			Yes			Yes	
	VIP2	vin3a	Yes			Yes			Yes	
		vin3b	Yes			Yes			Yes	
		vin4a	Yes			Yes			Yes	
		vin4b	Yes			Yes			Yes	
	VIP3	vin5a	Yes			Yes			No	
		vin6a	Yes			Yes			No	
Video Processing Engine (VPE)		VPE	Yes			Yes			Yes	
Program/Data Storage										
On-Chip Shared Memory (RAM)		OCMC_RAM1	512KB			512KB			512KB	
		OCMC_RAM2	1MB			No			No	
		OCMC_RAM3	1MB			No			No	
General-Purpose Memory Controller (GPMC)		GPMC	Yes			Yes			Yes	
DDR2/DDR3 Memory Controller ⁽²⁾		EMIF1	up to 2GB (with optional SECDED)			up to 2GB (with optional SECDED)			up to 2GB	
		EMIF2	up to 2GB			up to 2GB			up to 2GB	
Dynamic Memory Manager (DMM)		DMM	Yes			Yes			Yes	
Radio Support										
Audio Tracking Logic (ATL)		ATL	Yes			Yes			Yes	
Viterbi Coprocessor (VCP)		VCP1	Yes			Yes			Yes	
		VCP2	Yes			Yes			Yes	
Peripherals										
Dual Controller Area Network Interface (DCAN)		DCAN1	Yes			Yes			Yes	
		DCAN2	Yes			Yes			Yes	
Enhanced DMA (EDMA)		EDMA	Yes			Yes			Yes	
System DMA (DMA_SYSTEM)		DMA_SYSTEM	Yes			Yes			Yes	
Ethernet Subsystem (Ethernet SS)		GMAC_SW[0]	MII, RMII, or RGMII			MII, RMII, or RGMII			MII, RMII, or RGMII	
		GMAC_SW[1]	MII, RMII, or RGMII			MII, RMII, or RGMII			MII, RMII, or RGMII	
General-Purpose I/O (GPIO)		GPIO	up to 247			up to 247			up to 247	

表 3-1. Device Comparison⁽⁴⁾ (continued)

FEATURES		DEVICE								
		Jacinto 6 EX			Jacinto 6 EP			Jacinto 6		
		DRA756	DRA755	DRA754	DRA752	DRA751	DRA750	DRA746	DRA745	DRA744
Inter-Integrated Circuit Interface (I ² C)	I2C	5			5			5		
System Mailbox Module	MAILBOX	13			13			13		
Media Local Bus Subsystem (MLBSS)	MLB	Yes			Yes			Yes		
Multichannel Audio Serial Port (McASP)	McASP1	16 serializers			16 serializers			16 serializers		
	McASP2	16 serializers			16 serializers			16 serializers		
	McASP3	4 serializers			4 serializers			4 serializers		
	McASP4	4 serializers			4 serializers			4 serializers		
	McASP5	4 serializers			4 serializers			4 serializers		
	McASP6	4 serializers			4 serializers			4 serializers		
	McASP7	4 serializers			4 serializers			4 serializers		
	McASP8	4 serializers			4 serializers			4 serializers		
MultiMedia Card/Secure Digital/Secure Digital Input Output Interface (MMC/SD/SDIO)	MMC1	1x UHSI 4b			1x UHSI 4b			1x UHSI 4b		
	MMC2	1x eMMC™ 8b			1x eMMC 8b			1x eMMC 8b		
	MMC3	1x SDIO 8b			1x SDIO 8b			1x SDIO 8b		
	MMC4	1x SDIO 4b			1x SDIO 4b			1x SDIO 4b		
PCI Express 3.0 Port with Integrated PHY	PCIe_SS1	Yes			Yes			Yes (Single-lane mode)		
	PCIe_SS2	Yes			Yes			No		
SATA	SATA	Yes			Yes			Yes		
Real-Time Clock Subsystem (RTCSS)	RTCSS	Yes			Yes			Yes		
Multichannel Serial Peripheral Interface (McSPI)	McSPI	4			4			4		
HDQ1W	HDQ1W	Yes			Yes			Yes		
Quad SPI (QSPI)	QSPI	Yes			Yes			Yes		
Spinlock Module	SPINLOCK	Yes			Yes			Yes		
Keyboard Controller (KBD)	KBD	Yes			Yes			Yes		
Timers, General-Purpose	TIMER	16			16			16		
Timer, Watchdog	WATCHDOG TIMER	Yes			Yes			Yes		
Pulse-Width Modulation Subsystem (PWMSS)	PWMSS1	Yes			Yes			Yes		
	PWMSS2	Yes			Yes			Yes		
	PWMSS3	Yes			Yes			Yes		
Universal Asynchronous Receiver/Transmitter (UART)	UART	10			10			10		

表 3-1. Device Comparison⁽⁴⁾ (continued)

FEATURES		DEVICE								
		Jacinto 6 EX			Jacinto 6 EP			Jacinto 6		
		DRA756	DRA755	DRA754	DRA752	DRA751	DRA750	DRA746	DRA745	DRA744
Universal Serial Bus (USB3.0)	USB1 (SuperSpeed, Dual-Role-Device [DRD])	Yes			Yes			Yes		
Universal Serial Bus (USB2.0)	USB2 (HighSpeed, Dual-Role-Device [DRD], with embedded HS PHY)	Yes			Yes			Yes		
	USB3 (HighSpeed, OTG2.0, with ULPI)	Yes			Yes			Yes		
	USB4 (HighSpeed, OTG2.0, with ULPI)	Yes			Yes			Yes ⁽¹⁾		

- (1) USB4 will not be supported on some pin-compatible roadmap devices. USB3 will be mapped to these balls instead. Pin compatibility can be maintained in the future by either not using USB4, or via software change to use USB4 on this device, but USB3 on these balls in the future.
- (2) In the Unified L3 memory map, there is maximum of 2GB of SDRAM space which is available to all L3 initiators including MPU (MPU, GPU, DSP, IVA, DMA, etc). Typically this space is interleaved across both EMIFs to optimize memory performance. If a system populates > 2GB of physical memory, that additional addressable space can be accessed only by the MPU via the Arm V7 Large Physical Address Extensions (LPAE).
- (3) For more details about the CTRL_WKUP_STD_FUSE_DIE_ID_2 register and Base PN bitfield, see the [DRA75x, DRA74x SoC for Automotive Infotainment Silicon Revision 2.0, 1.x](#).
- (4) X5777x is the base part number for the superset device. Software should constrain the features used to match the intended production device. The Base PN register bitfield value is 0x3F.

3.1 Related Products

Automotive Processors

DRAx Infotainment SoCs The "Jacinto 6" family of infotainment processors (DRA7xx), paired with robust software and ecosystem offering bring unprecedented feature-rich, in-vehicle infotainment, instrument cluster and telematics features to the next generation automobiles.

4 Terminal Configuration and Functions

4.1 Terminal Assignment

图 4-1 shows the ball locations for the 760 plastic ball grid array (PBGA) package and are used in conjunction with 表 4-2 through 表 4-34 to locate signal names and ball grid numbers.



图 4-1. ABC S-PBGA-N760 Package (Bottom View)

注: The following bottom balls are not connected: AF7 / AF10 / AF13 / AF16 / AF19 / AE4 / AE25 / AB26 / W3 / W26 / T3 / T26 / N3 / N26 / K3 / K26 / G3 / D4 / D25 / C10 / C13 / C16 / C19 / C22.

These balls do not exist on the package.

4.1.1 Unused Balls Connection Requirements

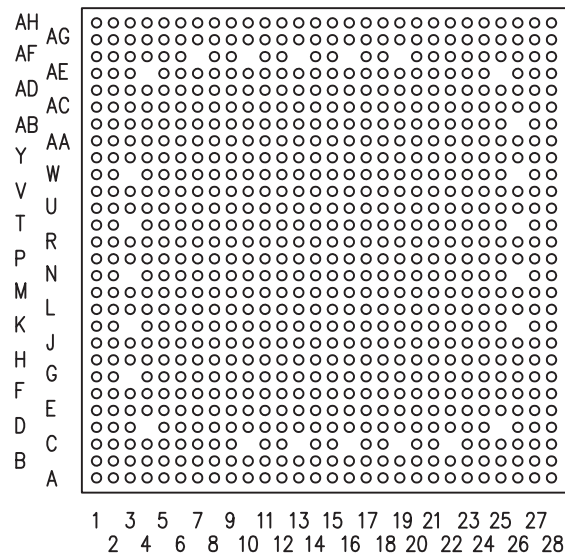
This section describes the Unused/Reserved balls connection requirements.

注: The following balls are reserved: A27 / K14 / Y5 / Y10 / B28

These balls must be left unconnected.

注: All unused power supply balls must be supplied with the voltages specified in the 5.4, *Recommended Operating Conditions*, unless alternative tie-off options are included in 4.4, *Signal Descriptions*.

表 4-1. Unused Balls Specific Connection Requirements

BALLS	CONNECTION REQUIREMENTS
AE15 / AC15 / AE14 / D20 / AD17 / AC17 / AC16 / AB16 / V27 / AH25 / AE27 / AD27 / Y28 / G28 / H27 / K27 / M28	These balls must be connected to GND through an external pull resistor if unused
E20 / D21 / E23 / C20 / C21 / V28 / F18 / AG25 / AE28 / AD28 / Y27 / G27 / H28 / K28 / M27 / F17 / C25	These balls must be connected to the corresponding power supply through an external pull resistor if unused
AF14 (rtc_iso)	This ball should be connected to the corresponding power supply through an external pull resistor if unused; or can be connected to F22 (porz) when RTC unused (level translation may be needed)

表 4-1. Unused Balls Specific Connection Requirements (continued)

BALLS	CONNECTION REQUIREMENTS
AB17 (rtc_porz)	This ball should be connected to VSS when RTC is unused; or can be connected to F22 (porz) when RTC unused (level translation may be needed)

注: All other unused signal balls **with** a Pad Configuration Register can be left unconnected with their internal pullup or pulldown resistor enabled.

注: All other unused signal balls **without** Pad Configuration Register can be left unconnected.

4.2 Ball Characteristics

表 4-2 describes the terminal characteristics and the signals multiplexed on each ball. The following list describes the table column headers:

- BALL NUMBER:** Ball number(s) on the bottom side associated with each signal on the bottom.
- BALL NAME:** Mechanical name from package device (name is taken from muxmode 0).
- SIGNAL NAME:** Names of signals multiplexed on each ball (also notice that the name of the ball is the signal name in muxmode 0).

注: 表 4-2 does not take into account the subsystem multiplexing signals. Subsystem multiplexing signals are described in 4.4, *Signal Descriptions*.

注: In the Driver off mode, the buffer is configured in high-impedance.

- 74x:** This column shows if the functionality is applicable for **DRA74x** devices. Note that the ball characteristics table presents the functionality of **DRA75x** device. An empty box means "Yes".
- MUXMODE:** Multiplexing mode number:
 - MUXMODE 0 is the primary mode; this means that when MUXMODE=0 is set, the function mapped on the pin corresponds to the name of the pin. The primary muxmode is not necessarily the default muxmode.

注: The default mode is the mode at the release of the reset; also see the RESET REL. MUXMODE column.

- MUXMODE 1 through 15 are possible muxmodes for alternate functions. On each pin, some muxmodes are effectively used for alternate functions, while some muxmodes are not used. Only MUXMODE values which correspond to defined functions should be used.
 - An empty box means Not Applicable.
- TYPE:** Signal type and direction:
 - I = Input
 - O = Output
 - IO = Input or Output
 - D = Open drain
 - DS = Differential Signaling
 - A = Analog
 - PWR = Power
 - GND = Ground
 - CAP = LDO Capacitor

7. **BALL RESET STATE:** The state of the terminal at power-on reset:
- drive 0 (OFF): The buffer drives V_{OL} (pulldown or pullup resistor not activated)
 - drive 1 (OFF): The buffer drives V_{OH} (pulldown or pullup resistor not activated)
 - OFF: High-impedance
 - PD: High-impedance with an active pulldown resistor
 - PU: High-impedance with an active pullup resistor
 - An empty box means Not Applicable
8. **BALL RESET REL. STATE:** The state of the terminal at the deactivation of the rstoutn signal (also mapped to the PRCM SYS_WARM_OUT_RST signal)
- drive 0 (OFF): The buffer drives V_{OL} (pulldown or pullup resistor not activated)
 - drive clk (OFF): The buffer drives a toggling clock (pulldown or pullup resistor not activated)
 - drive 1 (OFF): The buffer drives V_{OH} (pulldown or pullup resistor not activated)
 - OFF: High-impedance
 - PD: High-impedance with an active pulldown resistor
 - PU: High-impedance with an active pullup resistor
 - An empty box means Not Applicable

注: For more information on the CORE_PWRON_RET_RST reset signal and its reset sources, see the Power Reset and Clock Management / PRCM Reset Management Functional Description section of the Device TRM.

9. **BALL RESET REL. MUXMODE:** This muxmode is automatically configured at the release of the rstoutn signal (also mapped to the PRCM SYS_WARM_OUT_RST signal).
An empty box means Not Applicable.
10. **IO VOLTAGE VALUE:** This column describes the IO voltage value (VDDS supply).
An empty box means Not Applicable.
11. **POWER:** The voltage supply that powers the terminal IO buffers.
An empty box means Not Applicable.
12. **HYS:** Indicates if the input buffer is with hysteresis:
- Yes: With hysteresis
 - No: Without hysteresis
 - An empty box: Not Applicable

注: For more information, see the hysteresis values in [5.7, Electrical Characteristics](#).

13. **BUFFER TYPE:** Drive strength of the associated output buffer.
An empty box means Not Applicable.

注: For programmable buffer strength:

- The default value is given in [表 4-2](#).
- A note describes all possible values according to the selected muxmode.

14. **PULLUP / PULLDOWN TYPE:** Denotes the presence of an internal pullup or pulldown resistor. Pullup and pulldown resistors can be enabled or disabled via software.
- PU: Internal pullup
 - PD: Internal pulldown
 - PU/PD: Internal pullup and pulldown
 - PUx/PDy: Programmable internal pullup and pulldown
 - PDy: Programmable internal pulldown
 - An empty box means No pull

15. **DSIS:** The deselected input state (DSIS) indicates the state driven on the peripheral input (logic "0" or logic "1") when the peripheral pin function is not selected by any of the PINCNTLx registers.
- 0: Logic 0 driven on the peripheral's input signal port.
 - 1: Logic 1 driven on the peripheral's input signal port.
 - blank: Pin state driven on the peripheral's input signal port.

注: Configuring two pins to the same input signal is not supported as it can yield unexpected results. This can be easily prevented with the proper software configuration. (Hi-Z mode is not an input signal.)

注: When a pad is set into a multiplexing mode which is not defined by pin multiplexing, that pad's behavior is undefined. This should be avoided.

注意

Peripherals exposed in Ball Characteristics Table and Multiplexing Characteristics Table represent functionality of a DRA75x device. Not all exposed peripherals are supported on DRA7xx devices. For peripherals supported on DRA7xx family of products please refer to [表 3-1](#), Device Comparison.

注: Some of the DDR1 and DDR2 signals have an additional state change at the release of porz. The state that the signals change to at the release of porz is as follows:

drive 0 (OFF) for: ddr1_csn0, ddr1_ck, ddr1_nck, ddr1_nck, ddr1_casn, ddr1_rasn, ddr1_wen, ddr1_ba[2:0], ddr1_a[15:0], ddr2_csn0, ddr2_ck, ddr2_nck, ddr2_casn, ddr2_rasn, ddr2_wen, ddr2_ba[2:0], ddr2_a[15:0].

OFF for: ddr1_ecc_d[7:0], ddr1_dqm[3:0], ddr1_dqm_ecc, ddr1_dqs[3:0], ddr1_dqsn[3:0], ddr1_dqs_ecc, ddr1_dqsn_ecc, ddr1_d[31:0], ddr2_dqm[3:0], ddr2_dqs[3:0], ddr2_dqsn[3:0], ddr2_d[31:0].

表 4-2. Ball Characteristics⁽¹⁾

BALL NUMBER [1]	BALL NAME [2]	SIGNAL NAME [3]	74x [4]	MUXMODE [5]	TYPE [6]	BALL RESET STATE [7]	BALL RESET REL. STATE [8]	BALL RESET REL. MUXMODE [9]	I/O VOLTAGE VALUE [10]	POWER [11]	HYS [12]	BUFFER TYPE [13]	PULL UP/DOWN TYPE [14]	DSIS [15]
K9	cap_vbbldo_dspeve	cap_vbbldo_dspeve			CAP									
Y14	cap_vbbldo_gpu	cap_vbbldo_gpu			CAP									
R20	cap_vbbldo_iva	cap_vbbldo_iva			CAP									
J16	cap_vbbldo_mpu	cap_vbbldo_mpu			CAP									
L9	cap_vddram_core1	cap_vddram_core1			CAP									
J19	cap_vddram_core2	cap_vddram_core2			CAP									
Y15	cap_vddram_core3	cap_vddram_core3			CAP									
P19	cap_vddram_core4	cap_vddram_core4			CAP									
Y16	cap_vddram_core5	cap_vddram_core5			CAP									
J10	cap_vddram_dspeve1	cap_vddram_dspeve1			CAP									
J9	cap_vddram_dspeve2	cap_vddram_dspeve2			CAP									
Y13	cap_vddram_gpu	cap_vddram_gpu			CAP									
T20	cap_vddram_iva	cap_vddram_iva			CAP									
K16	cap_vddram_mpu1	cap_vddram_mpu1			CAP									
K19	cap_vddram_mpu2	cap_vddram_mpu2			CAP									
G19	dcan1_rx	dcan1_rx	0	IO	PU	PU	15	1.8/3.3	vddshv3	Yes	Dual Voltage LVCMOS	PU/PD	1	
		uart8_txd	2	O									0	
		mmc2_sdwp	3	I										
		sata1_led	4	O										
		hdmi1_cec	6	IO										
		gpio1_15	14	IO										
		Driver off	15	I										
G20	dcan1_tx	dcan1_tx	0	IO	PU	PU	15	1.8/3.3	vddshv3	Yes	Dual Voltage LVCMOS	PU/PD	1	
		uart8_rxd	2	I									1	
		mmc2_sdc	3	I									1	
		hdmi1_hpd	6	I										
		gpio1_14	14	IO										
		Driver off	15	I										
AD20	ddr1_a0	ddr1_a0	0	O	PD	drive 1 (OFF)		1.35/1.5/1.8	vdds_ddr1	No	LVCMOS DDR	Pux/PDy		
AC19	ddr1_a1	ddr1_a1	0	O	PD	drive 1 (OFF)		1.35/1.5/1.8	vdds_ddr1	No	LVCMOS DDR	Pux/PDy		
AD21	ddr1_a10	ddr1_a10	0	O	PD	drive 1 (OFF)		1.35/1.5/1.8	vdds_ddr1	No	LVCMOS DDR	Pux/PDy		
AD22	ddr1_a11	ddr1_a11	0	O	PD	drive 1 (OFF)		1.35/1.5/1.8	vdds_ddr1	No	LVCMOS DDR	Pux/PDy		
AC21	ddr1_a12	ddr1_a12	0	O	PD	drive 1 (OFF)		1.35/1.5/1.8	vdds_ddr1	No	LVCMOS DDR	Pux/PDy		

表 4-2. Ball Characteristics⁽¹⁾ (continued)

BALL NUMBER [1]	BALL NAME [2]	SIGNAL NAME [3]	74x [4]	MUXMODE [5]	TYPE [6]	BALL RESET STATE [7]	BALL RESET REL. STATE [8]	BALL RESET REL. MUXMODE [9]	I/O VOLTAGE VALUE [10]	POWER [11]	HYS [12]	BUFFER TYPE [13]	PULL UP/DOWN TYPE [14]	DSIS [15]
AF18	ddr1_a13	ddr1_a13		0	O	PD	drive 1 (OFF)		1.35/1.5/1.8	vdds_ddr1	No	LVC MOS DDR	Pux/PDy	
AE17	ddr1_a14	ddr1_a14		0	O	PD	drive 1 (OFF)		1.35/1.5/1.8	vdds_ddr1	No	LVC MOS DDR	Pux/PDy	
AD18	ddr1_a15	ddr1_a15		0	O	PD	drive 1 (OFF)		1.35/1.5/1.8	vdds_ddr1	No	LVC MOS DDR	Pux/PDy	
AC20	ddr1_a2	ddr1_a2		0	O	PD	drive 1 (OFF)		1.35/1.5/1.8	vdds_ddr1	No	LVC MOS DDR	Pux/PDy	
AB19	ddr1_a3	ddr1_a3		0	O	PD	drive 1 (OFF)		1.35/1.5/1.8	vdds_ddr1	No	LVC MOS DDR	Pux/PDy	
AF21	ddr1_a4	ddr1_a4		0	O	PD	drive 1 (OFF)		1.35/1.5/1.8	vdds_ddr1	No	LVC MOS DDR	Pux/PDy	
AH22	ddr1_a5	ddr1_a5		0	O	PD	drive 1 (OFF)		1.35/1.5/1.8	vdds_ddr1	No	LVC MOS DDR	Pux/PDy	
AG23	ddr1_a6	ddr1_a6		0	O	PD	drive 1 (OFF)		1.35/1.5/1.8	vdds_ddr1	No	LVC MOS DDR	Pux/PDy	
AE21	ddr1_a7	ddr1_a7		0	O	PD	drive 1 (OFF)		1.35/1.5/1.8	vdds_ddr1	No	LVC MOS DDR	Pux/PDy	
AF22	ddr1_a8	ddr1_a8		0	O	PD	drive 1 (OFF)		1.35/1.5/1.8	vdds_ddr1	No	LVC MOS DDR	Pux/PDy	
AE22	ddr1_a9	ddr1_a9		0	O	PD	drive 1 (OFF)		1.35/1.5/1.8	vdds_ddr1	No	LVC MOS DDR	Pux/PDy	
AF17	ddr1_ba0	ddr1_ba0		0	O	PD	drive 1 (OFF)		1.35/1.5/1.8	vdds_ddr1	No	LVC MOS DDR	Pux/PDy	
AE18	ddr1_ba1	ddr1_ba1		0	O	PD	drive 1 (OFF)		1.35/1.5/1.8	vdds_ddr1	No	LVC MOS DDR	Pux/PDy	
AB18	ddr1_ba2	ddr1_ba2		0	O	PD	drive 1 (OFF)		1.35/1.5/1.8	vdds_ddr1	No	LVC MOS DDR	Pux/PDy	
AC18	ddr1_casn	ddr1_casn		0	O	PD	drive 1 (OFF)		1.35/1.5/1.8	vdds_ddr1	No	LVC MOS DDR	Pux/PDy	
AG24	ddr1_ck	ddr1_ck		0	O	PD	drive clk (OFF)		1.35/1.5/1.8	vdds_ddr1	No	LVC MOS DDR	Pux/PDy	
AG22	ddr1_cke	ddr1_cke		0	O	PD	drive 0 (OFF)		1.35/1.5/1.8	vdds_ddr1	No	LVC MOS DDR	Pux/PDy	
AH23	ddr1_csn0	ddr1_csn0		0	O	PD	drive 1 (OFF)		1.35/1.5/1.8	vdds_ddr1	No	LVC MOS DDR	Pux/PDy	
AF25	ddr1_d0	ddr1_d0		0	IO	PD	PD		1.35/1.5/1.8	vdds_ddr1	No	LVC MOS DDR	Pux/PDy	
AF26	ddr1_d1	ddr1_d1		0	IO	PD	PD		1.35/1.5/1.8	vdds_ddr1	No	LVC MOS DDR	Pux/PDy	
AG27	ddr1_d10	ddr1_d10		0	IO	PD	PD		1.35/1.5/1.8	vdds_ddr1	No	LVC MOS DDR	Pux/PDy	
AF28	ddr1_d11	ddr1_d11		0	IO	PD	PD		1.35/1.5/1.8	vdds_ddr1	No	LVC MOS DDR	Pux/PDy	
AE26	ddr1_d12	ddr1_d12		0	IO	PD	PD		1.35/1.5/1.8	vdds_ddr1	No	LVC MOS DDR	Pux/PDy	

表 4-2. Ball Characteristics⁽¹⁾ (continued)

BALL NUMBER [1]	BALL NAME [2]	SIGNAL NAME [3]	74x [4]	MUXMODE [5]	TYPE [6]	BALL RESET STATE [7]	BALL RESET REL. STATE [8]	BALL RESET REL. MUXMODE [9]	I/O VOLTAGE VALUE [10]	POWER [11]	HYS [12]	BUFFER TYPE [13]	PULL UP/DOWN TYPE [14]	DSIS [15]
AC25	ddr1_d13	ddr1_d13		0	IO	PD	PD		1.35/1.5/1.8	vdds_ddr1	No	LVC MOS DDR	Pux/PDy	
AC24	ddr1_d14	ddr1_d14		0	IO	PD	PD		1.35/1.5/1.8	vdds_ddr1	No	LVC MOS DDR	Pux/PDy	
AD25	ddr1_d15	ddr1_d15		0	IO	PD	PD		1.35/1.5/1.8	vdds_ddr1	No	LVC MOS DDR	Pux/PDy	
V20	ddr1_d16	ddr1_d16		0	IO	PD	PD		1.35/1.5/1.8	vdds_ddr1	No	LVC MOS DDR	Pux/PDy	
W20	ddr1_d17	ddr1_d17		0	IO	PD	PD		1.35/1.5/1.8	vdds_ddr1	No	LVC MOS DDR	Pux/PDy	
AB28	ddr1_d18	ddr1_d18		0	IO	PD	PD		1.35/1.5/1.8	vdds_ddr1	No	LVC MOS DDR	Pux/PDy	
AC28	ddr1_d19	ddr1_d19		0	IO	PD	PD		1.35/1.5/1.8	vdds_ddr1	No	LVC MOS DDR	Pux/PDy	
AG26	ddr1_d2	ddr1_d2		0	IO	PD	PD		1.35/1.5/1.8	vdds_ddr1	No	LVC MOS DDR	Pux/PDy	
AC27	ddr1_d20	ddr1_d20		0	IO	PD	PD		1.35/1.5/1.8	vdds_ddr1	No	LVC MOS DDR	Pux/PDy	
Y19	ddr1_d21	ddr1_d21		0	IO	PD	PD		1.35/1.5/1.8	vdds_ddr1	No	LVC MOS DDR	Pux/PDy	
AB27	ddr1_d22	ddr1_d22		0	IO	PD	PD		1.35/1.5/1.8	vdds_ddr1	No	LVC MOS DDR	Pux/PDy	
Y20	ddr1_d23	ddr1_d23		0	IO	PD	PD		1.35/1.5/1.8	vdds_ddr1	No	LVC MOS DDR	Pux/PDy	
AA23	ddr1_d24	ddr1_d24		0	IO	PD	PD		1.35/1.5/1.8	vdds_ddr1	No	LVC MOS DDR	Pux/PDy	
Y22	ddr1_d25	ddr1_d25		0	IO	PD	PD		1.35/1.5/1.8	vdds_ddr1	No	LVC MOS DDR	Pux/PDy	
Y23	ddr1_d26	ddr1_d26		0	IO	PD	PD		1.35/1.5/1.8	vdds_ddr1	No	LVC MOS DDR	Pux/PDy	
AA24	ddr1_d27	ddr1_d27		0	IO	PD	PD		1.35/1.5/1.8	vdds_ddr1	No	LVC MOS DDR	Pux/PDy	
Y24	ddr1_d28	ddr1_d28		0	IO	PD	PD		1.35/1.5/1.8	vdds_ddr1	No	LVC MOS DDR	Pux/PDy	
AA26	ddr1_d29	ddr1_d29		0	IO	PD	PD		1.35/1.5/1.8	vdds_ddr1	No	LVC MOS DDR	Pux/PDy	
AH26	ddr1_d3	ddr1_d3		0	IO	PD	PD		1.35/1.5/1.8	vdds_ddr1	No	LVC MOS DDR	Pux/PDy	
AA25	ddr1_d30	ddr1_d30		0	IO	PD	PD		1.35/1.5/1.8	vdds_ddr1	No	LVC MOS DDR	Pux/PDy	
AA28	ddr1_d31	ddr1_d31		0	IO	PD	PD		1.35/1.5/1.8	vdds_ddr1	No	LVC MOS DDR	Pux/PDy	
AF24	ddr1_d4	ddr1_d4		0	IO	PD	PD		1.35/1.5/1.8	vdds_ddr1	No	LVC MOS DDR	Pux/PDy	
AE24	ddr1_d5	ddr1_d5		0	IO	PD	PD		1.35/1.5/1.8	vdds_ddr1	No	LVC MOS DDR	Pux/PDy	

表 4-2. Ball Characteristics⁽¹⁾ (continued)

BALL NUMBER [1]	BALL NAME [2]	SIGNAL NAME [3]	74x [4]	MUXMODE [5]	TYPE [6]	BALL RESET STATE [7]	BALL RESET REL. STATE [8]	BALL RESET REL. MUXMODE [9]	I/O VOLTAGE VALUE [10]	POWER [11]	HYS [12]	BUFFER TYPE [13]	PULL UP/DOWN TYPE [14]	DSIS [15]
AF23	ddr1_d6	ddr1_d6		0	IO	PD	PD		1.35/1.5/1.8	vdds_ddr1	No	LVC MOS DDR	Pux/PDy	
AE23	ddr1_d7	ddr1_d7		0	IO	PD	PD		1.35/1.5/1.8	vdds_ddr1	No	LVC MOS DDR	Pux/PDy	
AC23	ddr1_d8	ddr1_d8		0	IO	PD	PD		1.35/1.5/1.8	vdds_ddr1	No	LVC MOS DDR	Pux/PDy	
AF27	ddr1_d9	ddr1_d9		0	IO	PD	PD		1.35/1.5/1.8	vdds_ddr1	No	LVC MOS DDR	Pux/PDy	
AD23	ddr1_dqm0	ddr1_dqm0		0	O	PD	PD		1.35/1.5/1.8	vdds_ddr1	No	LVC MOS DDR	Pux/PDy	
AB23	ddr1_dqm1	ddr1_dqm1		0	O	PD	PD		1.35/1.5/1.8	vdds_ddr1	No	LVC MOS DDR	Pux/PDy	
AC26	ddr1_dqm2	ddr1_dqm2		0	O	PD	PD		1.35/1.5/1.8	vdds_ddr1	No	LVC MOS DDR	Pux/PDy	
AA27	ddr1_dqm3	ddr1_dqm3		0	O	PD	PD		1.35/1.5/1.8	vdds_ddr1	No	LVC MOS DDR	Pux/PDy	
V26	ddr1_dqm_ecc	ddr1_dqm_ecc	No	0	O	PD	PD		1.35/1.5/1.8	vdds_ddr1	No	LVC MOS DDR	Pux/PDy	
AH25	ddr1_dqs0	ddr1_dqs0		0	IO	PD	PD		1.35/1.5/1.8	vdds_ddr1		LVC MOS DDR	Pux/PDy	
AE27	ddr1_dqs1	ddr1_dqs1		0	IO	PD	PD		1.35/1.5/1.8	vdds_ddr1		LVC MOS DDR	Pux/PDy	
AD27	ddr1_dqs2	ddr1_dqs2		0	IO	PD	PD		1.35/1.5/1.8	vdds_ddr1		LVC MOS DDR	Pux/PDy	
Y28	ddr1_dqs3	ddr1_dqs3		0	IO	PD	PD		1.35/1.5/1.8	vdds_ddr1		LVC MOS DDR	Pux/PDy	
AG25	ddr1_dqsn0	ddr1_dqsn0		0	IO	PU	PU		1.35/1.5/1.8	vdds_ddr1		LVC MOS DDR	Pux/PDy	
AE28	ddr1_dqsn1	ddr1_dqsn1		0	IO	PU	PU		1.35/1.5/1.8	vdds_ddr1		LVC MOS DDR	Pux/PDy	
AD28	ddr1_dqsn2	ddr1_dqsn2		0	IO	PU	PU		1.35/1.5/1.8	vdds_ddr1		LVC MOS DDR	Pux/PDy	
Y27	ddr1_dqsn3	ddr1_dqsn3		0	IO	PU	PU		1.35/1.5/1.8	vdds_ddr1		LVC MOS DDR	Pux/PDy	
V28	ddr1_dqsn_ecc	ddr1_dqsn_ecc	No	0	IO	PU	PU		1.35/1.5/1.8	vdds_ddr1		LVC MOS DDR	Pux/PDy	
V27	ddr1_dqs_ecc	ddr1_dqs_ecc	No	0	IO	PD	PD		1.35/1.5/1.8	vdds_ddr1		LVC MOS DDR	Pux/PDy	
W22	ddr1_ecc_d0	ddr1_ecc_d0	No	0	IO	PD	PD		1.35/1.5/1.8	vdds_ddr1	No	LVC MOS DDR	Pux/PDy	
V23	ddr1_ecc_d1	ddr1_ecc_d1	No	0	IO	PD	PD		1.35/1.5/1.8	vdds_ddr1	No	LVC MOS DDR	Pux/PDy	
W19	ddr1_ecc_d2	ddr1_ecc_d2	No	0	IO	PD	PD		1.35/1.5/1.8	vdds_ddr1	No	LVC MOS DDR	Pux/PDy	
W23	ddr1_ecc_d3	ddr1_ecc_d3	No	0	IO	PD	PD		1.35/1.5/1.8	vdds_ddr1	No	LVC MOS DDR	Pux/PDy	

表 4-2. Ball Characteristics⁽¹⁾ (continued)

BALL NUMBER [1]	BALL NAME [2]	SIGNAL NAME [3]	74x [4]	MUXMODE [5]	TYPE [6]	BALL RESET STATE [7]	BALL RESET REL. STATE [8]	BALL RESET REL. MUXMODE [9]	I/O VOLTAGE VALUE [10]	POWER [11]	HYS [12]	BUFFER TYPE [13]	PULL UP/DOWN TYPE [14]	DSIS [15]
Y25	ddr1_ecc_d4	ddr1_ecc_d4	No	0	IO	PD	PD		1.35/1.5/1.8	vdds_ddr1	No	LVC MOS DDR	Pux/PDy	
V24	ddr1_ecc_d5	ddr1_ecc_d5	No	0	IO	PD	PD		1.35/1.5/1.8	vdds_ddr1	No	LVC MOS DDR	Pux/PDy	
V25	ddr1_ecc_d6	ddr1_ecc_d6	No	0	IO	PD	PD		1.35/1.5/1.8	vdds_ddr1	No	LVC MOS DDR	Pux/PDy	
Y26	ddr1_ecc_d7	ddr1_ecc_d7	No	0	IO	PD	PD		1.35/1.5/1.8	vdds_ddr1	No	LVC MOS DDR	Pux/PDy	
AH24	ddr1_nck	ddr1_nck		0	O	PD	drive clk (OFF)		1.35/1.5/1.8	vdds_ddr1	No	LVC MOS DDR	Pux/PDy	
AE20	ddr1_odt0	ddr1_odt0		0	O	PD	drive 0 (OFF)		1.35/1.5/1.8	vdds_ddr1	No	LVC MOS DDR	Pux/PDy	
AF20	ddr1_rasn	ddr1_rasn		0	O	PD	drive 1 (OFF)		1.35/1.5/1.8	vdds_ddr1	No	LVC MOS DDR	Pux/PDy	
AG21	ddr1_rst	ddr1_rst		0	O	PD	drive 0 (OFF)		1.35/1.5/1.8	vdds_ddr1	No	LVC MOS DDR	Pux/PDy	
Y18	ddr1_vref0	ddr1_vref0		0	PWR	OFF	OFF		1.35/1.5/1.8	vdds_ddr1	No	LVC MOS DDR		
AH21	ddr1_wen	ddr1_wen		0	O	PD	drive 1 (OFF)		1.35/1.5/1.8	vdds_ddr1	No	LVC MOS DDR	Pux/PDy	
R25	ddr2_a0	ddr2_a0		0	O	PD	drive 1 (OFF)		1.35/1.5/1.8	vdds_ddr2	No	LVC MOS DDR	Pux/PDy	
R26	ddr2_a1	ddr2_a1		0	O	PD	drive 1 (OFF)		1.35/1.5/1.8	vdds_ddr2	No	LVC MOS DDR	Pux/PDy	
N23	ddr2_a10	ddr2_a10		0	O	PD	drive 1 (OFF)		1.35/1.5/1.8	vdds_ddr2	No	LVC MOS DDR	Pux/PDy	
P26	ddr2_a11	ddr2_a11		0	O	PD	drive 1 (OFF)		1.35/1.5/1.8	vdds_ddr2	No	LVC MOS DDR	Pux/PDy	
N28	ddr2_a12	ddr2_a12		0	O	PD	drive 1 (OFF)		1.35/1.5/1.8	vdds_ddr2	No	LVC MOS DDR	Pux/PDy	
T22	ddr2_a13	ddr2_a13		0	O	PD	drive 1 (OFF)		1.35/1.5/1.8	vdds_ddr2	No	LVC MOS DDR	Pux/PDy	
R22	ddr2_a14	ddr2_a14		0	O	PD	drive 1 (OFF)		1.35/1.5/1.8	vdds_ddr2	No	LVC MOS DDR	Pux/PDy	
U22	ddr2_a15	ddr2_a15		0	O	PD	drive 1 (OFF)		1.35/1.5/1.8	vdds_ddr2	No	LVC MOS DDR	Pux/PDy	
R28	ddr2_a2	ddr2_a2		0	O	PD	drive 1 (OFF)		1.35/1.5/1.8	vdds_ddr2	No	LVC MOS DDR	Pux/PDy	
R27	ddr2_a3	ddr2_a3		0	O	PD	drive 1 (OFF)		1.35/1.5/1.8	vdds_ddr2	No	LVC MOS DDR	Pux/PDy	
P23	ddr2_a4	ddr2_a4		0	O	PD	drive 1 (OFF)		1.35/1.5/1.8	vdds_ddr2	No	LVC MOS DDR	Pux/PDy	
P22	ddr2_a5	ddr2_a5		0	O	PD	drive 1 (OFF)		1.35/1.5/1.8	vdds_ddr2	No	LVC MOS DDR	Pux/PDy	
P25	ddr2_a6	ddr2_a6		0	O	PD	drive 1 (OFF)		1.35/1.5/1.8	vdds_ddr2	No	LVC MOS DDR	Pux/PDy	

表 4-2. Ball Characteristics⁽¹⁾ (continued)

BALL NUMBER [1]	BALL NAME [2]	SIGNAL NAME [3]	74x [4]	MUXMODE [5]	TYPE [6]	BALL RESET STATE [7]	BALL RESET REL. STATE [8]	BALL RESET REL. MUXMODE [9]	I/O VOLTAGE VALUE [10]	POWER [11]	HYS [12]	BUFFER TYPE [13]	PULL UP/DOWN TYPE [14]	DSIS [15]
N20	ddr2_a7	ddr2_a7		0	O	PD	drive 1 (OFF)		1.35/1.5/1.8	vdds_ddr2	No	LVC MOS DDR	Pux/PDy	
P27	ddr2_a8	ddr2_a8		0	O	PD	drive 1 (OFF)		1.35/1.5/1.8	vdds_ddr2	No	LVC MOS DDR	Pux/PDy	
N27	ddr2_a9	ddr2_a9		0	O	PD	drive 1 (OFF)		1.35/1.5/1.8	vdds_ddr2	No	LVC MOS DDR	Pux/PDy	
U23	ddr2_ba0	ddr2_ba0		0	O	PD	drive 1 (OFF)		1.35/1.5/1.8	vdds_ddr2	No	LVC MOS DDR	Pux/PDy	
U27	ddr2_ba1	ddr2_ba1		0	O	PD	drive 1 (OFF)		1.35/1.5/1.8	vdds_ddr2	No	LVC MOS DDR	Pux/PDy	
U26	ddr2_ba2	ddr2_ba2		0	O	PD	drive 1 (OFF)		1.35/1.5/1.8	vdds_ddr2	No	LVC MOS DDR	Pux/PDy	
U28	ddr2_casn	ddr2_casn		0	O	PD	drive 1 (OFF)		1.35/1.5/1.8	vdds_ddr2	No	LVC MOS DDR	Pux/PDy	
T28	ddr2_ck	ddr2_ck		0	O	PD	drive clk (OFF)		1.35/1.5/1.8	vdds_ddr2	No	LVC MOS DDR	Pux/PDy	
U24	ddr2_cke	ddr2_cke		0	O	PD	drive 0 (OFF)		1.35/1.5/1.8	vdds_ddr2	No	LVC MOS DDR	Pux/PDy	
P24	ddr2_csn0	ddr2_csn0		0	O	PD	drive 1 (OFF)		1.35/1.5/1.8	vdds_ddr2	No	LVC MOS DDR	Pux/PDy	
E26	ddr2_d0	ddr2_d0		0	IO	PU	PU		1.35/1.5/1.8	vdds_ddr2	No	LVC MOS DDR	Pux/PDy	
G25	ddr2_d1	ddr2_d1		0	IO	PU	PU		1.35/1.5/1.8	vdds_ddr2	No	LVC MOS DDR	Pux/PDy	
H24	ddr2_d10	ddr2_d10		0	IO	PU	PU		1.35/1.5/1.8	vdds_ddr2	No	LVC MOS DDR	Pux/PDy	
H26	ddr2_d11	ddr2_d11		0	IO	PU	PU		1.35/1.5/1.8	vdds_ddr2	No	LVC MOS DDR	Pux/PDy	
G26	ddr2_d12	ddr2_d12		0	IO	PU	PU		1.35/1.5/1.8	vdds_ddr2	No	LVC MOS DDR	Pux/PDy	
J25	ddr2_d13	ddr2_d13		0	IO	PU	PU		1.35/1.5/1.8	vdds_ddr2	No	LVC MOS DDR	Pux/PDy	
J26	ddr2_d14	ddr2_d14		0	IO	PU	PU		1.35/1.5/1.8	vdds_ddr2	No	LVC MOS DDR	Pux/PDy	
J24	ddr2_d15	ddr2_d15		0	IO	PU	PU		1.35/1.5/1.8	vdds_ddr2	No	LVC MOS DDR	Pux/PDy	
L22	ddr2_d16	ddr2_d16		0	IO	PU	PU		1.35/1.5/1.8	vdds_ddr2	No	LVC MOS DDR	Pux/PDy	
K20	ddr2_d17	ddr2_d17		0	IO	PU	PU		1.35/1.5/1.8	vdds_ddr2	No	LVC MOS DDR	Pux/PDy	
K21	ddr2_d18	ddr2_d18		0	IO	PU	PU		1.35/1.5/1.8	vdds_ddr2	No	LVC MOS DDR	Pux/PDy	
L23	ddr2_d19	ddr2_d19		0	IO	PU	PU		1.35/1.5/1.8	vdds_ddr2	No	LVC MOS DDR	Pux/PDy	
F25	ddr2_d2	ddr2_d2		0	IO	PU	PU		1.35/1.5/1.8	vdds_ddr2	No	LVC MOS DDR	Pux/PDy	

表 4-2. Ball Characteristics⁽¹⁾ (continued)

BALL NUMBER [1]	BALL NAME [2]	SIGNAL NAME [3]	74x [4]	MUXMODE [5]	TYPE [6]	BALL RESET STATE [7]	BALL RESET REL. STATE [8]	BALL RESET REL. MUXMODE [9]	I/O VOLTAGE VALUE [10]	POWER [11]	HYS [12]	BUFFER TYPE [13]	PULL UP/DOWN TYPE [14]	DSIS [15]
L24	ddr2_d20	ddr2_d20		0	IO	PU	PU		1.35/1.5/1.8	vdds_ddr2	No	LVC MOS DDR	Pux/PDy	
J23	ddr2_d21	ddr2_d21		0	IO	PU	PU		1.35/1.5/1.8	vdds_ddr2	No	LVC MOS DDR	Pux/PDy	
K22	ddr2_d22	ddr2_d22		0	IO	PU	PU		1.35/1.5/1.8	vdds_ddr2	No	LVC MOS DDR	Pux/PDy	
J20	ddr2_d23	ddr2_d23		0	IO	PU	PU		1.35/1.5/1.8	vdds_ddr2	No	LVC MOS DDR	Pux/PDy	
L27	ddr2_d24	ddr2_d24		0	IO	PU	PU		1.35/1.5/1.8	vdds_ddr2	No	LVC MOS DDR	Pux/PDy	
L26	ddr2_d25	ddr2_d25		0	IO	PU	PU		1.35/1.5/1.8	vdds_ddr2	No	LVC MOS DDR	Pux/PDy	
L25	ddr2_d26	ddr2_d26		0	IO	PU	PU		1.35/1.5/1.8	vdds_ddr2	No	LVC MOS DDR	Pux/PDy	
L28	ddr2_d27	ddr2_d27		0	IO	PU	PU		1.35/1.5/1.8	vdds_ddr2	No	LVC MOS DDR	Pux/PDy	
M23	ddr2_d28	ddr2_d28		0	IO	PU	PU		1.35/1.5/1.8	vdds_ddr2	No	LVC MOS DDR	Pux/PDy	
M24	ddr2_d29	ddr2_d29		0	IO	PU	PU		1.35/1.5/1.8	vdds_ddr2	No	LVC MOS DDR	Pux/PDy	
F24	ddr2_d3	ddr2_d3		0	IO	PU	PU		1.35/1.5/1.8	vdds_ddr2	No	LVC MOS DDR	Pux/PDy	
M25	ddr2_d30	ddr2_d30		0	IO	PU	PU		1.35/1.5/1.8	vdds_ddr2	No	LVC MOS DDR	Pux/PDy	
M26	ddr2_d31	ddr2_d31		0	IO	PU	PU		1.35/1.5/1.8	vdds_ddr2	No	LVC MOS DDR	Pux/PDy	
F26	ddr2_d4	ddr2_d4		0	IO	PU	PU		1.35/1.5/1.8	vdds_ddr2	No	LVC MOS DDR	Pux/PDy	
F27	ddr2_d5	ddr2_d5		0	IO	PU	PU		1.35/1.5/1.8	vdds_ddr2	No	LVC MOS DDR	Pux/PDy	
E27	ddr2_d6	ddr2_d6		0	IO	PU	PU		1.35/1.5/1.8	vdds_ddr2	No	LVC MOS DDR	Pux/PDy	
E28	ddr2_d7	ddr2_d7		0	IO	PU	PU		1.35/1.5/1.8	vdds_ddr2	No	LVC MOS DDR	Pux/PDy	
H23	ddr2_d8	ddr2_d8		0	IO	PU	PU		1.35/1.5/1.8	vdds_ddr2	No	LVC MOS DDR	Pux/PDy	
H25	ddr2_d9	ddr2_d9		0	IO	PU	PU		1.35/1.5/1.8	vdds_ddr2	No	LVC MOS DDR	Pux/PDy	
F28	ddr2_dqm0	ddr2_dqm0		0	O	PU	PU		1.35/1.5/1.8	vdds_ddr2	No	LVC MOS DDR	Pux/PDy	
G24	ddr2_dqm1	ddr2_dqm1		0	O	PU	PU		1.35/1.5/1.8	vdds_ddr2	No	LVC MOS DDR	Pux/PDy	
K23	ddr2_dqm2	ddr2_dqm2		0	O	PU	PU		1.35/1.5/1.8	vdds_ddr2	No	LVC MOS DDR	Pux/PDy	
M22	ddr2_dqm3	ddr2_dqm3		0	O	PU	PU		1.35/1.5/1.8	vdds_ddr2	No	LVC MOS DDR	Pux/PDy	

表 4-2. Ball Characteristics⁽¹⁾ (continued)

BALL NUMBER [1]	BALL NAME [2]	SIGNAL NAME [3]	74x [4]	MUXMODE [5]	TYPE [6]	BALL RESET STATE [7]	BALL RESET REL. STATE [8]	BALL RESET REL. MUXMODE [9]	I/O VOLTAGE VALUE [10]	POWER [11]	HYS [12]	BUFFER TYPE [13]	PULL UP/DOWN TYPE [14]	DSIS [15]
G28	ddr2_dqs0	ddr2_dqs0		0	IO	PD	PD		1.35/1.5/1.8	vdds_ddr2		LVC MOS DDR	Pux/PDy	
H27	ddr2_dqs1	ddr2_dqs1		0	IO	PD	PD		1.35/1.5/1.8	vdds_ddr2		LVC MOS DDR	Pux/PDy	
K27	ddr2_dqs2	ddr2_dqs2		0	IO	PD	PD		1.35/1.5/1.8	vdds_ddr2		LVC MOS DDR	Pux/PDy	
M28	ddr2_dqs3	ddr2_dqs3		0	IO	PD	PD		1.35/1.5/1.8	vdds_ddr2		LVC MOS DDR	Pux/PDy	
G27	ddr2_dqsn0	ddr2_dqsn0		0	IO	PU	PU		1.35/1.5/1.8	vdds_ddr2		LVC MOS DDR	Pux/PDy	
H28	ddr2_dqsn1	ddr2_dqsn1		0	IO	PU	PU		1.35/1.5/1.8	vdds_ddr2		LVC MOS DDR	Pux/PDy	
K28	ddr2_dqsn2	ddr2_dqsn2		0	IO	PU	PU		1.35/1.5/1.8	vdds_ddr2		LVC MOS DDR	Pux/PDy	
M27	ddr2_dqsn3	ddr2_dqsn3		0	IO	PU	PU		1.35/1.5/1.8	vdds_ddr2		LVC MOS DDR	Pux/PDy	
T27	ddr2_nck	ddr2_nck		0	O	PD	drive clk (OFF)		1.35/1.5/1.8	vdds_ddr2	No	LVC MOS DDR	Pux/PDy	
R23	ddr2_odt0	ddr2_odt0		0	O	PD	drive 0 (OFF)		1.35/1.5/1.8	vdds_ddr2	No	LVC MOS DDR	Pux/PDy	
T23	ddr2_rasn	ddr2_rasn		0	O	PD	drive 1 (OFF)		1.35/1.5/1.8	vdds_ddr2	No	LVC MOS DDR	Pux/PDy	
R24	ddr2_rst	ddr2_rst		0	O	PD	drive 0 (OFF)		1.35/1.5/1.8	vdds_ddr2	No	LVC MOS DDR	Pux/PDy	
N22	ddr2_vref0	ddr2_vref0		0	PWR	OFF	OFF		1.35/1.5/1.8	vdds_ddr2	No	LVC MOS DDR		
U25	ddr2_wen	ddr2_wen		0	O	PD	drive 1 (OFF)		1.35/1.5/1.8	vdds_ddr2	No	LVC MOS DDR	Pux/PDy	
G21	emu0	emu0		0	IO	PU	PU	0	1.8/3.3	vddshv3	Yes	Dual Voltage LVC MOS	PU/PD	
		gpio8_30		14	IO									
D24	emu1	emu1		0	IO	PU	PU	0	1.8/3.3	vddshv3	Yes	Dual Voltage LVC MOS	PU/PD	
		gpio8_31		14	IO									
AC5	gpio6_10	gpio6_10		0	IO	PU	PU	15	1.8/3.3	vddshv7	Yes	Dual Voltage LVC MOS	PU/PD	
		mdio_mclk		1	O									
		i2c3_sda		2	IO									
		usb3_ulpi_d7		3	IO									
		vin2b_hsync1		4	I									
		vin5a_clk0	No	9	I									
		ehrpwm2A		10	O									
		gpio6_10		14	IO									
Driver off		15	I											

表 4-2. Ball Characteristics⁽¹⁾ (continued)

BALL NUMBER [1]	BALL NAME [2]	SIGNAL NAME [3]	74x [4]	MUXMODE [5]	TYPE [6]	BALL RESET STATE [7]	BALL RESET REL. STATE [8]	BALL RESET REL. MUXMODE [9]	I/O VOLTAGE VALUE [10]	POWER [11]	HYS [12]	BUFFER TYPE [13]	PULL UP/DOWN TYPE [14]	DSIS [15]
AB4	gpio6_11	gpio6_11		0	IO	PU	PU	15	1.8/3.3	vddshv7	Yes	Dual Voltage LVCMOS	PU/PD	
		mdio_d		1	IO									1
		i2c3_scl		2	IO									1
		usb3_ulpi_d6		3	IO									0
		vin2b_vsync1		4	I									
		vin5a_de0	No	9	I									0
		ehrpwm2B		10	O									
		Driver off		15	I									
E21	gpio6_14	gpio6_14		0	IO	PU	PU	15	1.8/3.3	vddshv3	Yes	Dual Voltage LVCMOS	PU/PD	
		mcasp1_axr8		1	IO									0
		dcan2_tx		2	IO									1
		uart10_rxd		3	I									1
		vout2_hsync		6	O									
		vin4a_hsync0		8	I									0
		i2c3_sda		9	IO									1
		timer1		10	IO									
		gpio6_14		14	IO									
		Driver off		15	I									
F20	gpio6_15	gpio6_15		0	IO	PU	PU	15	1.8/3.3	vddshv3	Yes	Dual Voltage LVCMOS	PU/PD	
		mcasp1_axr9		1	IO									0
		dcan2_rx		2	IO									1
		uart10_txd		3	O									
		vout2_vsync		6	O									
		vin4a_vsync0		8	I									0
		i2c3_scl		9	IO									1
		timer2		10	IO									
		gpio6_15		14	IO									
		Driver off		15	I									
F21	gpio6_16	gpio6_16		0	IO	PU	PU	15	1.8/3.3	vddshv3	Yes	Dual Voltage LVCMOS	PU/PD	
		mcasp1_axr10		1	IO									0
		vout2_fld		6	O									
		vin4a_fld0		8	I									0
		clkout1		9	O									
		timer3		10	IO									
		gpio6_16		14	IO									
		Driver off		15	I									

表 4-2. Ball Characteristics⁽¹⁾ (continued)

BALL NUMBER [1]	BALL NAME [2]	SIGNAL NAME [3]	74x [4]	MUXMODE [5]	TYPE [6]	BALL RESET STATE [7]	BALL RESET REL. STATE [8]	BALL RESET REL. MUXMODE [9]	I/O VOLTAGE VALUE [10]	POWER [11]	HYS [12]	BUFFER TYPE [13]	PULL UP/DOWN TYPE [14]	DSIS [15]
R6	gpmc_a0	gpmc_a0		0	O	PD	PD	15	1.8/3.3	vddshv10	Yes	Dual Voltage LVCMOS	PU/PD	
		vin3a_d16		2	I									0
		vout3_d16		3	O									
		vin4a_d0		4	I									0
		vin4b_d0		6	I									0
		i2c4_scl		7	IO									1
		uart5_rxd		8	I									1
		gpio7_3		14	IO									
Driver off		15	I											
T9	gpmc_a1	gpmc_a1		0	O	PD	PD	15	1.8/3.3	vddshv10	Yes	Dual Voltage LVCMOS	PU/PD	
		vin3a_d17		2	I									0
		vout3_d17		3	O									
		vin4a_d1		4	I									0
		vin4b_d1		6	I									0
		i2c4_sda		7	IO									1
		uart5_txd		8	O									
		gpio7_4		14	IO									
Driver off		15	I											
N9	gpmc_a10	gpmc_a10		0	O	PD	PD	15	1.8/3.3	vddshv10	Yes	Dual Voltage LVCMOS	PU/PD	
		vin3a_de0		2	I									0
		vout3_de		3	O									
		vin4b_clk1		6	I									0
		timer10		7	IO									
		spi4_d0		8	IO									0
		gpio2_0		14	IO									
		Driver off		15	I									
P9	gpmc_a11	gpmc_a11		0	O	PD	PD	15	1.8/3.3	vddshv10	Yes	Dual Voltage LVCMOS	PU/PD	
		vin3a_fld0		2	I									0
		vout3_fld		3	O									
		vin4a_fld0		4	I									0
		vin4b_de1		6	I									0
		timer9		7	IO									
		spi4_cs0		8	IO									1
		gpio2_1		14	IO									
Driver off		15	I											

表 4-2. Ball Characteristics⁽¹⁾ (continued)

BALL NUMBER [1]	BALL NAME [2]	SIGNAL NAME [3]	74x [4]	MUXMODE [5]	TYPE [6]	BALL RESET STATE [7]	BALL RESET REL. STATE [8]	BALL RESET REL. MUXMODE [9]	I/O VOLTAGE VALUE [10]	POWER [11]	HYS [12]	BUFFER TYPE [13]	PULL UP/DOWN TYPE [14]	DSIS [15]
P4	gpmc_a12	gpmc_a12		0	O	PD	PD	15	1.8/3.3	vddshv10	Yes	Dual Voltage LVCMOS	PU/PD	
		vin4a_clk0		4	I									0
		gpmc_a0		5	O									
		vin4b_fld1		6	I									0
		timer8		7	IO									
		spi4_cs1		8	IO									1
		dma_evt1		9	I									0
		gpio2_2		14	IO									
Driver off		15	I											
R3	gpmc_a13	gpmc_a13		0	O	PD	PD	15	1.8/3.3	vddshv10	Yes	Dual Voltage LVCMOS	PU/PD	
		qspi1_rclk		1	I									0
		vin4a_hsync0		4	I									0
		timer7		7	IO									
		spi4_cs2		8	IO									1
		dma_evt2		9	I									0
		gpio2_3		14	IO									
		Driver off		15	I									
T2	gpmc_a14	gpmc_a14		0	O	PD	PD	15	1.8/3.3	vddshv10	Yes	Dual Voltage LVCMOS	PU/PD	
		qspi1_d3		1	I									0
		vin4a_vsync0		4	I									0
		timer6		7	IO									
		spi4_cs3		8	IO									1
		gpio2_4		14	IO									
		Driver off		15	I									
		U2	gpmc_a15	gpmc_a15										0
qspi1_d2				1	I	0								
vin4a_d8				4	I	0								
timer5				7	IO									
gpio2_5				14	IO									
Driver off				15	I									
U1	gpmc_a16	gpmc_a16		0	O	PD	PD	15	1.8/3.3	vddshv10	Yes	Dual Voltage LVCMOS	PU/PD	
		qspi1_d0		1	IO									0
		vin4a_d9		4	I									0
		gpio2_6		14	IO									
		Driver off		15	I									

表 4-2. Ball Characteristics⁽¹⁾ (continued)

BALL NUMBER [1]	BALL NAME [2]	SIGNAL NAME [3]	74x [4]	MUXMODE [5]	TYPE [6]	BALL RESET STATE [7]	BALL RESET REL. STATE [8]	BALL RESET REL. MUXMODE [9]	I/O VOLTAGE VALUE [10]	POWER [11]	HYS [12]	BUFFER TYPE [13]	PULL UP/DOWN TYPE [14]	DSIS [15]
P3	gpmc_a17	gpmc_a17		0	O	PD	PD	15	1.8/3.3	vddshv10	Yes	Dual Voltage LVCMOS	PU/PD	
		qspi1_d1		1	I									0
		vin4a_d10		4	I									0
		gpio2_7		14	IO									
		Driver off		15	I									
R2	gpmc_a18	gpmc_a18		0	O	PD	PD	15	1.8/3.3	vddshv10	Yes	Dual Voltage LVCMOS	PU/PD	
		qspi1_sclk		1	O									
		vin4a_d11		4	I									0
		gpio2_8		14	IO									
		Driver off		15	I									
K7 ⁽¹⁰⁾	gpmc_a19	gpmc_a19		0	O	PD	PD	15	1.8/3.3	vddshv11	Yes	Dual Voltage LVCMOS	PU/PD	
		mmc2_dat4		1	IO									1
		gpmc_a13		2	O									
		vin4a_d12		4	I									0
		vin3b_d0		6	I									0
		gpio2_9		14	IO									
		Driver off		15	I									
T6	gpmc_a2	gpmc_a2		0	O	PD	PD	15	1.8/3.3	vddshv10	Yes	Dual Voltage LVCMOS	PU/PD	
		vin3a_d18		2	I									0
		vout3_d18		3	O									
		vin4a_d2		4	I									0
		vin4b_d2		6	I									0
		uart7_rxd		7	I									1
		uart5_ctsn		8	I									1
		gpio7_5		14	IO									
		Driver off		15	I									
M7 ⁽¹⁰⁾	gpmc_a20	gpmc_a20		0	O	PD	PD	15	1.8/3.3	vddshv11	Yes	Dual Voltage LVCMOS	PU/PD	
		mmc2_dat5		1	IO									1
		gpmc_a14		2	O									
		vin4a_d13		4	I									0
		vin3b_d1		6	I									0
		gpio2_10		14	IO									
		Driver off		15	I									

表 4-2. Ball Characteristics⁽¹⁾ (continued)

BALL NUMBER [1]	BALL NAME [2]	SIGNAL NAME [3]	74x [4]	MUXMODE [5]	TYPE [6]	BALL RESET STATE [7]	BALL RESET REL. STATE [8]	BALL RESET REL. MUXMODE [9]	I/O VOLTAGE VALUE [10]	POWER [11]	HYS [12]	BUFFER TYPE [13]	PULL UP/DOWN TYPE [14]	DSIS [15]
J5 ⁽¹⁰⁾	gpmc_a21	gpmc_a21		0	O	PD	PD	15	1.8/3.3	vddshv11	Yes	Dual Voltage LVCMOS	PU/PD	
		mmc2_dat6		1	IO									1
		gpmc_a15		2	O									
		vin4a_d14		4	I									0
		vin3b_d2		6	I									0
		gpio2_11		14	IO									
		Driver off		15	I									
K6 ⁽¹⁰⁾	gpmc_a22	gpmc_a22		0	O	PD	PD	15	1.8/3.3	vddshv11	Yes	Dual Voltage LVCMOS	PU/PD	
		mmc2_dat7		1	IO									1
		gpmc_a16		2	O									
		vin4a_d15		4	I									0
		vin3b_d3		6	I									0
		gpio2_12		14	IO									
		Driver off		15	I									
J7	gpmc_a23	gpmc_a23		0	O	PD	PD	15	1.8/3.3	vddshv11	Yes	Dual Voltage LVCMOS	PU/PD	
		mmc2_clk		1	IO									1
		gpmc_a17		2	O									
		vin4a_fld0		4	I									0
		vin3b_d4		6	I									0
		gpio2_13		14	IO									
		Driver off		15	I									
J4 ⁽¹⁰⁾	gpmc_a24	gpmc_a24		0	O	PD	PD	15	1.8/3.3	vddshv11	Yes	Dual Voltage LVCMOS	PU/PD	
		mmc2_dat0		1	IO									1
		gpmc_a18		2	O									
		vin3b_d5		6	I									0
		gpio2_14		14	IO									
		Driver off		15	I									
J6 ⁽¹⁰⁾	gpmc_a25	gpmc_a25		0	O	PD	PD	15	1.8/3.3	vddshv11	Yes	Dual Voltage LVCMOS	PU/PD	
		mmc2_dat1		1	IO									1
		gpmc_a19		2	O									
		vin3b_d6		6	I									0
		gpio2_15		14	IO									
		Driver off		15	I									

表 4-2. Ball Characteristics⁽¹⁾ (continued)

BALL NUMBER [1]	BALL NAME [2]	SIGNAL NAME [3]	74x [4]	MUXMODE [5]	TYPE [6]	BALL RESET STATE [7]	BALL RESET REL. STATE [8]	BALL RESET REL. MUXMODE [9]	I/O VOLTAGE VALUE [10]	POWER [11]	HYS [12]	BUFFER TYPE [13]	PULL UP/DOWN TYPE [14]	DSIS [15]
H4 ⁽¹⁰⁾	gpmc_a26	gpmc_a26		0	O	PD	PD	15	1.8/3.3	vddshv11	Yes	Dual Voltage LVCMOS	PU/PD	
		mmc2_dat2		1	IO									1
		gpmc_a20		2	O									
		vin3b_d7		6	I									0
		gpio2_16		14	IO									
		Driver off		15	I									
H5 ⁽¹⁰⁾	gpmc_a27	gpmc_a27		0	O	PD	PD	15	1.8/3.3	vddshv11	Yes	Dual Voltage LVCMOS	PU/PD	
		mmc2_dat3		1	IO									1
		gpmc_a21		2	O									
		vin3b_hsync1		6	I									0
		gpio2_17		14	IO									
		Driver off		15	I									
T7	gpmc_a3	gpmc_a3		0	O	PD	PD	15	1.8/3.3	vddshv10	Yes	Dual Voltage LVCMOS	PU/PD	
		qspi1_cs2		1	O									1
		vin3a_d19		2	I									0
		vout3_d19		3	O									
		vin4a_d3		4	I									0
		vin4b_d3		6	I									0
		uart7_txd		7	O									
		uart5_rtsn		8	O									
		gpio7_6		14	IO									
		Driver off		15	I									
		P6	gpmc_a4	gpmc_a4		0	O	PD	PD	15	1.8/3.3			vddshv10
qspi1_cs3				1	O							1		
vin3a_d20				2	I							0		
vout3_d20				3	O									
vin4a_d4				4	I							0		
vin4b_d4				6	I							0		
i2c5_scl				7	IO							1		
uart6_rxd				8	I							1		
gpio1_26				14	IO									
Driver off				15	I									

表 4-2. Ball Characteristics⁽¹⁾ (continued)

BALL NUMBER [1]	BALL NAME [2]	SIGNAL NAME [3]	74x [4]	MUXMODE [5]	TYPE [6]	BALL RESET STATE [7]	BALL RESET REL. STATE [8]	BALL RESET REL. MUXMODE [9]	I/O VOLTAGE VALUE [10]	POWER [11]	HYS [12]	BUFFER TYPE [13]	PULL UP/DOWN TYPE [14]	DSIS [15]
R9	gpmc_a5	gpmc_a5		0	O	PD	PD	15	1.8/3.3	vddshv10	Yes	Dual Voltage LVCMOS	PU/PD	
		vin3a_d21		2	I									0
		vout3_d21		3	O									
		vin4a_d5		4	I									0
		vin4b_d5		6	I									0
		i2c5_sda		7	IO									1
		uart6_txd		8	O									
		gpio1_27		14	IO									
Driver off		15	I											
R5	gpmc_a6	gpmc_a6		0	O	PD	PD	15	1.8/3.3	vddshv10	Yes	Dual Voltage LVCMOS	PU/PD	
		vin3a_d22		2	I									0
		vout3_d22		3	O									
		vin4a_d6		4	I									0
		vin4b_d6		6	I									0
		uart8_rxd		7	I									1
		uart6_ctsn		8	I									1
		gpio1_28		14	IO									
Driver off		15	I											
P5	gpmc_a7	gpmc_a7		0	O	PD	PD	15	1.8/3.3	vddshv10	Yes	Dual Voltage LVCMOS	PU/PD	
		vin3a_d23		2	I									0
		vout3_d23		3	O									
		vin4a_d7		4	I									0
		vin4b_d7		6	I									0
		uart8_txd		7	O									
		uart6_rtsn		8	O									
		gpio1_29		14	IO									
Driver off		15	I											
N7	gpmc_a8	gpmc_a8		0	O	PD	PD	15	1.8/3.3	vddshv10	Yes	Dual Voltage LVCMOS	PU/PD	
		vin3a_hsync0		2	I									0
		vout3_hsync		3	O									
		vin4b_hsync1		6	I									0
		timer12		7	IO									
		spi4_sclk		8	IO									0
		gpio1_30		14	IO									
		Driver off		15	I									

表 4-2. Ball Characteristics⁽¹⁾ (continued)

BALL NUMBER [1]	BALL NAME [2]	SIGNAL NAME [3]	74x [4]	MUXMODE [5]	TYPE [6]	BALL RESET STATE [7]	BALL RESET REL. STATE [8]	BALL RESET REL. MUXMODE [9]	I/O VOLTAGE VALUE [10]	POWER [11]	HYS [12]	BUFFER TYPE [13]	PULL UP/DOWN TYPE [14]	DSIS [15]
R4	gpmc_a9	gpmc_a9		0	O	PD	PD	15	1.8/3.3	vddshv10	Yes	Dual Voltage LVCMOS	PU/PD	
		vin3a_vsync0		2	I									0
		vout3_vsync		3	O									
		vin4b_vsync1		6	I									0
		timer11		7	IO									
		spi4_d1		8	IO									0
		gpio1_31		14	IO									
Driver off		15	I											
M6	gpmc_ad0	gpmc_ad0		0	IO	OFF	OFF	15	1.8/3.3	vddshv10	Yes	Dual Voltage LVCMOS	PU/PD	0
		vin3a_d0		2	I									0
		vout3_d0		3	O									
		gpio1_6		14	IO									
		sysboot0		15	I									
M2	gpmc_ad1	gpmc_ad1		0	IO	OFF	OFF	15	1.8/3.3	vddshv10	Yes	Dual Voltage LVCMOS	PU/PD	0
		vin3a_d1		2	I									0
		vout3_d1		3	O									
		gpio1_7		14	IO									
		sysboot1		15	I									
J1	gpmc_ad10	gpmc_ad10		0	IO	OFF	OFF	15	1.8/3.3	vddshv10	Yes	Dual Voltage LVCMOS	PU/PD	0
		vin3a_d10		2	I									0
		vout3_d10		3	O									
		gpio7_28		14	IO									
		sysboot10		15	I									
J2	gpmc_ad11	gpmc_ad11		0	IO	OFF	OFF	15	1.8/3.3	vddshv10	Yes	Dual Voltage LVCMOS	PU/PD	0
		vin3a_d11		2	I									0
		vout3_d11		3	O									
		gpio7_29		14	IO									
		sysboot11		15	I									
H1	gpmc_ad12	gpmc_ad12		0	IO	OFF	OFF	15	1.8/3.3	vddshv10	Yes	Dual Voltage LVCMOS	PU/PD	0
		vin3a_d12		2	I									0
		vout3_d12		3	O									
		gpio1_18		14	IO									
		sysboot12		15	I									

表 4-2. Ball Characteristics⁽¹⁾ (continued)

BALL NUMBER [1]	BALL NAME [2]	SIGNAL NAME [3]	74x [4]	MUXMODE [5]	TYPE [6]	BALL RESET STATE [7]	BALL RESET REL. STATE [8]	BALL RESET REL. MUXMODE [9]	I/O VOLTAGE VALUE [10]	POWER [11]	HYS [12]	BUFFER TYPE [13]	PULL UP/DOWN TYPE [14]	DSIS [15]
J3	gpmc_ad13	gpmc_ad13		0	IO	OFF	OFF	15	1.8/3.3	vddshv10	Yes	Dual Voltage LVCMOS	PU/PD	0
		vin3a_d13		2	I									0
		vout3_d13		3	O									
		gpio1_19		14	IO									
		sysboot13		15	I									
H2	gpmc_ad14	gpmc_ad14		0	IO	OFF	OFF	15	1.8/3.3	vddshv10	Yes	Dual Voltage LVCMOS	PU/PD	0
		vin3a_d14		2	I									0
		vout3_d14		3	O									
		gpio1_20		14	IO									
		sysboot14		15	I									
H3	gpmc_ad15	gpmc_ad15		0	IO	OFF	OFF	15	1.8/3.3	vddshv10	Yes	Dual Voltage LVCMOS	PU/PD	0
		vin3a_d15		2	I									0
		vout3_d15		3	O									
		gpio1_21		14	IO									
		sysboot15		15	I									
L5	gpmc_ad2	gpmc_ad2		0	IO	OFF	OFF	15	1.8/3.3	vddshv10	Yes	Dual Voltage LVCMOS	PU/PD	0
		vin3a_d2		2	I									0
		vout3_d2		3	O									
		gpio1_8		14	IO									
		sysboot2		15	I									
M1	gpmc_ad3	gpmc_ad3		0	IO	OFF	OFF	15	1.8/3.3	vddshv10	Yes	Dual Voltage LVCMOS	PU/PD	0
		vin3a_d3		2	I									0
		vout3_d3		3	O									
		gpio1_9		14	IO									
		sysboot3		15	I									
L6	gpmc_ad4	gpmc_ad4		0	IO	OFF	OFF	15	1.8/3.3	vddshv10	Yes	Dual Voltage LVCMOS	PU/PD	0
		vin3a_d4		2	I									0
		vout3_d4		3	O									
		gpio1_10		14	IO									
		sysboot4		15	I									
L4	gpmc_ad5	gpmc_ad5		0	IO	OFF	OFF	15	1.8/3.3	vddshv10	Yes	Dual Voltage LVCMOS	PU/PD	0
		vin3a_d5		2	I									0
		vout3_d5		3	O									
		gpio1_11		14	IO									
		sysboot5		15	I									

表 4-2. Ball Characteristics⁽¹⁾ (continued)

BALL NUMBER [1]	BALL NAME [2]	SIGNAL NAME [3]	74x [4]	MUXMODE [5]	TYPE [6]	BALL RESET STATE [7]	BALL RESET REL. STATE [8]	BALL RESET REL. MUXMODE [9]	I/O VOLTAGE VALUE [10]	POWER [11]	HYS [12]	BUFFER TYPE [13]	PULL UP/DOWN TYPE [14]	DSIS [15]
L3	gpmc_ad6	gpmc_ad6		0	IO	OFF	OFF	15	1.8/3.3	vddshv10	Yes	Dual Voltage LVCMOS	PU/PD	0
		vin3a_d6		2	I									0
		vout3_d6		3	O									
		gpio1_12		14	IO									
		sysboot6		15	I									
L2	gpmc_ad7	gpmc_ad7		0	IO	OFF	OFF	15	1.8/3.3	vddshv10	Yes	Dual Voltage LVCMOS	PU/PD	0
		vin3a_d7		2	I									0
		vout3_d7		3	O									
		gpio1_13		14	IO									
		sysboot7		15	I									
L1	gpmc_ad8	gpmc_ad8		0	IO	OFF	OFF	15	1.8/3.3	vddshv10	Yes	Dual Voltage LVCMOS	PU/PD	0
		vin3a_d8		2	I									0
		vout3_d8		3	O									
		gpio7_18		14	IO									
		sysboot8		15	I									
K2	gpmc_ad9	gpmc_ad9		0	IO	OFF	OFF	15	1.8/3.3	vddshv10	Yes	Dual Voltage LVCMOS	PU/PD	0
		vin3a_d9		2	I									0
		vout3_d9		3	O									
		gpio7_19		14	IO									
		sysboot9		15	I									
N1	gpmc_advn_ale	gpmc_advn_ale		0	O	PU	PU	15	1.8/3.3	vddshv10	Yes	Dual Voltage LVCMOS	PU/PD	
		gpmc_cs6		1	O									
		clkout2		2	O									
		gpmc_wait1		3	I									1
		vin4a_vsync0		4	I									0
		gpmc_a2		5	O									
		gpmc_a23		6	O									
		timer3		7	IO									
		i2c3_sda		8	IO									1
		dma_evt2		9	I									0
		gpio2_23		14	IO									
		Driver off		15	I									

表 4-2. Ball Characteristics⁽¹⁾ (continued)

BALL NUMBER [1]	BALL NAME [2]	SIGNAL NAME [3]	74x [4]	MUXMODE [5]	TYPE [6]	BALL RESET STATE [7]	BALL RESET REL. STATE [8]	BALL RESET REL. MUXMODE [9]	I/O VOLTAGE VALUE [10]	POWER [11]	HYS [12]	BUFFER TYPE [13]	PULL UP/DOWN TYPE [14]	DSIS [15]
N6	gpmc_ben0	gpmc_ben0		0	O	PU	PU	15	1.8/3.3	vddshv10	Yes	Dual Voltage LVCMOS	PU/PD	
		gpmc_cs4		1	O									
		vin1b_hsync1	No	3	I									0
		vin3b_de1		6	I									0
		timer2		7	IO									
		dma_evt3		9	I									0
		gpio2_26		14	IO									
		Driver off		15	I									
M4	gpmc_ben1	gpmc_ben1		0	O	PU	PU	15	1.8/3.3	vddshv10	Yes	Dual Voltage LVCMOS	PU/PD	
		gpmc_cs5		1	O									
		vin1b_de1	No	3	I									0
		vin3b_clk1		4	I									0
		gpmc_a3		5	O									
		vin3b_fld1		6	I									0
		timer1		7	IO									
		dma_evt4		9	I									0
		gpio2_27		14	IO									
		Driver off		15	I									
P7	gpmc_clk	gpmc_clk		0	IO	PU	PU	15	1.8/3.3	vddshv10	Yes	Dual Voltage LVCMOS	PU/PD	0
		gpmc_cs7		1	O									
		clkout1		2	O									
		gpmc_wait1		3	I									1
		vin4a_hsync0		4	I									0
		vin4a_de0		5	I									0
		vin3b_clk1		6	I									0
		timer4		7	IO									
		i2c3_scl		8	IO									1
		dma_evt1		9	I									0
		gpio2_22		14	IO									
		Driver off		15	I									
		T1	gpmc_cs0	gpmc_cs0										0
gpio2_19				14	IO									
Driver off				15	I									

表 4-2. Ball Characteristics⁽¹⁾ (continued)

BALL NUMBER [1]	BALL NAME [2]	SIGNAL NAME [3]	74x [4]	MUXMODE [5]	TYPE [6]	BALL RESET STATE [7]	BALL RESET REL. STATE [8]	BALL RESET REL. MUXMODE [9]	I/O VOLTAGE VALUE [10]	POWER [11]	HYS [12]	BUFFER TYPE [13]	PULL UP/DOWN TYPE [14]	DSIS [15]
H6	gpmc_cs1	gpmc_cs1		0	O	PU	PU	15	1.8/3.3	vddshv11	Yes	Dual Voltage LVCMOS	PU/PD	
		mmc2_cmd		1	IO									1
		gpmc_a22		2	O									
		vin4a_de0		4	I									0
		vin3b_vsync1		6	I									0
		gpio2_18		14	IO									
	Driver off		15	I										
P2	gpmc_cs2	gpmc_cs2		0	O	PU	PU	15	1.8/3.3	vddshv10	Yes	Dual Voltage LVCMOS	PU/PD	
		qspi1_cs0		1	O									1
		gpio2_20		14	IO									
		Driver off		15	I									
P1	gpmc_cs3	gpmc_cs3		0	O	PU	PU	15	1.8/3.3	vddshv10	Yes	Dual Voltage LVCMOS	PU/PD	
		qspi1_cs1		1	O									1
		vin3a_clk0		2	I									0
		vout3_clk		3	O									
		gpmc_a1		5	O									
		gpio2_21		14	IO									
		Driver off		15	I									
M5	gpmc_oen_ren	gpmc_oen_ren		0	O	PU	PU	15	1.8/3.3	vddshv10	Yes	Dual Voltage LVCMOS	PU/PD	
		gpio2_24		14	IO									
		Driver off		15	I									
N2	gpmc_wait0	gpmc_wait0		0	I	PU	PU	15	1.8/3.3	vddshv10	Yes	Dual Voltage LVCMOS	PU/PD	1
		gpio2_28		14	IO									
		Driver off		15	I									
M3	gpmc_wen	gpmc_wen		0	O	PU	PU	15	1.8/3.3	vddshv10	Yes	Dual Voltage LVCMOS	PU/PD	
		gpio2_25		14	IO									
		Driver off		15	I									
AG16	hdmi1_clockx	hdmi1_clockx		0	O				1.8	vdda_hdmi		HDMIPHY	PDy	
AH16	hdmi1_clocky	hdmi1_clocky		0	O				1.8	vdda_hdmi		HDMIPHY	PDy	
AG17	hdmi1_data0x	hdmi1_data0x		0	O				1.8	vdda_hdmi		HDMIPHY	PDy	
AH17	hdmi1_data0y	hdmi1_data0y		0	O				1.8	vdda_hdmi		HDMIPHY	PDy	
AG18	hdmi1_data1x	hdmi1_data1x		0	O				1.8	vdda_hdmi		HDMIPHY	PDy	
AH18	hdmi1_data1y	hdmi1_data1y		0	O				1.8	vdda_hdmi		HDMIPHY	PDy	
AG19	hdmi1_data2x	hdmi1_data2x		0	O				1.8	vdda_hdmi		HDMIPHY	PDy	
AH19	hdmi1_data2y	hdmi1_data2y		0	O				1.8	vdda_hdmi		HDMIPHY	PDy	

表 4-2. Ball Characteristics⁽¹⁾ (continued)

BALL NUMBER [1]	BALL NAME [2]	SIGNAL NAME [3]	74x [4]	MUXMODE [5]	TYPE [6]	BALL RESET STATE [7]	BALL RESET REL. STATE [8]	BALL RESET REL. MUXMODE [9]	I/O VOLTAGE VALUE [10]	POWER [11]	HYS [12]	BUFFER TYPE [13]	PULL UP/DOWN TYPE [14]	DSIS [15]
C20	i2c1_scl	i2c1_scl		0	IO	OFF	OFF		1.8/3.3	vddshv3	Yes	Dual Voltage LVCMOS I2C	PU/PD	
C21	i2c1_sda	i2c1_sda		0	IO	OFF	OFF		1.8/3.3	vddshv3	Yes	Dual Voltage LVCMOS I2C	PU/PD	
F17	i2c2_scl	i2c2_scl		0	IO	OFF	OFF	15	1.8/3.3	vddshv3	Yes	Dual Voltage LVCMOS I2C	PU/PD	1
		hdmi1_ddc_sda		1	IO									
		Driver off		15	I									
C25	i2c2_sda	i2c2_sda		0	IO	OFF	OFF	15	1.8/3.3	vddshv3	Yes	Dual Voltage LVCMOS I2C	PU/PD	1
		hdmi1_ddc_scl		1	IO									
		Driver off		15	I									
AH15	ljcb_clkn	ljcb_clkn		0	IO				1.8	vdda_pcie		LJCB		
AG15	ljcb_clkp	ljcb_clkp		0	IO				1.8	vdda_pcie		LJCB		
B14	mcasep1_aclkr	mcasep1_aclkr		0	IO	PD	PD	15	1.8/3.3	vddshv3	Yes	Dual Voltage LVCMOS	PU/PD	0
		mcasep7_axr2		1	IO									0
		vout2_d0		6	O									
		vin4a_d0		8	I									0
		i2c4_sda		10	IO									1
		gpio5_0		14	IO									
Driver off		15	I											
C14	mcasep1_aclkx	mcasep1_aclkx		0	IO	PD	PD	15	1.8/3.3	vddshv3	Yes	Dual Voltage LVCMOS	PU/PD	0
		vin6a_fld0	No	7	I									0
		i2c3_sda		10	IO									1
		gpio7_31		14	IO									
		Driver off		15	I									
G12	mcasep1_axr0	mcasep1_axr0		0	IO	PD	PD	15	1.8/3.3	vddshv3	Yes	Dual Voltage LVCMOS	PU/PD	0
		uart6_rxd		3	I									1
		vin6a_vsync0	No	7	I									0
		i2c5_sda		10	IO									1
		gpio5_2		14	IO									
		Driver off		15	I									

表 4-2. Ball Characteristics⁽¹⁾ (continued)

BALL NUMBER [1]	BALL NAME [2]	SIGNAL NAME [3]	74x [4]	MUXMODE [5]	TYPE [6]	BALL RESET STATE [7]	BALL RESET REL. STATE [8]	BALL RESET REL. MUXMODE [9]	I/O VOLTAGE VALUE [10]	POWER [11]	HYS [12]	BUFFER TYPE [13]	PULL UP/DOWN TYPE [14]	DSIS [15]		
F12	mcasep1_axr1	mcasep1_axr1		0	IO	PD	PD	15	1.8/3.3	vddshv3	Yes	Dual Voltage LVCMOS	PU/PD	0		
		uart6_txd		3	O											
		vin6a_hsync0	No	7	I										0	
		i2c5_scl		10	IO											1
		gpio5_3		14	IO											
		Driver off		15	I											
B13	mcasep1_axr10	mcasep1_axr10		0	IO	PD	PD	15	1.8/3.3	vddshv3	Yes	Dual Voltage LVCMOS	PU/PD	0		
		mcasep6_aclkx		1	IO											
		mcasep6_aclkr		2	IO											
		spi3_d0		3	IO											
		vin6a_d13	No	7	I											
		timer7		10	IO											
		gpio5_12		14	IO											
		Driver off		15	I											
A12	mcasep1_axr11	mcasep1_axr11		0	IO	PD	PD	15	1.8/3.3	vddshv3	Yes	Dual Voltage LVCMOS	PU/PD	0		
		mcasep6_fsx		1	IO											
		mcasep6_fsr		2	IO											
		spi3_cs0		3	IO											
		vin6a_d12	No	7	I											
		timer8		10	IO											
		gpio4_17		14	IO											
		Driver off		15	I											
E14	mcasep1_axr12	mcasep1_axr12		0	IO	PD	PD	15	1.8/3.3	vddshv3	Yes	Dual Voltage LVCMOS	PU/PD	0		
		mcasep7_axr0		1	IO											
		spi3_cs1		3	IO											
		vin6a_d11	No	7	I											
		timer9		10	IO											
		gpio4_18		14	IO											
		Driver off		15	I											
A13	mcasep1_axr13	mcasep1_axr13		0	IO	PD	PD	15	1.8/3.3	vddshv3	Yes	Dual Voltage LVCMOS	PU/PD	0		
		mcasep7_axr1		1	IO											
		vin6a_d10	No	7	I											
		timer10		10	IO											
		gpio6_4		14	IO											
		Driver off		15	I											

表 4-2. Ball Characteristics⁽¹⁾ (continued)

BALL NUMBER [1]	BALL NAME [2]	SIGNAL NAME [3]	74x [4]	MUXMODE [5]	TYPE [6]	BALL RESET STATE [7]	BALL RESET REL. STATE [8]	BALL RESET REL. MUXMODE [9]	I/O VOLTAGE VALUE [10]	POWER [11]	HYS [12]	BUFFER TYPE [13]	PULL UP/DOWN TYPE [14]	DSIS [15]	
G14	mcasep1_axr14	mcasep1_axr14		0	IO	PD	PD	15	1.8/3.3	vddshv3	Yes	Dual Voltage LVCMOS	PU/PD	0	
		mcasep7_aclkx		1	IO									0	
		mcasep7_aclkr		2	IO										
		vin6a_d9	No	7	I										0
		timer11		10	IO										
		gpio6_5		14	IO										
		Driver off		15	I										
F14	mcasep1_axr15	mcasep1_axr15		0	IO	PD	PD	15	1.8/3.3	vddshv3	Yes	Dual Voltage LVCMOS	PU/PD	0	
		mcasep7_fsx		1	IO										
		mcasep7_fsr		2	IO										
		vin6a_d8	No	7	I										0
		timer12		10	IO										
		gpio6_6		14	IO										
		Driver off		15	I										
G13	mcasep1_axr2	mcasep1_axr2		0	IO	PD	PD	15	1.8/3.3	vddshv3	Yes	Dual Voltage LVCMOS	PU/PD	0	
		mcasep6_axr2		1	IO										
		uart6_ctsn		3	I										1
		vout2_d2		6	O										
		vin4a_d2		8	I										
		gpio5_4		14	IO										
		Driver off		15	I										
J11	mcasep1_axr3	mcasep1_axr3		0	IO	PD	PD	15	1.8/3.3	vddshv3	Yes	Dual Voltage LVCMOS	PU/PD	0	
		mcasep6_axr3		1	IO										
		uart6_rtsn		3	O										
		vout2_d3		6	O										
		vin4a_d3		8	I										
		gpio5_5		14	IO										
		Driver off		15	I										
E12	mcasep1_axr4	mcasep1_axr4		0	IO	PD	PD	15	1.8/3.3	vddshv3	Yes	Dual Voltage LVCMOS	PU/PD	0	
		mcasep4_axr2		1	IO										
		vout2_d4		6	O										
		vin4a_d4		8	I										
		gpio5_6		14	IO										
		Driver off		15	I										

表 4-2. Ball Characteristics⁽¹⁾ (continued)

BALL NUMBER [1]	BALL NAME [2]	SIGNAL NAME [3]	74x [4]	MUXMODE [5]	TYPE [6]	BALL RESET STATE [7]	BALL RESET REL. STATE [8]	BALL RESET REL. MUXMODE [9]	I/O VOLTAGE VALUE [10]	POWER [11]	HYS [12]	BUFFER TYPE [13]	PULL UP/DOWN TYPE [14]	DSIS [15]
F13	mcasep1_axr5	mcasep1_axr5		0	IO	PD	PD	15	1.8/3.3	vddshv3	Yes	Dual Voltage LVCMOS	PU/PD	0
		mcasep4_axr3		1	IO									0
		vout2_d5		6	O									
		vin4a_d5		8	I									
		gpio5_7		14	IO									
		Driver off		15	I									
C12	mcasep1_axr6	mcasep1_axr6		0	IO	PD	PD	15	1.8/3.3	vddshv3	Yes	Dual Voltage LVCMOS	PU/PD	0
		mcasep5_axr2		1	IO									
		vout2_d6		6	O									
		vin4a_d6		8	I									
		gpio5_8		14	IO									
		Driver off		15	I									
D12	mcasep1_axr7	mcasep1_axr7		0	IO	PD	PD	15	1.8/3.3	vddshv3	Yes	Dual Voltage LVCMOS	PU/PD	0
		mcasep5_axr3		1	IO									
		vout2_d7		6	O									
		vin4a_d7		8	I									
		timer4		10	IO									
		gpio5_9		14	IO									
Driver off		15	I											
B12	mcasep1_axr8	mcasep1_axr8		0	IO	PD	PD	15	1.8/3.3	vddshv3	Yes	Dual Voltage LVCMOS	PU/PD	0
		mcasep6_axr0		1	IO									
		spi3_sclk		3	IO									
		vin6a_d15	No	7	I									
		timer5		10	IO									
		gpio5_10		14	IO									
Driver off		15	I											
A11	mcasep1_axr9	mcasep1_axr9		0	IO	PD	PD	15	1.8/3.3	vddshv3	Yes	Dual Voltage LVCMOS	PU/PD	0
		mcasep6_axr1		1	IO									
		spi3_d1		3	IO									
		vin6a_d14	No	7	I									
		timer6		10	IO									
		gpio5_11		14	IO									
Driver off		15	I											

表 4-2. Ball Characteristics⁽¹⁾ (continued)

BALL NUMBER [1]	BALL NAME [2]	SIGNAL NAME [3]	74x [4]	MUXMODE [5]	TYPE [6]	BALL RESET STATE [7]	BALL RESET REL. STATE [8]	BALL RESET REL. MUXMODE [9]	I/O VOLTAGE VALUE [10]	POWER [11]	HYS [12]	BUFFER TYPE [13]	PULL UP/DOWN TYPE [14]	DSIS [15]
J14	mcasep1_fsr	mcasep1_fsr		0	IO	PD	PD	15	1.8/3.3	vddshv3	Yes	Dual Voltage LVCMOS	PU/PD	0
		mcasep7_axr3		1	IO									0
		vout2_d1		6	O									
		vin4a_d1		8	I									0
		i2c4_scl		10	IO									1
		gpio5_1		14	IO									
		Driver off		15	I									
D14	mcasep1_fsx	mcasep1_fsx		0	IO	PD	PD	15	1.8/3.3	vddshv3	Yes	Dual Voltage LVCMOS	PU/PD	0
		vin6a_de0	No	7	I									0
		i2c3_scl		10	IO									1
		gpio7_30		14	IO									
		Driver off		15	I									
E15	mcasep2_aclkr	mcasep2_aclkr		0	IO	PD	PD	15	1.8/3.3	vddshv3	Yes	Dual Voltage LVCMOS	PU/PD	0
		mcasep8_axr2		1	IO									0
		vout2_d8		6	O									
		vin4a_d8		8	I									0
		Driver off		15	I									
A19	mcasep2_aclkx	mcasep2_aclkx		0	IO	PD	PD	15	1.8/3.3	vddshv3	Yes	Dual Voltage LVCMOS	PU/PD	0
		vin6a_d7	No	7	I									0
		Driver off		15	I									
B15	mcasep2_axr0	mcasep2_axr0		0	IO	PD	PD	15	1.8/3.3	vddshv3	Yes	Dual Voltage LVCMOS	PU/PD	0
		vout2_d10		6	O									
		vin4a_d10		8	I									0
		Driver off		15	I									
A15	mcasep2_axr1	mcasep2_axr1		0	IO	PD	PD	15	1.8/3.3	vddshv3	Yes	Dual Voltage LVCMOS	PU/PD	0
		vout2_d11		6	O									
		vin4a_d11		8	I									0
		Driver off		15	I									
C15	mcasep2_axr2	mcasep2_axr2		0	IO	PD	PD	15	1.8/3.3	vddshv3	Yes	Dual Voltage LVCMOS	PU/PD	0
		mcasep3_axr2		1	IO									0
		vin6a_d5	No	7	I									0
		gpio6_8		14	IO									
		Driver off		15	I									

表 4-2. Ball Characteristics⁽¹⁾ (continued)

BALL NUMBER [1]	BALL NAME [2]	SIGNAL NAME [3]	74x [4]	MUXMODE [5]	TYPE [6]	BALL RESET STATE [7]	BALL RESET REL. STATE [8]	BALL RESET REL. MUXMODE [9]	I/O VOLTAGE VALUE [10]	POWER [11]	HYS [12]	BUFFER TYPE [13]	PULL UP/DOWN TYPE [14]	DSIS [15]
A16	mcasep2_axr3	mcasep2_axr3		0	IO	PD	PD	15	1.8/3.3	vddshv3	Yes	Dual Voltage LVCMOS	PU/PD	0
		mcasep3_axr3		1	IO									0
		vin6a_d4	No	7	I									0
		gpio6_9		14	IO									
		Driver off		15	I									
D15	mcasep2_axr4	mcasep2_axr4		0	IO	PD	PD	15	1.8/3.3	vddshv3	Yes	Dual Voltage LVCMOS	PU/PD	0
		mcasep8_axr0		1	IO									0
		vout2_d12		6	O									
		vin4a_d12		8	I									0
		gpio1_4		14	IO									
		Driver off		15	I									
B16	mcasep2_axr5	mcasep2_axr5		0	IO	PD	PD	15	1.8/3.3	vddshv3	Yes	Dual Voltage LVCMOS	PU/PD	0
		mcasep8_axr1		1	IO									0
		vout2_d13		6	O									
		vin4a_d13		8	I									0
		gpio6_7		14	IO									
		Driver off		15	I									
B17	mcasep2_axr6	mcasep2_axr6		0	IO	PD	PD	15	1.8/3.3	vddshv3	Yes	Dual Voltage LVCMOS	PU/PD	0
		mcasep8_aclkx		1	IO									0
		mcasep8_aclkr		2	IO									
		vout2_d14		6	O									
		vin4a_d14		8	I									0
		gpio2_29		14	IO									
		Driver off		15	I									
A17	mcasep2_axr7	mcasep2_axr7		0	IO	PD	PD	15	1.8/3.3	vddshv3	Yes	Dual Voltage LVCMOS	PU/PD	0
		mcasep8_fsx		1	IO									0
		mcasep8_fsr		2	IO									
		vout2_d15		6	O									
		vin4a_d15		8	I									0
		gpio1_5		14	IO									
		Driver off		15	I									
A20	mcasep2_fsr	mcasep2_fsr		0	IO	PD	PD	15	1.8/3.3	vddshv3	Yes	Dual Voltage LVCMOS	PU/PD	0
		mcasep8_axr3		1	IO									0
		vout2_d9		6	O									
		vin4a_d9		8	I									0
		Driver off		15	I									

表 4-2. Ball Characteristics⁽¹⁾ (continued)

BALL NUMBER [1]	BALL NAME [2]	SIGNAL NAME [3]	74x [4]	MUXMODE [5]	TYPE [6]	BALL RESET STATE [7]	BALL RESET REL. STATE [8]	BALL RESET REL. MUXMODE [9]	I/O VOLTAGE VALUE [10]	POWER [11]	HYS [12]	BUFFER TYPE [13]	PULL UP/DOWN TYPE [14]	DSIS [15]
A18	mcasep2_fsx	mcasep2_fsx		0	IO	PD	PD	15	1.8/3.3	vddshv3	Yes	Dual Voltage LVCMOS	PU/PD	0
		vin6a_d6	No	7	I									0
		Driver off		15	I									
B18	mcasep3_aclkx	mcasep3_aclkx		0	IO	PD	PD	15	1.8/3.3	vddshv3	Yes	Dual Voltage LVCMOS	PU/PD	0
		mcasep3_aclkr		1	IO									
		mcasep2_axr12		2	IO									0
		uart7_rxd		3	I									1
		vin6a_d3	No	7	I									0
		gpio5_13		14	IO									
		Driver off		15	I									
B19	mcasep3_axr0	mcasep3_axr0		0	IO	PD	PD	15	1.8/3.3	vddshv3	Yes	Dual Voltage LVCMOS	PU/PD	0
		mcasep2_axr14		2	IO									0
		uart7_ctsn		3	I									1
		uart5_rxd		4	I									1
		vin6a_d1	No	7	I									0
		Driver off		15	I									
C17	mcasep3_axr1	mcasep3_axr1		0	IO	PD	PD	15	1.8/3.3	vddshv3	Yes	Dual Voltage LVCMOS	PU/PD	0
		mcasep2_axr15		2	IO									0
		uart7_rtsn		3	O									
		uart5_txd		4	O									
		vin6a_d0	No	7	I									0
		vin5a_fld0	No	9	I									0
		Driver off		15	I									
F15	mcasep3_fsx	mcasep3_fsx		0	IO	PD	PD	15	1.8/3.3	vddshv3	Yes	Dual Voltage LVCMOS	PU/PD	0
		mcasep3_fsr		1	IO									
		mcasep2_axr13		2	IO									0
		uart7_txd		3	O									
		vin6a_d2	No	7	I									0
		gpio5_14		14	IO									
		Driver off		15	I									

表 4-2. Ball Characteristics⁽¹⁾ (continued)

BALL NUMBER [1]	BALL NAME [2]	SIGNAL NAME [3]	74x [4]	MUXMODE [5]	TYPE [6]	BALL RESET STATE [7]	BALL RESET REL. STATE [8]	BALL RESET REL. MUXMODE [9]	I/O VOLTAGE VALUE [10]	POWER [11]	HYS [12]	BUFFER TYPE [13]	PULL UP/DOWN TYPE [14]	DSIS [15]		
C18	mcasep4_aclkx	mcasep4_aclkx		0	IO	PD	PD	15	1.8/3.3	vddshv3	Yes	Dual Voltage LVCMOS	PU/PD	0		
		mcasep4_aclkr		1	IO											
		spi3_sclk		2	IO											0
		uart8_rxd		3	I											1
		i2c4_sda		4	IO											1
		vout2_d16		6	O											
		vin4a_d16		8	I											0
		vin5a_d15	No	9	I											0
		Driver off		15	I											
G16	mcasep4_axr0	mcasep4_axr0		0	IO	PD	PD	15	1.8/3.3	vddshv3	Yes	Dual Voltage LVCMOS	PU/PD	0		
		spi3_d0		2	IO											0
		uart8_ctsn		3	I											1
		uart4_rxd		4	I											1
		vout2_d18		6	O											
		vin4a_d18		8	I											0
		vin5a_d13	No	9	I											0
		Driver off		15	I											
D17	mcasep4_axr1	mcasep4_axr1		0	IO	PD	PD	15	1.8/3.3	vddshv3	Yes	Dual Voltage LVCMOS	PU/PD	0		
		spi3_cs0		2	IO											1
		uart8_rtsn		3	O											
		uart4_txd		4	O											
		vout2_d19		6	O											
		vin4a_d19		8	I											0
		vin5a_d12	No	9	I											0
		Driver off		15	I											
A21	mcasep4_fsx	mcasep4_fsx		0	IO	PD	PD	15	1.8/3.3	vddshv3	Yes	Dual Voltage LVCMOS	PU/PD	0		
		mcasep4_fsr		1	IO											
		spi3_d1		2	IO											0
		uart8_txd		3	O											
		i2c4_scl		4	IO											1
		vout2_d17		6	O											
		vin4a_d17		8	I											0
		vin5a_d14	No	9	I											0
		Driver off		15	I											

表 4-2. Ball Characteristics⁽¹⁾ (continued)

BALL NUMBER [1]	BALL NAME [2]	SIGNAL NAME [3]	74x [4]	MUXMODE [5]	TYPE [6]	BALL RESET STATE [7]	BALL RESET REL. STATE [8]	BALL RESET REL. MUXMODE [9]	I/O VOLTAGE VALUE [10]	POWER [11]	HYS [12]	BUFFER TYPE [13]	PULL UP/DOWN TYPE [14]	DSIS [15]		
AA3	mcasep5_aclkx	mcasep5_aclkx		0	IO	PD	PD	15	1.8/3.3	vddshv7	Yes	Dual Voltage LVCMOS	PU/PD	0		
		mcasep5_aclkr		1	IO											
		spi4_sclk		2	IO											0
		uart9_rxd		3	I											1
		i2c5_sda		4	IO											1
		mlb_clk		5	I											1
		vout2_d20		6	O											
		vin4a_d20		8	I											0
		vin5a_d11	No	9	I											0
		Driver off		15	I											
AB3	mcasep5_axr0	mcasep5_axr0		0	IO	PD	PD	15	1.8/3.3	vddshv7	Yes	Dual Voltage LVCMOS	PU/PD	0		
		spi4_d0		2	IO											0
		uart9_ctsn		3	I											1
		uart3_rxd		4	I											1
		mlb_sig		5	IO											1
		vout2_d22		6	O											
		vin4a_d22		8	I											0
		vin5a_d9	No	9	I											0
		Driver off		15	I											
		AA4	mcasep5_axr1	mcasep5_axr1		0	IO	PD	PD	15	1.8/3.3			vddshv7	Yes	Dual Voltage LVCMOS
spi4_cs0				2	IO									1		
uart9_rtsn				3	O											
uart3_txd				4	O											
mlb_dat				5	IO									1		
vout2_d23				6	O											
vin4a_d23				8	I									0		
vin5a_d8	No			9	I									0		
Driver off				15	I											
AB9	mcasep5_fsx			mcasep5_fsx		0	IO	PD	PD	15	1.8/3.3	vddshv7	Yes	Dual Voltage LVCMOS	PU/PD	
		mcasep5_fsr		1	IO											
		spi4_d1		2	IO											0
		uart9_txd		3	O											
		i2c5_scl		4	IO											1
		vout2_d21		6	O											
		vin4a_d21		8	I											0
		vin5a_d10	No	9	I											0
		Driver off		15	I											

表 4-2. Ball Characteristics⁽¹⁾ (continued)

BALL NUMBER [1]	BALL NAME [2]	SIGNAL NAME [3]	74x [4]	MUXMODE [5]	TYPE [6]	BALL RESET STATE [7]	BALL RESET REL. STATE [8]	BALL RESET REL. MUXMODE [9]	I/O VOLTAGE VALUE [10]	POWER [11]	HYS [12]	BUFFER TYPE [13]	PULL UP/DOWN TYPE [14]	DSIS [15]
U4	mdio_d	mdio_d		0	IO	PU	PU	15	1.8/3.3	vddshv9	Yes	Dual Voltage LVCMOS	PU/PD	1
		uart3_ctsn		1	I									1
		mii0_txer		3	O									0
		vin2a_d0		4	I									0
		vin4b_d0		5	I									0
		gpio5_16		14	IO									
		Driver off		15	I									
V1	mdio_mclk	mdio_mclk		0	O	PU	PU	15	1.8/3.3	vddshv9	Yes	Dual Voltage LVCMOS	PU/PD	1
		uart3_rtsn		1	O									
		mii0_col		3	I									0
		vin2a_clk0		4	I									
		vin4b_clk1		5	I									0
		gpio5_15		14	IO									
		Driver off		15	I									
AB2	mlbp_clk_n	mlbp_clk_n		0	I				1.8	vdds_mlbp	No	ILVDS18		
AB1	mlbp_clk_p	mlbp_clk_p		0	I				1.8	vdds_mlbp	No	ILVDS18		
AA2	mlbp_dat_n	mlbp_dat_n		0	IO	OFF	OFF		1.8	vdds_mlbp	No	BMLB18		
AA1	mlbp_dat_p	mlbp_dat_p		0	IO	OFF	OFF		1.8	vdds_mlbp	No	BMLB18		
AC2	mlbp_sig_n	mlbp_sig_n		0	IO	OFF	OFF		1.8	vdds_mlbp	No	BMLB18		
AC1	mlbp_sig_p	mlbp_sig_p		0	IO	OFF	OFF		1.8	vdds_mlbp	No	BMLB18		
W6	mmc1_clk	mmc1_clk		0	IO	PU	PU	15	1.8/3.3	vddshv8	Yes	SDIO1833	PU/PD	1
		gpio6_21		14	IO									
		Driver off		15	I									
Y6	mmc1_cmd	mmc1_cmd		0	IO	PU	PU	15	1.8/3.3	vddshv8	Yes	SDIO1833	PU/PD	1
		gpio6_22		14	IO									
		Driver off		15	I									
AA6	mmc1_dat0	mmc1_dat0		0	IO	PU	PU	15	1.8/3.3	vddshv8	Yes	SDIO1833	PU/PD	1
		gpio6_23		14	IO									
		Driver off		15	I									
Y4	mmc1_dat1	mmc1_dat1		0	IO	PU	PU	15	1.8/3.3	vddshv8	Yes	SDIO1833	PU/PD	1
		gpio6_24		14	IO									
		Driver off		15	I									
AA5	mmc1_dat2	mmc1_dat2		0	IO	PU	PU	15	1.8/3.3	vddshv8	Yes	SDIO1833	PU/PD	1
		gpio6_25		14	IO									
		Driver off		15	I									

表 4-2. Ball Characteristics⁽¹⁾ (continued)

BALL NUMBER [1]	BALL NAME [2]	SIGNAL NAME [3]	74x [4]	MUXMODE [5]	TYPE [6]	BALL RESET STATE [7]	BALL RESET REL. STATE [8]	BALL RESET REL. MUXMODE [9]	I/O VOLTAGE VALUE [10]	POWER [11]	HYS [12]	BUFFER TYPE [13]	PULL UP/DOWN TYPE [14]	DSIS [15]
Y3	mmc1_dat3	mmc1_dat3		0	IO	PU	PU	15	1.8/3.3	vddshv8	Yes	SDIO1833	PU/PD	1
		gpio6_26		14	IO									
		Driver off		15	I									
W7	mmc1_sdcd	mmc1_sdcd		0	I	PU	PU	15	1.8/3.3	vddshv8	Yes	Dual Voltage LVCMOS	PU/PD	1
		uart6_rxd		3	I									1
		i2c4_sda		4	IO									1
		gpio6_27		14	IO									
		Driver off		15	I									
Y9	mmc1_sdwpx	mmc1_sdwpx		0	I	PD	PD	15	1.8/3.3	vddshv8	Yes	Dual Voltage LVCMOS	PU/PD	0
		uart6_txd		3	O									
		i2c4_scl		4	IO									1
		gpio6_28		14	IO									
		Driver off		15	I									
AD4	mmc3_clk	mmc3_clk		0	IO	PU	PU	15	1.8/3.3	vddshv7	Yes	Dual Voltage LVCMOS	PU/PD	1
		usb3_ulpi_d5		3	IO									0
		vin2b_d7		4	I									0
		vin5a_d7	No	9	I									0
		ehrpwm2_tripzone_input		10	IO									0
		gpio6_29		14	IO									
		Driver off		15	I									
AC4	mmc3_cmd	mmc3_cmd		0	IO	PU	PU	15	1.8/3.3	vddshv7	Yes	Dual Voltage LVCMOS	PU/PD	1
		spi3_sclk		1	IO									0
		usb3_ulpi_d4		3	IO									0
		vin2b_d6		4	I									0
		vin5a_d6	No	9	I									0
		eCAP2_in_PWM2_out		10	IO									0
		gpio6_30		14	IO									
		Driver off		15	I									
AC7	mmc3_dat0	mmc3_dat0		0	IO	PU	PU	15	1.8/3.3	vddshv7	Yes	Dual Voltage LVCMOS	PU/PD	1
		spi3_d1		1	IO									0
		uart5_rxd		2	I									1
		usb3_ulpi_d3		3	IO									0
		vin2b_d5		4	I									0
		vin5a_d5	No	9	I									0
		eQEP3A_in		10	I									0
		gpio6_31		14	IO									
Driver off		15	I											

表 4-2. Ball Characteristics⁽¹⁾ (continued)

BALL NUMBER [1]	BALL NAME [2]	SIGNAL NAME [3]	74x [4]	MUXMODE [5]	TYPE [6]	BALL RESET STATE [7]	BALL RESET REL. STATE [8]	BALL RESET REL. MUXMODE [9]	I/O VOLTAGE VALUE [10]	POWER [11]	HYS [12]	BUFFER TYPE [13]	PULL UP/DOWN TYPE [14]	DSIS [15]
AC6	mmc3_dat1	mmc3_dat1		0	IO	PU	PU	15	1.8/3.3	vddshv7	Yes	Dual Voltage LVCMOS	PU/PD	1
		spi3_d0		1	IO									0
		uart5_txd		2	O									
		usb3_ulpi_d2		3	IO									0
		vin2b_d4		4	I									0
		vin5a_d4	No	9	I									0
		eQEP3B_in		10	I									0
		gpio7_0		14	IO									
Driver off		15	I											
AC9	mmc3_dat2	mmc3_dat2		0	IO	PU	PU	15	1.8/3.3	vddshv7	Yes	Dual Voltage LVCMOS	PU/PD	1
		spi3_cs0		1	IO									1
		uart5_ctsn		2	I									1
		usb3_ulpi_d1		3	IO									0
		vin2b_d3		4	I									0
		vin5a_d3	No	9	I									0
		eQEP3_index		10	IO									0
		gpio7_1		14	IO									
Driver off		15	I											
AC3	mmc3_dat3	mmc3_dat3		0	IO	PU	PU	15	1.8/3.3	vddshv7	Yes	Dual Voltage LVCMOS	PU/PD	1
		spi3_cs1		1	IO									1
		uart5_rtsn		2	O									
		usb3_ulpi_d0		3	IO									0
		vin2b_d2		4	I									0
		vin5a_d2	No	9	I									0
		eQEP3_strobe		10	IO									0
		gpio7_2		14	IO									
Driver off		15	I											
AC8	mmc3_dat4	mmc3_dat4		0	IO	PU	PU	15	1.8/3.3	vddshv7	Yes	Dual Voltage LVCMOS	PU/PD	1
		spi4_sclk		1	IO									0
		uart10_rxd		2	I									1
		usb3_ulpi_next		3	I									0
		vin2b_d1		4	I									0
		vin5a_d1	No	9	I									0
		ehrpwm3A		10	O									
		gpio1_22		14	IO									
Driver off		15	I											

表 4-2. Ball Characteristics⁽¹⁾ (continued)

BALL NUMBER [1]	BALL NAME [2]	SIGNAL NAME [3]	74x [4]	MUXMODE [5]	TYPE [6]	BALL RESET STATE [7]	BALL RESET REL. STATE [8]	BALL RESET REL. MUXMODE [9]	I/O VOLTAGE VALUE [10]	POWER [11]	HYS [12]	BUFFER TYPE [13]	PULL UP/DOWN TYPE [14]	DSIS [15]		
AD6	mmc3_dat5	mmc3_dat5		0	IO	PU	PU	15	1.8/3.3	vddshv7	Yes	Dual Voltage LVCMOS	PU/PD	1		
		spi4_d1		1	IO									0		
		uart10_txd		2	O										0	
		usb3_ulpi_dir		3	I										0	
		vin2b_d0		4	I										0	
		vin5a_d0	No	9	I										0	
		ehrpwm3B		10	O											
		gpio1_23		14	IO											
		Driver off		15	I											
AB8	mmc3_dat6	mmc3_dat6		0	IO	PU	PU	15	1.8/3.3	vddshv7	Yes	Dual Voltage LVCMOS	PU/PD	1		
		spi4_d0		1	IO										0	
		uart10_ctsn		2	I										1	
		usb3_ulpi_stp		3	O											
		vin2b_de1		4	I											
		vin5a_hsync0	No	9	I										0	
		ehrpwm3_tripzone_input		10	IO										0	
		gpio1_24		14	IO											
		Driver off		15	I											
AB5	mmc3_dat7	mmc3_dat7		0	IO	PU	PU	15	1.8/3.3	vddshv7	Yes	Dual Voltage LVCMOS	PU/PD	1		
		spi4_cs0		1	IO										1	
		uart10_rtsn		2	O											
		usb3_ulpi_clk		3	I										0	
		vin2b_clk1		4	I											
		vin5a_vsync0	No	9	I										0	
		eCAP3_in_PWM3_out		10	IO										0	
		gpio1_25		14	IO											
		Driver off		15	I											
D21	nmin_dsp	nmin_dsp		0	I	PD	PD		1.8/3.3	vddshv3	Yes	Dual Voltage LVCMOS	PU/PD			
Y11	on_off	on_off		0	O	PU	drive 1 (OFF)		1.8/3.3	vddshv5	Yes	BC1833IHH V	PU/PD			
AG13	pcie_rxn0	pcie_rxn0		0	I	OFF	OFF		1.8	vdda_pcie0		SERDES				
AG11	pcie_rxn1	pcie_rxn1	No	0	I	OFF	OFF		1.8	vdda_pcie1		SERDES				
AH13	pcie_rxp0	pcie_rxp0		0	I	OFF	OFF		1.8	vdda_pcie0		SERDES				
AH11	pcie_rxp1	pcie_rxp1	No	0	I	OFF	OFF		1.8	vdda_pcie1		SERDES				
AG14	pcie_txn0	pcie_txn0		0	O				1.8	vdda_pcie0		SERDES				
AG12	pcie_txn1	pcie_txn1	No	0	O				1.8	vdda_pcie1		SERDES				

表 4-2. Ball Characteristics⁽¹⁾ (continued)

BALL NUMBER [1]	BALL NAME [2]	SIGNAL NAME [3]	74x [4]	MUXMODE [5]	TYPE [6]	BALL RESET STATE [7]	BALL RESET REL. STATE [8]	BALL RESET REL. MUXMODE [9]	I/O VOLTAGE VALUE [10]	POWER [11]	HYS [12]	BUFFER TYPE [13]	PULL UP/DOWN TYPE [14]	DSIS [15]
AH14	pcie_txp0	pcie_txp0		0	O				1.8	vdda_pcie0		SERDES		
AH12	pcie_txp1	pcie_txp1	No	0	O				1.8	vdda_pcie1		SERDES		
F22	porz	porz		0	I				1.8/3.3	vddshv3	Yes	IHHV1833	PU/PD	
E23	resetrn	resetrn		0	I	PU	PU		1.8/3.3	vddshv3	Yes	Dual Voltage LVCMOS	PU/PD	
U5	rgmii0_rxc	rgmii0_rxc		0	I	PD	PD	15	1.8/3.3	vddshv9	Yes	Dual Voltage LVCMOS	PU/PD	0
		rmii1_txen		2	O									
		mii0_txclk		3	I									
		vin2a_d5		4	I									
		vin4b_d5		5	I									
		usb4_ulpi_d2		6	IO									
		gpio5_26		14	IO									
Driver off		15	I											
V5	rgmii0_rxctl	rgmii0_rxctl		0	I	PD	PD	15	1.8/3.3	vddshv9	Yes	Dual Voltage LVCMOS	PU/PD	0
		rmii1_txd1		2	O									
		mii0_txd3		3	O									
		vin2a_d6		4	I									
		vin4b_d6		5	I									
		usb4_ulpi_d3		6	IO									
		gpio5_27		14	IO									
Driver off		15	I											
W2	rgmii0_rxd0	rgmii0_rxd0		0	I	PD	PD	15	1.8/3.3	vddshv9	Yes	Dual Voltage LVCMOS	PU/PD	0
		rmii0_txd0		1	O									
		mii0_txd0		3	O									
		vin2a_fld0		4	I									
		vin4b_fld1		5	I									
		usb4_ulpi_d7		6	IO									
		gpio5_31		14	IO									
Driver off		15	I											
Y2	rgmii0_rxd1	rgmii0_rxd1		0	I	PD	PD	15	1.8/3.3	vddshv9	Yes	Dual Voltage LVCMOS	PU/PD	0
		rmii0_txd1		1	O									
		mii0_txd1		3	O									
		vin2a_d9		4	I									
		usb4_ulpi_d6		6	IO									
		gpio5_30		14	IO									
		Driver off		15	I									

表 4-2. Ball Characteristics⁽¹⁾ (continued)

BALL NUMBER [1]	BALL NAME [2]	SIGNAL NAME [3]	74x [4]	MUXMODE [5]	TYPE [6]	BALL RESET STATE [7]	BALL RESET REL. STATE [8]	BALL RESET REL. MUXMODE [9]	I/O VOLTAGE VALUE [10]	POWER [11]	HYS [12]	BUFFER TYPE [13]	PULL UP/DOWN TYPE [14]	DSIS [15]			
V3	rgmii0_rxd2	rgmii0_rxd2		0	I	PD	PD	15	1.8/3.3	vddshv9	Yes	Dual Voltage LVCMOS	PU/PD	0			
		rmii0_txen		1	O												
		mii0_txen		3	O												
		vin2a_d8		4	I											0	
		usb4_ulpi_d5		6	IO												0
		gpio5_29		14	IO												
		Driver off		15	I												
V4	rgmii0_rxd3	rgmii0_rxd3		0	I	PD	PD	15	1.8/3.3	vddshv9	Yes	Dual Voltage LVCMOS	PU/PD	0			
		rmii1_txd0		2	O												
		mii0_txd2		3	O												
		vin2a_d7		4	I											0	
		vin4b_d7		5	I												0
		usb4_ulpi_d4		6	IO												0
		gpio5_28		14	IO												
		Driver off		15	I												
W9	rgmii0_txc	rgmii0_txc		0	O	PD	PD	15	1.8/3.3	vddshv9	Yes	Dual Voltage LVCMOS	PU/PD				
		uart3_ctsn		1	I											1	
		rmii1_rxd1		2	I											0	
		mii0_rxd3		3	I											0	
		vin2a_d3		4	I												0
		vin4b_d3		5	I												0
		usb4_ulpi_clk		6	I												0
		spi3_d0		7	IO												0
		spi4_cs2		8	IO												1
		gpio5_20		14	IO												
		Driver off		15	I												
V9	rgmii0_txcctl	rgmii0_txcctl		0	O	PD	PD	15	1.8/3.3	vddshv9	Yes	Dual Voltage LVCMOS	PU/PD				
		uart3_rtsn		1	O												
		rmii1_rxd0		2	I											0	
		mii0_rxd2		3	I											0	
		vin2a_d4		4	I												0
		vin4b_d4		5	I												0
		usb4_ulpi_stp		6	O												
		spi3_cs0		7	IO												1
		spi4_cs3		8	IO												1
		gpio5_21		14	IO												
		Driver off		15	I												

表 4-2. Ball Characteristics⁽¹⁾ (continued)

BALL NUMBER [1]	BALL NAME [2]	SIGNAL NAME [3]	74x [4]	MUXMODE [5]	TYPE [6]	BALL RESET STATE [7]	BALL RESET REL. STATE [8]	BALL RESET REL. MUXMODE [9]	I/O VOLTAGE VALUE [10]	POWER [11]	HYS [12]	BUFFER TYPE [13]	PULL UP/DOWN TYPE [14]	DSIS [15]
U6	rgmii0_txd0	rgmii0_txd0		0	O	PD	PD	15	1.8/3.3	vddshv9	Yes	Dual Voltage LVCMOS	PU/PD	
		rmii0_rxd0		1	I									0
		mii0_rxd0		3	I									0
		vin2a_d10		4	I									0
		usb4_ulpi_d1		6	IO									0
		spi4_cs0		7	IO									1
		uart4_rtsn		8	O									
		gpio5_25		14	IO									
Driver off		15	I											
V6	rgmii0_txd1	rgmii0_txd1		0	O	PD	PD	15	1.8/3.3	vddshv9	Yes	Dual Voltage LVCMOS	PU/PD	
		rmii0_rxd1		1	I									0
		mii0_rxd1		3	I									0
		vin2a_vsync0		4	I									0
		vin4b_vsync1		5	I									0
		usb4_ulpi_d0		6	IO									0
		spi4_d0		7	IO									0
		uart4_ctsn		8	IO									1
gpio5_24		14	IO											
Driver off		15	I											
U7	rgmii0_txd2	rgmii0_txd2		0	O	PD	PD	15	1.8/3.3	vddshv9	Yes	Dual Voltage LVCMOS	PU/PD	
		rmii0_rxer		1	I									0
		mii0_rxer		3	I									0
		vin2a_hsync0		4	I									0
		vin4b_hsync1		5	I									0
		usb4_ulpi_nxt		6	I									0
		spi4_d1		7	IO									0
		uart4_txd		8	O									
gpio5_23		14	IO											
Driver off		15	I											

表 4-2. Ball Characteristics⁽¹⁾ (continued)

BALL NUMBER [1]	BALL NAME [2]	SIGNAL NAME [3]	74x [4]	MUXMODE [5]	TYPE [6]	BALL RESET STATE [7]	BALL RESET REL. STATE [8]	BALL RESET REL. MUXMODE [9]	I/O VOLTAGE VALUE [10]	POWER [11]	HYS [12]	BUFFER TYPE [13]	PULL UP/DOWN TYPE [14]	DSIS [15]
V7	rgmii0_txd3	rgmii0_txd3		0	O	PD	PD	15	1.8/3.3	vddshv9	Yes	Dual Voltage LVCMOS	PU/PD	
		rmii0_crs		1	I									0
		mii0_crs		3	I									0
		vin2a_de0		4	I									
		vin4b_de1		5	I									0
		usb4_ulpi_dir		6	I									0
		spi4_sclk		7	IO									0
		uart4_rxd		8	I									1
		gpio5_22		14	IO									
		Driver off		15	I									
U3	RMII_MHZ_50_CLK	RMII_MHZ_50_CLK		0	IO	PD	PD	15	1.8/3.3	vddshv9	Yes	Dual Voltage LVCMOS	PU/PD	0
		vin2a_d11		4	I									0
		gpio5_17		14	IO									
		Driver off		15	I									
F23	rstoutn	rstoutn		0	O	PD	drive 1 (OFF)		1.8/3.3	vddshv3	Yes	Dual Voltage LVCMOS	PU/PD	
E18	rtck	rtck		0	O	PU	drive clk (OFF)	0	1.8/3.3	vddshv3	Yes	Dual Voltage LVCMOS	PU/PD	
		gpio8_29		14	IO									
AF14	rtc_iso	rtc_iso		0	I				1.8/3.3	vddshv5	Yes	IHHV1833	PU/PD	
AE14	rtc_osc_xi_clkin32	rtc_osc_xi_clkin32		0	I				1.8	vdda_rtc	No	LVCMOS OSC		
AD14	rtc_osc_xo	rtc_osc_xo		0	O				1.8	vdda_rtc	No	LVCMOS OSC		
AB17	rtc_porz	rtc_porz		0	I				1.8/3.3	vddshv5	Yes	IHHV1833	PU/PD	
AH9	sata1_rxn0	sata1_rxn0		0	I	OFF	OFF		1.8	vdda_sata		SATAPHY		
AG9	sata1_rxp0	sata1_rxp0		0	I	OFF	OFF		1.8	vdda_sata		SATAPHY		
AG10	sata1_txn0	sata1_txn0		0	O				1.8	vdda_sata		SATAPHY		
AH10	sata1_txp0	sata1_txp0		0	O				1.8	vdda_sata		SATAPHY		
A24	spi1_cs0	spi1_cs0		0	IO	PU	PU	15	1.8/3.3	vddshv3	Yes	Dual Voltage LVCMOS	PU/PD	1
		gpio7_10		14	IO									
		Driver off		15	I									
A22	spi1_cs1	spi1_cs1		0	IO	PU	PU	15	1.8/3.3	vddshv3	Yes	Dual Voltage LVCMOS	PU/PD	1
		sata1_led		2	O									
		spi2_cs1		3	IO									1
		gpio7_11		14	IO									
		Driver off		15	I									

表 4-2. Ball Characteristics⁽¹⁾ (continued)

BALL NUMBER [1]	BALL NAME [2]	SIGNAL NAME [3]	74x [4]	MUXMODE [5]	TYPE [6]	BALL RESET STATE [7]	BALL RESET REL. STATE [8]	BALL RESET REL. MUXMODE [9]	I/O VOLTAGE VALUE [10]	POWER [11]	HYS [12]	BUFFER TYPE [13]	PULL UP/DOWN TYPE [14]	DSIS [15]	
B21	spi1_cs2	spi1_cs2		0	IO	PU	PU	15	1.8/3.3	vddshv3	Yes	Dual Voltage LVCMOS	PU/PD	1	
		uart4_rxd		1	I										1
		mmc3_sdcd		2	I										1
		spi2_cs2		3	IO										1
		dcan2_tx		4	IO										1
		mdio_mclk		5	O										1
		hdmi1_hpd		6	I										
		gpio7_12		14	IO										
	Driver off		15	I											
B20	spi1_cs3	spi1_cs3		0	IO	PU	PU	15	1.8/3.3	vddshv3	Yes	Dual Voltage LVCMOS	PU/PD	1	
		uart4_txd		1	O										
		mmc3_sdwpc		2	I										0
		spi2_cs3		3	IO										1
		dcan2_rx		4	IO										1
		mdio_d		5	IO										1
		hdmi1_cec		6	IO										
		gpio7_13		14	IO										
	Driver off		15	I											
B25	spi1_d0	spi1_d0		0	IO	PD	PD	15	1.8/3.3	vddshv3	Yes	Dual Voltage LVCMOS	PU/PD	0	
		gpio7_9		14	IO										
		Driver off		15	I										
F16	spi1_d1	spi1_d1		0	IO	PD	PD	15	1.8/3.3	vddshv3	Yes	Dual Voltage LVCMOS	PU/PD	0	
		gpio7_8		14	IO										
		Driver off		15	I										
A25	spi1_sclk	spi1_sclk		0	IO	PD	PD	15	1.8/3.3	vddshv3	Yes	Dual Voltage LVCMOS	PU/PD	0	
		gpio7_7		14	IO										
		Driver off		15	I										
B24	spi2_cs0	spi2_cs0		0	IO	PU	PU	15	1.8/3.3	vddshv3	Yes	Dual Voltage LVCMOS	PU/PD	1	
		uart3_rtsn		1	O										
		uart5_txd		2	O										
		gpio7_17		14	IO										
		Driver off		15	I										
G17	spi2_d0	spi2_d0		0	IO	PD	PD	15	1.8/3.3	vddshv3	Yes	Dual Voltage LVCMOS	PU/PD	0	
		uart3_ctsn		1	I										
		uart5_rxd		2	I										
		gpio7_16		14	IO										
		Driver off		15	I										

表 4-2. Ball Characteristics⁽¹⁾ (continued)

BALL NUMBER [1]	BALL NAME [2]	SIGNAL NAME [3]	74x [4]	MUXMODE [5]	TYPE [6]	BALL RESET STATE [7]	BALL RESET REL. STATE [8]	BALL RESET REL. MUXMODE [9]	I/O VOLTAGE VALUE [10]	POWER [11]	HYS [12]	BUFFER TYPE [13]	PULL UP/DOWN TYPE [14]	DSIS [15]						
B22	spi2_d1	spi2_d1		0	IO	PD	PD	15	1.8/3.3	vddshv3	Yes	Dual Voltage LVCMOS	PU/PD	0						
		uart3_txd		1	O															
		gpio7_15		14	IO															
		Driver off		15	I															
A26	spi2_sclk	spi2_sclk		0	IO	PD	PD	15	1.8/3.3	vddshv3	Yes	Dual Voltage LVCMOS	PU/PD	0						
		uart3_rxd		1	I										1					
		gpio7_14		14	IO															
		Driver off		15	I															
E20	tclk	tclk		0	I	PU	PU	0	1.8/3.3	vddshv3	Yes	IQ1833	PU/PD							
D23	tdi	tdi		0	I	PU	PU	0	1.8/3.3	vddshv3	Yes	Dual Voltage LVCMOS	PU/PD							
		gpio8_27		14	I															
F19	tdo	tdo		0	O	PU	PU	0	1.8/3.3	vddshv3	Yes	Dual Voltage LVCMOS	PU/PD							
		gpio8_28		14	IO															
F18	tms	tms		0	IO	OFF	OFF	0	1.8/3.3	vddshv3	Yes	Dual Voltage LVCMOS	PU/PD							
D20	trstn	trstn		0	I	PD	PD		1.8/3.3	vddshv3	Yes	Dual Voltage LVCMOS	PU/PD							
E25	uart1_ctsn	uart1_ctsn		0	I	PU	PU	15	1.8/3.3	vddshv4	Yes	Dual Voltage LVCMOS	PU/PD	1						
		uart9_rxd		2	I															1
		mmc4_clk		3	IO															1
		gpio7_24		14	IO															
		Driver off		15	I															
C27	uart1_rtsn	uart1_rtsn		0	O	PU	PU	15	1.8/3.3	vddshv4	Yes	Dual Voltage LVCMOS	PU/PD							
		uart9_txd		2	O															
		mmc4_cmd		3	IO															1
		gpio7_25		14	IO															
		Driver off		15	I															
B27	uart1_rxd	uart1_rxd		0	I	PU	PU	15	1.8/3.3	vddshv4	Yes	Dual Voltage LVCMOS	PU/PD	1						
		mmc4_sdccl		3	I															1
		gpio7_22		14	IO															
		Driver off		15	I															
C26	uart1_txd	uart1_txd		0	O	PU	PU	15	1.8/3.3	vddshv4	Yes	Dual Voltage LVCMOS	PU/PD	0						
		mmc4_sdwp		3	I															
		gpio7_23		14	IO															
		Driver off		15	I															

表 4-2. Ball Characteristics⁽¹⁾ (continued)

BALL NUMBER [1]	BALL NAME [2]	SIGNAL NAME [3]	74x [4]	MUXMODE [5]	TYPE [6]	BALL RESET STATE [7]	BALL RESET REL. STATE [8]	BALL RESET REL. MUXMODE [9]	I/O VOLTAGE VALUE [10]	POWER [11]	HYS [12]	BUFFER TYPE [13]	PULL UP/DOWN TYPE [14]	DSIS [15]
D27	uart2_ctsn	uart2_ctsn		0	I	PU	PU	15	1.8/3.3	vddshv4	Yes	Dual Voltage LVCMOS	PU/PD	1
		uart3_rxd		2	I									1
		mmc4_dat2		3	IO									1
		uart10_rxd		4	I									1
		uart1_dtrn		5	O									
		gpio1_16		14	IO									
		Driver off		15	I									
C28	uart2_rtsn	uart2_rtsn		0	O	PU	PU	15	1.8/3.3	vddshv4	Yes	Dual Voltage LVCMOS	PU/PD	
		uart3_txd		1	O									
		uart3_irtx		2	O									
		mmc4_dat3		3	IO									1
		uart10_txd		4	O									
		uart1_rin		5	I									1
		gpio1_17		14	IO									
Driver off		15	I											
D28	uart2_rxd	uart3_ctsn		1	I	PU	PU	15	1.8/3.3	vddshv4	Yes	Dual Voltage LVCMOS	PU/PD	1
		uart3_rctx		2	O									
		mmc4_dat0		3	IO									1
		uart2_rxd		4	I									1
		uart1_dcdn		5	I									1
		gpio7_26		14	IO									
		Driver off		15	I									
D26	uart2_txd	uart2_txd		0	O	PU	PU	15	1.8/3.3	vddshv4	Yes	Dual Voltage LVCMOS	PU/PD	
		uart3_rtsn		1	O									
		uart3_sd		2	O									
		mmc4_dat1		3	IO									1
		uart2_txd		4	O									
		uart1_dsm		5	I									0
		gpio7_27		14	IO									
Driver off		15	I											

表 4-2. Ball Characteristics⁽¹⁾ (continued)

BALL NUMBER [1]	BALL NAME [2]	SIGNAL NAME [3]	74x [4]	MUXMODE [5]	TYPE [6]	BALL RESET STATE [7]	BALL RESET REL. STATE [8]	BALL RESET REL. MUXMODE [9]	I/O VOLTAGE VALUE [10]	POWER [11]	HYS [12]	BUFFER TYPE [13]	PULL UP/DOWN TYPE [14]	DSIS [15]
V2	uart3_rxd	uart3_rxd		0	I	PD	PD	15	1.8/3.3	vddshv9	Yes	Dual Voltage LVCMOS	PU/PD	1
		rmii1_crs		2	I									0
		mii0_rxdv		3	I									0
		vin2a_d1		4	I									0
		vin4b_d1		5	I									0
		spi3_sclk		7	IO									0
		gpio5_18		14	IO									
		Driver off		15	I									
Y1	uart3_txd	uart3_txd		0	O	PD	PD	15	1.8/3.3	vddshv9	Yes	Dual Voltage LVCMOS	PU/PD	
		rmii1_rxer		2	I									0
		mii0_rxcclk		3	I									0
		vin2a_d2		4	I									0
		vin4b_d2		5	I									0
		spi3_d1		7	IO									0
		spi4_cs1		8	IO									1
		gpio5_19		14	IO									
Driver off		15	I											
AC12	usb1_dm	usb1_dm		0	IO	OFF	OFF		3.3	vdda33v_usb1		USB3PHY		
AD12	usb1_dp	usb1_dp		0	IO	OFF	OFF		3.3	vdda33v_usb1		USB3PHY		
AB10	usb1_drvvbus	usb1_drvvbus		0	O	PD	PD	15	1.8/3.3	vddshv6	Yes	Dual Voltage LVCMOS	PU/PD	
		timer16		7	IO									
		gpio6_12		14	IO									
		Driver off		15	I									
AF11	usb2_dm	usb2_dm		0	IO				3.3	vdda33v_usb2	No	USB2PHY		
AE11	usb2_dp	usb2_dp		0	IO				3.3	vdda33v_usb2	No	USB2PHY		
AC10	usb2_drvvbus	usb2_drvvbus		0	O	PD	PD	15	1.8/3.3	vddshv6	Yes	Dual Voltage LVCMOS	PU/PD	
		timer15		7	IO									
		gpio6_13		14	IO									
		Driver off		15	I									
AF12	usb_rxn0	usb_rxn0		0	I	OFF	OFF		1.8	vdda_usb1				
AE12	usb_rxp0	usb_rxp0		0	I	OFF	OFF		1.8	vdda_usb1				
AC11	usb_txn0	usb_txn0		0	O				1.8	vdda_usb1				
AD11	usb_txp0	usb_txp0		0	O				1.8	vdda_usb1				

表 4-2. Ball Characteristics⁽¹⁾ (continued)

BALL NUMBER [1]	BALL NAME [2]	SIGNAL NAME [3]	74x [4]	MUXMODE [5]	TYPE [6]	BALL RESET STATE [7]	BALL RESET REL. STATE [8]	BALL RESET REL. MUXMODE [9]	I/O VOLTAGE VALUE [10]	POWER [11]	HYS [12]	BUFFER TYPE [13]	PULL UP/DOWN TYPE [14]	DSIS [15]
H13, H14, J17, J18, L7, L8, N10, N13, P11, P12, P13, R11, R16, R19, T13, T16, T19, U13, U16, U8, U9, V16, V8	vdd	vdd			PWR									
AA12	vdda33v_usb1	vdda33v_usb1			PWR									
Y12	vdda33v_usb2	vdda33v_usb2			PWR									
M14	vdda_abe_per	vdda_abe_per			PWR									
P16	vdda_ddr	vdda_ddr			PWR									
N11	vdda_debug	vdda_debug			PWR									
N12	vdda_dsp_eve	vdda_dsp_eve			PWR									
P15	vdda_gmac_core	vdda_gmac_core			PWR									
R14	vdda_gpu	vdda_gpu			PWR									
Y17	vdda_hdmi	vdda_hdmi			PWR									
R17	vdda_iva	vdda_iva			PWR									
N16	vdda_mpu	vdda_mpu			PWR									
AD16, AE16	vdda_osc	vdda_osc			PWR									
W14	vdda_pcie	vdda_pcie			PWR									
AA17	vdda_pcie0	vdda_pcie0			PWR									
AA16	vdda_pcie1	vdda_pcie1			PWR									
AB13	vdda_rtc	vdda_rtc			PWR									
V13	vdda_sata	vdda_sata			PWR									
AA13	vdda_usb1	vdda_usb1			PWR									
AB12	vdda_usb2	vdda_usb2			PWR									
W12	vdda_usb3	vdda_usb3			PWR									
P14	vdda_video	vdda_video			PWR									
G18, H17, M8, M9, N8, P8, R8, T8, V21, V22, W17, W18	vdds18v	vdds18v			PWR									
AA18, AA19, W21, Y21	vdds18v_ddr1	vdds18v_ddr1			PWR									
J21, J22, N21, P20, P21	vdds18v_ddr2	vdds18v_ddr2			PWR									
E3, E5, G4, G5, H8, H9	vddshv1	vddshv1			PWR									
N4, N5, P10, R10, R7, T4, T5	vddshv10	vddshv10			PWR									
J8, K8	vddshv11	vddshv11			PWR									

表 4-2. Ball Characteristics⁽¹⁾ (continued)

BALL NUMBER [1]	BALL NAME [2]	SIGNAL NAME [3]	74x [4]	MUXMODE [5]	TYPE [6]	BALL RESET STATE [7]	BALL RESET REL. STATE [8]	BALL RESET REL. MUXMODE [9]	I/O VOLTAGE VALUE [10]	POWER [11]	HYS [12]	BUFFER TYPE [13]	PULL UP/DOWN TYPE [14]	DSIS [15]
B6, D10, E10, H10, H11	vddshv2	vddshv2			PWR									
B23, D16, D22, E16, E22, G15, H15, H16, H18, H19	vddshv3	vddshv3			PWR									
C24	vddshv4	vddshv4			PWR									
V12	vddshv5	vddshv5			PWR									
AD5, AD7, AE7, AF5	vddshv6	vddshv6			PWR									
AB6, AB7	vddshv7	vddshv7			PWR									
W8, Y8	vddshv8	vddshv8			PWR									
U10, W4, W5	vddshv9	vddshv9			PWR									
AA21, AA22, AB21, AB22, AB24, AB25, AC22, AD26, AG20, AG28, AH27, W16, W27	vdds_dds1	vdds_dds1			PWR									
E24, G22, G23, H20, H21, H22, J27, L20, L21, M20, M21, T24, T25	vdds_dds2	vdds_dds2			PWR									
AA7, Y7	vdds_milbp	vdds_milbp			PWR									
J13, K10, K11, K12, K13, L10, L11, L12, M10, M11, M12, M13	vdd_dspeve	vdd_dspeve			PWR									
U11, U12, V10, V11, V14, W10, W11, W13	vdd_gpu	vdd_gpu			PWR									
U18, U19, V18, V19	vdd_iva	vdd_iva			PWR									
K17, K18, L15, L16, L17, L18, L19, M15, M16, M17, M18, N17, N18, P17, P18, R18	vdd_mpu	vdd_mpu			PWR									
AB15	vdd_rtc	vdd_rtc			PWR									
AG8	vin1a_clk0	vin1a_clk0	No	0	I	PD	PD	15	1.8/3.3	vddshv6	Yes	Dual Voltage LVCMOS	PU/PD	0
		vout3_d16 ⁽⁹⁾	No	3	O									
		vout3_fld ⁽⁹⁾	No	4	O									
		gpio2_30	Yes ⁽⁷⁾	14	IO									
		Driver off		15	I									

表 4-2. Ball Characteristics⁽¹⁾ (continued)

BALL NUMBER [1]	BALL NAME [2]	SIGNAL NAME [3]	74x [4]	MUXMODE [5]	TYPE [6]	BALL RESET STATE [7]	BALL RESET REL. STATE [8]	BALL RESET REL. MUXMODE [9]	I/O VOLTAGE VALUE [10]	POWER [11]	HYS [12]	BUFFER TYPE [13]	PULL UP/DOWN TYPE [14]	DSIS [15]		
AE8	vin1a_d0	vin1a_d0	No	0	I	PD	PD	15	1.8/3.3	vddshv6	Yes	Dual Voltage LVCMOS	PU/PD	0		
		vout3_d7 ⁽⁹⁾	No	3	O											
		vout3_d23 ⁽⁹⁾	No	4	O											
		uart8_rxd	No	5	I											1
		ehrpwm1A	No	10	O											
		gpio3_4	Yes ⁽⁷⁾	14	IO											
		Driver off		15	I											
AD8	vin1a_d1	vin1a_d1	No	0	I	PD	PD	15	1.8/3.3	vddshv6	Yes	Dual Voltage LVCMOS	PU/PD	0		
		vout3_d6 ⁽⁹⁾	No	3	O											
		vout3_d22 ⁽⁹⁾	No	4	O											
		uart8_txd	No	5	O											
		ehrpwm1B	No	10	O											
		gpio3_5	Yes ⁽⁷⁾	14	IO											
		Driver off		15	I											
AG3	vin1a_d10	vin1a_d10	No	0	I	PD	PD	15	1.8/3.3	vddshv6	Yes	Dual Voltage LVCMOS	PU/PD	0		
		vin1b_d5	No	1	I										0	
		vout3_d13 ⁽⁹⁾	No	4	O											
		kbd_row4	No	9	I										0	
		gpio3_14	Yes ⁽⁷⁾	14	IO											
		Driver off		15	I											
AG5	vin1a_d11	vin1a_d11	No	0	I	PD	PD	15	1.8/3.3	vddshv6	Yes	Dual Voltage LVCMOS	PU/PD	0		
		vin1b_d4	No	1	I										0	
		vout3_d12 ⁽⁹⁾	No	4	O											
		gpmc_a23	No	5	O											
		kbd_row5	No	9	I										0	
		gpio3_15	Yes ⁽⁷⁾	14	IO											
		Driver off		15	I											
AF2	vin1a_d12	vin1a_d12	No	0	I	PD	PD	15	1.8/3.3	vddshv6	Yes	Dual Voltage LVCMOS	PU/PD	0		
		vin1b_d3	No	1	I										0	
		usb3_ulpi_d7	No	2	IO										0	
		vout3_d11 ⁽⁹⁾	No	4	O											
		gpmc_a24	No	5	O											
		kbd_row6	No	9	I										0	
		gpio3_16	Yes ⁽⁷⁾	14	IO											
		Driver off		15	I											

表 4-2. Ball Characteristics⁽¹⁾ (continued)

BALL NUMBER [1]	BALL NAME [2]	SIGNAL NAME [3]	74x [4]	MUXMODE [5]	TYPE [6]	BALL RESET STATE [7]	BALL RESET REL. STATE [8]	BALL RESET REL. MUXMODE [9]	I/O VOLTAGE VALUE [10]	POWER [11]	HYS [12]	BUFFER TYPE [13]	PULL UP/DOWN TYPE [14]	DSIS [15]
AF6	vin1a_d13	vin1a_d13	No	0	I	PD	PD	15	1.8/3.3	vddshv6	Yes	Dual Voltage LVCMOS	PU/PD	0
		vin1b_d2	No	1	I									0
		usb3_ulpi_d6	No	2	IO									0
		vout3_d10 ⁽⁹⁾	No	4	O									
		gpmc_a25	No	5	O									
		kbd_row7	No	9	I									0
		gpio3_17	Yes ⁽⁷⁾	14	IO									
		Driver off		15	I									
AF3	vin1a_d14	vin1a_d14	No	0	I	PD	PD	15	1.8/3.3	vddshv6	Yes	Dual Voltage LVCMOS	PU/PD	0
		vin1b_d1	No	1	I									0
		usb3_ulpi_d5	No	2	IO									0
		vout3_d9 ⁽⁹⁾	No	4	O									
		gpmc_a26	No	5	O									
		kbd_row8	No	9	I									0
		gpio3_18	Yes ⁽⁷⁾	14	IO									
		Driver off		15	I									
AF4	vin1a_d15	vin1a_d15	No	0	I	PD	PD	15	1.8/3.3	vddshv6	Yes	Dual Voltage LVCMOS	PU/PD	0
		vin1b_d0	No	1	I									0
		usb3_ulpi_d4	No	2	IO									0
		vout3_d8 ⁽⁹⁾	No	4	O									
		gpmc_a27	No	5	O									
		kbd_col0	No	9	O									
		gpio3_19	Yes ⁽⁷⁾	14	IO									
		Driver off		15	I									
AF1	vin1a_d16	vin1a_d16	No	0	I	PD	PD	15	1.8/3.3	vddshv6	Yes	Dual Voltage LVCMOS	PU/PD	0
		vin1b_d7	No	1	I									0
		usb3_ulpi_d3	No	2	IO									0
		vout3_d7 ⁽⁹⁾	No	4	O									
		vin3a_d0	No	6	I									0
		kbd_col1	No	9	O									
		gpio3_20	Yes ⁽⁷⁾	14	IO									
		Driver off		15	I									

表 4-2. Ball Characteristics⁽¹⁾ (continued)

BALL NUMBER [1]	BALL NAME [2]	SIGNAL NAME [3]	74x [4]	MUXMODE [5]	TYPE [6]	BALL RESET STATE [7]	BALL RESET REL. STATE [8]	BALL RESET REL. MUXMODE [9]	I/O VOLTAGE VALUE [10]	POWER [11]	HYS [12]	BUFFER TYPE [13]	PULL UP/DOWN TYPE [14]	DSIS [15]
AE3	vin1a_d17	vin1a_d17	No	0	I	PD	PD	15	1.8/3.3	vddshv6	Yes	Dual Voltage LVCMOS	PU/PD	0
		vin1b_d6	No	1	I									0
		usb3_ulpi_d2	No	2	IO									0
		vout3_d6 ⁽⁹⁾	No	4	O									
		vin3a_d1	No	6	I									0
		kbd_col2	No	9	O									
		gpio3_21	Yes ⁽⁷⁾	14	IO									
		Driver off		15	I									
AE5	vin1a_d18	vin1a_d18	No	0	I	PD	PD	15	1.8/3.3	vddshv6	Yes	Dual Voltage LVCMOS	PU/PD	0
		vin1b_d5	No	1	I									0
		usb3_ulpi_d1	No	2	IO									0
		vout3_d5 ⁽⁹⁾	No	4	O									
		vin3a_d2	No	6	I									0
		kbd_col3	No	9	O									
		gpio3_22	Yes ⁽⁷⁾	14	IO									
		Driver off		15	I									
AE1	vin1a_d19	vin1a_d19	No	0	I	PD	PD	15	1.8/3.3	vddshv6	Yes	Dual Voltage LVCMOS	PU/PD	0
		vin1b_d4	No	1	I									0
		usb3_ulpi_d0	No	2	IO									0
		vout3_d4 ⁽⁹⁾	No	4	O									
		vin3a_d3	No	6	I									0
		kbd_col4	No	9	O									
		gpio3_23	Yes ⁽⁷⁾	14	IO									
		Driver off		15	I									
AG7	vin1a_d2	vin1a_d2	No	0	I	PD	PD	15	1.8/3.3	vddshv6	Yes	Dual Voltage LVCMOS	PU/PD	0
		vout3_d5 ⁽⁹⁾	No	3	O									
		vout3_d21 ⁽⁹⁾	No	4	O									
		uart8_ctsn	No	5	I									1
		ehrpwm1_tripzone_input	No	10	IO									0
		gpio3_6	Yes ⁽⁷⁾	14	IO									
		Driver off		15	I									

表 4-2. Ball Characteristics⁽¹⁾ (continued)

BALL NUMBER [1]	BALL NAME [2]	SIGNAL NAME [3]	74x [4]	MUXMODE [5]	TYPE [6]	BALL RESET STATE [7]	BALL RESET REL. STATE [8]	BALL RESET REL. MUXMODE [9]	I/O VOLTAGE VALUE [10]	POWER [11]	HYS [12]	BUFFER TYPE [13]	PULL UP/DOWN TYPE [14]	DSIS [15]
AE2	vin1a_d20	vin1a_d20	No	0	I	PD	PD	15	1.8/3.3	vddshv6	Yes	Dual Voltage LVCMOS	PU/PD	0
		vin1b_d3	No	1	I									0
		usb3_ulpi_nxt	No	2	I									0
		vout3_d3 ⁽⁹⁾	No	4	O									
		vin3a_d4	No	6	I									0
		kbd_col5	No	9	O									
		gpio3_24	Yes ⁽⁷⁾	14	IO									
		Driver off		15	I									
AE6	vin1a_d21	vin1a_d21	No	0	I	PD	PD	15	1.8/3.3	vddshv6	Yes	Dual Voltage LVCMOS	PU/PD	0
		vin1b_d2	No	1	I									0
		usb3_ulpi_dir	No	2	I									0
		vout3_d2 ⁽⁹⁾	No	4	O									
		vin3a_d5	No	6	I									0
		kbd_col6	No	9	O									
		gpio3_25	Yes ⁽⁷⁾	14	IO									
		Driver off		15	I									
AD2	vin1a_d22	vin1a_d22	No	0	I	PD	PD	15	1.8/3.3	vddshv6	Yes	Dual Voltage LVCMOS	PU/PD	0
		vin1b_d1	No	1	I									0
		usb3_ulpi_stp	No	2	O									
		vout3_d1 ⁽⁹⁾	No	4	O									
		vin3a_d6	No	6	I									0
		kbd_col7	No	9	O									
		gpio3_26	Yes ⁽⁷⁾	14	IO									
		Driver off		15	I									
AD3	vin1a_d23	vin1a_d23	No	0	I	PD	PD	15	1.8/3.3	vddshv6	Yes	Dual Voltage LVCMOS	PU/PD	0
		vin1b_d0	No	1	I									0
		usb3_ulpi_clk	No	2	I									0
		vout3_d0 ⁽⁹⁾	No	4	O									
		vin3a_d7	No	6	I									0
		kbd_col8	No	9	O									
		gpio3_27	Yes ⁽⁷⁾	14	IO									
		Driver off		15	I									

表 4-2. Ball Characteristics⁽¹⁾ (continued)

BALL NUMBER [1]	BALL NAME [2]	SIGNAL NAME [3]	74x [4]	MUXMODE [5]	TYPE [6]	BALL RESET STATE [7]	BALL RESET REL. STATE [8]	BALL RESET REL. MUXMODE [9]	I/O VOLTAGE VALUE [10]	POWER [11]	HYS [12]	BUFFER TYPE [13]	PULL UP/DOWN TYPE [14]	DSIS [15]		
AH6	vin1a_d3	vin1a_d3	No	0	I	PD	PD	15	1.8/3.3	vddshv6	Yes	Dual Voltage LVCMOS	PU/PD	0		
		vout3_d4 ⁽⁹⁾	No	3	O											
		vout3_d20 ⁽⁹⁾	No	4	O											
		uart8_rtsn	No	5	O											
		eCAP1_in_PWM1_out	No	10	IO											0
		gpio3_7	Yes ⁽⁷⁾	14	IO											
		Driver off		15	I											
AH3	vin1a_d4	vin1a_d4	No	0	I	PD	PD	15	1.8/3.3	vddshv6	Yes	Dual Voltage LVCMOS	PU/PD	0		
		vout3_d3 ⁽⁹⁾	No	3	O											
		vout3_d19 ⁽⁹⁾	No	4	O											
		ehrpwm1_synci	No	10	I											0
		gpio3_8	Yes ⁽⁷⁾	14	IO											
		Driver off		15	I											
		AH5	vin1a_d5	vin1a_d5	No	0	I	PD	PD	15	1.8/3.3			vddshv6	Yes	Dual Voltage LVCMOS
vout3_d2 ⁽⁹⁾	No			3	O											
vout3_d18 ⁽⁹⁾	No			4	O											
ehrpwm1_synco	No			10	O											
gpio3_9	Yes ⁽⁷⁾			14	IO											
Driver off				15	I											
AG6	vin1a_d6			vin1a_d6	No	0	I	PD	PD	15	1.8/3.3	vddshv6	Yes	Dual Voltage LVCMOS	PU/PD	
		vout3_d1 ⁽⁹⁾	No	3	O											
		vout3_d17 ⁽⁹⁾	No	4	O											
		eQEP2A_in	No	10	I											0
		gpio3_10	Yes ⁽⁷⁾	14	IO											
		Driver off		15	I											
		AH4	vin1a_d7	vin1a_d7	No	0	I	PD	PD	15	1.8/3.3	vddshv6	Yes			Dual Voltage LVCMOS
vout3_d0 ⁽⁹⁾	No			3	O											
vout3_d16 ⁽⁹⁾	No			4	O											
eQEP2B_in	No			10	I									0		
gpio3_11	Yes ⁽⁷⁾			14	IO											
Driver off				15	I											

表 4-2. Ball Characteristics⁽¹⁾ (continued)

BALL NUMBER [1]	BALL NAME [2]	SIGNAL NAME [3]	74x [4]	MUXMODE [5]	TYPE [6]	BALL RESET STATE [7]	BALL RESET REL. STATE [8]	BALL RESET REL. MUXMODE [9]	I/O VOLTAGE VALUE [10]	POWER [11]	HYS [12]	BUFFER TYPE [13]	PULL UP/DOWN TYPE [14]	DSIS [15]
AG4	vin1a_d8	vin1a_d8	No	0	I	PD	PD	15	1.8/3.3	vddshv6	Yes	Dual Voltage LVCMOS	PU/PD	0
		vin1b_d7	No	1	I									0
		vout3_d15 ⁽⁹⁾	No	4	O									
		kbd_row2	No	9	I									0
		eQEP2_index	No	10	IO									0
		gpio3_12	Yes ⁽⁷⁾	14	IO									
		Driver off		15	I									
AG2	vin1a_d9	vin1a_d9	No	0	I	PD	PD	15	1.8/3.3	vddshv6	Yes	Dual Voltage LVCMOS	PU/PD	0
		vin1b_d6	No	1	I									0
		vout3_d14 ⁽⁹⁾	No	4	O									
		kbd_row3	No	9	I									0
		eQEP2_strobe	No	10	IO									0
		gpio3_13	Yes ⁽⁷⁾	14	IO									
		Driver off		15	I									
AD9	vin1a_de0	vin1a_de0	No	0	I	PD	PD	15	1.8/3.3	vddshv6	Yes	Dual Voltage LVCMOS	PU/PD	0
		vin1b_hsync1	No	1	I									0
		vout3_d17 ⁽⁹⁾	No	3	O									
		vout3_de ⁽⁹⁾	No	4	O									
		uart7_rxd	No	5	I									1
		timer16	No	7	IO									
		spi3_sclk	No	8	IO									0
		kbd_row0	No	9	I									0
		eQEP1A_in	No	10	I									0
		gpio3_0	Yes ⁽⁷⁾	14	IO									
Driver off		15	I											
AF9	vin1a_fld0	vin1a_fld0	No	0	I	PD	PD	15	1.8/3.3	vddshv6	Yes	Dual Voltage LVCMOS	PU/PD	0
		vin1b_vsync1	No	1	I									0
		vout3_clk ⁽⁹⁾	No	4	O									
		uart7_txd	No	5	O									
		timer15	No	7	IO									
		spi3_d1	No	8	IO									0
		kbd_row1	No	9	I									0
		eQEP1B_in	No	10	I									0
		gpio3_1	Yes ⁽⁷⁾	14	IO									
		Driver off		15	I									

表 4-2. Ball Characteristics⁽¹⁾ (continued)

BALL NUMBER [1]	BALL NAME [2]	SIGNAL NAME [3]	74x [4]	MUXMODE [5]	TYPE [6]	BALL RESET STATE [7]	BALL RESET REL. STATE [8]	BALL RESET REL. MUXMODE [9]	I/O VOLTAGE VALUE [10]	POWER [11]	HYS [12]	BUFFER TYPE [13]	PULL UP/DOWN TYPE [14]	DSIS [15]
AE9	vin1a_hsync0	vin1a_hsync0	No	0	I	PD	PD	15	1.8/3.3	vddshv6	Yes	Dual Voltage LVCMOS	PU/PD	0
		vin1b_fld1	No	1	I									0
		vout3_hsync ⁽⁹⁾	No	4	O									
		uart7_ctsn	No	5	I									1
		timer14	No	7	IO									
		spi3_d0	No	8	IO									0
		eQEP1_index	No	10	IO									0
		gpio3_2	Yes ⁽⁷⁾	14	IO									
		Driver off		15	I									
AF8	vin1a_vsync0	vin1a_vsync0	No	0	I	PD	PD	15	1.8/3.3	vddshv6	Yes	Dual Voltage LVCMOS	PU/PD	0
		vin1b_de1	No	1	I									0
		vout3_vsync ⁽⁹⁾	No	4	O									
		uart7_rtsn	No	5	O									
		timer13	No	7	IO									1
		spi3_cs0	No	8	IO									0
		eQEP1_strobe	No	10	IO									
		gpio3_3	Yes ⁽⁷⁾	14	IO									
		Driver off		15	I									
AH7	vin1b_clk1	vin1b_clk1	No	0	I	PD	PD	15	1.8/3.3	vddshv6	Yes	Dual Voltage LVCMOS	PU/PD	0
		vin3a_clk0	No	6	I									0
		gpio2_31	Yes ⁽⁷⁾	14	IO									
		Driver off		15	I									
E1	vin2a_clk0	vin2a_clk0		0	I	PD	PD	15	1.8/3.3	vddshv1	Yes	Dual Voltage LVCMOS	PU/PD	
		vout2_fld		4	O									
		emu5		5	O									
		kbd_row0		9	I									0
		eQEP1A_in		10	I									0
		gpio3_28		14	IO									
		Driver off		15	I									

表 4-2. Ball Characteristics⁽¹⁾ (continued)

BALL NUMBER [1]	BALL NAME [2]	SIGNAL NAME [3]	74x [4]	MUXMODE [5]	TYPE [6]	BALL RESET STATE [7]	BALL RESET REL. STATE [8]	BALL RESET REL. MUXMODE [9]	I/O VOLTAGE VALUE [10]	POWER [11]	HYS [12]	BUFFER TYPE [13]	PULL UP/DOWN TYPE [14]	DSIS [15]		
F2	vin2a_d0	vin2a_d0		0	I	PD	PD	15	1.8/3.3	vddshv1	Yes	Dual Voltage LVCMOS	PU/PD	0		
		vout2_d23		4	O											
		emu10		5	O											
		uart9_ctsn		7	I											1
		spi4_d0		8	IO											0
		kbd_row4		9	I											0
		ehrpwm1B		10	O											
		gpio4_1		14	IO											
	Driver off		15	I												
F3	vin2a_d1	vin2a_d1		0	I	PD	PD	15	1.8/3.3	vddshv1	Yes	Dual Voltage LVCMOS	PU/PD	0		
		vout2_d22		4	O											
		emu11		5	O											
		uart9_rtsn		7	O											
		spi4_cs0		8	IO											1
		kbd_row5		9	I											0
		ehrpwm1_tripzone_input		10	IO											0
		gpio4_2		14	IO											
	Driver off		15	I												
D3	vin2a_d10	vin2a_d10		0	I	PD	PD	15	1.8/3.3	vddshv1	Yes	Dual Voltage LVCMOS	PU/PD	0		
		mdio_mclk		3	O										1	
		vout2_d13		4	O											
		kbd_col7		9	O											
		ehrpwm2B		10	O											
		gpio4_11		14	IO											
	Driver off		15	I												
F6	vin2a_d11	vin2a_d11		0	I	PD	PD	15	1.8/3.3	vddshv1	Yes	Dual Voltage LVCMOS	PU/PD	0		
		mdio_d		3	IO										1	
		vout2_d12		4	O											
		kbd_row7		9	I											
		ehrpwm2_tripzone_input		10	IO											
		gpio4_12		14	IO											
	Driver off		15	I												

表 4-2. Ball Characteristics⁽¹⁾ (continued)

BALL NUMBER [1]	BALL NAME [2]	SIGNAL NAME [3]	74x [4]	MUXMODE [5]	TYPE [6]	BALL RESET STATE [7]	BALL RESET REL. STATE [8]	BALL RESET REL. MUXMODE [9]	I/O VOLTAGE VALUE [10]	POWER [11]	HYS [12]	BUFFER TYPE [13]	PULL UP/DOWN TYPE [14]	DSIS [15]
D5	vin2a_d12	vin2a_d12		0	I	PD	PD	15	1.8/3.3	vddshv1	Yes	Dual Voltage LVCMOS	PU/PD	0
		rgmii1_txc		3	O									
		vout2_d11		4	O									
		mii1_rxclk		8	I									0
		kbd_col8		9	O									
		eCAP2_in_PWM2_out		10	IO									0
		gpio4_13		14	IO									
Driver off		15	I											
C2	vin2a_d13	vin2a_d13		0	I	PD	PD	15	1.8/3.3	vddshv1	Yes	Dual Voltage LVCMOS	PU/PD	0
		rgmii1_txctl		3	O									
		vout2_d10		4	O									
		mii1_rxdv		8	I									0
		kbd_row8		9	I									0
		eQEP3A_in		10	I									0
		gpio4_14		14	IO									
Driver off		15	I											
C3	vin2a_d14	vin2a_d14		0	I	PD	PD	15	1.8/3.3	vddshv1	Yes	Dual Voltage LVCMOS	PU/PD	0
		rgmii1_txd3		3	O									
		vout2_d9		4	O									
		mii1_txclk		8	I									0
		eQEP3B_in		10	I									0
		gpio4_15		14	IO									
		Driver off		15	I									
C4	vin2a_d15	vin2a_d15		0	I	PD	PD	15	1.8/3.3	vddshv1	Yes	Dual Voltage LVCMOS	PU/PD	0
		rgmii1_txd2		3	O									
		vout2_d8		4	O									
		mii1_txd0		8	O									
		eQEP3_index		10	IO									0
		gpio4_16		14	IO									
		Driver off		15	I									

表 4-2. Ball Characteristics⁽¹⁾ (continued)

BALL NUMBER [1]	BALL NAME [2]	SIGNAL NAME [3]	74x [4]	MUXMODE [5]	TYPE [6]	BALL RESET STATE [7]	BALL RESET REL. STATE [8]	BALL RESET REL. MUXMODE [9]	I/O VOLTAGE VALUE [10]	POWER [11]	HYS [12]	BUFFER TYPE [13]	PULL UP/DOWN TYPE [14]	DSIS [15]
B2	vin2a_d16	vin2a_d16		0	I	PD	PD	15	1.8/3.3	vddshv1	Yes	Dual Voltage LVCMOS	PU/PD	0
		vin2b_d7		2	I									0
		rgmii1_txd1		3	O									
		vout2_d7		4	O									
		vin3a_d8		6	I									0
		mii1_txd1		8	O									
		eQEP3_strobe		10	IO									0
		gpio4_24		14	IO									
		Driver off		15	I									
D6	vin2a_d17	vin2a_d17		0	I	PD	PD	15	1.8/3.3	vddshv1	Yes	Dual Voltage LVCMOS	PU/PD	0
		vin2b_d6		2	I									0
		rgmii1_txd0		3	O									
		vout2_d6		4	O									
		vin3a_d9		6	I									0
		mii1_txd2		8	O									
		ehrpwm3A		10	O									
		gpio4_25		14	IO									
		Driver off		15	I									
C5	vin2a_d18	vin2a_d18		0	I	PD	PD	15	1.8/3.3	vddshv1	Yes	Dual Voltage LVCMOS	PU/PD	0
		vin2b_d5		2	I									0
		rgmii1_rxc		3	I									0
		vout2_d5		4	O									
		vin3a_d10		6	I									0
		mii1_txd3		8	O									
		ehrpwm3B		10	O									
		gpio4_26		14	IO									
		Driver off		15	I									
A3	vin2a_d19	vin2a_d19		0	I	PD	PD	15	1.8/3.3	vddshv1	Yes	Dual Voltage LVCMOS	PU/PD	0
		vin2b_d4		2	I									0
		rgmii1_rxctl		3	I									0
		vout2_d4		4	O									
		vin3a_d11		6	I									0
		mii1_txer		8	O									0
		ehrpwm3_tripzone_input		10	IO									0
		gpio4_27		14	IO									
		Driver off		15	I									

表 4-2. Ball Characteristics⁽¹⁾ (continued)

BALL NUMBER [1]	BALL NAME [2]	SIGNAL NAME [3]	74x [4]	MUXMODE [5]	TYPE [6]	BALL RESET STATE [7]	BALL RESET REL. STATE [8]	BALL RESET REL. MUXMODE [9]	I/O VOLTAGE VALUE [10]	POWER [11]	HYS [12]	BUFFER TYPE [13]	PULL UP/DOWN TYPE [14]	DSIS [15]			
D1	vin2a_d2	vin2a_d2		0	I	PD	PD	15	1.8/3.3	vddshv1	Yes	Dual Voltage LVCMOS	PU/PD	0			
		vout2_d21		4	O												
		emu12		5	O												
		uart10_rxd		8	I											1	
		kbd_row6		9	I											0	
		eCAP1_in_PWM1_out		10	IO											0	
		gpio4_3		14	IO												
		Driver off		15	I												
B3	vin2a_d20	vin2a_d20		0	I	PD	PD	15	1.8/3.3	vddshv1	Yes	Dual Voltage LVCMOS	PU/PD	0			
		vin2b_d3		2	I											0	
		rgmii1_rxd3		3	I											0	
		vout2_d3		4	O												
		vin3a_de0		5	I											0	
		vin3a_d12		6	I											0	
		mii1_xer		8	I											0	
		eCAP3_in_PWM3_out		10	IO												0
		gpio4_28		14	IO												
		Driver off		15	I												
		B4	vin2a_d21	vin2a_d21		0	I	PD	PD	15	1.8/3.3			vddshv1	Yes	Dual Voltage LVCMOS	PU/PD
vin2b_d2				2	I									0			
rgmii1_rxd2				3	I									0			
vout2_d2				4	O												
vin3a_fld0				5	I									0			
vin3a_d13				6	I									0			
mii1_col				8	I									0			
gpio4_29				14	IO												
Driver off				15	I												
B5	vin2a_d22	vin2a_d22		0	I	PD	PD	15	1.8/3.3	vddshv1	Yes	Dual Voltage LVCMOS	PU/PD	0			
		vin2b_d1		2	I											0	
		rgmii1_rxd1		3	I											0	
		vout2_d1		4	O												
		vin3a_hsync0		5	I											0	
		vin3a_d14		6	I											0	
		mii1_crs		8	I											0	
		gpio4_30		14	IO												
		Driver off		15	I												

表 4-2. Ball Characteristics⁽¹⁾ (continued)

BALL NUMBER [1]	BALL NAME [2]	SIGNAL NAME [3]	74x [4]	MUXMODE [5]	TYPE [6]	BALL RESET STATE [7]	BALL RESET REL. STATE [8]	BALL RESET REL. MUXMODE [9]	I/O VOLTAGE VALUE [10]	POWER [11]	HYS [12]	BUFFER TYPE [13]	PULL UP/DOWN TYPE [14]	DSIS [15]
A4	vin2a_d23	vin2a_d23		0	I	PD	PD	15	1.8/3.3	vddshv1	Yes	Dual Voltage LVCMOS	PU/PD	0
		vin2b_d0		2	I									0
		rgmii1_rxd0		3	I									0
		vout2_d0		4	O									
		vin3a_vsync0		5	I									0
		vin3a_d15		6	I									0
		mii1_txen		8	O									
		gpio4_31		14	IO									
Driver off		15	I											
E2	vin2a_d3	vin2a_d3		0	I	PD	PD	15	1.8/3.3	vddshv1	Yes	Dual Voltage LVCMOS	PU/PD	0
		vout2_d20		4	O									
		emu13		5	O									
		uart10_txd		8	O									
		kbd_col0		9	O									
		ehrpwm1_syncl		10	I									0
		gpio4_4		14	IO									
Driver off		15	I											
D2	vin2a_d4	vin2a_d4		0	I	PD	PD	15	1.8/3.3	vddshv1	Yes	Dual Voltage LVCMOS	PU/PD	0
		vout2_d19		4	O									
		emu14		5	O									
		uart10_ctsn		8	I									1
		kbd_col1		9	O									
		ehrpwm1_synco		10	O									
		gpio4_5		14	IO									
Driver off		15	I											
F4	vin2a_d5	vin2a_d5		0	I	PD	PD	15	1.8/3.3	vddshv1	Yes	Dual Voltage LVCMOS	PU/PD	0
		vout2_d18		4	O									
		emu15		5	O									
		uart10_rtsn		8	O									
		kbd_col2		9	O									
		eQEP2A_in		10	I									0
		gpio4_6		14	IO									
Driver off		15	I											

表 4-2. Ball Characteristics⁽¹⁾ (continued)

BALL NUMBER [1]	BALL NAME [2]	SIGNAL NAME [3]	74x [4]	MUXMODE [5]	TYPE [6]	BALL RESET STATE [7]	BALL RESET REL. STATE [8]	BALL RESET REL. MUXMODE [9]	I/O VOLTAGE VALUE [10]	POWER [11]	HYS [12]	BUFFER TYPE [13]	PULL UP/DOWN TYPE [14]	DSIS [15]			
C1	vin2a_d6	vin2a_d6		0	I	PD	PD	15	1.8/3.3	vddshv1	Yes	Dual Voltage LVCMOS	PU/PD	0			
		vout2_d17		4	O												
		emu16		5	O												
		mii1_rxd1		8	I											0	
		kbd_col3		9	O												
		eQEP2B_in		10	I												0
		gpio4_7		14	IO												
Driver off		15	I														
E4	vin2a_d7	vin2a_d7		0	I	PD	PD	15	1.8/3.3	vddshv1	Yes	Dual Voltage LVCMOS	PU/PD	0			
		vout2_d16		4	O												
		emu17		5	O												
		mii1_rxd2		8	I											0	
		kbd_col4		9	O												
		eQEP2_index		10	IO												0
		gpio4_8		14	IO												
Driver off		15	I														
F5	vin2a_d8	vin2a_d8		0	I	PD	PD	15	1.8/3.3	vddshv1	Yes	Dual Voltage LVCMOS	PU/PD	0			
		vout2_d15		4	O												
		emu18		5	O												
		mii1_rxd3		8	I											0	
		kbd_col5		9	O												
		eQEP2_strobe		10	IO												0
		gpio4_9		14	IO												
Driver off		15	I														
E6	vin2a_d9	vin2a_d9		0	I	PD	PD	15	1.8/3.3	vddshv1	Yes	Dual Voltage LVCMOS	PU/PD	0			
		vout2_d14		4	O												
		emu19		5	O												
		mii1_rxd0		8	I											0	
		kbd_col6		9	O												
		ehrpwm2A		10	O												
		gpio4_10		14	IO												
Driver off		15	I														

表 4-2. Ball Characteristics⁽¹⁾ (continued)

BALL NUMBER [1]	BALL NAME [2]	SIGNAL NAME [3]	74x [4]	MUXMODE [5]	TYPE [6]	BALL RESET STATE [7]	BALL RESET REL. STATE [8]	BALL RESET REL. MUXMODE [9]	I/O VOLTAGE VALUE [10]	POWER [11]	HYS [12]	BUFFER TYPE [13]	PULL UP/DOWN TYPE [14]	DSIS [15]
G2	vin2a_de0	vin2a_de0		0	I	PD	PD	15	1.8/3.3	vddshv1	Yes	Dual Voltage LVCMOS	PU/PD	
		vin2a_fld0		1	I									
		vin2b_fld1		2	I									
		vin2b_de1		3	I									
		vout2_de		4	O									
		emu6		5	O									
		kbd_row1		9	I									
		eQEP1B_in		10	I									
		gpio3_29		14	IO									
Driver off		15	I											
H7	vin2a_fld0	vin2a_fld0		0	I	PD	PD	15	1.8/3.3	vddshv1	Yes	Dual Voltage LVCMOS	PU/PD	
		vin2b_clk1		2	I									
		vout2_clk		4	O									
		emu7		5	O									
		eQEP1_index		10	IO									
		gpio3_30		14	IO									
Driver off		15	I											
G1	vin2a_hsync0	vin2a_hsync0		0	I	PD	PD	15	1.8/3.3	vddshv1	Yes	Dual Voltage LVCMOS	PU/PD	
		vin2b_hsync1		3	I									
		vout2_hsync		4	O									
		emu8		5	O									
		uart9_rxd		7	I									
		spi4_sclk		8	IO									
		kbd_row2		9	I									
		eQEP1_strobe		10	IO									
		gpio3_31		14	IO									
Driver off		15	I											
G6	vin2a_vsync0	vin2a_vsync0		0	I	PD	PD	15	1.8/3.3	vddshv1	Yes	Dual Voltage LVCMOS	PU/PD	
		vin2b_vsync1		3	I									
		vout2_vsync		4	O									
		emu9		5	O									
		uart9_txd		7	O									
		spi4_d1		8	IO									
		kbd_row3		9	I									
		ehrpwm1A		10	O									
		gpio4_0		14	IO									
Driver off		15	I											

表 4-2. Ball Characteristics⁽¹⁾ (continued)

BALL NUMBER [1]	BALL NAME [2]	SIGNAL NAME [3]	74x [4]	MUXMODE [5]	TYPE [6]	BALL RESET STATE [7]	BALL RESET REL. STATE [8]	BALL RESET REL. MUXMODE [9]	I/O VOLTAGE VALUE [10]	POWER [11]	HYS [12]	BUFFER TYPE [13]	PULL UP/DOWN TYPE [14]	DSIS [15]
D11	vout1_clk	vout1_clk		0	O	PD	PD	15	1.8/3.3	vddshv2	Yes	Dual Voltage LVCMOS	PU/PD	
		vin4a_fld0		3	I									0
		vin3a_fld0		4	I									0
		spi3_cs0		8	IO									1
		gpio4_19		14	IO									
		Driver off		15	I									
F11	vout1_d0	vout1_d0		0	O	PD	PD	15	1.8/3.3	vddshv2	Yes	Dual Voltage LVCMOS	PU/PD	
		uart5_rxd		2	I									1
		vin4a_d16		3	I									0
		vin3a_d16		4	I									0
		spi3_cs2		8	IO									1
		gpio8_0		14	IO									
		Driver off		15	I									
G10	vout1_d1	vout1_d1		0	O	PD	PD	15	1.8/3.3	vddshv2	Yes	Dual Voltage LVCMOS	PU/PD	
		uart5_txd		2	O									
		vin4a_d17		3	I									0
		vin3a_d17		4	I									0
		gpio8_1		14	IO									
		Driver off		15	I									
D7	vout1_d10	vout1_d10		0	O	PD	PD	15	1.8/3.3	vddshv2	Yes	Dual Voltage LVCMOS	PU/PD	
		emu3		2	O									
		vin4a_d10		3	I									0
		vin3a_d10		4	I									0
		obs5		5	O									
		obs21		6	O									
		obs_irq2		7	O									
		gpio8_10		14	IO									
		Driver off		15	I									
D8	vout1_d11	vout1_d11		0	O	PD	PD	15	1.8/3.3	vddshv2	Yes	Dual Voltage LVCMOS	PU/PD	
		emu10		2	O									
		vin4a_d11		3	I									0
		vin3a_d11		4	I									0
		obs6		5	O									
		obs22		6	O									
		obs_dmarq2		7	O									
		gpio8_11		14	IO									
		Driver off		15	I									

表 4-2. Ball Characteristics⁽¹⁾ (continued)

BALL NUMBER [1]	BALL NAME [2]	SIGNAL NAME [3]	74x [4]	MUXMODE [5]	TYPE [6]	BALL RESET STATE [7]	BALL RESET REL. STATE [8]	BALL RESET REL. MUXMODE [9]	I/O VOLTAGE VALUE [10]	POWER [11]	HYS [12]	BUFFER TYPE [13]	PULL UP/DOWN TYPE [14]	DSIS [15]	
A5	vout1_d12	vout1_d12		0	O	PD	PD	15	1.8/3.3	vddshv2	Yes	Dual Voltage LVC MOS	PU/PD		
		emu11		2	O										
		vin4a_d12		3	I										0
		vin3a_d12		4	I										0
		obs7		5	O										
		obs23		6	O										
		gpio8_12		14	IO										
		Driver off		15	I										
C6	vout1_d13	vout1_d13		0	O	PD	PD	15	1.8/3.3	vddshv2	Yes	Dual Voltage LVC MOS	PU/PD		
		emu12		2	O										
		vin4a_d13		3	I										0
		vin3a_d13		4	I										0
		obs8		5	O										
		obs24		6	O										
		gpio8_13		14	IO										
		Driver off		15	I										
C8	vout1_d14	vout1_d14		0	O	PD	PD	15	1.8/3.3	vddshv2	Yes	Dual Voltage LVC MOS	PU/PD		
		emu13		2	O										
		vin4a_d14		3	I										0
		vin3a_d14		4	I										0
		obs9		5	O										
		obs25		6	O										
		gpio8_14		14	IO										
		Driver off		15	I										
C7	vout1_d15	vout1_d15		0	O	PD	PD	15	1.8/3.3	vddshv2	Yes	Dual Voltage LVC MOS	PU/PD		
		emu14		2	O										
		vin4a_d15		3	I										0
		vin3a_d15		4	I										0
		obs10		5	O										
		obs26		6	O										
		gpio8_15		14	IO										
		Driver off		15	I										

表 4-2. Ball Characteristics⁽¹⁾ (continued)

BALL NUMBER [1]	BALL NAME [2]	SIGNAL NAME [3]	74x [4]	MUXMODE [5]	TYPE [6]	BALL RESET STATE [7]	BALL RESET REL. STATE [8]	BALL RESET REL. MUXMODE [9]	I/O VOLTAGE VALUE [10]	POWER [11]	HYS [12]	BUFFER TYPE [13]	PULL UP/DOWN TYPE [14]	DSIS [15]
B7	vout1_d16	vout1_d16		0	O	PD	PD	15	1.8/3.3	vddshv2	Yes	Dual Voltage LVCMOS	PU/PD	
		uart7_rxd		2	I									1
		vin4a_d0		3	I									0
		vin3a_d0		4	I									0
		gpio8_16		14	IO									
		Driver off		15	I									
B8	vout1_d17	vout1_d17		0	O	PD	PD	15	1.8/3.3	vddshv2	Yes	Dual Voltage LVCMOS	PU/PD	
		uart7_txd		2	O									
		vin4a_d1		3	I									0
		vin3a_d1		4	I									0
		gpio8_17		14	IO									
		Driver off		15	I									
A7	vout1_d18	vout1_d18		0	O	PD	PD	15	1.8/3.3	vddshv2	Yes	Dual Voltage LVCMOS	PU/PD	
		emu4		2	O									
		vin4a_d2		3	I									0
		vin3a_d2		4	I									0
		obs11		5	O									
		obs27		6	O									
		gpio8_18		14	IO									
		Driver off		15	I									
A8	vout1_d19	vout1_d19		0	O	PD	PD	15	1.8/3.3	vddshv2	Yes	Dual Voltage LVCMOS	PU/PD	
		emu15		2	O									
		vin4a_d3		3	I									0
		vin3a_d3		4	I									0
		obs12		5	O									
		obs28		6	O									
		gpio8_19		14	IO									
		Driver off		15	I									
F10	vout1_d2	vout1_d2		0	O	PD	PD	15	1.8/3.3	vddshv2	Yes	Dual Voltage LVCMOS	PU/PD	
		emu2		2	O									
		vin4a_d18		3	I									0
		vin3a_d18		4	I									0
		obs0		5	O									
		obs16		6	O									
		obs_irq1		7	O									
		gpio8_2		14	IO									
		Driver off		15	I									

表 4-2. Ball Characteristics⁽¹⁾ (continued)

BALL NUMBER [1]	BALL NAME [2]	SIGNAL NAME [3]	74x [4]	MUXMODE [5]	TYPE [6]	BALL RESET STATE [7]	BALL RESET REL. STATE [8]	BALL RESET REL. MUXMODE [9]	I/O VOLTAGE VALUE [10]	POWER [11]	HYS [12]	BUFFER TYPE [13]	PULL UP/DOWN TYPE [14]	DSIS [15]		
C9	vout1_d20	vout1_d20		0	O	PD	PD	15	1.8/3.3	vddshv2	Yes	Dual Voltage LVCMOS	PU/PD			
		emu16		2	O											
		vin4a_d4		3	I										0	
		vin3a_d4		4	I										0	
		obs13		5	O											
		obs29		6	O											
		gpio8_20		14	IO											
		Driver off		15	I											
A9	vout1_d21	vout1_d21		0	O	PD	PD	15	1.8/3.3	vddshv2	Yes	Dual Voltage LVCMOS	PU/PD			
		emu17		2	O											
		vin4a_d5		3	I										0	
		vin3a_d5		4	I										0	
		obs14		5	O											
		obs30		6	O											
		gpio8_21		14	IO											
		Driver off		15	I											
B9	vout1_d22	vout1_d22		0	O	PD	PD	15	1.8/3.3	vddshv2	Yes	Dual Voltage LVCMOS	PU/PD			
		emu18		2	O											
		vin4a_d6		3	I										0	
		vin3a_d6		4	I										0	
		obs15		5	O											
		obs31		6	O											
		gpio8_22		14	IO											
		Driver off		15	I											
A10	vout1_d23	vout1_d23		0	O	PD	PD	15	1.8/3.3	vddshv2	Yes	Dual Voltage LVCMOS	PU/PD			
		emu19		2	O											
		vin4a_d7		3	I										0	
		vin3a_d7		4	I										0	
		spi3_cs3		8	IO										1	
		gpio8_23		14	IO											
		Driver off		15	I											

表 4-2. Ball Characteristics⁽¹⁾ (continued)

BALL NUMBER [1]	BALL NAME [2]	SIGNAL NAME [3]	74x [4]	MUXMODE [5]	TYPE [6]	BALL RESET STATE [7]	BALL RESET REL. STATE [8]	BALL RESET REL. MUXMODE [9]	I/O VOLTAGE VALUE [10]	POWER [11]	HYS [12]	BUFFER TYPE [13]	PULL UP/DOWN TYPE [14]	DSIS [15]
G11	vout1_d3	vout1_d3		0	O	PD	PD	15	1.8/3.3	vddshv2	Yes	Dual Voltage LVCMOS	PU/PD	
		emu5		2	O									
		vin4a_d19		3	I									0
		vin3a_d19		4	I									0
		obs1		5	O									
		obs17		6	O									
		obs_dmarq1		7	O									
		gpio8_3		14	IO									
Driver off		15	I											
E9	vout1_d4	vout1_d4		0	O	PD	PD	15	1.8/3.3	vddshv2	Yes	Dual Voltage LVCMOS	PU/PD	
		emu6		2	O									
		vin4a_d20		3	I									0
		vin3a_d20		4	I									0
		obs2		5	O									
		obs18		6	O									
		gpio8_4		14	IO									
		Driver off		15	I									
F9	vout1_d5	vout1_d5		0	O	PD	PD	15	1.8/3.3	vddshv2	Yes	Dual Voltage LVCMOS	PU/PD	
		emu7		2	O									
		vin4a_d21		3	I									0
		vin3a_d21		4	I									0
		obs3		5	O									
		obs19		6	O									
		gpio8_5		14	IO									
		Driver off		15	I									
F8	vout1_d6	vout1_d6		0	O	PD	PD	15	1.8/3.3	vddshv2	Yes	Dual Voltage LVCMOS	PU/PD	
		emu8		2	O									
		vin4a_d22		3	I									0
		vin3a_d22		4	I									0
		obs4		5	O									
		obs20		6	O									
		gpio8_6		14	IO									
		Driver off		15	I									

表 4-2. Ball Characteristics⁽¹⁾ (continued)

BALL NUMBER [1]	BALL NAME [2]	SIGNAL NAME [3]	74x [4]	MUXMODE [5]	TYPE [6]	BALL RESET STATE [7]	BALL RESET REL. STATE [8]	BALL RESET REL. MUXMODE [9]	I/O VOLTAGE VALUE [10]	POWER [11]	HYS [12]	BUFFER TYPE [13]	PULL UP/DOWN TYPE [14]	DSIS [15]	
E7	vout1_d7	vout1_d7		0	O	PD	PD	15	1.8/3.3	vddshv2	Yes	Dual Voltage LVCMOS	PU/PD		
		emu9		2	O										
		vin4a_d23		3	I										0
		vin3a_d23		4	I										0
		gpio8_7		14	IO										
		Driver off		15	I										
E8	vout1_d8	vout1_d8		0	O	PD	PD	15	1.8/3.3	vddshv2	Yes	Dual Voltage LVCMOS	PU/PD		
		uart6_rxd		2	I										1
		vin4a_d8		3	I										0
		vin3a_d8		4	I										0
		gpio8_8		14	IO										
		Driver off		15	I										
D9	vout1_d9	vout1_d9		0	O	PD	PD	15	1.8/3.3	vddshv2	Yes	Dual Voltage LVCMOS	PU/PD		
		uart6_txd		2	O										
		vin4a_d9		3	I										0
		vin3a_d9		4	I										0
		gpio8_9		14	IO										
		Driver off		15	I										
B10	vout1_de	vout1_de		0	O	PD	PD	15	1.8/3.3	vddshv2	Yes	Dual Voltage LVCMOS	PU/PD		
		vin4a_de0		3	I										0
		vin3a_de0		4	I										0
		spi3_d1		8	IO										0
		gpio4_20		14	IO										
		Driver off		15	I										
B11	vout1_fid	vout1_fid		0	O	PD	PD	15	1.8/3.3	vddshv2	Yes	Dual Voltage LVCMOS	PU/PD		
		vin4a_clk0		3	I										0
		vin3a_clk0		4	I										0
		spi3_cs1		8	IO										1
		gpio4_21		14	IO										
		Driver off		15	I										
C11	vout1_hsync	vout1_hsync		0	O	PD	PD	15	1.8/3.3	vddshv2	Yes	Dual Voltage LVCMOS	PU/PD		
		vin4a_hsync0		3	I										0
		vin3a_hsync0		4	I										0
		spi3_d0		8	IO										0
		gpio4_22		14	IO										
		Driver off		15	I										

表 4-2. Ball Characteristics⁽¹⁾ (continued)

BALL NUMBER [1]	BALL NAME [2]	SIGNAL NAME [3]	74x [4]	MUXMODE [5]	TYPE [6]	BALL RESET STATE [7]	BALL RESET REL. STATE [8]	BALL RESET REL. MUXMODE [9]	I/O VOLTAGE VALUE [10]	POWER [11]	HYS [12]	BUFFER TYPE [13]	PULL UP/DOWN TYPE [14]	DSIS [15]
E11	vout1_vsync	vout1_vsync		0	O	PD	PD	15	1.8/3.3	vddshv2	Yes	Dual Voltage LVCMOS	PU/PD	
		vin4a_vsync0		3	I									0
		vin3a_vsync0		4	I									0
		spi3_sclk		8	IO									0
		gpio4_23		14	IO									
		Driver off		15	I									
A1, A14, A2, A23, A28, A6, AA10, AA14, AA15, AA20, AA8, AA9, AB14, AB20, AD1, AD24, AG1, AH1, AH2, AH20, AH28, AH8, B1, D13, D19, E13, E19, F1, F7, G7, G8, G9, H12, J12, J15, J28, K1, K15, K24, K25, K4, K5, L13, L14, M19, N14, N15, N19, N24, N25, P28, R1, R12, R13, R15, R21, T10, T11, T12, T14, T15, T17, T18, T21, U15, U17, U20, U21, V15, V17, W1, W15, W24, W25, W28	vss	vss			GND									
AD19, AE19	vssa_hdmi	vssa_hdmi			GND									
AF15	vssa_osc0	vssa_osc0			GND									
AC14	vssa_osc1	vssa_osc1			GND									
AD13, AE13	vssa_pcie	vssa_pcie			GND									
AE10	vssa_sata	vssa_sata			GND									
AA11, AB11	vssa_usb	vssa_usb			GND									
AD10	vssa_usb3	vssa_usb3			GND									
U14	vssa_video	vssa_video			GND									
AD17	Wakeup0	Wakeup0		0	I	OFF	OFF	15	1.8/3.3	vddshv5	Yes	IHHV1833	PU/PD	
		dcan1_rx		1	I									1
		gpio1_0		14	I									
		Driver off		15	I									
AC17	Wakeup1	Wakeup1		0	I	OFF	OFF	15	1.8/3.3	vddshv5	Yes	IHHV1833	PU/PD	
		dcan2_rx		1	I									1
		gpio1_1		14	I									
		Driver off		15	I									

表 4-2. Ball Characteristics⁽¹⁾ (continued)

BALL NUMBER [1]	BALL NAME [2]	SIGNAL NAME [3]	74x [4]	MUXMODE [5]	TYPE [6]	BALL RESET STATE [7]	BALL RESET REL. STATE [8]	BALL RESET REL. MUXMODE [9]	I/O VOLTAGE VALUE [10]	POWER [11]	HYS [12]	BUFFER TYPE [13]	PULL UP/DOWN TYPE [14]	DSIS [15]
AB16	Wakeup2	Wakeup2		0	I	OFF	OFF	15	1.8/3.3	vddshv5	Yes	IHHV1833	PU/PD	
		sys_nirq2		1	I									
		gpio1_2		14	I									
		Driver off		15	I									
AC16	Wakeup3	Wakeup3		0	I	OFF	OFF	15	1.8/3.3	vddshv5	Yes	IHHV1833	PU/PD	
		sys_nirq1		1	I									
		gpio1_3		14	I									
		Driver off		15	I									
AE15	xi_osc0	xi_osc0		0	I				1.8	vdda_osc	No	LVC MOS Analog		
AC15	xi_osc1	xi_osc1		0	I				1.8	vdda_osc	No	LVC MOS Analog		
AD15	xo_osc0	xo_osc0		0	O				1.8	vdda_osc	No	LVC MOS Analog		
AC13	xo_osc1	xo_osc1		0	A				1.8	vdda_osc	No	LVC MOS Analog		
D18	xref_clk0	xref_clk0		0	I	PD	PD	15	1.8/3.3	vddshv3	Yes	Dual Voltage LVC MOS	PU/PD	
		mcasep2_axr8		1	IO									0
		mcasep1_axr4		2	IO									0
		mcasep1_ahclkx		3	O									
		mcasep5_ahclkx		4	O									
		atl_clk0		5	O									
		vin6a_d0	No	7	I									0
		hdq0		8	IO									1
		clkout2		9	O									
		timer13		10	IO									
		gpio6_17		14	IO									
		Driver off		15	I									
E17	xref_clk1	xref_clk1		0	I	PD	PD	15	1.8/3.3	vddshv3	Yes	Dual Voltage LVC MOS	PU/PD	
		mcasep2_axr9		1	IO									0
		mcasep1_axr5		2	IO									0
		mcasep2_ahclkx		3	O									
		mcasep6_ahclkx		4	O									
		atl_clk1		5	O									
		vin6a_clk0	No	7	I									0
		timer14		10	IO									
		gpio6_18		14	IO									
		Driver off		15	I									

表 4-2. Ball Characteristics⁽¹⁾ (continued)

BALL NUMBER [1]	BALL NAME [2]	SIGNAL NAME [3]	74x [4]	MUXMODE [5]	TYPE [6]	BALL RESET STATE [7]	BALL RESET REL. STATE [8]	BALL RESET REL. MUXMODE [9]	I/O VOLTAGE VALUE [10]	POWER [11]	HYS [12]	BUFFER TYPE [13]	PULL UP/DOWN TYPE [14]	DSIS [15]
B26	xref_clk2	xref_clk2		0	I	PD	PD	15	1.8/3.3	vddshv3	Yes	Dual Voltage LVCMOS	PU/PD	
		mcasp2_axr10		1	IO									0
		mcasp1_axr6		2	IO									0
		mcasp3_ahclkx		3	O									
		mcasp7_ahclkx		4	O									
		atl_clk2		5	O									
		vout2_clk		6	O									
		vin4a_clk0		8	I									0
		timer15		10	IO									
		gpio6_19		14	IO									
		Driver off		15	I									
C23	xref_clk3	xref_clk3		0	I	PD	PD	15	1.8/3.3	vddshv3	Yes	Dual Voltage LVCMOS	PU/PD	
		mcasp2_axr11		1	IO									0
		mcasp1_axr7		2	IO									0
		mcasp4_ahclkx		3	O									
		mcasp8_ahclkx		4	O									
		atl_clk3		5	O									
		vout2_de		6	O									
		hdq0		7	IO									1
		vin4a_de0		8	I									0
		clkout3		9	O									
		timer16		10	IO									
		gpio6_20		14	IO									
		Driver off		15	I									

- (1) NA in this table stands for Not Applicable.
- (2) For more information on recommended operating conditions, see 表 5-4, *Recommended Operating Conditions*.
- (3) The pullup or pulldown block strength is equal to: minimum = 50 μ A, typical = 100 μ A, maximum = 250 μ A.
- (4) The output impedance settings of this IO cell are programmable; by default, the value is DS[1:0] = 10, this means 40 Ω . For more information on DS[1:0] register configuration, see the Device TRM.
- (5) IO drive strength for usb1_dp, usb1_dm, usb2_dp and usb2_dm: minimum 18.3 mA, maximum 89 mA (for a power supply vdda33v_usb1 and vdda33v_usb2 = 3.46 V).
- (6) Minimum PU = 900 Ω , maximum PU = 3.090 k Ω and minimum PD = 14.25 k Ω , maximum PD = 24.8 k Ω .
For more information, see chapter 7 of the USB2.0 specification, in particular section Signaling / Device Speed Identification.
- (7) This function will not be supported on some pin-compatibleroadmap devices. Pin compatibility can be maintained in the future by not using these GPIO signals.
- (8) In PUx / PDy, x and y = 60 to 200 μ A.
The output impedance settings (or drive strengths) of this IO are programmable (34 Ω , 40 Ω , 48 Ω , 60 Ω , 80 Ω) depending on the values of the I[2:0] registers.
- (9) The VOUT3 interface when multiplexed onto balls mapped to the VDDSHV6 supply rail is restricted to operating in 1.8V mode only (VDDSHV6 must be supplied with 1.8V). 3.3V mode is

not supported. This must be considered in the pin mux programming and VDDSHVx supply connections.

- (10) The internal pull resistors for balls K7, M7, J5, K6, J4, J6, H4, H5 are permanently disabled when sysboot15 is set to 1 as described in the section *Sysboot Configuration* of the Device TRM. If internal pull-up/down resistors are desired on these balls then sysboot15 should be set to 0. If gpmc boot mode is used with SYSBOOT15=1 (not recommended) then external pull-downs should be implemented to keep the address bus at logic-0 value during boot since the gpmc ms-address bits are high-z during boot.

4.3 Multiplexing Characteristics

表 4-3 describes the device multiplexing (no characteristics are available in this table).

注: This table doesn't take into account subsystem multiplexing signals. Subsystem multiplexing signals are described in 4.4, *Signal Descriptions*.

注: For more information, see the Control Module / Control Module Functional Description / PAD Functional Multiplexing and Configuration section of the Device TRM.

注: Configuring two pins to the same input signal is not supported as it can yield unexpected results. This can be easily prevented with the proper software configuration. (Hi-Z mode is not an input signal.)

注: When a pad is set into a multiplexing mode which is not defined by pin multiplexing, that pad's behavior is undefined. This should be avoided.

注意

The I/O timings provided in 7, *Timing Requirements and Switching Characteristics* are valid only if signals within a single IOSET are used. The IOSETs are defined in the corresponding tables.

表 4-3. Multiplexing Characteristics

ADDRESS	REGISTER NAME	BALL NUMBER	MUXMODE FIELD SETTINGS (CTRL_CORE_PAD_*[3:0])												
			0	1	2	3	4	5	6	7	8	9	10	14	15
		P25	ddr2_a6												
		Y23	ddr1_d26												
		Y19	ddr1_d21												
		AE15	xi_osc0												

表 4-3. Multiplexing Characteristics (continued)

ADDRESS	REGISTER NAME	BALL NUMBER	MUXMODE FIELD SETTINGS (CTRL_CORE_PAD_*[3:0])															
			0	1	2	3	4	5	6	7	8	9	10	14	15			
		AH24	ddr1_nck															
		AG15	ljcb_clkp															
		AF24	ddr1_d4															
		U25	ddr2_wen															
		F27	ddr2_d5															
		V25	ddr1_ecc_d6															
		M27	ddr2_dqsn3															
		G26	ddr2_d12															
		AG19	hdmi1_data2x															
		AF21	ddr1_a4															
		E27	ddr2_d6															
		F24	ddr2_d3															
		H26	ddr2_d11															
		W23	ddr1_ecc_d3															
		Y27	ddr1_dqsn3															
		AC24	ddr1_d14															
		J24	ddr2_d15															
		R26	ddr2_a1															
		G27	ddr2_dqsn0															
		AF28	ddr1_d11															
		AA23	ddr1_d24															
		AD18	ddr1_a15															
		H23	ddr2_d8															
		AH16	hdmi1_clocky															
		AC20	ddr1_a2															
		AA24	ddr1_d27															
		W19	ddr1_ecc_d2															
		L24	ddr2_d20															
		AG11	pcie_rxn1															
		AG21	ddr1_rst															
		AE28	ddr1_dqsn1															
		AC11	usb_txn0															
		L22	ddr2_d16															
		U28	ddr2_casn															
		K22	ddr2_d22															
		AG25	ddr1_dqsn0															
		W20	ddr1_d17															
		AF14	rtc_iso															
		AA27	ddr1_dqm3															

表 4-3. Multiplexing Characteristics (continued)

ADDRESS	REGISTER NAME	BALL NUMBER	MUXMODE FIELD SETTINGS (CTRL_CORE_PAD_*(3:0))														
			0	1	2	3	4	5	6	7	8	9	10	14	15		
		AF25	ddr1_d0														
		AF23	ddr1_d6														
		AG18	hdmi1_data1x														
		AG10	sata1_txn0														
		AF20	ddr1_rasn														
		V26	ddr1_dqm_etc														
		V20	ddr1_d16														
		G25	ddr2_d1														
		AH13	pcie_rxp0														
		AC18	ddr1_casn														
		AG9	sata1_rxp0														
		AH23	ddr1_csn0														
		AE11	usb2_dp														
		R25	ddr2_a0														
		Y24	ddr1_d28														
		AH15	ljcb_clkn														
		AD20	ddr1_a0														
		AA25	ddr1_d30														
		L23	ddr2_d19														
		AA1	mlbp_dat_p														
		AD14	rtc_osc_xo														
		J25	ddr2_d13														
		AC25	ddr1_d13														
		AB23	ddr1_dqm1														
		U22	ddr2_a15														
		T22	ddr2_a13														
		AH19	hdmi1_data2y														
		M26	ddr2_d31														
		AB27	ddr1_d22														
		AG14	pcie_txn0														
		Y28	ddr1_dqs3														
		J20	ddr2_d23														
		AB19	ddr1_a3														
		AH10	sata1_txp0														
		G28	ddr2_dqs0														
		AG24	ddr1_ck														
		AE24	ddr1_d5														
		AC15	xi_osc1														

表 4-3. Multiplexing Characteristics (continued)

ADDRESS	REGISTER NAME	BALL NUMBER	MUXMODE FIELD SETTINGS (CTRL_CORE_PAD_*[3:0])																	
			0	1	2	3	4	5	6	7	8	9	10	14	15					
		AC21	ddr1_a12																	
		K28	ddr2_dqsn2																	
		AB1	mlbp_clk_p																	
		AF12	usb_rxn0																	
		L28	ddr2_d27																	
		M24	ddr2_d29																	
		AH9	sata1_rxn0																	
		AC26	ddr1_dqm2																	
		AA28	ddr1_d31																	
		H28	ddr2_dqsn1																	
		AD23	ddr1_dqm0																	
		E26	ddr2_d0																	
		AE27	ddr1_dqs1																	
		AF27	ddr1_d9																	
		V24	ddr1_ecc_d5																	
		K23	ddr2_dqm2																	
		K20	ddr2_d17																	
		T28	ddr2_ck																	
		H24	ddr2_d10																	
		AG27	ddr1_d10																	
		R23	ddr2_odt0																	
		U27	ddr2_ba1																	
		AF22	ddr1_a8																	
		AA2	mlbp_dat_n																	
		U23	ddr2_ba0																	
		AH21	ddr1_wen																	
		AE21	ddr1_a7																	
		AC12	usb1_dm																	
		AH12	pcie_txp1																	
		Y20	ddr1_d23																	
		AC27	ddr1_d20																	
		AE23	ddr1_d7																	
		T27	ddr2_nck																	
		AG22	ddr1_cke																	
		AD27	ddr1_dqs2																	
		AH14	pcie_txp0																	
		AH26	ddr1_d3																	
		AD21	ddr1_a10																	
		N28	ddr2_a12																	

表 4-3. Multiplexing Characteristics (continued)

ADDRESS	REGISTER NAME	BALL NUMBER	MUXMODE FIELD SETTINGS (CTRL_CORE_PAD_*(3:0))															
			0	1	2	3	4	5	6	7	8	9	10	14	15			
		Y25	ddr1_ecc_d4															
		AE17	ddr1_a14															
		AH18	hdmi1_data1y															
		AH22	ddr1_a5															
		J26	ddr2_d14															
		W22	ddr1_ecc_d0															
		V23	ddr1_ecc_d1															
		AE12	usb_rxp0															
		AE14	rtc_osc_xi_clk n32															
		AH11	pcie_rxp1															
		AB2	mlbp_clk_n															
		AG23	ddr1_a6															
		H27	ddr2_dqs1															
		AB18	ddr1_ba2															
		AG17	hdmi1_data0x															
		AF26	ddr1_d1															
		H25	ddr2_d9															
		M25	ddr2_d30															
		AD11	usb_txp0															
		AC1	mlbp_sig_p															
		L27	ddr2_d24															
		V27	ddr1_dqs_ecc															
		AF17	ddr1_ba0															
		AE26	ddr1_d12															
		G24	ddr2_dqm1															
		K27	ddr2_dqs2															
		AC19	ddr1_a1															
		AG13	pcie_rxn0															
		L26	ddr2_d25															
		AB28	ddr1_d18															
		N23	ddr2_a10															
		M22	ddr2_dqm3															
		U26	ddr2_ba2															
		Y26	ddr1_ecc_d7															
		P24	ddr2_csn0															
		R22	ddr2_a14															
		AD22	ddr1_a11															
		N20	ddr2_a7															

表 4-3. Multiplexing Characteristics (continued)

ADDRESS	REGISTER NAME	BALL NUMBER	MUXMODE FIELD SETTINGS (CTRL_CORE_PAD_*[3:0])														
			0	1	2	3	4	5	6	7	8	9	10	14	15		
		M23	ddr2_d28														
		AD28	ddr1_dqsn2														
		U24	ddr2_cke														
		P22	ddr2_a5														
		AE18	ddr1_ba1														
		F26	ddr2_d4														
		AE20	ddr1_odt0														
		N22	ddr2_vref0														
		E28	ddr2_d7														
		F25	ddr2_d2														
		AF11	usb2_dm														
		R24	ddr2_rst														
		AD15	xo_osc0														
		R27	ddr2_a3														
		AE22	ddr1_a9														
		Y18	ddr1_vref0														
		AC13	xo_osc1														
		F28	ddr2_dqm0														
		J23	ddr2_d21														
		P26	ddr2_a11														
		M28	ddr2_dqs3														
		AC2	mlbp_sig_n														
		AD12	usb1_dp														
		Y22	ddr1_d25														
		T23	ddr2_rasn														
		AH17	hdmi1_data0y														
		N27	ddr2_a9														
		P23	ddr2_a4														
		AG26	ddr1_d2														
		AH25	ddr1_dqs0														
		AG12	pcie_bxn1														
		AF18	ddr1_a13														
		K21	ddr2_d18														
		AC28	ddr1_d19														
		V28	ddr1_dqsn_ec														
		P27	ddr2_a8														
		AC23	ddr1_d8														
		F22	porz														

表 4-3. Multiplexing Characteristics (continued)

ADDRESS	REGISTER NAME	BALL NUMBER	MUXMODE FIELD SETTINGS (CTRL_CORE_PAD_*[3:0])														
			0	1	2	3	4	5	6	7	8	9	10	14	15		
		L25	ddr2_d26														
		AG16	hdmi1_clockx														
		R28	ddr2_a2														
		AA26	ddr1_d29														
		AD25	ddr1_d15														
0x1400	CTRL_CORE_PAD_GPMC_AD0	M6	gpmc_ad0		vin3a_d0	vout3_d0									gpio1_6	sysboot0	
0x1404	CTRL_CORE_PAD_GPMC_AD1	M2	gpmc_ad1		vin3a_d1	vout3_d1									gpio1_7	sysboot1	
0x1408	CTRL_CORE_PAD_GPMC_AD2	L5	gpmc_ad2		vin3a_d2	vout3_d2									gpio1_8	sysboot2	
0x140C	CTRL_CORE_PAD_GPMC_AD3	M1	gpmc_ad3		vin3a_d3	vout3_d3									gpio1_9	sysboot3	
0x1410	CTRL_CORE_PAD_GPMC_AD4	L6	gpmc_ad4		vin3a_d4	vout3_d4									gpio1_10	sysboot4	
0x1414	CTRL_CORE_PAD_GPMC_AD5	L4	gpmc_ad5		vin3a_d5	vout3_d5									gpio1_11	sysboot5	
0x1418	CTRL_CORE_PAD_GPMC_AD6	L3	gpmc_ad6		vin3a_d6	vout3_d6									gpio1_12	sysboot6	
0x141C	CTRL_CORE_PAD_GPMC_AD7	L2	gpmc_ad7		vin3a_d7	vout3_d7									gpio1_13	sysboot7	
0x1420	CTRL_CORE_PAD_GPMC_AD8	L1	gpmc_ad8		vin3a_d8	vout3_d8									gpio7_18	sysboot8	
0x1424	CTRL_CORE_PAD_GPMC_AD9	K2	gpmc_ad9		vin3a_d9	vout3_d9									gpio7_19	sysboot9	
0x1428	CTRL_CORE_PAD_GPMC_AD10	J1	gpmc_ad10		vin3a_d10	vout3_d10									gpio7_28	sysboot10	
0x142C	CTRL_CORE_PAD_GPMC_AD11	J2	gpmc_ad11		vin3a_d11	vout3_d11									gpio7_29	sysboot11	
0x1430	CTRL_CORE_PAD_GPMC_AD12	H1	gpmc_ad12		vin3a_d12	vout3_d12									gpio1_18	sysboot12	
0x1434	CTRL_CORE_PAD_GPMC_AD13	J3	gpmc_ad13		vin3a_d13	vout3_d13									gpio1_19	sysboot13	
0x1438	CTRL_CORE_PAD_GPMC_AD14	H2	gpmc_ad14		vin3a_d14	vout3_d14									gpio1_20	sysboot14	
0x143C	CTRL_CORE_PAD_GPMC_AD15	H3	gpmc_ad15		vin3a_d15	vout3_d15									gpio1_21	sysboot15	
0x1440	CTRL_CORE_PAD_GPMC_A0	R6	gpmc_a0		vin3a_d16	vout3_d16	vin4a_d0		vin4b_d0	i2c4_scl	uart5_rxd				gpio7_3	Driver off	
0x1444	CTRL_CORE_PAD_GPMC_A1	T9	gpmc_a1		vin3a_d17	vout3_d17	vin4a_d1		vin4b_d1	i2c4_sda	uart5_txd				gpio7_4	Driver off	
0x1448	CTRL_CORE_PAD_GPMC_A2	T6	gpmc_a2		vin3a_d18	vout3_d18	vin4a_d2		vin4b_d2	uart7_rxd	uart5_ctsn				gpio7_5	Driver off	
0x144C	CTRL_CORE_PAD_GPMC_A3	T7	gpmc_a3	qspi1_cs2	vin3a_d19	vout3_d19	vin4a_d3		vin4b_d3	uart7_txd	uart5_rtsn				gpio7_6	Driver off	

表 4-3. Multiplexing Characteristics (continued)

ADDRESS	REGISTER NAME	BALL NUMBER	MUXMODE FIELD SETTINGS (CTRL_CORE_PAD_*[3:0])												
			0	1	2	3	4	5	6	7	8	9	10	14	15
0x1450	CTRL_CORE_PAD_GPMC_A4	P6	gpmc_a4	qspi1_cs3	vin3a_d20	vout3_d20	vin4a_d4		vin4b_d4	i2c5_scl	uart6_rxd			gpio1_26	Driver off
0x1454	CTRL_CORE_PAD_GPMC_A5	R9	gpmc_a5		vin3a_d21	vout3_d21	vin4a_d5		vin4b_d5	i2c5_sda	uart6_txd			gpio1_27	Driver off
0x1458	CTRL_CORE_PAD_GPMC_A6	R5	gpmc_a6		vin3a_d22	vout3_d22	vin4a_d6		vin4b_d6	uart8_rxd	uart6_ctsn			gpio1_28	Driver off
0x145C	CTRL_CORE_PAD_GPMC_A7	P5	gpmc_a7		vin3a_d23	vout3_d23	vin4a_d7		vin4b_d7	uart8_txd	uart6_rtsn			gpio1_29	Driver off
0x1460	CTRL_CORE_PAD_GPMC_A8	N7	gpmc_a8		vin3a_hsync0	vout3_hsync			vin4b_hsync1	timer12	spi4_sclk			gpio1_30	Driver off
0x1464	CTRL_CORE_PAD_GPMC_A9	R4	gpmc_a9		vin3a_vsync0	vout3_vsync			vin4b_vsync1	timer11	spi4_d1			gpio1_31	Driver off
0x1468	CTRL_CORE_PAD_GPMC_A10	N9	gpmc_a10		vin3a_de0	vout3_de			vin4b_clk1	timer10	spi4_d0			gpio2_0	Driver off
0x146C	CTRL_CORE_PAD_GPMC_A11	P9	gpmc_a11		vin3a_fld0	vout3_fld	vin4a_fld0		vin4b_de1	timer9	spi4_cs0			gpio2_1	Driver off
0x1470	CTRL_CORE_PAD_GPMC_A12	P4	gpmc_a12				vin4a_clk0	gpmc_a0	vin4b_fld1	timer8	spi4_cs1	dma_evt1		gpio2_2	Driver off
0x1474	CTRL_CORE_PAD_GPMC_A13	R3	gpmc_a13	qspi1_rtclk			vin4a_hsync0			timer7	spi4_cs2	dma_evt2		gpio2_3	Driver off
0x1478	CTRL_CORE_PAD_GPMC_A14	T2	gpmc_a14	qspi1_d3			vin4a_vsync0			timer6	spi4_cs3			gpio2_4	Driver off
0x147C	CTRL_CORE_PAD_GPMC_A15	U2	gpmc_a15	qspi1_d2			vin4a_d8			timer5				gpio2_5	Driver off
0x1480	CTRL_CORE_PAD_GPMC_A16	U1	gpmc_a16	qspi1_d0			vin4a_d9							gpio2_6	Driver off
0x1484	CTRL_CORE_PAD_GPMC_A17	P3	gpmc_a17	qspi1_d1			vin4a_d10							gpio2_7	Driver off
0x1488	CTRL_CORE_PAD_GPMC_A18	R2	gpmc_a18	qspi1_sclk			vin4a_d11							gpio2_8	Driver off
0x148C	CTRL_CORE_PAD_GPMC_A19	K7	gpmc_a19	mmc2_dat4	gpmc_a13		vin4a_d12		vin3b_d0					gpio2_9	Driver off
0x1490	CTRL_CORE_PAD_GPMC_A20	M7	gpmc_a20	mmc2_dat5	gpmc_a14		vin4a_d13		vin3b_d1					gpio2_10	Driver off
0x1494	CTRL_CORE_PAD_GPMC_A21	J5	gpmc_a21	mmc2_dat6	gpmc_a15		vin4a_d14		vin3b_d2					gpio2_11	Driver off
0x1498	CTRL_CORE_PAD_GPMC_A22	K6	gpmc_a22	mmc2_dat7	gpmc_a16		vin4a_d15		vin3b_d3					gpio2_12	Driver off
0x149C	CTRL_CORE_PAD_GPMC_A23	J7	gpmc_a23	mmc2_clk	gpmc_a17		vin4a_fld0		vin3b_d4					gpio2_13	Driver off
0x14A0	CTRL_CORE_PAD_GPMC_A24	J4	gpmc_a24	mmc2_dat0	gpmc_a18				vin3b_d5					gpio2_14	Driver off
0x14A4	CTRL_CORE_PAD_GPMC_A25	J6	gpmc_a25	mmc2_dat1	gpmc_a19				vin3b_d6					gpio2_15	Driver off
0x14A8	CTRL_CORE_PAD_GPMC_A26	H4	gpmc_a26	mmc2_dat2	gpmc_a20				vin3b_d7					gpio2_16	Driver off
0x14AC	CTRL_CORE_PAD_GPMC_A27	H5	gpmc_a27	mmc2_dat3	gpmc_a21				vin3b_hsync1					gpio2_17	Driver off

表 4-3. Multiplexing Characteristics (continued)

ADDRESS	REGISTER NAME	BALL NUMBER	MUXMODE FIELD SETTINGS (CTRL_CORE_PAD_*[3:0])												
			0	1	2	3	4	5	6	7	8	9	10	14	15
0x14B0	CTRL_CORE_PAD_GPMC_CS1	H6	gpmc_cs1	mmc2_cmd	gpmc_a22		vin4a_de0		vin3b_vsync1					gpio2_18	Driver off
0x14B4	CTRL_CORE_PAD_GPMC_CS0	T1	gpmc_cs0											gpio2_19	Driver off
0x14B8	CTRL_CORE_PAD_GPMC_CS2	P2	gpmc_cs2	qspi1_cs0										gpio2_20	Driver off
0x14BC	CTRL_CORE_PAD_GPMC_CS3	P1	gpmc_cs3	qspi1_cs1	vin3a_clk0	vout3_clk		gpmc_a1						gpio2_21	Driver off
0x14C0	CTRL_CORE_PAD_GPMC_CLK	P7	gpmc_clk	gpmc_cs7	clkout1	gpmc_wait1	vin4a_hsync0	vin4a_de0	vin3b_clk1	timer4	i2c3_scl	dma_evt1		gpio2_22	Driver off
0x14C4	CTRL_CORE_PAD_GPMC_ADV_N_ALE	N1	gpmc_adv_n_ale	gpmc_cs6	clkout2	gpmc_wait1	vin4a_vsync0	gpmc_a2	gpmc_a23	timer3	i2c3_sda	dma_evt2		gpio2_23	Driver off
0x14C8	CTRL_CORE_PAD_GPMC_OEN_REN	M5	gpmc_oen_ren											gpio2_24	Driver off
0x14CC	CTRL_CORE_PAD_GPMC_WEN	M3	gpmc_wen											gpio2_25	Driver off
0x14D0	CTRL_CORE_PAD_GPMC_BEN0	N6	gpmc_ben0	gpmc_cs4		vin1b_hsync1			vin3b_de1	timer2		dma_evt3		gpio2_26	Driver off
0x14D4	CTRL_CORE_PAD_GPMC_BEN1	M4	gpmc_ben1	gpmc_cs5		vin1b_de1	vin3b_clk1	gpmc_a3	vin3b_fld1	timer1		dma_evt4		gpio2_27	Driver off
0x14D8	CTRL_CORE_PAD_GPMC_WAIT0	N2	gpmc_wait0											gpio2_28	Driver off
0x14DC	CTRL_CORE_PAD_VIN1A_CLK0	AG8	vin1a_clk0			vout3_d16	vout3_fld							gpio2_30	Driver off
0x14E0	CTRL_CORE_PAD_VIN1B_CLK1	AH7	vin1b_clk1						vin3a_clk0					gpio2_31	Driver off
0x14E4	CTRL_CORE_PAD_VIN1A_DE0	AD9	vin1a_de0	vin1b_hsync1		vout3_d17	vout3_de	uart7_rxd		timer16	spi3_sclk	kbd_row0	eQEP1A_in	gpio3_0	Driver off
0x14E8	CTRL_CORE_PAD_VIN1A_FLD0	AF9	vin1a_fld0	vin1b_vsync1			vout3_clk	uart7_txd		timer15	spi3_d1	kbd_row1	eQEP1B_in	gpio3_1	Driver off
0x14EC	CTRL_CORE_PAD_VIN1A_HSYNC0	AE9	vin1a_hsync0	vin1b_fld1			vout3_hsync	uart7_ctsn		timer14	spi3_d0		eQEP1_index	gpio3_2	Driver off
0x14F0	CTRL_CORE_PAD_VIN1A_VSYNC0	AF8	vin1a_vsync0	vin1b_de1			vout3_vsync	uart7_rtsn		timer13	spi3_cs0		eQEP1_strobe	gpio3_3	Driver off
0x14F4	CTRL_CORE_PAD_VIN1A_D0	AE8	vin1a_d0			vout3_d7	vout3_d23	uart8_rxd					ehrpwm1A	gpio3_4	Driver off
0x14F8	CTRL_CORE_PAD_VIN1A_D1	AD8	vin1a_d1			vout3_d6	vout3_d22	uart8_txd					ehrpwm1B	gpio3_5	Driver off
0x14FC	CTRL_CORE_PAD_VIN1A_D2	AG7	vin1a_d2			vout3_d5	vout3_d21	uart8_ctsn					ehrpwm1_tripzone_input	gpio3_6	Driver off
0x1500	CTRL_CORE_PAD_VIN1A_D3	AH6	vin1a_d3			vout3_d4	vout3_d20	uart8_rtsn					eCAP1_in_PWM1_out	gpio3_7	Driver off
0x1504	CTRL_CORE_PAD_VIN1A_D4	AH3	vin1a_d4			vout3_d3	vout3_d19						ehrpwm1_syn ci	gpio3_8	Driver off
0x1508	CTRL_CORE_PAD_VIN1A_D5	AH5	vin1a_d5			vout3_d2	vout3_d18						ehrpwm1_syn co	gpio3_9	Driver off
0x150C	CTRL_CORE_PAD_VIN1A_D6	AG6	vin1a_d6			vout3_d1	vout3_d17						eQEP2A_in	gpio3_10	Driver off

表 4-3. Multiplexing Characteristics (continued)

ADDRESS	REGISTER NAME	BALL NUMBER	MUXMODE FIELD SETTINGS (CTRL_CORE_PAD_*[3:0])													
			0	1	2	3	4	5	6	7	8	9	10	14	15	
0x1510	CTRL_CORE_PAD_VIN1A_D7	AH4	vin1a_d7			vout3_d0	vout3_d16							eQEP2B_in	gpio3_11	Driver off
0x1514	CTRL_CORE_PAD_VIN1A_D8	AG4	vin1a_d8	vin1b_d7				vout3_d15					kbd_row2	eQEP2_index	gpio3_12	Driver off
0x1518	CTRL_CORE_PAD_VIN1A_D9	AG2	vin1a_d9	vin1b_d6				vout3_d14					kbd_row3	eQEP2_strobe	gpio3_13	Driver off
0x151C	CTRL_CORE_PAD_VIN1A_D10	AG3	vin1a_d10	vin1b_d5				vout3_d13					kbd_row4		gpio3_14	Driver off
0x1520	CTRL_CORE_PAD_VIN1A_D11	AG5	vin1a_d11	vin1b_d4				vout3_d12	gpmc_a23				kbd_row5		gpio3_15	Driver off
0x1524	CTRL_CORE_PAD_VIN1A_D12	AF2	vin1a_d12	vin1b_d3	usb3_ulpi_d7			vout3_d11	gpmc_a24				kbd_row6		gpio3_16	Driver off
0x1528	CTRL_CORE_PAD_VIN1A_D13	AF6	vin1a_d13	vin1b_d2	usb3_ulpi_d6			vout3_d10	gpmc_a25				kbd_row7		gpio3_17	Driver off
0x152C	CTRL_CORE_PAD_VIN1A_D14	AF3	vin1a_d14	vin1b_d1	usb3_ulpi_d5			vout3_d9	gpmc_a26				kbd_row8		gpio3_18	Driver off
0x1530	CTRL_CORE_PAD_VIN1A_D15	AF4	vin1a_d15	vin1b_d0	usb3_ulpi_d4			vout3_d8	gpmc_a27				kbd_col0		gpio3_19	Driver off
0x1534	CTRL_CORE_PAD_VIN1A_D16	AF1	vin1a_d16	vin1b_d7	usb3_ulpi_d3			vout3_d7		vin3a_d0			kbd_col1		gpio3_20	Driver off
0x1538	CTRL_CORE_PAD_VIN1A_D17	AE3	vin1a_d17	vin1b_d6	usb3_ulpi_d2			vout3_d6		vin3a_d1			kbd_col2		gpio3_21	Driver off
0x153C	CTRL_CORE_PAD_VIN1A_D18	AE5	vin1a_d18	vin1b_d5	usb3_ulpi_d1			vout3_d5		vin3a_d2			kbd_col3		gpio3_22	Driver off
0x1540	CTRL_CORE_PAD_VIN1A_D19	AE1	vin1a_d19	vin1b_d4	usb3_ulpi_d0			vout3_d4		vin3a_d3			kbd_col4		gpio3_23	Driver off
0x1544	CTRL_CORE_PAD_VIN1A_D20	AE2	vin1a_d20	vin1b_d3	usb3_ulpi_nxt			vout3_d3		vin3a_d4			kbd_col5		gpio3_24	Driver off
0x1548	CTRL_CORE_PAD_VIN1A_D21	AE6	vin1a_d21	vin1b_d2	usb3_ulpi_dir			vout3_d2		vin3a_d5			kbd_col6		gpio3_25	Driver off
0x154C	CTRL_CORE_PAD_VIN1A_D22	AD2	vin1a_d22	vin1b_d1	usb3_ulpi_stp			vout3_d1		vin3a_d6			kbd_col7		gpio3_26	Driver off
0x1550	CTRL_CORE_PAD_VIN1A_D23	AD3	vin1a_d23	vin1b_d0	usb3_ulpi_clk			vout3_d0		vin3a_d7			kbd_col8		gpio3_27	Driver off
0x1554	CTRL_CORE_PAD_VIN2A_CLK0	E1	vin2a_clk0					vout2_fld	emu5				kbd_row0	eQEP1A_in	gpio3_28	Driver off
0x1558	CTRL_CORE_PAD_VIN2A_DE0	G2	vin2a_de0	vin2a_fld0	vin2b_fld1	vin2b_de1	vout2_de	emu6					kbd_row1	eQEP1B_in	gpio3_29	Driver off
0x155C	CTRL_CORE_PAD_VIN2A_FLD0	H7	vin2a_fld0		vin2b_clk1		vout2_clk	emu7						eQEP1_index	gpio3_30	Driver off
0x1560	CTRL_CORE_PAD_VIN2A_HSYNCO	G1	vin2a_hsync0			vin2b_hsync1	vout2_hsync	emu8			uart9_rxd	spi4_sclk	kbd_row2	eQEP1_strobe	gpio3_31	Driver off
0x1564	CTRL_CORE_PAD_VIN2A_VSYNCO	G6	vin2a_vsync0			vin2b_vsync1	vout2_vsync	emu9			uart9_txd	spi4_d1	kbd_row3	ehrpwm1A	gpio4_0	Driver off
0x1568	CTRL_CORE_PAD_VIN2A_D0	F2	vin2a_d0				vout2_d23	emu10			uart9_ctsn	spi4_d0	kbd_row4	ehrpwm1B	gpio4_1	Driver off
0x156C	CTRL_CORE_PAD_VIN2A_D1	F3	vin2a_d1				vout2_d22	emu11			uart9_rtsn	spi4_cs0	kbd_row5	ehrpwm1_trip_zone_input	gpio4_2	Driver off

表 4-3. Multiplexing Characteristics (continued)

ADDRESS	REGISTER NAME	BALL NUMBER	MUXMODE FIELD SETTINGS (CTRL_CORE_PAD_*(3:0))														
			0	1	2	3	4	5	6	7	8	9	10	14	15		
0x1570	CTRL_CORE_PAD_VIN2A_D2	D1	vin2a_d2					vout2_d21	emu12				uart10_rxd	kbd_row6	eCAP1_in_PWM1_out	gpio4_3	Driver off
0x1574	CTRL_CORE_PAD_VIN2A_D3	E2	vin2a_d3					vout2_d20	emu13				uart10_txd	kbd_col0	ehrpwm1_syn ci	gpio4_4	Driver off
0x1578	CTRL_CORE_PAD_VIN2A_D4	D2	vin2a_d4					vout2_d19	emu14				uart10_ctsn	kbd_col1	ehrpwm1_syn co	gpio4_5	Driver off
0x157C	CTRL_CORE_PAD_VIN2A_D5	F4	vin2a_d5					vout2_d18	emu15				uart10_rtsn	kbd_col2	eQEP2A_in	gpio4_6	Driver off
0x1580	CTRL_CORE_PAD_VIN2A_D6	C1	vin2a_d6					vout2_d17	emu16				mii1_rxd1	kbd_col3	eQEP2B_in	gpio4_7	Driver off
0x1584	CTRL_CORE_PAD_VIN2A_D7	E4	vin2a_d7					vout2_d16	emu17				mii1_rxd2	kbd_col4	eQEP2_index	gpio4_8	Driver off
0x1588	CTRL_CORE_PAD_VIN2A_D8	F5	vin2a_d8					vout2_d15	emu18				mii1_rxd3	kbd_col5	eQEP2_strobe	gpio4_9	Driver off
0x158C	CTRL_CORE_PAD_VIN2A_D9	E6	vin2a_d9					vout2_d14	emu19				mii1_rxd0	kbd_col6	ehrpwm2A	gpio4_10	Driver off
0x1590	CTRL_CORE_PAD_VIN2A_D10	D3	vin2a_d10				mdio_mclk	vout2_d13						kbd_col7	ehrpwm2B	gpio4_11	Driver off
0x1594	CTRL_CORE_PAD_VIN2A_D11	F6	vin2a_d11				mdio_d	vout2_d12						kbd_row7	ehrpwm2_trip zone_input	gpio4_12	Driver off
0x1598	CTRL_CORE_PAD_VIN2A_D12	D5	vin2a_d12				rgmii1_txc	vout2_d11					mii1_rxclk	kbd_col8	eCAP2_in_PWM2_out	gpio4_13	Driver off
0x159C	CTRL_CORE_PAD_VIN2A_D13	C2	vin2a_d13				rgmii1_txctl	vout2_d10					mii1_rxdv	kbd_row8	eQEP3A_in	gpio4_14	Driver off
0x15A0	CTRL_CORE_PAD_VIN2A_D14	C3	vin2a_d14				rgmii1_txd3	vout2_d9					mii1_txclk		eQEP3B_in	gpio4_15	Driver off
0x15A4	CTRL_CORE_PAD_VIN2A_D15	C4	vin2a_d15				rgmii1_txd2	vout2_d8					mii1_txd0		eQEP3_index	gpio4_16	Driver off
0x15A8	CTRL_CORE_PAD_VIN2A_D16	B2	vin2a_d16		vin2b_d7		rgmii1_txd1	vout2_d7			vin3a_d8		mii1_txd1		eQEP3_strobe	gpio4_24	Driver off
0x15AC	CTRL_CORE_PAD_VIN2A_D17	D6	vin2a_d17		vin2b_d6		rgmii1_txd0	vout2_d6			vin3a_d9		mii1_txd2		ehrpwm3A	gpio4_25	Driver off
0x15B0	CTRL_CORE_PAD_VIN2A_D18	C5	vin2a_d18		vin2b_d5		rgmii1_rxc	vout2_d5			vin3a_d10		mii1_txd3		ehrpwm3B	gpio4_26	Driver off
0x15B4	CTRL_CORE_PAD_VIN2A_D19	A3	vin2a_d19		vin2b_d4		rgmii1_rxtcl	vout2_d4			vin3a_d11		mii1_txer		ehrpwm3_trip zone_input	gpio4_27	Driver off
0x15B8	CTRL_CORE_PAD_VIN2A_D20	B3	vin2a_d20		vin2b_d3		rgmii1_rxd3	vout2_d3	vin3a_de0		vin3a_d12		mii1_rxer		eCAP3_in_PWM3_out	gpio4_28	Driver off
0x15BC	CTRL_CORE_PAD_VIN2A_D21	B4	vin2a_d21		vin2b_d2		rgmii1_rxd2	vout2_d2	vin3a_fld0		vin3a_d13		mii1_col			gpio4_29	Driver off
0x15C0	CTRL_CORE_PAD_VIN2A_D22	B5	vin2a_d22		vin2b_d1		rgmii1_rxd1	vout2_d1	vin3a_hsync0		vin3a_d14		mii1_crs			gpio4_30	Driver off
0x15C4	CTRL_CORE_PAD_VIN2A_D23	A4	vin2a_d23		vin2b_d0		rgmii1_rxd0	vout2_d0	vin3a_vsync0		vin3a_d15		mii1_txen			gpio4_31	Driver off
0x15C8	CTRL_CORE_PAD_VOUT1_CLK	D11	vout1_clk				vin4a_fld0	vin3a_fld0					spi3_cs0			gpio4_19	Driver off
0x15CC	CTRL_CORE_PAD_VOUT1_DE	B10	vout1_de				vin4a_de0	vin3a_de0					spi3_d1			gpio4_20	Driver off

表 4-3. Multiplexing Characteristics (continued)

ADDRESS	REGISTER NAME	BALL NUMBER	MUXMODE FIELD SETTINGS (CTRL_CORE_PAD_*[3:0])												
			0	1	2	3	4	5	6	7	8	9	10	14	15
0x15D0	CTRL_CORE_PAD_VOUT1_FLD	B11	vout1_fld			vin4a_clk0	vin3a_clk0					spi3_cs1		gpio4_21	Driver off
0x15D4	CTRL_CORE_PAD_VOUT1_HSYNC	C11	vout1_hsync			vin4a_hsync0	vin3a_hsync0					spi3_d0		gpio4_22	Driver off
0x15D8	CTRL_CORE_PAD_VOUT1_VSYNC	E11	vout1_vsync			vin4a_vsync0	vin3a_vsync0					spi3_sclk		gpio4_23	Driver off
0x15DC	CTRL_CORE_PAD_VOUT1_D0	F11	vout1_d0		uart5_rxd	vin4a_d16	vin3a_d16					spi3_cs2		gpio8_0	Driver off
0x15E0	CTRL_CORE_PAD_VOUT1_D1	G10	vout1_d1		uart5_txd	vin4a_d17	vin3a_d17							gpio8_1	Driver off
0x15E4	CTRL_CORE_PAD_VOUT1_D2	F10	vout1_d2		emu2	vin4a_d18	vin3a_d18	obs0	obs16	obs_irq1				gpio8_2	Driver off
0x15E8	CTRL_CORE_PAD_VOUT1_D3	G11	vout1_d3		emu5	vin4a_d19	vin3a_d19	obs1	obs17	obs_dmarq1				gpio8_3	Driver off
0x15EC	CTRL_CORE_PAD_VOUT1_D4	E9	vout1_d4		emu6	vin4a_d20	vin3a_d20	obs2	obs18					gpio8_4	Driver off
0x15F0	CTRL_CORE_PAD_VOUT1_D5	F9	vout1_d5		emu7	vin4a_d21	vin3a_d21	obs3	obs19					gpio8_5	Driver off
0x15F4	CTRL_CORE_PAD_VOUT1_D6	F8	vout1_d6		emu8	vin4a_d22	vin3a_d22	obs4	obs20					gpio8_6	Driver off
0x15F8	CTRL_CORE_PAD_VOUT1_D7	E7	vout1_d7		emu9	vin4a_d23	vin3a_d23							gpio8_7	Driver off
0x15FC	CTRL_CORE_PAD_VOUT1_D8	E8	vout1_d8		uart6_rxd	vin4a_d8	vin3a_d8							gpio8_8	Driver off
0x1600	CTRL_CORE_PAD_VOUT1_D9	D9	vout1_d9		uart6_txd	vin4a_d9	vin3a_d9							gpio8_9	Driver off
0x1604	CTRL_CORE_PAD_VOUT1_D10	D7	vout1_d10		emu3	vin4a_d10	vin3a_d10	obs5	obs21	obs_irq2				gpio8_10	Driver off
0x1608	CTRL_CORE_PAD_VOUT1_D11	D8	vout1_d11		emu10	vin4a_d11	vin3a_d11	obs6	obs22	obs_dmarq2				gpio8_11	Driver off
0x160C	CTRL_CORE_PAD_VOUT1_D12	A5	vout1_d12		emu11	vin4a_d12	vin3a_d12	obs7	obs23					gpio8_12	Driver off
0x1610	CTRL_CORE_PAD_VOUT1_D13	C6	vout1_d13		emu12	vin4a_d13	vin3a_d13	obs8	obs24					gpio8_13	Driver off
0x1614	CTRL_CORE_PAD_VOUT1_D14	C8	vout1_d14		emu13	vin4a_d14	vin3a_d14	obs9	obs25					gpio8_14	Driver off
0x1618	CTRL_CORE_PAD_VOUT1_D15	C7	vout1_d15		emu14	vin4a_d15	vin3a_d15	obs10	obs26					gpio8_15	Driver off
0x161C	CTRL_CORE_PAD_VOUT1_D16	B7	vout1_d16		uart7_rxd	vin4a_d0	vin3a_d0							gpio8_16	Driver off
0x1620	CTRL_CORE_PAD_VOUT1_D17	B8	vout1_d17		uart7_txd	vin4a_d1	vin3a_d1							gpio8_17	Driver off
0x1624	CTRL_CORE_PAD_VOUT1_D18	A7	vout1_d18		emu4	vin4a_d2	vin3a_d2	obs11	obs27					gpio8_18	Driver off
0x1628	CTRL_CORE_PAD_VOUT1_D19	A8	vout1_d19		emu15	vin4a_d3	vin3a_d3	obs12	obs28					gpio8_19	Driver off
0x162C	CTRL_CORE_PAD_VOUT1_D20	C9	vout1_d20		emu16	vin4a_d4	vin3a_d4	obs13	obs29					gpio8_20	Driver off

表 4-3. Multiplexing Characteristics (continued)

ADDRESS	REGISTER NAME	BALL NUMBER	MUXMODE FIELD SETTINGS (CTRL_CORE_PAD_*[3:0])													
			0	1	2	3	4	5	6	7	8	9	10	14	15	
0x1630	CTRL_CORE_PAD_VOUT1_D21	A9	vout1_d21		emu17	vin4a_d5	vin3a_d5	obs14	obs30						gpio8_21	Driver off
0x1634	CTRL_CORE_PAD_VOUT1_D22	B9	vout1_d22		emu18	vin4a_d6	vin3a_d6	obs15	obs31						gpio8_22	Driver off
0x1638	CTRL_CORE_PAD_VOUT1_D23	A10	vout1_d23		emu19	vin4a_d7	vin3a_d7						spi3_cs3		gpio8_23	Driver off
0x163C	CTRL_CORE_PAD_MDIO_MCLK	V1	mdio_mclk	uart3_rtsn		mii0_col	vin2a_clk0	vin4b_clk1							gpio5_15	Driver off
0x1640	CTRL_CORE_PAD_MDIO_D	U4	mdio_d	uart3_ctsn		mii0_txer	vin2a_d0	vin4b_d0							gpio5_16	Driver off
0x1644	CTRL_CORE_PAD_RMII_MHZ_50_CLK	U3	RMII_MHZ_50_CLK				vin2a_d11								gpio5_17	Driver off
0x1648	CTRL_CORE_PAD_UART3_RXD	V2	uart3_rxd		rmii1_crs	mii0_rxdv	vin2a_d1	vin4b_d1				spi3_sclk			gpio5_18	Driver off
0x164C	CTRL_CORE_PAD_UART3_TXD	Y1	uart3_txd		rmii1_rxer	mii0_rxclk	vin2a_d2	vin4b_d2				spi3_d1	spi4_cs1		gpio5_19	Driver off
0x1650	CTRL_CORE_PAD_RGMII0_TXC	W9	rgmii0_txc	uart3_ctsn	rmii1_rxd1	mii0_rxd3	vin2a_d3	vin4b_d3	usb4_ulpi_clk	spi3_d0	spi4_cs2				gpio5_20	Driver off
0x1654	CTRL_CORE_PAD_RGMII0_TXCTL	V9	rgmii0_txctl	uart3_rtsn	rmii1_rxd0	mii0_rxd2	vin2a_d4	vin4b_d4	usb4_ulpi_stp	spi3_cs0	spi4_cs3				gpio5_21	Driver off
0x1658	CTRL_CORE_PAD_RGMII0_TXD3	V7	rgmii0_txd3	rmii0_crs		mii0_crs	vin2a_de0	vin4b_de1	usb4_ulpi_dir	spi4_sclk	uart4_rxd				gpio5_22	Driver off
0x165C	CTRL_CORE_PAD_RGMII0_TXD2	U7	rgmii0_txd2	rmii0_rxer		mii0_rxer	vin2a_hsync0	vin4b_hsync1	usb4_ulpi_nxt	spi4_d1	uart4_txd				gpio5_23	Driver off
0x1660	CTRL_CORE_PAD_RGMII0_TXD1	V6	rgmii0_txd1	rmii0_rxd1		mii0_rxd1	vin2a_vsync0	vin4b_vsync1	usb4_ulpi_d0	spi4_d0	uart4_ctsn				gpio5_24	Driver off
0x1664	CTRL_CORE_PAD_RGMII0_TXD0	U6	rgmii0_txd0	rmii0_rxd0		mii0_rxd0	vin2a_d10		usb4_ulpi_d1	spi4_cs0	uart4_rtsn				gpio5_25	Driver off
0x1668	CTRL_CORE_PAD_RGMII0_RXC	U5	rgmii0_rxc		rmii1_txen	mii0_txclk	vin2a_d5	vin4b_d5	usb4_ulpi_d2						gpio5_26	Driver off
0x166C	CTRL_CORE_PAD_RGMII0_RXCTL	V5	rgmii0_rxctl		rmii1_txd1	mii0_txd3	vin2a_d6	vin4b_d6	usb4_ulpi_d3						gpio5_27	Driver off
0x1670	CTRL_CORE_PAD_RGMII0_RXD3	V4	rgmii0_rxd3		rmii1_txd0	mii0_txd2	vin2a_d7	vin4b_d7	usb4_ulpi_d4						gpio5_28	Driver off
0x1674	CTRL_CORE_PAD_RGMII0_RXD2	V3	rgmii0_rxd2	rmii0_txen		mii0_txen	vin2a_d8		usb4_ulpi_d5						gpio5_29	Driver off
0x1678	CTRL_CORE_PAD_RGMII0_RXD1	Y2	rgmii0_rxd1	rmii0_txd1		mii0_txd1	vin2a_d9		usb4_ulpi_d6						gpio5_30	Driver off
0x167C	CTRL_CORE_PAD_RGMII0_RXD0	W2	rgmii0_rxd0	rmii0_txd0		mii0_txd0	vin2a_fld0	vin4b_fld1	usb4_ulpi_d7						gpio5_31	Driver off
0x1680	CTRL_CORE_PAD_USB1_DRVVBUS	AB10	usb1_drvvbus								timer16				gpio6_12	Driver off
0x1684	CTRL_CORE_PAD_USB2_DRVVBUS	AC10	usb2_drvvbus								timer15				gpio6_13	Driver off
0x1688	CTRL_CORE_PAD_GPIO6_14	E21	gpio6_14	mcasp1_axr8	dcan2_tx	uart10_rxd			vout2_hsync		vin4a_hsync0	i2c3_sda	timer1		gpio6_14	Driver off
0x168C	CTRL_CORE_PAD_GPIO6_15	F20	gpio6_15	mcasp1_axr9	dcan2_rx	uart10_txd			vout2_vsync		vin4a_vsync0	i2c3_scl	timer2		gpio6_15	Driver off

表 4-3. Multiplexing Characteristics (continued)

ADDRESS	REGISTER NAME	BALL NUMBER	MUXMODE FIELD SETTINGS (CTRL_CORE_PAD_*[3:0])													
			0	1	2	3	4	5	6	7	8	9	10	14	15	
0x1690	CTRL_CORE_PAD_GPIO6_16	F21	gpio6_16	mcasp1_axr10						vout2_fld		vin4a_fld0	clkout1	timer3	gpio6_16	Driver off
0x1694	CTRL_CORE_PAD_XREF_CLK0	D18	xref_clk0	mcasp2_axr8	mcasp1_axr4	mcasp1_ahclkx	mcasp5_ahclkx	atl_clk0			vin6a_d0	hdq0	clkout2	timer13	gpio6_17	Driver off
0x1698	CTRL_CORE_PAD_XREF_CLK1	E17	xref_clk1	mcasp2_axr9	mcasp1_axr5	mcasp2_ahclkx	mcasp6_ahclkx	atl_clk1			vin6a_clk0			timer14	gpio6_18	Driver off
0x169C	CTRL_CORE_PAD_XREF_CLK2	B26	xref_clk2	mcasp2_axr10	mcasp1_axr6	mcasp3_ahclkx	mcasp7_ahclkx	atl_clk2		vout2_clk		vin4a_clk0		timer15	gpio6_19	Driver off
0x16A0	CTRL_CORE_PAD_XREF_CLK3	C23	xref_clk3	mcasp2_axr11	mcasp1_axr7	mcasp4_ahclkx	mcasp8_ahclkx	atl_clk3		vout2_de	hdq0	vin4a_de0	clkout3	timer16	gpio6_20	Driver off
0x16A4	CTRL_CORE_PAD_MCASP1_ACLKX	C14	mcasp1_aclkx								vin6a_fld0			i2c3_sda	gpio7_31	Driver off
0x16A8	CTRL_CORE_PAD_MCASP1_FSX	D14	mcasp1_fsx								vin6a_de0			i2c3_scl	gpio7_30	Driver off
0x16AC	CTRL_CORE_PAD_MCASP1_ACLKR	B14	mcasp1_aclkr	mcasp7_axr2						vout2_d0		vin4a_d0		i2c4_sda	gpio5_0	Driver off
0x16B0	CTRL_CORE_PAD_MCASP1_FSR	J14	mcasp1_fsr	mcasp7_axr3						vout2_d1		vin4a_d1		i2c4_scl	gpio5_1	Driver off
0x16B4	CTRL_CORE_PAD_MCASP1_AXR0	G12	mcasp1_axr0			uart6_rxd					vin6a_vsync0			i2c5_sda	gpio5_2	Driver off
0x16B8	CTRL_CORE_PAD_MCASP1_AXR1	F12	mcasp1_axr1			uart6_txd					vin6a_hsync0			i2c5_scl	gpio5_3	Driver off
0x16BC	CTRL_CORE_PAD_MCASP1_AXR2	G13	mcasp1_axr2	mcasp6_axr2		uart6_ctsn				vout2_d2		vin4a_d2			gpio5_4	Driver off
0x16C0	CTRL_CORE_PAD_MCASP1_AXR3	J11	mcasp1_axr3	mcasp6_axr3		uart6_rtsn				vout2_d3		vin4a_d3			gpio5_5	Driver off
0x16C4	CTRL_CORE_PAD_MCASP1_AXR4	E12	mcasp1_axr4	mcasp4_axr2						vout2_d4		vin4a_d4			gpio5_6	Driver off
0x16C8	CTRL_CORE_PAD_MCASP1_AXR5	F13	mcasp1_axr5	mcasp4_axr3						vout2_d5		vin4a_d5			gpio5_7	Driver off
0x16CC	CTRL_CORE_PAD_MCASP1_AXR6	C12	mcasp1_axr6	mcasp5_axr2						vout2_d6		vin4a_d6			gpio5_8	Driver off
0x16D0	CTRL_CORE_PAD_MCASP1_AXR7	D12	mcasp1_axr7	mcasp5_axr3						vout2_d7		vin4a_d7		timer4	gpio5_9	Driver off
0x16D4	CTRL_CORE_PAD_MCASP1_AXR8	B12	mcasp1_axr8	mcasp6_axr0		spi3_sclk					vin6a_d15			timer5	gpio5_10	Driver off
0x16D8	CTRL_CORE_PAD_MCASP1_AXR9	A11	mcasp1_axr9	mcasp6_axr1		spi3_d1					vin6a_d14			timer6	gpio5_11	Driver off
0x16DC	CTRL_CORE_PAD_MCASP1_AXR10	B13	mcasp1_axr10	mcasp6_aclkx	mcasp6_aclkr	spi3_d0					vin6a_d13			timer7	gpio5_12	Driver off
0x16E0	CTRL_CORE_PAD_MCASP1_AXR11	A12	mcasp1_axr11	mcasp6_fsx	mcasp6_fsr	spi3_cs0					vin6a_d12			timer8	gpio4_17	Driver off
0x16E4	CTRL_CORE_PAD_MCASP1_AXR12	E14	mcasp1_axr12	mcasp7_axr0		spi3_cs1					vin6a_d11			timer9	gpio4_18	Driver off
0x16E8	CTRL_CORE_PAD_MCASP1_AXR13	A13	mcasp1_axr13	mcasp7_axr1							vin6a_d10			timer10	gpio6_4	Driver off
0x16EC	CTRL_CORE_PAD_MCASP1_AXR14	G14	mcasp1_axr14	mcasp7_aclkx	mcasp7_aclkr						vin6a_d9			timer11	gpio6_5	Driver off

表 4-3. Multiplexing Characteristics (continued)

ADDRESS	REGISTER NAME	BALL NUMBER	MUXMODE FIELD SETTINGS (CTRL_CORE_PAD_*[3:0])													
			0	1	2	3	4	5	6	7	8	9	10	14	15	
0x16F0	CTRL_CORE_PAD_MCASP1_AXR15	F14	mcasp1_axr15	mcasp7_fsx	mcasp7_fsr						vin6a_d8			timer12	gpio6_6	Driver off
0x16F4	CTRL_CORE_PAD_MCASP2_ACLKX	A19	mcasp2_aclkx								vin6a_d7					Driver off
0x16F8	CTRL_CORE_PAD_MCASP2_FSX	A18	mcasp2_fsx								vin6a_d6					Driver off
0x16FC	CTRL_CORE_PAD_MCASP2_ACLKR	E15	mcasp2_aclkr	mcasp8_axr2						vout2_d8		vin4a_d8				Driver off
0x1700	CTRL_CORE_PAD_MCASP2_FSR	A20	mcasp2_fsr	mcasp8_axr3						vout2_d9		vin4a_d9				Driver off
0x1704	CTRL_CORE_PAD_MCASP2_AXR0	B15	mcasp2_axr0							vout2_d10		vin4a_d10				Driver off
0x1708	CTRL_CORE_PAD_MCASP2_AXR1	A15	mcasp2_axr1							vout2_d11		vin4a_d11				Driver off
0x170C	CTRL_CORE_PAD_MCASP2_AXR2	C15	mcasp2_axr2	mcasp3_axr2							vin6a_d5				gpio6_8	Driver off
0x1710	CTRL_CORE_PAD_MCASP2_AXR3	A16	mcasp2_axr3	mcasp3_axr3							vin6a_d4				gpio6_9	Driver off
0x1714	CTRL_CORE_PAD_MCASP2_AXR4	D15	mcasp2_axr4	mcasp8_axr0						vout2_d12		vin4a_d12			gpio1_4	Driver off
0x1718	CTRL_CORE_PAD_MCASP2_AXR5	B16	mcasp2_axr5	mcasp8_axr1						vout2_d13		vin4a_d13			gpio6_7	Driver off
0x171C	CTRL_CORE_PAD_MCASP2_AXR6	B17	mcasp2_axr6	mcasp8_aclkx	mcasp8_aclkr					vout2_d14		vin4a_d14			gpio2_29	Driver off
0x1720	CTRL_CORE_PAD_MCASP2_AXR7	A17	mcasp2_axr7	mcasp8_fsx	mcasp8_fsr					vout2_d15		vin4a_d15			gpio1_5	Driver off
0x1724	CTRL_CORE_PAD_MCASP3_ACLKX	B18	mcasp3_aclkx	mcasp3_aclkr	mcasp2_axr12	uart7_rxd					vin6a_d3				gpio5_13	Driver off
0x1728	CTRL_CORE_PAD_MCASP3_FSX	F15	mcasp3_fsx	mcasp3_fsr	mcasp2_axr13	uart7_txd					vin6a_d2				gpio5_14	Driver off
0x172C	CTRL_CORE_PAD_MCASP3_AXR0	B19	mcasp3_axr0		mcasp2_axr14	uart7_ctsn	uart5_rxd				vin6a_d1					Driver off
0x1730	CTRL_CORE_PAD_MCASP3_AXR1	C17	mcasp3_axr1		mcasp2_axr15	uart7_rtsn	uart5_txd				vin6a_d0		vin5a_fid0			Driver off
0x1734	CTRL_CORE_PAD_MCASP4_ACLKX	C18	mcasp4_aclkx	mcasp4_aclkr	spi3_sclk	uart8_rxd	i2c4_sda			vout2_d16		vin4a_d16	vin5a_d15			Driver off
0x1738	CTRL_CORE_PAD_MCASP4_FSX	A21	mcasp4_fsx	mcasp4_fsr	spi3_d1	uart8_txd	i2c4_scl			vout2_d17		vin4a_d17	vin5a_d14			Driver off
0x173C	CTRL_CORE_PAD_MCASP4_AXR0	G16	mcasp4_axr0		spi3_d0	uart8_ctsn	uart4_rxd			vout2_d18		vin4a_d18	vin5a_d13			Driver off
0x1740	CTRL_CORE_PAD_MCASP4_AXR1	D17	mcasp4_axr1		spi3_cs0	uart8_rtsn	uart4_txd			vout2_d19		vin4a_d19	vin5a_d12			Driver off
0x1744	CTRL_CORE_PAD_MCASP5_ACLKX	AA3	mcasp5_aclkx	mcasp5_aclkr	spi4_sclk	uart9_rxd	i2c5_sda	mlb_clk		vout2_d20		vin4a_d20	vin5a_d11			Driver off
0x1748	CTRL_CORE_PAD_MCASP5_FSX	AB9	mcasp5_fsx	mcasp5_fsr	spi4_d1	uart9_txd	i2c5_scl			vout2_d21		vin4a_d21	vin5a_d10			Driver off
0x174C	CTRL_CORE_PAD_MCASP5_AXR0	AB3	mcasp5_axr0		spi4_d0	uart9_ctsn	uart3_rxd	mlb_sig		vout2_d22		vin4a_d22	vin5a_d9			Driver off

表 4-3. Multiplexing Characteristics (continued)

ADDRESS	REGISTER NAME	BALL NUMBER	MUXMODE FIELD SETTINGS (CTRL_CORE_PAD_*[3:0])												
			0	1	2	3	4	5	6	7	8	9	10	14	15
0x1750	CTRL_CORE_PAD_MCAPSP5_AXR1	AA4	mcasp5_axr1		spi4_cs0	uart9_rtsn	uart3_txd	mib_dat	vout2_d23		vin4a_d23	vin5a_d8			Driver off
0x1754	CTRL_CORE_PAD_MMC1_CLK	W6	mmc1_clk											gpio6_21	Driver off
0x1758	CTRL_CORE_PAD_MMC1_CMD	Y6	mmc1_cmd											gpio6_22	Driver off
0x175C	CTRL_CORE_PAD_MMC1_DAT0	AA6	mmc1_dat0											gpio6_23	Driver off
0x1760	CTRL_CORE_PAD_MMC1_DAT1	Y4	mmc1_dat1											gpio6_24	Driver off
0x1764	CTRL_CORE_PAD_MMC1_DAT2	AA5	mmc1_dat2											gpio6_25	Driver off
0x1768	CTRL_CORE_PAD_MMC1_DAT3	Y3	mmc1_dat3											gpio6_26	Driver off
0x176C	CTRL_CORE_PAD_MMC1_SDCCD	W7	mmc1_sdccd				uart6_rxd	i2c4_sda						gpio6_27	Driver off
0x1770	CTRL_CORE_PAD_MMC1_SDWP	Y9	mmc1_sdwp				uart6_txd	i2c4_scl						gpio6_28	Driver off
0x1774	CTRL_CORE_PAD_GPIO6_10	AC5	gpio6_10	mdio_mclk	i2c3_sda	usb3_ulpi_d7	vin2b_hsync1					vin5a_clk0	ehrpwm2A	gpio6_10	Driver off
0x1778	CTRL_CORE_PAD_GPIO6_11	AB4	gpio6_11	mdio_d	i2c3_scl	usb3_ulpi_d6	vin2b_vsync1					vin5a_de0	ehrpwm2B	gpio6_11	Driver off
0x177C	CTRL_CORE_PAD_MMC3_CLK	AD4	mmc3_clk			usb3_ulpi_d5	vin2b_d7					vin5a_d7	ehrpwm2_trip zone_input	gpio6_29	Driver off
0x1780	CTRL_CORE_PAD_MMC3_CMD	AC4	mmc3_cmd	spi3_sclk		usb3_ulpi_d4	vin2b_d6					vin5a_d6	eCAP2_in_P WM2_out	gpio6_30	Driver off
0x1784	CTRL_CORE_PAD_MMC3_DAT0	AC7	mmc3_dat0	spi3_d1	uart5_rxd	usb3_ulpi_d3	vin2b_d5					vin5a_d5	eQEP3A_in	gpio6_31	Driver off
0x1788	CTRL_CORE_PAD_MMC3_DAT1	AC6	mmc3_dat1	spi3_d0	uart5_txd	usb3_ulpi_d2	vin2b_d4					vin5a_d4	eQEP3B_in	gpio7_0	Driver off
0x178C	CTRL_CORE_PAD_MMC3_DAT2	AC9	mmc3_dat2	spi3_cs0	uart5_ctsn	usb3_ulpi_d1	vin2b_d3					vin5a_d3	eQEP3_index	gpio7_1	Driver off
0x1790	CTRL_CORE_PAD_MMC3_DAT3	AC3	mmc3_dat3	spi3_cs1	uart5_rtsn	usb3_ulpi_d0	vin2b_d2					vin5a_d2	eQEP3_strobe	gpio7_2	Driver off
0x1794	CTRL_CORE_PAD_MMC3_DAT4	AC8	mmc3_dat4	spi4_sclk	uart10_rxd	usb3_ulpi_nxt	vin2b_d1					vin5a_d1	ehrpwm3A	gpio1_22	Driver off
0x1798	CTRL_CORE_PAD_MMC3_DAT5	AD6	mmc3_dat5	spi4_d1	uart10_txd	usb3_ulpi_dir	vin2b_d0					vin5a_d0	ehrpwm3B	gpio1_23	Driver off
0x179C	CTRL_CORE_PAD_MMC3_DAT6	AB8	mmc3_dat6	spi4_d0	uart10_ctsn	usb3_ulpi_stp	vin2b_de1					vin5a_hsync0	ehrpwm3_trip zone_input	gpio1_24	Driver off
0x17A0	CTRL_CORE_PAD_MMC3_DAT7	AB5	mmc3_dat7	spi4_cs0	uart10_rtsn	usb3_ulpi_clk	vin2b_clk1					vin5a_vsync0	eCAP3_in_P WM3_out	gpio1_25	Driver off
0x17A4	CTRL_CORE_PAD_SPI1_SCLK	A25	spi1_sclk											gpio7_7	Driver off
0x17A8	CTRL_CORE_PAD_SPI1_D1	F16	spi1_d1											gpio7_8	Driver off
0x17AC	CTRL_CORE_PAD_SPI1_D0	B25	spi1_d0											gpio7_9	Driver off

表 4-3. Multiplexing Characteristics (continued)

ADDRESS	REGISTER NAME	BALL NUMBER	MUXMODE FIELD SETTINGS (CTRL_CORE_PAD_*[3:0])													
			0	1	2	3	4	5	6	7	8	9	10	14	15	
0x17B0	CTRL_CORE_PAD_S PI1_CS0	A24	spi1_cs0												gpio7_10	Driver off
0x17B4	CTRL_CORE_PAD_S PI1_CS1	A22	spi1_cs1		sata1_led	spi2_cs1									gpio7_11	Driver off
0x17B8	CTRL_CORE_PAD_S PI1_CS2	B21	spi1_cs2	uart4_rxd	mmc3_sdcd	spi2_cs2	dcan2_tx	mdio_mclk	hdmi1_hpd						gpio7_12	Driver off
0x17BC	CTRL_CORE_PAD_S PI1_CS3	B20	spi1_cs3	uart4_txd	mmc3_sdwp	spi2_cs3	dcan2_rx	mdio_d	hdmi1_cec						gpio7_13	Driver off
0x17C0	CTRL_CORE_PAD_S PI2_SCLK	A26	spi2_sclk	uart3_rxd											gpio7_14	Driver off
0x17C4	CTRL_CORE_PAD_S PI2_D1	B22	spi2_d1	uart3_txd											gpio7_15	Driver off
0x17C8	CTRL_CORE_PAD_S PI2_D0	G17	spi2_d0	uart3_ctsn	uart5_rxd										gpio7_16	Driver off
0x17CC	CTRL_CORE_PAD_S PI2_CS0	B24	spi2_cs0	uart3_rtsn	uart5_txd										gpio7_17	Driver off
0x17D0	CTRL_CORE_PAD_D CAN1_TX	G20	dcan1_tx		uart8_rxd	mmc2_sdcd				hdmi1_hpd					gpio1_14	Driver off
0x17D4	CTRL_CORE_PAD_D CAN1_RX	G19	dcan1_rx		uart8_txd	mmc2_sdwp	sata1_led			hdmi1_cec					gpio1_15	Driver off
0x17E0	CTRL_CORE_PAD_U ART1_RXD	B27	uart1_rxd			mmc4_sdcd									gpio7_22	Driver off
0x17E4	CTRL_CORE_PAD_U ART1_TXD	C26	uart1_txd			mmc4_sdwp									gpio7_23	Driver off
0x17E8	CTRL_CORE_PAD_U ART1_CTSN	E25	uart1_ctsn		uart9_rxd	mmc4_clk									gpio7_24	Driver off
0x17EC	CTRL_CORE_PAD_U ART1_RTSN	C27	uart1_rtsn		uart9_txd	mmc4_cmd									gpio7_25	Driver off
0x17F0	CTRL_CORE_PAD_U ART2_RXD	D28		uart3_ctsn	uart3_rctx	mmc4_dat0	uart2_rxd	uart1_dcdn							gpio7_26	Driver off
0x17F4	CTRL_CORE_PAD_U ART2_TXD	D26	uart2_txd	uart3_rtsn	uart3_sd	mmc4_dat1	uart2_txd	uart1_dsrn							gpio7_27	Driver off
0x17F8	CTRL_CORE_PAD_U ART2_CTSN	D27	uart2_ctsn		uart3_rxd	mmc4_dat2	uart10_rxd	uart1_dtrn							gpio1_16	Driver off
0x17FC	CTRL_CORE_PAD_U ART2_RTSN	C28	uart2_rtsn	uart3_txd	uart3_jrtx	mmc4_dat3	uart10_txd	uart1_rin							gpio1_17	Driver off
0x1800	CTRL_CORE_PAD_I 2C1_SDA	C21	i2c1_sda													
0x1804	CTRL_CORE_PAD_I 2C1_SCL	C20	i2c1_scl													
0x1808	CTRL_CORE_PAD_I 2C2_SDA	C25	i2c2_sda	hdmi1_ddc_sc l												Driver off
0x180C	CTRL_CORE_PAD_I 2C2_SCL	F17	i2c2_scl	hdmi1_ddc_sd a												Driver off
0x1818	CTRL_CORE_PAD_ WAKEUP0	AD17	Wakeup0	dcan1_rx											gpio1_0	Driver off
0x181C	CTRL_CORE_PAD_ WAKEUP1	AC17	Wakeup1	dcan2_rx											gpio1_1	Driver off

表 4-3. Multiplexing Characteristics (continued)

ADDRESS	REGISTER NAME	BALL NUMBER	MUXMODE FIELD SETTINGS (CTRL_CORE_PAD_*[3:0])													
			0	1	2	3	4	5	6	7	8	9	10	14	15	
0x1820	CTRL_CORE_PAD_WAKEUP2	AB16	Wakeup2	sys_nirq2											gpio1_2	Driver off
0x1824	CTRL_CORE_PAD_WAKEUP3	AC16	Wakeup3	sys_nirq1											gpio1_3	Driver off
0x1828	CTRL_CORE_PAD_ON_OFF	Y11	on_off													
0x182C	CTRL_CORE_PAD_RTC_PORZ	AB17	rtc_porz													
0x1830	CTRL_CORE_PAD_TMS	F18	tms													
0x1834	CTRL_CORE_PAD_TDI	D23	tdi												gpio8_27	
0x1838	CTRL_CORE_PAD_TDO	F19	tdo												gpio8_28	
0x183C	CTRL_CORE_PAD_TCLK	E20	tclk													
0x1840	CTRL_CORE_PAD_TRSTN	D20	trstn													
0x1844	CTRL_CORE_PAD_RTCK	E18	rtck												gpio8_29	
0x1848	CTRL_CORE_PAD_EMU0	G21	emu0												gpio8_30	
0x184C	CTRL_CORE_PAD_EMU1	D24	emu1												gpio8_31	
0x185C	CTRL_CORE_PAD_RESETN	E23	resetrn													
0x1860	CTRL_CORE_PAD_NMIN_DSP	D21	nmin_dsp													
0x1864	CTRL_CORE_PAD_RSTOUTN	F23	rstoutn													

1. NA in table stands for Not Applicable.

4.4 Signal Descriptions

Many signals are available on multiple pins, according to the software configuration of the pin multiplexing options.

1. **SIGNAL NAME:** The name of the signal passing through the pin.

注: The subsystem multiplexing signals are not described in 表 4-2 and 表 4-3.

2. **DESCRIPTION:** Description of the signal

3. **TYPE:** Signal direction and type:

- I = Input
- O = Output
- IO = Input or output
- D = Open Drain
- DS = Differential
- A = Analog
- PWR = Power
- GND = Ground

4. **BALL:** Associated ball(s) bottom

注: For more information, see the Control Module / Control Module Register Manual section of the device TRM.

4.4.1 Video Input Ports (VIP)

注: For more information, see the Video Input Port (VIP) section of the device TRM.

注意

The I/O timings provided in 7, *Timing Requirements and Switching Characteristics* are applicable for all combinations of signals for vin1, vin5 and vin6. However, the timings are only valid for vin2, vin3, and vin4 if signals within a single IOSET are used. The IOSETs are defined in the 表 7-4, 表 7-5 and 表 7-6.

表 4-4. VIP Signal Descriptions

SIGNAL NAME	DESCRIPTION	TYPE	BALL
Video Input 1			
vin1a_clk0	Video Input 1 Port A Clock input. Input clock for 8-bit 16-bit or 24-bit Port A video capture. Input data is sampled on the CLK0 edge.	I	AG8
vin1a_de0	Video Input 1 Data Enable input ⁽¹⁾	I	AD9
vin1a fld0	Video Input 1 Port A Field ID input ⁽¹⁾	I	AF9
vin1a_hsync0	Video Input 1 Port A Horizontal Sync input ⁽¹⁾	I	AE9
vin1a_vsync0	Video Input 1 Port A Vertical Sync input ⁽¹⁾	I	AF8
vin1a_d0	Video Input 1 Port A Data input ⁽¹⁾	I	AE8
vin1a_d1	Video Input 1 Port A Data input ⁽¹⁾	I	AD8
vin1a_d2	Video Input 1 Port A Data input ⁽¹⁾	I	AG7
vin1a_d3	Video Input 1 Port A Data input ⁽¹⁾	I	AH6
vin1a_d4	Video Input 1 Port A Data input ⁽¹⁾	I	AH3

表 4-4. VIP Signal Descriptions (continued)

SIGNAL NAME	DESCRIPTION	TYPE	BALL
vin1a_d5	Video Input 1 Port A Data input ⁽¹⁾	I	AH5
vin1a_d6	Video Input 1 Port A Data input ⁽¹⁾	I	AG6
vin1a_d7	Video Input 1 Port A Data input ⁽¹⁾	I	AH4
vin1a_d8	Video Input 1 Port A Data input ⁽¹⁾	I	AG4
vin1a_d9	Video Input 1 Port A Data input ⁽¹⁾	I	AG2
vin1a_d10	Video Input 1 Port A Data input ⁽¹⁾	I	AG3
vin1a_d11	Video Input 1 Port A Data input ⁽¹⁾	I	AG5
vin1a_d12	Video Input 1 Port A Data input ⁽¹⁾	I	AF2
vin1a_d13	Video Input 1 Port A Data input ⁽¹⁾	I	AF6
vin1a_d14	Video Input 1 Port A Data input ⁽¹⁾	I	AF3
vin1a_d15	Video Input 1 Port A Data input ⁽¹⁾	I	AF4
vin1a_d16	Video Input 1 Port A Data input ⁽¹⁾	I	AF1
vin1a_d17	Video Input 1 Port A Data input ⁽¹⁾	I	AE3
vin1a_d18	Video Input 1 Port A Data input ⁽¹⁾	I	AE5
vin1a_d19	Video Input 1 Port A Data input ⁽¹⁾	I	AE1
vin1a_d20	Video Input 1 Port A Data input ⁽¹⁾	I	AE2
vin1a_d21	Video Input 1 Port A Data input ⁽¹⁾	I	AE6
vin1a_d22	Video Input 1 Port A Data input ⁽¹⁾	I	AD2
vin1a_d23	Video Input 1 Port A Data input ⁽¹⁾	I	AD3
vin1b_hsync1	Video Input 1 Port B Horizontal Sync input ⁽¹⁾	I	N6 / AD9
vin1b_vsync1	Video Input 1 Port B Vertical Sync input ⁽¹⁾	I	AF9
vin1b fld1	Video Input 1 Port B Field ID input ⁽¹⁾	I	AE9
vin1b_de1	Video Input 1 Port B Data Enable input ⁽¹⁾	I	AF8 / M4
vin1b_clk1	Video Input 1 Port B Clock input ⁽¹⁾	I	AH7
vin1b_d0	Video Input 1 Port B Data input ⁽¹⁾	I	AF4 / AD3
vin1b_d1	Video Input 1 Port B Data input ⁽¹⁾	I	AF3 / AD2
vin1b_d2	Video Input 1 Port B Data input ⁽¹⁾	I	AF6 / AE6
vin1b_d3	Video Input 1 Port B Data input ⁽¹⁾	I	AF2 / AE2
vin1b_d4	Video Input 1 Port B Data input ⁽¹⁾	I	AG5 / AE1
vin1b_d5	Video Input 1 Port B Data input ⁽¹⁾	I	AG3 / AE5
vin1b_d6	Video Input 1 Port B Data input ⁽¹⁾	I	AG2 / AE3
vin1b_d7	Video Input 1 Port B Data input ⁽¹⁾	I	AG4 / AF1
Video Input 2			
vin2a_clk0	Video Input 2 Port A Clock input.	I	E1 / V1
vin2a_de0	Video Input 2 Port A Data Enable input	I	G2 / V7
vin2a fld0	Video Input 2 Port A Field ID input	I	H7 / G2 / W2
vin2a_hsync0	Video Input 2 Port A Horizontal Sync input	I	G1 / U7
vin2a_vsync0	Video Input 2 Port A Vertical Sync input	I	G6 / V6
vin2a_d0	Video Input 2 Port A Data input	I	F2 / U4
vin2a_d1	Video Input 2 Port A Data input	I	F3 / V2
vin2a_d2	Video Input 2 Port A Data input	I	D1 / Y1
vin2a_d3	Video Input 2 Port A Data input	I	E2 / W9
vin2a_d4	Video Input 2 Port A Data input	I	D2 / V9
vin2a_d5	Video Input 2 Port A Data input	I	F4 / U5
vin2a_d6	Video Input 2 Port A Data input	I	C1 / V5
vin2a_d7	Video Input 2 Port A Data input	I	E4 / V4
vin2a_d8	Video Input 2 Port A Data input	I	F5 / V3

表 4-4. VIP Signal Descriptions (continued)

SIGNAL NAME	DESCRIPTION	TYPE	BALL
vin2a_d9	Video Input 2 Port A Data input	I	E6 / Y2
vin2a_d10	Video Input 2 Port A Data input	I	D3 / U6
vin2a_d11	Video Input 2 Port A Data input	I	F6 / U3
vin2a_d12	Video Input 2 Port A Data input	I	D5
vin2a_d13	Video Input 2 Port A Data input	I	C2
vin2a_d14	Video Input 2 Port A Data input	I	C3
vin2a_d15	Video Input 2 Port A Data input	I	C4
vin2a_d16	Video Input 2 Port A Data input	I	B2
vin2a_d17	Video Input 2 Port A Data input	I	D6
vin2a_d18	Video Input 2 Port A Data input	I	C5
vin2a_d19	Video Input 2 Port A Data input	I	A3
vin2a_d20	Video Input 2 Port A Data input	I	B3
vin2a_d21	Video Input 2 Port A Data input	I	B4
vin2a_d22	Video Input 2 Port A Data input	I	B5
vin2a_d23	Video Input 2 Port A Data input	I	A4
vin2b_clk1	Video Input 2 Port B Clock input	I	AB5 / H7
vin2b_de1	Video Input 2 Port B Data Enable input	I	AB8 / G2
vin2b fld1	Video Input 2 Port B Field ID input	I	G2
vin2b_hsync1	Video Input 2 Port B Horizontal Sync input	I	AC5 / G1
vin2b_vsync1	Video Input 2 Port B Vertical Sync input	I	AB4 / G6
vin2b_d0	Video Input 2 Port B Data input	I	AD6 / A4
vin2b_d1	Video Input 2 Port B Data input	I	AC8 / B5
vin2b_d2	Video Input 2 Port B Data input	I	AC3 / B4
vin2b_d3	Video Input 2 Port B Data input	I	AC9 / B3
vin2b_d4	Video Input 2 Port B Data input	I	AC6 / A3
vin2b_d5	Video Input 2 Port B Data input	I	AC7 / C5
vin2b_d6	Video Input 2 Port B Data input	I	AC4 / D6
vin2b_d7	Video Input 2 Port B Data input	I	AD4 / B2
Video Input 3			
vin3a_clk0	Video Input 3 Port A Clock input	I	B11 / AH7 / P1
vin3a_de0	Video Input 3 Port A Data Enable input	I	N9 / B3 / B10
vin3a fld0	Video Input 3 Port A Field ID input	I	P9 / B4 / D11
vin3a_hsync0	Video Input 3 Port A Horizontal Sync input	I	N7 / B5 / C11
vin3a_vsync0	Video Input 3 Port A Vertical Sync input	I	R4 / A4 / E11
vin3a_d0	Video Input 3 Port A Data input	I	M6 / AF1 / B7
vin3a_d1	Video Input 3 Port A Data input	I	M2 / AE3 / B8
vin3a_d2	Video Input 3 Port A Data input	I	L5 / AE5 / A7
vin3a_d3	Video Input 3 Port A Data input	I	M1 / AE1 / A8
vin3a_d4	Video Input 3 Port A Data input	I	L6 / AE2 / C9
vin3a_d5	Video Input 3 Port A Data input	I	L4 / AE6 / A9
vin3a_d6	Video Input 3 Port A Data input	I	L3 / AD2 / B9
vin3a_d7	Video Input 3 Port A Data input	I	L2 / AD3 / A10
vin3a_d8	Video Input 3 Port A Data input	I	L1 / B2 / E8
vin3a_d9	Video Input 3 Port A Data input	I	K2 / D6 / D9
vin3a_d10	Video Input 3 Port A Data input	I	J1 / C5 / D7
vin3a_d11	Video Input 3 Port A Data input	I	J2 / A3 / D8
vin3a_d12	Video Input 3 Port A Data input	I	H1 / B3 / A5

表 4-4. VIP Signal Descriptions (continued)

SIGNAL NAME	DESCRIPTION	TYPE	BALL
vin3a_d13	Video Input 3 Port A Data input	I	J3 / B4 / C6
vin3a_d14	Video Input 3 Port A Data input	I	H2 / B5 / C8
vin3a_d15	Video Input 3 Port A Data input	I	H3 / A4 / C7
vin3a_d16	Video Input 3 Port A Data input	I	R6 / F11
vin3a_d17	Video Input 3 Port A Data input	I	T9 / G10
vin3a_d18	Video Input 3 Port A Data input	I	T6 / F10
vin3a_d19	Video Input 3 Port A Data input	I	T7 / G11
vin3a_d20	Video Input 3 Port A Data input	I	P6 / E9
vin3a_d21	Video Input 3 Port A Data input	I	R9 / F9
vin3a_d22	Video Input 3 Port A Data input	I	R5 / F8
vin3a_d23	Video Input 3 Port A Data input	I	P5 / E7
vin3b_clk1	Video Input 3 Port B Clock input	I	P7 / M4
vin3b_de1	Video Input 3 Port B Data Enable input	I	N6
vin3b fld1	Video Input 3 Port A Field ID input	I	M4
vin3b_hsync1	Video Input 3 Port A Horizontal Sync input	I	H5
vin3b_vsync1	Video Input 3 Port A Vertical Sync input	I	H6
vin3b_d0	Video Input 3 Port B Data input	I	K7
vin3b_d1	Video Input 3 Port B Data input	I	M7
vin3b_d2	Video Input 3 Port B Data input	I	J5
vin3b_d3	Video Input 3 Port B Data input	I	K6
vin3b_d4	Video Input 3 Port B Data input	I	J7
vin3b_d5	Video Input 3 Port B Data input	I	J4
vin3b_d6	Video Input 3 Port B Data input	I	J6
vin3b_d7	Video Input 3 Port B Data input	I	H4
Video Input 4			
vin4a_clk0	Video Input 4 Port A Clock input	I	P4 / B26 / B11
vin4a_de0	Video Input 4 Port A Data Enable input	I	H6 / C23 / B10 / P7
vin4a fld0	Video Input 4 Port A Field ID input	I	J7 / F21 / P9 / D11
vin4a_hsync0	Video Input 4 Port A Horizontal Sync input	I	R3 / E21 / C11 / P7
vin4a_vsync0	Video Input 4 Port A Vertical Sync input	I	T2 / F20 / E11 / N1
vin4a_d0	Video Input 4 Port A Data input	I	R6 / B7 / B14
vin4a_d1	Video Input 4 Port A Data input	I	T9 / B8 / J14
vin4a_d2	Video Input 4 Port A Data input	I	T6 / A7 / G13
vin4a_d3	Video Input 4 Port A Data input	I	T7 / A8 / J11
vin4a_d4	Video Input 4 Port A Data input	I	P6 / C9 / E12
vin4a_d5	Video Input 4 Port A Data input	I	R9 / A9 / F13
vin4a_d6	Video Input 4 Port A Data input	I	R5 / B9 / C12
vin4a_d7	Video Input 4 Port A Data input	I	P5 / A10 / D12
vin4a_d8	Video Input 4 Port A Data input	I	E8 / U2 / E15
vin4a_d9	Video Input 4 Port A Data input	I	D9 / U1 / A20
vin4a_d10	Video Input 4 Port A Data input	I	D7 / P3 / B15
vin4a_d11	Video Input 4 Port A Data input	I	D8 / R2 / A15
vin4a_d12	Video Input 4 Port A Data input	I	A5 / K7 / D15
vin4a_d13	Video Input 4 Port A Data input	I	C6 / M7 / B16
vin4a_d14	Video Input 4 Port A Data input	I	C8 / J5 / B17
vin4a_d15	Video Input 4 Port A Data input	I	C7 / K6 / A17
vin4a_d16	Video Input 4 Port A Data input	I	C18 / F11

表 4-4. VIP Signal Descriptions (continued)

SIGNAL NAME	DESCRIPTION	TYPE	BALL
vin4a_d17	Video Input 4 Port A Data input	I	A21 / G10
vin4a_d18	Video Input 4 Port A Data input	I	G16 / F10
vin4a_d19	Video Input 4 Port A Data input	I	D17 / G11
vin4a_d20	Video Input 4 Port A Data input	I	AA3 / E9
vin4a_d21	Video Input 4 Port A Data input	I	AB9 / F9
vin4a_d22	Video Input 4 Port A Data input	I	AB3 / F8
vin4a_d23	Video Input 4 Port A Data input	I	AA4 / E7
vin4b_clk1	Video Input 4 Port B Clock input	I	N9 / V1
vin4b_de1	Video Input 4 Port B Data Enable input	I	P9 / V7
vin4b_fid1	Video Input 4 Port B Field ID input	I	P4 / W2
vin4b_hsync1	Video Input 4 Port B Horizontal Sync input	I	N7 / U7
vin4b_vsync1	Video Input 4 Port B Vertical Sync input	I	R4 / V6
vin4b_d0	Video Input 4 Port B Data input	I	R6 / U4
vin4b_d1	Video Input 4 Port B Data input	I	T9 / V2
vin4b_d2	Video Input 4 Port B Data input	I	T6 / Y1
vin4b_d3	Video Input 4 Port B Data input	I	T7 / W9
vin4b_d4	Video Input 4 Port B Data input	I	P6 / V9
vin4b_d5	Video Input 4 Port B Data input	I	R9 / U5
vin4b_d6	Video Input 4 Port B Data input	I	R5 / V5
vin4b_d7	Video Input 4 Port B Data input	I	P5 / V4
Video Input 5			
vin5a_clk0	Video Input 5 Port A Clock input ⁽²⁾	I	AC5
vin5a_de0	Video Input 5 Port A Data Enable input ⁽²⁾	I	AB4
vin5a_fid0	Video Input 5 Port A Field ID input ⁽²⁾	I	C17
vin5a_hsync0	Video Input 5 Port A Horizontal Sync input ⁽²⁾	I	AB8
vin5a_vsync0	Video Input 5 Port A Vertical Sync input ⁽²⁾	I	AB5
vin5a_d0	Video Input 5 Port A Data input ⁽²⁾	I	AD6
vin5a_d1	Video Input 5 Port A Data input ⁽²⁾	I	AC8
vin5a_d2	Video Input 5 Port A Data input ⁽²⁾	I	AC3
vin5a_d3	Video Input 5 Port A Data input ⁽²⁾	I	AC9
vin5a_d4	Video Input 5 Port A Data input ⁽²⁾	I	AC6
vin5a_d5	Video Input 5 Port A Data input ⁽²⁾	I	AC7
vin5a_d6	Video Input 5 Port A Data input ⁽²⁾	I	AC4
vin5a_d7	Video Input 5 Port A Data input ⁽²⁾	I	AD4
vin5a_d8	Video Input 5 Port A Data input ⁽²⁾	I	AA4
vin5a_d9	Video Input 5 Port A Data input ⁽²⁾	I	AB3
vin5a_d10	Video Input 5 Port A Data input ⁽²⁾	I	AB9
vin5a_d11	Video Input 5 Port A Data input ⁽²⁾	I	AA3
vin5a_d12	Video Input 5 Port A Data input ⁽²⁾	I	D17
vin5a_d13	Video Input 5 Port A Data input ⁽²⁾	I	G16
vin5a_d14	Video Input 5 Port A Data input ⁽²⁾	I	A21
vin5a_d15	Video Input 5 Port A Data input ⁽²⁾	I	C18
Video Input 6			
vin6a_clk0	Video Input 6 Port A Clock input ⁽²⁾	I	E17
vin6a_de0	Video Input 6 Port B Data Enable input ⁽²⁾	I	D14
vin6a_fid0	Video Input 6 Port A Field ID input ⁽²⁾	I	C14
vin6a_hsync0	Video Input 6 Port A Horizontal Sync input ⁽²⁾	I	F12

表 4-4. VIP Signal Descriptions (continued)

SIGNAL NAME	DESCRIPTION	TYPE	BALL
vin6a_vsync0	Video Input 6 Port A Vertical Sync input ⁽²⁾	I	G12
vin6a_d0	Video Input 6 Port A Data input ⁽²⁾	I	C17 / D18
vin6a_d1	Video Input 6 Port A Data input ⁽²⁾	I	B19
vin6a_d2	Video Input 6 Port A Data input ⁽²⁾	I	F15
vin6a_d3	Video Input 6 Port A Data input ⁽²⁾	I	B18
vin6a_d4	Video Input 6 Port A Data input ⁽²⁾	I	A16
vin6a_d5	Video Input 6 Port A Data input ⁽²⁾	I	C15
vin6a_d6	Video Input 6 Port A Data input ⁽²⁾	I	A18
vin6a_d7	Video Input 6 Port A Data input ⁽²⁾	I	A19
vin6a_d8	Video Input 6 Port A Data input ⁽²⁾	I	F14
vin6a_d9	Video Input 6 Port A Data input ⁽²⁾	I	G14
vin6a_d10	Video Input 6 Port A Data input ⁽²⁾	I	A13
vin6a_d11	Video Input 6 Port A Data input ⁽²⁾	I	E14
vin6a_d12	Video Input 6 Port A Data input ⁽²⁾	I	A12
vin6a_d13	Video Input 6 Port A Data input ⁽²⁾	I	B13
vin6a_d14	Video Input 6 Port A Data input ⁽²⁾	I	A11
vin6a_d15	Video Input 6 Port A Data input ⁽²⁾	I	B12

(1) The VIP1 interface (Video Input 1a and Video Input 1b in 表 4-4) signal sets **are NOT supported in the DRA74x device**. For more details on the device differentiation, refer to the 表 3-1, *Device Comparison*.

(2) The VIP3 interface (Video Input 5 and Video Input 6 in 表 4-4) signal sets **are NOT supported in the DRA74x device**. For more details on the device differentiation, refer to the 表 3-1, *Device Comparison*.

4.4.2 Display Subsystem – Video Output Ports

注意

The I/O timings provided in 7, *Timing Requirements and Switching Characteristics* are valid only if signals within a single IOSET are used. The IOSETs are defined in the 表 7-19 and 表 7-20.

表 4-5. DSS Signal Descriptions

SIGNAL NAME	DESCRIPTION	TYPE	BALL
DPI Video Output 1			
vout1_clk	Video Output 1 Clock output	O	D11
vout1_de	Video Output 1 Data Enable output	O	B10
vout1_fid	Video Output 1 Field ID output. This signal is not used for embedded sync modes.	O	B11
vout1_hsync	Video Output 1 Horizontal Sync output. This signal is not used for embedded sync modes.	O	C11
vout1_vsync	Video Output 1 Vertical Sync output. This signal is not used for embedded sync modes.	O	E11
vout1_d0	Video Output 1 Data output	O	F11
vout1_d1	Video Output 1 Data output	O	G10
vout1_d2	Video Output 1 Data output	O	F10
vout1_d3	Video Output 1 Data output	O	G11
vout1_d4	Video Output 1 Data output	O	E9
vout1_d5	Video Output 1 Data output	O	F9
vout1_d6	Video Output 1 Data output	O	F8
vout1_d7	Video Output 1 Data output	O	E7
vout1_d8	Video Output 1 Data output	O	E8

表 4-5. DSS Signal Descriptions (continued)

SIGNAL NAME	DESCRIPTION	TYPE	BALL
vout1_d9	Video Output 1 Data output	O	D9
vout1_d10	Video Output 1 Data output	O	D7
vout1_d11	Video Output 1 Data output	O	D8
vout1_d12	Video Output 1 Data output	O	A5
vout1_d13	Video Output 1 Data output	O	C6
vout1_d14	Video Output 1 Data output	O	C8
vout1_d15	Video Output 1 Data output	O	C7
vout1_d16	Video Output 1 Data output	O	B7
vout1_d17	Video Output 1 Data output	O	B8
vout1_d18	Video Output 1 Data output	O	A7
vout1_d19	Video Output 1 Data output	O	A8
vout1_d20	Video Output 1 Data output	O	C9
vout1_d21	Video Output 1 Data output	O	A9
vout1_d22	Video Output 1 Data output	O	B9
vout1_d23	Video Output 1 Data output	O	A10
DPI Video Output 2			
vout2_clk	Video Output 2 Clock output	O	H7 / B26
vout2_de	Video Output 2 Data Enable output	O	G2 / C23
vout2_fid	Video Output 2 Field ID output. This signal is not used for embedded sync modes.	O	E1 / F21
vout2_hsync	Video Output 2 Horizontal Sync output. This signal is not used for embedded sync modes.	O	G1 / E21
vout2_vsync	Video Output 2 Vertical Sync output. This signal is not used for embedded sync modes.	O	G6 / F20
vout2_d0	Video Output 2 Data output	O	A4 / B14
vout2_d1	Video Output 2 Data output	O	B5 / J14
vout2_d2	Video Output 2 Data output	O	B4 / G13
vout2_d3	Video Output 2 Data output	O	B3 / J11
vout2_d4	Video Output 2 Data output	O	A3 / E12
vout2_d5	Video Output 2 Data output	O	C5 / F13
vout2_d6	Video Output 2 Data output	O	D6 / C12
vout2_d7	Video Output 2 Data output	O	B2 / D12
vout2_d8	Video Output 2 Data output	O	C4 / E15
vout2_d9	Video Output 2 Data output	O	C3 / A20
vout2_d10	Video Output 2 Data output	O	C2 / B15
vout2_d11	Video Output 2 Data output	O	D5 / A15
vout2_d12	Video Output 2 Data output	O	F6 / D15
vout2_d13	Video Output 2 Data output	O	D3 / B16
vout2_d14	Video Output 2 Data output	O	E6 / B17
vout2_d15	Video Output 2 Data output	O	F5 / A17
vout2_d16	Video Output 2 Data output	O	E4 / C18
vout2_d17	Video Output 2 Data output	O	C1 / A21
vout2_d18	Video Output 2 Data output	O	F4 / G16
vout2_d19	Video Output 2 Data output	O	D2 / D17
vout2_d20	Video Output 2 Data output	O	E2 / AA3
vout2_d21	Video Output 2 Data output	O	D1 / AB9
vout2_d22	Video Output 2 Data output	O	F3 / AB3
vout2_d23	Video Output 2 Data output	O	F2 / AA4
DPI Video Output 3			
vout3_clk	Video Output 3 Clock output	O	P1 / AF9 ⁽¹⁾

表 4-5. DSS Signal Descriptions (continued)

SIGNAL NAME	DESCRIPTION	TYPE	BALL
vout3_de	Video Output 3 Data Enable output	O	N9 / AD9 ⁽¹⁾
vout3_fld	Video Output 3 Field ID output. This signal is not used for embedded sync modes.	O	P9 / AG8 ⁽¹⁾
vout3_hsync	Video Output 3 Horizontal Sync output. This signal is not used for embedded sync modes.	O	N7 / AE9 ⁽¹⁾
vout3_vsync	Video Output 3 Vertical Sync output. This signal is not used for embedded sync modes.	O	R4 / AF8 ⁽¹⁾
vout3_d0	Video Output 3 Data output	O	M6/ AH4 ⁽¹⁾ / AD3 ⁽¹⁾
vout3_d1	Video Output 3 Data output	O	M2/ AG6 ⁽¹⁾ / AD2 ⁽¹⁾
vout3_d2	Video Output 3 Data output	O	L5/ AH5 ⁽¹⁾ / AE6 ⁽¹⁾
vout3_d3	Video Output 3 Data output	O	M1/ AH3 ⁽¹⁾ / AE2 ⁽¹⁾
vout3_d4	Video Output 3 Data output	O	L6/ AH6 ⁽¹⁾ / AE1 ⁽¹⁾
vout3_d5	Video Output 3 Data output	O	L4/ AG7 ⁽¹⁾ / AE5 ⁽¹⁾
vout3_d6	Video Output 3 Data output	O	L3/ AD8 ⁽¹⁾ / AE3 ⁽¹⁾
vout3_d7	Video Output 3 Data output	O	L2/ AE8 ⁽¹⁾ / AF1 ⁽¹⁾
vout3_d8	Video Output 3 Data output	O	L1 / AF4 ⁽¹⁾
vout3_d9	Video Output 3 Data output	O	K2 / AF3 ⁽¹⁾
vout3_d10	Video Output 3 Data output	O	J1 / AF6 ⁽¹⁾
vout3_d11	Video Output 3 Data output	O	J2 / AF2 ⁽¹⁾
vout3_d12	Video Output 3 Data output	O	H1 / AG5 ⁽¹⁾
vout3_d13	Video Output 3 Data output	O	J3 / AG3 ⁽¹⁾
vout3_d14	Video Output 3 Data output	O	H2 / AG2 ⁽¹⁾
vout3_d15	Video Output 3 Data output	O	H3 / AG4 ⁽¹⁾
vout3_d16	Video Output 3 Data output	O	R6/ AG8 ⁽¹⁾ / AH4 ⁽¹⁾
vout3_d17	Video Output 3 Data output	O	T9/ AD9 ⁽¹⁾ / AG6 ⁽¹⁾
vout3_d18	Video Output 3 Data output	O	T6 / AH5 ⁽¹⁾
vout3_d19	Video Output 3 Data output	O	T7 / AH3 ⁽¹⁾
vout3_d20	Video Output 3 Data output	O	P6 / AH6 ⁽¹⁾
vout3_d21	Video Output 3 Data output	O	R9 / AG7 ⁽¹⁾
vout3_d22	Video Output 3 Data output	O	R5 / AD8 ⁽¹⁾
vout3_d23	Video Output 3 Data output	O	P5 / AE8 ⁽¹⁾

(1) The VOUT3 interface when multiplexed onto balls mapped to the VDDSHV6 supply rail is restricted to operating in 1.8V mode only (VDDSHV6 must be supplied with 1.8V). 3.3V mode is not supported. This must be considered in the pin mux programming and VDDSHVx supply connections.

4.4.3 Display Subsystem – High-Definition Multimedia Interface (HDMI)

注: For more information, see the Display Subsystem / Display Subsystem Overview of the device TRM.

表 4-6. HDMI Signal Descriptions

SIGNAL NAME	DESCRIPTION	TYPE	BALL
hdmi1_cec	HDMI consumer electronic control	IOD	B20/ G19
hdmi1_hpd	HDMI display hot plug detect	I	B21/ G20
hdmi1_ddc_scl	HDMI display data channel clock	IOD	C25
hdmi1_ddc_sda	HDMI display data channel data	IOD	F17

表 4-6. HDMI Signal Descriptions (continued)

SIGNAL NAME	DESCRIPTION	TYPE	BALL
hdmi1_clockx	HDMI clock differential positive or negative	ODS	AG16
hdmi1_clocky	HDMI clock differential positive or negative	ODS	AH16
hdmi1_data2x	HDMI data 2 differential positive or negative	ODS	AG19
hdmi1_data2y	HDMI data 2 differential positive or negative	ODS	AH19
hdmi1_data1x	HDMI data 1 differential positive or negative	ODS	AG18
hdmi1_data1y	HDMI data 1 differential positive or negative	ODS	AH18
hdmi1_data0x	HDMI data 0 differential positive or negative	ODS	AG17
hdmi1_data0y	HDMI data 0 differential positive or negative	ODS	AH17

4.4.4 External Memory Interface (EMIF)

注: For more information, see the Memory Subsystem / EMIF Controller section of the device TRM.

注: The index numbers 1 and 2 which are part of the EMIF1 and EMIF2 signal prefixes (ddr1_* and ddr2_*) listed in 表 4-7, EMIF Signal Descriptions, not to be confused with DDR1 and DDR2 types of SDRAM memories.

表 4-7. EMIF Signal Descriptions

SIGNAL NAME	DESCRIPTION	TYPE	BALL
EMIF Channel 1			
ddr1_csn0	EMIF1 Chip Select 0	O	AH23
ddr1_cke	EMIF1 Clock Enable	O	AG22
ddr1_ck	EMIF1 Clock	O	AG24
ddr1_nck	EMIF1 Negative Clock	O	AH24
ddr1_odt0	EMIF1 On-Die Termination for Chip Select 0	O	AE20
ddr1_casn	EMIF1 Column Address Strobe	O	AC18
ddr1_rasn	EMIF1 Row Address Strobe	O	AF20
ddr1_wen	EMIF1 Write Enable	O	AH21
ddr1_rst	EMIF1 Reset output (DDR3-SDRAM only)	O	AG21
ddr1_ba0	EMIF1 Bank Address	O	AF17
ddr1_ba1	EMIF1 Bank Address	O	AE18
ddr1_ba2	EMIF1 Bank Address	O	AB18
ddr1_a0	EMIF1 Address Bus	O	AD20
ddr1_a1	EMIF1 Address Bus	O	AC19
ddr1_a2	EMIF1 Address Bus	O	AC20
ddr1_a3	EMIF1 Address Bus	O	AB19
ddr1_a4	EMIF1 Address Bus	O	AF21
ddr1_a5	EMIF1 Address Bus	O	AH22
ddr1_a6	EMIF1 Address Bus	O	AG23
ddr1_a7	EMIF1 Address Bus	O	AE21
ddr1_a8	EMIF1 Address Bus	O	AF22
ddr1_a9	EMIF1 Address Bus	O	AE22
ddr1_a10	EMIF1 Address Bus	O	AD21
ddr1_a11	EMIF1 Address Bus	O	AD22
ddr1_a12	EMIF1 Address Bus	O	AC21

表 4-7. EMIF Signal Descriptions (continued)

SIGNAL NAME	DESCRIPTION	TYPE	BALL
ddr1_a13	EMIF1 Address Bus	O	AF18
ddr1_a14	EMIF1 Address Bus	O	AE17
ddr1_a15	EMIF1 Address Bus	O	AD18
ddr1_d0	EMIF1 Data Bus	IO	AF25
ddr1_d1	EMIF1 Data Bus	IO	AF26
ddr1_d2	EMIF1 Data Bus	IO	AG26
ddr1_d3	EMIF1 Data Bus	IO	AH26
ddr1_d4	EMIF1 Data Bus	IO	AF24
ddr1_d5	EMIF1 Data Bus	IO	AE24
ddr1_d6	EMIF1 Data Bus	IO	AF23
ddr1_d7	EMIF1 Data Bus	IO	AE23
ddr1_d8	EMIF1 Data Bus	IO	AC23
ddr1_d9	EMIF1 Data Bus	IO	AF27
ddr1_d10	EMIF1 Data Bus	IO	AG27
ddr1_d11	EMIF1 Data Bus	IO	AF28
ddr1_d12	EMIF1 Data Bus	IO	AE26
ddr1_d13	EMIF1 Data Bus	IO	AC25
ddr1_d14	EMIF1 Data Bus	IO	AC24
ddr1_d15	EMIF1 Data Bus	IO	AD25
ddr1_d16	EMIF1 Data Bus	IO	V20
ddr1_d17	EMIF1 Data Bus	IO	W20
ddr1_d18	EMIF1 Data Bus	IO	AB28
ddr1_d19	EMIF1 Data Bus	IO	AC28
ddr1_d20	EMIF1 Data Bus	IO	AC27
ddr1_d21	EMIF1 Data Bus	IO	Y19
ddr1_d22	EMIF1 Data Bus	IO	AB27
ddr1_d23	EMIF1 Data Bus	IO	Y20
ddr1_d24	EMIF1 Data Bus	IO	AA23
ddr1_d25	EMIF1 Data Bus	IO	Y22
ddr1_d26	EMIF1 Data Bus	IO	Y23
ddr1_d27	EMIF1 Data Bus	IO	AA24
ddr1_d28	EMIF1 Data Bus	IO	Y24
ddr1_d29	EMIF1 Data Bus	IO	AA26
ddr1_d30	EMIF1 Data Bus	IO	AA25
ddr1_d31	EMIF1 Data Bus	IO	AA28
ddr1_ecc_d0	EMIF1 ECC Data Bus ⁽¹⁾	IO	W22
ddr1_ecc_d1	EMIF1 ECC Data Bus ⁽¹⁾	IO	V23
ddr1_ecc_d2	EMIF1 ECC Data Bus ⁽¹⁾	IO	W19
ddr1_ecc_d3	EMIF1 ECC Data Bus ⁽¹⁾	IO	W23
ddr1_ecc_d4	EMIF1 ECC Data Bus ⁽¹⁾	IO	Y25
ddr1_ecc_d5	EMIF1 ECC Data Bus ⁽¹⁾	IO	V24
ddr1_ecc_d6	EMIF1 ECC Data Bus ⁽¹⁾	IO	V25
ddr1_ecc_d7	EMIF1 ECC Data Bus ⁽¹⁾	IO	Y26
ddr1_dqm0	EMIF1 Data Mask	O	AD23
ddr1_dqm1	EMIF1 Data Mask	O	AB23
ddr1_dqm2	EMIF1 Data Mask	O	AC26
ddr1_dqm3	EMIF1 Data Mask	O	AA27

表 4-7. EMIF Signal Descriptions (continued)

SIGNAL NAME	DESCRIPTION	TYPE	BALL
ddr1_dqm_ecc	EMIF1 ECC Data Mask	O	V26
ddr1_dqs0	Data strobe 0 input/output for byte 0 of the 32-bit data bus. This signal is output to the EMIF1 memory when writing and input when reading.	IO	AH25
ddr1_dqsn0	Data strobe 0 invert	IO	AG25
ddr1_dqs1	Data strobe 1 input/output for byte 1 of the 32-bit data bus. This signal is output to the EMIF1 memory when writing and input when reading.	IO	AE27
ddr1_dqsn1	Data strobe 1 invert	IO	AE28
ddr1_dqs2	Data strobe 2 input/output for byte 2 of the 32-bit data bus. This signal is output to the EMIF1 memory when writing and input when reading.	IO	AD27
ddr1_dqsn2	Data strobe 2 invert	IO	AD28
ddr1_dqs3	Data strobe 3 input/output for byte 3 of the 32-bit data bus. This signal is output to the EMIF1 memory when writing and input when reading.	IO	Y28
ddr1_dqsn3	Data strobe 3 invert	IO	Y27
ddr1_dqs_ecc	EMIF1 ECC Data strobe input/output. This signal is output to the EMIF1 memory when writing and input when reading.	IO	V27
ddr1_dqsn_ecc	EMIF1 ECC Complementary Data strobe	IO	V28
ddr1_vref0	Reference Power Supply EMIF1	A	Y18
EMIF Channel 2			
ddr2_csn0	EMIF2 Chip Select 0	O	P24
ddr2_cke	EMIF2 Clock Enable	O	U24
ddr2_ck	EMIF2 Clock	O	T28
ddr2_nck	EMIF2 Negative Clock	O	T27
ddr2_odt0	EMIF2 On-Die Termination for Chip Select 0	O	R23
ddr2_casn	EMIF2 Column Address Strobe	O	U28
ddr2_rasn	EMIF2 Row Address Strobe	O	T23
ddr2_wen	EMIF2 Write Enable	O	U25
ddr2_rst	EMIF2 Reset output (DDR3-SDRAM only)	O	R24
ddr2_ba0	EMIF2 Bank Address	O	U23
ddr2_ba1	EMIF2 Bank Address	O	U27
ddr2_ba2	EMIF2 Bank Address	O	U26
ddr2_a0	EMIF2 Address Bus	O	R25
ddr2_a1	EMIF2 Address Bus	O	R26
ddr2_a2	EMIF2 Address Bus	O	R28
ddr2_a3	EMIF2 Address Bus	O	R27
ddr2_a4	EMIF2 Address Bus	O	P23
ddr2_a5	EMIF2 Address Bus	O	P22
ddr2_a6	EMIF2 Address Bus	O	P25
ddr2_a7	EMIF2 Address Bus	O	N20
ddr2_a8	EMIF2 Address Bus	O	P27
ddr2_a9	EMIF2 Address Bus	O	N27
ddr2_a10	EMIF2 Address Bus	O	N23
ddr2_a11	EMIF2 Address Bus	O	P26
ddr2_a12	EMIF2 Address Bus	O	N28
ddr2_a13	EMIF2 Address Bus	O	T22
ddr2_a14	EMIF2 Address Bus	O	R22
ddr2_a15	EMIF2 Address Bus	O	U22
ddr2_d0	EMIF2 Data Bus	IO	E26
ddr2_d1	EMIF2 Data Bus	IO	G25
ddr2_d2	EMIF2 Data Bus	IO	F25

表 4-7. EMIF Signal Descriptions (continued)

SIGNAL NAME	DESCRIPTION	TYPE	BALL
ddr2_d3	EMIF2 Data Bus	IO	F24
ddr2_d4	EMIF2 Data Bus	IO	F26
ddr2_d5	EMIF2 Data Bus	IO	F27
ddr2_d6	EMIF2 Data Bus	IO	E27
ddr2_d7	EMIF2 Data Bus	IO	E28
ddr2_d8	EMIF2 Data Bus	IO	H23
ddr2_d9	EMIF2 Data Bus	IO	H25
ddr2_d10	EMIF2 Data Bus	IO	H24
ddr2_d11	EMIF2 Data Bus	IO	H26
ddr2_d12	EMIF2 Data Bus	IO	G26
ddr2_d13	EMIF2 Data Bus	IO	J25
ddr2_d14	EMIF2 Data Bus	IO	J26
ddr2_d15	EMIF2 Data Bus	IO	J24
ddr2_d16	EMIF2 Data Bus	IO	L22
ddr2_d17	EMIF2 Data Bus	IO	K20
ddr2_d18	EMIF2 Data Bus	IO	K21
ddr2_d19	EMIF2 Data Bus	IO	L23
ddr2_d20	EMIF2 Data Bus	IO	L24
ddr2_d21	EMIF2 Data Bus	IO	J23
ddr2_d22	EMIF2 Data Bus	IO	K22
ddr2_d23	EMIF2 Data Bus	IO	J20
ddr2_d24	EMIF2 Data Bus	IO	L27
ddr2_d25	EMIF2 Data Bus	IO	L26
ddr2_d26	EMIF2 Data Bus	IO	L25
ddr2_d27	EMIF2 Data Bus	IO	L28
ddr2_d28	EMIF2 Data Bus	IO	M23
ddr2_d29	EMIF2 Data Bus	IO	M24
ddr2_d30	EMIF2 Data Bus	IO	M25
ddr2_d31	EMIF2 Data Bus	IO	M26
ddr2_dqm0	EMIF2 Data Mask	O	F28
ddr2_dqm1	EMIF2 Data Mask	O	G24
ddr2_dqm2	EMIF2 Data Mask	O	K23
ddr2_dqm3	EMIF2 Data Mask	O	M22
ddr2_dqs0	Data strobe 0 input/output for byte 0 of the 32-bit data bus. This signal is output to the EMIF2 memory when writing and input when reading.	IO	G28
ddr2_dqsn0	Data strobe 0 invert	IO	G27
ddr2_dqs1	Data strobe 1 input/output for byte 1 of the 32-bit data bus. This signal is output to the EMIF2 memory when writing and input when reading.	IO	H27
ddr2_dqsn1	Data strobe 1 invert	IO	H28
ddr2_dqs2	Data strobe 2 input/output for byte 2 of the 32-bit data bus. This signal is output to the EMIF2 memory when writing and input when reading.	IO	K27
ddr2_dqsn2	Data strobe 2 invert	IO	K28
ddr2_dqs3	Data strobe 3 input/output for byte 3 of the 32-bit data bus. This signal is output to the EMIF2 memory when writing and input when reading.	IO	M28
ddr2_dqsn3	Data strobe 3 invert	IO	M27
ddr2_vref0	Reference Power Supply EMIF2	A	N22

(1) The ECC module (EMIF1 ECC Data Bus in 表 4-4) signal sets are NOT supported in the DRA74x device. For more details on the device differentiation, refer to the 表 3-1, *Device Comparison*.

4.4.5 General-Purpose Memory Controller (GPMC)

注: For more information, see the Memory Subsystem / General-Purpose Memory Controller section of the device TRM.

表 4-8. GPMC Signal Descriptions

SIGNAL NAME	DESCRIPTION	TYPE	BALL
gpmc_ad0	GPMC Data 0 in A/D nonmultiplexed mode and additionally Address 1 in A/D multiplexed mode	IO	M6
gpmc_ad1	GPMC Data 1 in A/D nonmultiplexed mode and additionally Address 2 in A/D multiplexed mode	IO	M2
gpmc_ad2	GPMC Data 2 in A/D nonmultiplexed mode and additionally Address 3 in A/D multiplexed mode	IO	L5
gpmc_ad3	GPMC Data 3 in A/D nonmultiplexed mode and additionally Address 4 in A/D multiplexed mode	IO	M1
gpmc_ad4	GPMC Data 4 in A/D nonmultiplexed mode and additionally Address 5 in A/D multiplexed mode	IO	L6
gpmc_ad5	GPMC Data 5 in A/D nonmultiplexed mode and additionally Address 6 in A/D multiplexed mode	IO	L4
gpmc_ad6	GPMC Data 6 in A/D nonmultiplexed mode and additionally Address 7 in A/D multiplexed mode	IO	L3
gpmc_ad7	GPMC Data 7 in A/D nonmultiplexed mode and additionally Address 8 in A/D multiplexed mode	IO	L2
gpmc_ad8	GPMC Data 8 in A/D nonmultiplexed mode and additionally Address 9 in A/D multiplexed mode	IO	L1
gpmc_ad9	GPMC Data 9 in A/D nonmultiplexed mode and additionally Address 10 in A/D multiplexed mode	IO	K2
gpmc_ad10	GPMC Data 10 in A/D nonmultiplexed mode and additionally Address 11 in A/D multiplexed mode	IO	J1
gpmc_ad11	GPMC Data 11 in A/D nonmultiplexed mode and additionally Address 12 in A/D multiplexed mode	IO	J2
gpmc_ad12	GPMC Data 12 in A/D nonmultiplexed mode and additionally Address 13 in A/D multiplexed mode	IO	H1
gpmc_ad13	GPMC Data 13 in A/D nonmultiplexed mode and additionally Address 14 in A/D multiplexed mode	IO	J3
gpmc_ad14	GPMC Data 14 in A/D nonmultiplexed mode and additionally Address 15 in A/D multiplexed mode	IO	H2
gpmc_ad15	GPMC Data 15 in A/D nonmultiplexed mode and additionally Address 16 in A/D multiplexed mode	IO	H3
gpmc_a0	GPMC Address 0. Only used to effectively address 8-bit data nonmultiplexed memories	O	R6 / P4
gpmc_a1	GPMC address 1 in A/D nonmultiplexed mode and Address 17 in A/D multiplexed mode	O	T9 / P1
gpmc_a2	GPMC address 2 in A/D nonmultiplexed mode and Address 18 in A/D multiplexed mode	O	T6 / N1
gpmc_a3	GPMC address 3 in A/D nonmultiplexed mode and Address 19 in A/D multiplexed mode	O	T7 / M4
gpmc_a4	GPMC address 4 in A/D nonmultiplexed mode and Address 20 in A/D multiplexed mode	O	P6
gpmc_a5	GPMC address 5 in A/D nonmultiplexed mode and Address 21 in A/D multiplexed mode	O	R9
gpmc_a6	GPMC address 6 in A/D nonmultiplexed mode and Address 22 in A/D multiplexed mode	O	R5

表 4-8. GPMC Signal Descriptions (continued)

SIGNAL NAME	DESCRIPTION	TYPE	BALL
gpmc_a7	GPMC address 7 in A/D nonmultiplexed mode and Address 23 in A/D multiplexed mode	O	P5
gpmc_a8	GPMC address 8 in A/D nonmultiplexed mode and Address 24 in A/D multiplexed mode	O	N7
gpmc_a9	GPMC address 9 in A/D nonmultiplexed mode and Address 25 in A/D multiplexed mode	O	R4
gpmc_a10	GPMC address 10 in A/D nonmultiplexed mode and Address 26 in A/D multiplexed mode	O	N9
gpmc_a11	GPMC address 11 in A/D nonmultiplexed mode and unused in A/D multiplexed mode	O	P9
gpmc_a12	GPMC address 12 in A/D nonmultiplexed mode and unused in A/D multiplexed mode	O	P4
gpmc_a13	GPMC address 13 in A/D nonmultiplexed mode and unused in A/D multiplexed mode	O	R3 / K7
gpmc_a14	GPMC address 14 in A/D nonmultiplexed mode and unused in A/D multiplexed mode	O	T2 / M7
gpmc_a15	GPMC address 15 in A/D nonmultiplexed mode and unused in A/D multiplexed mode	O	U2 / J5
gpmc_a16	GPMC address 16 in A/D nonmultiplexed mode and unused in A/D multiplexed mode	O	U1 / K6
gpmc_a17	GPMC address 17 in A/D nonmultiplexed mode and unused in A/D multiplexed mode	O	P3 / J7
gpmc_a18	GPMC address 18 in A/D nonmultiplexed mode and unused in A/D multiplexed mode	O	R2 / J4
gpmc_a19	GPMC address 19 in A/D nonmultiplexed mode and unused in A/D multiplexed mode	O	K7 ⁽³⁾ / J6
gpmc_a20	GPMC address 20 in A/D nonmultiplexed mode and unused in A/D multiplexed mode	O	M7 ⁽³⁾ / H4
gpmc_a21	GPMC address 21 in A/D nonmultiplexed mode and unused in A/D multiplexed mode	O	J5 ⁽³⁾ / H5
gpmc_a22	GPMC address 22 in A/D nonmultiplexed mode and unused in A/D multiplexed mode	O	K6 ⁽³⁾ / H6
gpmc_a23	GPMC address 23 in A/D nonmultiplexed mode and unused in A/D multiplexed mode	O	J7/ AG5/ N1
gpmc_a24	GPMC address 24 in A/D nonmultiplexed mode and unused in A/D multiplexed mode	O	J4 ⁽³⁾ / AF2
gpmc_a25	GPMC address 25 in A/D nonmultiplexed mode and unused in A/D multiplexed mode	O	J6 ⁽³⁾ / AF6
gpmc_a26	GPMC address 26 in A/D nonmultiplexed mode and unused in A/D multiplexed mode	O	H4 ⁽³⁾ / AF3
gpmc_a27	GPMC address 27 in A/D nonmultiplexed mode and Address 27 in A/D multiplexed mode	O	H5 ⁽³⁾ / AF4
gpmc_cs0	GPMC Chip Select 0 (active low)	O	T1
gpmc_cs1	GPMC Chip Select 1 (active low)	O	H6
gpmc_cs2	GPMC Chip Select 2 (active low)	O	P2
gpmc_cs3	GPMC Chip Select 3 (active low)	O	P1
gpmc_cs4	GPMC Chip Select 4 (active low)	O	N6
gpmc_cs5	GPMC Chip Select 5 (active low)	O	M4
gpmc_cs6	GPMC Chip Select 6 (active low)	O	N1
gpmc_cs7	GPMC Chip Select 7 (active low)	O	P7
gpmc_clk ⁽¹⁾⁽²⁾	GPMC Clock output	IO	P7
gpmc_advn_ale	GPMC address valid active low or address latch enable	O	N1
gpmc_oen_ren	GPMC output enable active low or read enable	O	M5
gpmc_wen	GPMC write enable active low	O	M3

表 4-8. GPMC Signal Descriptions (continued)

SIGNAL NAME	DESCRIPTION	TYPE	BALL
gpmc_ben0	GPMC lower-byte enable active low	O	N6
gpmc_ben1	GPMC upper-byte enable active low	O	M4
gpmc_wait0	GPMC external indication of wait 0	I	N2
gpmc_wait1	GPMC external indication of wait 1	I	P7 / N1

- (1) This clock signal is implemented as 'pad loopback' inside the device - the output signal is looped back through the input buffer to serve as the internal reference signal. Series termination is recommended (as close to device pin as possible) to improve signal integrity of the clock input. Any nonmonotonicity in voltage that occurs at the pad loopback clock pin between V_{IH} and V_{IL} must be less than V_{HYS} .
- (2) The gpio6_16.clkout1 signal can be used as an "always-on" alternative to gpmc_clk provided that the external device can support the associated timing. See 表 7-26 *GPMC/NOR Flash Interface Switching Characteristics - Synchronous Mode - Default* and 表 7-28 *GPMC/NOR Flash Interface Switching Characteristics - Synchronous Mode - Alternate* for timing information.
- (3) The internal pull resistors for balls K7, M7, J5, K6, J4, J6, H4, H5 are permanently disabled when sysboot15 is set to 1 as described in the section *Sysboot Configuration* of the Device TRM. If internal pull-up/down resistors are desired on these balls then sysboot15 should be set to 0. If gpmc boot mode is used with SYSBOOT15=1 (not recommended) then external pull-downs should be implemented to keep the address bus at logic-0 value during boot since the gpmc ms-address bits are high-z during boot.

4.4.6 Timers

注: For more information, see the Timers section of the device TRM.

表 4-9. Timers Signal Descriptions

SIGNAL NAME	DESCRIPTION	TYPE	BALL
timer1	PWM output/event trigger input	IO	M4 / E21
timer2	PWM output/event trigger input	IO	N6 / F20
timer3	PWM output/event trigger input	IO	N1 / F21
timer4	PWM output/event trigger input	IO	P7 / D12
timer5	PWM output/event trigger input	IO	U2 / B12
timer6	PWM output/event trigger input	IO	T2 / A11
timer7	PWM output/event trigger input	IO	R3 / B13
timer8	PWM output/event trigger input	IO	P4 / A12
timer9	PWM output/event trigger input	IO	P9 / E14
timer10	PWM output/event trigger input	IO	N9 / A13
timer11	PWM output/event trigger input	IO	R4 / G14
timer12	PWM output/event trigger input	IO	N7 / F14
timer13	PWM output/event trigger input	IO	D18 / AF8
timer14	PWM output/event trigger input	IO	E17 / AE9
timer15	PWM output/event trigger input	IO	B26 / AF9 / AC10
timer16	PWM output/event trigger input	IO	C23 / AD9 / AB10

4.4.7 Inter-Integrated Circuit Interface (I²C)

注: For more information, see the Serial Communication Interface / Multimaster High-Speed I2C Controller / HS I2C Environment / HS I2C in I2C Mode section of the device TRM.

注: I²C1 and I²C2 do NOT support HS-mode.

表 4-10. I²C Signal Descriptions

SIGNAL NAME	DESCRIPTION	TYPE	BALL
Inter-Integrated Circuit Interface (I2C1)			
i2c1_scl	I2C1 Clock	IOD	C20
i2c1_sda	I2C1 Data	IOD	C21
Inter-Integrated Circuit Interface (I2C2)			
i2c2_scl	I2C2 Clock	IOD	F17
i2c2_sda	I2C2 Data	IOD	C25
Inter-Integrated Circuit Interface (I2C3)			
i2c3_scl	I2C3 Clock	IOD	P7/ D14/ AB4/ F20
i2c3_sda	I2C3 Data	IOD	N1/ C14/ AC5/ E21
Inter-Integrated Circuit Interface (I2C4)			
i2c4_scl	I2C4 Clock	IOD	R6/ J14/ A21/ Y9
i2c4_sda	I2C4 Data	IOD	T9/ B14/ C18/ W7
Inter-Integrated Circuit Interface (I2C5)			
i2c5_scl	I2C5 Clock	IOD	AB9/ P6/ F12
i2c5_sda	I2C5 Data	IOD	AA3/ R9/ G12

4.4.8 HDQ / 1-Wire Interface (HDQ1W)

注: For more information, see the Serial Communication Interface / HDQ/1-Wire section of the device TRM.

表 4-11. HDQ / 1-Wire Signal Descriptions

SIGNAL NAME	DESCRIPTION	TYPE	BALL
hdq0	HDQ or 1-wire protocol single interface pin	IOD	D18/ C23

4.4.9 Universal Asynchronous Receiver Transmitter (UART)

注: For more information see the Serial Communication Interface /UART/IrDA/CIR section of the device TRM.

表 4-12. UART Signal Descriptions

SIGNAL NAME	DESCRIPTION	TYPE	BALL
Universal Asynchronous Receiver/Transmitter (UART1)			
uart1_dcdn	UART1 Data Carrier Detect active low	I	D28
uart1_dsrn	UART1 Data Set Ready Active Low	I	D26
uart1_dtrn	UART1 Data Terminal Ready Active Low	O	D27
uart1_rin	UART1 Ring Indicator	I	C28
uart1_rxd	UART1 Receive Data	I	B27
uart1_txd	UART1 Transmit Data	O	C26
uart1_ctsn	UART1 clear to send active low	I	E25
uart1_rtsn	UART1 request to send active low	O	C27
Universal Asynchronous Receiver/Transmitter (UART2)			
uart2_rxd	UART2 Receive Data	I	D28
uart2_txd	UART2 Transmit Data	O	D26
uart2_ctsn	UART2 clear to send active low	I	D27
uart2_rtsn	UART2 request to send active low	O	C28

表 4-12. UART Signal Descriptions (continued)

SIGNAL NAME	DESCRIPTION	TYPE	BALL
Universal Asynchronous Receiver/Transmitter (UART3)/IrDA			
uart3_rxd	UART3 Receive Data for both normal UART mode and IrDA mode	I	V2/ AB3/ A26 / D27
uart3_txd	UART3 Transmit Data	O	Y1/ AA4/ B22/ C28
uart3_ctsn	UART3 clear to send active low	I	U4/ W9/ G17/ D28
uart3_rtsn	UART3 request to send active low	O	V1/ V9/ D28/ B24
uart3_rctx	Remote control data	O	D28
uart3_sd	Infrared transceiver configure/shutdown	O	D26
uart3_irtx	Infrared data output	O	C28
Universal Asynchronous Receiver/Transmitter (UART4)			
uart4_rxd	UART4 Receive Data	I	V7/ G16/ B21
uart4_txd	UART4 Transmit Data	O	U7/ D17/ B20
uart4_ctsn	UART4 clear to send active low	I	V6
uart4_rtsn	UART4 request to send active low	O	U6
Universal Asynchronous Receiver/Transmitter (UART5)			
uart5_rxd	UART5 Receive Data	I	R6/ F11/ B19/ AC7/ G17
uart5_txd	UART5 Transmit Data	O	T9/ G10/ C17/ AC6/ B24
uart5_ctsn	UART5 clear to send active low	I	T6 / AC9
uart5_rtsn	UART5 request to send active low	O	T7 / AC3
Universal Asynchronous Receiver/Transmitter (UART6)			
uart6_rxd	UART6 Receive Data	I	P6/ E8/ G12/ W7
uart6_txd	UART6 Transmit Data	O	R9/ D9/ F12/ Y9
uart6_ctsn	UART6 clear to send active low	I	R5 / G13
uart6_rtsn	UART6 request to send active low	O	P5 / J11
Universal Asynchronous Receiver/Transmitter (UART7)			
uart7_rxd	UART7 Receive Data	I	T6/ AD9/ B7/ B18
uart7_txd	UART7 Transmit Data	O	T7/ AF9/ B8/ F15
uart7_ctsn	UART7 clear to send active low	I	AE9 / B19
uart7_rtsn	UART7 request to send active low	O	AF8 / C17
Universal Asynchronous Receiver/Transmitter (UART8)			
uart8_rxd	UART8 Receive Data	I	AE8/ R5/ C18/ G20
uart8_txd	UART8 Transmit Data	O	AD8/ P5/ A21/ G19
uart8_ctsn	UART8 clear to send active low	I	AG7 / G16
uart8_rtsn	UART8 request to send active low	O	AH6 / D17
Universal Asynchronous Receiver/Transmitter (UART9)			
uart9_rxd	UART9 Receive Data	I	G1/ AA3/ E25
uart9_txd	UART9 Transmit Data	O	G6/ AB9/ C27
uart9_ctsn	UART9 clear to send active low	I	F2 / AB3
uart9_rtsn	UART9 request to send active low	O	F3/ AA4
Universal Asynchronous Receiver/Transmitter (UART10)			
uart10_rxd	UART10 Receive Data	I	D1/ E21/ AC8/ D27
uart10_txd	UART10 Transmit Data	O	E2/ F20/ AD6/ C28
uart10_ctsn	UART10 clear to send active low	I	D2 / AB8
uart10_rtsn	UART10 request to send active low	O	F4 / AB5

4.4.10 Multichannel Serial Peripheral Interface (McSPI)

注意

The I/O timings provided in 7, *Timing Requirements and Switching Characteristics* are applicable for all combinations of signals for SPI1 and SPI2. However, the timings are valid only for SPI3 and SPI4 if signals within a single IOSET are used. The IOSETS are defined in the 表 7-45.

注: For more information, see the Serial Communication Interface / Multichannel Serial Peripheral Interface (McSPI) section of the device TRM.

表 4-13. SPI Signal Descriptions

SIGNAL NAME	DESCRIPTION	TYPE	BALL
Serial Peripheral Interface 1			
spi1_sclk ⁽¹⁾	SPI1 Clock	IO	A25
spi1_d1	SPI1 Data. Can be configured as either MISO or MOSI.	IO	F16
spi1_d0	SPI1 Data. Can be configured as either MISO or MOSI.	IO	B25
spi1_cs0	SPI1 Chip Select	IO	A24
spi1_cs1	SPI1 Chip Select	IO	A22
spi1_cs2	SPI1 Chip Select	IO	B21
spi1_cs3	SPI1 Chip Select	IO	B20
Serial Peripheral Interface 2			
spi2_sclk ⁽¹⁾	SPI2 Clock	IO	A26
spi2_d1	SPI2 Data. Can be configured as either MISO or MOSI.	IO	B22
spi2_d0	SPI2 Data. Can be configured as either MISO or MOSI.	IO	G17
spi2_cs0	SPI2 Chip Select	IO	B24
spi2_cs1	SPI2 Chip Select	IO	A22
spi2_cs2	SPI2 Chip Select	IO	B21
spi2_cs3	SPI2 Chip Select	IO	B20
Serial Peripheral Interface 3			
spi3_sclk ⁽¹⁾	SPI3 Clock	IO	AD9/ V2/ B12/ E11/ AC4/ C18
spi3_d1	SPI3 Data. Can be configured as either MISO or MOSI.	IO	AF9/ Y1/ B10/ A11/ A21/ AC7
spi3_d0	SPI3 Data. Can be configured as either MISO or MOSI.	IO	AE9/ W9/ C11/ B13/ AC6/ G16
spi3_cs0	SPI3 Chip Select	IO	AF8/ V9/ D11/ A12/ AC9/ D17
spi3_cs1	SPI3 Chip Select	IO	B11/ AC3/ E14
spi3_cs2	SPI3 Chip Select	IO	F11
spi3_cs3	SPI3 Chip Select	IO	A10
Serial Peripheral Interface 4			
spi4_sclk ⁽¹⁾	SPI4 Clock	IO	N7/ G1/ AA3/ V7/ AC8
spi4_d1	SPI4 Data. Can be configured as either MISO or MOSI.	IO	R4/ G6/ AB9/ U7/ AD6
spi4_d0	SPI4 Data. Can be configured as either MISO or MOSI.	IO	N9/ F2/ AB3/ V6/ AB8
spi4_cs0	SPI4 Chip Select	IO	P9/ F3/ AA4/ U6/ AB5

表 4-13. SPI Signal Descriptions (continued)

SIGNAL NAME	DESCRIPTION	TYPE	BALL
spi4_cs1	SPI4 Chip Select	IO	P4 / Y1
spi4_cs2	SPI4 Chip Select	IO	R3 / W9
spi4_cs3	SPI4 Chip Select	IO	T2 / V9

(1) This clock signal is implemented as 'pad loopback' inside the device - the output signal is looped back through the input buffer to serve as the internal reference signal. Series termination is recommended (as close to device pin as possible) to improve signal integrity of the clock input. Any non-monotonicity in voltage that occurs at the pad loopback clock pin between V_{IH} and V_{IL} must be less than V_{HYS} .

4.4.11 Quad Serial Peripheral Interface (QSPI)

注: For more information see the Serial Communication Interface / Quad Serial Peripheral Interface section of the device TRM.

表 4-14. QSPI Signal Descriptions

SIGNAL NAME	DESCRIPTION	TYPE	BALL
qspi1_sclk	QSPI1 Serial Clock	O	R2
qspi1_rtclk	QSPI1 Return Clock Input. Must be connected from QSPI1_SCLK on PCB. Refer to PCB Guidelines for QSPI1	I	R3
qspi1_d0	QSPI1 Data[0]. This pin is output data for all commands/writes and for dual read and quad read modes it becomes input data pin during read phase.	IO	U1
qspi1_d1	QSPI1 Data[1]. Input read data in all modes	I	P3
qspi1_d2	QSPI1 Data[2]. This pin is used only in quad read mode as input data pin during read phase	I	U2
qspi1_d3	QSPI1 Data[3]. This pin is used only in quad read mode as input data pin during read phase	I	T2
qspi1_cs0	QSPI1 Chip Select[0]. This pin is Used for QSPI1 boot modes	O	P2
qspi1_cs1	QSPI1 Chip Select[1]	O	P1
qspi1_cs2	QSPI1 Chip Select[2]	O	T7
qspi1_cs3	QSPI1 Chip Select[3]	O	P6

4.4.12 Multichannel Audio Serial Port (McASP)

注: For more information, see the Serial Communication Interface / Multichannel Audio Serial Port (McASP) section of the device TRM.

表 4-15. McASP Signal Descriptions

SIGNAL NAME	DESCRIPTION	TYPE	BALL
Multichannel Audio Serial Port 1			
mcasep1_axr0	McASP1 Transmit/Receive Data	IO	G12
mcasep1_axr1	McASP1 Transmit/Receive Data	IO	F12
mcasep1_axr2	McASP1 Transmit/Receive Data	IO	G13
mcasep1_axr3	McASP1 Transmit/Receive Data	IO	J11
mcasep1_axr4	McASP1 Transmit/Receive Data	IO	D18/ E12
mcasep1_axr5	McASP1 Transmit/Receive Data	IO	E17 / F13
mcasep1_axr6	McASP1 Transmit/Receive Data	IO	B26 / C12
mcasep1_axr7	McASP1 Transmit/Receive Data	IO	C23 / D12
mcasep1_axr8	McASP1 Transmit/Receive Data	IO	E21 / B12
mcasep1_axr9	McASP1 Transmit/Receive Data	IO	F20/ A11
mcasep1_axr10	McASP1 Transmit/Receive Data	IO	F21 / B13

表 4-15. McASP Signal Descriptions (continued)

SIGNAL NAME	DESCRIPTION	TYPE	BALL
mcasp1_axr11	McASP1 Transmit/Receive Data	IO	A12
mcasp1_axr12	McASP1 Transmit/Receive Data	IO	E14
mcasp1_axr13	McASP1 Transmit/Receive Data	IO	A13
mcasp1_axr14	McASP1 Transmit/Receive Data	IO	G14
mcasp1_axr15	McASP1 Transmit/Receive Data	IO	F14
mcasp1_fsx	McASP1 Transmit Frame Sync	IO	D14
mcasp1_aclkr ⁽¹⁾	McASP1 Receive Bit Clock	IO	B14
mcasp1_fsr	McASP1 Receive Frame Sync	IO	J14
mcasp1_ahclkx	McASP1 Transmit High-Frequency Master Clock	O	D18
mcasp1_aclkx ⁽¹⁾	McASP1 Transmit Bit Clock	IO	C14
Multichannel Audio Serial Port 2			
mcasp2_axr0	McASP2 Transmit/Receive Data	IO	B15
mcasp2_axr1	McASP2 Transmit/Receive Data	IO	A15
mcasp2_axr2	McASP2 Transmit/Receive Data	IO	C15
mcasp2_axr3	McASP2 Transmit/Receive Data	IO	A16
mcasp2_axr4	McASP2 Transmit/Receive Data	IO	D15
mcasp2_axr5	McASP2 Transmit/Receive Data	IO	B16
mcasp2_axr6	McASP2 Transmit/Receive Data	IO	B17
mcasp2_axr7	McASP2 Transmit/Receive Data	IO	A17
mcasp2_axr8	McASP2 Transmit/Receive Data	IO	D18
mcasp2_axr9	McASP2 Transmit/Receive Data	IO	E17
mcasp2_axr10	McASP2 Transmit/Receive Data	IO	B26
mcasp2_axr11	McASP2 Transmit/Receive Data	IO	C23
mcasp2_axr12	McASP2 Transmit/Receive Data	IO	B18
mcasp2_axr13	McASP2 Transmit/Receive Data	IO	F15
mcasp2_axr14	McASP2 Transmit/Receive Data	IO	B19
mcasp2_axr15	McASP2 Transmit/Receive Data	IO	C17
mcasp2_fsx	McASP2 Transmit Frame Sync	IO	A18
mcasp2_aclkr ⁽¹⁾	McASP2 Receive Bit Clock	IO	E15
mcasp2_fsr	McASP2 Receive Frame Sync	IO	A20
mcasp2_ahclkx	McASP2 Transmit High-Frequency Master Clock	O	E17
mcasp2_aclkx ⁽¹⁾	McASP2 Transmit Bit Clock	IO	A19
Multichannel Audio Serial Port 3			
mcasp3_axr0	McASP3 Transmit/Receive Data	IO	B19
mcasp3_axr1	McASP3 Transmit/Receive Data	IO	C17
mcasp3_axr2	McASP3 Transmit/Receive Data	IO	C15
mcasp3_axr3	McASP3 Transmit/Receive Data	IO	A16
mcasp3_fsx	McASP3 Transmit Frame Sync	IO	F15
mcasp3_ahclkx	McASP3 Transmit High-Frequency Master Clock	O	B26
mcasp3_aclkx ⁽¹⁾	McASP3 Transmit Bit Clock	IO	B18
mcasp3_aclkr ⁽¹⁾	McASP3 Receive Bit Clock	IO	B18
mcasp3_fsr	McASP3 Receive Frame Sync	IO	F15
Multichannel Audio Serial Port 4			
mcasp4_axr0	McASP4 Transmit/Receive Data	IO	G16
mcasp4_axr1	McASP4 Transmit/Receive Data	IO	D17
mcasp4_axr2	McASP4 Transmit/Receive Data	IO	E12
mcasp4_axr3	McASP4 Transmit/Receive Data	IO	F13

表 4-15. McASP Signal Descriptions (continued)

SIGNAL NAME	DESCRIPTION	TYPE	BALL
mcasp4_fsx	McASP4 Transmit Frame Sync	IO	A21
mcasp4_ahclkx	McASP4 Transmit High-Frequency Master Clock	O	C23
mcasp4_aclkx ⁽¹⁾	McASP4 Transmit Bit Clock	IO	C18
mcasp4_aclkr ⁽¹⁾	McASP4 Receive Bit Clock	IO	C18
mcasp4_fsr	McASP4 Receive Frame Sync	IO	A21
Multichannel Audio Serial Port 5			
mcasp5_axr0	McASP5 Transmit/Receive Data	IO	AB3
mcasp5_axr1	McASP5 Transmit/Receive Data	IO	AA4
mcasp5_axr2	McASP5 Transmit/Receive Data	IO	C12
mcasp5_axr3	McASP5 Transmit/Receive Data	IO	D12
mcasp5_fsx	McASP5 Transmit Frame Sync	IO	AB9
mcasp5_ahclkx	McASP5 Transmit High-Frequency Master Clock	O	D18
mcasp5_aclkx ⁽¹⁾	McASP5 Transmit Bit Clock	IO	AA3
mcasp5_aclkr ⁽¹⁾	McASP5 Receive Bit Clock	IO	AA3
mcasp5_fsr	McASP5 Receive Frame Sync	IO	AB9
Multichannel Audio Serial Port 6			
mcasp6_axr0	McASP6 Transmit/Receive Data	IO	B12
mcasp6_axr1	McASP6 Transmit/Receive Data	IO	A11
mcasp6_axr2	McASP6 Transmit/Receive Data	IO	G13
mcasp6_axr3	McASP6 Transmit/Receive Data	IO	J11
mcasp6_ahclkx	McASP6 Transmit High-Frequency Master Clock	O	E17
mcasp6_aclkx ⁽¹⁾	McASP6 Transmit Bit Clock	IO	B13
mcasp6_fsx	McASP6 Transmit Frame Sync	IO	A12
mcasp6_aclkr ⁽¹⁾	McASP6 Receive Bit Clock	IO	B13
mcasp6_fsr	McASP6 Receive Frame Sync	IO	A12
Multichannel Audio Serial Port 7			
mcasp7_axr0	McASP7 Transmit/Receive Data	IO	E14
mcasp7_axr1	McASP7 Transmit/Receive Data	IO	A13
mcasp7_axr2	McASP7 Transmit/Receive Data	IO	B14
mcasp7_axr3	McASP7 Transmit/Receive Data	IO	J14
mcasp7_ahclkx	McASP7 Transmit High-Frequency Master Clock	O	B26
mcasp7_aclkx ⁽¹⁾	McASP7 Transmit Bit Clock	IO	G14
mcasp7_fsx	McASP7 Transmit Frame Sync	IO	F14
mcasp7_aclkr ⁽¹⁾	McASP7 Receive Bit Clock	IO	G14
mcasp7_fsr	McASP7 Receive Frame Sync	IO	F14
Multichannel Audio Serial Port 8			
mcasp8_axr0	McASP8 Transmit/Receive Data	IO	D15
mcasp8_axr1	McASP8 Transmit/Receive Data	IO	B16
mcasp8_axr2	McASP8 Transmit/Receive Data	IO	E15
mcasp8_axr3	McASP8 Transmit/Receive Data	IO	A20
mcasp8_ahclkx	McASP8 Transmit High-Frequency Master Clock	O	C23
mcasp8_aclkx ⁽¹⁾	McASP8 Transmit Bit Clock	IO	B17
mcasp8_fsx	McASP8 Transmit Frame Sync	IO	A17
mcasp8_aclkr ⁽¹⁾	McASP8 Receive Bit Clock	IO	B17
mcasp8_fsr	McASP8 Receive Frame Sync	IO	A17

- (1) This clock signal is implemented as 'pad loopback' inside the device - the output signal is looped back through the input buffer to serve as the internal reference signal. Series termination is recommended (as close to device pin as possible) to improve signal integrity of the clock input. Any non-monotonicity in voltage that occurs at the pad loopback clock pin between V_{IH} and V_{IL} must be less than V_{HYS} .

4.4.13 Universal Serial Bus (USB)

注: For more information, see: Serial Communication Interface / SuperSpeed USB DRD Subsystem section of the device TRM.

表 4-16. Universal Serial Bus Signal Descriptions

SIGNAL NAME	DESCRIPTION	TYPE	BALL
Universal Serial Bus 1			
usb1_dp	USB1 USB2.0 differential signal pair (positive)	IO	AD12
usb1_dm	USB1 USB2.0 differential signal pair (negative)	IO	AC12
usb1_drvvbus	USB1 Drive VBUS signal	O	AB10
usb_rxn0	USB1 USB3.0 receiver negative lane	I	AF12
usb_rxp0	USB1 USB3.0 receiver positive lane	I	AE12
usb_txn0	USB1 USB3.0 transmitter negative lane	O	AC11
usb_txp0	USB1 USB3.0 transmitter positive lane	O	AD11
Universal Serial Bus 2			
usb2_dp	USB2 USB2.0 differential signal pair (positive)	IO	AE11
usb2_dm	USB2 USB2.0 differential signal pair (negative)	IO	AF11
usb2_drvvbus	USB2 Drive VBUS signal	O	AC10
Universal Serial Bus 3			
usb3_ulpi_d0	USB3 - ULPI 8-bit data bus	IO	AC3 / AE1
usb3_ulpi_d1	USB3 - ULPI 8-bit data bus	IO	AC9 / AE5
usb3_ulpi_d2	USB3 - ULPI 8-bit data bus	IO	AC6 / AE3
usb3_ulpi_d3	USB3 - ULPI 8-bit data bus	IO	AC7 / AF1
usb3_ulpi_d4	USB3 - ULPI 8-bit data bus	IO	AC4 / AF4
usb3_ulpi_d5	USB3 - ULPI 8-bit data bus	IO	AD4 / AF3
usb3_ulpi_d6	USB3 - ULPI 8-bit data bus	IO	AB4 / AF6
usb3_ulpi_d7	USB3 - ULPI 8-bit data bus	IO	AC5 / AF2
usb3_ulpi_nxt	USB3 - ULPI next	I	AC8 / AE2
usb3_ulpi_dir	USB3 - ULPI bus direction	I	AD6 / AE6
usb3_ulpi_stp	USB3 - ULPI stop	O	AB8 / AD2
usb3_ulpi_clk	USB3 - ULPI functional clock	I	AB5 / AD3
Universal Serial Bus 4			
usb4_ulpi_d0	USB4 - ULPI 8-bit data bus ⁽¹⁾	IO	V6
usb4_ulpi_d1	USB4 - ULPI 8-bit data bus ⁽¹⁾	IO	U6
usb4_ulpi_d2	USB4 - ULPI 8-bit data bus ⁽¹⁾	IO	U5
usb4_ulpi_d3	USB4 - ULPI 8-bit data bus ⁽¹⁾	IO	V5
usb4_ulpi_d4	USB4 - ULPI 8-bit data bus ⁽¹⁾	IO	V4
usb4_ulpi_d5	USB4 - ULPI 8-bit data bus ⁽¹⁾	IO	V3
usb4_ulpi_d6	USB4 - ULPI 8-bit data bus ⁽¹⁾	IO	Y2
usb4_ulpi_d7	USB4 - ULPI 8-bit data bus ⁽¹⁾	IO	W2
usb4_ulpi_nxt	USB4 - ULPI next ⁽¹⁾	I	U7
usb4_ulpi_dir	USB4 - ULPI bus direction ⁽¹⁾	I	V7
usb4_ulpi_stp	USB4 - ULPI stop ⁽¹⁾	O	V9
usb4_ulpi_clk	USB4 - ULPI functional clock ⁽¹⁾	I	W9

(1) USB4 will not be supported on some pin-compatible roadmap devices. USB3 will be mapped to these balls instead. Pin compatibility can be maintained in the future by either not using USB4, or via software change to use USB4 on this device, but USB3 on these balls in the future.

4.4.14 SATA

注: For more information, see the Serial Communication Interfaces / SATA section of the device TRM.

表 4-17. SATA Signal Descriptions

SIGNAL NAME	DESCRIPTION	TYPE	BALL
sata1_rxn0	SATA differential negative receiver lane 0	IOS	AH9
sata1_rxp0	SATA differential positive receiver lane 0	IOS	AG9
sata1_txn0	SATA differential negative transmitter lane 0	ODS	AG10
sata1_txp0	SATA differential positive transmitter lane 0	ODS	AH10
sata1_led	SATA channel activity indicator	O	A22 / G19

4.4.15 Peripheral Component Interconnect Express (PCIe)

注: For more information, see the *Serial Communication Interfaces / PCIe Controllers* and the *Shared PHY Component Subsystems / PCIe Shared PHY Subsystem* sections of the device TRM.

注: In the DRA74x device, the PCIe_SS2 controller is NOT available, and the PCIe_SS1 controller supports only a single lane. The PCIe2_PHY interface signal set (pcie_rxn1/rxp1, pcie_txn1/txp1 in 表 4-18) is **NOT supported in the DRA74x device**. For more details on the device differentiation, refer to the 表 3-1, *Device Comparison*.

表 4-18. PCIe Signal Descriptions

SIGNAL NAME	DESCRIPTION	TYPE	BALL
pcie_rxn0	PCIe1_PHY_RX Receive Data Lane 0 (negative) - mapped to PCIe_SS1 only.	IOS	AG13
pcie_rxp0	PCIe1_PHY_RX Receive Data Lane 0 (positive) - mapped to PCIe_SS1 only.	IOS	AH13
pcie_txn0	PCIe1_PHY_TX Transmit Data Lane 0 (negative) - mapped to PCIe_SS1 only.	ODS	AG14
pcie_txp0	PCIe1_PHY_TX Transmit Data Lane 0 (positive) - mapped to PCIe_SS1 only.	ODS	AH14
pcie_rxn1 ⁽¹⁾	PCIe2_PHY_RX Receive Data Lane 1 (negative) - mapped to either PCIe_SS1 (dual lane- mode) or PCIe_SS2 (single lane- mode)	IOS	AG11
pcie_rxp1 ⁽¹⁾	PCIe2_PHY_RX Receive Data Lane 1 (positive) - mapped to either PCIe_SS1 (dual lane- mode) or PCIe_SS2 (single lane- mode)	IOS	AH11
pcie_txn1 ⁽¹⁾	PCIe2_PHY_TX Transmit Data Lane 1 (negative) - mapped to either PCIe_SS1 (dual lane- mode) or PCIe_SS2 (single lane- mode)	ODS	AG12
pcie_txp1 ⁽¹⁾	PCIe2_PHY_TX Transmit Data Lane 1 (positive) - mapped to either PCIe_SS1 (dual lane- mode) or PCIe_SS2 (single lane- mode)	ODS	AH12
ljcb_clkp	PCIe1_PHY / PCIe2_PHY shared Reference Clock Input / Output Differential Pair (positive)	IODS	AG15
ljcb_clkn	PCIe1_PHY / PCIe2_PHY shared Reference Clock Input / Output Differential Pair (negative)	IODS	AH15

(1) This is not applicable for DRA74x devices.

4.4.16 Controller Area Network Interface (DCAN)

注: For more information, see the Serial Communication Interface / DCAN section of the device TRM.

表 4-19. DCAN Signal Descriptions

SIGNAL NAME	DESCRIPTION	TYPE	BALL
DCAN 1			
dcan1_tx	DCAN1 transmit data pin	IO	G20
dcan1_rx	DCAN1 receive data pin	IO	G19 / AD17
DCAN 2			
dcan2_tx	DCAN2 transmit data pin	IO	E21/ B21
dcan2_rx	DCAN2 receive data pin	IO	F20/ AC17/ B20

4.4.17 Ethernet Interface (GMAC_SW)

注意

The I/O timings provided in [7, Timing Requirements and Switching Characteristics](#) are valid only if signals within a single IOSET are used. The IOSETs are defined in the [表 7-75, 表 7-78, 表 7-83 and 表 7-90](#).

注: For more information, see the Serial Communication Interfaces / Ethernet Controller section of the device TRM.

表 4-20. GMAC Signal Descriptions

SIGNAL NAME	DESCRIPTION	TYPE	BALL
rgmii0_txc	RGMIIO Transmit Clock	O	W9
rgmii0_txctl	RGMIIO Transmit Enable	O	V9
rgmii0_txd3	RGMIIO Transmit Data	O	V7
rgmii0_txd2	RGMIIO Transmit Data	O	U7
rgmii0_txd1	RGMIIO Transmit Data	O	V6
rgmii0_txd0	RGMIIO Transmit Data	O	U6
rgmii0_rxc	RGMIIO Receive Clock	I	U5
rgmii0_rxctl	RGMIIO Receive Control	I	V5
rgmii0_rxd3	RGMIIO Receive Data	I	V4
rgmii0_rxd2	RGMIIO Receive Data	I	V3
rgmii0_rxd1	RGMIIO Receive Data	I	Y2
rgmii0_rxd0	RGMIIO Receive Data	I	W2
rgmii1_txc	RGMI1 Transmit Clock	O	D5
rgmii1_txctl	RGMI1 Transmit Enable	O	C2
rgmii1_txd3	RGMI1 Transmit Data	O	C3
rgmii1_txd2	RGMI1 Transmit Data	O	C4
rgmii1_txd1	RGMI1 Transmit Data	O	B2
rgmii1_txd0	RGMI1 Transmit Data	O	D6

表 4-20. GMAC Signal Descriptions (continued)

SIGNAL NAME	DESCRIPTION	TYPE	BALL
rgmii1_rxc	RGMII1 Receive Clock	I	C5
rgmii1_rxctl	RGMII1 Receive Control	I	A3
rgmii1_rxd3	RGMII1 Receive Data	I	B3
rgmii1_rxd2	RGMII1 Receive Data	I	B4
rgmii1_rxd1	RGMII1 Receive Data	I	B5
rgmii1_rxd0	RGMII1 Receive Data	I	A4
mii1_rxd1	MII1 Receive Data	I	C1
mii1_rxd2	MII1 Receive Data	I	E4
mii1_rxd3	MII1 Receive Data	I	F5
mii1_rxd0	MII1 Receive Data	I	E6
mii1_rxclk	MII1 Receive Clock	I	D5
mii1_rxdv	MII1 Receive Data Valid	I	C2
mii1_txclk	MII1 Transmit Clock	I	C3
mii1_txd0	MII1 Transmit Data	O	C4
mii1_txd1	MII1 Transmit Data	O	B2
mii1_txd2	MII1 Transmit Data	O	D6
mii1_txd3	MII1 Transmit Data	O	C5
mii1_txer	MII1 Transmit Error	O	A3
mii1_rxer	MII1 Receive Data Error	I	B3
mii1_col	MII1 Collision Detect (Sense)	I	B4
mii1_crs	MII1 Carrier Sense	I	B5
mii1_txen	MII1 Transmit Data Enable	O	A4
mii0_rxd1	MII0 Receive Data	I	V6
mii0_rxd2	MII0 Receive Data	I	V9
mii0_rxd3	MII0 Receive Data	I	W9
mii0_rxd0	MII0 Receive Data	I	U6
mii0_rxclk	MII0 Receive Clock	I	Y1
mii0_rxdv	MII0 Receive Data Valid	I	V2
mii0_txclk	MII0 Transmit Clock	I	U5
mii0_txd0	MII0 Transmit Data	O	W2
mii0_txd1	MII0 Transmit Data	O	Y2
mii0_txd2	MII0 Transmit Data	O	V4
mii0_txd3	MII0 Transmit Data	O	V5
mii0_txer	MII0 Transmit Error	O	U4
mii0_rxer	MII0 Receive Data Error	I	U7
mii0_col	MII0 Collision Detect (Sense)	I	V1
mii0_crs	MII0 Carrier Sense	I	V7
mii0_txen	MII0 Transmit Data Enable	O	V3
rmii1_crs	RMII1 Carrier Sense	I	V2
rmii1_rxer	RMII1 Receive Data Error	I	Y1
rmii1_rxd1	RMII1 Receive Data	I	W9
rmii1_rxd0	RMII1 Receive Data	I	V9
rmii1_txen	RMII1 Transmit Data Enable	O	U5
rmii1_txd1	RMII1 Transmit Data	O	V5
rmii1_txd0	RMII1 Transmit Data	O	V4
rmii0_crs	RMII0 Carrier Sense	I	V7
rmii0_rxer	RMII0 Receive Data Error	I	U7

表 4-20. GMAC Signal Descriptions (continued)

SIGNAL NAME	DESCRIPTION	TYPE	BALL
rmiio_rxd1	RMII0 Receive Data	I	V6
rmiio_rxd0	RMII0 Receive Data	I	U6
rmiio_txen	RMII0 Transmit Data Enable	O	V3
rmiio_txd1	RMII0 Transmit Data	O	Y2
rmiio_txd0	RMII0 Transmit Data	O	W2
mdio_mclk	Management Data Serial Clock	O	AC5 / V1 / B21 / D3
mdio_d	Management Data	IO	AB4 / U4 / B20 / F6

4.4.18 Media Local Bus (MLB) Interface

注: MLB in 6-pin mode may require pullups/ pulldowns on SIG and DAT bus signals.

For additional details, please consult the MLB bus interface specification.

注: For more information, see the Serial Communication Interface / Media Local Bus (MLB) section of the device TRM.

表 4-21. MLB Signal Descriptions

SIGNAL NAME	DESCRIPTION	TYPE	BALL
mlb_sig	Media Local Bus (MLB) Subsystem signal	IO	AB3
mlb_dat	Media Local Bus (MLB) Subsystem data	IO	AA4
mlb_clk	Media Local Bus (MLB) Subsystem clock	I	AA3
mlbp_sig_p	Media Local Bus (MLB) Subsystem signal differential pair (positive)	IODS	AC1
mlbp_sig_n	Media Local Bus (MLB) Subsystem signal differential pair (negative)	IODS	AC2
mlbp_dat_p	Media Local Bus (MLB) Subsystem data differential pair (positive)	IODS	AA1
mlbp_dat_n	Media Local Bus (MLB) Subsystem data differential pair (negative)	IODS	AA2
mlbp_clk_p	Media Local Bus (MLB) Subsystem clock differential pair (positive)	IOS	AB1
mlbp_clk_n	Media Local Bus (MLB) Subsystem clock differential pair (negative)	IOS	AB2

4.4.19 eMMC/SD/SDIO

注: For more information, see the HS MMC/SDIO section of the device TRM.

表 4-22. eMMC/SD/SDIO Signal Descriptions

SIGNAL NAME	DESCRIPTION	TYPE	BALL
Multi Media Card 1			
mmc1_clk ⁽¹⁾	MMC1 clock	IO	W6
mmc1_cmd	MMC1 command	IO	Y6
mmc1_sdcd	MMC1 Card Detect	I	W7
mmc1_sdpw	MMC1 Write Protect	I	Y9
mmc1_dat0	MMC1 data bit 0	IO	AA6
mmc1_dat1	MMC1 data bit 1	IO	Y4
mmc1_dat2	MMC1 data bit 2	IO	AA5
mmc1_dat3	MMC1 data bit 3	IO	Y3
Multi Media Card 2			

表 4-22. eMMC/SD/SDIO Signal Descriptions (continued)

SIGNAL NAME	DESCRIPTION	TYPE	BALL
mmc2_clk ⁽¹⁾	MMC2 clock	IO	J7
mmc2_cmd	MMC2 command	IO	H6
mmc2_sdcd	MMC2 Card Detect	I	G20
mmc2_sdwp	MMC2 Write Protect	I	G19
mmc2_dat0	MMC2 data bit 0	IO	J4
mmc2_dat1	MMC2 data bit 1	IO	J6
mmc2_dat2	MMC2 data bit 2	IO	H4
mmc2_dat3	MMC2 data bit 3	IO	H5
mmc2_dat4	MMC2 data bit 4	IO	K7
mmc2_dat5	MMC2 data bit 5	IO	M7
mmc2_dat6	MMC2 data bit 6	IO	J5
mmc2_dat7	MMC2 data bit 7	IO	K6
Multi Media Card 3			
mmc3_clk ⁽¹⁾	MMC3 clock	IO	AD4
mmc3_cmd	MMC3 command	IO	AC4
mmc3_sdcd	MMC3 Card Detect	I	B21
mmc3_sdwp	MMC3 Write Protect	I	B20
mmc3_dat0	MMC3 data bit 0	IO	AC7
mmc3_dat1	MMC3 data bit 1	IO	AC6
mmc3_dat2	MMC3 data bit 2	IO	AC9
mmc3_dat3	MMC3 data bit 3	IO	AC3
mmc3_dat4	MMC3 data bit 4	IO	AC8
mmc3_dat5	MMC3 data bit 5	IO	AD6
mmc3_dat6	MMC3 data bit 6	IO	AB8
mmc3_dat7	MMC3 data bit 7	IO	AB5
Multi Media Card 4			
mmc4_sdcd	MMC4 Card Detect	I	B27
mmc4_sdwp	MMC4 Write Protect	I	C26
mmc4_clk ⁽¹⁾	MMC4 clock	IO	E25
mmc4_cmd	MMC4 command	IO	C27
mmc4_dat0	MMC4 data bit 0	IO	D28
mmc4_dat1	MMC4 data bit 1	IO	D26
mmc4_dat2	MMC4 data bit 2	IO	D27
mmc4_dat3	MMC4 data bit 3	IO	C28

(1) By default, this clock signal is implemented as 'pad loopback' inside the device - the output signal is looped back through the input buffer to serve as the internal reference signal. mmc1_clk and mmc2_clk have an optional software programmable setting to use an 'internal loopback clock' instead of the default 'pad loopback clock'. If the 'pad loopback clock' is used, series termination is recommended (as close to device pin as possible) to improve signal integrity of the clock input. Any non-monotonicity in voltage that occurs at the pad loopback clock pin between V_{IH} and V_{IL} must be less than V_{HYS} .

4.4.20 General-Purpose Interface (GPIO)

注: For more information, see the General-Purpose Interface section of the device TRM.

表 4-23. GPIOs Signal Descriptions

SIGNAL NAME	DESCRIPTION	TYPE	BALL
GPIO 1			

表 4-23. GPIOs Signal Descriptions (continued)

SIGNAL NAME	DESCRIPTION	TYPE	BALL
gpio1_0	General-Purpose Input	I	AD17
gpio1_1	General-Purpose Input	I	AC17
gpio1_2	General-Purpose Input	I	AB16
gpio1_3	General-Purpose Input	I	AC16
gpio1_4	General-Purpose Input/Output	IO	D15
gpio1_5	General-Purpose Input/Output	IO	A17
gpio1_6	General-Purpose Input/Output	IO	M6
gpio1_7	General-Purpose Input/Output	IO	M2
gpio1_8	General-Purpose Input/Output	IO	L5
gpio1_9	General-Purpose Input/Output	IO	M1
gpio1_10	General-Purpose Input/Output	IO	L6
gpio1_11	General-Purpose Input/Output	IO	L4
gpio1_12	General-Purpose Input/Output	IO	L3
gpio1_13	General-Purpose Input/Output	IO	L2
gpio1_14	General-Purpose Input/Output	IO	G20
gpio1_15	General-Purpose Input/Output	IO	G19
gpio1_16	General-Purpose Input/Output	IO	D27
gpio1_17	General-Purpose Input/Output	IO	C28
gpio1_18	General-Purpose Input/Output	IO	H1
gpio1_19	General-Purpose Input/Output	IO	J3
gpio1_20	General-Purpose Input/Output	IO	H2
gpio1_21	General-Purpose Input/Output	IO	H3
gpio1_22	General-Purpose Input/Output	IO	AC8
gpio1_23	General-Purpose Input/Output	IO	AD6
gpio1_24	General-Purpose Input/Output	IO	AB8
gpio1_25	General-Purpose Input/Output	IO	AB5
gpio1_26	General-Purpose Input/Output	IO	P6
gpio1_27	General-Purpose Input/Output	IO	R9
gpio1_28	General-Purpose Input/Output	IO	R5
gpio1_29	General-Purpose Input/Output	IO	P5
gpio1_30	General-Purpose Input/Output	IO	N7
gpio1_31	General-Purpose Input/Output	IO	R4
GPIO 2			
gpio2_0	General-Purpose Input/Output	IO	N9
gpio2_1	General-Purpose Input/Output	IO	P9
gpio2_2	General-Purpose Input/Output	IO	P4
gpio2_3	General-Purpose Input/Output	IO	R3
gpio2_4	General-Purpose Input/Output	IO	T2
gpio2_5	General-Purpose Input/Output	IO	U2
gpio2_6	General-Purpose Input/Output	IO	U1
gpio2_7	General-Purpose Input/Output	IO	P3
gpio2_8	General-Purpose Input/Output	IO	R2
gpio2_9	General-Purpose Input/Output	IO	K7
gpio2_10	General-Purpose Input/Output	IO	M7
gpio2_11	General-Purpose Input/Output	IO	J5
gpio2_12	General-Purpose Input/Output	IO	K6
gpio2_13	General-Purpose Input/Output	IO	J7

表 4-23. GPIOs Signal Descriptions (continued)

SIGNAL NAME	DESCRIPTION	TYPE	BALL
gpio2_14	General-Purpose Input/Output	IO	J4
gpio2_15	General-Purpose Input/Output	IO	J6
gpio2_16	General-Purpose Input/Output	IO	H4
gpio2_17	General-Purpose Input/Output	IO	H5
gpio2_18	General-Purpose Input/Output	IO	H6
gpio2_19	General-Purpose Input/Output	IO	T1
gpio2_20	General-Purpose Input/Output	IO	P2
gpio2_21	General-Purpose Input/Output	IO	P1
gpio2_22	General-Purpose Input/Output	IO	P7
gpio2_23	General-Purpose Input/Output	IO	N1
gpio2_24	General-Purpose Input/Output	IO	M5
gpio2_25	General-Purpose Input/Output	IO	M3
gpio2_26	General-Purpose Input/Output	IO	N6
gpio2_27	General-Purpose Input/Output	IO	M4
gpio2_28	General-Purpose Input/Output	IO	N2
gpio2_29	General-Purpose Input/Output	IO	B17
gpio2_30	General-Purpose Input/Output	IO	AG8
gpio2_31	General-Purpose Input/Output	IO	AH7
GPIO 3			
gpio3_0	General-Purpose Input/Output	IO	AD9
gpio3_1	General-Purpose Input/Output	IO	AF9
gpio3_2	General-Purpose Input/Output	IO	AE9
gpio3_3	General-Purpose Input/Output	IO	AF8
gpio3_4	General-Purpose Input/Output	IO	AE8
gpio3_5	General-Purpose Input/Output	IO	AD8
gpio3_6	General-Purpose Input/Output	IO	AG7
gpio3_7	General-Purpose Input/Output	IO	AH6
gpio3_8	General-Purpose Input/Output	IO	AH3
gpio3_9	General-Purpose Input/Output	IO	AH5
gpio3_10	General-Purpose Input/Output	IO	AG6
gpio3_11	General-Purpose Input/Output	IO	AH4
gpio3_12	General-Purpose Input/Output	IO	AG4
gpio3_13	General-Purpose Input/Output	IO	AG2
gpio3_14	General-Purpose Input/Output	IO	AG3
gpio3_15	General-Purpose Input/Output	IO	AG5
gpio3_16	General-Purpose Input/Output	IO	AF2
gpio3_17	General-Purpose Input/Output	IO	AF6
gpio3_18	General-Purpose Input/Output	IO	AF3
gpio3_19	General-Purpose Input/Output	IO	AF4
gpio3_20	General-Purpose Input/Output	IO	AF1
gpio3_21	General-Purpose Input/Output	IO	AE3
gpio3_22	General-Purpose Input/Output	IO	AE5
gpio3_23	General-Purpose Input/Output	IO	AE1
gpio3_24	General-Purpose Input/Output	IO	AE2
gpio3_25	General-Purpose Input/Output	IO	AE6
gpio3_26	General-Purpose Input/Output	IO	AD2
gpio3_27	General-Purpose Input/Output	IO	AD3

表 4-23. GPIOs Signal Descriptions (continued)

SIGNAL NAME	DESCRIPTION	TYPE	BALL
gpio3_28	General-Purpose Input/Output	IO	E1
gpio3_29	General-Purpose Input/Output	IO	G2
gpio3_30	General-Purpose Input/Output	IO	H7
gpio3_31	General-Purpose Input/Output	IO	G1
GPIO 4			
gpio4_0	General-Purpose Input/Output	IO	G6
gpio4_1	General-Purpose Input/Output	IO	F2
gpio4_2	General-Purpose Input/Output	IO	F3
gpio4_3	General-Purpose Input/Output	IO	D1
gpio4_4	General-Purpose Input/Output	IO	E2
gpio4_5	General-Purpose Input/Output	IO	D2
gpio4_6	General-Purpose Input/Output	IO	F4
gpio4_7	General-Purpose Input/Output	IO	C1
gpio4_8	General-Purpose Input/Output	IO	E4
gpio4_9	General-Purpose Input/Output	IO	F5
gpio4_10	General-Purpose Input/Output	IO	E6
gpio4_11	General-Purpose Input/Output	IO	D3
gpio4_12	General-Purpose Input/Output	IO	F6
gpio4_13	General-Purpose Input/Output	IO	D5
gpio4_14	General-Purpose Input/Output	IO	C2
gpio4_15	General-Purpose Input/Output	IO	C3
gpio4_16	General-Purpose Input/Output	IO	C4
gpio4_17	General-Purpose Input/Output	IO	A12
gpio4_18	General-Purpose Input/Output	IO	E14
gpio4_19	General-Purpose Input/Output	IO	D11
gpio4_20	General-Purpose Input/Output	IO	B10
gpio4_21	General-Purpose Input/Output	IO	B11
gpio4_22	General-Purpose Input/Output	IO	C11
gpio4_23	General-Purpose Input/Output	IO	E11
gpio4_24	General-Purpose Input/Output	IO	B2
gpio4_25	General-Purpose Input/Output	IO	D6
gpio4_26	General-Purpose Input/Output	IO	C5
gpio4_27	General-Purpose Input/Output	IO	A3
gpio4_28	General-Purpose Input/Output	IO	B3
gpio4_29	General-Purpose Input/Output	IO	B4
gpio4_30	General-Purpose Input/Output	IO	B5
gpio4_31	General-Purpose Input/Output	IO	A4
GPIO 5			
gpio5_0	General-Purpose Input/Output	IO	B14
gpio5_1	General-Purpose Input/Output	IO	J14
gpio5_2	General-Purpose Input/Output	IO	G12
gpio5_3	General-Purpose Input/Output	IO	F12
gpio5_4	General-Purpose Input/Output	IO	G13
gpio5_5	General-Purpose Input/Output	IO	J11
gpio5_6	General-Purpose Input/Output	IO	E12
gpio5_7	General-Purpose Input/Output	IO	F13
gpio5_8	General-Purpose Input/Output	IO	C12

表 4-23. GPIOs Signal Descriptions (continued)

SIGNAL NAME	DESCRIPTION	TYPE	BALL
gpio5_9	General-Purpose Input/Output	IO	D12
gpio5_10	General-Purpose Input/Output	IO	B12
gpio5_11	General-Purpose Input/Output	IO	A11
gpio5_12	General-Purpose Input/Output	IO	B13
gpio5_13	General-Purpose Input/Output	IO	B18
gpio5_14	General-Purpose Input/Output	IO	F15
gpio5_15	General-Purpose Input/Output	IO	V1
gpio5_16	General-Purpose Input/Output	IO	U4
gpio5_17	General-Purpose Input/Output	IO	U3
gpio5_18	General-Purpose Input/Output	IO	V2
gpio5_19	General-Purpose Input/Output	IO	Y1
gpio5_20	General-Purpose Input/Output	IO	W9
gpio5_21	General-Purpose Input/Output	IO	V9
gpio5_22	General-Purpose Input/Output	IO	V7
gpio5_23	General-Purpose Input/Output	IO	U7
gpio5_24	General-Purpose Input/Output	IO	V6
gpio5_25	General-Purpose Input/Output	IO	U6
gpio5_26	General-Purpose Input/Output	IO	U5
gpio5_27	General-Purpose Input/Output	IO	V5
gpio5_28	General-Purpose Input/Output	IO	V4
gpio5_29	General-Purpose Input/Output	IO	V3
gpio5_30	General-Purpose Input/Output	IO	Y2
gpio5_31	General-Purpose Input/Output	IO	W2
GPIO 6			
gpio6_4	General-Purpose Input/Output	IO	A13
gpio6_5	General-Purpose Input/Output	IO	G14
gpio6_6	General-Purpose Input/Output	IO	F14
gpio6_7	General-Purpose Input/Output	IO	B16
gpio6_8	General-Purpose Input/Output	IO	C15
gpio6_9	General-Purpose Input/Output	IO	A16
gpio6_10	General-Purpose Input/Output	IO	AC5
gpio6_11	General-Purpose Input/Output	IO	AB4
gpio6_12	General-Purpose Input/Output	IO	AB10
gpio6_13	General-Purpose Input/Output	IO	AC10
gpio6_14	General-Purpose Input/Output	IO	E21
gpio6_15	General-Purpose Input/Output	IO	F20
gpio6_16	General-Purpose Input/Output	IO	F21
gpio6_17	General-Purpose Input/Output	IO	D18
gpio6_18	General-Purpose Input/Output	IO	E17
gpio6_19	General-Purpose Input/Output	IO	B26
gpio6_20	General-Purpose Input/Output	IO	C23
gpio6_21	General-Purpose Input/Output	IO	W6
gpio6_22	General-Purpose Input/Output	IO	Y6
gpio6_23	General-Purpose Input/Output	IO	AA6
gpio6_24	General-Purpose Input/Output	IO	Y4
gpio6_25	General-Purpose Input/Output	IO	AA5
gpio6_26	General-Purpose Input/Output	IO	Y3

表 4-23. GPIOs Signal Descriptions (continued)

SIGNAL NAME	DESCRIPTION	TYPE	BALL
gpio6_27	General-Purpose Input/Output	IO	W7
gpio6_28	General-Purpose Input/Output	IO	Y9
gpio6_29	General-Purpose Input/Output	IO	AD4
gpio6_30	General-Purpose Input/Output	IO	AC4
gpio6_31	General-Purpose Input/Output	IO	AC7
GPIO 7			
gpio7_0	General-Purpose Input/Output	IO	AC6
gpio7_1	General-Purpose Input/Output	IO	AC9
gpio7_2	General-Purpose Input/Output	IO	AC3
gpio7_3	General-Purpose Input/Output	IO	R6
gpio7_4	General-Purpose Input/Output	IO	T9
gpio7_5	General-Purpose Input/Output	IO	T6
gpio7_6	General-Purpose Input/Output	IO	T7
gpio7_7	General-Purpose Input/Output	IO	A25
gpio7_8	General-Purpose Input/Output	IO	F16
gpio7_9	General-Purpose Input/Output	IO	B25
gpio7_10	General-Purpose Input/Output	IO	A24
gpio7_11	General-Purpose Input/Output	IO	A22
gpio7_12	General-Purpose Input/Output	IO	B21
gpio7_13	General-Purpose Input/Output	IO	B20
gpio7_14	General-Purpose Input/Output	IO	A26
gpio7_15	General-Purpose Input/Output	IO	B22
gpio7_16	General-Purpose Input/Output	IO	G17
gpio7_17	General-Purpose Input/Output	IO	B24
gpio7_18	General-Purpose Input/Output	IO	L1
gpio7_19	General-Purpose Input/Output	IO	K2
gpio7_22	General-Purpose Input/Output	IO	B27
gpio7_23	General-Purpose Input/Output	IO	C26
gpio7_24	General-Purpose Input/Output	IO	E25
gpio7_25	General-Purpose Input/Output	IO	C27
gpio7_26	General-Purpose Input/Output	IO	D28
gpio7_27	General-Purpose Input/Output	IO	D26
gpio7_28	General-Purpose Input/Output	IO	J1
gpio7_29	General-Purpose Input/Output	IO	J2
gpio7_30	General-Purpose Input/Output	IO	D14
gpio7_31	General-Purpose Input/Output	IO	C14
GPIO 8			
gpio8_0	General-Purpose Input/Output	IO	F11
gpio8_1	General-Purpose Input/Output	IO	G10
gpio8_2	General-Purpose Input/Output	IO	F10
gpio8_3	General-Purpose Input/Output	IO	G11
gpio8_4	General-Purpose Input/Output	IO	E9
gpio8_5	General-Purpose Input/Output	IO	F9
gpio8_6	General-Purpose Input/Output	IO	F8
gpio8_7	General-Purpose Input/Output	IO	E7
gpio8_8	General-Purpose Input/Output	IO	E8
gpio8_9	General-Purpose Input/Output	IO	D9

表 4-23. GPIOs Signal Descriptions (continued)

SIGNAL NAME	DESCRIPTION	TYPE	BALL
gpio8_10	General-Purpose Input/Output	IO	D7
gpio8_11	General-Purpose Input/Output	IO	D8
gpio8_12	General-Purpose Input/Output	IO	A5
gpio8_13	General-Purpose Input/Output	IO	C6
gpio8_14	General-Purpose Input/Output	IO	C8
gpio8_15	General-Purpose Input/Output	IO	C7
gpio8_16	General-Purpose Input/Output	IO	B7
gpio8_17	General-Purpose Input/Output	IO	B8
gpio8_18	General-Purpose Input/Output	IO	A7
gpio8_19	General-Purpose Input/Output	IO	A8
gpio8_20	General-Purpose Input/Output	IO	C9
gpio8_21	General-Purpose Input/Output	IO	A9
gpio8_22	General-Purpose Input/Output	IO	B9
gpio8_23	General-Purpose Input/Output	IO	A10
gpio8_27	General-Purpose Input	I	D23
gpio8_28	General-Purpose Input/Output	IO	F19
gpio8_29	General-Purpose Input/Output	IO	E18
gpio8_30 ⁽¹⁾	General-Purpose Input/Output	IO	G21
gpio8_31 ⁽¹⁾	General-Purpose Input/Output	IO	D24

(1) gpio8_30 is multiplexed with EMU0 and gpio8_31 is multiplexed with EMU1. These pins will be sampled at reset release by the test and emulation logic. Therefore, if they are used as GPIO pins, they must return to the high state whenever the device enters reset. This can be controlled by logic driven from rstoutn. After the device exits reset (indicated by rstoutn rising), these can return to GPIO mode.

4.4.21 Keyboard controller (KBD)

注: For more information, see Keyboard Controller section of the device TRM.

表 4-24. Keyboard Signal Descriptions

SIGNAL NAME	DESCRIPTION	TYPE	BALL
kbd_row0	Keypad row 0	I	AD9/ E1
kbd_row1	Keypad row 1	I	AF9/ G2
kbd_row2	Keypad row 2	I	AG4/ G1
kbd_row3	Keypad row 3	I	AG2/ G6
kbd_row4	Keypad row 4	I	AG3/ F2
kbd_row5	Keypad row 5	I	AG5/ F3
kbd_row6	Keypad row 6	I	AF2/ D1
kbd_row7	Keypad row 7	I	AF6/ F6
kbd_row8	Keypad row 8	I	AF3/ C2
kbd_col0	Keypad column 0	O	AF4/ E2
kbd_col1	Keypad column 1	O	AF1/ D2
kbd_col2	Keypad column 2	O	AE3/ F4
kbd_col3	Keypad column 3	O	AE5/ C1
kbd_col4	Keypad column 4	O	AE1/ E4
kbd_col5	Keypad column 5	O	AE2/ F5
kbd_col6	Keypad column 6	O	AE6/ E6
kbd_col7	Keypad column 7	O	AD2/ D3
kbd_col8	Keypad column 8	O	AD3/ D5

4.4.22 Pulse Width Modulation (PWM) Interface

注: For more information, see the Pulse-Width Modulation (PWM) SS section of the device TRM.

表 4-25. PWM Signal Descriptions

SIGNAL NAME	DESCRIPTION	TYPE	BALL
PWMSS1			
eQEP1A_in	EQEP1 Quadrature Input A	I	E1 / AD9
eQEP1B_in	EQEP1 Quadrature Input B	I	G2 / AF9
eQEP1_index	EQEP1 Index Input	IO	AE9 / H7
eQEP1_strobe	EQEP1 Strobe Input	IO	G1 / AF8
ehrpwm1A	EHRPWM1 Output A	O	AE8 / G6
ehrpwm1B	EHRPWM1 Output B	O	AD8 / F2
ehrpwm1_tripzone_in put	EHRPWM1 Trip Zone Input	IO	AG7 / F3
eCAP1_in_PWM1_out	ECAP1 Capture Input / PWM Output	IO	AH6 / D1
ehrpwm1_synci	EHRPWM1 Sync Input	I	AH3 / E2
ehrpwm1_synco	EHRPWM1 Sync Output	O	AH5 / D2
PWMSS2			
eQEP2A_in	EQEP2 Quadrature Input A	I	AG6 / F4
eQEP2B_in	EQEP2 Quadrature Input B	I	AH4 / C1
eQEP2_index	EQEP2 Index Input	IO	AG4 / E4
eQEP2_strobe	EQEP2 Strobe Input	IO	AG2 / F5
ehrpwm2A	EHRPWM2 Output A	O	AC5 / E6
ehrpwm2B	EHRPWM2 Output B	O	AB4 / D3
ehrpwm2_tripzone_in put	EHRPWM2 Trip Zone Input	IO	AD4 / F6
eCAP2_in_PWM2_out	ECAP2 Capture Input / PWM Output	IO	AC4 / D5
PWMSS3			
eQEP3A_in	EQEP3 Quadrature Input A	I	AC7 / C2
eQEP3B_in	EQEP3 Quadrature Input B	I	AC6 / C3
eQEP3_index	EQEP3 Index Input	IO	AC9 / C4
eQEP3_strobe	EQEP3 Strobe Input	IO	AC3 / B2
ehrpwm3A	EHRPWM3 Output A	O	AC8 / D6
ehrpwm3B	EHRPWM3 Output B	O	AD6 / C5
ehrpwm3_tripzone_in put	EHRPWM3 Trip Zone Input	IO	AB8 / A3
eCAP3_in_PWM3_out	ECAP3 Capture Input / PWM Output	IO	AB5 / B3

4.4.23 Audio Tracking Logic (ATL)

注: For more information, see the Audio Tracking Logic (ATL) section of the device TRM.

表 4-26. ATL Signal Descriptions

SIGNAL NAME	DESCRIPTION	TYPE	BALL
atl_clk0	Audio Tracking Logic Clock 0	O	D18
atl_clk1	Audio Tracking Logic Clock 1	O	E17

表 4-26. ATL Signal Descriptions (continued)

SIGNAL NAME	DESCRIPTION	TYPE	BALL
atl_clk2	Audio Tracking Logic Clock 2	O	B26
atl_clk3	Audio Tracking Logic Clock 3	O	C23

4.4.24 Test Interfaces

注意

The I/O timings provided in [7, Timing Requirements and Switching Characteristics](#) are valid only if signals within a single IOSET are used. The IOSETs are defined in the [表 7-151](#).

注: For more information, see the On-Chip Debug Support / Debug Ports section of the device TRM.

表 4-27. Debug Signal Descriptions

SIGNAL NAME	DESCRIPTION	TYPE	BALL
tms	JTAG test port mode select. An external pullup resistor should be used on this ball.	IO	F18
tdi	JTAG test data	I	D23
tdo	JTAG test port data	O	F19
tclk	JTAG test clock	I	E20
trstn	JTAG test reset	I	D20
rtck	JTAG return clock	O	E18
emu0 ⁽¹⁾	Emulator pin 0	IO	G21
emu1 ⁽¹⁾	Emulator pin 1	IO	D24
emu2	Emulator pin 2	O	F10
emu3	Emulator pin 3	O	D7
emu4	Emulator pin 4	O	A7
emu5	Emulator pin 5	O	E1 / G11
emu6	Emulator pin 6	O	G2 / E9
emu7	Emulator pin 7	O	H7 / F9
emu8	Emulator pin 8	O	G1 / F8
emu9	Emulator pin 9	O	G6 / E7
emu10	Emulator pin 10	O	F2 / D8
emu11	Emulator pin 11	O	F3 / A5
emu12	Emulator pin 12	O	D1 / C6
emu13	Emulator pin 13	O	E2 / C8
emu14	Emulator pin 14	O	D2 / C7
emu15	Emulator pin 15	O	F4 / A8
emu16	Emulator pin 16	O	C1 / C9
emu17	Emulator pin 17	O	E4 / A9
emu18	Emulator pin 18	O	F5 / B9
emu19	Emulator pin 19	O	E6 / A10

- (1) EMU0 and EMU1 are multiplexed with GPIO. These pins will be sampled at reset release by the test and emulation logic. Therefore, if they are used as GPIO pins, they must return to the high state whenever the device enters reset. This can be controlled by logic driven from rstoutn. After the device exits reset (indicated by rstoutn rising), these can return to GPIO mode.

4.4.25 System and Miscellaneous

4.4.25.1 Sysboot

注: For more information, see the Initialization (ROM Code) section of the device TRM.

表 4-28. Sysboot Signal Descriptions

SIGNAL NAME	DESCRIPTION	TYPE	BALL
sysboot0	Boot Mode Configuration 0. The value latched on this pin upon porz reset release will determine the boot mode configuration of the device.	I	M6
sysboot1	Boot Mode Configuration 1. The value latched on this pin upon porz reset release will determine the boot mode configuration of the device.	I	M2
sysboot2	Boot Mode Configuration 2. The value latched on this pin upon porz reset release will determine the boot mode configuration of the device.	I	L5
sysboot3	Boot Mode Configuration 3. The value latched on this pin upon porz reset release will determine the boot mode configuration of the device.	I	M1
sysboot4	Boot Mode Configuration 4. The value latched on this pin upon porz reset release will determine the boot mode configuration of the device.	I	L6
sysboot5	Boot Mode Configuration 5. The value latched on this pin upon porz reset release will determine the boot mode configuration of the device.	I	L4
sysboot6	Boot Mode Configuration 6. The value latched on this pin upon porz reset release will determine the boot mode configuration of the device.	I	L3
sysboot7	Boot Mode Configuration 7. The value latched on this pin upon porz reset release will determine the boot mode configuration of the device.	I	L2
sysboot8	Boot Mode Configuration 8. The value latched on this pin upon porz reset release will determine the boot mode configuration of the device.	I	L1
sysboot9	Boot Mode Configuration 9. The value latched on this pin upon porz reset release will determine the boot mode configuration of the device.	I	K2
sysboot10	Boot Mode Configuration 10. The value latched on this pin upon porz reset release will determine the boot mode configuration of the device.	I	J1
sysboot11	Boot Mode Configuration 11. The value latched on this pin upon porz reset release will determine the boot mode configuration of the device.	I	J2
sysboot12	Boot Mode Configuration 12. The value latched on this pin upon porz reset release will determine the boot mode configuration of the device.	I	H1
sysboot13	Boot Mode Configuration 13. The value latched on this pin upon porz reset release will determine the boot mode configuration of the device.	I	J3
sysboot14	Boot Mode Configuration 14. The value latched on this pin upon porz reset release will determine the boot mode configuration of the device.	I	H2
sysboot15	Boot Mode Configuration 15. The value latched on this pin upon porz reset release will determine the boot mode configuration of the device.	I	H3

4.4.25.2 Power, Reset, and Clock Management (PRCM)

注: For more information, see PRCM section of the device TRM.

表 4-29. PRCM Signal Descriptions

SIGNAL NAME	DESCRIPTION	TYPE	BALL
clkout1	Device Clock output 1. Can be used externally for devices with non-critical timing requirements, or for debug, or as a reference clock on GPMC as described in 表 7-26, <i>GPMC/NOR Flash Interface Switching Characteristics - Synchronous Mode - Default</i> and 表 7-28, <i>GPMC/NOR Flash Interface Switching Characteristics - Synchronous Mode - Alternate</i> .	O	F21 / P7
clkout2	Device Clock output 2. Can be used externally for devices with non-critical timing requirements, or for debug.	O	D18 / N1
clkout3	Device Clock output 3. Can be used externally for devices with non-critical timing requirements, or for debug.	O	C23
rstoutn	Reset out (Active low) output is asserted low whenever any global reset condition exists. After a brief delay, it will be set high upon removal of the internal global reset condition (porz, warm reset). It is only functional after its output buffer's reference voltage (vddshv3) is valid. If it is used as a reset for device peripheral components, then it should be AND gated with porz to avoid the possibility of reset signal glitches during a power up sequence. ⁽²⁾	O	F23
resetn	Reset (active low) input's falling edge can trigger a device warm reset state from an external component. This signal should be high prior to or simultaneous with, porz rising. If the signal is not used in the system, resetn should be pulled high with an external pull-up resistor to vddshv3.	I	E23
porz	Power on Reset (active low) input must be asserted low during a device power up sequence or cold reset state when all supplies are disabled. Typically, an external PMIC is the source and sets porz high after all supplies reach valid operating levels. Asserting porz low puts the entire device in a safe reset state.	I	F22
xref_clk0	External Reference Clock 0. For Audio and other Peripherals.	I	D18
xref_clk1	External Reference Clock 1. For Audio and other Peripherals.	I	E17
xref_clk2	External Reference Clock 2. For Audio and other Peripherals.	I	B26
xref_clk3	External Reference Clock 3. For Audio and other Peripherals.	I	C23
xi_osc0	System Oscillator OSC0 Crystal input / LVCMOS clock input. Functions as the input connection to a crystal when the internal oscillator OSC0 is used. Functions as an LVCMOS-compatible input clock when an external oscillator is used.	I	AE15
xo_osc0	System Oscillator OSC0 Crystal output	O	AD15
xi_osc1	Auxiliary Oscillator OSC1 Crystal input / LVCMOS clock input. Functions as the input connection to a crystal when the internal oscillator OSC1 is used. Functions as an LVCMOS-compatible input clock when an external oscillator is used	I	AC15
xo_osc1	Auxiliary Oscillator OSC1 Crystal output	O	AC13
RMII_MHZ_50_C LK ⁽¹⁾	RMII Reference Clock (50MHz). This pin is an input when external reference is used or output when internal reference is used.	IO	U3

(1) This clock signal is implemented as 'pad loopback' inside the device - the output signal is looped back through the input buffer to serve as the internal reference signal. Series termination is recommended (as close to device pin as possible) to improve signal integrity of the clock input. Any non-monotonicity in voltage that occurs at the pad loopback clock pin between V_{IH} and V_{IL} must be less than V_{HYS} .

(2) Note that rstoutn is only valid after vddshv3 is valid. If the rstoutn signal will be used as a reset into other devices attached to the SOC, it must be AND'ed with porz. This will prevent glitches occurring during supply ramping being propagated.

4.4.25.3 Real Time Clock (RTC) Interface

注: For more information, see the Real Time Clock (RTC) SS section of the device TRM.

表 4-30. RTC Signal Descriptions

SIGNAL NAME	DESCRIPTION	TYPE	BALL
Wakeup0	RTC External Wakeup Input 0	I	AD17
Wakeup1	RTC External Wakeup Input 1	I	AC17
Wakeup2	RTC External Wakeup Input 2	I	AB16
Wakeup3	RTC External Wakeup Input 3	I	AC16
rtc_porz	RTC Power Domain Power-On Reset Input	I	AB17

表 4-30. RTC Signal Descriptions (continued)

SIGNAL NAME	DESCRIPTION	TYPE	BALL
rtc_osc_xi_clk32	RTC Oscillator Input. Crystal connection to internal RTC oscillator. Functions as an RTC clock input when an external oscillator is used.	I	AE14
rtc_osc_xo	RTC Oscillator Output	O	AD14
rtc_iso ⁽¹⁾	RTC domain isolation signal.	I	AF14
on_off	RTC Power Enable output pin	O	Y11

(1) This signal must be kept 0 if device power supplies are not valid during RTC mode and 1 during normal operation. This can typically be achieved by connecting rtc_iso to the same signal driving porz (not rtc_porz) with appropriate voltage level translation if necessary.

4.4.25.4 System Direct Memory Access (SDMA)

注: For more information, see the DMA Controllers / System DMA section of the device TRM.

表 4-31. SDMA Signal Descriptions

SIGNAL NAME	DESCRIPTION	TYPE	BALL
dma_evt1	System DMA Event Input 1	I	P7 / P4
dma_evt2	System DMA Event Input 2	I	N1 / R3
dma_evt3	System DMA Event Input 3	I	N6
dma_evt4	System DMA Event Input 4	I	M4

4.4.25.5 Interrupt Controllers (INTC)

注: For more information, see the Interrupt Controllers section of the device TRM.

表 4-32. INTC Signal Descriptions

SIGNAL NAME	DESCRIPTION	TYPE	BALL
nmin_dsp	Non maskable interrupt input, active-low. This pin can be optionally routed to the DSP NMI input or as generic input to the Arm cores. Note that by default this pin has an internal pulldown resistor enabled. This internal pulldown should be disabled or countered by a stronger external pullup resistor before routing to the DSP or Arm processors.	I	D21
sys_nirq2	External interrupt event to any device INTC	I	AB16
sys_nirq1	External interrupt event to any device INTC	I	AC16

4.4.25.6 Observability

注: For more information, see the Control Module section of the device TRM.

表 4-33. Observability Signal Descriptions

SIGNAL NAME	DESCRIPTION	TYPE	BALL
obs0	Observation Output 0	O	F10
obs1	Observation Output 1	O	G11
obs2	Observation Output 2	O	E9
obs3	Observation Output 3	O	F9
obs4	Observation Output 4	O	F8
obs5	Observation Output 5	O	D7
obs6	Observation Output 6	O	D8

表 4-33. Observability Signal Descriptions (continued)

SIGNAL NAME	DESCRIPTION	TYPE	BALL
obs7	Observation Output 7	O	A5
obs8	Observation Output 8	O	C6
obs9	Observation Output 9	O	C8
obs10	Observation Output 10	O	C7
obs11	Observation Output 11	O	A7
obs12	Observation Output 12	O	A8
obs13	Observation Output 13	O	C9
obs14	Observation Output 14	O	A9
obs15	Observation Output 15	O	B9
obs16	Observation Output 16	O	F10
obs17	Observation Output 17	O	G11
obs18	Observation Output 18	O	E9
obs19	Observation Output 19	O	F9
obs20	Observation Output 20	O	F8
obs21	Observation Output 21	O	D7
obs22	Observation Output 22	O	D8
obs23	Observation Output 23	O	A5
obs24	Observation Output 24	O	C6
obs25	Observation Output 25	O	C8
obs26	Observation Output 26	O	C7
obs27	Observation Output 27	O	A7
obs28	Observation Output 28	O	A8
obs29	Observation Output 29	O	C9
obs30	Observation Output 30	O	A9
obs31	Observation Output 31	O	B9
obs_dmarq1	DMA Request External Observation Output 1	O	G11
obs_dmarq2	DMA Request External Observation Output 2	O	D8
obs_irq1	IRQ External Observation Output 1	O	F10
obs_irq2	IRQ External Observation Output 2	O	D7

4.4.26 Power Supplies

注: For more information, see Power, Reset, and Clock Management / PRCM Subsystem Environment / External Voltage Inputs section of the device TRM.

表 4-34. Power Supply Signal Descriptions

SIGNAL NAME	DESCRIPTION	TYPE	BALL
vdd	Core voltage domain supply	PWR	H13/ H14/ J17/ J18/ L7/ L8/ N10/ N13/ P11/ P12/ P13/ R11/ R16/ R19/ T13/ T16/ T19/ U8/ U9/ U13/ U16/ V8/ V16

表 4-34. Power Supply Signal Descriptions (continued)

SIGNAL NAME	DESCRIPTION	TYPE	BALL
vss	Ground	GND	A1/ A2/ A6/ A14/ A23/ A28/ B1/ D13/ D19/ E13/ E19/ F1/ F7/ G7/ G8/ G9/ H12/ J12/ J15/ J28/ K1/ K4/ K5/ K15/ K24/ K25/ L13/ L14/ M19/ N14/ N15/ N19/ N24/ N25/ P28/ R1/ R12/ R13/ R15/ R21/ T10/ T11/ T12/ T14/ T15/ T17/ T18/ T21/ U15/ U17/ U20/ U21/ V15/ V17/ W1/ W15/ W24/ W25/ W28/ AA8/ AA9/ AA10/ AA14/ AA15/ AA20/ AB14/ AB20/ AD1/ AD24/ AG1/ AH1/ AH2/ AH8/ AH20/ AH28
vdd_dspeve	DSP-EVE voltage domain supply	PWR	J13/ K10/ K11/ K12/ K13/ L10/ L11/ L12/ M10/ M11/ M12/ M13
vdd_iva	IVA voltage domain supply	PWR	U18/ U19/ V18/ V19
vdd_gpu	GPU voltage domain supply	PWR	U11/ U12/ V10/ V11/ V14/ W10/ W11/ W13
vdd_mpu	MPU voltage domain supply	PWR	K17/ K18/ L15/ L16/ L17/ L18/ L19/ M15/ M16/ M17/ M18/ N17/ N18/ P17/ P18/ R18
vdd_rtc	RTC voltage domain supply	PWR	AB15
vdda_usb1	DPLL_USB and HS USB1 1.8V analog power supply	PWR	AA13
vssa_usb	HS USB1 and HS USB2 analog ground	GND	AB11/ AA11
vdda_usb2	HS USB2 1.8V analog power supply	PWR	AB12
vdda33v_usb1	HS USB1 3.3V analog power supply. If USB1 is not used, this pin can alternatively be connected to VSS if the following requirements are met: - The usb1_dm/usb1_dp pins are left unconnected - The USB1 PHY is kept powered down	PWR	AA12
vdda33v_usb2	HS USB2 3.3V analog power supply. If USB2 is not used, this pin can alternatively be connected to VSS if the following requirements are met: - The usb2_dm/usb2_dp pins are left unconnected - The USB2 PHY is kept powered down	PWR	Y12
vdda_abe_per	DPLL_ABE, DPLL_PER, and PER HSDIVIDER analog power supply	PWR	M14
vdda_ddr	DPLL_DDR and DDR HSDIVIDER analog power supply	PWR	P16
vdda_debug	DPLL_DEBUG analog power supply	PWR	N11
vdda_dsp_eve	DPLL_DSP and DPLL_EVE analog power supply	PWR	N12
vdda_gmac_core	DPLL_CORE and CORE HSDIVIDER analog power supply	PWR	P15
vdda_gpu	DPLL_GPU analog power supply	PWR	R14
vdda_hdmi	PLL_HDMI and HDMI analog power supply	PWR	Y17
vssa_hdmi	DPLL_HDMI and HDMI PHY analog ground	GND	AE19 / AD19
vdda_iva	DPLL_IVA analog power supply	PWR	R17
vdda_pcie	DPLL_PCIE_REF and PCIe analog power supply	PWR	W14
vssa_pcie	PCIe analog ground	GND	AE13 / AD13
vdda_pcie0	PCIe ch0 RX/TX analog power supply	PWR	AA17
vdda_pcie1	PCIe ch1 RX/TX analog power supply	PWR	AA16
vdda_sata	DPLL_SATA and SATA RX/TX analog power supply	PWR	V13

表 4-34. Power Supply Signal Descriptions (continued)

SIGNAL NAME	DESCRIPTION	TYPE	BALL
vssa_sata	SATA analog ground	GND	AE10
vdda_usb3	DPLL_USB_OTG_SS and USB3.0 RX/TX analog power supply	PWR	W12
vssa_usb3	DPLL_USB and USB3.0 RX/TX analog ground	GND	AD10
vdda_video	DPLL_VIDEO1 and DPLL_VIDEO2 analog power supply	PWR	P14
vssa_video	DPLL_VIDEO1 and DPLL_VIDEO2 analog ground	GND	U14
vdds_mlbp	MLBP IO power supply	PWR	AA7 / Y7
vdda_mpu	DPLL_MPU analog power supply	PWR	N16
vdda_osc	HFOSC analog power supply	PWR	AE16 / AD16
vssa_osc0	OSC0 analog ground	GND	AF15
vssa_osc1	OSC1 analog ground	GND	AC14
vdda_rtc	RTC bias and RTC LFOSC analog power supply	PWR	AB13
vdds18v	1.8V power supply	PWR	W17/ W18/ V21/ V22/ T8/ R8/ P8/ N8/ M8/ M9/ H17/ G18
vdds18v_ddr1	DDR1 bias power supply	PWR	AA18/ AA19/ Y21/ W21
vdds18v_ddr2	DDR2 bias power supply	PWR	P20/ P21/ N21/ J21/ J22
vdds_ddr2	DDR2 power supply (1.8V for DDR2 mode / 1.5V for DDR3 mode / 1.35V DDR3L mode)	PWR	T24/ T25/ M20/ M21/ L20/ L21/ J27/ H20/ H21/ H22/ G22/ G23/ E24
vdds_ddr1	DDR1 power supply (1.8V for DDR2 mode / 1.5V for DDR3 mode / 1.35V DDR3L mode)	PWR	AH27/ AG20/ AG28/ AD26/ AC22/ AB21/ AB22/ AB24/ AB25/ AA21/ AA22/ W16/ W27
vddshv5	Dual Voltage (1.8V or 3.3V) power supply for the RTC Power Group pins	PWR	V12
vddshv1	Dual Voltage (1.8V or 3.3V) power supply for the VIN2 Power Group pins	PWR	H8/ H9/ G4/ G5/ E3/ E5
vddshv10	Dual Voltage (1.8V or 3.3V) power supply for the GPMC Power Group pins	PWR	T4/ T5/ R7/ R10/ P10/ N4/ N5
vddshv11	Dual Voltage (1.8V or 3.3V) power supply for the MMC2 Power Group pins	PWR	K8/ J8
vddshv2	Dual Voltage (1.8V or 3.3V) power supply for the VOUT Power Group pins	PWR	H10/ H11/ E10/ D10/ B6
vddshv3	Dual Voltage (1.8V or 3.3V) power supply for the GENERAL Power Group pins	PWR	H15/ H16/ H18/ H19/ G15/ E16/ E22/ D16/ D22/ B23
vddshv4	Dual Voltage (1.8V or 3.3V) power supply for the MMC4 Power Group pins	PWR	C24
vddshv6	Dual Voltage (1.8V or 3.3V) power supply for the VIN1 Power Group pins	PWR	AF5/ AE7/ AD5/ AD7
vddshv7	Dual Voltage (1.8V or 3.3V) power supply for the WIFI Power Group pins	PWR	AB6 / AB7
vddshv8	Dual Voltage (1.8V or 3.3V) power supply for the MMC1 Power Group pins	PWR	Y8 / W8
vddshv9	Dual Voltage (1.8V or 3.3V) power supply for the RGMII Power Group pins	PWR	W4/ W5/ U10
cap_vddram_dspeve2 ⁽¹⁾	External capacitor connection for the DSP-EVE SRAM array Ido2 output	CAP	J9
cap_vddram_dspeve1 ⁽¹⁾	External capacitor connection for the DSP-EVE SRAM array Ido1 output	CAP	J10
cap_vbbldo_mpu ⁽¹⁾	External capacitor connection for the MPU vbb Ido output	CAP	J16

表 4-34. Power Supply Signal Descriptions (continued)

SIGNAL NAME	DESCRIPTION	TYPE	BALL
cap_vddram_core2 ⁽¹⁾	External capacitor connection for the Core SRAM array ldo2 output	CAP	J19
cap_vbbldo_dspeve ⁽¹⁾	External capacitor connection for the DSP-EVE vbb ldo output	CAP	K9
cap_vddram_mpu1 ⁽¹⁾	External capacitor connection for the MPU SRAM array ldo1 output	CAP	K16
cap_vddram_mpu2 ⁽¹⁾	External capacitor connection for the MPU SRAM array ldo2 output	CAP	K19
cap_vddram_core1 ⁽¹⁾	External capacitor connection for the Core SRAM array ldo1 output	CAP	L9
cap_vddram_core4 ⁽¹⁾	External capacitor connection for the Core SRAM array ldo4 output	CAP	P19
cap_vbbldo_iva ⁽¹⁾	External capacitor connection for the IVA vbb ldo output	CAP	R20
cap_vddram_iva ⁽¹⁾	External capacitor connection for the IVA SRAM array ldo output	CAP	T20
cap_vddram_gpu ⁽¹⁾	External capacitor connection for the GPU SRAM array ldo output	CAP	Y13
cap_vbbldo_gpu ⁽¹⁾	External capacitor connection for the GPU vbb ldo output	CAP	Y14
cap_vddram_core3 ⁽¹⁾	External capacitor connection for the Core SRAM array ldo3 output	CAP	Y15
cap_vddram_core5 ⁽¹⁾	External capacitor connection for the Core SRAM array ldo5 output	CAP	Y16

(1) This pin must always be connected via a 1-uF capacitor to vss.

5 Specifications

注: For more information, see Power, Reset, and Clock Management / PRCM Subsystem Environment / External Voltage Inputs or Initialization / Preinitialization / Power Requirements section of the Device TRM.

注: The index numbers 1 and 2 which are part of the EMIF1 and EMIF2 signal prefixes (ddr1_* and ddr2_*) listed in 表 4-7, EMIF Signal Descriptions, not to be confused with DDR1 and DDR2 types of SDRAM memories.

注: Audio Back End (ABE) module is not supported for this family of devices, but “ABE” name is still present in some clock or DPLL names.

注意

All IO Cells are NOT Fail-safe compliant and should not be externally driven in absence of their IO supply.

5.1 Absolute Maximum Ratings

Stresses beyond those listed as absolute maximum ratings may cause permanent damage to the device. These are stress ratings only, and functional operation of the device at these or any other conditions beyond those listed under 5.4, *Recommended Operating Conditions*, is not implied. Exposure to absolute maximum rated conditions for extended periods may affect device reliability.

表 5-1. Absolute Maximum Rating Over Junction Temperature Range

PARAMETER ⁽¹⁾		MIN	MAX	UNIT	
V _{SUPPLY} (Steady-State)	Supply Voltage Ranges (Steady-State)	Core (vdd, vdd_mpu, vdd_gpu, vdd_dspeve, vdd_iva, vdd_rtc)	-0.3	1.5	V
	Analog (vdda_usb1, vdda_usb2, vdda_abe_per, vdda_ddr, vdda_debug, vdda_dsp_eve, vdda_gmac_core, vdda_gpu, vdda_hdmi, vdda_iva, vdda_pcie, vdda_pcie0, vdda_pcie1, vdda_sata, vdda_usb3, vdda_video, vdda_mpu, vdda_osc, vdda_rtc)	-0.3	2.0	V	
	Analog 3.3V (vdda33v_usb1, vdda33v_usb2)	-0.3	3.8	V	
	vdds18v, vdds18v_ddr1, vdds18v_ddr2, vdds_mlbp, vdds_ddr1, vdds_ddr2	-0.3	2.1	V	
	vddshv1-11 (1.8V mode)	-0.3	2.1	V	
	vddshv1-7 (3.3V mode), vddshv9-11 (3.3V mode)	-0.3	3.8	V	
	vddshv8 (3.3V mode)	-0.3	3.6	V	

表 5-1. Absolute Maximum Rating Over Junction Temperature Range (continued)

PARAMETER ⁽¹⁾		MIN	MAX	UNIT	
V _{IO} (Steady-State)	Input and Output Voltage Ranges (Steady-State)	Core I/Os	-0.3	1.5	V
		Analog I/Os (except HDMI)	-0.3	2.0	V
		HDMI I/Os	-0.3	3.5	V
		I/O 1.35V	-0.3	1.65	V
		I/O 1.5V	-0.3	1.8	V
		1.8V I/Os	-0.3	2.1	V
		3.3V I/Os (except those powered by vddshv8)	-0.3	3.8	V
		3.3V I/Os (powered by vddshv8)	-0.3	3.6	V
SR	Maximum slew rate, all supplies		10 ⁵	V/s	
V _{IO} (Transient Overshoot / Undershoot)	Input and Output Voltage Ranges (Transient Overshoot/Undershoot) Note: valid for up to 20% of the signal period. See 图 5-1, IO transient voltage ranges		0.2*VDD ⁽²⁾	V	
T _J	Operating junction temperature range	Automotive	-40	125	°C
T _{STG}	Storage temperature range after soldered onto PC Board		-55	+150	°C
Latch-up I-Test	I-test ⁽³⁾ , All I/Os (if different levels then one line per level)		-100	100	mA
Latch-up OV-Test	Over-voltage Test ⁽⁴⁾ , All supplies (if different levels then one line per level)		N/A	1.5*V _{supply max}	V

- (1) See I/Os supplied by this power pin in 表 4-2 Ball Characteristics.
- (2) VDD is the voltage on the corresponding power-supply pin(s) for the IO.
- (3) Per JEDEC JESD78 at 125°C with specified I/O pin injection current and clamp voltage of 1.5 times maximum recommended I/O voltage and negative 0.5 times maximum recommended I/O voltage.
- (4) Per JEDEC JESD78 at 125°C.
- (5) The maximum valid input voltage on an IO pin cannot exceed 0.3 volts when the supply powering the IO is turned off. This requirement applies to all the IO pins which are not fail-safe and for all values of IO supply voltage. Special attention should be applied anytime peripheral devices are not powered from the same power sources used to power the respective IO supply. It is important the attached peripheral never sources a voltage outside the valid input voltage range, including power supply ramp-up and ramp-down sequences.

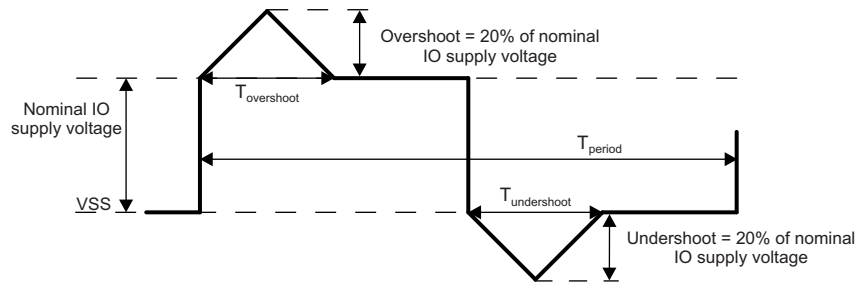

osus_spr851

(1) $T_{overshoot} + T_{undershoot} < 20\% \text{ of } T_{period}$

图 5-1. IO transient voltage ranges

5.2 ESD Ratings

表 5-2. ESD Ratings

		VALUE	UNIT	
V _(ESD)	Electrostatic discharge	Human-Body model (HBM), per AEC Q100-002 ⁽¹⁾	±1000	
		Charged-device model (CDM), per AEC Q100-011	All pins	±250
			Corner pins (A1, AH1, A28, AH28)	±750
			V	

(1) AEC Q100-002 indicates that HBM stressing shall be in accordance with the ANSI/ESDA/JEDEC JS-001 specification.

5.3 Power on Hour (POH) Limits

The information in the section below is provided solely for your convenience and does not extend or modify the warranty provided under TI's standard terms and conditions for TI semiconductor products.

注: POH is a functional of voltage, temperature and time. Usage at higher voltages and temperatures will result in a reduction in POH to achieve the same reliability performance. For assessment of alternate use cases, contact your local TI representative.

表 5-3. Power on Hour (POH) Limits

IP	Duty Cycle	Voltage Domain	Voltage (V) (max)	Frequency (MHz) (max)	Tj(°C)	POH
Arm	70%	vdd_mpu	OPP_HIGH	1500	Automotive Profile ⁽¹⁾	20000
	30%	vdd_mpu	Retention	0		
	40%	vdd_mpu	OPP_HIGH	1500	Automotive Profile ⁽¹⁾	20000
	60%	vdd_mpu	OPP_HIGH	1000	Automotive Profile ⁽¹⁾	20000
	55%	vdd_mpu	OPP_HIGH	1500		
	45%	vdd_mpu	OPP_NOM	1000		
	100%	vdd_mpu	OPP_HIGH	1176	Automotive Profile ⁽¹⁾	20000
100%	vdd_mpu	OPP_NOM	1000	Automotive Profile ⁽¹⁾	20000	
Others ⁽²⁾	100%	All	All Support OPPs		Automotive Profile ⁽¹⁾	20000

(1) Automotive profile is defined as 20000 power on hours with junction temperature as follows: 5%@-40°C, 65%@70°C, 20%@110°C, 10%@125°C.

(2) Others covers all other IP's voltage and temperature combinations that are not specified in the table, and are constrained by other sections of this data manual.

5.4 Recommended Operating Conditions

The device is used under the recommended operating conditions described in 表 5-4.

注: Logic functions and parameter values are not assured out of the range specified in the recommended operating conditions.

表 5-4. Recommended Operating Conditions

PARAMETER	DESCRIPTION	MIN ⁽²⁾	NOM	MAX DC ⁽³⁾	MAX ⁽²⁾	UNIT
Input Power Supply Voltage Range						
vdd	Core voltage domain supply		See 5.5			V
vdd_mpu	Supply voltage range for MPU domain		See 5.5			V
vdd_gpu	GPU voltage domain supply		See 5.5			V
vdd_dspeve	DSP-EVE voltage domain supply		See 5.5			V
vdd_iva	IVA voltage domain supply		See 5.5			V
vdd_rtc	RTC voltage domain supply		See 5.5			V
vdda_usb1	DPLL_USB and HS USB1 1.8V analog power supply	1.71	1.80	1.836	1.89	V
	Maximum noise (peak-peak)		50			mV _{PPmax}
vdda_usb2	HS USB2 1.8V analog power supply	1.71	1.80	1.836	1.89	V
	Maximum noise (peak-peak)		50			mV _{PPmax}
vdda33v_usb1	HS USB1 3.3V analog power supply. If USB1 is not used, this pin can alternatively be connected to VSS if the following requirements are met: - The usb1_dm/usb1_dp pins are left unconnected - The USB1 PHY is kept powered down	3.135	3.3	3.366	3.465	V
	Maximum noise (peak-peak)		50			mV _{PPmax}
vdda33v_usb2	HS USB2 3.3V analog power supply. If USB2 is not used, this pin can alternatively be connected to VSS if the following requirements are met: - The usb2_dm/usb2_dp pins are left unconnected - The USB2 PHY is kept powered down	3.135	3.3	3.366	3.465	V
	Maximum noise (peak-peak)		50			mV _{PPmax}
vdda_abe_per	DPLL_ABE, DPLL_PER, and PER HSDIVIDER analog power supply	1.71	1.80	1.836	1.89	V
	Maximum noise (peak-peak)		50			mV _{PPmax}
vdda_ddr	DPLL_DDR and DDR HSDIVIDER analog power supply	1.71	1.80	1.836	1.89	V
	Maximum noise (peak-peak)		50			mV _{PPmax}
vdda_debug	DPLL_DEBUG analog power supply	1.71	1.80	1.836	1.89	V
	Maximum noise (peak-peak)		50			mV _{PPmax}
vdda_dsp_eve	DPLL_DSP and DPLL_EVE analog power supply	1.71	1.80	1.836	1.89	V
	Maximum noise (peak-peak)		50			mV _{PPmax}
vdda_gmac_core	DPLL_CORE and CORE HSDIVIDER analog power supply	1.71	1.80	1.836	1.89	V
	Maximum noise (peak-peak)		50			mV _{PPmax}
vdda_gpu	DPLL_GPU analog power supply	1.71	1.80	1.836	1.89	V
	Maximum noise (peak-peak)		50			mV _{PPmax}

表 5-4. Recommended Operating Conditions (continued)

PARAMETER	DESCRIPTION	MIN ⁽²⁾	NOM	MAX DC ⁽³⁾	MAX ⁽²⁾	UNIT	
vdda_hdmi	PLL_HDMI and HDMI analog power supply	1.71	1.80	1.836	1.89	V	
	Maximum noise (peak-peak)		50			mV _{PPmax}	
vdda_iva	DPLL_IVA analog power supply	1.71	1.80	1.836	1.89	V	
	Maximum noise (peak-peak)		50			mV _{PPmax}	
vdda_pcie	DPLL_PCIE_REF and PCIe analog power supply	1.71	1.80	1.836	1.89	V	
	Maximum noise (peak-peak)		50			mV _{PPmax}	
vdda_pcie0	PCIe ch0 RX/TX analog power supply	1.71	1.80		1.89	V	
	Maximum noise (peak-peak)		50			mV _{PPmax}	
vdda_pcie1	PCIe ch1 RX/TX analog power supply	1.71	1.80		1.89	V	
	Maximum noise (peak-peak)		50			mV _{PPmax}	
vdda_sata	DPLL_SATA and SATA RX/TX analog power supply	1.71	1.80	1.836	1.89	V	
	Maximum noise (peak-peak)		50			mV _{PPmax}	
vdda_usb3	DPLL_USB_OTG_SS and USB3.0 RX/TX analog power supply	1.71	1.80	1.836	1.89	V	
	Maximum noise (peak-peak)		50			mV _{PPmax}	
vdda_video	DPLL_VIDEO1 and DPLL_VIDEO2 analog power supply	1.71	1.80	1.836	1.89	V	
	Maximum noise (peak-peak)		50			mV _{PPmax}	
vdds_mlbp	MLBP IO power supply	1.71	1.80		1.89	V	
	Maximum noise (peak-peak)		50			mV _{PPmax}	
vdda_mpu	DPLL_MPU analog power supply	1.71	1.80	1.836	1.89	V	
	Maximum noise (peak-peak)		50			mV _{PPmax}	
vdda_osc	HFOOSC analog power supply	1.71	1.80		1.89	V	
	Maximum noise (peak-peak)		50			mV _{PPmax}	
vdda_rtc	RTC bias and RTC LFOOSC analog power supply	1.71	1.80		1.89	V	
	Maximum noise (peak-peak)		50			mV _{PPmax}	
vdds18v	1.8V power supply	1.71	1.80	1.836	1.89	V	
	Maximum noise (peak-peak)		50			mV _{PPmax}	
vdds18v_dds1 ⁽⁴⁾	DDR1 bias power supply	1.71	1.80	1.836	1.89	V	
	Maximum noise (peak-peak)		50			mV _{PPmax}	
vdds18v_dds2 ⁽⁴⁾	DDR2 bias power supply	1.71	1.80	1.836	1.89	V	
	Maximum noise (peak-peak)		50			mV _{PPmax}	
vdds_dds1 ⁽⁴⁾	DDR1 power supply (1.8V for DDR2 mode / 1.5V for DDR3 mode / 1.35V DDR3L mode)	1.35-V Mode	1.28	1.35	1.377	1.42	V
		1.5-V Mode	1.43	1.50	1.53	1.57	
		1.8-V Mode	1.71	1.80	1.836	1.89	
	Maximum noise (peak-peak)	1.35-V Mode			50		mV _{PPmax}
		1.5-V Mode					
		1.8-V Mode					

表 5-4. Recommended Operating Conditions (continued)

PARAMETER	DESCRIPTION	MIN ⁽²⁾	NOM	MAX DC ⁽³⁾	MAX ⁽²⁾	UNIT	
vdds_ddr2 (4)	DDR2 power supply (1.8V for DDR2 mode/ 1.5V for DDR3 mode / 1.35V DDR3L mode)	1.35-V Mode	1.28	1.35	1.377	1.42	V
		1.5-V Mode	1.43	1.50	1.53	1.57	
		1.8-V Mode	1.71	1.80	1.836	1.89	
	Maximum noise (peak-peak)	1.35-V Mode		50			mV _{PPmax}
		1.5-V Mode					
		1.8-V Mode					
vddshv5	Dual Voltage (1.8V or 3.3V) power supply for the RTC Power Group pins	1.8-V Mode	1.71	1.80	1.836	1.89	V
		3.3-V Mode	3.135	3.30	3.366	3.465	
	Maximum noise (peak-peak)	1.8-V Mode		50			mV _{PPmax}
		3.3-V Mode					
vddshv1	Dual Voltage (1.8V or 3.3V) power supply for the VIN2 Power Group pins	1.8-V Mode	1.71	1.80	1.836	1.89	V
		3.3-V Mode	3.135	3.30	3.366	3.465	
	Maximum noise (peak-peak)	1.8-V Mode		50			mV _{PPmax}
		3.3-V Mode					
vddshv10	Dual Voltage (1.8V or 3.3V) power supply for the GPMC Power Group pins	1.8-V Mode	1.71	1.80	1.836	1.89	V
		3.3-V Mode	3.135	3.30	3.366	3.465	
	Maximum noise (peak-peak)	1.8-V Mode		50			mV _{PPmax}
		3.3-V Mode					
vddshv11	Dual Voltage (1.8V or 3.3V) power supply for the MMC2 Power Group pins	1.8-V Mode	1.71	1.80	1.836	1.89	V
		3.3-V Mode	3.135	3.30	3.366	3.465	
	Maximum noise (peak-peak)	1.8-V Mode		50			mV _{PPmax}
		3.3-V Mode					
vddshv2	Dual Voltage (1.8V or 3.3V) power supply for the VOUT Power Group pins	1.8-V Mode	1.71	1.80	1.836	1.89	V
		3.3-V Mode	3.135	3.30	3.366	3.465	
	Maximum noise (peak-peak)	1.8-V Mode		50			mV _{PPmax}
		3.3-V Mode					
vddshv3	Dual Voltage (1.8V or 3.3V) power supply for the GENERAL Power Group pins	1.8-V Mode	1.71	1.80	1.836	1.89	V
		3.3-V Mode	3.135	3.30	3.366	3.465	
	Maximum noise (peak-peak)	1.8-V Mode		50			mV _{PPmax}
		3.3-V Mode					
vddshv4	Dual Voltage (1.8V or 3.3V) power supply for the MMC4 Power Group pins	1.8-V Mode	1.71	1.80	1.836	1.89	V
		3.3-V Mode	3.135	3.30	3.366	3.465	
	Maximum noise (peak-peak)	1.8-V Mode		50			mV _{PPmax}
		3.3-V Mode					

表 5-4. Recommended Operating Conditions (continued)

PARAMETER	DESCRIPTION		MIN ⁽²⁾	NOM	MAX DC ⁽³⁾	MAX ⁽²⁾	UNIT
vddshv6	Dual Voltage (1.8V or 3.3V) power supply for the VIN1 Power Group pins	1.8-V Mode	1.71	1.80	1.836	1.89	V
		3.3-V Mode	3.135	3.30	3.366	3.465	
	Maximum noise (peak-peak)	1.8-V Mode		50			mV _{PPmax}
		3.3-V Mode					
vddshv7	Dual Voltage (1.8V or 3.3V) power supply for the WIFI Power Group pins	1.8-V Mode	1.71	1.80	1.836	1.89	V
		3.3-V Mode	3.135	3.30	3.366	3.465	
	Maximum noise (peak-peak)	1.8-V Mode		50			mV _{PPmax}
		3.3-V Mode					
vddshv8	Dual Voltage (1.8V or 3.3V) power supply for the MMC1 Power Group pins	1.8-V Mode	1.71	1.80	1.836	1.89	V
		3.3-V Mode	3.135	3.30	3.366	3.465	
	Maximum noise (peak-peak)	1.8-V Mode		50			mV _{PPmax}
		3.3-V Mode					
vddshv9	Dual Voltage (1.8V or 3.3V) power supply for the RGMII Power Group pins	1.8-V Mode	1.71	1.80	1.836	1.89	V
		3.3-V Mode	3.135	3.30	3.366	3.465	
	Maximum noise (peak-peak)	1.8-V Mode		50			mV _{PPmax}
		3.3-V Mode					
vss	Ground supply		0			V	
vssa_hdmi	DPLL_HDMI and HDMI PHY analog ground		0			V	
vssa_pcie	PCIe analog ground		0			V	
vssa_usb	HS USB1 and HS USB2 analog ground		0			V	
vssa_usb3	DPLL_USB and USB3.0 RX/TX analog ground		0			V	
vssa_video	DPLL_VIDEO1 and DPLL_VIDEO2 analog ground		0			V	
vssa_osc0	OSC0 analog ground		0			V	
vssa_osc1	OSC1 analog ground		0			V	
T _J ⁽¹⁾	Operating junction temperature range	Automotive	-40			125 ⁽⁵⁾	°C
ddr1_vref0	Reference Power Supply DDR1			0.5*vdds_dds1			V
ddr2_vref0	Reference Power Supply DDR2			0.5*vdds_dds2			V

(1) Refer to Power on Hours table 表 5-3 for limitations.

(2) The voltage at the device ball should never be below the MIN voltage or above the MAX voltage for any amount of time. This requirement includes dynamic voltage events such as AC ripple, voltage transients, voltage dips, etc.

(3) The DC voltage at the device ball should never be above the MAX DC voltage to avoid impact on device reliability and lifetime POH (Power-On-Hours). The MAX DC voltage is defined as the highest allowed DC regulated voltage, without transients, seen at the ball.

(4) If DDR2 type of memories are used, the EMIF power supply (vdds_ddrx) and the corresponding bias power supply (vdds18v_ddrx) must be sourced from single power source.

(5) The TSHUT feature of the SoC resets the device by default when one of the on-die temp sensors reports 123°C. This is intended to protect the device from exceeding 125°C. Though not recommended, the TSHUT temperature threshold can be modified in software if other mechanisms are in place to avoid exceeding 125°C. Refer to the device TRM for details on the TSHUT feature.

5.5 Operating Performance Points

This section describes the operating conditions of the device. This section also contains the description of each OPP (operating performance point) for processor clocks and device core clocks.

表 5-5 describes the maximum supported frequency per speed grade for DRA75x/DRA74x devices.

表 5-5. Speed Grade Maximum Frequency

DEVICE SPEED	MAXIMUM FREQUENCY (MHz)								
	MPU	DSP	EVE	IVA	GPU	IPU	L3	DDR3/DDR3L	DDR2
DRA7xxxP	1500	750	650 ⁽¹⁾	532	532	212.8	266	532 (DDR3-1066)	400 (DDR2-800)
DRA7xxxL	1176	750	650 ⁽¹⁾	532	532	212.8	266	532 (DDR3-1066)	400 (DDR2-800)
DRA7xxxJ	1000	750	650 ⁽¹⁾	532	532	212.8	266	532 (DDR3-1066)	400 (DDR2-800)

(1) Applicable for DRA754, DRA755, and DRA756. Not Applicable for all other devices!

5.5.1 AVS and ABB Requirements

Adaptive Voltage Scaling (AVS) and Adaptive Body Biasing (ABB) are required on most of the vdd_* supplies as defined in 表 5-6.

表 5-6. AVS and ABB Requirements per vdd_* Supply

SUPPLY	AVS REQUIRED?	ABB REQUIRED?
vdd	Yes, for all OPPs	No
vdd_mpu	Yes, for all OPPs	Yes, for all OPPs
vdd_iva	Yes, for all OPPs	Yes, for all OPPs
vdd_dspeve	Yes, for all OPPs	Yes, for all OPPs
vdd_gpu	Yes, for all OPPs	Yes, for all OPPs
vdd_rtc	No	No

5.5.2 Voltage And Core Clock Specifications

表 5-7 shows the recommended OPP per voltage domain.

表 5-7. Voltage Domains Operating Performance Points

DOMAIN	CONDITION	OPP_NOM			OPP_OD			OPP_HIGH			
		MIN ⁽²⁾	NOM ⁽¹⁾	MAX ⁽²⁾	MIN ⁽²⁾	NOM ⁽¹⁾	MAX ⁽²⁾	MIN ⁽²⁾	NOM ⁽¹⁾	MAX DC ⁽³⁾	MAX ⁽²⁾
VD_CORE (V)	BOOT (Before AVS is enabled) ⁽⁴⁾	1.11	1.15	1.2	Not Applicable			Not Applicable			
	After AVS is enabled ⁽⁴⁾	AVS Voltage ⁽⁵⁾ – 3.5%	AVS Voltage ⁽⁵⁾	1.2	Not Applicable			Not Applicable			
VD_MPU (V)	BOOT (Before AVS is enabled) ⁽⁴⁾	1.11	1.15	1.2	Not Applicable			Not Applicable			
	After AVS is enabled ⁽⁴⁾	AVS Voltage ⁽⁵⁾ – 3.5%	AVS Voltage ⁽⁵⁾	1.2	AVS Voltage ⁽⁵⁾ – 3.5%	AVS Voltage ⁽⁵⁾	AVS Voltage ⁽⁵⁾ + 5%	AVS Voltage ⁽⁵⁾ – 3.5%	AVS Voltage ⁽⁵⁾	AVS Voltage ⁽⁵⁾ +2%	AVS Voltage ⁽⁵⁾ + 5%
VD_RTC (V) ⁽⁶⁾	-	0.84	0.88 to 1.06	1.16	Not Applicable			Not Applicable			
Others (V)	BOOT (Before AVS is enabled) ⁽⁴⁾	1.02	1.06	1.16	Not Applicable			Not Applicable			
	After AVS is enabled ⁽⁴⁾	AVS Voltage ⁽⁵⁾ – 3.5%	AVS Voltage ⁽⁵⁾	1.16	AVS Voltage ⁽⁵⁾ – 3.5%	AVS Voltage ⁽⁵⁾	AVS Voltage ⁽⁵⁾ + 5%	AVS Voltage ⁽⁵⁾ – 3.5%	AVS Voltage ⁽⁵⁾	AVS Voltage ⁽⁵⁾ +2%	AVS Voltage ⁽⁵⁾ + 5%

- (1) In a typical implementation, the power supply should target the NOM voltage.
- (2) The voltage at the device ball should never be below the MIN voltage or above the MAX voltage for any amount of time. This requirement includes dynamic voltage events such as AC ripple, voltage transients, voltage dips, etc.
- (3) The DC voltage at the device ball should never be above the MAX DC voltage to avoid impact on device reliability and lifetime POH (Power-On-Hours). The MAX DC voltage is defined as the highest allowed DC regulated voltage, without transients, seen at the ball.
- (4) For all OPPs, AVS must be enabled to avoid impact on device reliability, lifetime POH (Power-On-Hours), and device power.
- (5) The AVS Voltages are device-dependent, voltage domain-dependent, and OPP-dependent. They must be read from the STD_FUSE_OPP. For information about STD_FUSE_OPP Registers address, please refer to Control Module Section of the TRM. The power supply should be adjustable over the following ranges for each required OPP:
 - OPP_NOM for MPU: 0.85V – 1.15V
 - OPP_NOM for CORE and Others: 0.85V - 1.15V
 - OPP_OD: 0.885V - 1.15V
 - OPP_HIGH: 0.95V - 1.25V
 The AVS Voltages will be within the above specified ranges.
- (6) VD_RTC can optionally be tied to VD_CORE and operate at the VD_CORE AVS voltages.
- (7) The power supply must be programmed with the AVS voltages for the MPU and the CORE voltage domain, either just after the ROM boot or at the earliest possible time in the secondary boot loader before there is significant activity seen on these domains.

表 5-8 describes the standard processor clocks speed characteristics vs OPP of the device.

表 5-8. Supported OPP vs Max Frequency (2)

DESCRIPTION	OPP_NOM	OPP_OD	OPP_HIGH
	MAX FREQ. (MHz)	MAX FREQ. (MHz)	MAX FREQ. (MHz)
VD_MPU			
MPU_CLK	1000	1176	1500
VD_DSPEVE			
DSP_CLK	600	700	750
EVE_FCLK	535	650	650
VD_IVA			
IVA_GCLK	388.3	430	532
VD_GPU			
GPU_CLK	425.6	500	532
VD_CORE			
CORE_IPUx_CLK	212.8	N/A	N/A
L3_CLK	266	N/A	N/A
DDR2	400 (DDR2-800)	N/A	N/A
DDR3 / DDR3L	532 (DDR3-1066)	N/A	N/A
VD_RTC			
RTC_FCLK	0.034	N/A	N/A

(1) N/A in this table stands for Not Applicable.

(2) Maximum supported frequency is limited according to 表 5-5, *Speed Grade Maximum Frequency*).

5.5.3 Maximum Supported Frequency

Device modules either receive their clock directly from an external clock input, directly from a PLL, or from a PRCM. 表 5-9 lists the clock source options for each module on this device, along with the maximum frequency that module can accept. To ensure proper module functionality, the device PLLs and dividers must be programmed not to exceed the maximum frequencies listed in this table.

表 5-9. Maximum Supported Frequency

Module				Clock Sources		
Instance Name	Input Clock Name	Clock Type	Max. Clock Allowed (MHz)	PRCM Clock Name	PLL / OSC / Source Clock Name	PLL / OSC / Source Name
AES1	AES1_L3_CLK	Int	266	L4SEC_L3_GICKL	CORE_X2_CLK	DPLL_CORE

表 5-9. Maximum Supported Frequency (continued)

Module				Clock Sources		
Instance Name	Input Clock Name	Clock Type	Max. Clock Allowed (MHz)	PRCM Clock Name	PLL / OSC / Source Clock Name	PLL / OSC / Source Name
AES2	AES2_L3_CLK	Int	266	L4SEC_L3_GICLK	CORE_X2_CLK	DPLL_CORE
ATL	ATL_ICLK_L3	Int	266	ATL_L3_GICLK	CORE_X2_CLK	DPLL_CORE
	ATLPCLK	Func	266	ATL_GFCLK	CORE_X2_CLK	DPLL_CORE
					PER_ABE_X1_GFCLK	DPLL_ABE
					FUNC_32K_CLK	OSC1
						RTC Oscillator
					VIDEO1_CLK	DPLL_VIDEO1
VIDEO2_CLK					DPLL_VIDEO2	
	HDMI_CLK	DPLL_HDMI				
BB2D	BB2D_FCLK	Func	354.6	BB2D_GFCLK	BB2D_GFCLK	DPLL_CORE
	BB2D_ICLK	Int	266	DSS_L3_GICLK	CORE_X2_CLK	DPLL_CORE
COUNTER_32K	COUNTER_32K_FCLK	Func	0.032	FUNC_32K_CLK	SYS_CLK1/610	OSC1
	COUNTER_32K_ICLK	Int	38.4	WKUPAON_GICLK	SYS_CLK1	OSC1
CTRL_MODULE_BANDGAP	L3INSTR_TS_GCLK	Int	4.8	L3INSTR_TS_GCLK	SYS_CLK1	OSC1
					DPLL_ABE_X2_CLK	DPLL_ABE
CTRL_MODULE_CORE	L4CFG_L4_GICLK	Int	133	L4CFG_L4_GICLK	CORE_X2_CLK	DPLL_CORE
CTRL_MODULE_WKUP	WKUPAON_GICLK	Int	38.4	WKUPAON_GICLK	SYS_CLK1	OSC1
					DPLL_ABE_X2_CLK	DPLL_ABE
DCAN1	DCAN1_FCLK	Func	38.4	DCAN1_SYS_CLK	SYS_CLK1	OSC1
					SYS_CLK2	OSC2
DCAN1	DCAN1_ICLK	Int	266	WKUPAON_GICLK	SYS_CLK1	OSC1
					DPLL_ABE_X2_CLK	DPLL_ABE
DCAN2	DCAN2_FCLK	Func	38.4	DCAN2_SYS_CLK	SYS_CLK1	OSC1
	DCAN2_ICLK	Int	266	L4PER2_L3_GICLK	CORE_X2_CLK	DPLL_CORE
DES3DES	DES_CLK_L3	Int	266	L4SEC_L3_GICLK	CORE_X2_CLK	DPLL_CORE
DLL	EMIF_DLL_FCLK	Func	EMIF_DLL_FCLK	EMIF_DLL_GCLK	EMIF_DLL_GCLK	DPLL_DDR
DLL_AGING	FCLK	Int	38.4	L3INSTR_DLL_AGING_GCLK	SYS_CLK1	OSC1
					DPLL_ABE_X2_CLK	DPLL_ABE
DMA_CRYPTO	DMA_CRYPTO_FCLK	Int & Func	266	L4SEC_L3_GICLK	CORE_X2_CLK	DPLL_CORE
	DMA_CRYPTO_ICLK	Int	133	L4SEC_L4_GICLK	CORE_X2_CLK	DPLL_CORE
DMM	DMM_CLK	Int	266	EMIF_L3_GICLK	CORE_X2_CLK	DPLL_CORE
DPLL_DEBUG	SYSCLK	Int	38.4	EMU_SYS_CLK	SYS_CLK1	OSC1
DSP1	DSP1_FICLK	Int & Func	DSP_CLK	DSP1_GFCLK	DSP_GFCLK	DPLL_DSP
DSP2	DSP2_FICLK	Int & Func	DSP_CLK	DSP2_GFCLK	DSP_GFCLK	DPLL_DSP

表 5-9. Maximum Supported Frequency (continued)

Module				Clock Sources		
Instance Name	Input Clock Name	Clock Type	Max. Clock Allowed (MHz)	PRCM Clock Name	PLL / OSC / Source Clock Name	PLL / OSC / Source Name
DSS	DSS_HDMI_CEC_CLK	Func	0.032	HDMI_CEC_GFCLK	SYS_CLK1/610	OSC1
	DSS_HDMI_PHY_CLK	Func	48	HDMI_PHY_GFCLK	FUNC_192M_CLK	DPLL_PER
	DSS_CLK	Func	192	DSS_GFCLK	DSS_CLK	DPLL_PER
	HDMI_CLKINP	Func	38.4	HDMI_DPLL_CLK	SYS_CLK1	OSC1
					SYS_CLK2	OSC2
	DSS_L3_ICLK	Int	266	DSS_L3_GICLK	CORE_X2_CLK	DPLL_CORE
	VIDEO1_CLKINP	Func	38.4	VIDEO1_DPLL_CLK	SYS_CLK1	OSC1
					SYS_CLK2	OSC2
	VIDEO2_CLKINP	Func	38.4	VIDEO2_DPLL_CLK	SYS_CLK1	OSC1
					SYS_CLK2	OSC2
	DPLL_DS11_A_CLK1	Func	209.3	N/A	HDMI_CLK	DPLL_HDMI
					VIDEO1_CLKOUT1	DPLL_VIDEO1
	DPLL_DS11_B_CLK1	Func	209.3	N/A	VIDEO1_CLKOUT3	DPLL_VIDEO1
					VIDEO2_CLKOUT3	DPLL_VIDEO2
					HDMI_CLK	DPLL_HDMI
DPLL_ABE_X2_CLK					DPLL_ABE	
DPLL_DS11_C_CLK1	Func	209.3	N/A	HDMI_CLK	DPLL_HDMI	
				VIDEO1_CLKOUT3	DPLL_VIDEO1	
				VIDEO2_CLKOUT1	DPLL_VIDEO2	
DPLL_HDMI_CLK1	Func	185.6	N/A	HDMI_CLK	DPLL_HDMI	
DSS DISPC	LCD1_CLK	Func	209.3	N/A	DPLL_DS11_A_CLK1	See DSS data in the rows above
					DSS_CLK	
	LCD2_CLK	Func	209.3	N/A	DPLL_DS11_B_CLK1	
					DSS_CLK	
	LCD3_CLK	Func	209.3	N/A	DPLL_DS11_C_CLK1	
					DSS_CLK	
	F_CLK	Func	209.3	N/A	DPLL_DS11_A_CLK1	
					DPLL_DS11_B_CLK1	
DPLL_DS11_C_CLK1						
DSS_CLK						
EFUSE_CTRL_CUST	ocp_clk	Int	133	CUSTEFUSE_L4_GICLK	CORE_X2_CLK	DPLL_CORE
	sys_clk	Func	38.4	CUSTEFUSE_SYS_GFCLK	SYS_CLK1	OSC1
ELM	ELM_ICLK	Int	266	L4PER_L3_GICLK	CORE_X2_CLK	DPLL_CORE
EMIF_OCP_FW	L3_CLK	Int	266	EMIF_L3_GICLK	CORE_X2_CLK	DPLL_CORE
EMIF_PHY1	EMIF_PHY1_FCLK	Func	DDR	EMIF_PHY_GCLK	EMIF_PHY_GCLK	DPLL_DDR
EMIF_PHY2	EMIF_PHY2_FCLK	Func	DDR	EMIF_PHY_GCLK	EMIF_PHY_GCLK	DPLL_DDR

表 5-9. Maximum Supported Frequency (continued)

Module				Clock Sources						
Instance Name	Input Clock Name	Clock Type	Max. Clock Allowed (MHz)	PRCM Clock Name	PLL / OSC / Source Clock Name	PLL / OSC / Source Name				
EMIF1	EMIF1_ICLK	Int	266	EMIF_L3_GICLK	CORE_X2_CLK	DPLL_CORE				
EMIF2	EMIF2_ICLK	Int	266	EMIF_L3_GICLK	CORE_X2_CLK	DPLL_CORE				
EVE1	EVE1_FCLK	Func	EVE_FCLK	EVE1_GFCLK	-	DPLL_DSP				
					EVE_GFCLK	DPLL_EVE				
EVE2	EVE2_FCLK	Func	EVE_FCLK	EVE2_GFCLK	-	DPLL_DSP				
					EVE_GFCLK	DPLL_EVE				
FPKA	PKA_CLK	Int & Func	266	L4SEC_L3_GICLK	CORE_X2_CLK	DPLL_CORE				
GMAC_SW	CPTS_RFT_CLK	Func	266	GMAC_RFT_CLK	PER_ABE_X1_GFCLK	DPLL_ABE				
					VIDEO1_CLK	DPLL_VIDEO1				
					VIDEO2_CLK	DPLL_VIDEO2				
					HDMI_CLK	DPLL_HDMI				
	MAIN_CLK	Int	125	GMAC_MAIN_CLK	GMAC_250M_CLK	DPLL_GMAC				
	MHZ_250_CLK	Func	250	GMII_250MHZ_CLK	GMII_250MHZ_CLK	DPLL_GMAC				
	MHZ_5_CLK	Func	5	RGMII_5MHZ_CLK	GMAC_RMII_HS_CLK	DPLL_GMAC				
	MHZ_50_CLK	Func	50	RMII_50MHZ_CLK	GMAC_RMII_HS_CLK	DPLL_GMAC				
	RMII1_MHZ_50_CLK	Func	50	RMII_50MHZ_CLK	GMAC_RMII_HS_CLK	DPLL_GMAC				
RMII2_MHZ_50_CLK	Func	50	RMII_50MHZ_CLK	GMAC_RMII_HS_CLK	DPLL_GMAC					
GPIO1	GPIO1_ICLK	Int	38.4	WKUPAON_GICLK	SYS_CLK1	OSC1				
					DPLL_ABE_X2_CLK	DPLL_ABE				
GPIO1	GPIO1_DBCLK	Func	0.032	WKUPAON_SYS_GFCCLK	WKUPAON_32K_GFCCLK	OSC1 RTC Oscillator				
GPIO2	GPIO2_ICLK	Int	266	L4PER_L3_GICLK	CORE_X2_CLK	DPLL_CORE				
					GPIO2_DBCLK	Func	0.032	GPIO_GFCLK	FUNC_32K_CLK	OSC1 RTC Oscillator
GPIO3	GPIO3_ICLK	Int	266	L4PER_L3_GICLK	CORE_X2_CLK	DPLL_CORE				
					GPIO3_DBCLK	Func	0.032	GPIO_GFCLK	FUNC_32K_CLK	OSC1 RTC Oscillator
GPIO4	GPIO4_ICLK	Int	266	L4PER_L3_GICLK	CORE_X2_CLK	DPLL_CORE				
					GPIO4_DBCLK	Func	0.032	GPIO_GFCLK	FUNC_32K_CLK	OSC1
					PIDBCLK	Func	0.032	GPIO_GFCLK		RTC Oscillator
GPIO5	GPIO5_ICLK	Int	266	L4PER_L3_GICLK	CORE_X2_CLK	DPLL_CORE				
					GPIO5_DBCLK	Func	0.032	GPIO_GFCLK	FUNC_32K_CLK	OSC1
					PIDBCLK	Func	0.032	GPIO_GFCLK		RTC Oscillator
GPIO6	GPIO6_ICLK	Int	266	L4PER_L3_GICLK	CORE_X2_CLK	DPLL_CORE				
					GPIO6_DBCLK	Func	0.032	GPIO_GFCLK	FUNC_32K_CLK	OSC1
					PIDBCLK	Func	0.032	GPIO_GFCLK		RTC Oscillator

表 5-9. Maximum Supported Frequency (continued)

Module				Clock Sources		
Instance Name	Input Clock Name	Clock Type	Max. Clock Allowed (MHz)	PRCM Clock Name	PLL / OSC / Source Clock Name	PLL / OSC / Source Name
GPIO7	GPIO7_ICLK	Int	266	L4PER_L3_GICLK	CORE_X2_CLK	DPLL_CORE
	GPIO7_DBCLK	Func	0.032	GPIO_GFCLK	FUNC_32K_CLK	OSC1
	PIDBCLK	Func	0.032	GPIO_GFCLK		RTC Oscillator
GPIO8	GPIO8_ICLK	Int	266	L4PER_L3_GICLK	CORE_X2_CLK	DPLL_CORE
	GPIO8_DBCLK	Func	0.032	GPIO_GFCLK	FUNC_32K_CLK	OSC1
	PIDBCLK	Func	0.032	GPIO_GFCLK		RTC Oscillator
GPMC	GPMC_FCLK	Int	266	L3MAIN1_L3_GICLK	CORE_X2_CLK	DPLL_CORE
GPU	GPU_FCLK1	Func	GPU_CLK	GPU_CORE_GCLK	CORE_GPU_CLK	DPLL_CORE
					PER_GPU_CLK	DPLL_PER
					GPU_GCLK	DPLL_GPU
	GPU_FCLK2	Func	GPU_CLK	GPU_HYD_GCLK	CORE_GPU_CLK	DPLL_CORE
					PER_GPU_CLK	DPLL_PER
					GPU_GCLK	DPLL_GPU
GPU_ICLK	Int	266	GPU_L3_GICLK	CORE_X2_CLK	DPLL_CORE	
HDMI PHY	DSS_HDMI_PHY_CLK	Func	38.4	HDMI_PHY_GFCLK	FUNC_192M_CLK	DPLL_PER
HDQ1W	HDQ1W_ICLK	Int & Func	266	L4PER_L3_GICLK	CORE_X2_CLK	DPLL_CORE
	HDQ1W_FCLK	Func	12	PER_12M_GFCLK	FUNC_192M_CLK	DPLL_PER
I2C1	I2C1_ICLK	Int	266	L4PER_L3_GICLK	CORE_X2_CLK	DPLL_CORE
	I2C1_FCLK	Func	96	PER_96M_GFCLK	FUNC_192M_CLK	DPLL_PER
I2C2	I2C2_ICLK	Int	266	L4PER_L3_GICLK	CORE_X2_CLK	DPLL_CORE
	I2C2_FCLK	Func	96	PER_96M_GFCLK	FUNC_192M_CLK	DPLL_PER
I2C3	I2C3_ICLK	Int	266	L4PER_L3_GICLK	CORE_X2_CLK	DPLL_CORE
	I2C3_FCLK	Func	96	PER_96M_GFCLK	FUNC_192M_CLK	DPLL_PER
I2C4	I2C4_ICLK	Int	266	L4PER_L3_GICLK	CORE_X2_CLK	DPLL_CORE
	I2C4_FCLK	Func	96	PER_96M_GFCLK	FUNC_192M_CLK	DPLL_PER
I2C5	I2C5_ICLK	Int	266	IPU_L3_GICLK	CORE_X2_CLK	DPLL_CORE
	I2C5_FCLK	Func	96	IPU_96M_GFCLK	FUNC_192M_CLK	DPLL_PER
IEEE1500_2_OCP	PI_L3CLK	Int & Func	266	L3INIT_L3_GICLK	CORE_X2_CLK	DPLL_CORE
IPU1	IPU1_GFCLK	Int & Func	425.6	IPU1_GFCLK	DPLL_ABE_X2_CLK	DPLL_ABE
					CORE_IPU_ISS_BOOST_CLK	DPLL_CORE
IPU2	IPU2_GFCLK	Int & Func	425.6	IPU2_GFCLK	CORE_IPU_ISS_BOOST_CLK	DPLL_CORE
IVA	IVA_GCLK	Int	IVA_GCLK	IVA_GCLK	IVA_GFCLK	DPLL_IVA
KBD	KBD_FCLK	Func	0.032	WKUPAON_SYS_GCLK	WKUPAON_32K_GFCLK	OSC1
	PICKKBD	Func	0.032	WKUPAON_SYS_GCLK		RTC Oscillator
	KBD_ICLK	Int	38.4	WKUPAON_GICLK	SYS_CLK1	OSC1
	PICKOCP	Int	38.4	WKUPAON_GICLK	DPLL_ABE_X2_CLK	DPLL_ABE
L3_INSTR	L3_CLK	Int	L3_CLK	L3INSTR_L3_GICLK	CORE_X2_CLK	DPLL_CORE
L3_MAIN	L3_CLK1	Int	L3_CLK	L3MAIN1_L3_GICLK	CORE_X2_CLK	DPLL_CORE
	L3_CLK2	Int	L3_CLK	L3INSTR_L3_GICLK	CORE_X2_CLK	DPLL_CORE

表 5-9. Maximum Supported Frequency (continued)

Module				Clock Sources		
Instance Name	Input Clock Name	Clock Type	Max. Clock Allowed (MHz)	PRCM Clock Name	PLL / OSC / Source Clock Name	PLL / OSC / Source Name
L4_CFG	L4_CFG_CLK	Int	133	L4CFG_L3_GICK	CORE_X2_CLK	DPLL_CORE
L4_PER1	L4_PER1_CLK	Int	133	L4PER_L3_GICK	CORE_X2_CLK	DPLL_CORE
L4_PER2	L4_PER2_CLK	Int	133	L4PER2_L3_GICK	CORE_X2_CLK	DPLL_CORE
L4_PER3	L4_PER3_CLK	Int	133	L4PER3_L3_GICK	CORE_X2_CLK	DPLL_CORE
L4_WKUP	L4_WKUP_CLK	Int	38.4	WKUPAON_GICK	SYS_CLK1	OSC1
					DPLL_ABE_X2_CLK	DPLL_ABE
MAILBOX1	MAILBOX1_FLCK	Int	266	L4CFG_L3_GICK	CORE_X2_CLK	DPLL_CORE
MAILBOX2	MAILBOX2_FLCK	Int	266	L4CFG_L3_GICK	CORE_X2_CLK	DPLL_CORE
MAILBOX3	MAILBOX3_FLCK	Int	266	L4CFG_L3_GICK	CORE_X2_CLK	DPLL_CORE
MAILBOX4	MAILBOX4_FLCK	Int	266	L4CFG_L3_GICK	CORE_X2_CLK	DPLL_CORE
MAILBOX5	MAILBOX5_FLCK	Int	266	L4CFG_L3_GICK	CORE_X2_CLK	DPLL_CORE
MAILBOX6	MAILBOX6_FLCK	Int	266	L4CFG_L3_GICK	CORE_X2_CLK	DPLL_CORE
MAILBOX7	MAILBOX7_FLCK	Int	266	L4CFG_L3_GICK	CORE_X2_CLK	DPLL_CORE
MAILBOX8	MAILBOX8_FLCK	Int	266	L4CFG_L3_GICK	CORE_X2_CLK	DPLL_CORE
MAILBOX9	MAILBOX9_FLCK	Int	266	L4CFG_L3_GICK	CORE_X2_CLK	DPLL_CORE
MAILBOX10	MAILBOX10_FLCK	Int	266	L4CFG_L3_GICK	CORE_X2_CLK	DPLL_CORE
MAILBOX11	MAILBOX11_FLCK	Int	266	L4CFG_L3_GICK	CORE_X2_CLK	DPLL_CORE
MAILBOX12	MAILBOX12_FLCK	Int	266	L4CFG_L3_GICK	CORE_X2_CLK	DPLL_CORE
MAILBOX13	MAILBOX13_FLCK	Int	266	L4CFG_L3_GICK	CORE_X2_CLK	DPLL_CORE

表 5-9. Maximum Supported Frequency (continued)

Module				Clock Sources		
Instance Name	Input Clock Name	Clock Type	Max. Clock Allowed (MHz)	PRCM Clock Name	PLL / OSC / Source Clock Name	PLL / OSC / Source Name
McASP1	MCASP1_AHCLKR	Func	100	MCASP1_AHCLKR	DPLL_ABE_X2_CLK	DPLL_ABE
					SYS_CLK1	OSC1
					FUNC_96M_AON_CLK	DPLL_PER
					ATLCLK0	Module ATL
					ATLCLK1	Module ATL
					ATLCLK2	Module ATL
					ATLCLK3	Module ATL
					SYS_CLK2	OSC2
					XREF_CLK0	XREF_CLK0
					XREF_CLK1	XREF_CLK1
					XREF_CLK2	XREF_CLK2
					XREF_CLK3	XREF_CLK3
	MLB_CLK	Module MLB				
	MLBP_CLK	Module MLB				
	MCASP1_AHCLKX	Func	100	MCASP1_AHCLKX	DPLL_ABE_X2_CLK	DPLL_ABE
					SYS_CLK1	OSC1
					FUNC_96M_AON_CLK	DPLL_PER
					ATLCLK0	Module ATL
					ATLCLK1	Module ATL
					ATLCLK2	Module ATL
ATLCLK3					Module ATL	
SYS_CLK2					OSC2	
XREF_CLK0					XREF_CLK0	
XREF_CLK1					XREF_CLK1	
XREF_CLK2					XREF_CLK2	
XREF_CLK3					XREF_CLK3	
MLB_CLK	Module MLB					
MLBP_CLK	Module MLB					
MCASP1_FCLK	Func	192	MCASP1_AUX_GFCLK	PER_ABE_X1_GFCLK	DPLL_ABE	
				VIDEO1_CLK	DPLL_VIDEO1	
				VIDEO2_CLK	DPLL_VIDEO2	
				HDMI_CLK	DPLL_HDMI	
MCASP1_ICLK	Int	266	IPU_L3_GICLK	CORE_X2_CLK	DPLL_CORE	

表 5-9. Maximum Supported Frequency (continued)

Module				Clock Sources		
Instance Name	Input Clock Name	Clock Type	Max. Clock Allowed (MHz)	PRCM Clock Name	PLL / OSC / Source Clock Name	PLL / OSC / Source Name
McASP2	MCASP2_AHCLKR	Func	100	MCASP2_AHCLKR	DPLL_ABE_X2_CLK	DPLL_ABE
					SYS_CLK1	OSC1
					FUNC_96M_AON_CLK	DPLL_PER
					ATL_CLK3	Module ATL
					ATL_CLK2	Module ATL
					ATL_CLK1	Module ATL
					ATL_CLK0	Module ATL
					SYS_CLK2	OSC2
					XREF_CLK0	XREF_CLK0
					XREF_CLK1	XREF_CLK1
	XREF_CLK2	XREF_CLK2				
	XREF_CLK3	XREF_CLK3				
	MLB_CLK	Module MLB				
	MLBP_CLK	Module MLB				
	MCASP2_AHCLKX	Func	100	MCASP2_AHCLKX	DPLL_ABE_X2_CLK	DPLL_ABE
					SYS_CLK1	OSC1
					FUNC_96M_AON_CLK	DPLL_PER
					ATL_CLK3	Module ATL
					ATL_CLK2	Module ATL
					ATL_CLK1	Module ATL
ATL_CLK0					Module ATL	
SYS_CLK2					OSC2	
XREF_CLK0					XREF_CLK0	
XREF_CLK1					XREF_CLK1	
XREF_CLK2	XREF_CLK2					
XREF_CLK3	XREF_CLK3					
MLB_CLK	Module MLB					
MLBP_CLK	Module MLB					
MCASP2_FCLK	Func	192	MCASP2_AUX_GFCLK	PER_ABE_X1_GFCLK	DPLL_ABE	
				VIDEO1_CLK	DPLL_VIDEO1	
				VIDEO2_CLK	DPLL_VIDEO2	
				HDMI_CLK	DPLL_HDMI	
MCASP2_ICLK	Int	266	L4PER2_L3_GICLK	CORE_X2_CLK	DPLL_CORE	

表 5-9. Maximum Supported Frequency (continued)

Module				Clock Sources		
Instance Name	Input Clock Name	Clock Type	Max. Clock Allowed (MHz)	PRCM Clock Name	PLL / OSC / Source Clock Name	PLL / OSC / Source Name
McASP3	MCASP3_AHCLKX	Func	100	MCASP3_AHCLKX	DPLL_ABE_X2_CLK	DPLL_ABE
					SYS_CLK1	OSC1
					FUNC_96M_AON_CLK	DPLL_PER
					ATL_CLK3	Module ATL
					ATL_CLK2	Module ATL
					ATL_CLK1	Module ATL
					ATL_CLK0	Module ATL
					SYS_CLK2	OSC2
					XREF_CLK0	XREF_CLK0
					XREF_CLK1	XREF_CLK1
					XREF_CLK2	XREF_CLK2
					XREF_CLK3	XREF_CLK3
	MLB_CLK	Module MLB				
	MLBP_CLK	Module MLB				
	McASP3	MCASP3_FCLK	Func	192	MCASP3_AUX_GFCLK	PER_ABE_X1_GF_CLK
VIDEO1_CLK						DPLL_ABE
VIDEO2_CLK						DPLL_VIDEO2
HDMI_CLK						DPLL_HDMI
McASP3	MCASP3_ICLK	Int	266	L4PER2_L3_GICLK	CORE_X2_CLK	DPLL_CORE
McASP4	MCASP4_AHCLKX	Func	100	MCASP4_AHCLKX	DPLL_ABE_X2_CLK	DPLL_ABE
					SYS_CLK1	OSC1
					FUNC_96M_AON_CLK	DPLL_PER
					ATL_CLK3	Module ATL
					ATL_CLK2	Module ATL
					ATL_CLK1	Module ATL
					ATL_CLK0	Module ATL
					SYS_CLK2	OSC2
					XREF_CLK0	XREF_CLK0
					XREF_CLK1	XREF_CLK1
					XREF_CLK2	XREF_CLK2
					XREF_CLK3	XREF_CLK3
	MLB_CLK	Module MLB				
	MLBP_CLK	Module MLB				
	McASP4	MCASP4_FCLK	Func	192	MCASP4_AUX_GFCLK	PER_ABE_X1_GF_CLK
VIDEO1_CLK						DPLL_ABE
VIDEO2_CLK						DPLL_VIDEO2
HDMI_CLK						DPLL_HDMI
McASP4	MCASP4_ICLK	Int	266	L4PER2_L3_GICLK	CORE_X2_CLK	DPLL_CORE

表 5-9. Maximum Supported Frequency (continued)

Module				Clock Sources		
Instance Name	Input Clock Name	Clock Type	Max. Clock Allowed (MHz)	PRCM Clock Name	PLL / OSC / Source Clock Name	PLL / OSC / Source Name
McASP5	MCASP5_AHCLKX	Func	100	MCASP5_AHCLKX	DPLL_ABE_X2_CLK	DPLL_ABE
					SYS_CLK1	OSC1
					FUNC_96M_AON_CLK	DPLL_PER
					ATL_CLK3	Module ATL
					ATL_CLK2	Module ATL
					ATL_CLK1	Module ATL
					ATL_CLK0	Module ATL
					SYS_CLK2	OSC2
					XREF_CLK0	XREF_CLK0
					XREF_CLK1	XREF_CLK1
					XREF_CLK2	XREF_CLK2
					XREF_CLK3	XREF_CLK3
	MLB_CLK	Module MLB				
	MLBP_CLK	Module MLB				
	MCASP5_FCLK	Func	192	MCASP5_AUX_GFCLK	PER_ABE_X1_GFCLK	DPLL_ABE
VIDEO1_CLK					DPLL_ABE	
VIDEO2_CLK					DPLL_VIDEO2	
HDMI_CLK					DPLL_HDMI	
MCASP5_ICLK	Int	266	L4PER2_L3_GICLK	CORE_X2_CLK	DPLL_CORE	
McASP6	MCASP6_AHCLKX	Func	100	MCASP6_AHCLKX	DPLL_ABE_X2_CLK	DPLL_ABE
					FUNC_96M_AON_CLK	DPLL_PER
					ATL_CLK3	Module ATL
					ATL_CLK2	Module ATL
					ATL_CLK1	Module ATL
					ATL_CLK0	Module ATL
					MLB_CLK	Module MLB
					MLBP_CLK	Module MLB
					SYS_CLK1	OSC1
					SYS_CLK2	OSC2
					XREF_CLK0	XREF_CLK0
					XREF_CLK1	XREF_CLK1
	XREF_CLK2	XREF_CLK2				
	XREF_CLK3	XREF_CLK3				
	MCASP6_FCLK	Func	192	MCASP6_AUX_GFCLK	PER_ABE_X1_GFCLK	DPLL_ABE
VIDEO1_CLK					DPLL_ABE	
VIDEO2_CLK					DPLL_VIDEO2	
HDMI_CLK					DPLL_HDMI	
MCASP6_ICLK	Int	266	L4PER2_L3_GICLK	CORE_X2_CLK	DPLL_CORE	

表 5-9. Maximum Supported Frequency (continued)

Module				Clock Sources		
Instance Name	Input Clock Name	Clock Type	Max. Clock Allowed (MHz)	PRCM Clock Name	PLL / OSC / Source Clock Name	PLL / OSC / Source Name
McASP7	MCASP7_AHCLKX	Func	100	MCASP7_AHCLKX	DPLL_ABE_X2_CLK	DPLL_ABE
					SYS_CLK1	OSC1
					FUNC_96M_AON_CLK	DPLL_PER
					ATL_CLK3	Module ATL
					ATL_CLK2	Module ATL
					ATL_CLK1	Module ATL
					ATL_CLK0	Module ATL
					SYS_CLK2	OSC2
					XREF_CLK0	XREF_CLK0
					XREF_CLK1	XREF_CLK1
					XREF_CLK2	XREF_CLK2
					XREF_CLK3	XREF_CLK3
	MLB_CLK	Module MLB				
	MLBP_CLK	Module MLB				
	McASP7	MCASP7_FCLK	Func	192	MCASP7_AUX_GFCLK	PER_ABE_X1_GF_CLK
VIDEO1_CLK						DPLL_ABE
VIDEO2_CLK						DPLL_VIDEO2
HDMI_CLK						DPLL_HDMI
McASP7	MCASP7_ICLK	Int	266	L4PER2_L3_GICLK	CORE_X2_CLK	DPLL_CORE
McASP8	MCASP8_AHCLKX	Func	100	MCASP8_AHCLKX	DPLL_ABE_X2_CLK	DPLL_ABE
					SYS_CLK1	OSC1
					FUNC_96M_AON_CLK	DPLL_PER
					ATL_CLK3	Module ATL
					ATL_CLK2	Module ATL
					ATL_CLK1	Module ATL
					ATL_CLK0	Module ATL
					SYS_CLK2	OSC2
					XREF_CLK0	XREF_CLK0
					XREF_CLK1	XREF_CLK1
					XREF_CLK2	XREF_CLK2
					XREF_CLK3	XREF_CLK3
	MLB_CLK	Module MLB				
	MLBP_CLK	Module MLB				
	McASP8	MCASP8_FCLK	Func	192	MCASP8_AUX_GFCLK	PER_ABE_X1_GF_CLK
VIDEO1_CLK						DPLL_ABE
VIDEO2_CLK						DPLL_VIDEO2
HDMI_CLK						DPLL_HDMI
McASP8	MCASP8_ICLK	Int	266	L4PER2_L3_GICLK	CORE_X2_CLK	DPLL_CORE
McSPI1	SPI1_ICLK	Int	266	L4PER_L3_GICLK	CORE_X2_CLK	DPLL_CORE
	SPI1_FCLK	Func	48	PER_48M_GFCLK	PER_48M_GFCLK	DPLL_PER

表 5-9. Maximum Supported Frequency (continued)

Module				Clock Sources		
Instance Name	Input Clock Name	Clock Type	Max. Clock Allowed (MHz)	PRCM Clock Name	PLL / OSC / Source Clock Name	PLL / OSC / Source Name
McSPI2	SPI2_ICLK	Int	266	L4PER_L3_GICLK	CORE_X2_CLK	DPLL_CORE
	SPI2_FCLK	Func	48	PER_48M_GFCLK	PER_48M_GFCLK	DPLL_PER
McSPI3	SPI3_ICLK	Int	266	L4PER_L3_GICLK	CORE_X2_CLK	DPLL_CORE
	SPI3_FCLK	Func	48	PER_48M_GFCLK	PER_48M_GFCLK	DPLL_PER
McSPI4	SPI4_ICLK	Int	266	L4PER_L3_GICLK	CORE_X2_CLK	DPLL_CORE
	SPI4_FCLK	Func	48	PER_48M_GFCLK	PER_48M_GFCLK	DPLL_PER
MLB_SS	MLB_L3_ICLK	Int	266	MLB_SHB_L3_GICLK	CORE_X2_CLK	DPLL_CORE
	MLB_L4_ICLK	Int	133	MLB_SPB_L4_GICLK	CORE_X2_CLK	DPLL_CORE
	MLB_FCLK	Func	266	MLB_SYS_L3_GFCLK	CORE_X2_CLK	DPLL_CORE
MMC1	MMC1_CLK_32K	Func	0.032	L3INIT_32K_GFCLK	FUNC_32K_CLK	OSC1
	MMC1_FCLK	Func	192	MMC1_GFCLK	FUNC_192M_CLK	DPLL_PER
			128		FUNC_256M_CLK	DPLL_PER
	MMC1_ICLK1	Int	266	L3INIT_L3_GICLK	CORE_X2_CLK	DPLL_CORE
MMC1_ICLK2	Int	133	L3INIT_L4_GICLK	CORE_X2_CLK	DPLL_CORE	
MMC2	MMC2_CLK_32K	Func	0.032	L3INIT_32K_GFCLK	FUNC_32K_CLK	OSC1
	MMC2_FCLK	Func	192	MMC2_GFCLK	FUNC_192M_CLK	DPLL_PER
			128		FUNC_256M_CLK	DPLL_PER
	MMC2_ICLK1	Int	266	L3INIT_L3_GICLK	CORE_X2_CLK	DPLL_CORE
MMC2_ICLK2	Int	133	L3INIT_L4_GICLK	CORE_X2_CLK	DPLL_CORE	
MMC3	MMC3_ICLK	Int	266	L4PER_L3_GICLK	CORE_X2_CLK	DPLL_CORE
	MMC3_CLK_32K	Func	0.032	L4PER_32K_GFCLK	FUNC_32K_CLK	OSC1
	MMC3_FCLK	Func	48	MMC3_GFCLK	FUNC_192M_CLK	DPLL_PER
192						
MMC4	MMC4_ICLK	Int	266	L4PER_L3_GICLK	CORE_X2_CLK	DPLL_CORE
	MMC4_CLK_32K	Func	0.032	L4PER_32K_GFCLK	FUNC_32K_CLK	OSC1
	MMC4_FCLK	Func	48	MMC4_GFCLK	FUNC_192M_CLK	DPLL_PER
192						
MMU_EDMA	MMU1_CLK	Int	266	L3MAIN1_L3_GICLK	CORE_X2_CLK	DPLL_CORE
MMU_PCIESS	MMU2_CLK	Int	266	L3MAIN1_L3_GICLK	CORE_X2_CLK	DPLL_CORE
MPU	MPU_CLK	Int & Func	MPU_CLK	MPU_GCLK	MPU_GCLK	DPLL_MPU
MPU_EMU_DBG	FCLK	Int	38.4	EMU_SYS_CLK	SYS_CLK1	OSC1
					MPU_GCLK	DPLL_MPU
OCMC_RAM1	OCMC1_L3_CLK	Int	266	L3MAIN1_L3_GICLK	CORE_X2_CLK	DPLL_CORE
OCMC_RAM2	OCMC2_L3_CLK	Int	266	L3MAIN1_L3_GICLK	CORE_X2_CLK	DPLL_CORE
OCMC_RAM3	OCMC3_L3_CLK	Int	266	L3MAIN1_L3_GICLK	CORE_X2_CLK	DPLL_CORE
OCMC_ROM	OCMC_L3_CLK	Int	266	L3MAIN1_L3_GICLK	CORE_X2_CLK	DPLL_CORE
OCP_WP_NOC	PICLKOCPL3	Int	266	L3INSTR_L3_GICLK	CORE_X2_CLK	DPLL_CORE
OCP2SCP1	L4CFG1_ADAPTE R_CLKIN	Int	133	L3INIT_L4_GICLK	CORE_X2_CLK	DPLL_CORE
OCP2SCP2	L4CFG2_ADAPTE R_CLKIN	Int	133	L4CFG_L4_GICLK	CORE_X2_CLK	DPLL_CORE
OCP2SCP3	L4CFG3_ADAPTE R_CLKIN	Int	133	L3INIT_L4_GICLK	CORE_X2_CLK	DPLL_CORE

表 5-9. Maximum Supported Frequency (continued)

Module				Clock Sources		
Instance Name	Input Clock Name	Clock Type	Max. Clock Allowed (MHz)	PRCM Clock Name	PLL / OSC / Source Clock Name	PLL / OSC / Source Name
PCIESS1	PCIE1_PHY_WKU_P_CLK	Func	0.032	PCIE_32K_GFCLK	FUNC_32K_CLK	RTC Oscillator
	PCle_SS1_FICLK	Int	266	PCIE_L3_GICLK	CORE_X2_CLK	DPLL_CORE
	PCIEPHY_CLK	Func	2500	PCIE_PHY_GCLK	PCIE_PHY_GCLK	APLL_PCIE
	PCIEPHY_CLK_DIV	Func	1250	PCIE_PHY_DIV_GCLK	PCIE_PHY_DIV_GCLK	APLL_PCIE
	PCIE1_REF_CLKIN	Func	34.3	PCIE_REF_GFCLK	CORE_USB_OTG_SS_LFPS_TX_CLK	DPLL_CORE
	PCIE1_PWR_CLK	Func	38.4	PCIE_SYS_GFCLK	SYS_CLK1	OSC1
PCIESS2	PCIE2_PHY_WKU_P_CLK	Func	0.032	PCIE_32K_GFCLK	FUNC_32K_CLK	RTC Oscillator
	PCle_SS2_FICLK	Func	266	PCIE_L3_GICLK	CORE_X2_CLK	DPLL_CORE
	PCIEPHY_CLK	Func	2500	PCIE_PHY_GCLK	PCIE_PHY_GCLK	APLL_PCIE
	PCIEPHY_CLK_DIV	Func	1250	PCIE_PHY_DIV_GCLK	PCIE_PHY_DIV_GCLK	APLL_PCIE
	PCIE2_REF_CLKIN	Func	34.3	PCIE_REF_GFCLK	CORE_USB_OTG_SS_LFPS_TX_CLK	DPLL_CORE
	PCIE2_PWR_CLK	Func	38.4	PCIE_SYS_GFCLK	SYS_CLK1	OSC1
PRCM_MPU	32K_CLK	Func	0.032	FUNC_32K_CLK	SYS_CLK1/610	OSC1
	SYS_CLK	Func	38.4	WKUPAON_ICLK	SYS_CLK1	OSC1
					DPLL_ABE_X2_CLK	DPLL_ABE
PWMSS1	PWMSS1_GICLK	Int & Func	266	L4PER2_L3_GICLK	CORE_X2_CLK	DPLL_CORE
PWMSS2	PWMSS2_GICLK	Int & Func	266	L4PER2_L3_GICLK	CORE_X2_CLK	DPLL_CORE
PWMSS3	PWMSS3_GICLK	Int & Func	266	L4PER2_L3_GICLK	CORE_X2_CLK	DPLL_CORE
QSPI	QSPI_ICLK	Int	266	L4PER2_L3_GICLK	CORE_X2_CLK	DPLL_CORE
	QSPI_FCLK	Func	128	QSPI_GFCLK	FUNC_256M_CLK	DPLL_PER
					PER_QSPI_CLK	DPLL_PER
RNG	RNG_ICLK	Int	266	L4SEC_L3_GICLK	CORE_X2_CLK	DPLL_CORE
RTC_SS	RTC_ICLK	Int	133	RTC_L4_GICLK	CORE_X2_CLK	DPLL_CORE
	RTC_FCLK	Func	RTC_FCLK	RTC_AUX_CLK	FUNC_32K_CLK	RTC Oscillator
				FUNC_32K_CLK	SYS_CLK1/610	OSC1
SAR_ROM	PRCM_ROM_CLOCK	Int	266	L4CFG_L3_GICLK	CORE_X2_CLK	DPLL_CORE
SATA	SATA_FICLK	Int	266	L3INIT_L3_GICLK	CORE_X2_CLK	DPLL_CORE
	SATA_PMALIVE_FCLK	Func	48	L3INIT_48M_GFCLK	FUNC_192M_CLK	DPLL_PER
	REF_CLK	Func	38	SATA_REF_GFCLK	SYS_CLK1	OSC1
SDMA	SDMA_FCLK	Int & Func	266	DMA_L3_GICLK	CORE_X2_CLK	DPLL_CORE
SHA2MD51	SHAM_1_CLK	Int	266	L4SEC_L3_GICLK	CORE_X2_CLK	DPLL_CORE
SHA2MD52	SHAM_2_CLK	Int	266	L4SEC_L3_GICLK	CORE_X2_CLK	DPLL_CORE
SL2	IVA_GCLK	Int	IVA_GCLK	IVA_GCLK	IVA_GFCLK	DPLL_IVA

表 5-9. Maximum Supported Frequency (continued)

Module				Clock Sources		
Instance Name	Input Clock Name	Clock Type	Max. Clock Allowed (MHz)	PRCM Clock Name	PLL / OSC / Source Clock Name	PLL / OSC / Source Name
SMARTREFLEX_CORE	MCLK	Int	133	COREAON_L4_GICLK	CORE_X2_CLK	DPLL_CORE
	SYSCLK	Func	38.4	WKUPAON_ICLK	SYS_CLK1 DPLL_ABE_X2_CLK	OSC1 DPLL_ABE
SMARTREFLEX_DSPEVE	MCLK	Int	133	COREAON_L4_GICLK	CORE_X2_CLK	DPLL_CORE
	SYSCLK	Func	38.4	WKUPAON_ICLK	SYS_CLK1 DPLL_ABE_X2_CLK	OSC1 DPLL_ABE
SMARTREFLEX_GPU	MCLK	Int	133	COREAON_L4_GICLK	CORE_X2_CLK	DPLL_CORE
	SYSCLK	Func	38.4	WKUPAON_ICLK	SYS_CLK1 DPLL_ABE_X2_CLK	OSC1 DPLL_ABE
SMARTREFLEX_IVAHD	MCLK	Int	133	COREAON_L4_GICLK	CORE_X2_CLK	DPLL_CORE
	SYSCLK	Func	38.4	WKUPAON_ICLK	SYS_CLK1 DPLL_ABE_X2_CLK	OSC1 DPLL_ABE
SMARTREFLEX_MPU	MCLK	Int	133	COREAON_L4_GICLK	CORE_X2_CLK	DPLL_CORE
	SYSCLK	Func	38.4	WKUPAON_ICLK	SYS_CLK1 DPLL_ABE_X2_CLK	OSC1 DPLL_ABE
SPINLOCK	SPINLOCK_ICLK	Int	266	L4CFG_L3_GICLK	CORE_X2_CLK	DPLL_CORE
TIMER1	TIMER1_ICLK	Int	38.4	WKUPAON_GICLK	SYS_CLK1	OSC1
					DPLL_ABE_X2_CLK	DPLL_ABE
	TIMER1_FCLK	Func	100	TIMER1_GFCLK	SYS_CLK1	OSC1
					FUNC_32K_CLK	OSC1 RTC Oscillator
					SYS_CLK2	OSC2
					XREF_CLK0	XREF_CLK0
					XREF_CLK1	XREF_CLK1
					XREF_CLK2	XREF_CLK2
					XREF_CLK3	XREF_CLK3
					DPLL_ABE_X2_CLK	DPLL_ABE
					VIDEO1_CLK	DPLL_VIDEO1
VIDEO2_CLK	DPLL_VIDEO2					
HDMI_CLK	DPLL_HDMI					

表 5-9. Maximum Supported Frequency (continued)

Module				Clock Sources		
Instance Name	Input Clock Name	Clock Type	Max. Clock Allowed (MHz)	PRCM Clock Name	PLL / OSC / Source Clock Name	PLL / OSC / Source Name
TIMER2	TIMER2_ICLK	Int	266	L4PER_L3_GICLK	CORE_X2_CLK	DPLL_CORE
	TIMER2_FCLK	Func	100	TIMER2_GFCLK	SYS_CLK1	OSC1
					FUNC_32K_CLK	OSC1
						RTC Oscillator
					SYS_CLK2	OSC2
					XREF_CLK0	XREF_CLK0
					XREF_CLK1	XREF_CLK1
					XREF_CLK2	XREF_CLK2
					XREF_CLK3	XREF_CLK3
					DPLL_ABE_X2_CLK	DPLL_ABE
					VIDEO1_CLK	DPLL_VIDEO1
VIDEO2_CLK	DPLL_VIDEO2					
HDMI_CLK	DPLL_HDMI					
TIMER3	TIMER3_ICLK	Int	266	L4PER_L3_GICLK	CORE_X2_CLK	DPLL_CORE
	TIMER3_FCLK	Func	100	TIMER3_GFCLK	SYS_CLK1	OSC1
					FUNC_32K_CLK	OSC1
						RTC Oscillator
					SYS_CLK2	OSC2
					XREF_CLK0	XREF_CLK0
					XREF_CLK1	XREF_CLK1
					XREF_CLK2	XREF_CLK2
					XREF_CLK3	XREF_CLK3
					DPLL_ABE_X2_CLK	DPLL_ABE
					VIDEO1_CLK	DPLL_VIDEO1
VIDEO2_CLK	DPLL_VIDEO2					
HDMI_CLK	DPLL_HDMI					
TIMER4	TIMER4_ICLK	Int	266	L4PER_L3_GICLK	CORE_X2_CLK	DPLL_CORE
	TIMER4_FCLK	Func	100	TIMER4_GFCLK	SYS_CLK1	OSC1
					FUNC_32K_CLK	OSC1
						RTC Oscillator
					SYS_CLK2	OSC2
					XREF_CLK0	XREF_CLK0
					XREF_CLK1	XREF_CLK1
					XREF_CLK2	XREF_CLK2
					XREF_CLK3	XREF_CLK3
					DPLL_ABE_X2_CLK	DPLL_ABE
					VIDEO1_CLK	DPLL_VIDEO1
VIDEO2_CLK	DPLL_VIDEO2					
HDMI_CLK	DPLL_HDMI					

表 5-9. Maximum Supported Frequency (continued)

Module				Clock Sources		
Instance Name	Input Clock Name	Clock Type	Max. Clock Allowed (MHz)	PRCM Clock Name	PLL / OSC / Source Clock Name	PLL / OSC / Source Name
TIMER5	TIMER5_ICLK	Int	266	IPU_L3_GICLK	CORE_X2_CLK	DPLL_CORE
	TIMER5_FCLK	Func	100	TIMER5_GFCLK	SYS_CLK1	OSC1
					FUNC_32K_CLK	OSC1
						RTC Oscillator
					SYS_CLK2	OSC2
					XREF_CLK0	XREF_CLK0
					XREF_CLK1	XREF_CLK1
					XREF_CLK2	XREF_CLK2
					XREF_CLK3	XREF_CLK3
					DPLL_ABE_X2_CLK	DPLL_ABE
					VIDEO1_CLK	DPLL_VIDEO1
					VIDEO2_CLK	DPLL_VIDEO2
HDMI_CLK	DPLL_HDMI					
CLKOUTMUX[0]	CLKOUTMUX[0]					
TIMER6	TIMER6_ICLK	Int	266	IPU_L3_GICLK	CORE_X2_CLK	DPLL_CORE
	TIMER6_FCLK	Func	100	TIMER6_GFCLK	SYS_CLK1	OSC1
					FUNC_32K_CLK	OSC1
						RTC Oscillator
					SYS_CLK2	OSC2
					XREF_CLK0	XREF_CLK0
					XREF_CLK1	XREF_CLK1
					XREF_CLK2	XREF_CLK2
					XREF_CLK3	XREF_CLK3
					DPLL_ABE_X2_CLK	DPLL_ABE
					VIDEO1_CLK	DPLL_VIDEO1
					VIDEO2_CLK	DPLL_VIDEO2
HDMI_CLK	DPLL_HDMI					
CLKOUTMUX[0]	CLKOUTMUX[0]					
TIMER7	TIMER7_ICLK	Int	266	IPU_L3_GICLK	CORE_X2_CLK	DPLL_CORE
	TIMER7_FCLK	Func	100	TIMER7_GFCLK	SYS_CLK1	OSC1
					FUNC_32K_CLK	OSC1
						RTC Oscillator
					SYS_CLK2	OSC2
					XREF_CLK0	XREF_CLK0
					XREF_CLK1	XREF_CLK1
					XREF_CLK2	XREF_CLK2
					XREF_CLK3	XREF_CLK3
					DPLL_ABE_X2_CLK	DPLL_ABE
					VIDEO1_CLK	DPLL_VIDEO1
					VIDEO2_CLK	DPLL_VIDEO2
HDMI_CLK	DPLL_HDMI					
CLKOUTMUX[0]	CLKOUTMUX[0]					

表 5-9. Maximum Supported Frequency (continued)

Module				Clock Sources		
Instance Name	Input Clock Name	Clock Type	Max. Clock Allowed (MHz)	PRCM Clock Name	PLL / OSC / Source Clock Name	PLL / OSC / Source Name
TIMER8	TIMER8_ICLK	Int	266	IPU_L3_GICLK	CORE_X2_CLK	DPLL_CORE
	TIMER8_FCLK	Func	100	TIMER8_GFCLK	SYS_CLK1	OSC1
					FUNC_32K_CLK	OSC1
						RTC Oscillator
					SYS_CLK2	OSC2
					XREF_CLK0	XREF_CLK0
					XREF_CLK1	XREF_CLK1
					XREF_CLK2	XREF_CLK2
					XREF_CLK3	XREF_CLK3
					DPLL_ABE_X2_CLK	DPLL_ABE
					VIDEO1_CLK	DPLL_VIDEO1
					VIDEO2_CLK	DPLL_VIDEO2
HDMI_CLK	DPLL_HDMI					
CLKOUTMUX[0]	CLKOUTMUX[0]					
TIMER9	TIMER9_ICLK	Int	266	L4PER_L3_GICLK	CORE_X2_CLK	DPLL_CORE
	TIMER9_FCLK	Func	100	TIMER9_GFCLK	SYS_CLK1	OSC1
					FUNC_32K_CLK	OSC1
						RTC Oscillator
					SYS_CLK2	OSC2
					XREF_CLK0	XREF_CLK0
					XREF_CLK1	XREF_CLK1
					XREF_CLK2	XREF_CLK2
					XREF_CLK3	XREF_CLK3
					DPLL_ABE_X2_CLK	DPLL_ABE
					VIDEO1_CLK	DPLL_VIDEO1
					VIDEO2_CLK	DPLL_VIDEO2
HDMI_CLK	DPLL_HDMI					
TIMER10	TIMER10_ICLK	Int	266	L4PER_L3_GICLK	CORE_X2_CLK	DPLL_CORE
	TIMER10_FCLK	Func	100	TIMER10_GFCLK	SYS_CLK1	OSC1
					FUNC_32K_CLK	OSC1
						RTC Oscillator
					SYS_CLK2	OSC2
					XREF_CLK0	XREF_CLK0
					XREF_CLK1	XREF_CLK1
					XREF_CLK2	XREF_CLK2
					XREF_CLK3	XREF_CLK3
					DPLL_ABE_X2_CLK	DPLL_ABE
					VIDEO1_CLK	DPLL_VIDEO1
					VIDEO2_CLK	DPLL_VIDEO2
HDMI_CLK	DPLL_HDMI					

表 5-9. Maximum Supported Frequency (continued)

Module				Clock Sources		
Instance Name	Input Clock Name	Clock Type	Max. Clock Allowed (MHz)	PRCM Clock Name	PLL / OSC / Source Clock Name	PLL / OSC / Source Name
TIMER11	TIMER11_ICLK	Int	266	L4PER_L3_GICLK	CORE_X2_CLK	DPLL_CORE
	TIMER11_FCLK	Func	100	TIMER11_GFCLK	SYS_CLK1	OSC1
					FUNC_32K_CLK	OSC1
						RTC Oscillator
					SYS_CLK2	OSC2
					XREF_CLK0	XREF_CLK0
					XREF_CLK1	XREF_CLK1
					XREF_CLK2	XREF_CLK2
					XREF_CLK3	XREF_CLK3
					DPLL_ABE_X2_CLK	DPLL_ABE
					VIDEO1_CLK	DPLL_VIDEO1
VIDEO2_CLK	DPLL_VIDEO2					
HDMI_CLK	DPLL_HDMI					
TIMER12	TIMER12_ICLK	Int	38.4	WKUPAON_GICLK	SYS_CLK1	OSC1
	TIMER12_FCLK	Func	0.032	OSC_32K_CLK	DPLL_ABE_X2_CLK	DPLL_ABE
					RC_CLK	RC oscillator
TIMER13	TIMER13_ICLK	Int	266	L4PER3_L3_GICLK	CORE_X2_CLK	DPLL_CORE
	TIMER13_FCLK	Func	100	TIMER13_GFCLK	SYS_CLK1	OSC1
					FUNC_32K_CLK	OSC1
						RTC Oscillator
					SYS_CLK2	OSC2
					XREF_CLK0	XREF_CLK0
					XREF_CLK1	XREF_CLK1
					XREF_CLK2	XREF_CLK2
					XREF_CLK3	XREF_CLK3
					DPLL_ABE_X2_CLK	DPLL_ABE
					VIDEO1_CLK	DPLL_VIDEO1
VIDEO2_CLK	DPLL_VIDEO2					
HDMI_CLK	DPLL_HDMI					
TIMER14	TIMER14_ICLK	Int	266	L4PER3_L3_GICLK	CORE_X2_CLK	DPLL_CORE
	TIMER14_FCLK	Func	100	TIMER14_GFCLK	SYS_CLK1	OSC1
					FUNC_32K_CLK	OSC1
						RTC Oscillator
					SYS_CLK2	OSC2
					XREF_CLK0	XREF_CLK0
					XREF_CLK1	XREF_CLK1
					XREF_CLK2	XREF_CLK2
					XREF_CLK3	XREF_CLK3
					DPLL_ABE_X2_CLK	DPLL_ABE
					VIDEO1_CLK	DPLL_VIDEO1
VIDEO2_CLK	DPLL_VIDEO2					
HDMI_CLK	DPLL_HDMI					

表 5-9. Maximum Supported Frequency (continued)

Module				Clock Sources		
Instance Name	Input Clock Name	Clock Type	Max. Clock Allowed (MHz)	PRCM Clock Name	PLL / OSC / Source Clock Name	PLL / OSC / Source Name
TIMER15	TIMER15_ICLK	Int	266	L4PER3_L3_GICLK	CORE_X2_CLK	DPLL_CORE
	TIMER15_FCLK	Func	100	TIMER15_GFCLK	SYS_CLK1	OSC1
					FUNC_32K_CLK	OSC1
						RTC Oscillator
					SYS_CLK2	OSC2
					XREF_CLK0	XREF_CLK0
					XREF_CLK1	XREF_CLK1
					XREF_CLK2	XREF_CLK2
					XREF_CLK3	XREF_CLK3
					DPLL_ABE_X2_CLK	DPLL_ABE
					VIDEO1_CLK	DPLL_VIDEO1
VIDEO2_CLK	DPLL_VIDEO2					
HDMI_CLK	DPLL_HDMI					
TIMER16	TIMER16_ICLK	Int	266	L4PER3_L3_GICLK	CORE_X2_CLK	DPLL_CORE
	TIMER16_FCLK	Func	100	TIMER16_GFCLK	SYS_CLK1	OSC1
					FUNC_32K_CLK	OSC1
						RTC Oscillator
					SYS_CLK2	OSC2
					XREF_CLK0	XREF_CLK0
					XREF_CLK1	XREF_CLK1
					XREF_CLK2	XREF_CLK2
					XREF_CLK3	XREF_CLK3
					DPLL_ABE_X2_CLK	DPLL_ABE
					VIDEO1_CLK	DPLL_VIDEO1
VIDEO2_CLK	DPLL_VIDEO2					
HDMI_CLK	DPLL_HDMI					
TPCC	TPCC_GCLK	Int	266	L3MAIN1_L3_GICLK	CORE_X2_CLK	DPLL_CORE
TPTC1	TPTC0_GCLK	Int	266	L3MAIN1_L3_GICLK	CORE_X2_CLK	DPLL_CORE
TPTC2	TPTC1_GCLK	Int	266	L3MAIN1_L3_GICLK	CORE_X2_CLK	DPLL_CORE
UART1	UART1_FCLK	Func	48	UART1_GFCLK	FUNC_192M_CLK	DPLL_PER
	UART1_ICLK	Int	266	L4PER_L3_GICLK	CORE_X2_CLK	DPLL_CORE
UART2	UART2_FCLK	Func	48	UART2_GFCLK	FUNC_192M_CLK	DPLL_PER
	UART2_ICLK	Int	266	L4PER_L3_GICLK	CORE_X2_CLK	DPLL_CORE
UART3	UART3_FCLK	Func	48	UART3_GFCLK	FUNC_192M_CLK	DPLL_PER
	UART3_ICLK	Int	266	L4PER_L3_GICLK	CORE_X2_CLK	DPLL_CORE
UART4	UART4_FCLK	Func	48	UART4_GFCLK	FUNC_192M_CLK	DPLL_PER
	UART4_ICLK	Int	266	L4PER_L3_GICLK	CORE_X2_CLK	DPLL_CORE
UART5	UART5_FCLK	Func	48	UART5_GFCLK	FUNC_192M_CLK	DPLL_PER
	UART5_ICLK	Int	266	L4PER_L3_GICLK	CORE_X2_CLK	DPLL_CORE
UART6	UART6_FCLK	Func	48	UART6_GFCLK	FUNC_192M_CLK	DPLL_PER
	UART6_ICLK	Int	266	IPU_L3_GICLK	CORE_X2_CLK	DPLL_CORE
UART7	UART7_FCLK	Func	48	UART7_GFCLK	FUNC_192M_CLK	DPLL_PER
	UART7_ICLK	Int	266	L4PER2_L3_GICLK	CORE_X2_CLK	DPLL_CORE

表 5-9. Maximum Supported Frequency (continued)

Module				Clock Sources		
Instance Name	Input Clock Name	Clock Type	Max. Clock Allowed (MHz)	PRCM Clock Name	PLL / OSC / Source Clock Name	PLL / OSC / Source Name
UART8	UART8_FCLK	Func	48	UART8_GFCLK	FUNC_192M_CLK	DPLL_PER
	UART8_ICLK	Int	266	L4PER2_L3_GICLK	CORE_X2_CLK	DPLL_CORE
UART9	UART9_FCLK	Func	48	UART9_GFCLK	FUNC_192M_CLK	DPLL_PER
	UART9_ICLK	Int	266	L4PER2_L3_GICLK	CORE_X2_CLK	DPLL_CORE
UART10	UART10_FCLK	Func	48	UART10_GFCLK	FUNC_192M_CLK	DPLL_PER
	UART10_ICLK	Int	38.4	WKUPAON_GICLK	SYS_CLK1	OSC1
					DPLL_ABE_X2_CLK	DPLL_ABE
USB1	USB1_MICLK	Int	266	L3INIT_L3_GICLK	CORE_X2_CLK	DPLL_CORE
	USB3PHY_REF_CLK	Func	34.3	USB_LFPS_TX_GFCLK	CORE_USB_OTG_SS_LFPS_TX_CLK	DPLL_CORE
	USB2PHY1_TREF_CLK	Func	38.4	USB_OTG_SS_REF_CLK	SYS_CLK1	OSC1
	USB2PHY1_REF_CLK	Func	960	L3INIT_960M_GFCLK	L3INIT_960_GFCLK	DPLL_USB
USB2	USB2_MICLK	Int	266	L3INIT_L3_GICLK	CORE_X2_CLK	DPLL_CORE
	USB2PHY2_TREF_CLK	Func	38.4	USB_OTG_SS_REF_CLK	SYS_CLK1	OSC1
	USB2PHY2_REF_CLK	Func	960	L3INIT_960M_GFCLK	L3INIT_960_GFCLK	DPLL_USB
USB3	USB3_MICLK	Int	266	L3INIT_L3_GICLK	CORE_X2_CLK	DPLL_CORE
	USB3PHY_PWRS_CLK	Func	38.4	USB_OTG_SS_REF_CLK	SYS_CLK1	OSC1
USB4	USB4_MICLK	Int	266	L3INIT_L3_GICLK	CORE_X2_CLK	DPLL_CORE
	DPLL_USBSS_REF_CLK	Func	38.4	USB_OTG_SS_REF_CLK	SYS_CLK1	OSC1
USB_PHY1_CORE	USB2PHY1_WKUP_CLK	Func	0.032	COREAON_32K_GFCLK	SYS_CLK1/610	OSC1
USB_PHY2_CORE	USB2PHY2_WKUP_CLK	Func	0.032	COREAON_32K_GFCLK	SYS_CLK1/610	OSC1
USB_PHY3_CORE	USB3PHY_WKUP_CLK	Func	0.032	COREAON_32K_GFCLK	SYS_CLK1/610	OSC1
VCP1	VCP1_CLK	Int	266	L3MAIN1_L3_GICLK	CORE_X2_CLK	DPLL_CORE
VCP2	VCP2_CLK	Int	266	L3MAIN1_L3_GICLK	CORE_X2_CLK	DPLL_CORE
VIP1	L3_CLK_PROC_CLK	Int & Func	266	VIP1_GCLK	CORE_X2_CLK	DPLL_CORE
					CORE_ISS_MAIN_CLK	DPLL_CORE
VIP2	L3_CLK_PROC_CLK	Int & Func	266	VIP2_GCLK	CORE_X2_CLK	DPLL_CORE
					CORE_ISS_MAIN_CLK	DPLL_CORE
VIP3	L3_CLK_PROC_CLK	Int & Func	266	VIP3_GCLK	CORE_X2_CLK	DPLL_CORE
					CORE_ISS_MAIN_CLK	DPLL_CORE
VPE	L3_CLK_PROC_CLK	Int & Func	300	VPE_GCLK	CORE_ISS_MAIN_CLK	DPLL_CORE
					VIDEO1_CLKOUT4	DPLL_VIDEO1
WD_TIMER1	PIOCPCLK	Int	38.4	WKUPAON_GICLK	SYS_CLK1	OSC1
					DPLL_ABE_X2_CLK	DPLL_ABE
	PITIMERCLK	Func	0.032	OSC_32K_CLK	RC_CLK	RC oscillator

表 5-9. Maximum Supported Frequency (continued)

Module				Clock Sources		
Instance Name	Input Clock Name	Clock Type	Max. Clock Allowed (MHz)	PRCM Clock Name	PLL / OSC / Source Clock Name	PLL / OSC / Source Name
WD_TIMER2	WD_TIMER2_ICLK	Int	38.4	WKUPAON_GICLK	SYS_CLK1	OSC1
					DPLL_ABE_X2_CLK	DPLL_ABE
	WD_TIMER2_FCLK	Func	0.032	WKUPAON_SYS_GFC_LK	WKUPAON_32K_G_FCLK	RTC Oscillator

5.6 Power Consumption Summary

注: Maximum power consumption for this SoC depends on the specific use conditions for the end system. Contact your TI representative for assistance in estimating maximum power consumption for the end system use case.

5.7 Electrical Characteristics

注: The data specified in 5.7.1 through 5.7.14 are subject to change.

注: The interfaces or signals described in 5.7.1 through 5.7.14 correspond to the interfaces or signals available in multiplexing mode 0 (Function 1).

All interfaces or signals multiplexed on the balls described in these tables have the same DC electrical characteristics, unless multiplexing involves a PHY/GPIO combination in which case different DC electrical characteristics are specified for the different multiplexing modes (Functions).

5.7.1 LVCMOS DDR DC Electrical Characteristics

表 5-10 summarizes the DC electrical characteristics for LVCMOS DDR Buffers.

注: For more information on the I/O cell configurations (i[2:0], sr[1:0]), see the Chapter *Control Module* of the Device TRM.

表 5-10. LVCMOS DDR DC Electrical Characteristics

PARAMETER		MIN	NOM	MAX	UNIT
Signal Names in MUXMODE 0 (Single-Ended Signals): ddr1_d[31:0], ddr1_a[15:0], ddr1_dqm[3:0], ddr1_ba[2:0], ddr1_csn[0], ddr1_cke, ddr1_odt[0], ddr1_casn, ddr1_rasn, ddr1_wen, ddr1_rst, ddr1_ecc_d[7:0], ddr1_dqm_ecc, ddr2_d[31:0], ddr2_a[15:0], ddr2_dqm[3:0], ddr2_ba[2:0], ddr2_csn[0], ddr2_cke, ddr2_odt[0], ddr2_casn, ddr2_rasn, ddr2_wen, ddr2_rst;					
Balls: AA28 / AA25 / AA26 / Y24 / AA24 / Y23 / Y22 / AA23 / Y20 / AB27 / Y19 / AC27 / AC28 / AB28 / W20 / V20 / AD25 / AC24 / AC25 / AE26 / AF28 / AG27 / AF27 / AC23 / AE23 / AF23 / AE24 / AF24 / AH26 / AG26 / AF26 / AF25 / AD18 / AE17 / AF18 / AC21 / AD22 / AD21 / AE22 / AF22 / AE21 / AE21 / AH22 / AF21 / AB19 / AC20 / AC19 / AD20 / AA27 / AC26 / AB23 / AD23 / AB18 / AE18 / AF17 / AH23 / AG22 / AE20 / AC18 / AF20 / AH21 / AG21 / Y26 / V25 / V24 / Y25 / W23 / W19 / V23 / W22 / V26 / M26 / M25 / M24 / M23 / L28 / L25 / L26 / L27 / J20 / K22 / J23 / L24 / L23 / K21 / K20 / L22 / J24 / J26 / J25 / G26 / H26 / H24 / H25 / H23 / E28 / E27 / F27 / F26 / F24 / F25 / G25 / E26 / U22 / R22 / T22 / N28 / P26 / N23 / N27 / P27 / N20 / P25 / P22 / P23 / R27 / R28 / R26 / R25 / M22 / K23 / G24 / F28 / U26 / U27 / U23 / P24 / U24 / R23 / U28 / T23 / U25 / R24;					
Driver Mode					
V _{OH}	High-level output threshold (I _{OH} = 0.1 mA)	0.9*V _{DD} S			V
V _{OL}	Low-level output threshold (I _{OL} = 0.1 mA)			0.1*V _{DD} S	V
C _{PAD}	Pad capacitance (including package capacitance)			3	pF
Z _O	Output impedance (drive strength)	I[2:0] = 000 (Imp80)	80		Ω
		I[2:0] = 001 (Imp60)	60		
		I[2:0] = 010 (Imp48)	48		
		I[2:0] = 011 (Imp40)	40		
		I[2:0] = 100 (Imp34)	34		
Single-Ended Receiver Mode					
V _{IH}	High-level input threshold	DDR3/DDR3L	VREF+0.1	V _{DD} S+0.2	V
		DDR2	VREF+0.125	V _{DD} S+0.3	
V _{IL}	Low-level input threshold	DDR3/DDR3L	-0.2	VREF-0.1	V
		DDR2	-0.3	VREF-0.125	
V _{CM}	Input common-mode voltage	VREF -10%v _{dds}		VREF+ 10%v _{dds}	V
C _{PAD}	Pad capacitance (including package capacitance)			3	pF
Signal Names in MUXMODE 0 (Differential Signals): ddr1_dqs[3:0], ddr1_dqsn[3:0], ddr1_ck, ddr1_nck, ddr2_dqs[3:0], ddr2_dqsn[3:0], ddr2_ck, ddr2_nck, ddr1_dqs_ecc, ddr1_dqsn_ecc					
Bottom Balls: Y28 / AD27 / AE27 / AH25 / Y27 / AD28 / AE28 / AG25 / AG24 / AH24 / M28 / K27 / H27 / G28 / M27 / K28 / H28 / G27 / T28 / T27 / V27 / V28					
Driver Mode					
V _{OH}	High-level output threshold (I _{OH} = 0.1 mA)	0.9*V _{DD} S			V
V _{OL}	Low-level output threshold (I _{OL} = 0.1 mA)			0.1*V _{DD} S	V
C _{PAD}	Pad capacitance (including package capacitance)			3	pF
Z _O	Output impedance (drive strength)	I[2:0] = 000 (Imp80)	80		Ω
		I[2:0] = 001 (Imp60)	60		
		I[2:0] = 010 (Imp48)	48		
		I[2:0] = 011 (Imp40)	40		
		I[2:0] = 100 (Imp34)	34		
Single-Ended Receiver Mode					
V _{IH}	High-level input threshold	DDR3/DDR3L	VREF+0.1	V _{DD} S+0.2	V
		DDR2	VREF+0.125	V _{DD} S+0.3	

表 5-10. LVCMOS DDR DC Electrical Characteristics (continued)

PARAMETER		MIN	NOM	MAX	UNIT
V _{IL}	Low-level input threshold	DDR3/DDR3L	-0.2	VREF-0.1	V
		DDR2	-0.3	VREF-0.125	
V _{CM}	Input common-mode voltage	VREF -10%vdds		VREF+ 10%vdds	V
C _{PAD}	Pad capacitance (including package capacitance)			3	pF
Differential Receiver Mode					
V _{SWING}	Input voltage swing	DDR3/DDR3L	0.2	vdds+0.4	V
		DDR2	0.25	vdds+0.6	
V _{CM}	Input common-mode voltage	VREF -10%vdds		VREF+ 10%vdds	
C _{PAD}	Pad capacitance (including package capacitance)			3	pF

(1) VDDS stands for corresponding power supply (that is vdds_dds1 or vdds_dds2). For more information on the power supply name and the corresponding ball, see 表 4-2, POWER [11] column.

(2) VREF in this table stands for corresponding Reference Power Supply (that is ddr1_vref0 or ddr2_vref0). For more information on the power supply name and the corresponding ball, see 表 4-2, POWER [11] column.

5.7.2 HDMIPHY DC Electrical Characteristics

The HDMIPHY DC Electrical Characteristics are compliant with the HDMI 1.4a specification and are not reproduced here.

5.7.3 Dual Voltage LVCMOS I2C DC Electrical Characteristics

表 5-11 summarizes the DC electrical characteristics for Dual Voltage LVCMOS I2C Buffers.

注: For more information on the I/O cell configurations, see the Control Module section of the Device TRM.

表 5-11. Dual Voltage LVCMOS I2C DC Electrical Characteristics

PARAMETER	MIN	NOM	MAX	UNIT
Signal Names in MUXMODE 0: i2c2_scl; i2c1_scl; i2c1_sda; i2c2_sda;				
Balls: F17 / C20 / C21 / C25				
I²C Standard Mode – 1.8 V				
V _{IH}	Input high-level threshold	0.7*VDD5		V
V _{IL}	Input low-level threshold		0.3*VDD5	V
V _{hys}	Hysteresis	0.1*VDD5		V
I _{IN}	Input current at each I/O pin with an input voltage between 0.1*VDD5 to 0.9*VDD5		12	μA
I _{OZ}	I _{OZ} (I _{PAD} Current) for BIDI cell. This current is contributed by the tristated driver leakage + input current of the Rx + weak pullup/pulldown leakage. PAD is swept from 0 to VDD5 and the Max(I _{PAD}) is measured and is reported as I _{OZ}		12	μA
C _{IN}	Input capacitance		10	pF
V _{OL3}	Output low-level threshold open-drain at 3-mA sink current		0.2*VDD5	V
I _{OLmin}	Low-level output current @V _{OL} =0.2*VDD5	3		mA
t _{OF}	Output fall time from VIHmin to VILmax with a bus capacitance CB from 5 pF to 400 pF		250	ns
I²C Fast Mode – 1.8 V				
V _{IH}	Input high-level threshold	0.7*VDD5		V
V _{IL}	Input low-level threshold		0.3*VDD5	V

表 5-11. Dual Voltage LVC MOS I2C DC Electrical Characteristics (continued)

PARAMETER		MIN	NOM	MAX	UNIT
V _{hys}	Hysteresis	0.1*V _{DD5}			V
I _{IN}	Input current at each I/O pin with an input voltage between 0.1*V _{DD5} to 0.9*V _{DD5}			12	μA
I _{OZ}	I _{OZ} (I _{PAD} Current) for BIDI cell. This current is contributed by the tristated driver leakage + input current of the Rx + weak pullup/pulldown leakage. PAD is swept from 0 to V _{DD5} and the Max(I _{PAD}) is measured and is reported as I _{OZ}			12	μA
C _{IN}	Input capacitance			10	pF
V _{OL3}	Output low-level threshold open-drain at 3-mA sink current			0.2*V _{DD5}	V
I _{OLmin}	Low-level output current @V _{OL} =0.2*V _{DD5}	3			mA
t _{OF}	Output fall time from V _{IHmin} to V _{ILmax} with a bus capacitance CB from 10 pF to 400 pF	20+0.1*Cb		250	ns
I²C Standard Mode – 3.3 V					
V _{IH}	Input high-level threshold	0.7*V _{DD5}			V
V _{IL}	Input low-level threshold			0.3*V _{DD5}	V
V _{hys}	Hysteresis	0.05*V _{DD5}			V
I _{IN}	Input current at each I/O pin with an input voltage between 0.1*V _{DD5} to 0.9*V _{DD5}	31		80	μA
I _{OZ}	I _{OZ} (I _{PAD} Current) for BIDI cell. This current is contributed by the tristated driver leakage + input current of the Rx + weak pullup/pulldown leakage. PAD is swept from 0 to V _{DD5} and the Max(I _{PAD}) is measured and is reported as I _{OZ}	31		80	μA
C _{IN}	Input capacitance			10	pF
V _{OL3}	Output low-level threshold open-drain at 3-mA sink current			0.4	V
I _{OLmin}	Low-level output current @V _{OL} =0.4V	3			mA
I _{OLmin}	Low-level output current @V _{OL} =0.6V for full drive load (400pF/400KHz)	6			mA
t _{OF}	Output fall time from V _{IHmin} to V _{ILmax} with a bus capacitance CB from 5 pF to 400 pF			250	ns
I²C Fast Mode – 3.3 V					
V _{IH}	Input high-level threshold	0.7*V _{DD5}			V
V _{IL}	Input low-level threshold			0.3*V _{DD5}	V
V _{hys}	Hysteresis	0.05*V _{DD5}			V
I _{IN}	Input current at each I/O pin with an input voltage between 0.1*V _{DD5} to 0.9*V _{DD5}	31		80	μA
I _{OZ}	I _{OZ} (I _{PAD} Current) for BIDI cell. This current is contributed by the tristated driver leakage + input current of the Rx + weak pullup/pulldown leakage. PAD is swept from 0 to V _{DD5} and the Max(I _{PAD}) is measured and is reported as I _{OZ}	31		80	μA
C _{IN}	Input capacitance			10	pF
V _{OL3}	Output low-level threshold open-drain at 3-mA sink current			0.4	V
I _{OLmin}	Low-level output current @V _{OL} =0.4V	3			mA
I _{OLmin}	Low-level output current @V _{OL} =0.6V for full drive load (400pF/400KHz)	6			mA

表 5-11. Dual Voltage LVCMOS I2C DC Electrical Characteristics (continued)

PARAMETER		MIN	NOM	MAX	UNIT
t _{OF}	Output fall time from V _{IHmin} to V _{ILmax} with a bus capacitance CB from 10 pF to 200 pF (Proper External Resistor Value should be used as per I2C spec)	20+0.1*Cb		250	ns
	Output fall time from V _{IHmin} to V _{ILmax} with a bus capacitance CB from 300 pF to 400 pF (Proper External Resistor Value should be used as per I2C spec)	40		290	

(1) VDDS stands for corresponding power supply (that is vddshv3). For more information on the power supply name and the corresponding ball, see 表 4-2, POWER [11] column.

5.7.4 IQ1833 Buffers DC Electrical Characteristics

表 5-12 summarizes the DC electrical characteristics for IQ1833 Buffers.

表 5-12. IQ1833 Buffers DC Electrical Characteristics

PARAMETER		MIN	NOM	MAX	UNIT
Signal Names in MUXMODE 0: tclk;					
Balls: E20;					
1.8-V Mode					
V _{IH}	Input high-level threshold (Does not meet JEDEC V _{IH})	0.75 * VDDS			V
V _{IL}	Input low-level threshold (Does not meet JEDEC V _{IL})			0.25 * VDDS	V
V _{HYS}	Input hysteresis voltage	100			mV
I _{IN}	Input current at each I/O pin	2		11	μA
C _{PAD}	Pad capacitance (including package capacitance)			1	pF
3.3-V Mode					
V _{IH}	Input high-level threshold (Does not meet JEDEC V _{IH})	2.0			V
V _{IL}	Input low-level threshold (Does not meet JEDEC V _{IL})			0.6	V
V _{HYS}	Input hysteresis voltage	400			mV
I _{IN}	Input current at each I/O pin	5		11	μA
C _{PAD}	Pad capacitance (including package capacitance)			1	pF

(1) VDDS stands for corresponding power supply (that is vddshv3). For more information on the power supply name and the corresponding ball, see 表 4-2, POWER [11] column.

5.7.5 IHHV1833 Buffers DC Electrical Characteristics

表 5-13 summarizes the DC electrical characteristics for IHHV1833 Buffers.

表 5-13. IHHV1833 Buffers DC Electrical Characteristics

PARAMETER		MIN	NOM	MAX	UNIT
Signal Names in MUXMODE 0: porz / rtc_iso / rtc_porz / wakeup [3:0];					
Balls: F22 / AF14 / AB17 / AD17 / AC17 / AB16 / AC16;					
1.8-V Mode					
V _{IH}	Input high-level threshold	1.2			V
V _{IL}	Input low-level threshold			0.4	V
V _{HYS}	Input hysteresis voltage	40			mV
I _{IN}	Input current at each I/O pin	0.02		1	μA
C _{PAD}	Pad capacitance (including package capacitance)			1	pF

表 5-13. IHHV1833 Buffers DC Electrical Characteristics (continued)

PARAMETER		MIN	NOM	MAX	UNIT
3.3-V Mode					
V_{IH}	Input high-level threshold	1.2			V
V_{IL}	Input low-level threshold			0.4	V
V_{HYS}	Input hysteresis voltage	40			mV
I_{IN}	Input current at each I/O pin	5		8	μ A
C_{PAD}	Pad capacitance (including package capacitance)			1	pF

5.7.6 LVC MOS OSC Buffers DC Electrical Characteristics

表 5-14 summarizes the DC electrical characteristics for LVC MOS OSC Buffers.

表 5-14. LVC MOS OSC Buffers DC Electrical Characteristics

PARAMETER		MIN	NOM	MAX	UNIT
Signal Names in MUXMODE 0: rtc_osc_xi_clkln32 / rtc_osc_xo;					
Balls: AE14 / AD14;					
1.8-V Mode					
V_{IH}	Input high-level threshold	0.65 * VDD5			V
V_{IL}	Input low-level threshold			0.35 * VDD5	V
V_{HYS}	Input hysteresis voltage	150			mV
C_{PAD}	Pad capacitance (including package capacitance)			3	pF

(1) VDD5 stands for corresponding power supply (that is vdda_rtc). For more information on the power supply name and the corresponding ball, see 表 4-2, POWER [11] column.

5.7.7 ILVDS18 Buffers DC Electrical Characteristics

表 5-15 summarizes the DC electrical characteristics for ILVDS18 Buffers.

表 5-15. ILVDS18 Buffers DC Electrical Characteristics

PARAMETER		MIN	NOM	MAX	UNIT
Signal Names in MUXMODE 0: mlbp_clk_n / mlbp_clk_p;					
Balls: AB2 / AB1;					
1.8-V Mode					
V_{IN} (DC) single ended input voltage	Input voltage	0.5		VDD5- VSWING	
V_{IH}/V_{IL} (DC)	Input high-level threshold	$V_{CM} \pm$ 50mV			V
V_{HYS}	Input hysteresis voltage		NONE		mV
C_{PAD}	Pad capacitance (including package capacitance)			4	pF

(1) VDD5 stands for corresponding power supply (that is vdds_mlbp). For more information on the power supply name and the corresponding ball, see 表 4-2, POWER [11] column.

5.7.8 BMLB18 Buffers DC Electrical Characteristics

表 5-16 summarizes the DC electrical characteristics for BMLB18 Buffers.

表 5-16. BMLB18 Buffers DC Electrical Characteristics

PARAMETER		MIN	NOM	MAX	UNIT
Signal Names in MUXMODE 0: mlbp_dat_n / mlbp_dat_p / mlbp_sig_n / mlbp_sig_p;					
Balls: AA2 / AA1 / AC2 / AC1;					
1.8-V Mode					
V_{IH}/V_{IL}	Input high-level threshold	$V_{CM} \pm 50mV$			V
V_{HYS}	Input hysteresis voltage		NONE		mV
V_{OD}	Differential output voltage (measured with 50ohm resistor between PAD and PADN)	300		500	mV
V_{CM}	Common mode output voltage	1		1.5	V
C_{PAD}	Pad capacitance (including package capacitance)			4	pF

(1) VDDS stands for corresponding power supply (that is vdds_mlbp). For more information on the power supply name and the corresponding ball, see 表 4-2, POWER [11] column.

5.7.9 BC1833IHHV Buffers DC Electrical Characteristics

表 5-17 summarizes the DC electrical characteristics for BC1833IHHV Buffers.

表 5-17. BC1833IHHV Buffers DC Electrical Characteristics

PARAMETER		MIN	NOM	MAX	UNIT
Signal Names in MUXMODE 0: on_off;					
Balls: Y11;					
1.8-V Mode					
V_{OH}	Output high-level threshold ($I_{OH} = 2\text{ mA}$)	$V_{DDS}-0.45$			V
V_{OL}	Output low-level threshold ($I_{OL} = 2\text{ mA}$)			0.45	V
I_{DRIVE}	Pin Drive strength at PAD Voltage = 0.45V or $V_{DDS}-0.45V$	6			mA
I_{IN}	Input current at each I/O pin	6		12	μA
I_{OZ}	$I_{OZ}(I_{PAD}$ Current) for BIDI cell. This current is contributed by the tristated driver leakage + input current of the Rx + weak pullup/pulldown leakage. PAD is swept from 0 to V_{DDS} and the $Max(I_{PAD})$ is measured and is reported as I_{OZ}			6	μA
C_{PAD}	Pad capacitance (including package capacitance)			4	pF
3.3-V Mode					
V_{OH}	Output high-level threshold ($I_{OH} = 100\mu A$)	$V_{DDS}-0.2$			V
V_{OL}	Output low-level threshold ($I_{OL} = 100\mu A$)			0.2	V
I_{DRIVE}	Pin Drive strength at PAD Voltage = 0.45V or $V_{DDS}-0.45V$	6			mA
I_{IN}	Input current at each I/O pin			60	μA
I_{OZ}	$I_{OZ}(I_{PAD}$ Current) for BIDI cell. This current is contributed by the tristated driver leakage + input current of the Rx + weak pullup/pulldown leakage. PAD is swept from 0 to V_{DDS} and the $Max(I_{PAD})$ is measured and is reported as I_{OZ}			60	μA
C_{PAD}	Pad capacitance (including package capacitance)			4	pF

(1) VDDS stands for corresponding power supply (that is vddshv5). For more information on the power supply name and the corresponding ball, see 表 4-2, POWER [11] column.

5.7.10 USBPHY DC Electrical Characteristics

注: USB1 instance is compliant with the USB3.0 SuperSpeed Transmitter and Receiver Normative Electrical Parameters as defined in the USB3.0 Specification Rev 1.0 dated Jun 6, 2011.

注: USB1 and USB2 Electrical Characteristics are compliant with USB2.0 Specification Rev 2.0 dated April 27, 2000 including ECNs and Errata as applicable.

5.7.11 Dual Voltage SDIO1833 DC Electrical Characteristics

表 5-18 summarizes the DC electrical characteristics for Dual Voltage SDIO1833 Buffers.

表 5-18. Dual Voltage SDIO1833 DC Electrical Characteristics

PARAMETER		MIN	NOM	MAX	UNIT
Signal Names in Mode 0: mmc1_clk, mmc1_cmd, mmc1_data[3:0]					
Bottom Balls: W6 / Y6 / AA6 / Y4 / AA5 / Y3					
1.8-V Mode					
V _{IH}	Input high-level threshold	1.27			V
V _{IL}	Input low-level threshold			0.58	V
V _{HYS}	Input hysteresis voltage	50 ⁽²⁾			mV
I _{IN}	Input current at each I/O pin			30	μA
I _{OZ}	I _{OZ} (I _{PAD} Current) for BIDI cell. This current is contributed by the tristated driver leakage + input current of the Rx + weak pullup/pulldown leakage. PAD is swept from 0 to VDD5 and the Max(I(PAD)) is measured and is reported as I _{OZ}			30	μA
I _{IN} with pulldown enabled	Input current at each I/O pin with weak pulldown enabled measured when PAD = VDD5	50	120	210	μA
I _{IN} with pullup enabled	Input current at each I/O pin with weak pullup enabled measured when PAD = 0	60	120	200	μA
C _{PAD}	Pad capacitance (including package capacitance)			5	pF
V _{OH}	Output high-level threshold (I _{OH} = 2 mA)	1.4			V
V _{OL}	Output low-level threshold (I _{OL} = 2 mA)			0.45	V
3.3-V Mode					
V _{IH}	Input high-level threshold	0.625 × VDD5			V
V _{IL}	Input low-level threshold			0.25 × VDD5	V
V _{HYS}	Input hysteresis voltage	40 ⁽²⁾			mV
I _{IN}	Input current at each I/O pin			110	μA
I _{OZ}	I _{OZ} (I _{PAD} Current) for BIDI cell. This current is contributed by the tristated driver leakage + input current of the Rx + weak pullup/pulldown leakage. PAD is swept from 0 to VDD5 and the Max(I(PAD)) is measured and is reported as I _{OZ}			110	μA
I _{IN} with pulldown enabled	Input current at each I/O pin with weak pulldown enabled measured when PAD = VDD5	40	100	290	μA
I _{IN} with pullup enabled	Input current at each I/O pin with weak pullup enabled measured when PAD = 0	10	100	290	μA
C _{PAD}	Pad capacitance (including package capacitance)			5	pF
V _{OH}	Output high-level threshold (I _{OH} = 2 mA)	0.75 × VDD5			V
V _{OL}	Output low-level threshold (I _{OL} = 2 mA)			0.125 × VDD5	V

(1) VDD5 stands for corresponding power supply (that is vddshv8). For more information on the power supply name and the corresponding ball, see 表 4-2, POWER [11] column.

(2) Hysteresis is enabled/disabled with CTRL_CORE_CONTROL_HYST_1.SDCARD_HYST register.

5.7.12 Dual Voltage LVCMOS DC Electrical Characteristics

表 5-19 summarizes the DC electrical characteristics for Dual Voltage LVCMOS Buffers.

表 5-19. Dual Voltage LVC MOS DC Electrical Characteristics

PARAMETER		MIN	NOM	MAX	UNIT
1.8-V Mode					
V _{IH}	Input high-level threshold	0.65*V _{DD5}			V
V _{IL}	Input low-level threshold			0.35*V _{DD5}	V
V _{HYS}	Input hysteresis voltage	100			mV
V _{OH}	Output high-level threshold (I _{OH} = 2 mA)	V _{DD5} -0.45			V
V _{OL}	Output low-level threshold (I _{OL} = 2 mA)			0.45	V
I _{DRIVE}	Pin Drive strength at PAD Voltage = 0.45V or V _{DD5} -0.45V	6			mA
I _{IN}	Input current at each I/O pin			16	μA
I _{OZ}	I _{OZ} (I _{PAD} Current) for BIDI cell. This current is contributed by the tristated driver leakage + input current of the Rx + weak pullup/pulldown leakage. PAD is swept from 0 to V _{DD5} and the Max(I _{I(PAD)}) is measured and is reported as I _{OZ}			16	μA
I _{IN} with pulldown enabled	Input current at each I/O pin with weak pulldown enabled measured when PAD = V _{DD5}	50	120	210	μA
I _{IN} with pullup enabled	Input current at each I/O pin with weak pullup enabled measured when PAD = 0	60	120	200	μA
C _{PAD}	Pad capacitance (including package capacitance)			4	pF
Z _O	Output impedance (drive strength)		40		Ω
3.3-V Mode					
V _{IH}	Input high-level threshold	2			V
V _{IL}	Input low-level threshold			0.8	V
V _{HYS}	Input hysteresis voltage	200			mV
V _{OH}	Output high-level threshold (I _{OH} = 100 μA)	V _{DD5} -0.2			V
V _{OL}	Output low-level threshold (I _{OL} = 100 μA)			0.2	V
I _{DRIVE}	Pin Drive strength at PAD Voltage = 0.45V or V _{DD5} -0.45V	6			mA
I _{IN}	Input current at each I/O pin			65	μA
I _{OZ}	I _{OZ} (I _{PAD} Current) for BIDI cell. This current is contributed by the tristated driver leakage + input current of the Rx + weak pullup/pulldown leakage. PAD is swept from 0 to V _{DD5} and the Max(I _{I(PAD)}) is measured and is reported as I _{OZ}			65	μA
I _{IN} with pulldown enabled	Input current at each I/O pin with weak pulldown enabled measured when PAD = V _{DD5}	40	100	200	μA
I _{IN} with pullup enabled	Input current at each I/O pin with weak pullup enabled measured when PAD = 0	10	100	290	μA
C _{PAD}	Pad capacitance (including package capacitance)			4	pF
Z _O	Output impedance (drive strength)		40		Ω

(1) V_{DD5} stands for corresponding power supply. For more information on the power supply name and the corresponding ball, see 表 4-2, POWER [11] column.

5.7.13 SATAPHY DC Electrical Characteristics

注: The SATA module is compliant with the electrical parameters specified in the SATA-I/O SATA Specification, Revision 3.2, August 7, 2013.

5.7.14 PCIEPHY DC Electrical Characteristics

注: The PCIe interfaces are compliant with the electrical parameters specified in PCI Express® Base Specification Revision 3.0.

5.8 Thermal Resistance Characteristics

For reliability and operability concerns, the maximum junction temperature of the Device has to be at or below the T_J value identified in 表 5-4, *Recommended Operating Conditions*.

A BCI compact thermal model for this Device is available and recommended for use when modeling thermal performance in a system.

Therefore, it is recommended to perform thermal simulations at the system level with the worst case device power consumption.

5.8.1 Package Thermal Characteristics

表 5-20 provides the thermal resistance characteristics for the package used on this device.

注: Power dissipation of 1.5 W and an ambient temperature of 85°C is assumed for ABC package.

表 5-20. Thermal Resistance Characteristics

NO.	PARAMETER	DESCRIPTION	°C/W ⁽¹⁾	AIR FLOW (m/s) ⁽²⁾
T1	$R_{\theta_{JC}}$	Junction-to-case	0.82	N/A
T2	$R_{\theta_{JB}}$	Junction-to-board	3.78	N/A
T3	$R_{\theta_{JA}}$	Junction-to-free air	11.1	0
T4			8.8	1
T5		Junction-to-moving air	8.0	2
T6			7.5	3
T7	Ψ_{JT}	Junction-to-package top	0.62	0
T8			0.66	1
T9			0.66	2
T10			0.66	3
T11	Ψ_{JB}	Junction-to-board	3.43	0
T12			3.22	1
T13			3.12	2
T14			3.04	3

(1) These values are based on a JEDEC defined 2S2P system (with the exception of the θ_{JC} [$R_{\theta_{JC}}$] value, which is based on a JEDEC defined 1S0P system) and will change based on environment as well as application. For more information, see these EIA/JEDEC standards:

- JESD51-2, *Integrated Circuits Thermal Test Method Environment Conditions - Natural Convection (Still Air)*
- JESD51-3, *Low Effective Thermal Conductivity Test Board for Leaded Surface Mount Packages*
- JESD51-6, *Integrated Circuit Thermal Test Method Environmental Conditions - Forced Convection (Moving Air)*
- JESD51-7, *High Effective Thermal Conductivity Test Board for Leaded Surface Mount Packages*
- JESD51-9, *Test Boards for Area Array Surface Mount Packages*

(2) m/s = meters per second

5.9 Power Supply Sequences

This section describes the power-up and power-down sequence required to ensure proper device operation. The power supply names described in this section comprise a superset of a family of compatible devices. Some members of this family will not include a subset of these power supplies and their associated device modules. Refer to the [4.2, Ball Characteristics](#) of the [4, Terminal Configuration and Functions](#) to determine which power supplies are applicable.

[☒ 5-2](#) and [☒ 5-3](#) describe the device Power Sequencing.

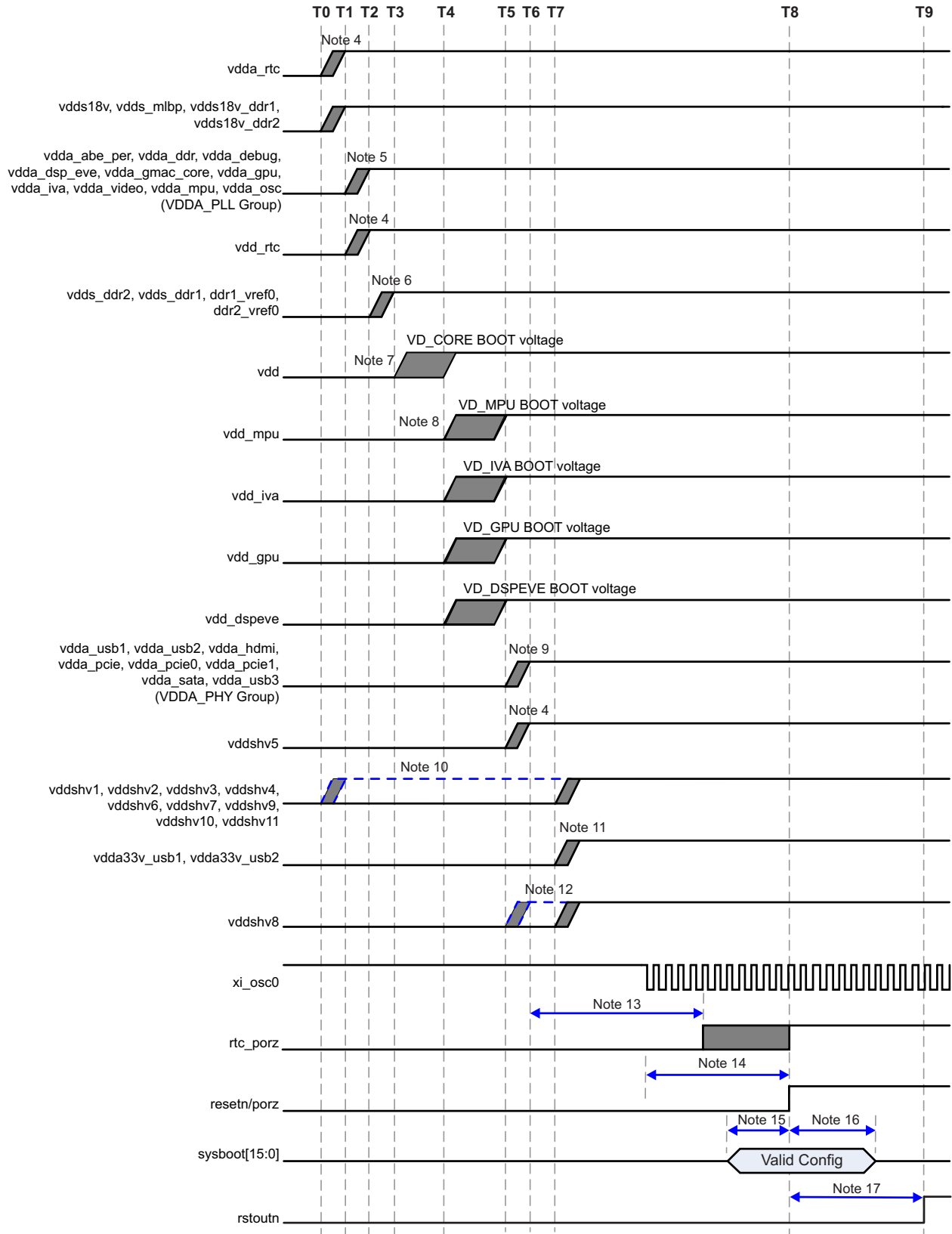

SPRS85V_ELCH_01

5-2. Recommended Power-Up Sequencing

(1) Time stamps:

- T0 = 0 ms; T1 = 0.55 ms; T2 = 1.1 ms; T3 = 1.65 ms; T4 = 2.2 ms; T5 = 2.75 ms; T6 = 3.3 ms; T7 = 5.85 ms; T8 = 6.4 ms; T9 = 8.4

ms. All “Tn” markers show total elapsed time from T0.

- (2) Terminology:
 - $V_{OPR\ MIN}$ = Minimum Operational Voltage level that ensures device functionality and specified performance per 5.4, *Recommended Operating Conditions*.
 - Ramp Up = transition time from V_{OFF} to $V_{OPR\ MIN}$.
- (3) General timing diagram items:
 - Grey shaded areas show valid transition times for supplies between $V_{OPR\ MIN}$ and V_{OFF} .
 - Dashed horizontal lines are not valid ramp times but show alternate transition times based upon common sources and clarified in associated note.
 - Dashed vertical lines show approximate elapse times based upon TI recommended PMIC power sequencer circuit performance.
- (4) vddshv5, vdd_rtc, and vdda_rtc domains:
 - If RTC mode is used, then vdda_rtc, vdd_rtc and vddshv5 must be individually powered with separate power supplies and cannot be combined with other rails.
 - If RTC-mode is not supported then the following combinations are approved:
 - vdda_rtc can be combined with vdds18v
 - vdd_rtc can be combined with vdd
 - vddshv5 can be combined with other 1.8 V or 3.3 V vddshvn rails
 If combinations listed above are not followed then sequencing for these 3 voltage rails should follow the RTC mode timing requirements.
- (5) vdda_* rails should not be combined with vdds18v_* for best performance to avoid transient switching noise impacts on analog domains. vdda_* should not ramp-up before vdds18v_* but could ramp concurrently if design ensures final operational voltage will not be reached until after vdds18v. The preferred sequence is to follow all vdds18v_* to ensure circuit components and PCB design do not cause an inadvertent violation.
- (6) vdds_dds* should not ramp-up before vdds18v_*. The preferred sequence has vdds_dds1 following vdds18v_* to ensure circuit components and PCB design do not cause an inadvertent violation. vdds_dds1 can ramp-up before, concurrently or after vdda_*, there are no dependencies between vdds_dds1 and vdda_* domains:
 - For DDR2 mode of operation (1.8 V), vdds_dds1 supplies can be combined with all vdds18v_* supplies and ramped up together for simplified PDN and power sequencing.
 - If vdds_dds1 is combined with vdds18v_dds1 but kept separate from vdds18v on board, then this combined 1.8 V DDR supply can come up together or after the vdds18v supply. The 1.8 V DDR supply should never ramp up before the vdds18v.
- (7) vdd should not ramp-up before vdds18v_* or vdds_dds* domains have reached $V_{OPR\ MIN}$.
- (8) vdd_mpu, vdd_iva, vdd_gpu, vdd_dspeve domains should follow vdd core supply as preferred sequence. If vdd_mpu, vdd_iva, vdd_gpu, vdd_dspeve domains ramp concurrently or quicker than vdd core, then vdd core must remain at least 150 mV greater than vdd_mpu, vdd_iva, vdd_gpu, vdd_dspeve domains during ramp. Circuit design (components and PCB) must ensure vdd reaches final operational voltage before any of the vdd_mpu, vdd_iva, vdd_gpu, vdd_dspeve domains.
- (9) VDDA_PHY group should not be combined with VDDA_PLL group to avoid transient switching noise impacts.
- (10) vddshv[1-4, 6, 7, 9-11] domains:
 - If 1.8 V I/O signaling is needed, then 1.8 V must be sourced from common vdds18v supply and ramp up concurrently with vdds18v.
 - If 3.3 V I/O signaling is needed, then 3.3 V vddshvx rails must ramp up after vdd_mpu, vdd_iva, vdd_gpu, vdd_dspeve, and VDDA_PHY group domains.
- (11) vdda33v_usb[1-2] domain:
 - If USB1 and USB2 interfaces are used, should be supplied from independent analog supply.
 - If USB1/USB2 interface is not used, could be connected to VSS/GND if both conditions are met:
 - USB1/USB2 diff pair (usb1_dm/usb1_dp; usb2_dm/usb2_dp) pins are left unconnected
 - vdda_usb1 and/or vdda_usb2 PHY is not energized
- (12) vddshv8 shows two ramp up options for 1.8 V I/O or 3.3 V I/O or SD Card operation:
 - If 1.8 V I/O signaling is needed, then vddshv8 must ramp up after vdd and before or concurrently with 3.3 V vddshv* rails.
 - If 3.3 V I/O signaling is needed, then vddshv8 must be combined with other 3.3 V vddshv* rails.
 - If SD Card operation is needed, then vddshv8 must be sourced from a dual voltage (3.3 V / 1.8 V) power source per SDIO specifications and ramp up concurrently with 3.3 V vddshv* rails.
- (13) Pulse duration: rtc_porz must remain low 1 ms after vdda_rtc, vddshv5, and vdd_rtc are ramped and stable or can be de-asserted before but no later than porz. The FUNK_32K_CLK source must be stable and at a valid frequency 1 ms prior to de-asserting rtc_porz high.
- (14) porz must remain asserted low until both of the following conditions are met:
 - Minimum of $12 \times P$, where $P = 1 / (\text{SYS_CLK1} / 610)$, units in ns.
 - All device supply rails reach stable operational levels.
- (15) Setup time: sysboot[15:0] pins must be valid $2P^{(14)}$ before porz is de-asserted high.
- (16) Hold time: sysboot[15:0] pins must be valid $15P^{(14)}$ after porz is de-asserted high.
- (17) rstoutn will be set high after global reset, due to porz, is de-asserted following an internal 2 ms delay. rstoutn is only valid after vddshv3 reaches an operational level. If used as a peripheral component reset, it should be AND gated with porz to avoid possible reset glitches during power up.

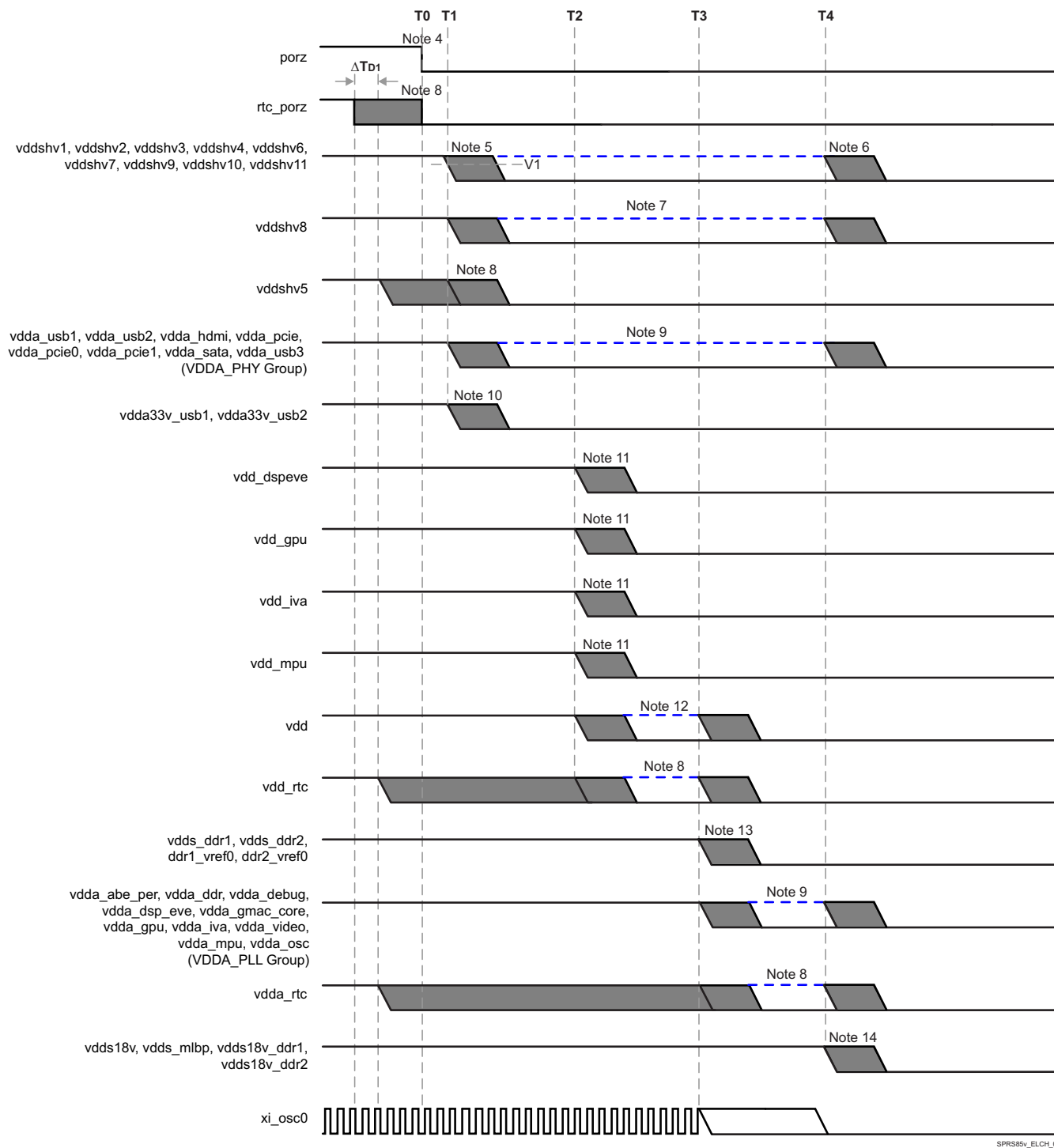

5-3. Recommended Power-Down Sequencing

- (1) Time stamps:
 - T0 = 0 ms, T1 > 100 μ s, T2 = 0.5 ms, T3 = 1.0 ms, T4 = 1.5 ms; V1 = 2.7 V. All “Tn” markers are intended to show elapsed times from T0. Delta time: ΔT_{D1} > 100 μ s.
- (2) Terminology:
 - $V_{OPR\ MIN}$ = Minimum Operational Voltage level that ensures device functionality and specified performance per 5.4, *Recommended Operating Conditions*.
 - V_{OFF} = OFF Voltage level is defined to be less than 0.6 V where any current draw has no impact to POH.
 - Ramp Down = transition time from $V_{OPR\ MIN}$ to V_{OFF} and is slew rate independent.
- (3) General timing diagram items:

- Grey shaded areas show valid transition times for supplies between $V_{OPR\ MIN}$ and V_{OFF} .
 - Dashed horizontal lines are not valid ramp times but show alternate transition times based upon common sources and clarified in associated note.
 - Dashed vertical lines show approximate elapse times based upon TI recommended PMIC power-down sequencer circuit performance.
- (4) porz signals must be asserted low for 100 μ s min to ensure SoC is set to a safe functional state before any voltage begins to ramp down.
- (5) vddshv* domains supplied by 3.3 V:
- must remain greater than 2.7 V to enable Dual Voltage GPIO selector circuit operation for 100 μ s min after porz is asserted low.
 - must be in first group of supplies ramping down after porz has been asserted low for 100 μ s min.
 - must not exceed vdds18v by more than 2 V during ramp down, see [Figure 5-7](#) “vdds18v and vdda_* Discharge Relationship”.
- (6) vddshv* domains supplied by 1.8 V:
- must ramp down concurrently with vdds18v and be sourced from the same vdds18v supply.
- (7) vddshv8 domain:
- must be in first group of supplies to ramp down after porz has been asserted low for 100 μ s min.
 - if SDIO operation is needed, must be sourced from independent power resource that can provide dual voltage (3.3 V / 1.8 V) operation as required to be compliant to SDIO specification
 - if SDIO operation is not needed, must be grouped and ramped down with other vddshv* domains as noted above.
- (8) RTC domains (vddshv5, vdd_rtc, and vdda_rtc):
- If RTC mode is used:
 - rtc_porz can be asserted low before porz and RTC domains can be ramped down after 100 μ s elapsed time.
 - must be sourced from independent supplies and must not be combined with other rails.
 - timing diagram shows this mode of operation.
 - If RTC mode is not used, then:
 - rtc_porz must be connected to porz signal.
 - vddshv5 must be grouped and ramped down with other vddshv* domains as noted above.
 - vdd_rtc must be grouped and ramped down with vdd.
 - vdda_rtc must be grouped and ramped down with either VDDA_PHY group or vdds18v.
- (9) vdda_* domains:
- should not be combined with vdds18v for best performance to avoid transient switching noise impacts on analog domains.
 - can ramp down before or concurrently with vdds18v.
 - must satisfy the vdds18v and vdda_* Discharge Relationship (see [Figure 5-7](#)) if vdda_* disable point is later or discharge rate is slower than vdds18v.
 - can ramp down before, concurrently or after vdds_dds*, there is no dependency between these supplies.
- (10) vdda33v_usb* domains:
- can start ramping down 100 μ s after low assertion of porz
 - can ramp down concurrently or before VDDA_PHY group
- (11) vdd_dspeve, vdd_gpu, vdd_iva, vdd_mpu domains can ramp down before or concurrently with vdd.
- (12) vdd can ramp down concurrently or after with vdd_dspeve, vdd_gpu, vdd_iva, vdd_mpu domains.
- (13) vdds_dds* domains:
- should ramp down after vdd begins ramping down.
 - If DDR2 memory is used (requiring 1.8 V supply):
 - then vdds_dds* can be combined with vdds18v and vdds18v_dds* domains and sourced from a common supply. Accordingly, all domains can ramp down concurrently with vdds18v
 - if vdds_dds* and vdds18v_dds* are combined but kept separate from vdds18v, then the combined 1.8 V DDR supply can ramp down before or concurrently with vdds18v
- (14) vdds18v domain:
- should maintain $V_{OPR\ MIN}$ ($V_{NOM} - 5\% = 1.71$ V) until all other supplies start to ramp down.
 - must satisfy the vdds18v versus vddshv[1-7, 9-11] Discharge Relationship (see [Figure 5-5](#)) if vddshv* is operating at 3.3 V
 - must satisfy the vdds18v and vdds_dds* Discharge Relationship (see [Figure 5-6](#)) if vdds_dds* discharge rate is slower than vdds18v.

☒ 5-4 describes the RTC-mode Power Sequencing.

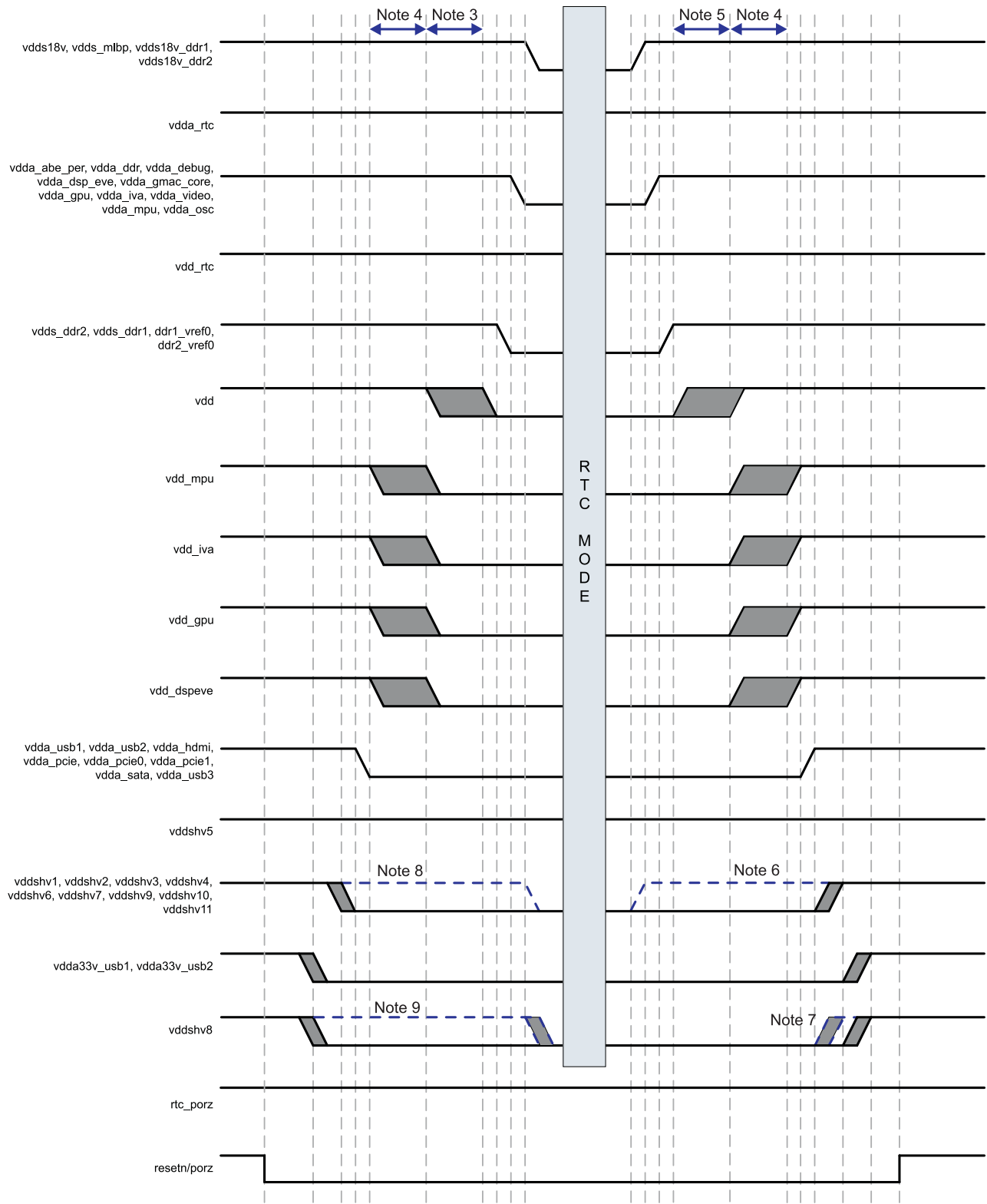

SPRS85V_ELCH_03

☒ 5-4. RTC Mode Sequencing

(1) Grey shaded areas are windows where it is valid to ramp the voltage rail.

- (2) Blue dashed lines are not valid windows but show alternate ramp possibilities based on the associated note.
- (3) vdd must ramp down after or at the same time as vdd_mpu, vdd_gpu, vdd_dspeve and vdd_iva.
- (4) vdd_mpu, vdd_gpu, vdd_dspeve, vdd_iva can be ramped at the same time or can be staggered.
- (5) vdd must ramp up before or at the same time as vdd_mpu, vdd_gpu, vdd_dspeve and vdd_iva.
- (6) If any of the vddshv[1-7,9-11] rails (not including vddshv8) are used as 1.8V only, then these rails can be combined with vdds18v.
- (7) vddshv8 is separated out to show support for dual voltage. If single voltage is used then vddshv8 can be combined with other vddshvn rails but vddshv8 must ramp down before vdd and must ramp up after vdd.
- (8) If any of the vddshv[1-7,9-11] rails (not including vddshv8) are used as 1.8V only, then these rails can be combined with vdds18v. vddshv[1-7,9-11] is allowed to ramp down at either of the two points shown in the timing diagram in either 1.8V mode or in 3.3V mode. If vddshv[1-7,9-11] ramps down at the later time in the diagram then the board design must ensure that the vddshvn rail is never higher than 2.0 V above the vdds18v rail.
- (9) vddshv8 is separated out to show support for dual voltage. If a dedicated LDO/supply source is used for vddshv8, then vddshv8 ramp down should occur at one of the two earliest points in the timing diagram. If vddshv8 is powered by the same supply source as the other vddshvn rails, then it is allowed to ramp down at either of the last two points in the timing diagram.

☒ 5-5 describes vddshv[1-7,9-11] Supplies Falling Before vdds18v Supplies Delta.

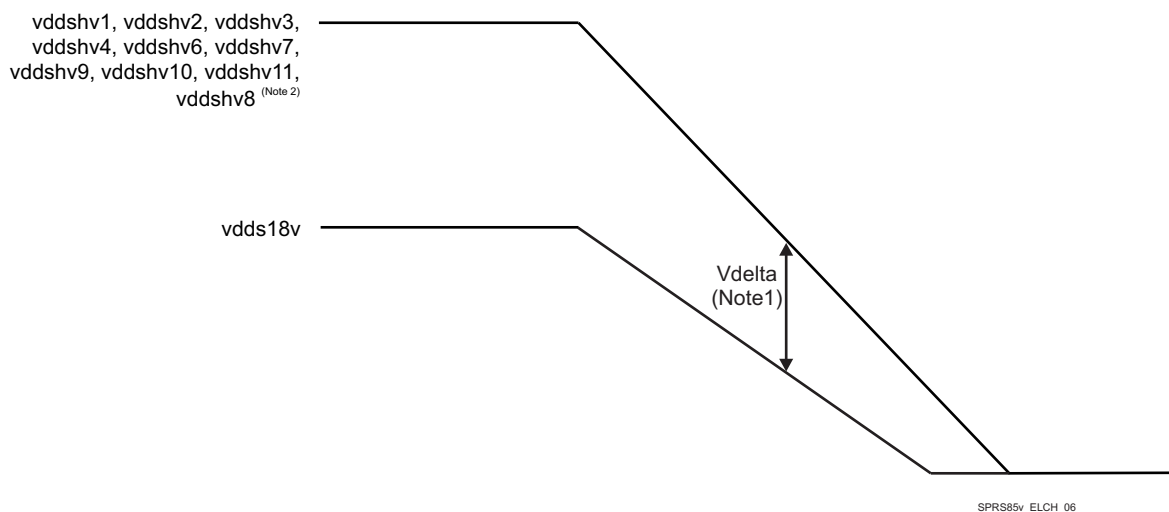

☒ 5-5. vdds18v versus vddshv[1-7, 9-11] Discharge Relationship

- (1) Vdelta MAX = 2V
- (2) If vddshv8 is powered by the same supply source as the other vddshv[1-7,9-11] rails.

If vdds18v and vdds_dds* are disabled at the same time due to a loss of input power event or if vdds_dds* discharges more slowly than vdds18v, analysis has shown no reliability impacts when the elapsed time period beginning with vdds18v dropping below 1.0 V and ending with vdds_dds* dropping below 0.6 V is less than 10 ms (☒ 5-6).

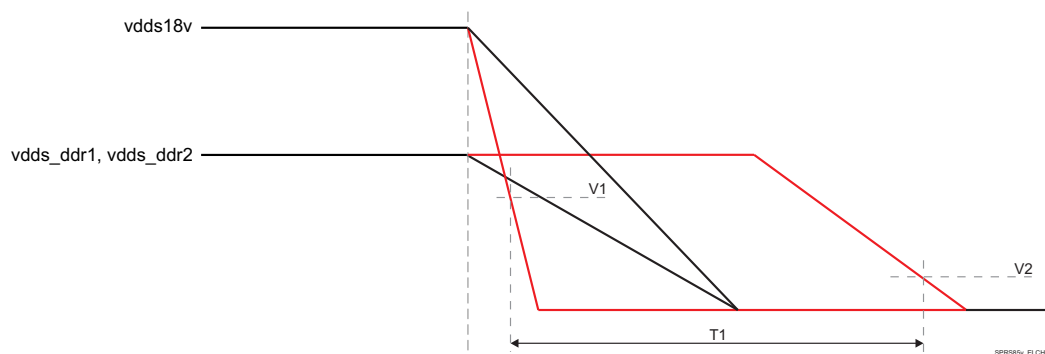

☒ 5-6. vdds18v and vdds_dds* Discharge Relationship⁽¹⁾

- (1) V1 > 1.0 V; V2 < 0.6V; T1 < 10ms.

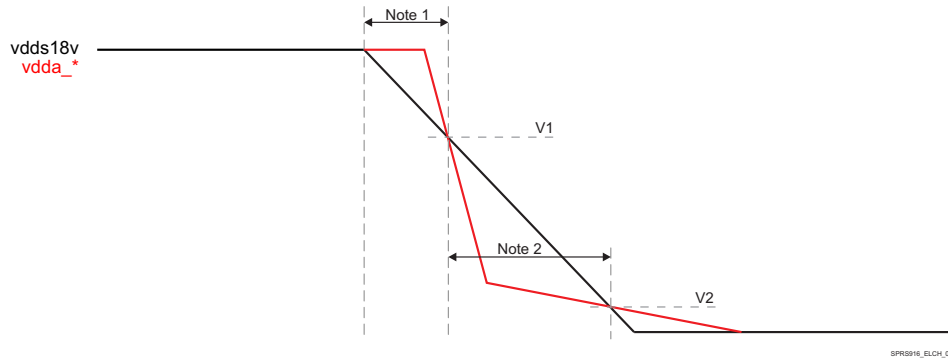

Figure 5-7. vdds18v and vdda_* Discharge Relationship⁽³⁾

- (1) vdda_* can be \geq vdds18v, until vdds18v drops below 1.62 V.
- (2) vdds18v must be \geq vdda_*, until vdds18v reaches 0.6 V.
- (3) $V1 = 1.62$ V; $V2 < 0.6$ V.

Figure 5-5 through Figure 5-8 and associated notes described the device abrupt power down sequence.

A "loss of input power event" occurs when the system's input power is unexpectedly removed. Normally, the recommended power-down sequence should be followed and can be accomplished within 1.5-2 ms of elapsed time. This is the typical range of elapsed time available following a loss of power event, see 8.3.7 for design recommendations. If sufficient elapse time is not provided, then an "abrupt" power down sequence can be supported without impacting POH reliability if all of the following conditions are met (Figure 5-8).

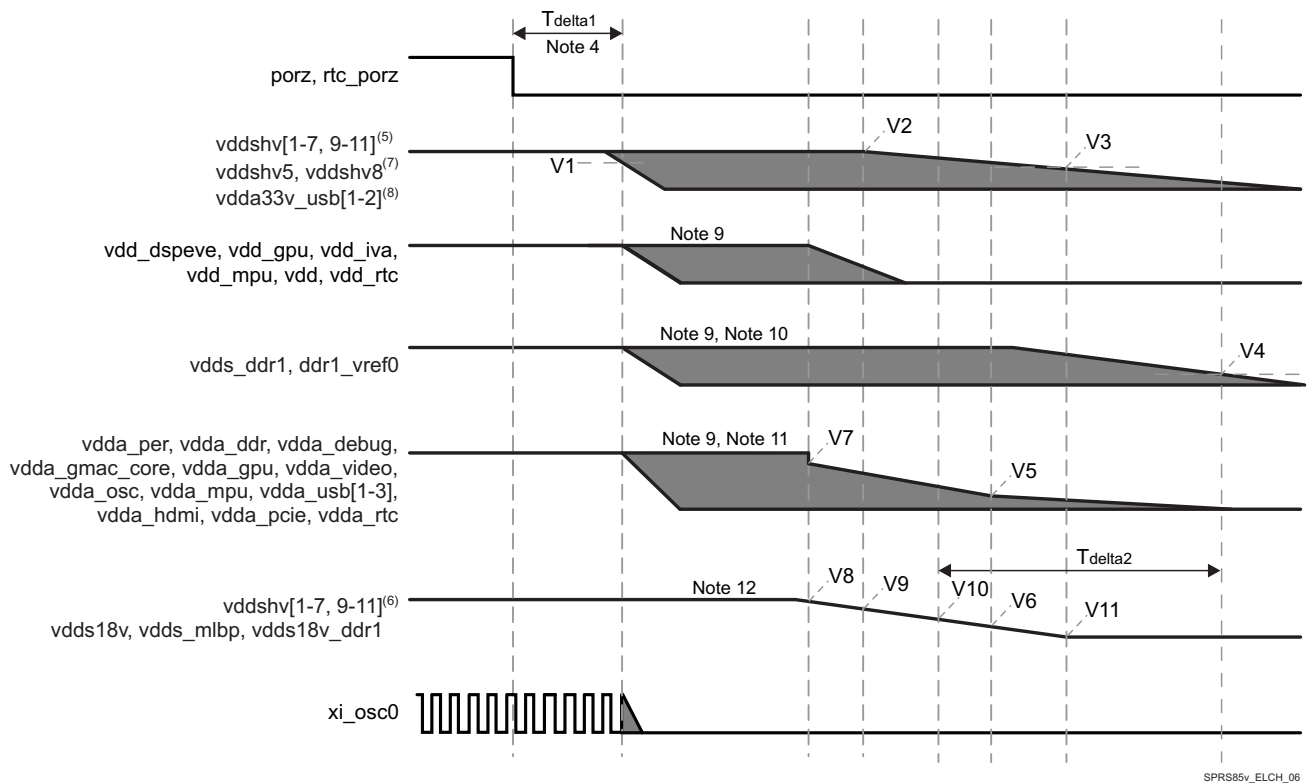

Figure 5-8. Abrupt Power-Down Sequencing⁽¹⁾

- (1) Time stamps:
 - $V1 = 2.7$ V; $V2 = 3.3$ V; $V3 = 2.0$ V; $V4 = V5 = V6 = 0.6$ V; $V7 = V8 = 1.62$ V; $V9 = 1.3$ V; $V10 = 1.0$ V; $V11 = 0.0$ V; $T_{\delta 1} > 100$ μ s; $T_{\delta 2} < 10$ ms.

- (2) Terminology:
 - $V_{OPR\ MIN}$ = Minimum Operational Voltage level that ensures device functionality and specified performance in 5.4, *Recommended Operating Conditions table*.
 - V_{OFF} = OFF Voltage level is defined to be less than 0.6 V, where any current draw has no impact to POH.
 - Ramp Down = transition time from $V_{OPR\ MIN}$ to V_{OFF} and is slew rate independent.
- (3) General timing diagram items:
 - Grey shaded areas show valid transition times for supplies between $V_{OPR\ MIN}$ and V_{OFF} .
 - Dashed vertical lines show approximate elapse times based upon TI recommended PMIC power-down sequencer circuit performance.
- (4) porz and rtc_porz must be asserted low for 100 μ s min to ensure SoC is set to a safe functional state before any voltage begins to ramp down.
 - Only if using RTC-mode with an independent RTC input power source, then rtc_porz can remain high and RTC-domains (vdd_rtc, vdda_rtc, and vddshv5) can remain energized while all other domains sourced from the system input power are powered down.
- (5) vddshv[1-7, 9-11] domains supplied by 3.3 V:
 - must remain greater than 2.7 V to enable Dual Voltage GPIO selector circuit operation for 100 μ s min, after porz is asserted low.
 - must not exceed vdds18v voltage level by more than 2 V during ramp down, until vdds18v drops below V_{OFF} (0.6 V).
- (6) vddshv[1-7, 9-11] domains supplied by 1.8 V must ramp down concurrently with vdds18v and be sourced from common vdds18v supply.
- (7) vddshv8 supporting SD Card:
 - must be in first group of supplies to ramp down after porz has been asserted low for 100 μ s min.
 - must be sourced from independent power resource that can provide dual voltage (3.3 V / 1.8 V) operation as required to be compliant to SDIO specification.
 - if SDIO operation is not needed, must be grouped with other vddshv[1-7, 9-11] domains.
- (8) vdda33v_usb[1-2] domains must be in first group of supplies to ramp down after porz has been asserted low for 100 μ s min.
- (9) vdd_dspeve, vdd_gpu, vdd_iva, vdd_mpu, vdd, vdd_rtc, vdds_dds1, vdda_* domains can all start to ramp down in any order after 100 μ s low assertion of porz.
- (10) vdds_dds1 domains:
 - can remain at $V_{OPR\ MIN}$ or a level greater than vdds18v during ramp down.
 - elapsed time from vdds18v dropping below 1.0 V to vdds_dds1[1-3] dropping below 0.6 V must not exceed 10 ms.
- (11) vdda_* domains:
 - can start to ramp down before or concurrently with vdds18v.
 - must not exceed vdds18v voltage level after vdds18v drops below 1.62 V until vdds18v drops below V_{OFF} (0.6 V).
- (12) vdds18v domain should maintain a minimum level of 1.62 V ($V_{NOM} - 10\%$) until vdd_dspeve and vdd start to ramp down.

6 Clock Specifications

注: For more information, see Power, Reset, and Clock Management / PRCM Environment / External Clock Signal and Power Reset / PRCM Functional Description / PRCM Clock Manager Functional Description section of the Device TRM.

注: Audio Back End (ABE) module is not supported for this family of devices, but “ABE” name is still present in some clock or DPLL names.

The device operation requires the following clocks:

- The 32 kHz frequency is used for low frequency operation. It supplies the wake-up domain for operation in lowest power mode. This is an optional clock and will be supplied by on chip divider + mux (FUNC_32K_CLK) incase it is not available on external pin.
- The system clocks, SYS_CLK1 (Mandatory) and SYS_CLK2 (Optional) are the main clock sources of the device. They supply the reference clock to the DPLLs as well as functional clock to several modules.

The Device also embeds an internal free-running 32-kHz oscillator that is always active as long as the the wake-up (WKUP) domain is supplied.

☒ 6-1 shows the external input clock sources and the output clocks to peripherals.

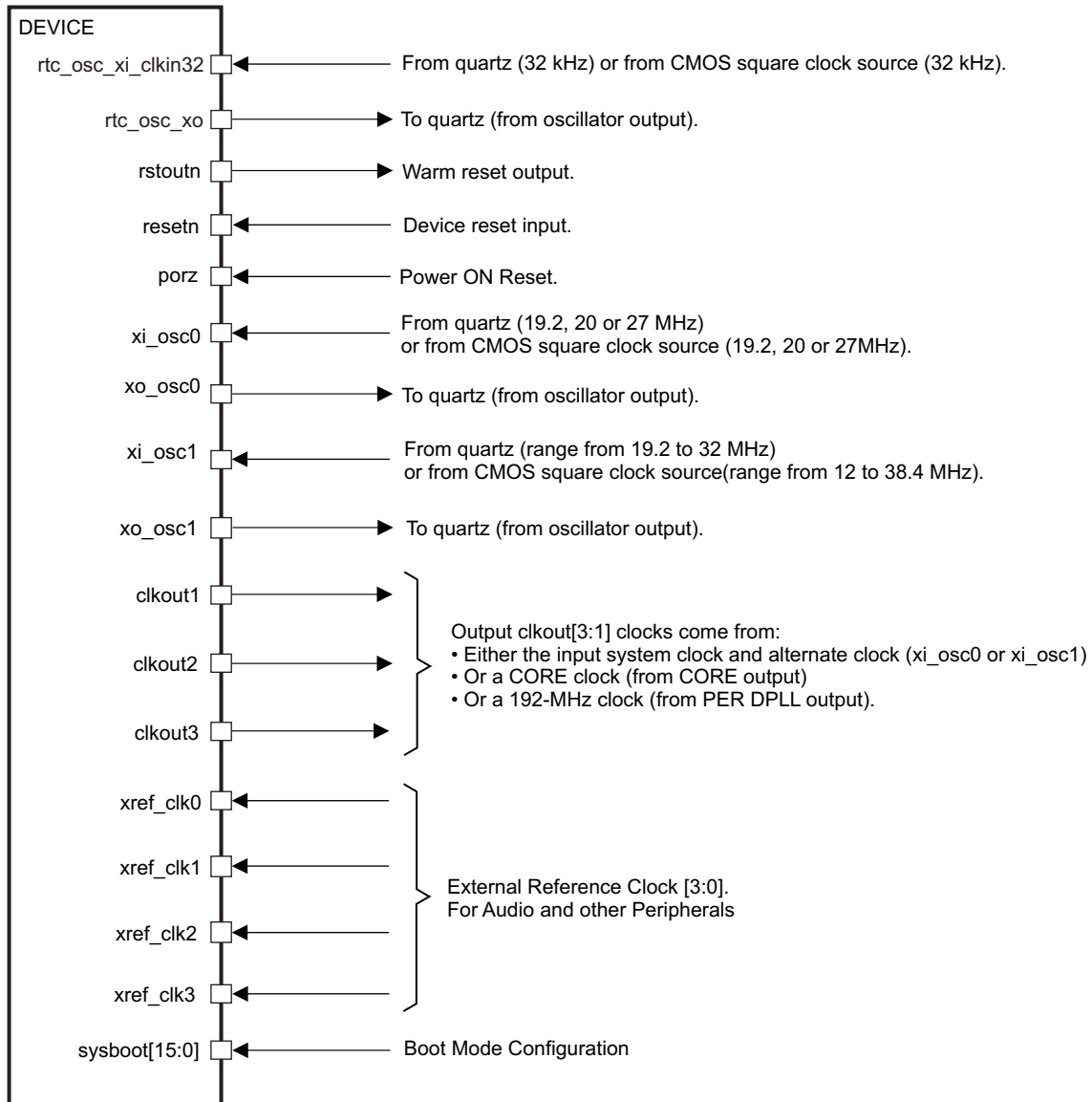

FIG 6-1. Clock Interface

6.1 Input Clock Specifications

6.1.1 Input Clock Requirements

- The source of the internal system clock (SYS_CLK1) could be either:
 - A CMOS clock that enters on the xi_osc0 ball (with xo_osc0 left unconnected on the CMOS clock case).
 - A crystal oscillator clock managed by xi_osc0 and xo_osc0.
- The source of the internal system clock (SYS_CLK2) could be either:
 - A CMOS clock that enters on the xi_osc1 ball (with xo_osc1 left unconnected on the CMOS clock case).
 - A crystal oscillator clock managed by xi_osc1 and xo_osc1.
- The source of the internal system clock (FUNC_32K_CLK) could be either:
 - A CMOS clock that enters on the rtc_osc_xi_clkin32 ball and supports external LVCMOS clock generators
 - A crystal oscillator clock managed by rtc_osc_xi_clkin32 and rtc_osc_xo.

6.1.2 System Oscillator OSC0 Input Clock

SYS_CLK1 is received directly from oscillator OSC0. For more information about SYS_CLK1 see Device TRM, Chapter: *Power, Reset, and Clock Management*.

6.1.2.1 OSC0 External Crystal

An external crystal is connected to the device pins. [Figure 6-2](#) describes the crystal implementation.

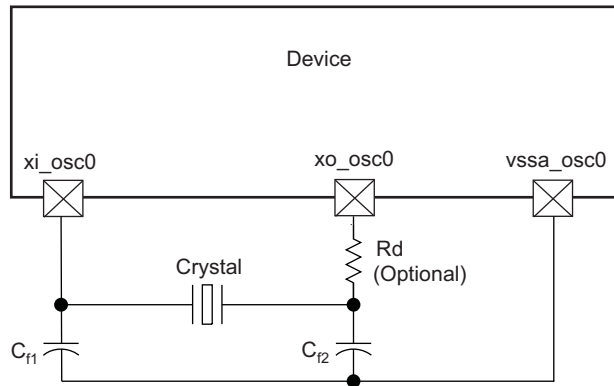

Figure 6-2. Crystal Implementation

注: The load capacitors, C_{f1} and C_{f2} in [Figure 6-2](#), should be chosen such that the below equation is satisfied. C_L in the equation is the load specified by the crystal manufacturer. All discrete components used to implement the oscillator circuit should be placed as close as possible to the associated oscillator xi_osc0 , xo_osc0 , and $vssa_osc0$ pins.

$$C_L = \frac{C_{f1} C_{f2}}{(C_{f1} + C_{f2})}$$

Figure 6-3. Load Capacitance Equation

The crystal must be in the fundamental mode of operation and parallel resonant. [Table 6-1](#) summarizes the required electrical constraints.

Table 6-1. OSC0 Crystal Electrical Characteristics

NAME	DESCRIPTION	MIN	TYP	MAX	UNIT	
f_p	Parallel resonance crystal frequency	19.2, 20, 27			MHz	
C_{f1}	C_{f1} load capacitance for crystal parallel resonance with $C_{f1} = C_{f2}$	12		24	pF	
C_{f2}	C_{f2} load capacitance for crystal parallel resonance with $C_{f1} = C_{f2}$	12		24	pF	
$ESR(C_{f1}, C_{f2})$	Crystal ESR			100	Ω	
C_O	Crystal shunt capacitance	ESR = 30 Ω	19.2 MHz, 20 MHz, 27 MHz		7	pF
		ESR = 50 Ω	19.2 MHz, 20 MHz		7	pF
			27 MHz		5	pF
		ESR = 60 Ω	19.2 MHz, 20 MHz		7	pF
			27 MHz		Not Supported	
		ESR = 80 Ω	19.2 MHz, 20 MHz		5	pF
27 MHz			Not Supported		-	
ESR = 100 Ω	19.2 MHz, 20 MHz		3	pF		
	27 MHz		Not Supported		-	

表 6-1. OSC0 Crystal Electrical Characteristics (continued)

NAME	DESCRIPTION	MIN	TYP	MAX	UNIT
L_M	Crystal motional inductance for $f_p = 20$ MHz		10.16		mH
C_M	Crystal motional capacitance		3.42		fF
$t_j(xiosc0)$	Frequency accuracy ⁽¹⁾ , xi_osc0	Ethernet and MLB not used		±200	ppm
		Ethernet RGMII and RMII using derived clock		±50	
		Ethernet MII using derived clock		±100	
		MLB using derived clock		±50	

(1) Crystal characteristics should account for tolerance+stability+aging.

When selecting a crystal, the system design must take into account the temperature and aging characteristics of a crystal versus the user environment and expected lifetime of the system.

表 6-2 details the switching characteristics of the oscillator and the requirements of the input clock.

表 6-2. Oscillator Switching Characteristics—Crystal Mode

NAME	DESCRIPTION	MIN	TYP	MAX	UNIT
f_p	Oscillation frequency		19.2, 20, 27 MHz		MHz
t_{sX}	Start-up time			4	ms

6.1.2.2 OSC0 Input Clock

A 1.8-V LVCMOS-Compatible Clock Input can be used instead of the internal oscillator to provide the SYS_CLK1 clock input to the system. The external connections to support this are shown in 图 6-4. The xi_osc0 pin is connected to the 1.8-V LVCMOS-Compatible clock source. The xi_osc0 pin is left unconnected. The vssa_osc0 pin is connected to board ground (VSS).



图 6-4. 1.8-V LVCMOS-Compatible Clock Input

表 6-3 summarizes the OSC0 input clock electrical characteristics.

表 6-3. OSC0 Input Clock Electrical Characteristics—Bypass Mode

NAME	DESCRIPTION	MIN	TYP	MAX	UNIT
f	Frequency		19.2, 20, 27		MHz
C_{IN}	Input capacitance	2.184	2.384	2.584	pF
I_{IN}	Input current (3.3V mode)	4	6	10	μA

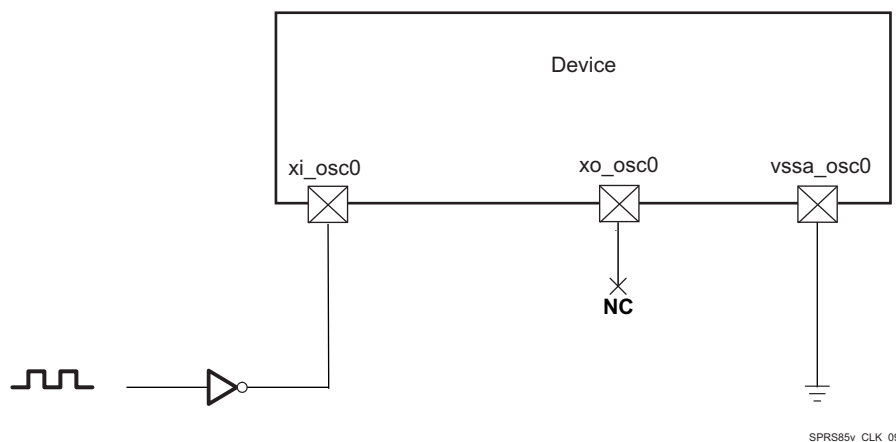
表 6-4 details the OSC0 input clock timing requirements.

表 6-4. OSC0 Input Clock Timing Requirements

NAME	DESCRIPTION		MIN	TYP	MAX	UNIT
CK0	$1 / t_{c(xi_osc0)}$	Frequency, xi_osc0	19.2, 20, 27			MHz
CK1	$t_{w(xi_osc0)}$	Pulse duration, xi_osc0 low or high	$0.45 * t_{c(xi_osc0)}$		$0.55 * t_{c(xi_osc0)}$	ns
	$t_{j(xi_osc0)}$	Period jitter ⁽¹⁾ , xi_osc0			$0.01 * t_{c(xi_osc0)}$	ns
	$t_{R(xi_osc0)}$	Rise time, xi_osc0			5	ns
	$t_{F(xi_osc0)}$	Fall time, xi_osc0			5	ns
	$t_{j(xi_osc0)}$	Frequency accuracy ⁽²⁾ , xi_osc0	Ethernet and MLB not used		± 200	ppm
			Ethernet RGMII and RMII using derived clock		± 50	
			Ethernet MII using derived clock		± 100	
			MLB using derived clock		± 50	

(1) Period jitter is meant here as follows:

- The maximum value is the difference between the longest measured clock period and the expected clock period
- The minimum value is the difference between the shortest measured clock period and the expected clock period

(2) Crystal characteristics should account for tolerance+stability+aging.



图 6-5. xi_osc0 Input Clock

6.1.3 Auxiliary Oscillator OSC1 Input Clock

SYS_CLK2 is received directly from oscillator OSC1. For more information about SYS_CLK2 see Device TRM, Chapter: Power, Reset, and Clock Management.

6.1.3.1 OSC1 External Crystal

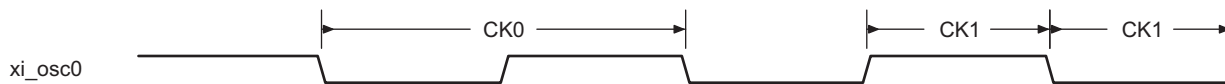
An external crystal is connected to the device pins. 图 6-6 describes the crystal implementation.



图 6-6. Crystal Implementation

注: The load capacitors, C_{f1} and C_{f2} in 图 6-6, should be chosen such that the below equation is satisfied. C_L in the equation is the load specified by the crystal manufacturer. All discrete components used to implement the oscillator circuit should be placed as close as possible to the associated oscillator xi_osc1, xo_osc1, and vssa_osc1 pins.

$$C_L = \frac{C_{f1} C_{f2}}{(C_{f1} + C_{f2})}$$

图 6-7. Load Capacitance Equation

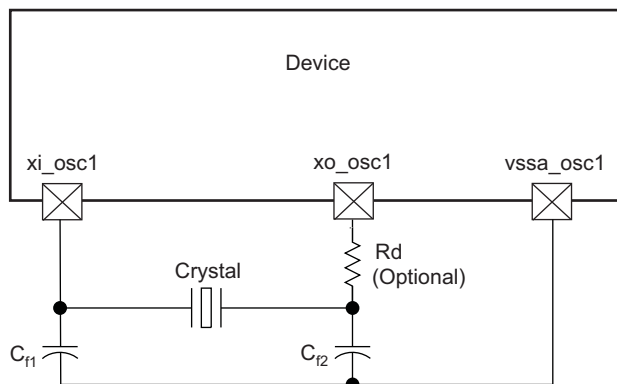
The crystal must be in the fundamental mode of operation and parallel resonant. 表 6-5 summarizes the required electrical constraints.

表 6-5. OSC1 Crystal Electrical Characteristics

NAME	DESCRIPTION		MIN	TYP	MAX	UNIT	
f_p	Parallel resonance crystal frequency		Range from 19.2 to 32			MHz	
C_{f1}	C_{f1} load capacitance for crystal parallel resonance with $C_{f1} = C_{f2}$		12		24	pF	
C_{f2}	C_{f2} load capacitance for crystal parallel resonance with $C_{f1} = C_{f2}$		12		24	pF	
ESR(C_{f1}, C_{f2})	Crystal ESR				100	Ω	
C_O	Crystal shunt capacitance	ESR = 30 Ω	19.2 MHz $\leq f_p \leq$ 32 MHz		7	pF	
		ESR = 40 Ω	19.2 MHz $\leq f_p \leq$ 32 MHz		5	pF	
		ESR = 50 Ω	19.2 MHz $\leq f_p \leq$ 25 MHz		7	pF	
			25 MHz $< f_p \leq$ 27 MHz		5	pF	
		ESR = 60 Ω	27 MHz $< f_p \leq$ 32 MHz		Not Supported		-
			19.2 MHz $\leq f_p \leq$ 23 MHz			7	pF
			23 MHz $< f_p \leq$ 25 MHz			5	pF
		ESR = 80 Ω	25 MHz $< f_p \leq$ 32 MHz		Not Supported		-
			19.2 MHz $\leq f_p \leq$ 23 MHz			5	pF
			23 MHz $\leq f_p \leq$ 25 MHz			3	pF
		ESR = 100 Ω	25 MHz $< f_p \leq$ 32 MHz		Not Supported		-
			19.2 MHz $\leq f_p \leq$ 20 MHz			3	pF
	20 MHz $< f_p \leq$ 32 MHz		Not Supported		-		
L_M	Crystal motional inductance for $f_p = 20$ MHz			10.16		mH	
C_M	Crystal motional capacitance			3.42		fF	
$f_{j(xiosc1)}$	Frequency accuracy ⁽¹⁾ , xi_osc1	Ethernet and MLB not used			± 200	ppm	
		Ethernet RGMII and RMII using derived clock			± 50		
		Ethernet MII using derived clock			± 100		
		MLB using derived clock			± 50		

(1) Crystal characteristics should account for tolerance+stability+aging.

When selecting a crystal, the system design must take into account the temperature and aging characteristics of a crystal versus the user environment and expected lifetime of the system.

表 6-6 details the switching characteristics of the oscillator and the requirements of the input clock.

表 6-6. Oscillator Switching Characteristics—Crystal Mode

NAME	DESCRIPTION	MIN	TYP	MAX	UNIT
f_p	Oscillation frequency	Range from 19.2 to 32			MHz
t_{sX}	Start-up time			4	ms

6.1.3.2 OSC1 Input Clock

A 1.8-V LVCMOS-Compatible Clock Input can be used instead of the internal oscillator to provide the SYS_CLK2 clock input to the system. The external connections to support this are shown in, 图 6-8. The xi_osc1 pin is connected to the 1.8-V LVCMOS-Compatible clock sources. The xo_osc1 pin is left unconnected. The vssa_osc1 pin is connected to board ground (vss).



图 6-8. 1.8-V LVCMOS-Compatible Clock Input

表 6-7 summarizes the OSC1 input clock electrical characteristics.

表 6-7. OSC1 Input Clock Electrical Characteristics—Bypass Mode

NAME	DESCRIPTION	MIN	TYP	MAX	UNIT
f	Frequency	Range from 12 to 38.4			MHz
C_i	Input capacitance	2.819	3.019	3.219	pF
I_i	Input current (3.3V mode)	4	6	10	μ A
t_{sX}	Start-up time ⁽¹⁾	See ⁽²⁾			ms

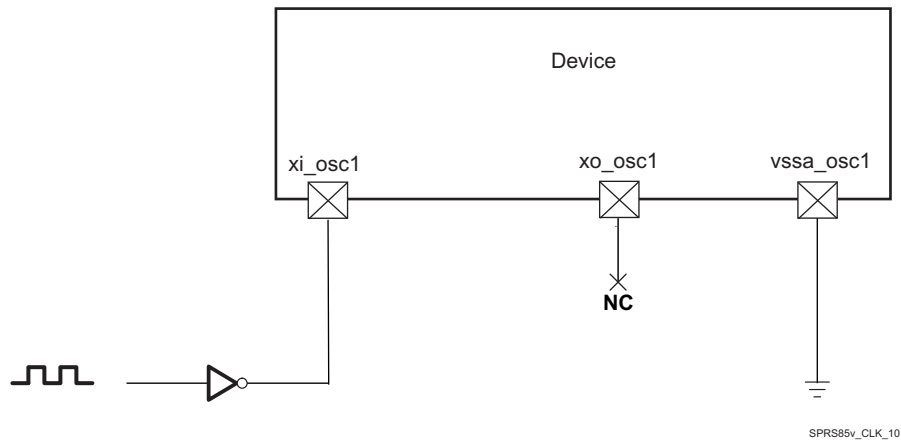
(1) To switch from bypass mode to crystal or from crystal mode to bypass mode, there is a waiting time about 100 μ s; however, if the chip comes from bypass mode to crystal mode the crystal will start-up after time mentioned in 表 6-6, t_{sX} parameter.

(2) Before the processor boots up and the oscillator is set to bypass mode, there is a waiting time when the internal oscillator is in application mode and receives a wave. The switching time in this case is about 100 μ s.

表 6-8 details the OSC1 input clock timing requirements.

表 6-8. OSC1 Input Clock Timing Requirements

NAME	DESCRIPTION		MIN	TYP	MAX	UNIT
CK0	$1 / t_{c(xiosc1)}$	Frequency, xi_osc1	Range from 12 to 38.4			MHz
CK1	$t_{w(xiosc1)}$	Pulse duration, xi_osc1 low or high	0.45 * $t_{c(xiosc1)}$		0.55 * $t_{c(xiosc1)}$	ns
	$t_{j(xiosc1)}$	Period jitter ⁽¹⁾ , xi_osc1			$0.01 \times t_{c(xiosc1)}$ ⁽³⁾	ns
	$t_{R(xiosc1)}$	Rise time, xi_osc1			5	ns
	$t_{F(xiosc1)}$	Fall time, xi_osc1			5	ns

表 6-8. OSC1 Input Clock Timing Requirements (continued)

NAME	DESCRIPTION		MIN	TYP	MAX	UNIT
$t_{j(xiosc1)}$	Frequency accuracy ⁽²⁾ , xi_osc1	Ethernet and MLB not used			±200	ppm
		Ethernet RGMII and RMII using derived clock			±50	
		Ethernet MII using derived clock			±100	
		MLB using derived clock			±50	

(1) Period jitter is meant here as follows:

- The maximum value is the difference between the longest measured clock period and the expected clock period
- The minimum value is the difference between the shortest measured clock period and the expected clock period

(2) Crystal characteristics should account for tolerance+stability+aging.

(3) The Period jitter requirement for osc1 can be relaxed to $0.02 \cdot t_c(xiosc1)$ under the following constraints:

- a. The osc1/SYS_CLK2 clock bypasses all device PLLs
- b. The osc1/SYS_CLK2 clock is only used to source the DSS pixel clock outputs



图 6-9. xi_osc1 Input Clock

6.1.4 RTC Oscillator Input Clock

FUNC_32K_CLK is received directly from RTC Oscillator. For more information about FUNC_32K_CLK see Device TRM, Chapter: *Power, Reset, and Clock Management*.

6.1.4.1 RTC Oscillator External Crystal

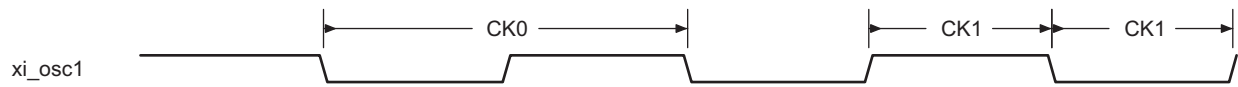
An external crystal is connected to the device pins. 图 6-2 describes the crystal implementation.



图 6-10. Crystal Implementation

注: The load capacitors, C_{f1} and C_{f2} in 图 6-10, should be chosen such that the below equation is satisfied. C_L in the equation is the load specified by the crystal manufacturer. All discrete components used to implement the oscillator circuit should be placed as close as possible to the associated oscillator $rtc_osc_xi_clkin32$ and rtc_osc_xo pins.

$$C_L = \frac{C_{f1} C_{f2}}{(C_{f1} + C_{f2})}$$

图 6-11. Load Capacitance Equation

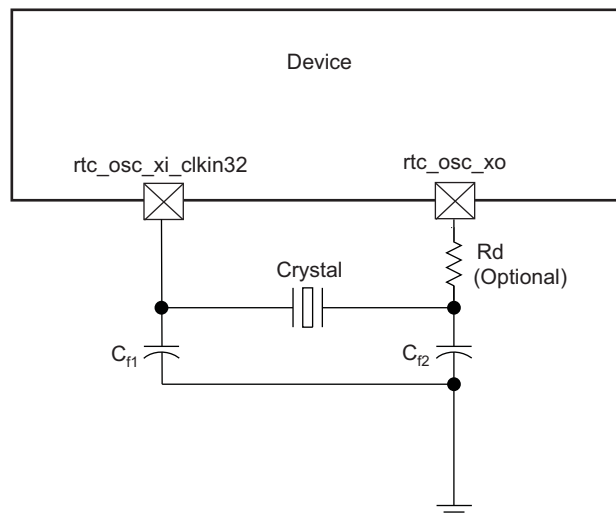
The crystal must be in the fundamental mode of operation and parallel resonant. 表 6-9 summarizes the required electrical constraints.

表 6-9. RTC Crystal Electrical Characteristics

NAME	DESCRIPTION	MIN	TYP	MAX	UNIT
f_p	Parallel resonance crystal frequency	32.768			kHz
C_{f1}	C_{f1} load capacitance for crystal parallel resonance with $C_{f1} = C_{f2}$	12		24	pF
C_{f2}	C_{f2} load capacitance for crystal parallel resonance with $C_{f1} = C_{f2}$	12		24	pF
$ESR(C_{f1}, C_{f2})$	Crystal ESR			80	kΩ
C_O	Crystal shunt capacitance			5	pF
L_M	Crystal motional inductance for $f_p = 32,768$ kHz		10.7		mH
C_M	Crystal motional capacitance		2.2		fF
$t_{j(rtc_osc_xi_clk32)}$	Frequency accuracy, rtc_osc_xi_clk32			±200	ppm

When selecting a crystal, the system design must take into account the temperature and aging characteristics of a crystal versus the user environment and expected lifetime of the system.

表 6-10 details the switching characteristics of the oscillator and the requirements of the input clock.

表 6-10. Oscillator Switching Characteristics—Crystal Mode

NAME	DESCRIPTION	MIN	TYP	MAX	UNIT
f_p	Oscillation frequency	32.768			kHz
t_{sX}	Start-up time			4	ms

6.1.4.2 RTC Oscillator Input Clock

A 1.8-V LVCMOS-Compatible Clock Input can be used instead of the internal oscillator to provide the FUNC_32K_CLK clock input to the system. The external connections to support this are shown in 图 6-12. The rtc_osc_xi_clk32 pin is connected to the 1.8-V LVCMOS-Compatible clock sources. The rtc_osc_xo pin is left unconnected.



图 6-12. LVCMOS-Compatible Clock Input

表 6-11 summarizes the RTC Oscillator input clock electrical characteristics.

表 6-11. RTC Oscillator Input Clock Electrical Characteristics—Bypass Mode

NAME	DESCRIPTION	MIN	TYP	MAX	UNIT
CK0	$1/t_{c(\text{rtc_osc_xi_clkin32})}$ Frequency, rtc_osc_xi_clkin32	32.768			kHz
CK1	$t_{w(\text{rtc_osc_xi_clkin32})}$ Pulse duration, rtc_osc_xi_clkin32 low or high	0.45 * $t_{c(\text{rtc_osc_xi_clkin32})}$		0.55 * $t_{c(\text{rtc_osc_xi_clkin32})}$	ns
	C_{IN} Input capacitance	2.178	2.378	2.578	pF
	I_{IN} Input current (3.3V mode)	4	6	10	μA
	t_{sX} Start-up time	See (1)			ms

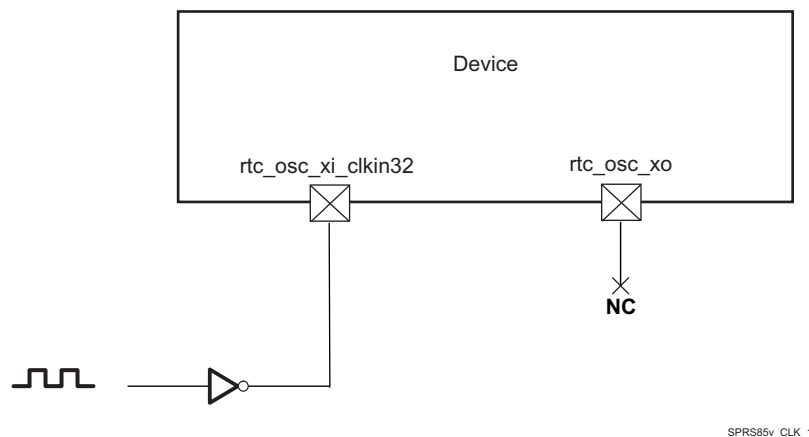
(1) Before the processor boots up and the oscillator is set to bypass mode, there is a waiting time when the internal oscillator is in application mode and receives a wave. The switching time in this case is about 100 μs.



图 6-13. rtc_osc_xi_clkin32 Input Clock

6.2 RC On-die Oscillator Clock

注: The OSC_32K_CLK clock, provided by the On-die 32K RC oscillator, inside of the SoC, is not accurate 32kHz clock.

The frequency may significantly vary with temperature and silicon characteristics.

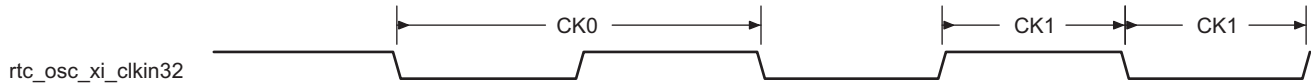
For more information about OSC_32K_CLK see the Device TRM, Chapter: *Power, Reset, and Clock Management*.

6.3 DPLLs, DLLs Specifications

注: For more information, see:

- Power, Reset and Clock Management / Clock Management Functional / Internal Clock Sources / Generators / Generic DPLL Overview Section
and
- Display Subsystem / Display Subsystem Overview section of the Device TRM.

To generate high-frequency clocks, the device supports multiple on-chip DPLLs controlled directly by the PRCM module. They are of two types: type A and type B DPLLs.

- They have their own independent power domain (each one embeds its own switch and can be controlled as an independent functional power domain)
- They are fed with ALWAYS ON system clock, with independent control per DPLL.

The different DPLLs managed by the PRCM are listed below:

- DPLL_MPU: It supplies the MPU subsystem clocking internally.
- DPLL_IVA: It feeds the IVA subsystem clocking.
- DPLL_CORE: It supplies all interface clocks and also few module functional clocks.
- DPLL_PER: It supplies several clock sources: a 192-MHz clock for the display functional clock, a 96-MHz functional clock to subsystems and peripherals.
- DPLL_ABE: It provides clocks to various modules within the device.
- DPLL_USB: It provides 960M clock for USB modules (USB1/2/3/4).
- DPLL_GMAC: It supplies several clocks for the Gigabit Ethernet Switch (GMAC_SW).
- DPLL_EVE: It provides the Embedded Vision Engine Subsystem (EVE1/2/3/4) clocking.
- DPLL_DSP: It feeds the DSP Subsystem clocking.

- DPLL_GPU: It supplies clock for the GPU Subsystem.
- DPLL_DDR: It generates clocks for the two External Memory Interface (EMIF) controllers and their associated EMIF PHYs.
- DPLL_PCIE_REF: It provides reference clock for the APLL_PCIE in PCIE Subsystem.
- APLL_PCIE: It feeds clocks for the device Peripheral Component Interconnect Express (PCIe) controllers.

注: The following DPLLs are controlled by the clock manager located in the always-on Core power domain (CM_CORE_AON):

- DPLL_MPU, DPLL_IVA, DPLL_CORE, DPLL_ABE, DPLL_DDR, DPLL_GMAC, DPLL_PCIE_REF, DPLL_PER, DPLL_USB, DPLL_EVE, DPLL_DSP, DPLL_GPU, APLL_PCIE_REF.
-

For more information on CM_CORE_AON and CM_CORE or PRCM DPLLs, see the Power, Reset, and Clock Management (PRCM) chapter of the Device TRM.

The following DPLLs are not managed by the PRCM:

- DPLL_VIDEO1; (It is controlled from DSS)
- DPLL_VIDEO2; (It is controlled from DSS)
- DPLL_HDMI; (It is controlled from DSS)
- DPLL_SATA; (It is controlled from SATA)
- DPLL_DEBUG; (It is controlled from DEBUGSS)
- DPLL_USB_OTG_SS; (It is controlled from OCP2SCP1)

注: For more information for not controlled from PRCM DPLL's see the related chapters in TRM.

6.3.1 DPLL Characteristics

The DPLL has three relevant input clocks. One of them is the reference clock (CLKINP) used to generated the synthesized clock but can also be used as the bypass clock whenever the DPLL enters a bypass mode. It is therefore mandatory. The second one is a fast bypass clock (CLKINPULOW) used when selected as the bypass clock and is optional. The third clock (CLKINPHIF) is explained in the next paragraph.

The DPLL has three output clocks (namely CLKOUT, CLKOUTX2, and CLKOUTHIF). CLKOUT and CLKOUTX2 run at the bypass frequency whenever the DPLL enters a bypass mode. Both of them are generated from the lock frequency divided by a post-divider (namely M2 post-divider). The third clock, CLKOUTHIF, has no automatic bypass capability. It is an output of a post-divider (M3 post-divider) with the input clock selectable between the internal lock clock (FdpII) and CLKINPHIF input of the PLL through an asynchronous multiplexing.

For more information, see the Power Reset Controller Management chapter of the Device TRM.

表 6-12 summarizes DPLL type described in 6.3, *DPLLs, DLLs Specifications* introduction.

表 6-12. DPLL Control Type

DPLL NAME	TYPE	CONTROLLED BY PRCM
DPLL_ABE	表 6-13 (Type A)	Yes ⁽¹⁾
DPLL_CORE	表 6-13 (Type A)	Yes ⁽¹⁾
DPLL_DEBUGSS	表 6-13 (Type A)	No ⁽²⁾
DPLL_DSP	表 6-13 (Type A)	Yes ⁽¹⁾

表 6-12. DPLL Control Type (continued)

DPLL NAME	TYPE	CONTROLLED BY PRCM
DPLL_EVE	表 6-13 (Type A)	Yes ⁽¹⁾
DPLL_GMAC	表 6-13 (Type A)	Yes ⁽¹⁾
DPLL_HDMI	表 6-14 (Type B)	No ⁽²⁾
DPLL_IVA	表 6-13 (Type A)	Yes ⁽¹⁾
DPLL_MPU	表 6-13 (Type A)	Yes ⁽¹⁾
DPLL_PER	表 6-13 (Type A)	Yes ⁽¹⁾
APLL_PCIE	表 6-13 (Type A)	Yes ⁽¹⁾
DPLL_PCIE_REF	表 6-14 (Type B)	Yes ⁽¹⁾
DPLL_SATA	表 6-14 (Type B)	No ⁽²⁾
DPLL_USB	表 6-14 (Type B)	Yes ⁽¹⁾
DPLL_USB_OTG_SS	表 6-14 (Type B)	No ⁽²⁾
DPLL_VIDEO1	表 6-13 (Type A)	No ⁽²⁾
DPLL_VIDEO2	表 6-13 (Type A)	No ⁽²⁾
DPLL_DDR	表 6-13 (Type A)	Yes ⁽¹⁾
DPLL_GPU	表 6-13 (Type A)	Yes ⁽¹⁾

(1) DPLL is in the always-on domain.

(2) DPLL is not controlled by the PRCM.

表 6-13 和 表 6-14 summarize the DPLL characteristics and assume testing over recommended operating conditions.

表 6-13. DPLL Type A Characteristics

NAME	DESCRIPTION	MIN	TYP	MAX	UNIT	COMMENTS
f_{input}	CLKINP input frequency	0.032		52	MHz	F_{INP}
$f_{internal}$	Internal reference frequency	0.15		52	MHz	REFCLK
$f_{CLKINPHIF}$	CLKINPHIF input frequency	10		1400	MHz	F_{INPHIF}
$f_{CLKINPULOW}$	CLKINPULOW input frequency	0.001		600	MHz	Bypass mode: $f_{CLKOUT} = f_{CLKINPULOW} / (M1 + 1)$ if ulowclken = 1 ⁽⁶⁾
f_{CLKOUT}	CLKOUT output frequency	20 ⁽¹⁾		1800 ⁽²⁾	MHz	$[M / (N + 1)] \times F_{INP} \times [1 / M2]$ (in locked condition)
$f_{CLKOUTx2}$	CLKOUTx2 output frequency	40 ⁽¹⁾		2200 ⁽²⁾	MHz	$2 \times [M / (N + 1)] \times F_{INP} \times [1 / M2]$ (in locked condition)
$f_{CLKOUTHIF}$	CLKOUTHIF output frequency	20 ⁽³⁾		1400 ⁽⁴⁾	MHz	$F_{INPHIF} / M3$ if clkiphifsel = 1
		40 ⁽³⁾		2200 ⁽⁴⁾	MHz	$2 \times [M / (N + 1)] \times F_{INP} \times [1 / M3]$ if clkiphifsel = 0
$f_{CLKDCOLDO}$	DCOCLKLDO output frequency	40		2800	MHz	$2 \times [M / (N + 1)] \times F_{INP}$ (in locked condition)
t_{lock}	Frequency lock time			6 + 350 × REFCLK	μs	
p_{lock}	Phase lock time			6 + 500 × REFCLK	μs	
$t_{relock-L}$	Relock time—Frequency lock ⁽⁵⁾ (LP relock time from bypass)			6 + 70 × REFCLK	μs	DPLL in LP relock time: lowcurrstdby = 1
$p_{relock-L}$	Relock time—Phase lock ⁽⁵⁾ (LP relock time from bypass)			6 + 120 × REFCLK	μs	DPLL in LP relock time: lowcurrstdby = 1
$t_{relock-F}$	Relock time—Frequency lock ⁽⁵⁾ (fast relock time from bypass)			3.55 + 70 × REFCLK	μs	DPLL in fast relock time: lowcurrstdby = 0
$p_{relock-F}$	Relock time—Phase lock ⁽⁵⁾ (fast relock time from bypass)			3.55 + 120 × REFCLK	μs	DPLL in fast relock time: lowcurrstdby = 0

- (1) The minimum frequencies on CLKOUT and CLKOUTX2 are assuming M2 = 1.
For M2 > 1, the minimum frequency on these clocks will further scale down by factor of M2.
- (2) The maximum frequencies on CLKOUT and CLKOUTX2 are assuming M2 = 1.
- (3) The minimum frequency on CLKOUTHIF is assuming M3 = 1. For M3 > 1, the minimum frequency on this clock will further scale down by factor of M3.
- (4) The maximum frequency on CLKOUTHIF is assuming M3 = 1.
- (5) Relock time assumes typical operating conditions, 10°C maximum temperature drift.
- (6) Bypass mode: $f_{\text{CLKOUT}} = F_{\text{INP}}$ if ulowclken = 0. For more information, see the Device TRM.

表 6-14. DPLL Type B Characteristics

NAME	DESCRIPTION	MIN	TYP	MAX	UNIT	COMMENTS
f_{input}	CLKINP input clock frequency	0.62		60	MHz	F_{INP}
f_{internal}	REFCLK internal reference clock frequency	0.62		2.5	MHz	$[1 / (N + 1)] \times F_{\text{INP}}$
$f_{\text{CLKINPULOW}}$	CLKINPULOW bypass input clock frequency	0.001		600	MHz	Bypass mode: $f_{\text{CLKOUT}} = f_{\text{CLKINPULOW}} / (M1 + 1)$ if ulowclken = 1 ⁽⁴⁾
$f_{\text{CLKLDOOUT}}$	CLKOUTLDO output clock frequency	20 ⁽¹⁾⁽⁵⁾		2500 ⁽²⁾⁽⁵⁾	MHz	$M / (N + 1) \times F_{\text{INP}} \times [1 / M2]$ (in locked condition)
f_{CLKOUT}	CLKOUT output clock frequency	20 ⁽¹⁾⁽⁵⁾		1450 ⁽²⁾⁽⁵⁾	MHz	$[M / (N + 1)] \times F_{\text{INP}} \times [1 / M2]$ (in locked condition)
$f_{\text{CLKDCOLDO}}$	Internal oscillator (DCO) output clock frequency	750 ⁽⁵⁾		1500 ⁽⁵⁾	MHz	$[M / (N + 1)] \times F_{\text{INP}}$ (in locked condition)
		1250 ⁽⁵⁾		2500 ⁽⁵⁾	MHz	
t_{j}	CLKOUTLDO period jitter	-2.5%		2.5%		The period jitter at the output clocks is $\pm 2.5\%$ peak to peak
	CLKOUT period jitter					
	CLKDCOLDO period jitter					
t_{lock}	Frequency lock time			350 × REFCLKs	μs	
p_{lock}	Phase lock time			500 × REFCLKs	μs	
$t_{\text{relock-L}}$	Relock time—Frequency lock ⁽³⁾ (LP relock time from bypass)			9 + 30 × REFCLKs	μs	
$p_{\text{relock-L}}$	Relock time—Phase lock ⁽³⁾ (LP relock time from bypass)			9 + 125 × REFCLKs	μs	

- (1) The minimum frequency on CLKOUT is assuming M2 = 1.
For M2 > 1, the minimum frequency on this clock will further scale down by factor of M2.
- (2) The maximum frequency on CLKOUT is assuming M2 = 1.
- (3) Relock time assumes typical operating conditions, 10°C maximum temperature drift.
- (4) Bypass mode: $f_{\text{CLKOUT}} = F_{\text{INP}}$ if ULOWCLKEN = 0. For more information, see the Device TRM.
- (5) For output clocks, there are two frequency ranges according to the SELFREQDCO setting. For more information, see the Device TRM.

6.3.2 DLL Characteristics

表 6-15 summarizes the DLL characteristics and assumes testing over recommended operating conditions.

表 6-15. DLL Characteristics

NAME	DESCRIPTION	MIN	TYP	MAX	UNIT
f_{input}	Input clock frequency (EMIF_DLL_FCLK)			266	MHz
t_{lock}	Lock time			50k	cycles
t_{relock}	Relock time (a change of the DLL frequency implies that DLL must relock)			50k	cycles

6.3.3 DPLL and DLL Noise Isolation

注: For more information on DPLL and DLL decoupling capacitor requirements, see the External Capacitors / Voltage Decoupling Capacitors / I/O and Analog Voltage Decoupling / VDDA Power Domain section.

7 Timing Requirements and Switching Characteristics

7.1 Timing Test Conditions

All timing requirements and switching characteristics are valid over the recommended operating conditions unless otherwise specified.

7.2 Interface Clock Specifications

7.2.1 Interface Clock Terminology

The interface clock is used at the system level to sequence the data and/or to control transfers accordingly with the interface protocol.

7.2.2 Interface Clock Frequency

The two interface clock characteristics are:

- The maximum clock frequency
- The maximum operating frequency

The interface clock frequency documented in this document is the maximum clock frequency, which corresponds to the maximum frequency programmable on this output clock. This frequency defines the maximum limit supported by the Device IC and does not take into account any system consideration (PCB, peripherals).

The system designer will have to consider these system considerations and the Device IC timing characteristics as well to define properly the maximum operating frequency that corresponds to the maximum frequency supported to transfer the data on this interface.

7.3 Timing Parameters and Information

The timing parameter symbols used in the timing requirement and switching characteristic tables are created in accordance with JEDEC Standard 100. To shorten the symbols, some of pin names and other related terminologies have been abbreviated as follows:

表 7-1. Timing Parameters

SUBSCRIPTS	
SYMBOL	PARAMETER
c	Cycle time (period)
d	Delay time
dis	Disable time
en	Enable time
h	Hold time
su	Setup time
START	Start bit
t	Transition time
v	Valid time
w	Pulse duration (width)
X	Unknown, changing, or don't care level
F	Fall time
H	High
L	Low
R	Rise time
V	Valid
IV	Invalid

表 7-1. Timing Parameters (continued)

SUBSCRIPTS	
SYMBOL	PARAMETER
AE	Active Edge
FE	First Edge
LE	Last Edge
Z	High impedance

7.3.1 Parameter Information

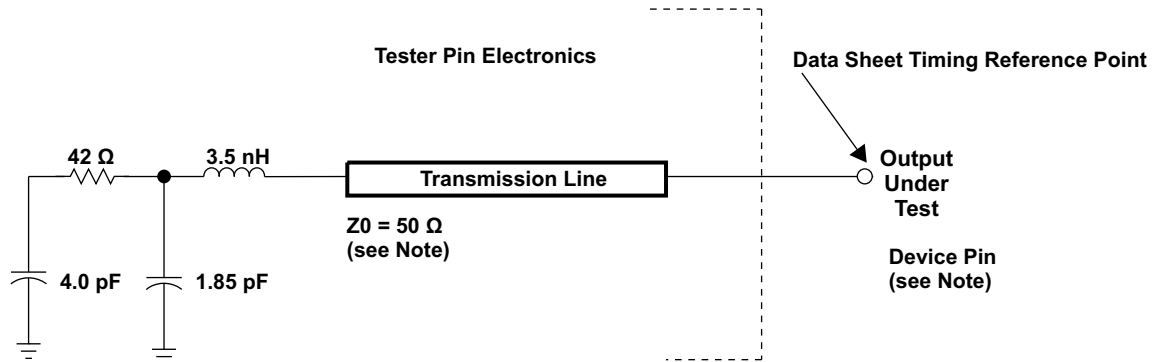

NOTE: The data sheet provides timing at the device pin. For output timing analysis, the tester pin electronics and its transmission line effects must be taken into account. A transmission line with a delay of 2 ns can be used to produce the desired transmission line effect. The transmission line is intended as a load only. It is not necessary to add or subtract the transmission line delay (2 ns) from the data sheet timings.

Input requirements in this data sheet are tested with an input slew rate of < 4 Volts per nanosecond (4 V/ns) at the device pin.

pm_tstcirc_prs403

图 7-1. Test Load Circuit for AC Timing Measurements

The load capacitance value stated is only for characterization and measurement of AC timing signals. This load capacitance value does not indicate the maximum load the device is capable of driving.

7.3.1.1 1.8V and 3.3V Signal Transition Levels

All input and output timing parameters are referenced to V_{ref} for both "0" and "1" logic levels. $V_{ref} = (V_{DD} I/O)/2$.

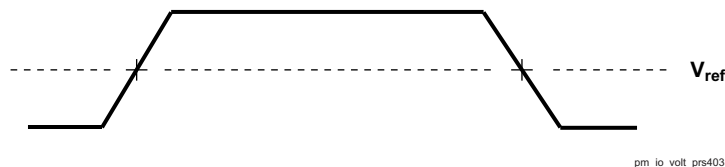

pm_io_volt_prs403

图 7-2. Input and Output Voltage Reference Levels for AC Timing Measurements

All rise and fall transition timing parameters are referenced to $V_{IL} MAX$ and $V_{IH} MIN$ for input clocks, $V_{OL} MAX$ and $V_{OH} MIN$ for output clocks.



图 7-3. Rise and Fall Transition Time Voltage Reference Levels

7.3.1.2 1.8V and 3.3V Signal Transition Rates

The default SLEWCONTROL settings in each pad configuration register must be used to ensure timings, unless specific instructions otherwise are given in the individual timing sub-sections of the datasheet.

All timings are tested with an input edge rate of 4 volts per nanosecond (4 V/ns).

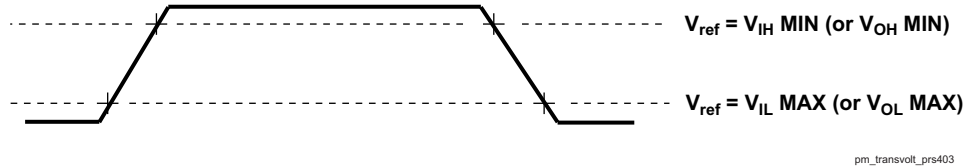
7.3.1.3 Timing Parameters and Board Routing Analysis

The timing parameter values specified in this data manual do not include delays by board routes. As a good board design practice, such delays must always be taken into account. Timing values may be adjusted by increasing/decreasing such delays. TI recommends using the available I/O buffer information specification (IBIS) models to analyze the timing characteristics correctly. To properly use IBIS models to attain accurate timing analysis for a given system, see the *Using IBIS Models for timing Analysis* application report (literature number [SPRA839](#)). If needed, external logic hardware such as buffers may be used to compensate any timing differences.

7.4 Recommended Clock and Control Signal Transition Behavior

All clocks and control signals must transition between V_{IH} and V_{IL} (or between V_{IL} and V_{IH}) in a monotonic manner. Monotonic transitions are more easily ensured with faster switching signals. Slower input transitions are more susceptible to glitches due to noise and special care should be taken for slow input clocks.

7.5 Virtual and Manual I/O Timing Modes

Some of the timings described in the following sections require the use of Virtual or Manual I/O Timing Modes. 表 7-2 provides a summary of the Virtual and Manual I/O Timing Modes across all device interfaces. The individual interface timing sections found later in this document provide the full description of each applicable Virtual and Manual I/O Timing Mode. Refer to the "Pad Configuration" section of the TRM for the procedure on implementing the Virtual and Manual Timing Modes in a system.

表 7-2. Modes Summary

Virtual or Manual IO Mode Name	Data Manual Timing Mode
VIP	
VIP1_MANUAL1	VIN1A/1B/2A Rise-Edge Capture Mode Timings
VIP1_2B_MANUAL1	VIN2B Rise-Edge Capture Mode Timings
VIP1_MANUAL2	VIN1A/1B/2A Fall-Edge Capture Mode Timings
VIP1_2B_MANUAL2	VIN2B Fall-Edge Capture Mode Timings
VIP2_MANUAL1	VIN3A, VIN3B IOSET1 Rise-Edge Capture Mode Timings
VIP2_4A_MANUAL1	VIN4A IOSET1/2 Rise-Edge Capture Mode Timings
VIP2_4A_IOSET3_MANUAL1	VIN4A IOSET3 Rise-Edge Capture Mode Timings
VIP2_4B_MANUAL1	VIN4B Rise-Edge Capture Mode Timings
VIP2_3B_IOSET2_MANUAL1	VIN3B IOSET2 Rise-Edge Capture Mode Timings
VIP2_3B_IOSET2_MANUAL2	VIN3B IOSET2 Fall-Edge Capture Mode Timings
VIP2_MANUAL2	VIN3A, VIN3B IOSET1, VIN4A IOSET1/2 Fall-Edge Capture Mode Timings
VIP2_4A_MANUAL2	VIN4A IOSET1/2 Fall-Edge Capture Mode Timings
VIP2_4A_IOSET3_MANUAL2	VIN4A IOSET3 Fall-Edge Capture Mode Timings

表 7-2. Modes Summary (continued)

Virtual or Manual IO Mode Name	Data Manual Timing Mode
VIP2_4B_MANUAL2	VIN4B Fall-Edge Capture Mode Timings
VIP3_MANUAL1	VIN5A and VIN6A Rise-Edge Capture Mode Timings
VIP3_MANUAL2	VIN5A and VIN6A Fall-Edge Capture Mode Timings
DPI Video Output	
VOUT1_MANUAL1	DPI1 Video Output Alternate Timings
VOUT1_MANUAL2	DPI1 Video Output Default Timings
VOUT1_MANUAL3	DPI1 Video Output MANUAL3 Timings
VOUT1_MANUAL4	DPI1 Video Output MANUAL4 Timings
VOUT2_IOSET1_MANUAL1	DPI2 Video Output IOSET1 Alternate Timings
VOUT2_IOSET1_MANUAL2	DPI2 Video Output IOSET1 Default Timings
VOUT2_IOSET1_MANUAL3	DPI2 Video Output IOSET1 MANUAL3 Timings
VOUT2_IOSET1_MANUAL4	DPI2 Video Output IOSET1 MANUAL4 Timings
VOUT2_IOSET2_MANUAL1	DPI2 Video Output IOSET2 Alternate Timings
VOUT2_IOSET2_MANUAL2	DPI2 Video Output IOSET2 Default Timings
VOUT2_IOSET2_MANUAL3	DPI2 Video Output IOSET2 MANUAL3 Timings
VOUT2_IOSET2_MANUAL4	DPI2 Video Output IOSET2 MANUAL4 Timings
VOUT3_MANUAL1	DPI3 Video Output Alternate Timings
VOUT3_MANUAL2	DPI3 Video Output Default Timings
VOUT3_MANUAL3	DPI3 Video Output MANUAL3 Timings
VOUT3_MANUAL4	DPI3 Video Output MANUAL4 Timings
HDMI, EMIF, Timers, I2C, HDQ/1-Wire, UART, McSPI, USB, SATA, PCIe, DCAN, GPIO, KBD, PWM, ATL, JTAG, TPIU, RTC, SDMA, INTC	
No Virtual or Manual IO Timing Mode Required	All Modes
GPMC	
No Virtual or Manual IO Timing Mode Required	GPMC Asynchronous Mode Timings and Synchronous Mode - Default Timings
GPMC_VIRTUAL1	GPMC Synchronous Mode - Alternate Timings
QSPI	
No Virtual or Manual IO Timing Mode Required	QSPI Mode 3 Default Timing Mode
QSPI_MODE0_MANUAL1	QSPI Mode 0 Default Timing Mode
McASP	
No Virtual or Manual IO Timing Mode Required	McASP1 Synchronous Transmit Timings
MCASP1_VIRTUAL1_ASYNC_TX	See 表 7-55
MCASP1_VIRTUAL2_SYNC_RX	See 表 7-55
MCASP1_VIRTUAL3_ASYNC_RX	See 表 7-55
No Virtual or Manual IO Timing Mode Required	McASP2 Synchronous Transmit Timings
MCASP2_VIRTUAL1_ASYNC_RX_80M	See 表 7-56
MCASP2_VIRTUAL2_ASYNC_RX	See 表 7-56
MCASP2_VIRTUAL3_ASYNC_TX	See 表 7-56
MCASP2_VIRTUAL4_SYNC_RX	See 表 7-56
MCASP2_VIRTUAL5_SYNC_RX_80M	See 表 7-56
No Virtual or Manual IO Timing Mode Required	McASP3 Synchronous Transmit Timings
MCASP3_VIRTUAL2_SYNC_RX	See 表 7-57

表 7-2. Modes Summary (continued)

Virtual or Manual IO Mode Name	Data Manual Timing Mode
No Virtual or Manual IO Timing Mode Required	McASP4 Synchronous Transmit Timings
MCASP4_VIRTUAL1_SYNC_RX	See 表 7-58
No Virtual or Manual IO Timing Mode Required	McASP5 Synchronous Transmit Timings
MCASP5_VIRTUAL1_SYNC_RX	See 表 7-59
No Virtual or Manual IO Timing Mode Required	McASP6 Synchronous Transmit Timings
MCASP6_VIRTUAL1_SYNC_RX	See 表 7-60
No Virtual or Manual IO Timing Mode Required	McASP7 Synchronous Transmit Timings
MCASP7_VIRTUAL2_SYNC_RX	See 表 7-61
No Virtual or Manual IO Timing Mode Required	McASP8 Synchronous Transmit Timings
MCASP8_VIRTUAL1_SYNC_RX	See 表 7-62
GMAC	
No Virtual or Manual IO Timing Mode Required	GMAC MII1/2 Timings
GMAC_RMII0_MANUAL1	GMAC RMII0 Timings
GMAC_RMII1_MANUAL1	GMAC RMII1 Timings
GMAC_RGMII0_MANUAL1	GMAC RGMII0 Internal Delay Enabled Timings Mode
GMAC_RGMII1_MANUAL1	GMAC RGMII1 Internal Delay Enabled Timings Mode
MLB	
MLB_MANUAL1	MLB 3-Pin and 6-Pin Timings
eMMC/SD/SDIO	
No Virtual or Manual IO Timing Mode Required	MMC1 DS (Pad Loopback) and SDR12 (Pad Loopback) Timings
MMC1_VIRTUAL1	MMC1 HS (Internal Loopback and Pad Loopback), SDR12 (Internal Loopback), SDR25 Timings (Internal Loopback and Pad Loopback)
MMC1_VIRTUAL2	SDR50 (Pad Loopback) Timings
MMC1_VIRTUAL5	MMC1 DS (Internal Loopback) Timings
MMC1_VIRTUAL6	MMC1 SDR50 (Internal Loopback) Timings
MMC1_VIRTUAL7	MMC1 DDR50 (Internal Loopback) Timings
MMC1_DDR_MANUAL1	MMC1 DDR50 (Pad Loopback) Timings
MMC1_SDR104_MANUAL1	MMC1 SDR104 Timings
No Virtual or Manual IO Timing Mode Required	MMC2 Standard (Pad Loopback), High Speed (Pad Loopback), and DDR (Pad Loopback) Timings
MMC2_DDR_LB_MANUAL1	MMC2 DDR (Internal Loopback) Timings
MMC2_HS200_MANUAL1	MMC2 HS200 Timings
MMC2_STD_HS_LB_MANUAL1	MMC2 Standard (Internal Loopback), High Speed (Internal Loopback) Timings
MMC3_MANUAL1	MMC3 DS, SDR12, HS, SDR25 Timings, SDR50 Timings
MMC4_MANUAL1	MMC4 SDR12, HS, SDR25 Timings
MMC4_DS_MANUAL1	MMC4 DS Timings

7.6 Video Input Ports (VIP)

The Device includes 3 Video Input Ports (VIP).

表 7-3, 图 7-4 和 图 7-5 呈现 timings 和 switching characteristics of the VIPs.

注意

The IO timings provided in this section are applicable for all combinations of signals for vin1, vin5 and vin6. However, the timings are only valid for vin2, vin3, and vin4 if signals within a single IOSET are used. The IOSETs are defined in the 表 7-4, 表 7-5 和 表 7-6.

表 7-3. Timing Requirements for VIP ⁽¹⁾⁽²⁾

NO.	PARAMETER	DESCRIPTION	MODE	MIN	MAX	UNIT
V1	$t_c(\text{CLK})$	Cycle time, vinx_clki ^{(3) (5)}		6.06 ⁽¹⁾		ns
V2	$t_w(\text{CLKH})$	Pulse duration, vinx_clki high ^{(3) (5)}		$0.45 \cdot P$ ⁽²⁾		ns
V3	$t_w(\text{CLKL})$	Pulse duration, vinx_clki low ^{(3) (5)}		$0.45 \cdot P$ ⁽²⁾		ns
V4	$t_{su}(\text{CTL/DATA-CLK})$	Input setup time, Control (vinx_dei, vinx_vsynci, vinx_fldi, vinx_hsynci) and Data (vinx_dn) valid to vinx_clki transition ^{(3) (4) (5)}	vin1x, vin2x	2.93		ns
			vin5x, vin6x	3.11		ns
			vin3x, vin4x	3.11		ns
V5	$t_h(\text{CLK-CTL/DATA})$	Input hold time, Control (vinx_dei, vinx_vsynci, vinx_fldi, vinx_hsynci) and Data (vinx_dn) valid from vinx_clki transition ^{(3) (4) (5)}		-0.05		ns

(1) For maximum frequency of 165 MHz.

(2) $P = \text{vinx_clki}$ period.

(3) x in vinx = 1a, 1b, 2a, 2b, 3a, 3b, 4a, 4b, 5a and 6a.

(4) n in dn = 0 to 7 when x = 1b, 2b, 3b and 4b;

n = 0 to 15 when x = 5a and 6a;

n = 0 to 23 when x = 1a, 2a, 3a and 4a;

(5) i in clki, dei, vsynci, hsynci and fldi = 0 or 1.

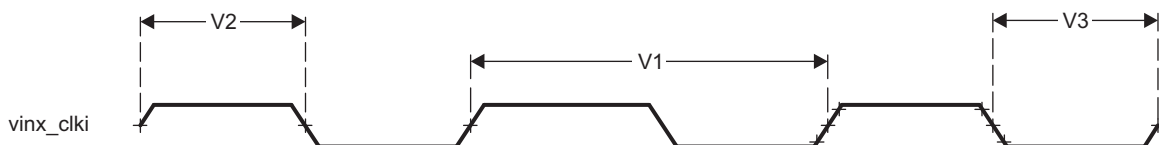

SPRS8xx_VIP_01

图 7-4. Video Input Ports clock signal

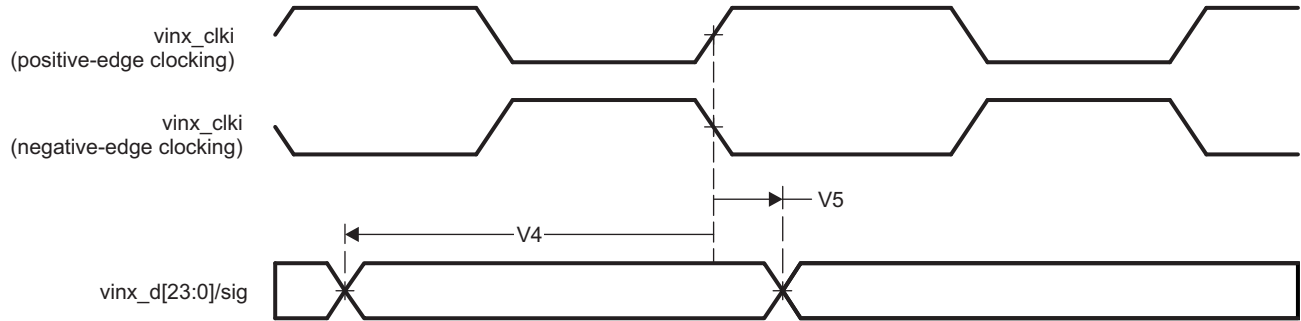

SPRS8xx_VIP_02

图 7-5. Video Input Ports timings

In 表 7-4, 表 7-5 and 表 7-6 are presented the specific groupings of signals (IOSET) for use with vin2, vin3, and vin4.

表 7-4. VIN2 IOSETs

Signals	IOSET1		IOSET2		IOSET3	
	BALL	MUX	BALL	MUX	BALL	MUX
vin2a						
vin2a_d0	F2	0	F2	0	U4	4
vin2a_d1	F3	0	F3	0	V2	4
vin2a_d2	D1	0	D1	0	Y1	4
vin2a_d3	E2	0	E2	0	W9	4
vin2a_d4	D2	0	D2	0	V9	4
vin2a_d5	F4	0	F4	0	U5	4
vin2a_d6	C1	0	C1	0	V5	4
vin2a_d7	E4	0	E4	0	V4	4
vin2a_d8	F5	0	F5	0	V3	4
vin2a_d9	E6	0	E6	0	Y2	4
vin2a_d10	D3	0	D3	0	U6	4
vin2a_d11	F6	0	F6	0	U3	4
vin2a_d12	D5	0	D5	0	-	-
vin2a_d13	C2	0	C2	0	-	-
vin2a_d14	C3	0	C3	0	-	-
vin2a_d15	C4	0	C4	0	-	-
vin2a_d16	B2	0	B2	0	-	-
vin2a_d17	D6	0	D6	0	-	-
vin2a_d18	C5	0	C5	0	-	-
vin2a_d19	A3	0	A3	0	-	-
vin2a_d20	B3	0	B3	0	-	-
vin2a_d21	B4	0	B4	0	-	-
vin2a_d22	B5	0	B5	0	-	-
vin2a_d23	A4	0	A4	0	-	-
vin2a_hsync0	G1	0	G1	0	U7	4
vin2a_vsync0	G6	0	G6	0	V6	4
vin2a_de0	G2	0	-	-	V7	4
vin2a_fld0	H7	0	G2	1	W2	4
vin2a_clk0	E1	0	E1	0	V1	4
vin2b						

表 7-4. VIN2 IOSETs (continued)

Signals	IOSET1		IOSET2		IOSET3	
	BALL	MUX	BALL	MUX	BALL	MUX
vin2b_clk1	H7	2	H7	2	AB5	4
vin2b_de1	-	-	G2	3	AB8	4
vin2b_fld1	G2	2	-	-	-	-
vin2b_d0	A4	2	A4	2	AD6	4
vin2b_d1	B5	2	B5	2	AC8	4
vin2b_d2	B4	2	B4	2	AC3	4
vin2b_d3	B3	2	B3	2	AC9	4
vin2b_d4	A3	2	A3	2	AC6	4
vin2b_d5	C5	2	C5	2	AC7	4
vin2b_d6	D6	2	D6	2	AC4	4
vin2b_d7	B2	2	B2	2	AD4	4
vin2b_hsync1	G1	3	G1	3	AC5	4
vin2b_vsync1	G6	3	G6	3	AB4	4

表 7-5. VIN3 IOSETs

Signals	IOSET1		IOSET2		IOSET3		IOSET4	
	BALL	MUX	BALL	MUX	BALL	MUX	BALL	MUX
vin3a								
vin3a_d0	M6	2	AF1	6	AF1	6	B7	4
vin3a_d1	M2	2	AE3	6	AE3	6	B8	4
vin3a_d2	L5	2	AE5	6	AE5	6	A7	4
vin3a_d3	M1	2	AE1	6	AE1	6	A8	4
vin3a_d4	L6	2	AE2	6	AE2	6	C9	4
vin3a_d5	L4	2	AE6	6	AE6	6	A9	4
vin3a_d6	L3	2	AD2	6	AD2	6	B9	4
vin3a_d7	L2	2	AD3	6	AD3	6	A10	4
vin3a_d8	L1	2	B2	6	B2	6	E8	4
vin3a_d9	K2	2	D6	6	D6	6	D9	4
vin3a_d10	J1	2	C5	6	C5	6	D7	4
vin3a_d11	J2	2	A3	6	A3	6	D8	4
vin3a_d12	H1	2	B3	6	-	-	A5	4
vin3a_d13	J3	2	B4	6	-	-	C6	4
vin3a_d14	H2	2	B5	6	-	-	C8	4
vin3a_d15	H3	2	A4	6	-	-	C7	4
vin3a_d16	R6	2	-	-	-	-	F11	4
vin3a_d17	T9	2	-	-	-	-	G10	4
vin3a_d18	T6	2	-	-	-	-	F10	4
vin3a_d19	T7	2	-	-	-	-	G11	4
vin3a_d20	P6	2	-	-	-	-	E9	4
vin3a_d21	R9	2	-	-	-	-	F9	4
vin3a_d22	R5	2	-	-	-	-	F8	4
vin3a_d23	P5	2	-	-	-	-	E7	4
vin3a_hsync0	N7	2	N7	2	B5	5	C11	4
vin3a_vsync0	R4	2	R4	2	A4	5	E11	4
vin3a_de0	N9	2	N9	2	B3	5	B10	4
vin3a_fld0	P9	2	P9	2	B4	5	D11	4

表 7-5. VIN3 IOSETs (continued)

Signals	IOSET1		IOSET2		IOSET3		IOSET4	
	BALL	MUX	BALL	MUX	BALL	MUX	BALL	MUX
vin3a_clk0	P1	2	AH7	6	AH7	6	B11	4
vin3b								
vin3b_clk1	P7	6	M4	4	-	-	-	-
vin3b_de1	N6	6	N6	6	-	-	-	-
vin3b_fld1	M4	6	-	-	-	-	-	-
vin3b_d0	K7	6	K7	6	-	-	-	-
vin3b_d1	M7	6	M7	6	-	-	-	-
vin3b_d2	J5	6	J5	6	-	-	-	-
vin3b_d3	K6	6	K6	6	-	-	-	-
vin3b_d4	J7	6	J7	6	-	-	-	-
vin3b_d5	J4	6	J4	6	-	-	-	-
vin3b_d6	J6	6	J6	6	-	-	-	-
vin3b_d7	H4	6	H4	6	-	-	-	-
vin3b_hsync1	H5	6	H5	6	-	-	-	-
vin3b_vsync1	H6	6	H6	6	-	-	-	-

表 7-6. VIN4 IOSETs

Signals	IOSET1		IOSET2		IOSET3	
	BALL	MUX	BALL	MUX	BALL	MUX
vin4a						
vin4a_d0	R6	4	B7	3	B14	8
vin4a_d1	T9	4	B8	3	J14	8
vin4a_d2	T6	4	A7	3	G13	8
vin4a_d3	T7	4	A8	3	J11	8
vin4a_d4	P6	4	C9	3	E12	8
vin4a_d5	R9	4	A9	3	F13	8
vin4a_d6	R5	4	B9	3	C12	8
vin4a_d7	P5	4	A10	3	D12	8
vin4a_d8	U2	4	E8	3	E15	8
vin4a_d9	U1	4	D9	3	A20	8
vin4a_d10	P3	4	D7	3	B15	8
vin4a_d11	R2	4	D8	3	A15	8
vin4a_d12	K7	4	A5	3	D15	8
vin4a_d13	M7	4	C6	3	B16	8
vin4a_d14	J5	4	C8	3	B17	8
vin4a_d15	K6	4	C7	3	A17	8
vin4a_d16	-	-	F11	3	C18	8
vin4a_d17	-	-	G10	3	A21	8
vin4a_d18	-	-	F10	3	G16	8
vin4a_d19	-	-	G11	3	D17	8
vin4a_d20	-	-	E9	3	AA3	8
vin4a_d21	-	-	F9	3	AB9	8
vin4a_d22	-	-	F8	3	AB3	8
vin4a_d23	-	-	E7	3	AA4	8
vin4a_hsync0	R3/ P7	4 / 4	C11	3	E21	8
vin4a_vsync0	T2/ N1	4 / 4	E11	3	F20	8

表 7-6. VIN4 IOSETs (continued)

Signals	IOSET1		IOSET2		IOSET3	
	BALL	MUX	BALL	MUX	BALL	MUX
vin4a_de0	H6/ P7	4 / 5	B10	3	C23	8
vin4a_fld0	P9/ J7	4 / 4	D11	3	F21	8
vin4a_clk0	P4	4	B11	3	B26	8
vin4b						
vin4b_clk1	N9	6	V1	5	-	-
vin4b_de1	P9	6	V7	5	-	-
vin4b_fld1	P4	6	W2	5	-	-
vin4b_d0	R6	6	U4	5	-	-
vin4b_d1	T9	6	V2	5	-	-
vin4b_d2	T6	6	Y1	5	-	-
vin4b_d3	T7	6	W9	5	-	-
vin4b_d4	P6	6	V9	5	-	-
vin4b_d5	R9	6	U5	5	-	-
vin4b_d6	R5	6	V5	5	-	-
vin4b_d7	P5	6	V4	5	-	-
vin4b_hsync1	N7	6	U7	5	-	-
vin4b_ysync1	R4	6	V6	5	-	-

注: To configure the desired Manual IO Timing Mode the user must follow the steps described in section "Manual IO Timing Modes" of the Device TRM.

The associated registers to configure are listed in the **CFG REGISTER** column. For more information please see the *Control Module Chapter* in the Device TRM.

Manual IO Timings Modes must be used to ensure some IO timings for VIP1. See 表 7-2 Modes Summary for a list of IO timings requiring the use of Manual IO Timings Modes. See 表 7-7 Manual Functions Mapping for VIP1 for a definition of the Manual modes.

表 7-7 lists the A_DELAY and G_DELAY values needed to calculate the correct values to be set in the CFG_x registers.

表 7-7. Manual Functions Mapping for VIP1

BALL	BALL NAME	VIP1_MANUAL1		VIP1_MANUAL2		CFG REGISTER	MUXMODE				
		A_DELAY (ps)	G_DELAY (ps)	A_DELAY (ps)	G_DELAY (ps)		0	1	2	3	4
U3	RMII_MHZ_50_CLK	1621	614	2018	279	CFG_RMII_MHZ_50_CLK_IN	-	-	-	-	vin2a_d11
N6	gpmc_ben0	1756	1019	2235	494	CFG_GPMC_BEN0_IN	-	-	-	vin1b_hsync1	-
M4	gpmc_ben1	1684	1107	2198	568	CFG_GPMC_BEN1_IN	-	-	-	vin1b_de1	-
U4	mdio_d	1594	417	2007	36	CFG_MDIO_D_IN	-	-	-	-	vin2a_d0
V1	mdio_mclk	0	0	0	0	CFG_MDIO_MCLK_IN	-	-	-	-	vin2a_clk0
U5	rgmii0_rxc	1005	935	1932	0	CFG_RGMII0_RXC_IN	-	-	-	-	vin2a_d5
V5	rgmii0_rxctl	1579	836	1982	485	CFG_RGMII0_RXCTL_IN	-	-	-	-	vin2a_d6
W2	rgmii0_rxd0	1032	1033	1995	0	CFG_RGMII0_RXD0_IN	-	-	-	-	vin2a_fld0
Y2	rgmii0_rxd1	950	1625	1993	673	CFG_RGMII0_RXD1_IN	-	-	-	-	vin2a_d9
V3	rgmii0_rxd2	1578	832	1973	535	CFG_RGMII0_RXD2_IN	-	-	-	-	vin2a_d8
V4	rgmii0_rxd3	1022	1648	2017	740	CFG_RGMII0_RXD3_IN	-	-	-	-	vin2a_d7
W9	rgmii0_txc	1604	769	2020	393	CFG_RGMII0_TXC_IN	-	-	-	-	vin2a_d3
V9	rgmii0_txctl	1060	1389	2074	396	CFG_RGMII0_TXCTL_IN	-	-	-	-	vin2a_d4
U6	rgmii0_txd0	938	1242	2021	194	CFG_RGMII0_TXD0_IN	-	-	-	-	vin2a_d10
V6	rgmii0_txd1	1013	1679	2036	730	CFG_RGMII0_TXD1_IN	-	-	-	-	vin2a_vsync0
U7	rgmii0_txd2	1524	886	1933	526	CFG_RGMII0_TXD2_IN	-	-	-	-	vin2a_hsync0
V7	rgmii0_txd3	1079	1504	2090	490	CFG_RGMII0_TXD3_IN	-	-	-	-	vin2a_de0
V2	uart3_rxd	1530	125	1586	0	CFG_UART3_RXD_IN	-	-	-	-	vin2a_d1
Y1	uart3_txd	1572	487	1980	16	CFG_UART3_TXD_IN	-	-	-	-	vin2a_d2
AG8	vin1a_clk0	0	0	0	0	CFG_VIN1A_CLK0_IN	vin1a_clk0	-	-	-	-
AE8	vin1a_d0	1697	1087	2105	619	CFG_VIN1A_D0_IN	vin1a_d0	-	-	-	-
AD8	vin1a_d1	1589	1164	2017	757	CFG_VIN1A_D1_IN	vin1a_d1	-	-	-	-
AG3	vin1a_d10	1733	1119	2107	739	CFG_VIN1A_D10_IN	vin1a_d10	vin1b_d5	-	-	-
AG5	vin1a_d11	1563	1210	2005	788	CFG_VIN1A_D11_IN	vin1a_d11	vin1b_d4	-	-	-
AF2	vin1a_d12	1705	1647	2059	1297	CFG_VIN1A_D12_IN	vin1a_d12	vin1b_d3	-	-	-
AF6	vin1a_d13	1624	1525	2027	1141	CFG_VIN1A_D13_IN	vin1a_d13	vin1b_d2	-	-	-
AF3	vin1a_d14	1730	1655	2071	1332	CFG_VIN1A_D14_IN	vin1a_d14	vin1b_d1	-	-	-
AF4	vin1a_d15	1681	2004	1995	1764	CFG_VIN1A_D15_IN	vin1a_d15	vin1b_d0	-	-	-
AF1	vin1a_d16	1659	1813	1999	1542	CFG_VIN1A_D16_IN	vin1a_d16	vin1b_d7	-	-	-
AE3	vin1a_d17	1715	1887	2072	1540	CFG_VIN1A_D17_IN	vin1a_d17	vin1b_d6	-	-	-
AE5	vin1a_d18	1728	1898	2034	1629	CFG_VIN1A_D18_IN	vin1a_d18	vin1b_d5	-	-	-

表 7-7. Manual Functions Mapping for VIP1 (continued)

BALL	BALL NAME	VIP1_MANUAL1		VIP1_MANUAL2		CFG REGISTER	MUXMODE				
		A_DELAY (ps)	G_DELAY (ps)	A_DELAY (ps)	G_DELAY (ps)		0	1	2	3	4
AE1	vin1a_d19	1707	2006	2026	1761	CFG_VIN1A_D19_IN	vin1a_d19	vin1b_d4	-	-	-
AG7	vin1a_d2	1557	1414	1996	962	CFG_VIN1A_D2_IN	vin1a_d2	-	-	-	-
AE2	vin1a_d20	1695	1814	2037	1469	CFG_VIN1A_D20_IN	vin1a_d20	vin1b_d3	-	-	-
AE6	vin1a_d21	1757	1682	2077	1349	CFG_VIN1A_D21_IN	vin1a_d21	vin1b_d2	-	-	-
AD2	vin1a_d22	1683	1813	2022	1545	CFG_VIN1A_D22_IN	vin1a_d22	vin1b_d1	-	-	-
AD3	vin1a_d23	1833	1187	2168	784	CFG_VIN1A_D23_IN	vin1a_d23	vin1b_d0	-	-	-
AH6	vin1a_d3	1588	1289	1993	901	CFG_VIN1A_D3_IN	vin1a_d3	-	-	-	-
AH3	vin1a_d4	1687	949	2098	499	CFG_VIN1A_D4_IN	vin1a_d4	-	-	-	-
AH5	vin1a_d5	1616	1257	2038	844	CFG_VIN1A_D5_IN	vin1a_d5	-	-	-	-
AG6	vin1a_d6	1582	1265	2002	863	CFG_VIN1A_D6_IN	vin1a_d6	-	-	-	-
AH4	vin1a_d7	1659	1255	2063	873	CFG_VIN1A_D7_IN	vin1a_d7	-	-	-	-
AG4	vin1a_d8	1681	1205	2088	759	CFG_VIN1A_D8_IN	vin1a_d8	vin1b_d7	-	-	-
AG2	vin1a_d9	1778	1168	2152	701	CFG_VIN1A_D9_IN	vin1a_d9	vin1b_d6	-	-	-
AD9	vin1a_de0	1468	1290	1926	728	CFG_VIN1A_DE0_IN	vin1a_de0	vin1b_hsync1	-	-	-
AF9	vin1a_fld0	1633	1425	2043	937	CFG_VIN1A_FLD0_IN	vin1a_fld0	vin1b_vsync1	-	-	-
AE9	vin1a_hsync0	1561	1424	1978	909	CFG_VIN1A_HSYNC0_IN	vin1a_hsync0	vin1b_fld1	-	-	-
AF8	vin1a_vsync0	1470	1369	1926	987	CFG_VIN1A_VSYNC0_IN	vin1a_vsync0	vin1b_de1	-	-	-
AH7	vin1b_clk1	69	150	242	0	CFG_VIN1B_CLK1_IN	vin1b_clk1	-	-	-	-
E1	vin2a_clk0	0	0	0	0	CFG_VIN2A_CLK0_IN	vin2a_clk0	-	-	-	-
F2	vin2a_d0	1597	561	2009	147	CFG_VIN2A_D0_IN	vin2a_d0	-	-	-	-
F3	vin2a_d1	1598	801	2015	561	CFG_VIN2A_D1_IN	vin2a_d1	-	-	-	-
D3	vin2a_d10	1576	655	2021	377	CFG_VIN2A_D10_IN	vin2a_d10	-	-	-	-
F6	vin2a_d11	1488	340	1940	19	CFG_VIN2A_D11_IN	vin2a_d11	-	-	-	-
D5	vin2a_d12	1399	612	1895	181	CFG_VIN2A_D12_IN	vin2a_d12	-	-	-	-
C2	vin2a_d13	1595	439	2063	15	CFG_VIN2A_D13_IN	vin2a_d13	-	-	-	-
C3	vin2a_d14	1480	243	1709	0	CFG_VIN2A_D14_IN	vin2a_d14	-	-	-	-
C4	vin2a_d15	1415	755	1899	369	CFG_VIN2A_D15_IN	vin2a_d15	-	-	-	-
B2	vin2a_d16	1341	653	1821	317	CFG_VIN2A_D16_IN	vin2a_d16	-	vin2b_d7	-	-
D6	vin2a_d17	1396	724	1880	349	CFG_VIN2A_D17_IN	vin2a_d17	-	vin2b_d6	-	-
C5	vin2a_d18	1582	364	1963	0	CFG_VIN2A_D18_IN	vin2a_d18	-	vin2b_d5	-	-
A3	vin2a_d19	1308	289	1681	0	CFG_VIN2A_D19_IN	vin2a_d19	-	vin2b_d4	-	-
D1	vin2a_d2	1600	323	2021	0	CFG_VIN2A_D2_IN	vin2a_d2	-	-	-	-

表 7-7. Manual Functions Mapping for VIP1 (continued)

BALL	BALL NAME	VIP1_MANUAL1		VIP1_MANUAL2		CFG REGISTER	MUXMODE				
		A_DELAY (ps)	G_DELAY (ps)	A_DELAY (ps)	G_DELAY (ps)		0	1	2	3	4
B3	vin2a_d20	1307	586	1772	299	CFG_VIN2A_D20_IN	vin2a_d20	-	vin2b_d3	-	-
B4	vin2a_d21	1301	640	1787	282	CFG_VIN2A_D21_IN	vin2a_d21	-	vin2b_d2	-	-
B5	vin2a_d22	1316	534	1789	223	CFG_VIN2A_D22_IN	vin2a_d22	-	vin2b_d1	-	-
A4	vin2a_d23	1311	613	1788	286	CFG_VIN2A_D23_IN	vin2a_d23	-	vin2b_d0	-	-
E2	vin2a_d3	1765	720	2142	492	CFG_VIN2A_D3_IN	vin2a_d3	-	-	-	-
D2	vin2a_d4	1680	282	2071	0	CFG_VIN2A_D4_IN	vin2a_d4	-	-	-	-
F4	vin2a_d5	1791	696	2155	461	CFG_VIN2A_D5_IN	vin2a_d5	-	-	-	-
C1	vin2a_d6	1538	175	1849	0	CFG_VIN2A_D6_IN	vin2a_d6	-	-	-	-
E4	vin2a_d7	1546	451	1977	192	CFG_VIN2A_D7_IN	vin2a_d7	-	-	-	-
F5	vin2a_d8	1522	650	1966	391	CFG_VIN2A_D8_IN	vin2a_d8	-	-	-	-
E6	vin2a_d9	1546	578	1996	270	CFG_VIN2A_D9_IN	vin2a_d9	-	-	-	-
G2	vin2a_de0	1548	623	2036	213	CFG_VIN2A_DE0_IN	vin2a_de0	vin2a_fld0	vin2b_fld1	vin2b_de1	-
H7	vin2a_fld0	1771	815	2162	566	CFG_VIN2A_FLD0_IN	vin2a_fld0	-	vin2b_clk1	-	-
G1	vin2a_hsync0	1703	587	2071	225	CFG_VIN2A_HSYNC0_IN	vin2a_hsync0	-	-	vin2b_hsync1	-
G6	vin2a_vsync0	1486	464	1895	53	CFG_VIN2A_VSYNC0_IN	vin2a_vsync0	-	-	vin2b_vsync1	-

Manual IO Timings Modes must be used to ensure some IO timings for VIP1. See 表 7-2 Modes Summary for a list of IO timings requiring the use of Manual IO Timings Modes. See 表 7-8 Manual Functions Mapping for VIP1 2B for a definition of the Manual modes.

表 7-8 lists the A_DELAY and G_DELAY values needed to calculate the correct values to be set in the CFG_x registers.

表 7-8. Manual Functions Mapping for VIP1 2B

BALL	BALL NAME	VIP1_2B_MANUAL1		VIP1_2B_MANUAL2		CFG REGISTER	MUXMODE		
		A_DELAY (ps)	G_DELAY (ps)	A_DELAY (ps)	G_DELAY (ps)		2	3	4
AC5	gpio6_10	1830	911	2136	593	CFG_GPIO6_10_IN	-	-	vin2b_hsync1
AB4	gpio6_11	1797	1159	2088	926	CFG_GPIO6_11_IN	-	-	vin2b_vsync1
AD4	mmc3_clk	(1)	(1)	(1)	(1)	CFG_MMC3_CLK_IN	-	-	vin2b_d7
AC4	mmc3_cmd	1769	980	2092	650	CFG_MMC3_CMD_IN	-	-	vin2b_d6
AC7	mmc3_dat0	1678	984	2027	691	CFG_MMC3_DAT0_IN	-	-	vin2b_d5
AC6	mmc3_dat1	1664	883	2031	491	CFG_MMC3_DAT1_IN	-	-	vin2b_d4
AC9	mmc3_dat2	1672	439	2065	0	CFG_MMC3_DAT2_IN	-	-	vin2b_d3
AC3	mmc3_dat3	1762	1078	2089	799	CFG_MMC3_DAT3_IN	-	-	vin2b_d2
AC8	mmc3_dat4	1766	583	2125	135	CFG_MMC3_DAT4_IN	-	-	vin2b_d1

表 7-8. Manual Functions Mapping for VIP1 2B (continued)

BALL	BALL NAME	VIP1_2B_MANUAL1		VIP1_2B_MANUAL2		CFG REGISTER	MUXMODE		
		A_DELAY (ps)	G_DELAY (ps)	A_DELAY (ps)	G_DELAY (ps)		2	3	4
AD6	mmc3_dat5	1777	577	2072	362	CFG_MMC3_DAT5_IN	-	-	vin2b_d0
AB8	mmc3_dat6	1675	808	2035	431	CFG_MMC3_DAT6_IN	-	-	vin2b_de1
AB5	mmc3_dat7	0	0	0	0	CFG_MMC3_DAT7_IN	-	-	vin2b_clk1
B2	vin2a_d16	1181	0	1424	0	CFG_VIN2A_D16_IN	vin2b_d7	-	-
D6	vin2a_d17	1317	0	1545	0	CFG_VIN2A_D17_IN	vin2b_d6	-	-
C5	vin2a_d18	1132	0	1240	0	CFG_VIN2A_D18_IN	vin2b_d5	-	-
A3	vin2a_d19	749	0	919	0	CFG_VIN2A_D19_IN	vin2b_d4	-	-
B3	vin2a_d20	1078	0	1320	0	CFG_VIN2A_D20_IN	vin2b_d3	-	-
B4	vin2a_d21	1119	0	1357	0	CFG_VIN2A_D21_IN	vin2b_d2	-	-
B5	vin2a_d22	1089	0	1306	0	CFG_VIN2A_D22_IN	vin2b_d1	-	-
A4	vin2a_d23	1118	0	1362	0	CFG_VIN2A_D23_IN	vin2b_d0	-	-
G2	vin2a_de0	1371	420	1813	86	CFG_VIN2A_DE0_IN	vin2b_fld1	vin2b_de1	-
H7	vin2a_fld0	0	0	0	0	CFG_VIN2A_FLD0_IN	vin2b_clk1	-	-
G1	vin2a_hsync0	1605	0	1674	0	CFG_VIN2A_HSYNC0_IN	-	vin2b_hsync1	-
G6	vin2a_vsync0	1231	0	1300	0	CFG_VIN2A_VSYNC0_IN	-	vin2b_vsync1	-

(1) The CFG_MMC3_CLK_IN register should remain at its Default value, which is programmed automatically by hardware during the recalibration process.

Manual IO Timings Modes must be used to ensure some IO timings for VIP2. See 表 7-2 Modes Summary for a list of IO timings requiring the use of Manual IO Timings Modes. See 表 7-9 Manual Functions Mapping for VIP2 for a definition of the Manual modes.

表 7-9 lists the A_DELAY and G_DELAY values needed to calculate the correct values to be set in the CFG_x registers.

表 7-9. Manual Functions Mapping for VIP2

BALL	BALL NAME	VIP2_MANUAL 1		VIP2_MANUAL2		CFG REGISTER	MUXMODE				
		A_DELAY (ps)	G_DELAY (ps)	A_DELAY (ps)	G_DELAY (ps)		2	3	4	5	6
R6	gpmc_a0	2216	947	2519	702	CFG_GPMC_A0_IN	vin3a_d16	-	vin4a_d0	-	-
T9	gpmc_a1	2078	1022	2384	778	CFG_GPMC_A1_IN	vin3a_d17	-	vin4a_d1	-	-
N9	gpmc_a10	2108	823	2435	411	CFG_GPMC_A10_IN	vin3a_de0	-	-	-	-
P9	gpmc_a11	2068	977	2379	755	CFG_GPMC_A11_IN	vin3a_fld0	-	vin4a_fld0	-	-
K7	gpmc_a19	1740	123	1743	0	CFG_GPMC_A19_IN	-	-	vin4a_d12	-	vin3b_d0
T6	gpmc_a2	2280	1298	2499	1127	CFG_GPMC_A2_IN	vin3a_d18	-	vin4a_d2	-	-
M7	gpmc_a20	1628	30	1529	0	CFG_GPMC_A20_IN	-	-	vin4a_d13	-	vin3b_d1
J5	gpmc_a21	1687	217	1779	0	CFG_GPMC_A21_IN	-	-	vin4a_d14	-	vin3b_d2

表 7-9. Manual Functions Mapping for VIP2 (continued)

BALL	BALL NAME	VIP2_MANUAL 1		VIP2_MANUAL2		CFG REGISTER	MUXMODE				
		A_DELAY (ps)	G_DELAY (ps)	A_DELAY (ps)	G_DELAY (ps)		2	3	4	5	6
K6	gpmc_a22	1595	151	1620	0	CFG_GPMC_A22_IN	-	-	vin4a_d15	-	vin3b_d3
J7	gpmc_a23	1366	0	1363	0	CFG_GPMC_A23_IN	-	-	vin4a_fld0	-	vin3b_d4
J4	gpmc_a24	1554	343	1765	0	CFG_GPMC_A24_IN	-	-	-	-	vin3b_d5
J6	gpmc_a25	1652	268	1808	0	CFG_GPMC_A25_IN	-	-	-	-	vin3b_d6
H4	gpmc_a26	1546	281	1669	0	CFG_GPMC_A26_IN	-	-	-	-	vin3b_d7
H5	gpmc_a27	1534	198	1611	0	CFG_GPMC_A27_IN	-	-	-	-	vin3b_hsync1
T7	gpmc_a3	2246	1318	2455	1181	CFG_GPMC_A3_IN	vin3a_d19	-	vin4a_d3	-	-
P6	gpmc_a4	2266	1216	2486	1039	CFG_GPMC_A4_IN	vin3a_d20	-	vin4a_d4	-	-
R9	gpmc_a5	2185	1122	2456	938	CFG_GPMC_A5_IN	vin3a_d21	-	vin4a_d5	-	-
R5	gpmc_a6	2206	782	2463	573	CFG_GPMC_A6_IN	vin3a_d22	-	vin4a_d6	-	-
P5	gpmc_a7	2369	1025	2608	783	CFG_GPMC_A7_IN	vin3a_d23	-	vin4a_d7	-	-
N7	gpmc_a8	2154	978	2430	656	CFG_GPMC_A8_IN	vin3a_hsync0	-	-	-	-
R4	gpmc_a9	2185	1152	2465	850	CFG_GPMC_A9_IN	vin3a_vsync0	-	-	-	-
M6	gpmc_ad0	1908	620	2316	301	CFG_GPMC_AD0_IN	vin3a_d0	-	-	-	-
M2	gpmc_ad1	2117	382	2440	70	CFG_GPMC_AD1_IN	vin3a_d1	-	-	-	-
J1	gpmc_ad10	1968	686	2324	406	CFG_GPMC_AD10_IN	vin3a_d10	-	-	-	-
J2	gpmc_ad11	1853	689	2278	352	CFG_GPMC_AD11_IN	vin3a_d11	-	-	-	-
H1	gpmc_ad12	1910	497	2297	160	CFG_GPMC_AD12_IN	vin3a_d12	-	-	-	-
J3	gpmc_ad13	1869	436	2278	108	CFG_GPMC_AD13_IN	vin3a_d13	-	-	-	-
H2	gpmc_ad14	1895	147	2035	0	CFG_GPMC_AD14_IN	vin3a_d14	-	-	-	-
H3	gpmc_ad15	1917	655	2279	378	CFG_GPMC_AD15_IN	vin3a_d15	-	-	-	-
L5	gpmc_ad2	2097	666	2404	446	CFG_GPMC_AD2_IN	vin3a_d2	-	-	-	-
M1	gpmc_ad3	1954	581	2343	212	CFG_GPMC_AD3_IN	vin3a_d3	-	-	-	-
L6	gpmc_ad4	2034	610	2355	322	CFG_GPMC_AD4_IN	vin3a_d4	-	-	-	-
L4	gpmc_ad5	1965	484	2337	192	CFG_GPMC_AD5_IN	vin3a_d5	-	-	-	-
L3	gpmc_ad6	1861	635	2270	314	CFG_GPMC_AD6_IN	vin3a_d6	-	-	-	-
L2	gpmc_ad7	2004	507	2339	259	CFG_GPMC_AD7_IN	vin3a_d7	-	-	-	-
L1	gpmc_ad8	1945	853	2308	577	CFG_GPMC_AD8_IN	vin3a_d8	-	-	-	-
K2	gpmc_ad9	1914	539	2334	166	CFG_GPMC_AD9_IN	vin3a_d9	-	-	-	-
N6	gpmc_ben0	1806	0	1722	0	CFG_GPMC_BEN0_IN	-	-	-	-	vin3b_de1

表 7-9. Manual Functions Mapping for VIP2 (continued)

BALL	BALL NAME	VIP2_MANUAL 1		VIP2_MANUAL2		CFG REGISTER	MUXMODE				
		A_DELAY (ps)	G_DELAY (ps)	A_DELAY (ps)	G_DELAY (ps)		2	3	4	5	6
M4	gpmc_ben1	1879	20	1840	0	CFG_GPMC_BEN1_IN	-	-	vin3b_clk1	-	vin3b_fld1
P7	gpmc_clk	0	0	0	0	CFG_GPMC_CLK_IN	-	-	vin4a_hsync0	vin4a_de0	vin3b_clk1
H6	gpmc_cs1	1505	41	1388	0	CFG_GPMC_CS1_IN	-	-	vin4a_de0	-	vin3b_vsync1
P1	gpmc_cs3	0	0	0	0	CFG_GPMC_CS3_IN	vin3a_clk0	-	-	-	-
AF1	vin1a_d16	1803	1679	2244	1202	CFG_VIN1A_D16_IN	-	-	-	-	vin3a_d0
AE3	vin1a_d17	1871	1654	2321	1116	CFG_VIN1A_D17_IN	-	-	-	-	vin3a_d1
AE5	vin1a_d18	1875	1742	2280	1288	CFG_VIN1A_D18_IN	-	-	-	-	vin3a_d2
AE1	vin1a_d19	1844	1759	2282	1281	CFG_VIN1A_D19_IN	-	-	-	-	vin3a_d3
AE2	vin1a_d20	1845	1624	2284	1090	CFG_VIN1A_D20_IN	-	-	-	-	vin3a_d4
AE6	vin1a_d21	1906	1520	2324	1000	CFG_VIN1A_D21_IN	-	-	-	-	vin3a_d5
AD2	vin1a_d22	1807	1437	2278	915	CFG_VIN1A_D22_IN	-	-	-	-	vin3a_d6
AD3	vin1a_d23	1996	997	2423	398	CFG_VIN1A_D23_IN	-	-	-	-	vin3a_d7
AH7	vin1b_clk1	0	0	0	0	CFG_VIN1B_CLK1_IN	-	-	-	-	vin3a_clk0
B2	vin2a_d16	1329	528	1779	0	CFG_VIN2A_D16_IN	-	-	-	-	vin3a_d8
D6	vin2a_d17	1270	677	1844	0	CFG_VIN2A_D17_IN	-	-	-	-	vin3a_d9
C5	vin2a_d18	1494	411	1767	0	CFG_VIN2A_D18_IN	-	-	-	-	vin3a_d10
A3	vin2a_d19	1225	154	1254	0	CFG_VIN2A_D19_IN	-	-	-	-	vin3a_d11
B3	vin2a_d20	1212	450	1597	0	CFG_VIN2A_D20_IN	-	-	-	vin3a_de0	vin3a_d12
B4	vin2a_d21	1232	494	1662	0	CFG_VIN2A_D21_IN	-	-	-	vin3a_fld0	vin3a_d13
B5	vin2a_d22	1203	503	1641	0	CFG_VIN2A_D22_IN	-	-	-	vin3a_hsync0	vin3a_d14
A4	vin2a_d23	1214	599	1748	0	CFG_VIN2A_D23_IN	-	-	-	vin3a_vsync0	vin3a_d15
D11	vout1_clk	2047	735	2391	637	CFG_VOUT1_CLK_IN	-	vin4a_fld0	vin3a_fld0	-	-
F11	vout1_d0	2135	987	2403	965	CFG_VOUT1_D0_IN	-	vin4a_d16	vin3a_d16	-	-
G10	vout1_d1	2048	955	2368	880	CFG_VOUT1_D1_IN	-	vin4a_d17	vin3a_d17	-	-
D7	vout1_d10	1970	855	2347	724	CFG_VOUT1_D10_IN	-	vin4a_d10	vin3a_d10	-	-
D8	vout1_d11	2111	893	2389	861	CFG_VOUT1_D11_IN	-	vin4a_d11	vin3a_d11	-	-
A5	vout1_d12	2018	841	2356	748	CFG_VOUT1_D12_IN	-	vin4a_d12	vin3a_d12	-	-
C6	vout1_d13	2073	805	2382	731	CFG_VOUT1_D13_IN	-	vin4a_d13	vin3a_d13	-	-
C8	vout1_d14	2112	770	2401	703	CFG_VOUT1_D14_IN	-	vin4a_d14	vin3a_d14	-	-
C7	vout1_d15	2132	831	2434	771	CFG_VOUT1_D15_IN	-	vin4a_d15	vin3a_d15	-	-

表 7-9. Manual Functions Mapping for VIP2 (continued)

BALL	BALL NAME	VIP2_MANUAL 1		VIP2_MANUAL2		CFG REGISTER	MUXMODE				
		A_DELAY (ps)	G_DELAY (ps)	A_DELAY (ps)	G_DELAY (ps)		2	3	4	5	6
B7	vout1_d16	1996	632	2338	536	CFG_VOUT1_D16_IN	-	vin4a_d0	vin3a_d0	-	-
B8	vout1_d17	2190	790	2442	775	CFG_VOUT1_D17_IN	-	vin4a_d1	vin3a_d1	-	-
A7	vout1_d18	2100	604	2385	565	CFG_VOUT1_D18_IN	-	vin4a_d2	vin3a_d2	-	-
A8	vout1_d19	2108	286	2424	168	CFG_VOUT1_D19_IN	-	vin4a_d3	vin3a_d3	-	-
F10	vout1_d2	1979	1020	2335	909	CFG_VOUT1_D2_IN	-	vin4a_d18	vin3a_d18	-	-
C9	vout1_d20	2031	967	2362	881	CFG_VOUT1_D20_IN	-	vin4a_d4	vin3a_d4	-	-
A9	vout1_d21	2039	450	2350	384	CFG_VOUT1_D21_IN	-	vin4a_d5	vin3a_d5	-	-
B9	vout1_d22	2037	583	2369	497	CFG_VOUT1_D22_IN	-	vin4a_d6	vin3a_d6	-	-
A10	vout1_d23	1768	740	2246	508	CFG_VOUT1_D23_IN	-	vin4a_d7	vin3a_d7	-	-
G11	vout1_d3	2099	881	2382	844	CFG_VOUT1_D3_IN	-	vin4a_d19	vin3a_d19	-	-
E9	vout1_d4	2120	786	2387	756	CFG_VOUT1_D4_IN	-	vin4a_d20	vin3a_d20	-	-
F9	vout1_d5	1965	857	2299	769	CFG_VOUT1_D5_IN	-	vin4a_d21	vin3a_d21	-	-
F8	vout1_d6	2139	680	2366	699	CFG_VOUT1_D6_IN	-	vin4a_d22	vin3a_d22	-	-
E7	vout1_d7	2122	912	2360	920	CFG_VOUT1_D7_IN	-	vin4a_d23	vin3a_d23	-	-
E8	vout1_d8	2073	906	2372	853	CFG_VOUT1_D8_IN	-	vin4a_d8	vin3a_d8	-	-
D9	vout1_d9	2097	934	2386	879	CFG_VOUT1_D9_IN	-	vin4a_d9	vin3a_d9	-	-
B10	vout1_de	2021	527	2366	428	CFG_VOUT1_DE_IN	-	vin4a_de0	vin3a_de0	-	-
B11	vout1_fld	0	0	0	0	CFG_VOUT1_FLD_IN	-	vin4a_clk0	vin3a_clk0	-	-
C11	vout1_hsync	1775	486	2272	164	CFG_VOUT1_HSYNC_IN	-	vin4a_hsync0	vin3a_hsync0	-	-
E11	vout1_vsync	1917	314	2301	0	CFG_VOUT1_VSYNC_IN	-	vin4a_vsync0	vin3a_vsync0	-	-

Manual IO Timings Modes must be used to ensure some IO timings for VIP2. See 表 7-2 Modes Summary for a list of IO timings requiring the use of Manual IO Timings Modes. See 表 7-10 Manual Functions Mapping for VIP2 4A for a definition of the Manual modes.

表 7-10 lists the A_DELAY and G_DELAY values needed to calculate the correct values to be set in the CFG_x registers.

表 7-10. Manual Functions Mapping for VIP2 4A

BALL	BALL NAME	VIP2_4A_MANUAL1		VIP2_4A_MANUAL2		CFG REGISTER	MUXMODE		
		A_DELAY (ps)	G_DELAY (ps)	A_DELAY (ps)	G_DELAY (ps)		3	4	5
R6	gpmc_a0	1801	521	2268	0	CFG_GPMC_A0_IN	-	vin4a_d0	-
T9	gpmc_a1	1668	488	2135	0	CFG_GPMC_A1_IN	-	vin4a_d1	-
P9	gpmc_a11	1694	308	2026	0	CFG_GPMC_A11_IN	-	vin4a_fld0	-

表 7-10. Manual Functions Mapping for VIP2 4A (continued)

BALL	BALL NAME	VIP2_4A_MANUAL1		VIP2_4A_MANUAL2		CFG REGISTER	MUXMODE		
		A_DELAY (ps)	G_DELAY (ps)	A_DELAY (ps)	G_DELAY (ps)		3	4	5
P4	gpmc_a12	0	0	0	0	CFG_GPMC_A12_IN	-	vin4a_clk0	-
R3	gpmc_a13	1529	570	2029	38	CFG_GPMC_A13_IN	-	vin4a_hsync0	-
T2	gpmc_a14	1747	753	2266	261	CFG_GPMC_A14_IN	-	vin4a_vsync0	-
U2	gpmc_a15	1536	336	1882	0	CFG_GPMC_A15_IN	-	vin4a_d8	-
U1	gpmc_a16	1662	293	1936	0	CFG_GPMC_A16_IN	-	vin4a_d9	-
P3	gpmc_a17	1637	247	1851	0	CFG_GPMC_A17_IN	-	vin4a_d10	-
R2	gpmc_a18	1454	0	1369	0	CFG_GPMC_A18_IN	-	vin4a_d11	-
K7	gpmc_a19	1577	205	1634	0	CFG_GPMC_A19_IN	-	vin4a_d12	-
T6	gpmc_a2	1891	747	2369	238	CFG_GPMC_A2_IN	-	vin4a_d2	-
M7	gpmc_a20	1398	220	1450	0	CFG_GPMC_A20_IN	-	vin4a_d13	-
J5	gpmc_a21	1521	329	1691	0	CFG_GPMC_A21_IN	-	vin4a_d14	-
K6	gpmc_a22	1383	273	1488	0	CFG_GPMC_A22_IN	-	vin4a_d15	-
J7	gpmc_a23	1163	0	1147	0	CFG_GPMC_A23_IN	-	vin4a_fld0	-
T7	gpmc_a3	1820	786	2325	271	CFG_GPMC_A3_IN	-	vin4a_d3	-
P6	gpmc_a4	1865	662	2359	126	CFG_GPMC_A4_IN	-	vin4a_d4	-
R9	gpmc_a5	1722	629	2260	53	CFG_GPMC_A5_IN	-	vin4a_d5	-
R5	gpmc_a6	1755	279	1990	0	CFG_GPMC_A6_IN	-	vin4a_d6	-
P5	gpmc_a7	1979	506	2410	0	CFG_GPMC_A7_IN	-	vin4a_d7	-
N1	gpmc_advn_ale	1793	267	2045	0	CFG_GPMC_ADVN_ALE_IN	-	vin4a_vsync0	-
P7	gpmc_clk	1738	309	2040	0	CFG_GPMC_CLK_IN	-	vin4a_hsync0	vin4a_de0
H6	gpmc_cs1	1379	95	1361	0	CFG_GPMC_CS1_IN	-	vin4a_de0	-
D11	vout1_clk	2090	401	2409	357	CFG_VOUT1_CLK_IN	vin4a_fld0	-	-
F11	vout1_d0	2139	961	2394	981	CFG_VOUT1_D0_IN	vin4a_d16	-	-
G10	vout1_d1	1993	878	2347	799	CFG_VOUT1_D1_IN	vin4a_d17	-	-
D7	vout1_d10	1976	678	2346	583	CFG_VOUT1_D10_IN	vin4a_d10	-	-
D8	vout1_d11	2135	749	2393	767	CFG_VOUT1_D11_IN	vin4a_d11	-	-
A5	vout1_d12	2014	696	2351	634	CFG_VOUT1_D12_IN	vin4a_d12	-	-
C6	vout1_d13	2035	590	2370	531	CFG_VOUT1_D13_IN	vin4a_d13	-	-
C8	vout1_d14	2108	861	2385	860	CFG_VOUT1_D14_IN	vin4a_d14	-	-
C7	vout1_d15	2074	682	2423	609	CFG_VOUT1_D15_IN	vin4a_d15	-	-
B7	vout1_d16	1976	579	2331	500	CFG_VOUT1_D16_IN	vin4a_d0	-	-
B8	vout1_d17	2203	505	2464	509	CFG_VOUT1_D17_IN	vin4a_d1	-	-

表 7-10. Manual Functions Mapping for VIP2 4A (continued)

BALL	BALL NAME	VIP2_4A_MANUAL1		VIP2_4A_MANUAL2		CFG REGISTER	MUXMODE		
		A_DELAY (ps)	G_DELAY (ps)	A_DELAY (ps)	G_DELAY (ps)		3	4	5
A7	vout1_d18	2096	412	2394	390	CFG_VOUT1_D18_IN	vin4a_d2	-	-
A8	vout1_d19	2106	72	2423	21	CFG_VOUT1_D19_IN	vin4a_d3	-	-
F10	vout1_d2	2023	648	2374	572	CFG_VOUT1_D2_IN	vin4a_d18	-	-
C9	vout1_d20	2027	767	2370	700	CFG_VOUT1_D20_IN	vin4a_d4	-	-
A9	vout1_d21	2026	184	2354	128	CFG_VOUT1_D21_IN	vin4a_d5	-	-
B9	vout1_d22	2061	195	2397	135	CFG_VOUT1_D22_IN	vin4a_d6	-	-
A10	vout1_d23	1764	607	2251	396	CFG_VOUT1_D23_IN	vin4a_d7	-	-
G11	vout1_d3	2053	757	2377	707	CFG_VOUT1_D3_IN	vin4a_d19	-	-
E9	vout1_d4	2119	617	2392	619	CFG_VOUT1_D4_IN	vin4a_d20	-	-
F9	vout1_d5	1951	712	2305	633	CFG_VOUT1_D5_IN	vin4a_d21	-	-
F8	vout1_d6	2119	515	2365	543	CFG_VOUT1_D6_IN	vin4a_d22	-	-
E7	vout1_d7	2119	779	2363	810	CFG_VOUT1_D7_IN	vin4a_d23	-	-
E8	vout1_d8	2043	807	2357	768	CFG_VOUT1_D8_IN	vin4a_d8	-	-
D9	vout1_d9	2166	643	2412	671	CFG_VOUT1_D9_IN	vin4a_d9	-	-
B10	vout1_de	1982	410	2353	314	CFG_VOUT1_DE_IN	vin4a_de0	-	-
B11	vout1_fld	0	0	0	0	CFG_VOUT1_FLD_IN	vin4a_clk0	-	-
C11	vout1_hsync	1755	305	2269	4	CFG_VOUT1_HSYNC_IN	vin4a_hsync0	-	-
E11	vout1_vsync	1924	8	2066	0	CFG_VOUT1_VSYNC_IN	vin4a_vsync0	-	-

Manual IO Timings Modes must be used to ensure some IO timings for VIP2. See [表 7-2 Modes Summary](#) for a list of IO timings requiring the use of Manual IO Timings Modes. See [表 7-11 Manual Functions Mapping for VIP2 4A IOSET3](#) for a definition of the Manual modes.

[表 7-11](#) lists the A_DELAY and G_DELAY values needed to calculate the correct values to be set in the CFG_x registers.

表 7-11. Manual Functions Mapping for VIP2 4A IOSET3

BALL	BALL NAME	VIP2_4A_IOSET3_MANUAL1		VIP2_4A_IOSET3_MANUAL2		CFG REGISTER	MUXMODE
		A_DELAY (ps)	G_DELAY (ps)	A_DELAY (ps)	G_DELAY (ps)		8
E21	gpio6_14	683	0	939	0	CFG_GPIO6_14_IN	vin4a_hsync0
F20	gpio6_15	1065	0	1321	0	CFG_GPIO6_15_IN	vin4a_vsync0
F21	gpio6_16	858	0	1114	0	CFG_GPIO6_16_IN	vin4a_fld0
B14	mcasp1_aclkr	1711	23	1990	0	CFG_MCASP1_ACLKR_IN	vin4a_d0
G13	mcasp1_axr2	2131	1054	2423	1073	CFG_MCASP1_AXR2_IN	vin4a_d2
J11	mcasp1_axr3	2267	691	2573	696	CFG_MCASP1_AXR3_IN	vin4a_d3

表 7-11. Manual Functions Mapping for VIP2 4A IOSET3 (continued)

BALL	BALL NAME	VIP2_4A_IOSET3_MANUAL1		VIP2_4A_IOSET3_MANUAL2		CFG REGISTER	MUXMODE	
		A_DELAY (ps)	G_DELAY (ps)	A_DELAY (ps)	G_DELAY (ps)		8	
E12	mcasp1_axr4	2089	813	2441	773	CFG_MCASP1_AXR4_IN	vin4a_d4	
F13	mcasp1_axr5	2061	858	2430	799	CFG_MCASP1_AXR5_IN	vin4a_d5	
C12	mcasp1_axr6	2151	595	2539	480	CFG_MCASP1_AXR6_IN	vin4a_d6	
D12	mcasp1_axr7	2112	931	2421	932	CFG_MCASP1_AXR7_IN	vin4a_d7	
J14	mcasp1_fsr	1714	323	2248	44	CFG_MCASP1_FSR_IN	vin4a_d1	
E15	mcasp2_aclkr	1462	76	1795	0	CFG_MCASP2_ACLKR_IN	vin4a_d8	
B15	mcasp2_axr0	1578	833	2113	554	CFG_MCASP2_AXR0_IN	vin4a_d10	
A15	mcasp2_axr1	1785	396	2279	212	CFG_MCASP2_AXR1_IN	vin4a_d11	
D15	mcasp2_axr4	1765	485	2299	206	CFG_MCASP2_AXR4_IN	vin4a_d12	
B16	mcasp2_axr5	1644	509	2179	230	CFG_MCASP2_AXR5_IN	vin4a_d13	
B17	mcasp2_axr6	1098	0	1354	0	CFG_MCASP2_AXR6_IN	vin4a_d14	
A17	mcasp2_axr7	1242	521	1777	243	CFG_MCASP2_AXR7_IN	vin4a_d15	
A20	mcasp2_fsr	1328	130	1713	0	CFG_MCASP2_FSR_IN	vin4a_d9	
C18	mcasp4_aclkx	1033	0	1166	0	CFG_MCASP4_ACLKX_IN	vin4a_d16	
G16	mcasp4_axr0	2147	358	2529	221	CFG_MCASP4_AXR0_IN	vin4a_d18	
D17	mcasp4_axr1	2140	676	2482	645	CFG_MCASP4_AXR1_IN	vin4a_d19	
A21	mcasp4_fsx	2140	339	2554	165	CFG_MCASP4_FSX_IN	vin4a_d17	
AA3	mcasp5_aclkx	2846	2620	3059	2547	CFG_MCASP5_ACLKX_IN	vin4a_d20	
AB3	mcasp5_axr0	2880	3301	3040	3417	CFG_MCASP5_AXR0_IN	vin4a_d22	
AA4	mcasp5_axr1	2851	3586	3042	3593	CFG_MCASP5_AXR1_IN	vin4a_d23	
AB9	mcasp5_fsx	2847	2856	3031	2890	CFG_MCASP5_FSX_IN	vin4a_d21	
B26	xref_clk2	0	0	0	0	CFG_XREF_CLK2_IN	vin4a_clk0	
C23	xref_clk3	927	0	1183	0	CFG_XREF_CLK3_IN	vin4a_de0	

Manual IO Timings Modes must be used to ensure some IO timings for VIP2. See 表 7-2 Modes Summary for a list of IO timings requiring the use of Manual IO Timings Modes. See 表 7-12 Manual Functions Mapping for VIP2 4B for a definition of the Manual modes.

表 7-12 lists the A_DELAY and G_DELAY values needed to calculate the correct values to be set in the CFG_x registers.

表 7-12. Manual Functions Mapping for VIP2 4B

BALL	BALL NAME	VIP2_4B_MANUAL1		VIP2_4B_MANUAL2		CFG REGISTER	MUXMODE	
		A_DELAY (ps)	G_DELAY (ps)	A_DELAY (ps)	G_DELAY (ps)		5	6
R6	gpmc_a0	1861	901	2102	660	CFG_GPMC_A0_IN	-	vin4b_d0

表 7-12. Manual Functions Mapping for VIP2 4B (continued)

BALL	BALL NAME	VIP2_4B_MANUAL1		VIP2_4B_MANUAL2		CFG REGISTER	MUXMODE	
		A_DELAY (ps)	G_DELAY (ps)	A_DELAY (ps)	G_DELAY (ps)		5	6
T9	gpmc_a1	1652	891	1955	583	CFG_GPMC_A1_IN	-	vin4b_d1
N9	gpmc_a10	0	0	0	0	CFG_GPMC_A10_IN	-	vin4b_clk1
P9	gpmc_a11	1783	1178	1975	1021	CFG_GPMC_A11_IN	-	vin4b_de1
P4	gpmc_a12	1903	853	2076	664	CFG_GPMC_A12_IN	-	vin4b_fld1
T6	gpmc_a2	1888	1212	2065	994	CFG_GPMC_A2_IN	-	vin4b_d2
T7	gpmc_a3	1839	1274	2025	1075	CFG_GPMC_A3_IN	-	vin4b_d3
P6	gpmc_a4	1868	1113	2058	869	CFG_GPMC_A4_IN	-	vin4b_d4
R9	gpmc_a5	1757	1079	2028	802	CFG_GPMC_A5_IN	-	vin4b_d5
R5	gpmc_a6	1800	670	2032	421	CFG_GPMC_A6_IN	-	vin4b_d6
P5	gpmc_a7	1967	898	2179	597	CFG_GPMC_A7_IN	-	vin4b_d7
N7	gpmc_a8	1731	959	1993	559	CFG_GPMC_A8_IN	-	vin4b_hsync1
R4	gpmc_a9	1766	1150	2022	834	CFG_GPMC_A9_IN	-	vin4b_vsync1
U4	mdio_d	1602	506	1931	283	CFG_MDIO_D_IN	vin4b_d0	-
V1	mdio_mclk	0	0	0	0	CFG_MDIO_MCLK_IN	vin4b_clk1	-
U5	rgmii0_rxc	1678	887	1987	663	CFG_RGMII0_RXC_IN	vin4b_d5	-
V5	rgmii0_rxctl	1595	932	1903	748	CFG_RGMII0_RXCTL_IN	vin4b_d6	-
W2	rgmii0_rxd0	1707	464	2010	160	CFG_RGMII0_RXD0_IN	vin4b_fld1	-
V4	rgmii0_rxd3	1662	1146	1943	996	CFG_RGMII0_RXD3_IN	vin4b_d7	-
W9	rgmii0_txc	1639	1195	1970	1006	CFG_RGMII0_TXC_IN	vin4b_d3	-
V9	rgmii0_txctl	1695	1226	1952	1113	CFG_RGMII0_TXCTL_IN	vin4b_d4	-
V6	rgmii0_txd1	1693	1118	1951	1003	CFG_RGMII0_TXD1_IN	vin4b_vsync1	-
U7	rgmii0_txd2	1522	1004	1895	685	CFG_RGMII0_TXD2_IN	vin4b_hsync1	-
V7	rgmii0_txd3	1777	957	2018	787	CFG_RGMII0_TXD3_IN	vin4b_de1	-
V2	uart3_rxd	1537	236	1762	0	CFG_UART3_RXD_IN	vin4b_d1	-
Y1	uart3_txd	1575	645	1933	276	CFG_UART3_TXD_IN	vin4b_d2	-

Manual IO Timings Modes must be used to ensure some IO timings for VIP2. See 表 7-2 *Modes Summary* for a list of IO timings requiring the use of Manual IO Timings Modes. See 表 7-13 *Manual Functions Mapping for VIP2 3B IOSET2* for a definition of the Manual modes.

表 7-13 lists the A_DELAY and G_DELAY values needed to calculate the correct values to be set in the CFG_x registers.

表 7-13. Manual Functions Mapping for VIP2 3B IOSET2

BALL	BALL NAME	VIP2_3B_IOSET2_MANUAL1		VIP2_3B_IOSET2_MANUAL2		CFG REGISTER	MUXMODE	
		A_DELAY (ps)	G_DELAY (ps)	A_DELAY (ps)	G_DELAY (ps)		4	6
K7	gpmc_a19	1505	1172	1854	799	CFG_GPMC_A19_IN	-	vin3b_d0
M7	gpmc_a20	1394	1074	1723	716	CFG_GPMC_A20_IN	-	vin3b_d1
J5	gpmc_a21	1452	1266	1789	900	CFG_GPMC_A21_IN	-	vin3b_d2
K6	gpmc_a22	1360	1200	1684	847	CFG_GPMC_A22_IN	-	vin3b_d3
J7	gpmc_a23	1446	735	1831	443	CFG_GPMC_A23_IN	-	vin3b_d4
J4	gpmc_a24	1329	1360	1686	970	CFG_GPMC_A24_IN	-	vin3b_d5
J6	gpmc_a25	1417	1318	1757	962	CFG_GPMC_A25_IN	-	vin3b_d6
H4	gpmc_a26	1321	1298	1680	880	CFG_GPMC_A26_IN	-	vin3b_d7
H5	gpmc_a27	1309	1215	1669	834	CFG_GPMC_A27_IN	-	vin3b_hsync1
N6	gpmc_ben0	1677	944	1994	638	CFG_GPMC_BEN0_IN	-	vin3b_de1
M4	gpmc_ben1	0	0	0	0	CFG_GPMC_BEN1_IN	vin3b_clk1	vin3b_fld1
H6	gpmc_cs1	1280	1058	1620	664	CFG_GPMC_CS1_IN	-	vin3b_vsync1

Manual IO Timings Modes must be used to ensure some IO timings for VIP3. See [表 7-2 Modes Summary](#) for a list of IO timings requiring the use of Manual IO Timings Modes. See [表 7-14 Manual Functions Mapping for VIP3](#) for a definition of the Manual modes.

[表 7-14](#) lists the A_DELAY and G_DELAY values needed to calculate the correct values to be set in the CFG_x registers.

表 7-14. Manual Functions Mapping for VIP3

BALL	BALL NAME	VIP3_MANUAL1		VIP3_MANUAL2		CFG REGISTER	MUXMODE	
		A_DELAY (ps)	G_DELAY (ps)	A_DELAY (ps)	G_DELAY (ps)		7	9
AC5	gpio6_10	774	2462	765	2551	CFG_GPIO6_10_IN	-	vin5a_clk0
AB4	gpio6_11	2453	3000	2863	2719	CFG_GPIO6_11_IN	-	vin5a_de0
C14	mcasp1_aclkx	1400	154	1698	0	CFG_MCASP1_ACLKX_IN	vin6a_fld0	-
G12	mcasp1_axr0	2055	612	2459	381	CFG_MCASP1_AXR0_IN	vin6a_vsyn c0	-
F12	mcasp1_axr1	1623	338	2098	0	CFG_MCASP1_AXR1_IN	vin6a_hsyn c0	-
B13	mcasp1_axr10	1625	92	1681	0	CFG_MCASP1_AXR10_IN	vin6a_d13	-
A12	mcasp1_axr11	1509	714	2048	317	CFG_MCASP1_AXR11_IN	vin6a_d12	-
E14	mcasp1_axr12	1189	619	1729	222	CFG_MCASP1_AXR12_IN	vin6a_d11	-
A13	mcasp1_axr13	1546	265	1954	0	CFG_MCASP1_AXR13_IN	vin6a_d10	-
G14	mcasp1_axr14	1305	0	1448	0	CFG_MCASP1_AXR14_IN	vin6a_d9	-
F14	mcasp1_axr15	1342	313	1798	0	CFG_MCASP1_AXR15_IN	vin6a_d8	-
B12	mcasp1_axr8	1833	466	2264	0	CFG_MCASP1_AXR8_IN	vin6a_d15	-
A11	mcasp1_axr9	1555	777	2029	352	CFG_MCASP1_AXR9_IN	vin6a_d14	-
D14	mcasp1_fsx	1549	281	1972	0	CFG_MCASP1_FSX_IN	vin6a_de0	-
A19	mcasp2_aclkx	1063	0	1206	0	CFG_MCASP2_ACLKX_IN	vin6a_d7	-
C15	mcasp2_axr2	1134	0	1277	0	CFG_MCASP2_AXR2_IN	vin6a_d5	-
A16	mcasp2_axr3	1348	487	1888	90	CFG_MCASP2_AXR3_IN	vin6a_d4	-
A18	mcasp2_fsx	1030	250	1424	0	CFG_MCASP2_FSX_IN	vin6a_d6	-
B18	mcasp3_aclkx	0	0	0	0	CFG_MCASP3_ACLKX_IN	vin6a_d3	-
B19	mcasp3_axr0	888	485	1428	88	CFG_MCASP3_AXR0_IN	vin6a_d1	-
C17	mcasp3_axr1	861	582	1331	254	CFG_MCASP3_AXR1_IN	vin6a_d0	vin5a_fld0
F15	mcasp3_fsx	1093	451	1633	54	CFG_MCASP3_FSX_IN	vin6a_d2	-
C18	mcasp4_aclkx	557	0	541	0	CFG_MCASP4_ACLKX_IN	-	vin5a_d15
G16	mcasp4_axr0	1027	989	1441	644	CFG_MCASP4_AXR0_IN	-	vin5a_d13
D17	mcasp4_axr1	1140	1038	1601	740	CFG_MCASP4_AXR1_IN	-	vin5a_d12
A21	mcasp4_fsx	1140	885	700	1377	CFG_MCASP4_FSX_IN	-	vin5a_d14
AA3	mcasp5_aclkx	1633	3030	1658	2999	CFG_MCASP5_ACLKX_IN	-	vin5a_d11
AB3	mcasp5_axr0	2392	3028	2816	2711	CFG_MCASP5_AXR0_IN	-	vin5a_d9
AA4	mcasp5_axr1	2435	3026	2856	2723	CFG_MCASP5_AXR1_IN	-	vin5a_d8
AB9	mcasp5_fsx	2285	2660	2713	2288	CFG_MCASP5_FSX_IN	-	vin5a_d10
AD4	mmc3_clk	2501	2822	2915	2475	CFG_MMC3_CLK_IN	-	vin5a_d7
AC4	mmc3_cmd	2423	2826	2832	2485	CFG_MMC3_CMD_IN	-	vin5a_d6
AC7	mmc3_dat0	2336	2820	2743	2526	CFG_MMC3_DAT0_IN	-	vin5a_d5
AC6	mmc3_dat1	2332	2710	2749	2346	CFG_MMC3_DAT1_IN	-	vin5a_d4
AC9	mmc3_dat2	1732	3048	1811	3012	CFG_MMC3_DAT2_IN	-	vin5a_d3
AC3	mmc3_dat3	2459	2969	2872	2683	CFG_MMC3_DAT3_IN	-	vin5a_d2
AC8	mmc3_dat4	2436	2662	2836	2271	CFG_MMC3_DAT4_IN	-	vin5a_d1
AD6	mmc3_dat5	2450	2431	1771	3271	CFG_MMC3_DAT5_IN	-	vin5a_d0

表 7-14. Manual Functions Mapping for VIP3 (continued)

BALL	BALL NAME	VIP3_MANUAL1		VIP3_MANUAL2		CFG REGISTER	MUXMODE	
		A_DELAY (ps)	G_DELAY (ps)	A_DELAY (ps)	G_DELAY (ps)		7	9
AB8	mmc3_dat6	2332	2640	2752	2255	CFG_MMC3_DAT6_IN	-	vin5a_hsyn c0
AB5	mmc3_dat7	1799	2927	1881	2844	CFG_MMC3_DAT7_IN	-	vin5a_vsyn c0
D18	xref_clk0	681	0	824	0	CFG_XREF_CLK0_IN	vin6a_d0	-
E17	xref_clk1	21	0	0	0	CFG_XREF_CLK1_IN	vin6a_clk0	-

7.7 Display Subsystem – Video Output Ports

Three Display Parallel Interfaces (DPI) channels are available in DSS named DPI Video Output 1, DPI Video Output 2 and DPI Video Output 3.

注: The DPI Video Output i (i = 1 to 3) interface is also referred to as VOUTi.

Every VOUT interface consists of:

- 24-bit data bus (data[23:0])
- Horizontal synchronization signal (HSYNC)
- Vertical synchronization signal (VSYNC)
- Data enable (DE)
- Field ID (FID)
- Pixel clock (CLK)

注: For more information, see the Display Subsystem chapter of the Device TRM.

注意

The IO timings provided in this section are only valid if signals within a single IOSET are used. The IOSETs are defined in the 表 7-19 and 表 7-20.

注意

The IO Timings provided in this section are only valid for some DSS usage modes when the corresponding Virtual IO Timings or Manual IO Timings are configured as described in the tables found in this section.

注意

All pads/balls configured as vouti_* signals are recommended to use slow slew rate by setting the corresponding CTRL_CORE_PAD_*[SLEWCONTROL] register field to SLOW (0b1). FAST slew setting is allowed, but results in faster edge rates on the VOUTn bus, higher power/ground noise, and higher EMI emissions compared to SLOW slew rate.

表 7-15, 表 7-16 and 图 7-6 assume testing over the recommended operating conditions and electrical characteristic conditions.

表 7-15. DPI Video Output i (i = 1..3) Default Switching Characteristics

NO.	PARAMETER	DESCRIPTION	MODE	MIN	MAX	UNIT
D1	$t_{c(\text{clk})}$	Cycle time, output pixel clock vouti_clk		11.76 (2)		ns
D2	$t_{w(\text{clkL})}$	Pulse duration, output pixel clock vouti_clk low	DPI1, DPI2 (IOSET1), DPI3	$P \times 0.5 - 1$ (1)		ns
			DPI2 (IOSET2)	$P \times 0.5 - 1.35$ (1)		ns
D3	$t_{w(\text{clkH})}$	Pulse duration, output pixel clock vouti_clk high	DPI1, DPI2 (IOSET1), DPI3	$P \times 0.5 - 1$ (1)		ns
			DPI2 (IOSET2)	$P \times 0.5 - 1.35$ (1)		ns
D5	$t_{d(\text{clk-dV})}$	Delay time, output pixel clock vouti_clk transition to output data vouti_d[23:0] valid	DPI1	-2.5	2.5	ns
			DPI2 (IOSET1)	-2.5	2.5	ns
			DPI2 (IOSET2)	-2.5	2.5	ns
			DPI3 (IOSET1)	-2.5	2.5	ns
			DPI3 (IOSET2/3)	-2.5	2.5	ns
D6	$t_{d(\text{clk-ctIV})}$	Delay time, output pixel clock vouti_clk transition to output control signals vouti_vsync, vouti_hsync, vouti_de, and vouti_fld valid	DPI1	-2.5	2.5	ns
			DPI2 (IOSET1)	-2.5	2.5	ns
			DPI2 (IOSET2)	-2.5	2.5	ns
			DPI3 (IOSET1)	-2.5	2.5	ns
			DPI3 (IOSET2/3)	-2.5	2.5	ns

(1) P = output vouti_clk period in ns.

(2) All pads/balls configured as vouti_* signals are recommended to use slow slew rate by setting the corresponding CTRL_CORE_PAD_*[SLEWCONTROL] register field to SLOW (0b1). FAST slew setting is allowed, but results in faster edge rates on the VOUTn bus, higher power/ground noise, and higher EMI emissions compared to SLOW slew rate.

(3) SERDES transceivers may be sensitive to the jitter profile of vouti_clk. See Application Note [SPRAC62](#) for additional guidance.

表 7-16. DPI Video Output i (i = 1..3) Alternate Switching Characteristics

NO.	PARAMETER	DESCRIPTION	MODE	MIN	MAX	UNIT
D1	$t_{c(\text{clk})}$	Cycle time, output pixel clock vouti_clk		6.06 (2)		ns
D2	$t_{w(\text{clkL})}$	Pulse duration, output pixel clock vouti_clk low		$P \times 0.5 - 1$ (1)		ns
D3	$t_{w(\text{clkH})}$	Pulse duration, output pixel clock vouti_clk high		$P \times 0.5 - 1$ (1)		ns
D5	$t_{d(\text{clk-ctIV})}$	Delay time, output pixel clock vouti_clk transition to output data vouti_d[23:0] valid	DPI1	1.51	4.55	ns
			DPI2 (IOSET1)	1.51	4.55	ns
			DPI2 (IOSET2)	1.51	4.55	ns
			DPI3	1.51	4.55	ns
D6	$t_{d(\text{clk-dV})}$	Delay time, output pixel clock vouti_clk transition to output control signals vouti_vsync, vouti_hsync, vouti_de, and vouti_fld valid	DPI1	1.51	4.55	ns
			DPI2 (IOSET1)	1.51	4.55	ns
			DPI2 (IOSET2)	1.51	4.55	ns
			DPI3	1.51	4.55	ns

(1) P = output vouti_clk period in ns.

(2) All pads/balls configured as vouti_* signals are recommended to use slow slew rate by setting the corresponding CTRL_CORE_PAD_*[SLEWCONTROL] register field to SLOW (0b1). FAST slew setting is allowed, but results in faster edge rates on the VOUTn bus, higher power/ground noise, and higher EMI emissions compared to SLOW slew rate.

(3) SERDES transceivers may be sensitive to the jitter profile of vouti_clk. See Application Note [SPRAC62](#) for additional guidance.

表 7-17. DPI Video Output i (i = 1..3) MANUAL3 Switching Characteristics

NO.	PARAMETER	DESCRIPTION	MODE	MIN	MAX	UNIT
D1	$t_{c(\text{clk})}$	Cycle time, output pixel clock vouti_clk		6.06 (2)		ns

表 7-17. DPI Video Output i (i = 1..3) MANUAL3 Switching Characteristics (continued)

NO.	PARAMETER	DESCRIPTION	MODE	MIN	MAX	UNIT
D2	$t_{w(\text{clkL})}$	Pulse duration, output pixel clock vouti_clk low		$P*0.5-1$ (1)		ns
D3	$t_{w(\text{clkH})}$	Pulse duration, output pixel clock vouti_clk high		$P*0.5-1$ (1)		ns
D5	$t_{d(\text{clk-ctIV})}$	Delay time, output pixel clock vouti_clk transition to output data vouti_d[23:0] valid	DPI1	2.85	5.56	ns
			DPI2, DPI3	2.78	5.91	ns
D6	$t_{d(\text{clk-dV})}$	Delay time, output pixel clock vouti_clk transition to output control signals vouti_vsync, vouti_hsync, vouti_de, and vouti_fld valid	DPI1	2.85	5.56	ns
			DPI2, DPI3	2.78	5.91	ns

(1) P = output vouti_clk period in ns.

(2) SERDES transceivers may be sensitive to the jitter profile of vouti_clk. See Application Note [SPRAC62](#) for additional guidance.

表 7-18. DPI Video Output i (i = 1..3) MANUAL4 Switching Characteristics

NO.	PARAMETER	DESCRIPTION	MODE	MIN	MAX	UNIT
D1	$t_{c(\text{clk})}$	Cycle time, output pixel clock vouti_clk		6.06 (2)		ns
D2	$t_{w(\text{clkL})}$	Pulse duration, output pixel clock vouti_clk low		$P*0.5-1$ (1)		ns
D3	$t_{w(\text{clkH})}$	Pulse duration, output pixel clock vouti_clk high		$P*0.5-1$ (1)		ns
D5	$t_{d(\text{clk-ctIV})}$	Delay time, output pixel clock vouti_clk transition to output data vouti_d[23:0] valid	DPI1, DPI2, DPI3	3.55	6.61	ns
D6	$t_{d(\text{clk-dV})}$	Delay time, output pixel clock vouti_clk transition to output control signals vouti_vsync, vouti_hsync, vouti_de, and vouti_fld valid	DPI1, DPI2, DPI3	3.55	6.61	ns

- (1) P = output vouti_clk period in ns.
- (2) SERDES transceivers may be sensitive to the jitter profile of vouti_clk. See Application Note [SPRAC62](#) for additional guidance.



图 7-6. DPI Video Output^{(1) (2)(3)}

- (1) The configuration of assertion of the data can be programmed on the falling or rising edge of the pixel clock.
- (2) The polarity and the pulse width of vouti_hsync and vouti_vsync are programmable, refer to the DSS section of the device TRM.
- (3) The vouti_clk frequency can be configured, refer to the DSS section of the device TRM.

注: To configure the desired virtual mode the user must set MODESELECT bit and DELAYMODE bitfield for each corresponding pad control register.

The pad control registers are presented in 表 4-3 and described in Device TRM, *Chapter 18 - Control Module*.

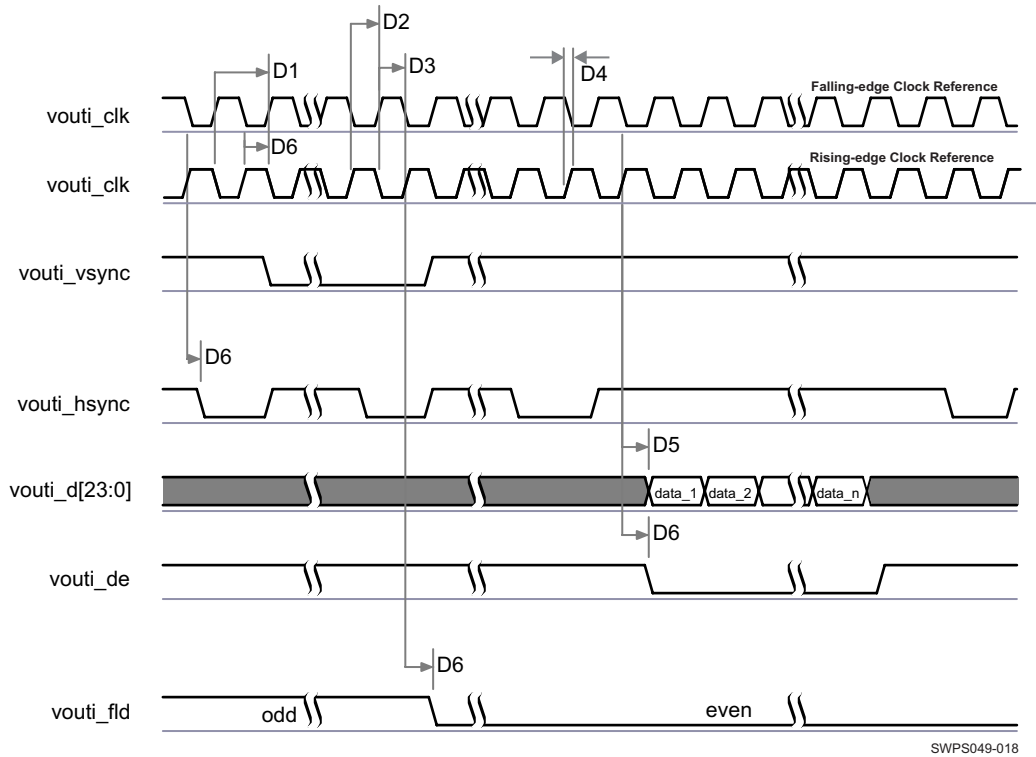
In 表 7-19 are presented the specific groupings of signals (IOSET) for use with VOUT2.

表 7-19. VOUT2 IOSETs

SIGNALS	IOSET1		IOSET2	
	BALL	MUX	BALL	MUX
vout2_d23	F2	4	AA4	6
vout2_d22	F3	4	AB3	6
vout2_d21	D1	4	AB9	6
vout2_d20	E2	4	AA3	6
vout2_d19	D2	4	D17	6
vout2_d18	F4	4	G16	6
vout2_d17	C1	4	A21	6
vout2_d16	E4	4	C18	6
vout2_d15	F5	4	A17	6
vout2_d14	E6	4	B17	6

表 7-19. VOUT2 IOSETs (continued)

SIGNALS	IOSET1		IOSET2	
	BALL	MUX	BALL	MUX
vout2_d13	D3	4	B16	6
vout2_d12	F6	4	D15	6
vout2_d11	D5	4	A15	6
vout2_d10	C2	4	B15	6
vout2_d9	C3	4	A20	6
vout2_d8	C4	4	E15	6
vout2_d7	B2	4	D12	6
vout2_d6	D6	4	C12	6
vout2_d5	C5	4	F13	6
vout2_d4	A3	4	E12	6
vout2_d3	B3	4	J11	6
vout2_d2	B4	4	G13	6
vout2_d1	B5	4	J14	6
vout2_d0	A4	4	B14	6
vout2_vsync	G6	4	F20	6
vout2_hsync	G1	4	E21	6
vout2_clk	H7	4	B26	6
vout2 fld	E1	4	F21	6
vout2_de	G2	4	C23	6

In 表 7-20 are presented the specific groupings of signals (IOSET) for use with VOUT3.

表 7-20. VOUT3 IOSETs

SIGNALS	IOSET1		IOSET2 ⁽¹⁾		IOSET3 ⁽¹⁾	
	BALL	MUX	BALL	MUX	BALL	MUX
vout3_d23	P5	3	AE8	4		
vout3_d22	R5	3	AD8	4		
vout3_d21	R9	3	AG7	4		
vout3_d20	P6	3	AH6	4		
vout3_d19	T7	3	AH3	4		
vout3_d18	T6	3	AH5	4		
vout3_d17	T9	3	AG6	4	AD9	3
vout3_d16	R6	3	AH4	4	AG8	3
vout3_d15	H3	3	AG4	4	AG4	4
vout3_d14	H2	3	AG2	4	AG2	4
vout3_d13	J3	3	AG3	4	AG3	4
vout3_d12	H1	3	AG5	4	AG5	4
vout3_d11	J2	3	AF2	4	AF2	4
vout3_d10	J1	3	AF6	4	AF6	4
vout3_d9	K2	3	AF3	4	AF3	4
vout3_d8	L1	3	AF4	4	AF4	4
vout3_d7	L2	3	AF1	4	AE8	3
vout3_d6	L3	3	AE3	4	AD8	3
vout3_d5	L4	3	AE5	4	AG7	3
vout3_d4	L6	3	AE1	4	AH6	3
vout3_d3	M1	3	AE2	4	AH3	3
vout3_d2	L5	3	AE6	4	AH5	3

表 7-20. VOUT3 IOSETs (continued)

SIGNALS	IOSET1		IOSET2 ⁽¹⁾		IOSET3 ⁽¹⁾	
	BALL	MUX	BALL	MUX	BALL	MUX
vout3_d1	M2	3	AD2	4	AG6	3
vout3_d0	M6	3	AD3	4	AH4	3
vout3_de	N9	3	AD9	4		
vout3_vsync	R4	3	AF8	4	AF8	4
vout3_clk	P1	3	AF9	4	AF9	4
vout3_hsync	N7	3	AE9	4	AE9	4
vout3 fld	P9	3	AG8	4		

(1) The VOUT3 interface when multiplexed onto balls mapped to the VDDSHV6 supply rail is restricted to operating in 1.8V mode only (VDDSHV6 must be supplied with 1.8V). 3.3V mode is not supported. This must be considered in the pin mux programming and VDDSHVx supply connections.

注: To configure the desired Manual IO Timing Mode the user must follow the steps described in section "Manual IO Timing Modes" of the Device TRM.

The associated registers to configure are listed in the **CFG REGISTER** column. For more information please see the *Control Module Chapter* in the Device TRM.

Manual IO Timings Modes must be used to ensure some IO timings for VOUT1. See [表 7-2 Modes Summary](#) for a list of IO timings requiring the use of Manual IO Timings Modes. See [表 7-21 Manual Functions Mapping for DSS VOUT1](#) for a definition of the Manual modes.

[表 7-21](#) lists the A_DELAY and G_DELAY values needed to calculate the correct values to be set in the CFG_x registers.

表 7-21. Manual Functions Mapping for DSS VOUT1

BALL	BALL NAME	VOUT1_MANUAL1		VOUT1_MANUAL2		VOUT1_MANUAL3		VOUT1_MANUAL4		CFG REGISTER	MUXMODE
		A_DELAY (ps)	G_DELAY (ps)	A_DELAY (ps)	G_DELAY (ps)	A_DELAY (ps)	G_DELAY (ps)	A_DELAY (ps)	G_DELAY (ps)		0
D11	vout1_clk	0	706	1126	751	0	466	0	466	CFG_VOUT1_CLK_OUT	vout1_clk
F11	vout1_d0	2313	0	395	0	3436	0	4306	0	CFG_VOUT1_D0_OUT	vout1_d0
G10	vout1_d1	2439	0	521	0	3562	0	4432	0	CFG_VOUT1_D1_OUT	vout1_d1
D7	vout1_d10	2199	0	282	0	3323	0	3993	0	CFG_VOUT1_D10_OUT	vout1_d10
D8	vout1_d11	2266	0	348	0	3390	0	4060	0	CFG_VOUT1_D11_OUT	vout1_d11
A5	vout1_d12	3159	0	1240	0	4281	0	4951	0	CFG_VOUT1_D12_OUT	vout1_d12
C6	vout1_d13	2100	0	182	0	3223	0	4093	0	CFG_VOUT1_D13_OUT	vout1_d13
C8	vout1_d14	2229	0	311	0	3353	0	4223	0	CFG_VOUT1_D14_OUT	vout1_d14
C7	vout1_d15	2202	0	285	0	3326	0	4196	0	CFG_VOUT1_D15_OUT	vout1_d15
B7	vout1_d16	2084	0	166	0	3208	0	4078	0	CFG_VOUT1_D16_OUT	vout1_d16
B8	vout1_d17	2195	0	278	0	3319	0	4189	0	CFG_VOUT1_D17_OUT	vout1_d17
A7	vout1_d18	2342	0	425	0	3466	0	4136	0	CFG_VOUT1_D18_OUT	vout1_d18
A8	vout1_d19	2463	0	516	0	3557	0	4227	0	CFG_VOUT1_D19_OUT	vout1_d19
F10	vout1_d2	2200	0	282	0	3324	0	4194	0	CFG_VOUT1_D2_OUT	vout1_d2
C9	vout1_d20	2304	0	386	0	3428	0	4298	0	CFG_VOUT1_D20_OUT	vout1_d20
A9	vout1_d21	2103	0	111	0	3193	0	4063	0	CFG_VOUT1_D21_OUT	vout1_d21
B9	vout1_d22	2145	0	227	0	3268	0	4138	0	CFG_VOUT1_D22_OUT	vout1_d22
A10	vout1_d23	1932	0	0	0	3039	0	3909	0	CFG_VOUT1_D23_OUT	vout1_d23
G11	vout1_d3	2355	0	438	0	3479	0	4349	0	CFG_VOUT1_D3_OUT	vout1_d3
E9	vout1_d4	3215	0	1298	0	4339	0	5209	0	CFG_VOUT1_D4_OUT	vout1_d4
F9	vout1_d5	2314	0	397	0	3438	0	4308	0	CFG_VOUT1_D5_OUT	vout1_d5
F8	vout1_d6	2238	0	321	0	3362	0	4082	0	CFG_VOUT1_D6_OUT	vout1_d6
E7	vout1_d7	2381	0	155	309	3505	0	4175	0	CFG_VOUT1_D7_OUT	vout1_d7
E8	vout1_d8	2138	0	212	0	3253	0	4123	0	CFG_VOUT1_D8_OUT	vout1_d8
D9	vout1_d9	2383	0	466	0	3507	0	4377	0	CFG_VOUT1_D9_OUT	vout1_d9
B10	vout1_de	1984	0	0	0	3085	0	3955	0	CFG_VOUT1_DE_OUT	vout1_de
B11	vout1_fld	2265	0	236	0	3337	0	4207	0	CFG_VOUT1_FLD_OUT	vout1_fld
C11	vout1_hsync	1947	0	0	0	3052	0	3922	0	CFG_VOUT1_HSYNC_OUT	vout1_hsync
E11	vout1_vsync	2739	0	139	701	3863	0	4733	0	CFG_VOUT1_VSYNC_OUT	vout1_vsync

Manual IO Timings Modes must be used to ensure some IO timings for VOUT2. See [表 7-2 Modes Summary](#) for a list of IO timings requiring the use of Manual IO Timings Modes. See [表 7-22 Manual Functions Mapping for DSS VOUT2](#) for a definition of the Manual modes.

[表 7-22](#) lists the A_DELAY and G_DELAY values needed to calculate the correct values to be set in the CFG_x registers.

表 7-22. Manual Functions Mapping for DSS VOUT2 IOSET1

BALL	BALL NAME	VOUT2_IOSET1_MANUAL 1		VOUT2_IOSET1_MANUAL 2		VOUT2_IOSET1_MANUAL 3		VOUT2_IOSET1_MANUAL 4		CFG REGISTER	MUXMODE 4
		A_DELAY (ps)	G_DELAY (ps)	A_DELAY (ps)	G_DELAY (ps)	A_DELAY (ps)	G_DELAY (ps)	A_DELAY (ps)	G_DELAY (ps)		
E1	vin2a_clk0	2718	0	819	0	3794	0	4664	0	CFG_VIN2A_CLK0_OUT	vout2_fld
F2	vin2a_d0	2680	0	485	296	3757	0	4627	0	CFG_VIN2A_D0_OUT	vout2_d23
F3	vin2a_d1	2633	0	733	0	3710	0	4580	0	CFG_VIN2A_D1_OUT	vout2_d22
D3	vin2a_d10	1867	0	0	0	2954	0	3824	0	CFG_VIN2A_D10_OUT	vout2_d13
F6	vin2a_d11	2457	0	431	127	3534	0	4404	0	CFG_VIN2A_D11_OUT	vout2_d12
D5	vin2a_d12	2683	1016	1286	514	3628	648	4498	648	CFG_VIN2A_D12_OUT	vout2_d11
C2	vin2a_d13	2629	985	1229	486	3569	622	4439	622	CFG_VIN2A_D13_OUT	vout2_d10
C3	vin2a_d14	2531	804	1126	309	3460	452	4530	452	CFG_VIN2A_D14_OUT	vout2_d9
C4	vin2a_d15	2624	818	1227	315	3567	452	4537	452	CFG_VIN2A_D15_OUT	vout2_d8
B2	vin2a_d16	2747	767	1357	256	3704	386	4574	386	CFG_VIN2A_D16_OUT	vout2_d7
D6	vin2a_d17	2622	841	1226	337	3616	474	4686	474	CFG_VIN2A_D17_OUT	vout2_d6
C5	vin2a_d18	2328	0	430	0	3406	0	4276	0	CFG_VIN2A_D18_OUT	vout2_d5
A3	vin2a_d19	2300	0	401	0	3427	0	4197	0	CFG_VIN2A_D19_OUT	vout2_d4
D1	vin2a_d2	2452	0	446	106	3528	0	4398	0	CFG_VIN2A_D2_OUT	vout2_d21
B3	vin2a_d20	1998	0	98	0	3075	0	3845	0	CFG_VIN2A_D20_OUT	vout2_d3
B4	vin2a_d21	1953	0	54	0	3030	0	3900	0	CFG_VIN2A_D21_OUT	vout2_d2
B5	vin2a_d22	1893	0	0	0	3030	0	3900	0	CFG_VIN2A_D22_OUT	vout2_d1
A4	vin2a_d23	1936	0	36	0	3013	0	3883	0	CFG_VIN2A_D23_OUT	vout2_d0
E2	vin2a_d3	2494	0	595	0	3571	0	4441	0	CFG_VIN2A_D3_OUT	vout2_d20
D2	vin2a_d4	3001	153	1254	0	4231	0	4901	0	CFG_VIN2A_D4_OUT	vout2_d19
F4	vin2a_d5	2463	0	563	0	3539	0	4409	0	CFG_VIN2A_D5_OUT	vout2_d18
C1	vin2a_d6	2456	0	558	0	3334	0	4404	0	CFG_VIN2A_D6_OUT	vout2_d17
E4	vin2a_d7	2431	0	532	0	3509	0	4379	0	CFG_VIN2A_D7_OUT	vout2_d16
F5	vin2a_d8	2262	0	363	0	3340	0	4210	0	CFG_VIN2A_D8_OUT	vout2_d15
E6	vin2a_d9	2145	0	246	0	3222	0	4092	0	CFG_VIN2A_D9_OUT	vout2_d14
G2	vin2a_de0	2597	0	550	149	3675	0	4545	0	CFG_VIN2A_DE0_OUT	vout2_de
H7	vin2a_fld0	0	957	1208	969	0	686	0	686	CFG_VIN2A_FLD0_OUT	vout2_clk

表 7-22. Manual Functions Mapping for DSS VOUT2 IOSET1 (continued)

BALL	BALL NAME	VOUT2_IOSET1_MANUAL 1		VOUT2_IOSET1_MANUAL 2		VOUT2_IOSET1_MANUAL 3		VOUT2_IOSET1_MANUAL 4		CFG REGISTER	MUXMODE 4
		A_DELAY (ps)	G_DELAY (ps)	A_DELAY (ps)	G_DELAY (ps)	A_DELAY (ps)	G_DELAY (ps)	A_DELAY (ps)	G_DELAY (ps)		
G1	vin2a_hsync 0	2958	0	1059	0	4035	0	4905	0	CFG_VIN2A_HSYNC0_OUT	vout2_hsync
G6	vin2a_vsync 0	2752	0	853	0	3829	0	4699	0	CFG_VIN2A_VSYNC0_OUT	vout2_vsync

Manual IO Timings Modes must be used to ensure some IO timings for VOUT2. See 表 7-2 Modes Summary for a list of IO timings requiring the use of Manual IO Timings Modes. See 表 7-23 Manual Functions Mapping for DSS VOUT2 IOSET2 for a definition of the Manual modes.

表 7-23 lists the A_DELAY and G_DELAY values needed to calculate the correct values to be set in the CFG_x registers.

表 7-23. Manual Functions Mapping for DSS VOUT2 IOSET2

BALL	BALL NAME	VOUT2_IOSET2_MANUAL 1		VOUT2_IOSET2_MANUAL 2		VOUT2_IOSET2_MANUAL 3		VOUT2_IOSET2_MANUAL 4		CFG REGISTER	MUXMODE 6
		A_DELAY (ps)	G_DELAY (ps)	A_DELAY (ps)	G_DELAY (ps)	A_DELAY (ps)	G_DELAY (ps)	A_DELAY (ps)	G_DELAY (ps)		
E21	gpio6_14	1547	30	0	0	2298	0	3168	0	CFG_GPIO6_14_OUT	vout2_hsync
F20	gpio6_15	1773	31	209	0	2484	0	3354	0	CFG_GPIO6_15_OUT	vout2_vsync
F21	gpio6_16	1547	27	33	0	2345	0	3215	0	CFG_GPIO6_16_OUT	vout2_fld
B14	mcasp1_aclkr	3738	2	2636	0	4925	0	5795	0	CFG_MCASP1_ACLKR_OUT	vout2_d0
G13	mcasp1_axr 2	2846	4	1730	0	4003	0	4873	0	CFG_MCASP1_AXR2_OUT	vout2_d2
J11	mcasp1_axr 3	2831	17	1498	0	3771	0	4541	0	CFG_MCASP1_AXR3_OUT	vout2_d3
E12	mcasp1_axr 4	3009	5	1879	0	4152	0	5022	0	CFG_MCASP1_AXR4_OUT	vout2_d4
F13	mcasp1_axr 5	3009	9	1802	0	4075	0	4945	0	CFG_MCASP1_AXR5_OUT	vout2_d5
C12	mcasp1_axr 6	2875	2	1792	0	4065	0	4935	0	CFG_MCASP1_AXR6_OUT	vout2_d6
D12	mcasp1_axr 7	2893	7	1717	0	3991	0	4861	0	CFG_MCASP1_AXR7_OUT	vout2_d7
J14	mcasp1_fsr	2729	13	1466	0	3739	0	4609	0	CFG_MCASP1_FSR_OUT	vout2_d1
E15	mcasp2_aclkr	3753	13	2488	0	4761	0	5631	0	CFG_MCASP2_ACLKR_OUT	vout2_d8

表 7-23. Manual Functions Mapping for DSS VOUT2 IOSET2 (continued)

BALL	BALL NAME	VOUT2_IOSET2_MANUAL 1		VOUT2_IOSET2_MANUAL 2		VOUT2_IOSET2_MANUAL 3		VOUT2_IOSET2_MANUAL 4		CFG REGISTER	MUXMODE 6
		A_DELAY (ps)	G_DELAY (ps)	A_DELAY (ps)	G_DELAY (ps)	A_DELAY (ps)	G_DELAY (ps)	A_DELAY (ps)	G_DELAY (ps)		
B15	mcasp2_axr0	2182	6	1022	0	3294	0	4164	0	CFG_MCASP2_AXR0_OUT	vout2_d10
A15	mcasp2_axr1	2324	5	1179	0	3452	0	4322	0	CFG_MCASP2_AXR1_OUT	vout2_d11
D15	mcasp2_axr4	2434	0	1374	0	3647	0	4517	0	CFG_MCASP2_AXR4_OUT	vout2_d12
B16	mcasp2_axr5	2287	4	1164	0	3437	0	4307	0	CFG_MCASP2_AXR5_OUT	vout2_d13
B17	mcasp2_axr6	3598	13	2339	0	4599	0	5469	0	CFG_MCASP2_AXR6_OUT	vout2_d14
A17	mcasp2_axr7	2231	15	931	0	3204	0	4074	0	CFG_MCASP2_AXR7_OUT	vout2_d15
A20	mcasp2_fsr	1944	11	715	0	2988	0	3858	0	CFG_MCASP2_FSR_OUT	vout2_d9
C18	mcasp4_aclkx	3241	8	2051	0	4324	0	5194	0	CFG_MCASP4_ACLKX_OUT	vout2_d16
G16	mcasp4_axr0	2236	22	830	0	3090	0	3960	0	CFG_MCASP4_AXR0_OUT	vout2_d18
D17	mcasp4_axr1	1803	16	505	0	2766	0	3636	0	CFG_MCASP4_AXR1_OUT	vout2_d19
A21	mcasp4_fsx	1901	19	541	0	2801	0	3671	0	CFG_MCASP4_FSX_OUT	vout2_d17
AA3	mcasp5_aclkx	4582	2178	3499	1978	6020	1755	6890	1755	CFG_MCASP5_ACLKX_OUT	vout2_d20
AB3	mcasp5_axr0	4628	1604	3505	1402	6025	1178	6895	1178	CFG_MCASP5_AXR0_OUT	vout2_d22
AA4	mcasp5_axr1	4757	1237	3457	1063	5987	806	6857	806	CFG_MCASP5_AXR1_OUT	vout2_d23
AB9	mcasp5_fsx	4683	1485	3443	1280	5961	1059	6831	1059	CFG_MCASP5_FSX_OUT	vout2_d21
B26	xref_clk2	0	850	1900	1150	0	730	0	730	CFG_XREF_CLK2_OUT	vout2_clk
C23	xref_clk3	3075	19	1752	0	4012	0	4882	0	CFG_XREF_CLK3_OUT	vout2_de

Manual IO Timings Modes must be used to ensure some IO timings for VOUT3. See 表 7-2 Modes Summary for a list of IO timings requiring the use of Manual IO Timings Modes. See 表 7-24 Manual Functions Mapping for DSS VOUT3 for a definition of the Manual modes.

表 7-24 lists the A_DELAY and G_DELAY values needed to calculate the correct values to be set in the CFG_x registers.

表 7-24. Manual Functions Mapping for DSS VOUT3

BALL	BALL NAME	VOUT3_MANUAL1		VOUT3_MANUAL2		VOUT3_MANUAL3		VOUT3_MANUAL4		CFG REGISTER	MUXMODE	
		A_DELAY (ps)	G_DELAY (ps)	A_DELAY (ps)	G_DELAY (ps)	A_DELAY (ps)	G_DELAY (ps)	A_DELAY (ps)	G_DELAY (ps)		3	4
R6	gpmc_a0	3069	0	565	267	3365	0	4235	0	CFG_GPMC_A0_OUT	vout3_d16	-
T9	gpmc_a1	2888	0	650	0	3183	0	4053	0	CFG_GPMC_A1_OUT	vout3_d17	-
N9	gpmc_a10	3595	0	1157	0	3690	0	4560	0	CFG_GPMC_A10_OUT	vout3_de	-
P9	gpmc_a11	3891	14	669	970	4170	0	5040	0	CFG_GPMC_A11_OUT	vout3_fld	-
T6	gpmc_a2	2934	0	705	0	3238	0	4108	0	CFG_GPMC_A2_OUT	vout3_d18	-
T7	gpmc_a3	3944	4	1521	0	4054	0	4924	0	CFG_GPMC_A3_OUT	vout3_d19	-
P6	gpmc_a4	4456	261	1837	0	4370	0	5240	0	CFG_GPMC_A4_OUT	vout3_d20	-
R9	gpmc_a5	2915	0	739	0	3273	0	4143	0	CFG_GPMC_A5_OUT	vout3_d21	-
R5	gpmc_a6	3192	0	937	0	3471	0	4341	0	CFG_GPMC_A6_OUT	vout3_d22	-
P5	gpmc_a7	3182	0	944	0	3477	0	4347	0	CFG_GPMC_A7_OUT	vout3_d23	-
N7	gpmc_a8	4124	75	1843	0	4375	0	5245	0	CFG_GPMC_A8_OUT	vout3_hsync	-
R4	gpmc_a9	4252	0	998	0	3530	0	4400	0	CFG_GPMC_A9_OUT	vout3_vsync	-
M6	gpmc_ad0	3501	52	1151	0	3684	0	4534	0	CFG_GPMC_AD0_OUT	vout3_d0	-
M2	gpmc_ad1	3163	0	956	0	3489	0	4339	0	CFG_GPMC_AD1_OUT	vout3_d1	-
J1	gpmc_ad10	3130	0	1064	0	3598	0	4148	0	CFG_GPMC_AD10_OUT	vout3_d10	-
J2	gpmc_ad11	2821	0	809	0	3344	0	3894	0	CFG_GPMC_AD11_OUT	vout3_d11	-
H1	gpmc_ad12	3290	0	1161	0	3694	0	4244	0	CFG_GPMC_AD12_OUT	vout3_d12	-
J3	gpmc_ad13	2573	0	524	0	3058	0	3908	0	CFG_GPMC_AD13_OUT	vout3_d13	-
H2	gpmc_ad14	2540	0	632	0	3165	0	3715	0	CFG_GPMC_AD14_OUT	vout3_d14	-
H3	gpmc_ad15	3181	0	1012	0	3545	0	4295	0	CFG_GPMC_AD15_OUT	vout3_d15	-
L5	gpmc_ad2	3550	45	1222	0	3756	0	4506	0	CFG_GPMC_AD2_OUT	vout3_d2	-
M1	gpmc_ad3	2922	0	875	0	3408	0	4158	0	CFG_GPMC_AD3_OUT	vout3_d3	-
L6	gpmc_ad4	3463	36	1170	0	3703	0	4453	0	CFG_GPMC_AD4_OUT	vout3_d4	-
L4	gpmc_ad5	2299	17	358	0	2930	0	3780	0	CFG_GPMC_AD5_OUT	vout3_d5	-
L3	gpmc_ad6	3346	0	1184	0	3717	0	4267	0	CFG_GPMC_AD6_OUT	vout3_d6	-
L2	gpmc_ad7	2971	0	908	0	3441	0	3991	0	CFG_GPMC_AD7_OUT	vout3_d7	-
L1	gpmc_ad8	874	234	0	0	1923	0	2873	0	CFG_GPMC_AD8_OUT	vout3_d8	-
K2	gpmc_ad9	1160	221	0	0	2402	0	3252	0	CFG_GPMC_AD9_OUT	vout3_d9	-
P1	gpmc_cs3	0	600	1505	1379	0	947	0	947	CFG_GPMC_CS3_OUT	vout3_clk	-
AG8	vin1a_clk0	2670	0	1280	0	3511	0	4381	0	CFG_VIN1A_CLK0_OUT	vout3_d16	vout3_fld
AE8	vin1a_d0	2750	196	1286	0	3820	0	4690	0	CFG_VIN1A_D0_OUT	vout3_d7	vout3_d23
AD8	vin1a_d1	2409	240	1282	0	3816	0	4686	0	CFG_VIN1A_D1_OUT	vout3_d6	vout3_d22

表 7-24. Manual Functions Mapping for DSS VOUT3 (continued)

BALL	BALL NAME	VOUT3_MANUAL1		VOUT3_MANUAL2		VOUT3_MANUAL3		VOUT3_MANUAL4		CFG REGISTER	MUXMODE	
		A_DELAY (ps)	G_DELAY (ps)	A_DELAY (ps)	G_DELAY (ps)	A_DELAY (ps)	G_DELAY (ps)	A_DELAY (ps)	G_DELAY (ps)		3	4
AG3	vin1a_d10	3026	270	1038	622	4228	0	5098	0	CFG_VIN1A_D10_OUT	-	vout3_d13
AG5	vin1a_d11	2711	203	1141	0	3867	0	4737	0	CFG_VIN1A_D11_OUT	-	vout3_d12
AF2	vin1a_d12	2924	539	1154	0	4422	0	5292	0	CFG_VIN1A_D12_OUT	-	vout3_d11
AF6	vin1a_d13	2861	235	1339	0	3815	0	4685	0	CFG_VIN1A_D13_OUT	-	vout3_d10
AF3	vin1a_d14	3176	377	892	0	4559	0	5429	0	CFG_VIN1A_D14_OUT	-	vout3_d9
AF4	vin1a_d15	2806	232	1221	89	3755	0	4625	0	CFG_VIN1A_D15_OUT	-	vout3_d8
AF1	vin1a_d16	2402	396	692	0	3873	0	4743	0	CFG_VIN1A_D16_OUT	-	vout3_d7
AE3	vin1a_d17	2132	374	353	0	3860	0	4730	0	CFG_VIN1A_D17_OUT	-	vout3_d6
AE5	vin1a_d18	2547	284	1109	0	3857	0	4727	0	CFG_VIN1A_D18_OUT	-	vout3_d5
AE1	vin1a_d19	2095	575	640	180	3929	0	4799	0	CFG_VIN1A_D19_OUT	-	vout3_d4
AG7	vin1a_d2	2546	189	1273	0	3806	0	4476	0	CFG_VIN1A_D2_OUT	vout3_d5	vout3_d21
AE2	vin1a_d20	1825	735	628	0	3552	0	4622	0	CFG_VIN1A_D20_OUT	-	vout3_d3
AE6	vin1a_d21	2720	210	1322	0	4021	0	4891	0	CFG_VIN1A_D21_OUT	-	vout3_d2
AD2	vin1a_d22	2361	413	746	0	3659	0	4729	0	CFG_VIN1A_D22_OUT	-	vout3_d1
AD3	vin1a_d23	2731	273	1547	0	3775	0	4845	0	CFG_VIN1A_D23_OUT	-	vout3_d0
AH6	vin1a_d3	2534	219	1357	0	3890	0	4760	0	CFG_VIN1A_D3_OUT	vout3_d4	vout3_d20
AH3	vin1a_d4	3015	538	2033	19	4585	0	5455	0	CFG_VIN1A_D4_OUT	vout3_d3	vout3_d19
AH5	vin1a_d5	2451	237	1039	0	3572	0	4442	0	CFG_VIN1A_D5_OUT	vout3_d2	vout3_d18
AG6	vin1a_d6	2505	191	1230	0	3763	0	4433	0	CFG_VIN1A_D6_OUT	vout3_d1	vout3_d17
AH4	vin1a_d7	2550	170	1235	0	3768	0	4638	0	CFG_VIN1A_D7_OUT	vout3_d0	vout3_d16
AG4	vin1a_d8	2847	285	1219	0	3850	0	4720	0	CFG_VIN1A_D8_OUT	-	vout3_d15
AG2	vin1a_d9	2857	247	1113	256	3900	0	4770	0	CFG_VIN1A_D9_OUT	-	vout3_d14
AD9	vin1a_de0	3164	0	1494	0	3728	0	4848	0	CFG_VIN1A_DE0_OUT	vout3_d17	vout3_de
AF9	vin1a_fld0	0	1100	1718	869	261	384	261	384	CFG_VIN1A_FLD0_OUT	-	vout3_clk
AE9	vin1a_hsync0	3171	41	1439	0	3798	0	4668	0	CFG_VIN1A_HSYNC0_OUT	-	vout3_hsync
AF8	vin1a_vsync0	2956	110	1268	88	3610	0	4480	0	CFG_VIN1A_VSYNC0_OUT	-	vout3_vsync

7.8 Display Subsystem – High-Definition Multimedia Interface (HDMI)

The High-Definition Multimedia Interface is provided for transmitting digital television audiovisual signals from DVD players, set-top boxes and other audiovisual sources to television sets, projectors and other video displays. The HDMI interface is aligned with the HDMI TMDS single stream standard v1.4a (720p @60Hz to 1080p @24Hz) and the HDMI v1.3 (1080p @60Hz): 3 data channels, plus 1 clock channel is supported (differential).

注: For more information, see the High-Definition Multimedia Interface chapter of the device TRM.

7.9 External Memory Interface (EMIF)

The device has a dedicated interface to DDR3 and DDR2 SDRAM. It supports JEDEC standard compliant DDR2 and DDR3 SDRAM devices with the following features:

- 16-bit or 32-bit data path to external SDRAM memory
- Memory device capacity: 128Mb, 256Mb, 512Mb, 1Gb, 2Gb, 4Gb and 8Gb devices (Single die only)
- One interface with associated DDR2/DDR3 PHYs

注: For more information, see the EMIF Controller section of the Device TRM.

7.10 General-Purpose Memory Controller (GPMC)

The GPMC is the unified memory controller that interfaces external memory devices such as:

- Asynchronous SRAM-like memories and ASIC devices
- Asynchronous page mode and synchronous burst NOR flash
- NAND flash

注: For more information, see the General-Purpose Memory Controller section of the Device TRM.

7.10.1 GPMC/NOR Flash Interface Synchronous Timing

注意

The IO Timings provided in this section are only valid for some GPMC usage modes when the corresponding Virtual IO Timings or Manual IO Timings are configured as described in the tables found in this section.

表 7-25 和 表 7-26 假设测试 over 的推荐操作条件和电气特性条件如下 (see 图 7-7, 图 7-8, 图 7-9, 图 7-10, 图 7-11, 和 图 7-12).

表 7-25. GPMC/NOR Flash Interface Timing Requirements - Synchronous Mode - Default

NO.	PARAMETER	DESCRIPTION	MIN	MAX	UNIT
F12	$t_{su(dV-clkH)}$	Setup time, read gpmc_ad[15:0] valid before gpmc_clk high	2.69		ns
F13	$t_{h(clkH-dV)}$	Hold time, read gpmc_ad[15:0] valid after gpmc_clk high	1.53		ns
F21	$t_{su(waitV-clkH)}$	Setup time, gpmc_wait[1:0] valid before gpmc_clk high	2.23		ns
F22	$t_{h(clkH-waitV)}$	Hold Time, gpmc_wait[1:0] valid after gpmc_clk high	1.52		ns

注: Wait monitoring support is limited to a WaitMonitoringTime value > 0. For a full description of wait monitoring feature, see General-Purpose Memory Controller section in the Device TRM.

表 7-26. GPMC/NOR Flash Interface Switching Characteristics - Synchronous Mode - Default

NO.	PARAMETER	DESCRIPTION	MIN	MAX	UNIT
F0	$t_{c(\text{clk})}$	Cycle time, output clock gpmc_clk period	11.3		ns
F2	$t_{d(\text{clkH-nCSV})}$	Delay time, gpmc_clk rising edge to gpmc_cs[7:0] transition	F-1.48(6)	F+3.84(6)	ns
F3	$t_{d(\text{clkH-nCSIV})}$	Delay time, gpmc_clk rising edge to gpmc_cs[7:0] invalid	E-1.48(5)	E +3.84(5)	ns
F4	$t_{d(\text{ADDV-clk})}$	Delay time, gpmc_a[27:0] address bus valid to gpmc_clk first edge	B-1.69(2)	B+3.76(2)	ns
F5	$t_{d(\text{clkH-ADDIV})}$	Delay time, gpmc_clk rising edge to gpmc_a[27:0] gpmc address bus invalid	-1.69		ns
F6	$t_{d(\text{nBEV-clk})}$	Delay time, gpmc_ben[1:0] valid to gpmc_clk rising edge	B-3.8(2)	B+2.37(2)	ns
F7	$t_{d(\text{clkH-nBEIV})}$	Delay time, gpmc_clk rising edge to gpmc_ben[1:0] invalid	D-0.4(4)	D+1.1(4)	ns
F8	$t_{d(\text{clkH-nADV})}$	Delay time, gpmc_clk rising edge to gpmc_advn_ale transition	G-1.48 (7)	G+3.84 (7)	ns
F9	$t_{d(\text{clkH-nADVIV})}$	Delay time, gpmc_clk rising edge to gpmc_advn_ale invalid	D-1.48 (4)	G+3.84 (7)	ns
F10	$t_{d(\text{clkH-nOE})}$	Delay time, gpmc_clk rising edge to gpmc_oen_ren transition	H-1.41 (8)	H+2.45 (8)	ns
F11	$t_{d(\text{clkH-nOEIV})}$	Delay time, gpmc_clk rising edge to gpmc_oen_ren invalid	E-1.41 (5)	E+2.1 (5)	ns
F14	$t_{d(\text{clkH-nWE})}$	Delay time, gpmc_clk rising edge to gpmc_wen transition	I-1.18 (9)	I+3.68 (9)	ns
F15	$t_{d(\text{clkH-Data})}$	Delay time, gpmc_clk rising edge to gpmc_ad[15:0] data bus transition	J-1.89 (10)	J+4.89 (10)	ns
F17	$t_{d(\text{clkH-nBE})}$	Delay time, gpmc_clk rising edge to gpmc_ben[1:0] transition	J-1.3 (10)	J+3.8 (10)	ns
F18	$t_{w(\text{nCSV})}$	Pulse duration, gpmc_cs[7:0] low	A (1)		ns
F19	$t_{w(\text{nBEV})}$	Pulse duration, gpmc_ben[1:0] low	C (3)		ns
F20	$t_{w(\text{nADV})}$	Pulse duration, gpmc_advn_ale low	K (11)		ns
F23	$t_{d(\text{CLK-GPIO})}$	Delay time, gpmc_clk transition to gpio6_16.clkout1 transition	1.2	6.1	ns

表 7-27. GPMC/NOR Flash Interface Timing Requirements - Synchronous Mode - Alternate

NO.	PARAMETER	DESCRIPTION	MIN	MAX	UNIT
F12	$t_{su(\text{dV-clkH})}$	Setup time, read gpmc_ad[15:0] valid before gpmc_clk high	3.56		ns
F13	$t_{h(\text{clkH-dV})}$	Hold time, read gpmc_ad[15:0] valid after gpmc_clk high	1.9		ns
F21	$t_{su(\text{waitV-clkH})}$	Setup time, gpmc_wait[1:0] valid before gpmc_clk high	3.1		ns
F22	$t_{h(\text{clkH-waitV})}$	Hold Time, gpmc_wait[1:0] valid after gpmc_clk high	1.9		ns

表 7-28. GPMC/NOR Flash Interface Switching Characteristics - Synchronous Mode - Alternate

NO.	PARAMETER	DESCRIPTION	MIN	MAX	UNIT
F0	$t_{c(\text{clk})}$	Cycle time, output clock gpmc_clk period ⁽¹²⁾	15.04		ns
F2	$t_{d(\text{clkH-nCSV})}$	Delay time, gpmc_clk rising edge to gpmc_cs[7:0] transition	F-0.84 (6)	F+6.73 (6)	ns
F3	$t_{d(\text{clkH-nCSIV})}$	Delay time, gpmc_clk rising edge to gpmc_cs[7:0] invalid	E-0.84 (5)	E+6.73 (5)	ns
F4	$t_{d(\text{ADDV-clk})}$	Delay time, gpmc_a[27:0] address bus valid to gpmc_clk first edge	B-1.36 (2)	B+6.73 (2)	ns
F5	$t_{d(\text{clkH-ADDIV})}$	Delay time, gpmc_clk rising edge to gpmc_a[27:0] gpmc address bus invalid	-1.36		ns
F6	$t_{d(\text{nBEV-clk})}$	Delay time, gpmc_ben[1:0] valid to gpmc_clk rising edge	B-6.34 (2)	B+0.6 (2)	ns
F7	$t_{d(\text{clkH-nBEIV})}$	Delay time, gpmc_clk rising edge to gpmc_ben[1:0] invalid	D-0.4 (4)	D+4.9 (4)	ns

表 7-28. GPMC/NOR Flash Interface Switching Characteristics - Synchronous Mode - Alternate (continued)

NO.	PARAMETER	DESCRIPTION	MIN	MAX	UNIT
F8	$t_{d(\text{clkH-nADV})}$	Delay time, gpmc_clk rising edge to gpmc_advn_ale transition	G-0.67 (7)	G+6.1 (7)	ns
F9	$t_{d(\text{clkH-nADVIV})}$	Delay time, gpmc_clk rising edge to gpmc_advn_ale invalid	D-0.67 (4)	D+6.1 (4)	ns
F10	$t_{d(\text{clkH-nOE})}$	Delay time, gpmc_clk rising edge to gpmc_oen_ren transition	H-0.67 (8)	H+5.65 (8)	ns
F11	$t_{d(\text{clkH-nOEIV})}$	Delay time, gpmc_clk rising edge to gpmc_oen_ren invalid	E-0.67 (5)	E+5.65 (5)	ns
F14	$t_{d(\text{clkH-nWE})}$	Delay time, gpmc_clk rising edge to gpmc_wen transition	I-0.6 (9)	I+6.1 (9)	ns
F15	$t_{d(\text{clkH-Data})}$	Delay time, gpmc_clk rising edge to gpmc_ad[15:0] data bus transition	J-1.76 (10)	J+6.39 (10)	ns
F17	$t_{d(\text{clkH-nBE})}$	Delay time, gpmc_clk rising edge to gpmc_ben[1:0] transition	J-0.6 (10)	J+6.34 (10)	ns
F18	$t_{w(nCSV)}$	Pulse duration, gpmc_cs[7:0] low	A (10)		ns
F19	$t_{w(nBEV)}$	Pulse duration, gpmc_ben[1:0] low	C (3)		ns
F20	$t_{w(nADV)}$	Pulse duration, gpmc_advn_ale low	K (11)		ns
F23	$t_{d(\text{CLK-GPIO})}$	Delay time, gpmc_clk transition to gpio6_16.clkout1 transition ⁽¹³⁾	0.96	6.1	ns

- (1) For single read: $A = (\text{CSRdOffTime} - \text{CSOnTime}) * (\text{TimeParaGranularity} + 1) * \text{GPMC_FCLK period}$
 For burst read: $A = (\text{CSRdOffTime} - \text{CSOnTime} + (n - 1) * \text{PageBurstAccessTime}) * (\text{TimeParaGranularity} + 1) * \text{GPMC_FCLK period}$
 For burst write: $A = (\text{CSWrOffTime} - \text{CSOnTime} + (n - 1) * \text{PageBurstAccessTime}) * (\text{TimeParaGranularity} + 1) * \text{GPMC_FCLK period}$
 with n the page burst access number.
- (2) $B = \text{ClkActivationTime} * \text{GPMC_FCLK}$
- (3) For single read: $C = \text{RdCycleTime} * (\text{TimeParaGranularity} + 1) * \text{GPMC_FCLK}$
 For burst read: $C = (\text{RdCycleTime} + (n - 1) * \text{PageBurstAccessTime}) * (\text{TimeParaGranularity} + 1) * \text{GPMC_FCLK}$
 For Burst write: $C = (\text{WrCycleTime} + (n - 1) * \text{PageBurstAccessTime}) * (\text{TimeParaGranularity} + 1) * \text{GPMC_FCLK}$ with n the page burst access number.
- (4) For single read: $D = (\text{RdCycleTime} - \text{AccessTime}) * (\text{TimeParaGranularity} + 1) * \text{GPMC_FCLK}$
 For burst read: $D = (\text{RdCycleTime} - \text{AccessTime}) * (\text{TimeParaGranularity} + 1) * \text{GPMC_FCLK}$
 For burst write: $D = (\text{WrCycleTime} - \text{AccessTime}) * (\text{TimeParaGranularity} + 1) * \text{GPMC_FCLK}$
- (5) For single read: $E = (\text{CSRdOffTime} - \text{AccessTime}) * (\text{TimeParaGranularity} + 1) * \text{GPMC_FCLK}$
 For burst read: $E = (\text{CSRdOffTime} - \text{AccessTime}) * (\text{TimeParaGranularity} + 1) * \text{GPMC_FCLK}$
 For burst write: $E = (\text{CSWrOffTime} - \text{AccessTime}) * (\text{TimeParaGranularity} + 1) * \text{GPMC_FCLK}$
- (6) For nCS falling edge (CS activated):
 Case GpmcFCLKDivider = 0 :
 $F = 0.5 * \text{CSExtraDelay} * \text{GPMC_FCLK}$ Case GpmcFCLKDivider = 1:
 $F = 0.5 * \text{CSExtraDelay} * \text{GPMC_FCLK}$ if (ClkActivationTime and CSOnTime are odd) or (ClkActivationTime and CSOnTime are even)
 $F = (1 + 0.5 * \text{CSExtraDelay}) * \text{GPMC_FCLK}$ otherwise
 Case GpmcFCLKDivider = 2:
 $F = 0.5 * \text{CSExtraDelay} * \text{GPMC_FCLK}$ if ((CSOnTime - ClkActivationTime) is a multiple of 3)
 $F = (1 + 0.5 * \text{CSExtraDelay}) * \text{GPMC_FCLK}$ if ((CSOnTime - ClkActivationTime - 1) is a multiple of 3)
 $F = (2 + 0.5 * \text{CSExtraDelay}) * \text{GPMC_FCLK}$ if ((CSOnTime - ClkActivationTime - 2) is a multiple of 3)
 Case GpmcFCLKDivider = 3:
 $F = 0.5 * \text{CSExtraDelay} * \text{GPMC_FCLK}$ if ((CSOnTime - ClkActivationTime) is a multiple of 4)
 $F = (1 + 0.5 * \text{CSExtraDelay}) * \text{GPMC_FCLK}$ if ((CSOnTime - ClkActivationTime - 1) is a multiple of 4)
 $F = (2 + 0.5 * \text{CSExtraDelay}) * \text{GPMC_FCLK}$ if ((CSOnTime - ClkActivationTime - 2) is a multiple of 4)
 $F = (3 + 0.5 * \text{CSExtraDelay}) * \text{GPMC_FCLK}$ if ((CSOnTime - ClkActivationTime - 3) is a multiple of 4)
- (7) For ADV falling edge (ADV activated):
 Case GpmcFCLKDivider = 0 :
 $G = 0.5 * \text{ADVExtraDelay} * \text{GPMC_FCLK}$
 Case GpmcFCLKDivider = 1:
 $G = 0.5 * \text{ADVExtraDelay} * \text{GPMC_FCLK}$ if (ClkActivationTime and ADVOnTime are odd) or (ClkActivationTime and ADVOnTime are even)
 $G = (1 + 0.5 * \text{ADVExtraDelay}) * \text{GPMC_FCLK}$ otherwise
 Case GpmcFCLKDivider = 2:

$G = 0.5 * ADVExtraDelay * GPMC_FCLK$ if ((ADVOnTime – ClkActivationTime) is a multiple of 3)

$G = (1 + 0.5 * ADVExtraDelay) * GPMC_FCLK$ if ((ADVOnTime – ClkActivationTime – 1) is a multiple of 3)

$G = (2 + 0.5 * ADVExtraDelay) * GPMC_FCLK$ if ((ADVOnTime – ClkActivationTime – 2) is a multiple of 3)

For ADV rising edge (ADV deactivated) in Reading mode:

Case GpmcFCLKDivider = 0:

$G = 0.5 * ADVExtraDelay * GPMC_FCLK$

Case GpmcFCLKDivider = 1:

$G = 0.5 * ADVExtraDelay * GPMC_FCLK$ if (ClkActivationTime and ADVRdOffTime are odd) or (ClkActivationTime and ADVRdOffTime are even)

$G = (1 + 0.5 * ADVExtraDelay) * GPMC_FCLK$ otherwise

Case GpmcFCLKDivider = 2:

$G = 0.5 * ADVExtraDelay * GPMC_FCLK$ if ((ADVRdOffTime – ClkActivationTime) is a multiple of 3)

$G = (1 + 0.5 * ADVExtraDelay) * GPMC_FCLK$ if ((ADVRdOffTime – ClkActivationTime – 1) is a multiple of 3)

$G = (2 + 0.5 * ADVExtraDelay) * GPMC_FCLK$ if ((ADVRdOffTime – ClkActivationTime – 2) is a multiple of 3)

Case GpmcFCLKDivider = 3:

$G = 0.5 * ADVExtraDelay * GPMC_FCLK$ if ((ADVRdOffTime – ClkActivationTime) is a multiple of 4)

$G = (1 + 0.5 * ADVExtraDelay) * GPMC_FCLK$ if ((ADVRdOffTime – ClkActivationTime – 1) is a multiple of 4)

$G = (2 + 0.5 * ADVExtraDelay) * GPMC_FCLK$ if ((ADVRdOffTime – ClkActivationTime – 2) is a multiple of 4)

$G = (3 + 0.5 * ADVExtraDelay) * GPMC_FCLK$ if ((ADVRdOffTime – ClkActivationTime – 3) is a multiple of 4)

For ADV rising edge (ADV deactivated) in Writing mode:

Case GpmcFCLKDivider = 0:

$G = 0.5 * ADVExtraDelay * GPMC_FCLK$

Case GpmcFCLKDivider = 1:

$G = 0.5 * ADVExtraDelay * GPMC_FCLK$ if (ClkActivationTime and ADVWrOffTime are odd) or (ClkActivationTime and ADVWrOffTime are even)

$G = (1 + 0.5 * ADVExtraDelay) * GPMC_FCLK$ otherwise

Case GpmcFCLKDivider = 2:

$G = 0.5 * ADVExtraDelay * GPMC_FCLK$ if ((ADVWrOffTime – ClkActivationTime) is a multiple of 3)

$G = (1 + 0.5 * ADVExtraDelay) * GPMC_FCLK$ if ((ADVWrOffTime – ClkActivationTime – 1) is a multiple of 3)

$G = (2 + 0.5 * ADVExtraDelay) * GPMC_FCLK$ if ((ADVWrOffTime – ClkActivationTime – 2) is a multiple of 3)

Case GpmcFCLKDivider = 3:

$G = 0.5 * ADVExtraDelay * GPMC_FCLK$ if ((ADVWrOffTime – ClkActivationTime) is a multiple of 4)

$G = (1 + 0.5 * ADVExtraDelay) * GPMC_FCLK$ if ((ADVWrOffTime – ClkActivationTime – 1) is a multiple of 4)

$G = (2 + 0.5 * ADVExtraDelay) * GPMC_FCLK$ if ((ADVWrOffTime – ClkActivationTime – 2) is a multiple of 4)

$G = (3 + 0.5 * ADVExtraDelay) * GPMC_FCLK$ if ((ADVWrOffTime – ClkActivationTime – 3) is a multiple of 4)

(8) For OE falling edge (OE activated):

Case GpmcFCLKDivider = 0:

$H = 0.5 * OEEExtraDelay * GPMC_FCLK$

Case GpmcFCLKDivider = 1:

$H = 0.5 * OEEExtraDelay * GPMC_FCLK$ if (ClkActivationTime and OEOnTime are odd) or (ClkActivationTime and OEOnTime are even)

$H = (1 + 0.5 * OEEExtraDelay) * GPMC_FCLK$ otherwise

Case GpmcFCLKDivider = 2:

$H = 0.5 * OEEExtraDelay * GPMC_FCLK$ if ((OEOnTime – ClkActivationTime) is a multiple of 3)

$H = (1 + 0.5 * OEEExtraDelay) * GPMC_FCLK$ if ((OEOnTime – ClkActivationTime – 1) is a multiple of 3)

$H = (2 + 0.5 * OEEExtraDelay) * GPMC_FCLK$ if ((OEOnTime – ClkActivationTime – 2) is a multiple of 3)

Case GpmcFCLKDivider = 3:

$H = 0.5 * OEEExtraDelay * GPMC_FCLK$ if ((OEOnTime – ClkActivationTime) is a multiple of 4)

$H = (1 + 0.5 * OEEExtraDelay) * GPMC_FCLK$ if ((OEOnTime – ClkActivationTime – 1) is a multiple of 4)

$H = (2 + 0.5 * OEEExtraDelay) * GPMC_FCLK$ if ((OEOnTime – ClkActivationTime – 2) is a multiple of 4)

$H = (3 + 0.5 * OEEExtraDelay) * GPMC_FCLK$ if ((OEOnTime – ClkActivationTime – 3) is a multiple of 4)

For OE rising edge (OE deactivated):

Case GpmcFCLKDivider = 0:

$H = 0.5 * OEEExtraDelay * GPMC_FCLK$

Case GpmcFCLKDivider = 1:

$H = 0.5 * OEEExtraDelay * GPMC_FCLK$ if (ClkActivationTime and OEOffTime are odd) or (ClkActivationTime and OEOffTime are even)

$H = (1 + 0.5 * OEEExtraDelay) * GPMC_FCLK$ otherwise

Case GpmcFCLKDivider = 2:

- $H = 0.5 * OEEExtraDelay * GPMC_FCLK$ if $((OEOffTime - ClkActivationTime)$ is a multiple of 3)
- $H = (1 + 0.5 * OEEExtraDelay) * GPMC_FCLK$ if $((OEOffTime - ClkActivationTime - 1)$ is a multiple of 3)
- $H = (2 + 0.5 * OEEExtraDelay) * GPMC_FCLK$ if $((OEOffTime - ClkActivationTime - 2)$ is a multiple of 3)
- Case $GpmcFCLKDivider = 3$:
- $H = 0.5 * OEEExtraDelay * GPMC_FCLK$ if $((OEOffTime - ClkActivationTime)$ is a multiple of 4)
- $H = (1 + 0.5 * OEEExtraDelay) * GPMC_FCLK$ if $((OEOffTime - ClkActivationTime - 1)$ is a multiple of 4)
- $H = (2 + 0.5 * OEEExtraDelay) * GPMC_FCLK$ if $((OEOffTime - ClkActivationTime - 2)$ is a multiple of 4)
- $H = (3 + 0.5 * OEEExtraDelay) * GPMC_FCLK$ if $((OEOffTime - ClkActivationTime - 3)$ is a multiple of 4)

(9) For WE falling edge (WE activated):

- Case $GpmcFCLKDivider = 0$:
- $I = 0.5 * WEExtraDelay * GPMC_FCLK$
- Case $GpmcFCLKDivider = 1$:
- $I = 0.5 * WEExtraDelay * GPMC_FCLK$ if $(ClkActivationTime$ and $WEOnTime$ are odd) or $(ClkActivationTime$ and $WEOnTime$ are even)
- $I = (1 + 0.5 * WEExtraDelay) * GPMC_FCLK$ otherwise
- Case $GpmcFCLKDivider = 2$:
- $I = 0.5 * WEExtraDelay * GPMC_FCLK$ if $((WEOnTime - ClkActivationTime)$ is a multiple of 3)
- $I = (1 + 0.5 * WEExtraDelay) * GPMC_FCLK$ if $((WEOnTime - ClkActivationTime - 1)$ is a multiple of 3)
- $I = (2 + 0.5 * WEExtraDelay) * GPMC_FCLK$ if $((WEOnTime - ClkActivationTime - 2)$ is a multiple of 3)
- Case $GpmcFCLKDivider = 3$:
- $I = 0.5 * WEExtraDelay * GPMC_FCLK$ if $((WEOnTime - ClkActivationTime)$ is a multiple of 4)
- $I = (1 + 0.5 * WEExtraDelay) * GPMC_FCLK$ if $((WEOnTime - ClkActivationTime - 1)$ is a multiple of 4)
- $I = (2 + 0.5 * WEExtraDelay) * GPMC_FCLK$ if $((WEOnTime - ClkActivationTime - 2)$ is a multiple of 4)
- $I = (3 + 0.5 * WEExtraDelay) * GPMC_FCLK$ if $((WEOnTime - ClkActivationTime - 3)$ is a multiple of 4)

For WE rising edge (WE deactivated):

- Case $GpmcFCLKDivider = 0$:
- $I = 0.5 * WEExtraDelay * GPMC_FCLK$
- Case $GpmcFCLKDivider = 1$:
- $I = 0.5 * WEExtraDelay * GPMC_FCLK$ if $(ClkActivationTime$ and $WEOffTime$ are odd) or $(ClkActivationTime$ and $WEOffTime$ are even)
- $I = (1 + 0.5 * WEExtraDelay) * GPMC_FCLK$ otherwise
- Case $GpmcFCLKDivider = 2$:
- $I = 0.5 * WEExtraDelay * GPMC_FCLK$ if $((WEOffTime - ClkActivationTime)$ is a multiple of 3)
- $I = (1 + 0.5 * WEExtraDelay) * GPMC_FCLK$ if $((WEOffTime - ClkActivationTime - 1)$ is a multiple of 3)
- $I = (2 + 0.5 * WEExtraDelay) * GPMC_FCLK$ if $((WEOffTime - ClkActivationTime - 2)$ is a multiple of 3)
- Case $GpmcFCLKDivider = 3$:
- $I = 0.5 * WEExtraDelay * GPMC_FCLK$ if $((WEOffTime - ClkActivationTime)$ is a multiple of 4)
- $I = (1 + 0.5 * WEExtraDelay) * GPMC_FCLK$ if $((WEOffTime - ClkActivationTime - 1)$ is a multiple of 4)
- $I = (2 + 0.5 * WEExtraDelay) * GPMC_FCLK$ if $((WEOffTime - ClkActivationTime - 2)$ is a multiple of 4)
- $I = (3 + 0.5 * WEExtraDelay) * GPMC_FCLK$ if $((WEOffTime - ClkActivationTime - 3)$ is a multiple of 4)

(10) $J = GPMC_FCLK$ period, where $GPMC_FCLK$ is the General Purpose Memory Controller internal functional clock

(11) For read:

$$K = (ADVRdOffTime - ADVOnTime) * (TimeParaGranularity + 1) * GPMC_FCLK$$

For write: $K = (ADVWrOffTime - ADVOnTime) * (TimeParaGranularity + 1) * GPMC_FCLK$

(12) The $gpmc_clk$ output clock maximum and minimum frequency is programmable in the I/F module by setting the $GPMC_CONFIG1_CSx$ configuration register bit fields $GpmcFCLKDivider$

(13) $gpio6_16$ programmed to $MUXMODE=9$ (clkout1), $CM_CLKSEL_CLKOUTMUX1$ programmed to 7 (CORE_DPLL_OUT_DCLK), $CM_CLKSEL_CORE_DPLL_OUT_CLK_CLKOUTMUX$ programmed to 1.

(14) $CSEXTRADELAY = 0$, $ADVEXTRADELAY = 0$, $WEEXTRADELAY = 0$, $OEXTRADELAY = 0$. Extra half- $GPMC_FCLK$ cycle delay mode is not timed.

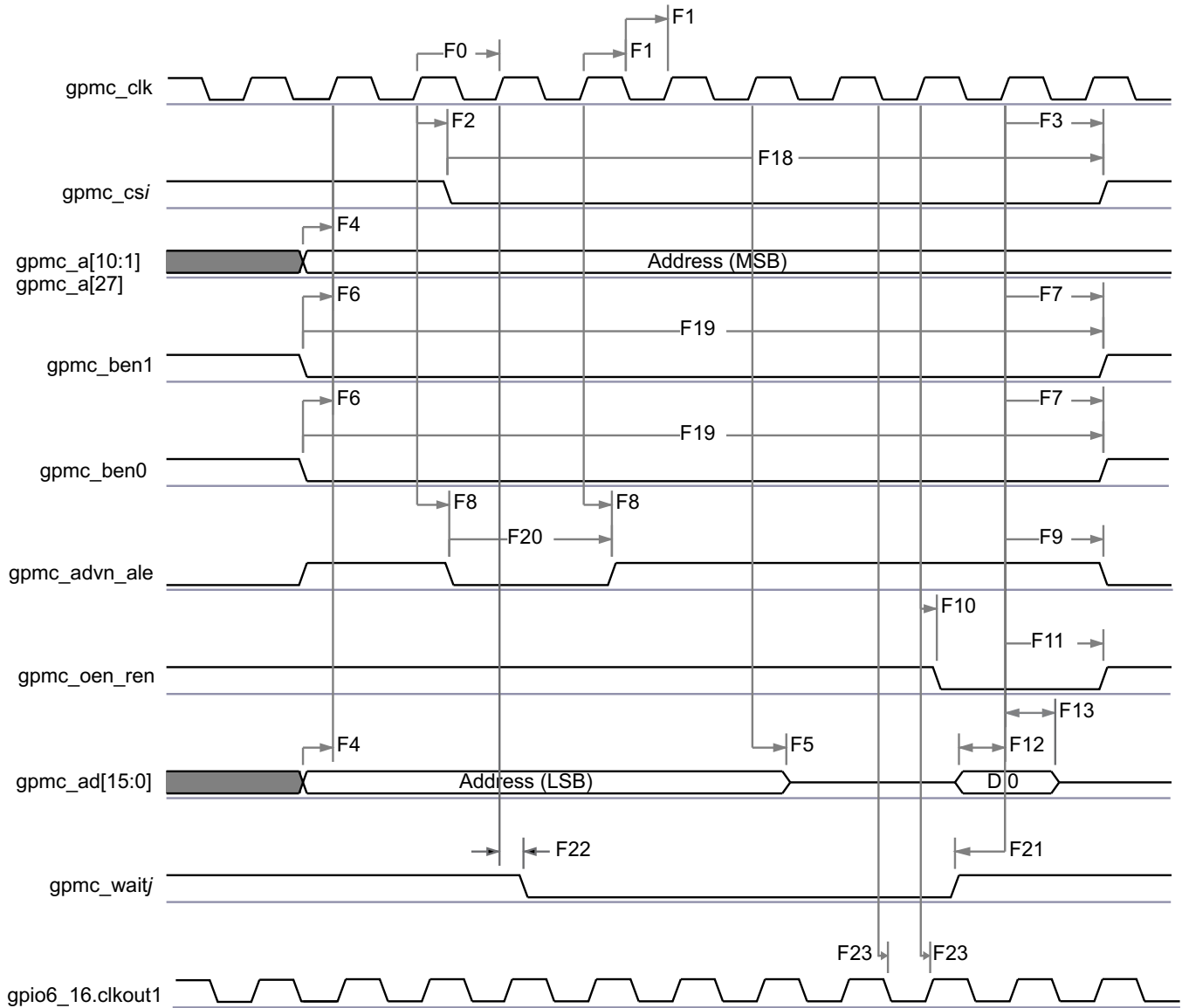

GPMC_01

7-7. GPMC / Multiplexed 16bits NOR Flash - Synchronous Single Read - (GpmcFCLKDivider = 0)⁽¹⁾⁽²⁾

(1) In gpmc_csi, i = 0 to 7.

(2) In gpmc_waitj, j = 0 to 1.



图 7-8. GPMC / Nonmultiplexed 16bits NOR Flash - Synchronous Single Read -
 (GpmcFCLKDivider = 0)⁽¹⁾⁽²⁾

- (1) In gpmc_csi, i = 0 to 7.
- (2) In gpmc_waitj, j = 0 to 1.

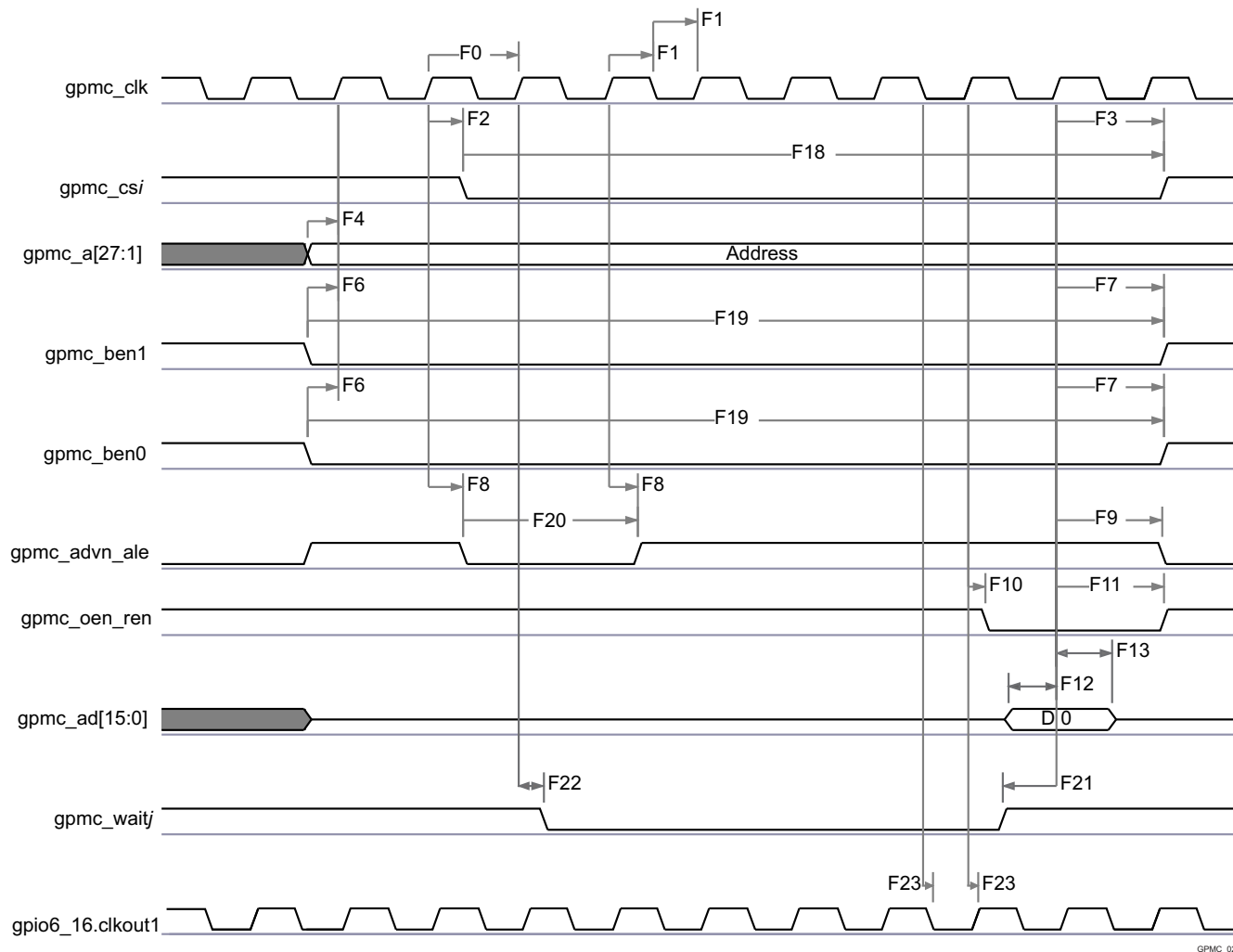
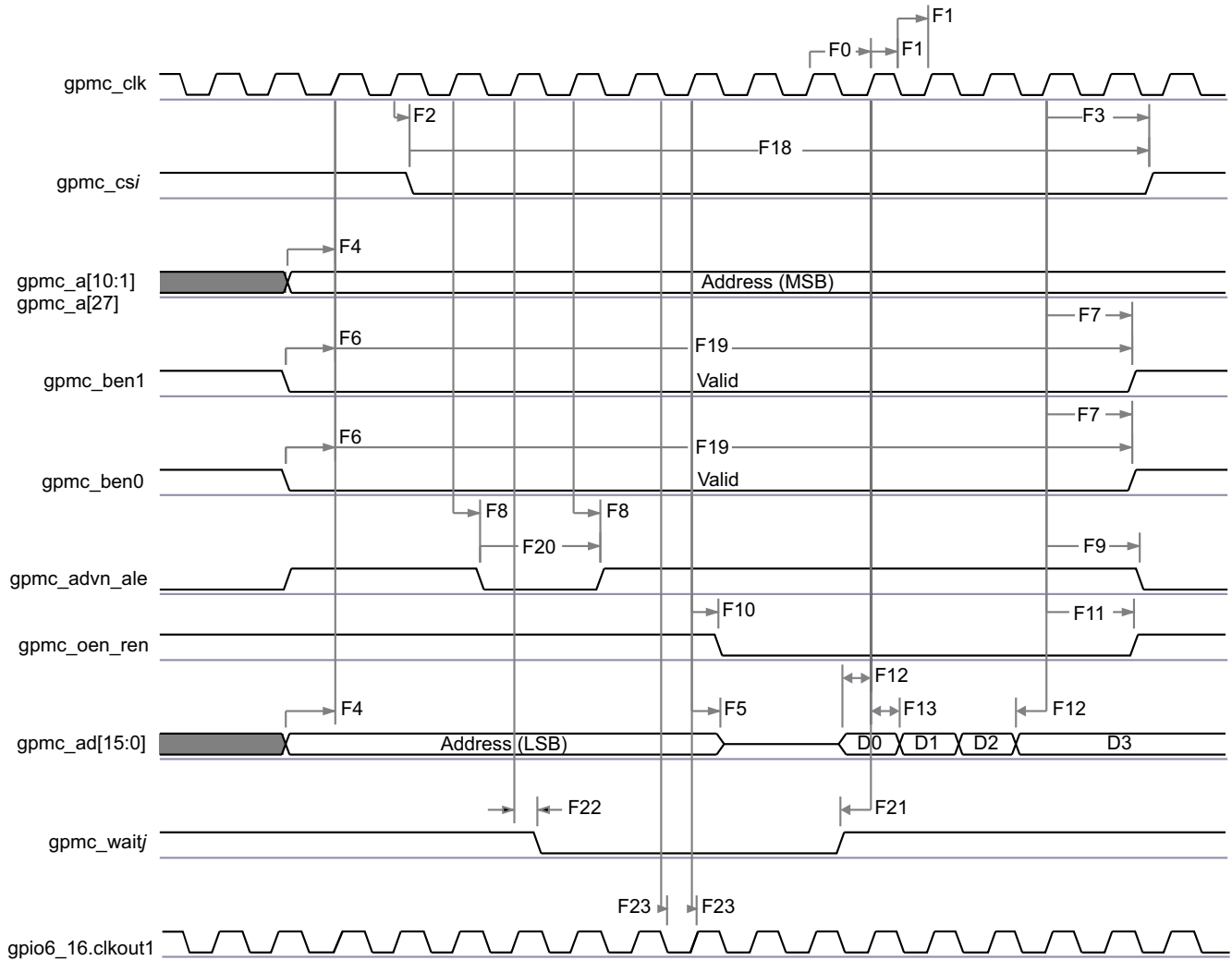

GPMC_03

7-9. GPMC / Multiplexed 16bits NOR Flash - Synchronous Burst Read 4x16 bits - (GpmcFCLKDivider = 0)⁽¹⁾⁽²⁾

- (1) In gpmc_csi, i = 0 to 7.
- (2) In gpmc_waitj, j = 0 to 1.

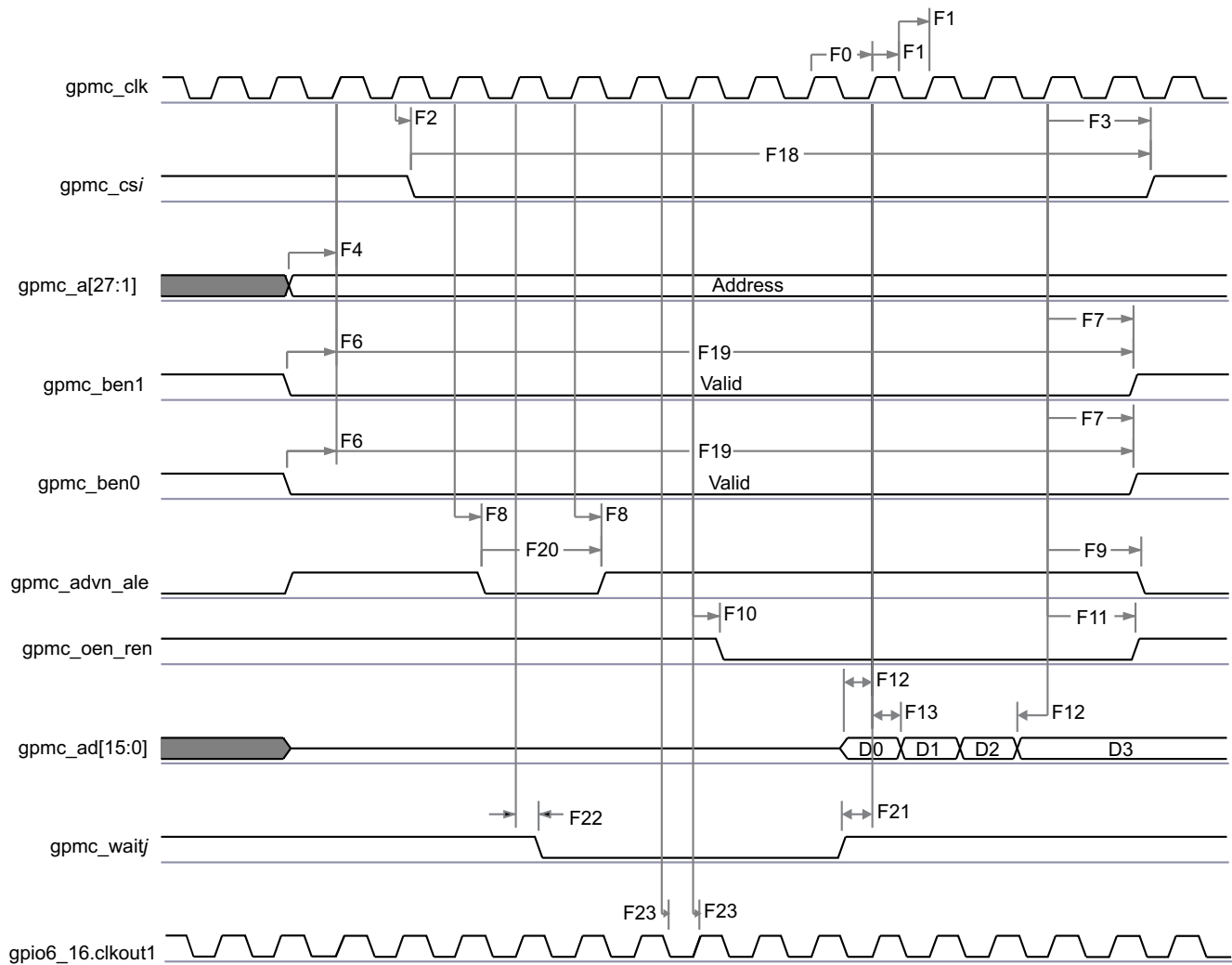

GPMC_04

图 7-10. GPMC / Nonmultiplexed 16bits NOR Flash - Synchronous Burst Read 4x16 bits - (GpmcFCLKDivider = 0)⁽¹⁾⁽²⁾

- (1) In gpmc_csi, i = 0 to 7.
- (2) In gpmc_waitj, j = 0 to 1.

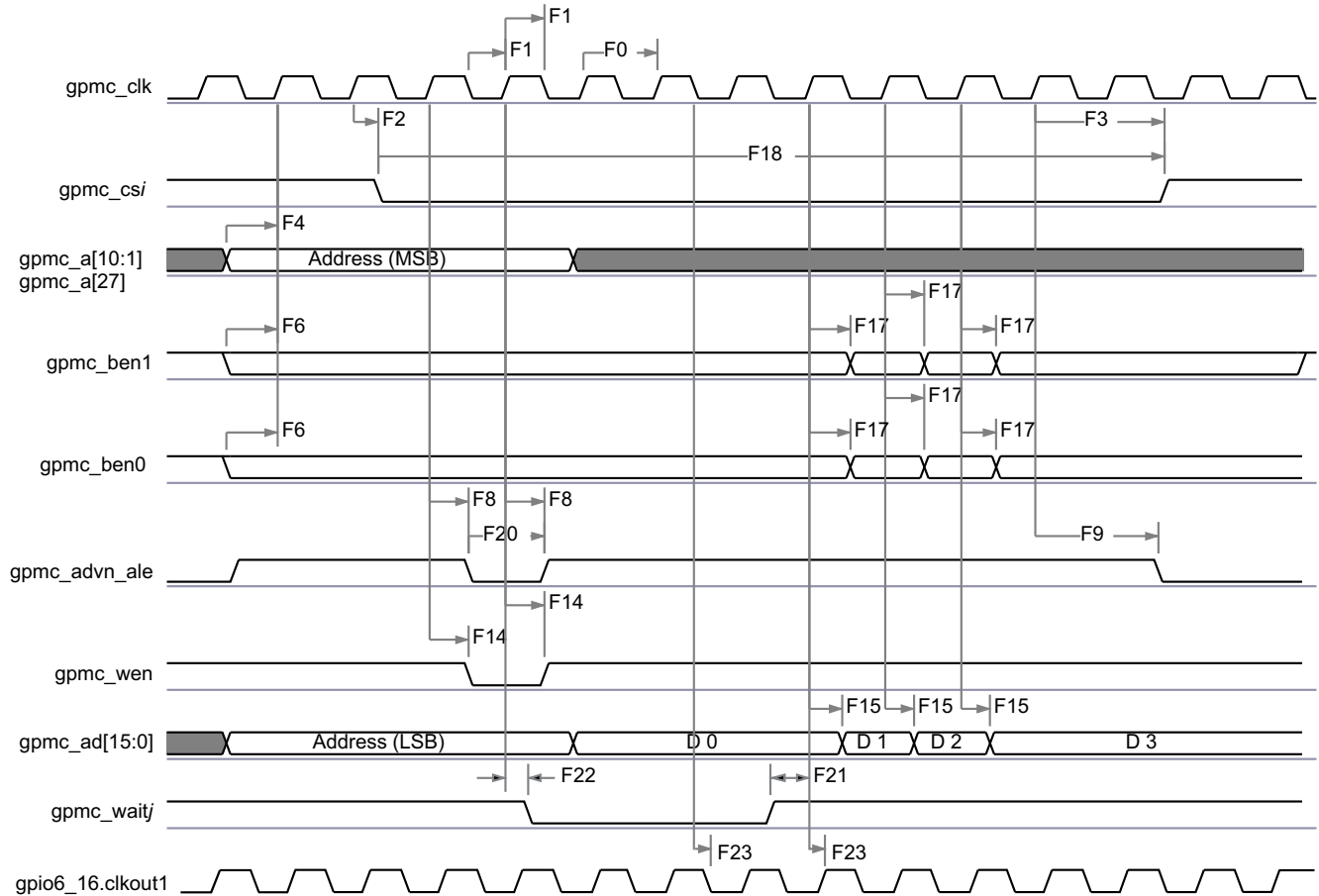

GPMC_05

图 7-11. GPMC / Multiplexed 16bits NOR Flash - Synchronous Burst Write 4x16bits -
(GpmcFCLKDivider = 0)⁽¹⁾⁽²⁾

- (1) In gpmc_csi, i = 0 to 7.
- (2) In gpmc_waitj, j = 0 to 1.

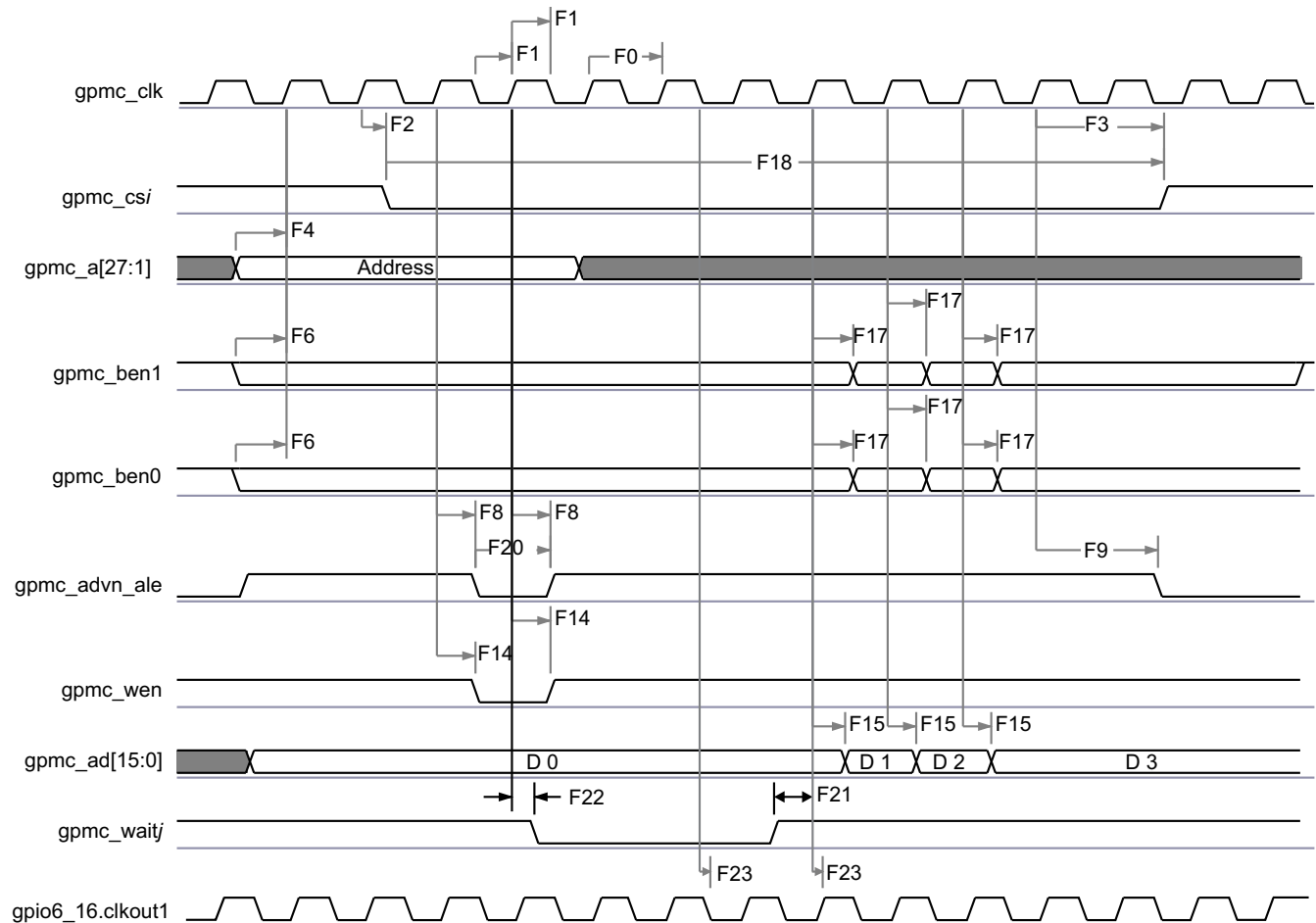

GPMC_06

图 7-12. GPMC / Nonmultiplexed 16bits NOR Flash - Synchronous Burst Write 4x16bits - (GpmcFCLKDivider = 0)⁽¹⁾⁽²⁾

- (1) In gpmc_csi, i = 1 to 7.
- (2) In gpmc_waitj, j = 0 to 1.

7.10.2 GPMC/NOR Flash Interface Asynchronous Timing

注意

The IO Timings provided in this section are only valid for some GPMC usage modes when the corresponding Virtual IO Timings or Manual IO Timings are configured as described in the tables found in this section.

表 7-29 和 表 7-30 assume testing over the recommended operating conditions and electrical characteristic conditions below (see 图 7-13, 图 7-14, 图 7-15, 图 7-16, 图 7-17, and 图 7-18).

表 7-29. GPMC/NOR Flash Interface Timing Requirements - Asynchronous Mode

NO.	PARAMETER	DESCRIPTION	MIN	MAX	UNIT
FA5	t _{acc(DAT)}	Data Maximum Access Time (GPMC_FCLK cycles)		H ⁽¹⁾	cycles
FA20	t _{acc1-pgmode(DAT)}	Page Mode Successive Data Maximum Access Time (GPMC_FCLK cycles)		P ⁽²⁾	cycles
FA21	t _{acc2-pgmode(DAT)}	Page Mode First Data Maximum Access Time (GPMC_FCLK cycles)		H ⁽¹⁾	cycles

表 7-29. GPMC/NOR Flash Interface Timing Requirements - Asynchronous Mode (continued)

NO.	PARAMETER	DESCRIPTION	MIN	MAX	UNIT
-	$t_{su}(DV-OEH)$	Setup time, read gpmc_ad[15:0] valid before gpmc_oen_ren high	1.9		ns
-	$t_h(OEH-DV)$	Hold time, read gpmc_ad[15:0] valid after gpmc_oen_ren high	1		ns

(1) $H = \text{Access Time} * (\text{TimeParaGranularity} + 1)$

(2) $P = \text{PageBurstAccessTime} * (\text{TimeParaGranularity} + 1)$
表 7-30. GPMC/NOR Flash Interface Switching Characteristics - Asynchronous Mode

NO.	PARAMETER	DESCRIPTION	MIN	MAX	UNIT
-	$t_{r}(DO)$	Rising time, gpmc_ad[15:0] output data	0.447	4.067	ns
-	$t_{f}(DO)$	Falling time, gpmc_ad[15:0] output data	0.43	4.463	ns
FA0	$t_{w}(nBEV)$	Pulse duration, gpmc_ben[1:0] valid time		N ⁽¹⁾	ns
FA1	$t_{w}(nCSV)$	Pulse duration, gpmc_cs[7:0] low		A ⁽²⁾	ns
FA3	$t_{d}(nCSV-nADVIV)$	Delay time, gpmc_cs[7:0] valid to gpmc_advn_ale invalid	B - 2 ⁽³⁾	B + 4 ⁽³⁾	ns
FA4	$t_{d}(nCSV-nOEIV)$	Delay time, gpmc_cs[7:0] valid to gpmc_oen_ren invalid (Single read)	C - 2 ⁽⁴⁾	C + 4 ⁽⁴⁾	ns
FA9	$t_{d}(AV-nCSV)$	Delay time, address bus valid to gpmc_cs[7:0] valid	J - 2 ⁽⁵⁾	J + 4 ⁽⁵⁾	ns
FA10	$t_{d}(nBEV-nCSV)$	Delay time, gpmc_ben[1:0] valid to gpmc_cs[7:0] valid	J - 2 ⁽⁵⁾	J + 4 ⁽⁵⁾	ns
FA12	$t_{d}(nCSV-nADVIV)$	Delay time, gpmc_cs[7:0] valid to gpmc_advn_ale valid	K - 2 ⁽⁶⁾	K + 4 ⁽⁶⁾	ns
FA13	$t_{d}(nCSV-nOEIV)$	Delay time, gpmc_cs[7:0] valid to gpmc_oen_ren valid	L - 2 ⁽⁷⁾	L + 4 ⁽⁷⁾	ns
FA16	$t_{w}(AIV)$	Pulse duration, address invalid between 2 successive R/W accesses	G ⁽⁸⁾		ns
FA18	$t_{d}(nCSV-nOEIV)$	Delay time, gpmc_cs[7:0] valid to gpmc_oen_ren invalid (Burst read)	I - 2 ⁽⁹⁾	I + 4 ⁽⁹⁾	ns
FA20	$t_{w}(AV)$	Pulse duration, address valid : 2nd, 3rd and 4th accesses	D ⁽¹⁰⁾		ns
FA25	$t_{d}(nCSV-nWEV)$	Delay time, gpmc_cs[7:0] valid to gpmc_wen valid	E - 2 ⁽¹¹⁾	E + 4 ⁽¹¹⁾	ns
FA27	$t_{d}(nCSV-nWEIV)$	Delay time, gpmc_cs[7:0] valid to gpmc_wen invalid	F - 2 ⁽¹²⁾	F + 4 ⁽¹²⁾	ns
FA28	$t_{d}(nWEV-DV)$	Delay time, gpmc_wen valid to data bus valid		2	ns
FA29	$t_{d}(DV-nCSV)$	Delay time, data bus valid to gpmc_cs[7:0] valid	J - 2 ⁽⁵⁾	J + 4 ⁽⁵⁾	ns
FA37	$t_{d}(nOEIV-AIV)$	Delay time, gpmc_oen_ren valid to gpmc_ad[15:0] multiplexed address bus phase end		2	ns

(1) For single read: $N = \text{RdCycleTime} * (\text{TimeParaGranularity} + 1) * \text{GPMC_FCLK}$

For single write: $N = \text{WrCycleTime} * (\text{TimeParaGranularity} + 1) * \text{GPMC_FCLK}$

For burst read: $N = (\text{RdCycleTime} + (n - 1) * \text{PageBurstAccessTime}) * (\text{TimeParaGranularity} + 1) * \text{GPMC_FCLK}$

For burst write: $N = (\text{WrCycleTime} + (n - 1) * \text{PageBurstAccessTime}) * (\text{TimeParaGranularity} + 1) * \text{GPMC_FCLK}$

(2) For single read: $A = (\text{CSRdOffTime} - \text{CSONTime}) * (\text{TimeParaGranularity} + 1) * \text{GPMC_FCLK}$

For single write: $A = (\text{CSWrOffTime} - \text{CSONTime}) * (\text{TimeParaGranularity} + 1) * \text{GPMC_FCLK}$

For burst read: $A = (\text{CSRdOffTime} - \text{CSONTime} + (n - 1) * \text{PageBurstAccessTime}) * (\text{TimeParaGranularity} + 1) * \text{GPMC_FCLK}$

For burst write: $A = (\text{CSWrOffTime} - \text{CSONTime} + (n - 1) * \text{PageBurstAccessTime}) * (\text{TimeParaGranularity} + 1) * \text{GPMC_FCLK}$

(3) For reading: $B = ((\text{ADVrdOffTime} - \text{CSONTime}) * (\text{TimeParaGranularity} + 1) + 0.5 * (\text{ADVExtraDelay} - \text{CSEExtraDelay})) * \text{GPMC_FCLK}$

For writing: $B = ((\text{ADVWrOffTime} - \text{CSONTime}) * (\text{TimeParaGranularity} + 1) + 0.5 * (\text{ADVExtraDelay} - \text{CSEExtraDelay})) * \text{GPMC_FCLK}$

(4) $C = ((\text{OEOffTime} - \text{CSONTime}) * (\text{TimeParaGranularity} + 1) + 0.5 * (\text{OEExtraDelay} - \text{CSEExtraDelay})) * \text{GPMC_FCLK}$

(5) $J = (\text{CSONTime} * (\text{TimeParaGranularity} + 1) + 0.5 * \text{CSEExtraDelay}) * \text{GPMC_FCLK}$

(6) $K = ((\text{ADVOnTime} - \text{CSONTime}) * (\text{TimeParaGranularity} + 1) + 0.5 * (\text{ADVExtraDelay} - \text{CSEExtraDelay})) * \text{GPMC_FCLK}$

(7) $L = ((\text{OEOnTime} - \text{CSONTime}) * (\text{TimeParaGranularity} + 1) + 0.5 * (\text{OEExtraDelay} - \text{CSEExtraDelay})) * \text{GPMC_FCLK}$

(8) $G = \text{Cycle2CycleDelay} * \text{GPMC_FCLK} * (\text{TimeParaGranularity} + 1)$

(9) $I = ((\text{OEOffTime} + (n - 1) * \text{PageBurstAccessTime} - \text{CSONTime}) * (\text{TimeParaGranularity} + 1) + 0.5 * (\text{OEExtraDelay} - \text{CSEExtraDelay})) * \text{GPMC_FCLK}$

(10) $D = \text{PageBurstAccessTime} * (\text{TimeParaGranularity} + 1) * \text{GPMC_FCLK}$

(11) $E = ((\text{WEOnTime} - \text{CSONTime}) * (\text{TimeParaGranularity} + 1) + 0.5 * (\text{WEExtraDelay} - \text{CSEExtraDelay})) * \text{GPMC_FCLK}$

(12) $F = ((\text{WEOffTime} - \text{CSONTime}) * (\text{TimeParaGranularity} + 1) + 0.5 * (\text{WEExtraDelay} - \text{CSEExtraDelay})) * \text{GPMC_FCLK}$



图 7-13. GPMC / NOR Flash - Asynchronous Read - Single Word Timing⁽¹⁾⁽²⁾⁽³⁾⁽⁴⁾

- (1) In $gpmc_csi$, $i = 0$ to 7. In $gpmc_waitj$, $j = 0$ to 1.
- (2) FA5 parameter illustrates amount of time required to internally sample input data. It is expressed in number of GPMC functional clock cycles. From start of read cycle and after FA5 functional clock cycles, input Data will be internally sampled by active functional clock edge. FA5 value must be stored inside AccessTime register bits field.
- (3) GPMC_FCLK is an internal clock (GPMC functional clock) not provided externally.
- (4) The "DIR" (direction control) output signal is NOT pinned out on any of the device pads. It is an internal signal only representing a signal direction on the GPMC data bus.

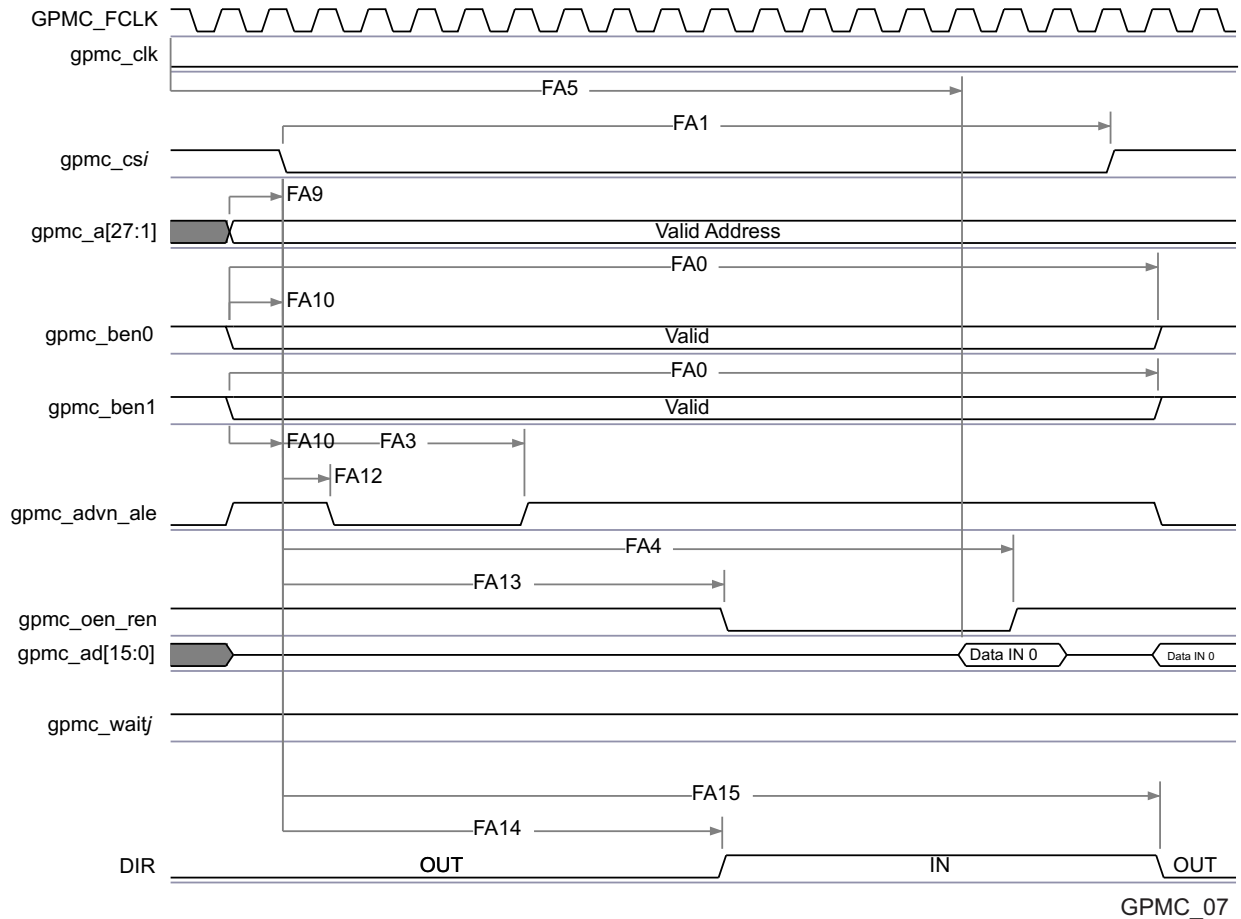
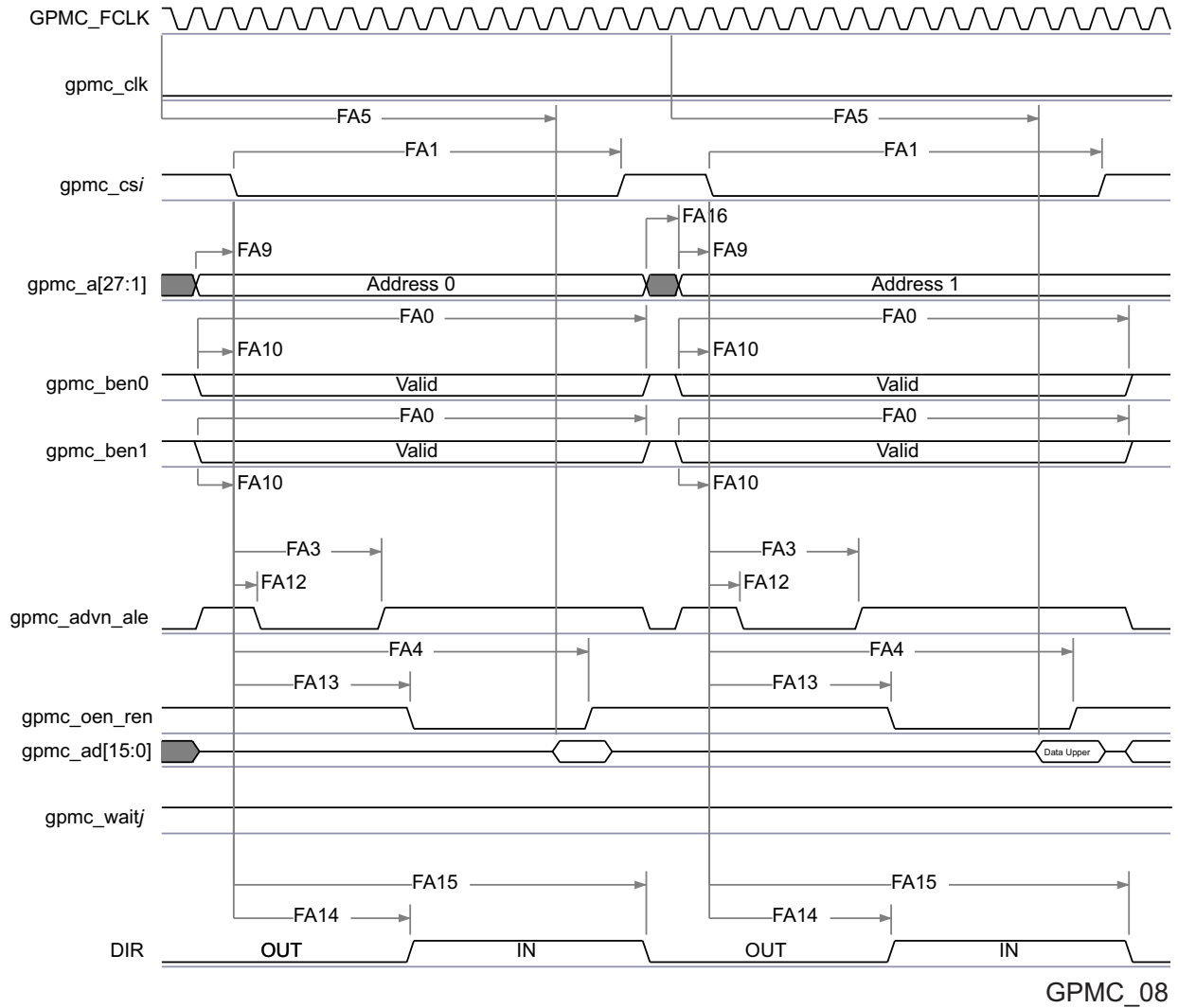
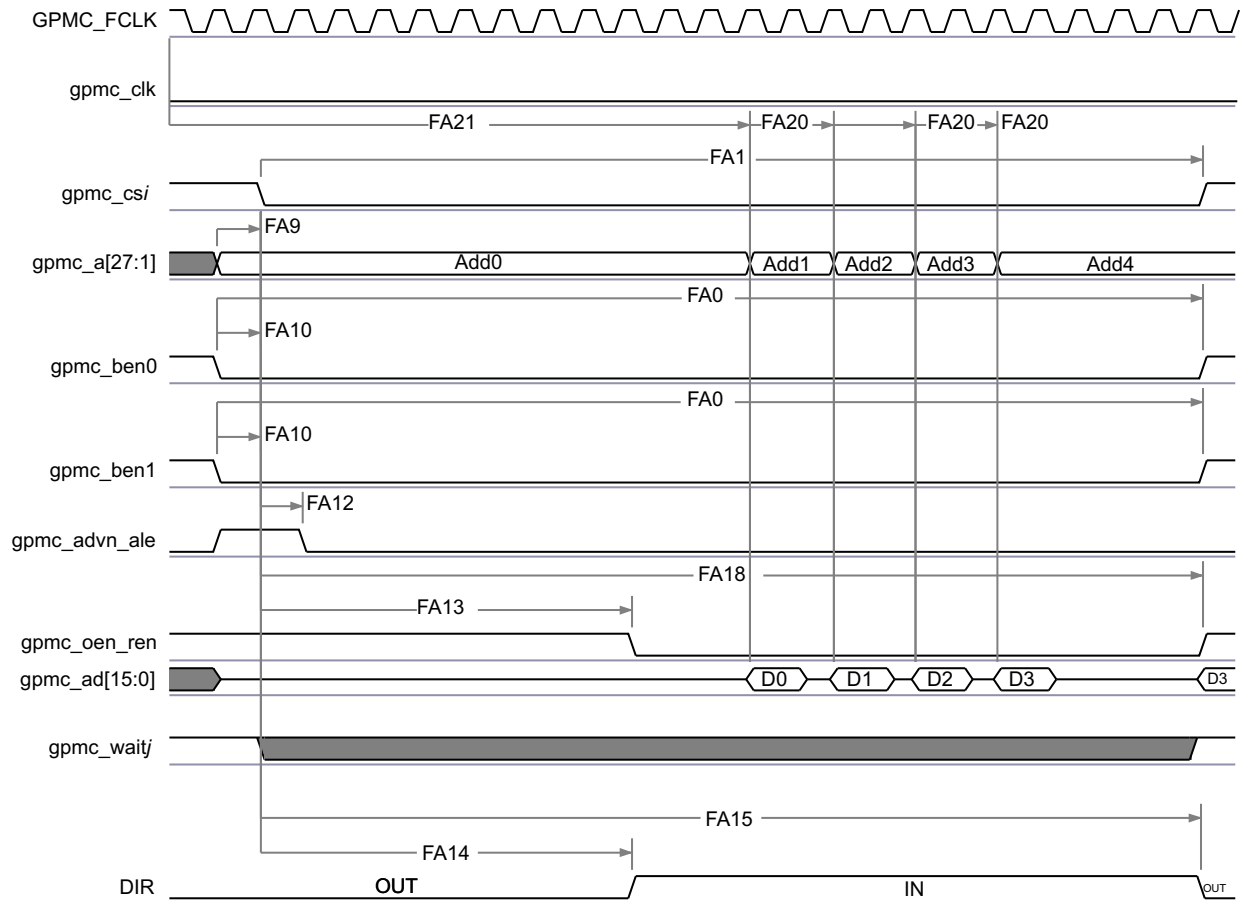

Figure 7-14. GPMC / NOR Flash - Asynchronous Read - 32-bit Timing⁽¹⁾⁽²⁾⁽³⁾⁽⁴⁾

- (1) In $gpmc_csi$, $i = 0$ to 7. In $gpmc_waitj$, $j = 0$ to 1.
- (2) FA5 parameter illustrates amount of time required to internally sample input Data. It is expressed in number of GPMC functional clock cycles. From start of read cycle and after FA5 functional clock cycles, input Data will be internally sampled by active functional clock edge. FA5 value should be stored inside AccessTime register bits field.
- (3) GPMC_FCLK is an internal clock (GPMC functional clock) not provided externally.
- (4) The "DIR" (direction control) output signal is NOT pinned out on any of the device pads. It is an internal signal only representing a signal direction on the GPMC data bus.



SPRS81v_GPMC_09

7-15. GPMC / NOR Flash - Asynchronous Read - Page Mode 4x16-bit Timing⁽¹⁾⁽²⁾⁽³⁾⁽⁴⁾⁽⁵⁾

- (1) In gpmc_csi, i = 0 to 7. In gpmc_waitj, j = 0 to 1.
- (2) FA21 parameter illustrates amount of time required to internally sample first input Page Data. It is expressed in number of GPMC functional clock cycles. From start of read cycle and after FA21 functional clock cycles, First input Page Data will be internally sampled by active functional clock edge. FA21 calculation is detailed in a separated application note and should be stored inside AccessTime register bits field.
- (3) FA20 parameter illustrates amount of time required to internally sample successive input Page Data. It is expressed in number of GPMC functional clock cycles. After each access to input Page Data, next input Page Data will be internally sampled by active functional clock edge after FA20 functional clock cycles. FA20 is also the duration of address phases for successive input Page Data (excluding first input Page Data). FA20 value should be stored in PageBurstAccessTime register bits field.
- (4) GPMC_FCLK is an internal clock (GPMC functional clock) not provided externally.
- (5) The "DIR" (direction control) output signal is NOT pinned out on any of the device pads. It is an internal signal only representing a signal direction on the GPMC data bus.

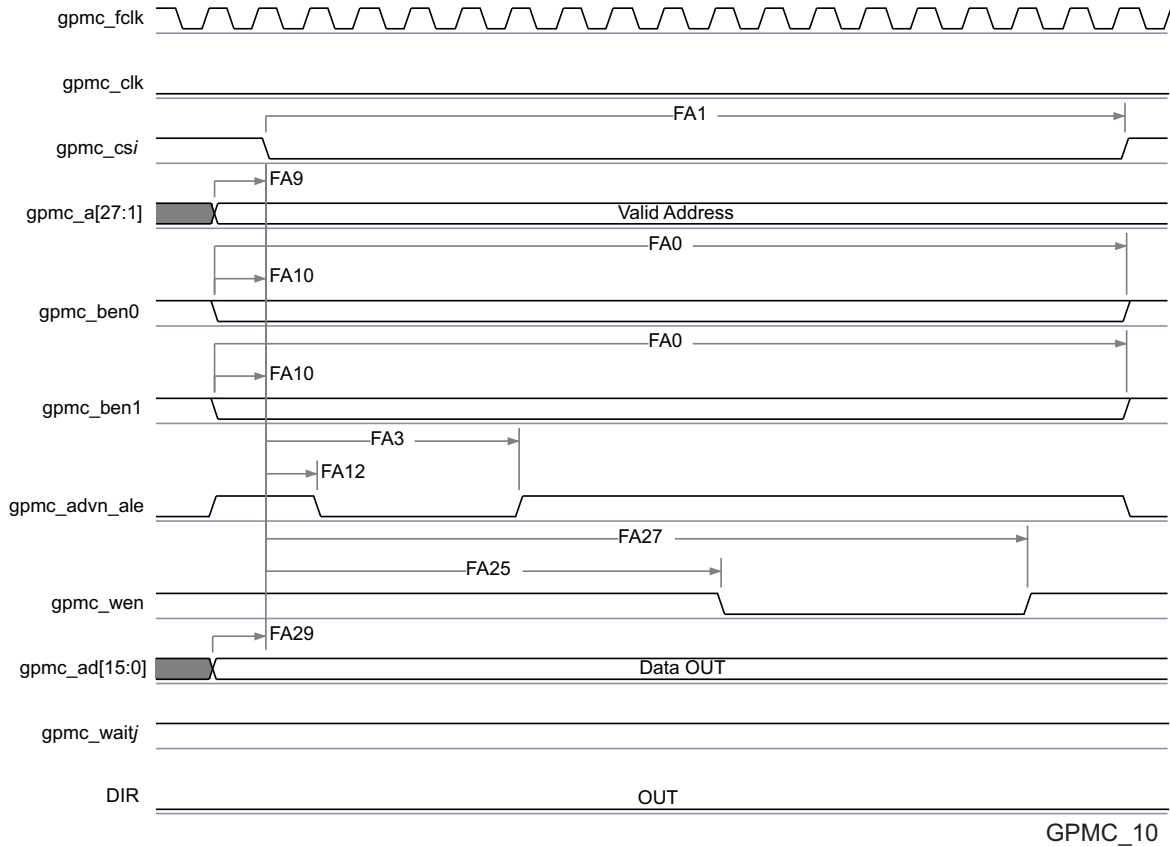

7-16. GPMC / NOR Flash - Asynchronous Write - Single Word Timing⁽¹⁾⁽²⁾

- (1) In gpmc_csi, i = 0 to 7. In gpmc_waitj, j = 0 to 1.
- (2) The "DIR" (direction control) output signal is NOT pinned out on any of the device pads. It is an internal signal only representing a signal direction on the GPMC data bus.

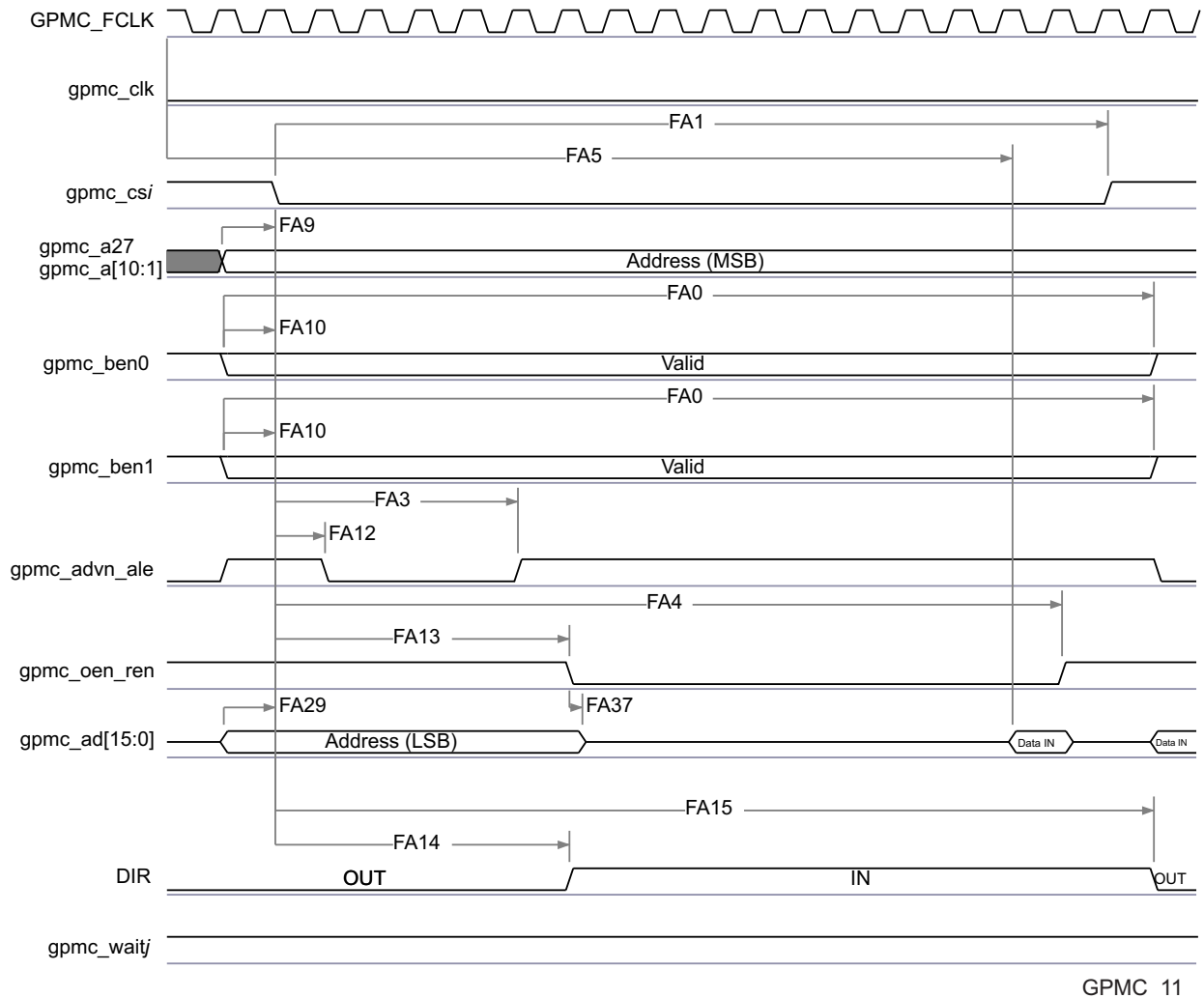

Figure 7-17. GPMC / Multiplexed NOR Flash - Asynchronous Read - Single Word Timing⁽¹⁾⁽²⁾⁽³⁾⁽⁴⁾

- (1) In gpmc_csi, i = 0 to 7. In gpmc_waitj, j = 0 to 1
- (2) FA5 parameter illustrates amount of time required to internally sample input Data. It is expressed in number of GPMC functional clock cycles. From start of read cycle and after FA5 functional clock cycles, input Data will be internally sampled by active functional clock edge. FA5 value should be stored inside AccessTime register bits field.
- (3) GPMC_FCLK is an internal clock (GPMC functional clock) not provided externally
- (4) The "DIR" (direction control) output signal is NOT pinned out on any of the device pads. It is an internal signal only representing a signal direction on the GPMC data bus.



图 7-18. GPMC / Multiplexed NOR Flash - Asynchronous Write - Single Word Timing⁽¹⁾⁽²⁾

- (1) In gpmc_csi, i = 0 to 7. In gpmc_waitj, j = 0 to 1.
- (2) The "DIR" (direction control) output signal is NOT pinned out on any of the device pads. It is an internal signal only representing a signal direction on the GPMC data bus.

7.10.3 GPMC/NAND Flash Interface Asynchronous Timing

注意

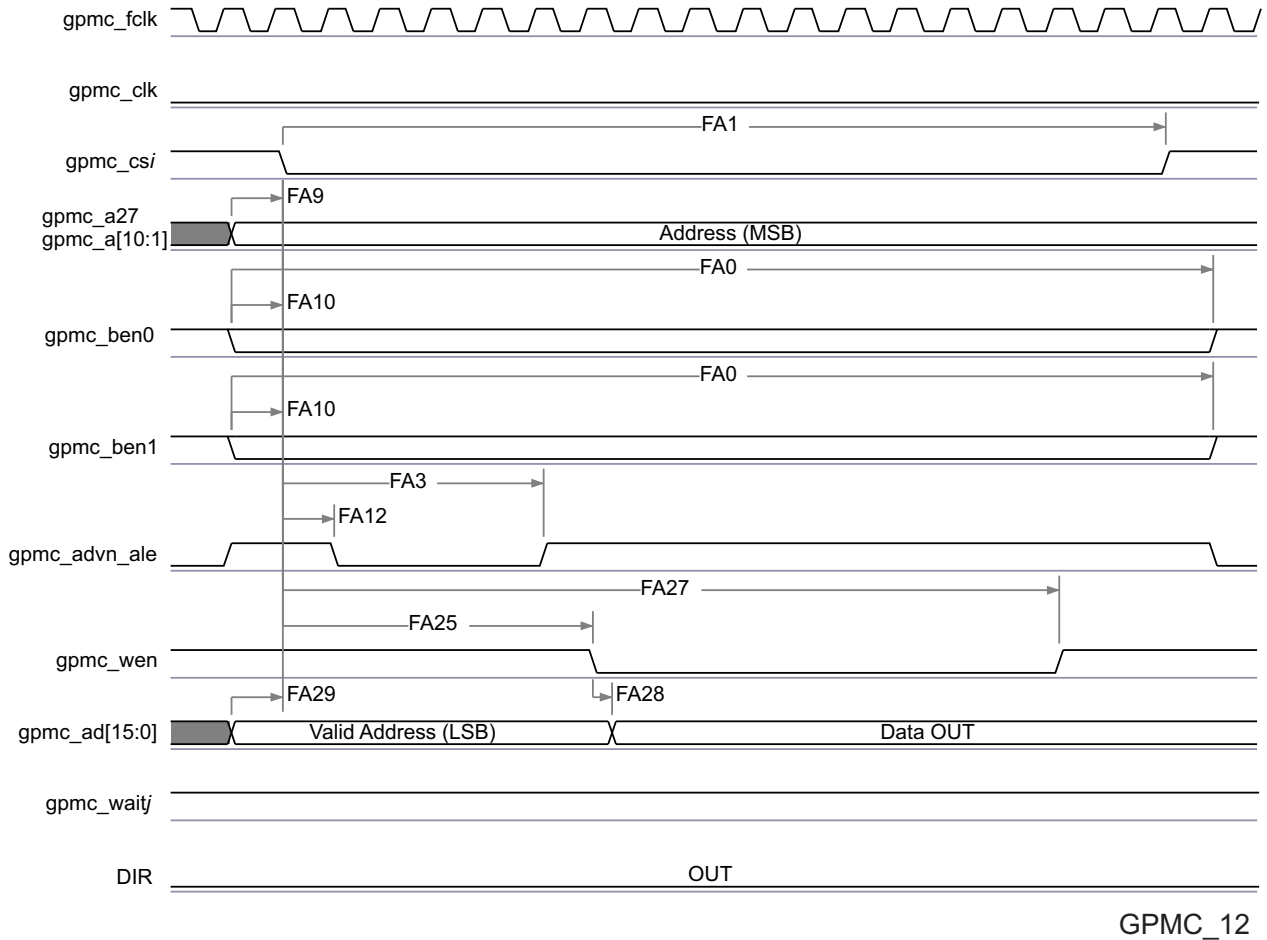
The IO Timings provided in this section are only valid for some GPMC usage modes when the corresponding Virtual IO Timings or Manual IO Timings are configured as described in the tables found in this section.

表 7-31 和 表 7-32 assume testing over the recommended operating conditions and electrical characteristic conditions below (see 图 7-19, 图 7-20, 图 7-21, and 图 7-22).

表 7-31. GPMC/NAND Flash Interface Timing Requirements

NO.	PARAMETER	DESCRIPTION	MIN	MAX	UNIT
GNF12	$t_{acc}(DAT)$	Data maximum access time (GPMC_FCLK Cycles)		J ⁽¹⁾	cycles
-	$t_{su}(DV-OEH)$	Setup time, read gpmc_ad[15:0] valid before gpmc_oen_ren high	1.9		ns
-	$t_h(OEH-DV)$	Hold time, read gpmc_ad[15:0] valid after gpmc_oen_ren high	1		ns

(1) $J = \text{AccessTime} * (\text{TimeParaGranularity} + 1)$

表 7-32. GPMC/NAND Flash Interface Switching Characteristics

NO.	PARAMETER	DESCRIPTION	MIN	MAX	UNIT
-	$t_{r(\text{DO})}$	Rising time, gpmc_ad[15:0] output data	0.447	4.067	ns
-	$t_{f(\text{DO})}$	Falling time, gpmc_ad[15:0] output data	0.43	4.463	ns
GNF0	$t_{w(\text{nWEV})}$	Pulse duration, gpmc_wen valid time		A ⁽¹⁾	ns
GNF1	$t_{d(\text{nCSV-nWEV})}$	Delay time, gpmc_cs[7:0] valid to gpmc_wen valid	B - 2 ⁽²⁾	B + 4 ⁽²⁾	ns
GNF2	$t_{d(\text{CLEH-nWEV})}$	Delay time, gpmc_ben[1:0] high to gpmc_wen valid	C - 2 ⁽³⁾	C + 4 ⁽³⁾	ns
GNF3	$t_{d(\text{nWEV-DV})}$	Delay time, gpmc_ad[15:0] valid to gpmc_wen valid	D - 2 ⁽⁴⁾	D + 4 ⁽⁴⁾	ns
GNF4	$t_{d(\text{nWEIV-DIV})}$	Delay time, gpmc_wen invalid to gpmc_ad[15:0] invalid	E - 2 ⁽⁵⁾	E + 4 ⁽⁵⁾	ns
GNF5	$t_{d(\text{nWEIV-CLEIV})}$	Delay time, gpmc_wen invalid to gpmc_ben[1:0] invalid	F - 2 ⁽⁶⁾	F + 4 ⁽⁶⁾	ns
GNF6	$t_{d(\text{nWEIV-nCSIV})}$	Delay time, gpmc_wen invalid to gpmc_cs[7:0] invalid	G - 2 ⁽⁷⁾	G + 4 ⁽⁷⁾	ns
GNF7	$t_{d(\text{ALEH-nWEV})}$	Delay time, gpmc_advn_ale high to gpmc_wen valid	C - 2 ⁽³⁾	C + 4 ⁽³⁾	ns
GNF8	$t_{d(\text{nWEIV-ALEIV})}$	Delay time, gpmc_wen invalid to gpmc_advn_ale invalid	F - 2 ⁽⁶⁾	F + 4 ⁽⁶⁾	ns
GNF9	$t_{c(\text{nWE})}$	Cycle time, write cycle time		H ⁽⁸⁾	ns
GNF10	$t_{d(\text{nCSV-nOEV})}$	Delay time, gpmc_cs[7:0] valid to gpmc_oen_ren valid	I - 2 ⁽⁹⁾	I + 4 ⁽⁹⁾	ns
GNF13	$t_{w(\text{nOEV})}$	Pulse duration, gpmc_oen_ren valid time		K ⁽¹⁰⁾	ns
GNF14	$t_{c(\text{nOE})}$	Cycle time, read cycle time		L ⁽¹¹⁾	ns
GNF15	$t_{d(\text{nOEIV-nCSIV})}$	Delay time, gpmc_oen_ren invalid to gpmc_cs[7:0] invalid	M - 2 ⁽¹²⁾	M + 4 ⁽¹²⁾	ns

(1) $A = (\text{WEOffTime} - \text{WEOnTime}) * (\text{TimeParaGranularity} + 1) * \text{GPMC_FCLK}$

(2) $B = ((\text{WEOnTime} - \text{CSONTime}) * (\text{TimeParaGranularity} + 1) + 0.5 * (\text{WEEExtraDelay} - \text{CSEExtraDelay})) * \text{GPMC_FCLK}$

(3) $C = ((\text{WEOnTime} - \text{ADVOnTime}) * (\text{TimeParaGranularity} + 1) + 0.5 * (\text{WEEExtraDelay} - \text{ADVExtraDelay})) * \text{GPMC_FCLK}$

(4) $D = (\text{WEOnTime} * (\text{TimeParaGranularity} + 1) + 0.5 * \text{WEEExtraDelay}) * \text{GPMC_FCLK}$

(5) $E = (\text{WrCycleTime} - \text{WEOffTime} * (\text{TimeParaGranularity} + 1) - 0.5 * \text{WEEExtraDelay}) * \text{GPMC_FCLK}$

(6) $F = (\text{ADVWrOffTime} - \text{WEOffTime} * (\text{TimeParaGranularity} + 1) + 0.5 * (\text{ADVExtraDelay} - \text{WEEExtraDelay})) * \text{GPMC_FCLK}$

(7) $G = (\text{CSWrOffTime} - \text{WEOffTime} * (\text{TimeParaGranularity} + 1) + 0.5 * (\text{CSEExtraDelay} - \text{WEEExtraDelay})) * \text{GPMC_FCLK}$

(8) $H = \text{WrCycleTime} * (1 + \text{TimeParaGranularity}) * \text{GPMC_FCLK}$

(9) $I = ((\text{OEOffTime} + (n - 1) * \text{PageBurstAccessTime} - \text{CSONTime}) * (\text{TimeParaGranularity} + 1) + 0.5 * (\text{OEEExtraDelay} - \text{CSEExtraDelay})) * \text{GPMC_FCLK}$

(10) $K = (\text{OEOffTime} - \text{OEOnTime}) * (1 + \text{TimeParaGranularity}) * \text{GPMC_FCLK}$

(11) $L = \text{RdCycleTime} * (1 + \text{TimeParaGranularity}) * \text{GPMC_FCLK}$

(12) $M = (\text{CSRdOffTime} - \text{OEOffTime} * (\text{TimeParaGranularity} + 1) + 0.5 * (\text{CSEExtraDelay} - \text{OEEExtraDelay})) * \text{GPMC_FCLK}$

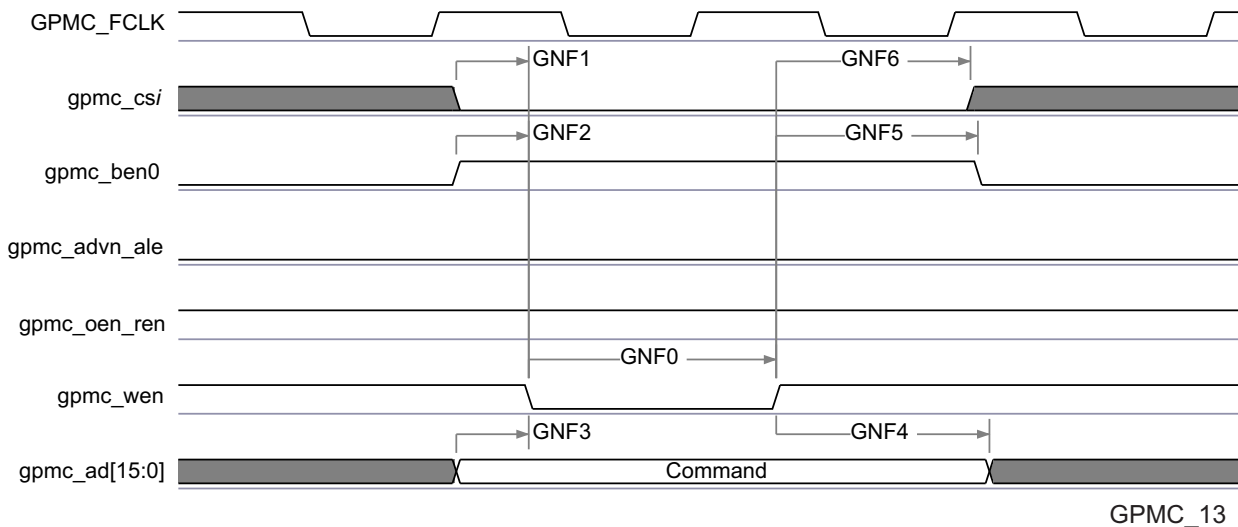

7-19. GPMC / NAND Flash - Command Latch Cycle Timing⁽¹⁾

(1) In gpmc_csi, i = 0 to 7.

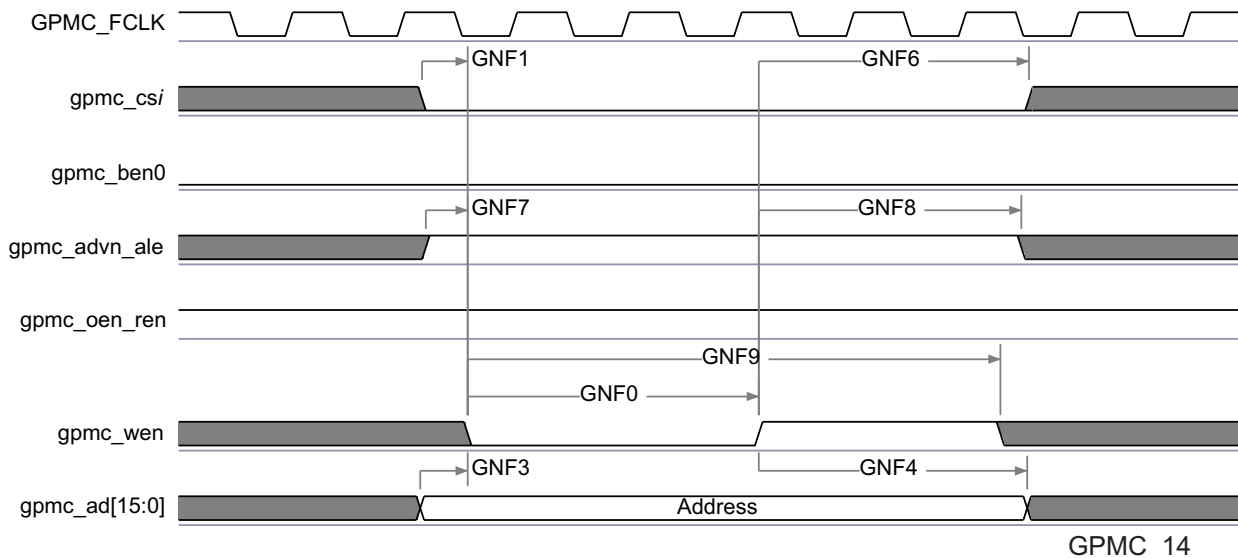

7-20. GPMC / NAND Flash - Address Latch Cycle Timing⁽¹⁾

(1) In gpmc_csi, i = 0 to 7.



图 7-21. GPMC / NAND Flash - Data Read Cycle Timing⁽¹⁾⁽²⁾⁽³⁾

- (1) GNF12 parameter illustrates amount of time required to internally sample input Data. It is expressed in number of GPMC functional clock cycles. From start of read cycle and after GNF12 functional clock cycles, input data will be internally sampled by active functional clock edge. GNF12 value must be stored inside AccessTime register bits field.
- (2) GPMC_FCLK is an internal clock (GPMC functional clock) not provided externally.
- (3) In gpmc_csi, i = 0 to 7. In gpmc_waitj, j = 0 to 1.

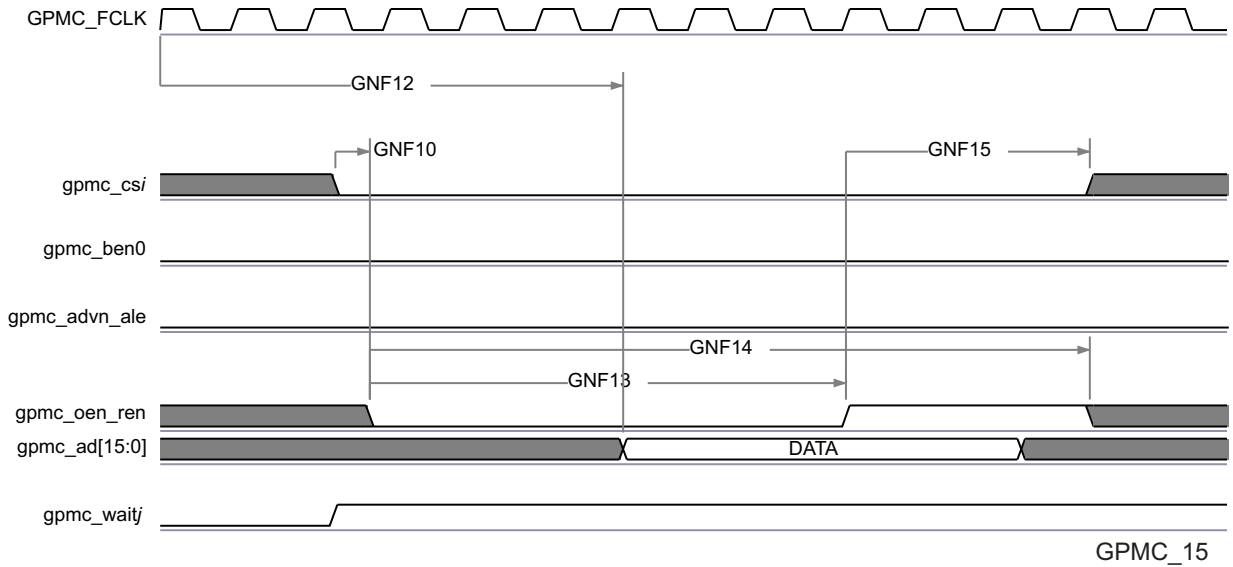

图 7-22. GPMC / NAND Flash - Data Write Cycle Timing⁽¹⁾

- (1) In gpmc_csi, i = 0 to 7.

注: To configure the desired virtual mode the user must set MODESELECT bit and DELAYMODE bitfield for each corresponding pad control register.

The pad control registers are presented in 表 4-3 and described in Device TRM, Chapter 18 - Control Module.

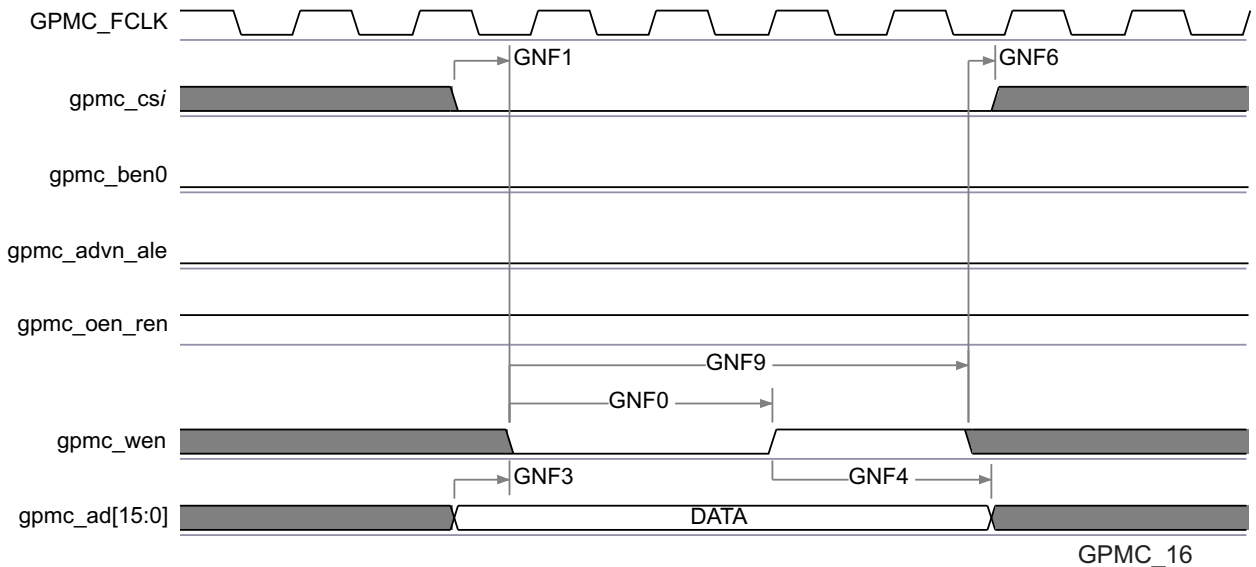
Virtual IO Timings Modes must be used to ensure some IO timings for GPMC. See 表 7-2 Modes Summary for a list of IO timings requiring the use of Virtual IO Timings Modes. See 表 7-33 Virtual Functions Mapping for GPMC for a definition of the Virtual modes.

表 7-33 presents the values for DELAYMODE bitfield.

表 7-33. Virtual Functions Mapping for GPMC

BALL	BALL NAME	Delay Mode Value	MUXMODE[15:0]						
			GPMC_VIRTUAL1	0	1	2	3	5	6
M6	gpmc_ad0	11	gpmc_ad0						
M2	gpmc_ad1	11	gpmc_ad1						
L5	gpmc_ad2	11	gpmc_ad2						
M1	gpmc_ad3	11	gpmc_ad3						
L6	gpmc_ad4	11	gpmc_ad4						
L4	gpmc_ad5	11	gpmc_ad5						
L3	gpmc_ad6	11	gpmc_ad6						
L2	gpmc_ad7	11	gpmc_ad7						
L1	gpmc_ad8	11	gpmc_ad8						
K2	gpmc_ad9	11	gpmc_ad9						
J1	gpmc_ad10	11	gpmc_ad10						
J2	gpmc_ad11	11	gpmc_ad11						
H1	gpmc_ad12	11	gpmc_ad12						
J3	gpmc_ad13	11	gpmc_ad13						
H2	gpmc_ad14	11	gpmc_ad14						
H3	gpmc_ad15	11	gpmc_ad15						
R6	gpmc_a0	11	gpmc_a0						
T9	gpmc_a1	11	gpmc_a1						
T6	gpmc_a2	11	gpmc_a2						
T7	gpmc_a3	10	gpmc_a3						
P6	gpmc_a4	10	gpmc_a4						
R9	gpmc_a5	11	gpmc_a5						
R5	gpmc_a6	11	gpmc_a6						
P5	gpmc_a7	11	gpmc_a7						
N7	gpmc_a8	12	gpmc_a8						
R4	gpmc_a9	12	gpmc_a9						
N9	gpmc_a10	12	gpmc_a10						
P9	gpmc_a11	11	gpmc_a11						
P4	gpmc_a12	13	gpmc_a12					gpmc_a0	
R3	gpmc_a13	12	gpmc_a13						
T2	gpmc_a14	12	gpmc_a14						
U2	gpmc_a15	12	gpmc_a15						
U1	gpmc_a16	12	gpmc_a16						
P3	gpmc_a17	12	gpmc_a17						
R2	gpmc_a18	12	gpmc_a18						
K7	gpmc_a19	11	gpmc_a19			gpmc_a13			
M7	gpmc_a20	11	gpmc_a20			gpmc_a14			
J5	gpmc_a21	11	gpmc_a21			gpmc_a15			
K6	gpmc_a22	11	gpmc_a22			gpmc_a16			
J7	gpmc_a23	11	gpmc_a23			gpmc_a17			
J4	gpmc_a24	11	gpmc_a24			gpmc_a18			
J6	gpmc_a25	11	gpmc_a25			gpmc_a19			
H4	gpmc_a26	11	gpmc_a26			gpmc_a20			
H5	gpmc_a27	11	gpmc_a27			gpmc_a21			

表 7-33. Virtual Functions Mapping for GPMC (continued)

BALL	BALL NAME	Delay Mode Value	MUXMODE[15:0]							
			GPMC_VIRTUAL1	0	1	2	3	5	6	
H6	gpmc_cs1	11	gpmc_cs1			gpmc_a22				
T1	gpmc_cs0	14	gpmc_cs0							
P2	gpmc_cs2	12	gpmc_cs2							
P1	gpmc_cs3	10	gpmc_cs3					gpmc_a1		
P7	gpmc_clk	12	gpmc_clk	gpmc_cs7			gpmc_wait1			
N1	gpmc_advn_ale	13	gpmc_advn_ale	gpmc_cs6			gpmc_wait1	gpmc_a2	gpmc_a23	
M5	gpmc_oen_ren	14	gpmc_oen_ren							
M3	gpmc_wen	14	gpmc_wen							
N6	gpmc_ben0	11	gpmc_ben0	gpmc_cs4						
M4	gpmc_ben1	11	gpmc_ben1	gpmc_cs5				gpmc_a3		
N2	gpmc_wait0	14	gpmc_wait0							
AG5	vin1a_d11	9						gpmc_a23		
AF2	vin1a_d12	9						gpmc_a24		
AF6	vin1a_d13	9						gpmc_a25		
AF3	vin1a_d14	9						gpmc_a26		
AF4	vin1a_d15	9						gpmc_a27		

7.11 Timers

The device has 16 general-purpose (GP) timers (TIMER1 - TIMER16), two watchdog timers, and a 32-kHz synchronized timer (COUNTER_32K) that have the following features:

- Dedicated input trigger for capture mode and dedicated output trigger/pulse width modulation (PWM) signal
- Interrupts generated on overflow, compare, and capture
- Free-running 32-bit upward counter
- Supported modes:
 - Compare and capture modes
 - Auto-reload mode
 - Start-stop mode
- On-the-fly read/write register (while counting)

The device has two system watchdog timer (WD_TIMER1 and WD_TIMER2) that have the following features:

- Free-running 32-bit upward counter
- On-the-fly read/write register (while counting)
- Reset upon occurrence of a timer overflow condition

The device includes one instance of the 32-bit watchdog timer: WD_TIMER2, also called the MPU watchdog timer.

The watchdog timer is used to provide a recovery mechanism for the device in the event of a fault condition, such as a non-exiting code loop.

注: For additional information on the Timer Module, see the Device TRM.

7.12 Inter-Integrated Circuit Interface (I2C)

The device includes 5 inter-integrated circuit (I2C) modules which provide an interface to other devices compliant with Philips Semiconductors Inter-IC bus (I2C-bus™) specification version 2.1. External components attached to this 2-wire serial bus can transmit/receive 8-bit data to/from the device through the I2C module.

注: Note that, on I2C1 and I2C2, due to characteristics of the open drain IO cells, HS mode is not supported

注: Inter-integrated circuit i (i=1 to 5) module is also referred to as I2Ci

注: For more information, see the Multimaster High-Speed I2C Controller section of the Device TRM.

表 7-34, 表 7-35 和 图 7-23 assume testing over the recommended operating conditions and electrical characteristic conditions below.

表 7-34. Timing Requirements for I²C Input Timings⁽¹⁾

NO.	PARAMETER	DESCRIPTION	STANDARD MODE		FAST MODE		UNIT
			MIN	MAX	MIN	MAX	
1	t _{c(SCL)}	Cycle time, SCL	10		2.5		μs
2	t _{su(SCLH-SDAL)}	Setup time, SCL high before SDA low (for a repeated START condition)	4.7		0.6		μs
3	t _{h(SDAL-SCLL)}	Hold time, SCL low after SDA low (for a START and a repeated START condition)	4		0.6		μs
4	t _{w(SCLL)}	Pulse duration, SCL low	4.7		1.3		μs
5	t _{w(SCLH)}	Pulse duration, SCL high	4		0.6		μs
6	t _{su(SDAV-SCLH)}	Setup time, SDA valid before SCL high	250		100 ⁽²⁾		ns
7	t _{h(SCLL-SDAV)}	Hold time, SDA valid after SCL low	0 ⁽³⁾	3.45 ⁽⁴⁾	0 ⁽³⁾	0.9 ⁽⁴⁾	μs
8	t _{w(SDAH)}	Pulse duration, SDA high between STOP and START conditions	4.7		1.3		μs
9	t _{r(SDA)}	Rise time, SDA		1000	20 + 0.1C _b ⁽⁵⁾	300 ⁽³⁾	ns
10	t _{r(SCL)}	Rise time, SCL		1000	20 + 0.1C _b ⁽⁵⁾	300 ⁽³⁾	ns
11	t _{f(SDA)}	Fall time, SDA		300	20 + 0.1C _b ⁽⁵⁾	300 ⁽³⁾	ns
12	t _{f(SCL)}	Fall time, SCL		300	20 + 0.1C _b ⁽⁵⁾	300 ⁽³⁾	ns
13	t _{su(SCLH-SDAH)}	Setup time, SCL high before SDA high (for STOP condition)	4		0.6		μs
14	t _{w(SP)}	Pulse duration, spike (must be suppressed)			0	50	ns
15	C _b ⁽⁵⁾	Capacitive load for each bus line		400		400	pF

(1) The I2C pins SDA and SCL do not feature fail-safe I/O buffers. These pins could potentially draw current when the device is powered down.

(2) A Fast-mode I²C-bus™ device can be used in a Standard-mode I²C-bus system, but the requirement t_{su(SDA-SCLH)} ≥ 250 ns must then be met. This will automatically be the case if the device does not stretch the LOW period of the SCL signal. If such a device does stretch the LOW period of the SCL signal, it must output the next data bit to the SDA line t_r max + t_{su(SDA-SCLH)} = 1000 + 250 = 1250 ns (according to the Standard-mode I²C-Bus Specification) before the SCL line is released.

(3) A device must internally provide a hold time of at least 300 ns for the SDA signal (referred to the V_{IHmin} of the SCL signal) to bridge the undefined region of the falling edge of SCL.

(4) The maximum t_{h(SDA-SCLL)} has only to be met if the device does not stretch the low period [t_{w(SCLL)}] of the SCL signal.

(5) C_b = total capacitance of one bus line in pF. If mixed with HS-mode devices, faster fall-times are allowed.

表 7-35. Timing Requirements for I²C HS-Mode (I²C3/4/5 Only)⁽¹⁾

NO.	PARAMETER	DESCRIPTION	C _b = 100 pF MAX		C _b = 400 pF ⁽²⁾		UNIT
			MIN	MAX	MIN	MAX	
1	t _c (SCL)	Cycle time, SCL	0.294		0.588		us
2	t _{su} (SCLH-SDAL)	Set-up time, SCL high before SDA low (for a repeated START condition)	160		160		ns
3	t _h (SDAL-SCLL)	Hold time, SCL low after SDA low (for a repeated START condition)	160		160		ns
4	t _w (SCLL)	LOW period of the SCLH clock	160		320		ns
5	t _w (SCLH)	HIGH period of the SCLH clock	60		120		ns
6	t _{su} (SDAV-SCLH)	Setup time, SDA valid before SCL high	10		10		ns
7	t _h (SCLL-SDAV)	Hold time, SDA valid after SCL low	0 ⁽³⁾	70	0 ⁽³⁾	150	ns
13	t _{su} (SCLH-SDAH)	Setup time, SCL high before SDA high (for a STOP condition)	160		160		ns
14	t _w (SP)	Pulse duration, spike (must be suppressed)	0	10	0	10	ns
15	C _b ⁽²⁾	Capacitive load for SDAH and SCLH lines		100		400	pF
16	C _b	Capacitive load for SDAH + SDA line and SCLH + SCL line		400		400	pF

(1) I²C HS-Mode is only supported on I²C3/4/5. I²C HS-Mode is not supported on I²C1/2.

(2) For bus line loads C_b between 100 and 400 pF the timing parameters must be linearly interpolated.

(3) A device must internally provide a Data hold time to bridge the undefined part between V_{IH} and V_{IL} of the falling edge of the SCLH signal. An input circuit with a threshold as low as possible for the falling edge of the SCLH signal minimizes this hold time.



图 7-23. I2C Receive Timing

表 7-36 和 图 7-24 假设测试在推荐的运行条件和电气特性条件下进行。

表 7-36. Switching Characteristics Over Recommended Operating Conditions for I2C Output Timings⁽²⁾

NO.	PARAMETER	DESCRIPTION	STANDARD MODE		FAST MODE		UNIT
			MIN	MAX	MIN	MAX	
16	t _c (SCL)	Cycle time, SCL	10		2.5		μs
17	t _{su} (SCLH-SDAL)	Setup time, SCL high before SDA low (for a repeated START condition)	4.7		0.6		μs
18	t _h (SDAL-SCLL)	Hold time, SCL low after SDA low (for a START and a repeated START condition)	4		0.6		μs

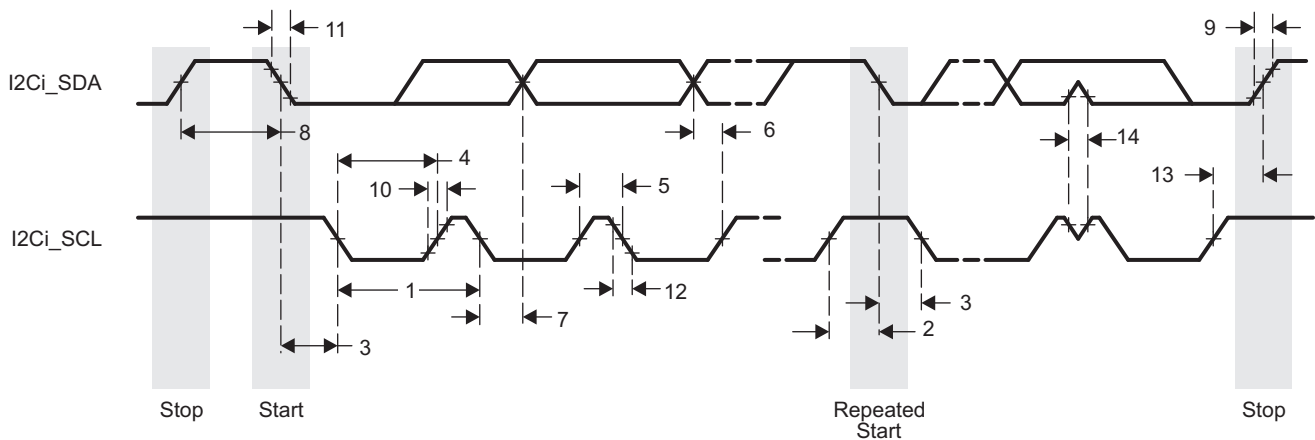
表 7-36. Switching Characteristics Over Recommended Operating Conditions for I2C Output Timings⁽²⁾ (continued)

NO.	PARAMETER	DESCRIPTION	STANDARD MODE		FAST MODE		UNIT
			MIN	MAX	MIN	MAX	
19	$t_{w(SCLL)}$	Pulse duration, SCL low	4.7		1.3		μs
20	$t_{w(SCLH)}$	Pulse duration, SCL high	4		0.6		μs
21	$t_{su(SDAV-SCLH)}$	Setup time, SDA valid before SCL high	250		100		ns
22	$t_h(SCLL-SDAV)$	Hold time, SDA valid after SCL low (for I2C bus devices)	0	3.45	0	0.9	μs
23	$t_{w(SDAH)}$	Pulse duration, SDA high between STOP and START conditions	4.7		1.3		μs
24	$t_r(SDA)$	Rise time, SDA		1000	$20 + 0.1C_b$ ^{(1) (3)}	$300^{(3)}$	ns
25	$t_r(SCL)$	Rise time, SCL		1000	$20 + 0.1C_b$ ^{(1) (3)}	$300^{(3)}$	ns
26	$t_f(SDA)$	Fall time, SDA		300	$20 + 0.1C_b$ ^{(1) (3)}	$300^{(3)}$	ns
27	$t_f(SCL)$	Fall time, SCL		300	$20 + 0.1C_b$ ^{(1) (3)}	$300^{(3)}$	ns
28	$t_{su(SCLH-SDAH)}$	Setup time, SCL high before SDA high (for STOP condition)	4		0.6		μs
29	C_p	Capacitance for each I2C pin		10		10	pF

(1) C_b = total capacitance of one bus line in pF. If mixed with HS-mode devices, faster fall-times are allowed.

(2) Software must properly configure the I2C module registers to achieve the timings shown in this table. See the Device TRM for details.

(3) These timings apply only to I2C1 and I2C2. I2C3, I2C4, and I2C5 use standard LVCMOS buffers to emulate open-drain buffers and their rise/fall times should be referenced in the device IBIS model.

注: I2C emulation is achieved by configuring the LVCMOS buffers to output Hi-Z instead of driving high when transmitting logic-1.



图 7-24. I2C Transmit Timing

7.13 HDQ / 1-Wire Interface (HDQ1W)

The module is intended to work with both HDQ and 1-Wire protocols. The protocols use a single wire to communicate between the master and the slave. The protocols employ an asynchronous return to one mechanism where, after any command, the line is pulled high.

注: For more information, see the HDQ / 1-Wire section of the Device TRM.

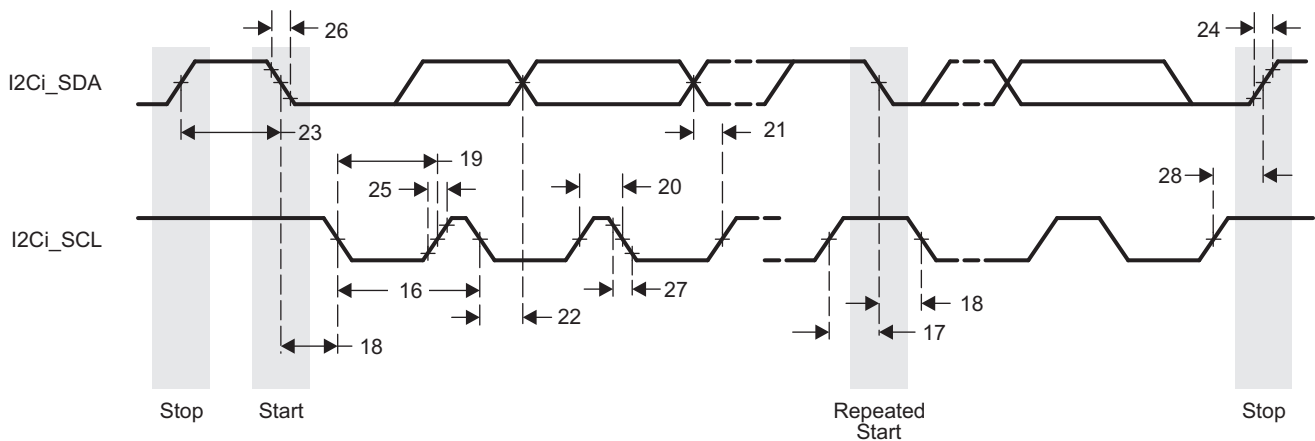
7.13.1 HDQ / 1-Wire — HDQ Mode

表 7-37 和 表 7-38 假设测试 over the recommended operating conditions and electrical characteristic conditions below (see 图 7-25, 图 7-26, 图 7-27 和 图 7-28).

表 7-37. HDQ/1-Wire Timing Requirements—HDQ Mode

NO.	PARAMETER	DESCRIPTION	MIN	MAX	UNIT
1	t_{CYCH}	Read bit window timing	190	250	μs
2	t_{HW1}	Read one data valid after HDQ low	32 ⁽²⁾	66 ⁽²⁾	μs
3	t_{HW0}	Read zero data hold after HDQ low	70 ⁽²⁾	145 ⁽²⁾	μs
4	t_{RSPS}	Response time from HDQ slave device ⁽¹⁾	190	320	μs

(1) Defined by software.

(2) If the HDQ slave device drives a logic-low state after t_{HW0} maximum, it can be interpreted as a break pulse. For more information see "HDQ / 1-Wire Switching Characteristics - HDQ Mode" and the HDQ/1-Wire chapter of the TRM.

表 7-38. HDQ / 1-Wire Switching Characteristics - HDQ Mode

NO.	PARAMETER	DESCRIPTION	MIN	MAX	UNIT
5	t_B	Break timing	190		μs
6	t_{BR}	Break recovery time	40		μs
7	t_{CYCD}	Write bit windows timing	190		μs
8	t_{DW1}	Write one data valid after HDQ low	0.5	50	μs
9	t_{DW0}	Write zero data hold after HDQ low	86	145	μs



图 7-25. HDQ Break and Break Recovery Timing — HDQ Interface Writing to Slave



图 7-26. Device HDQ Interface Bit Read Timing (Data)

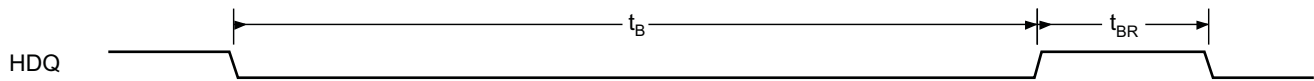

图 7-27. Device HDQ Interface Bit Write Timing (Command / Address or Data)

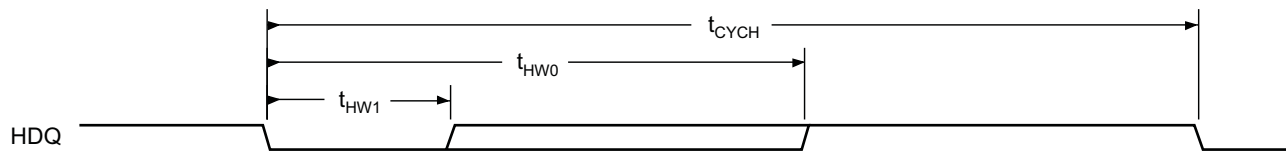

图 7-28. HDQ Communication Timing

7.13.2 HDQ/1-Wire—1-Wire Mode

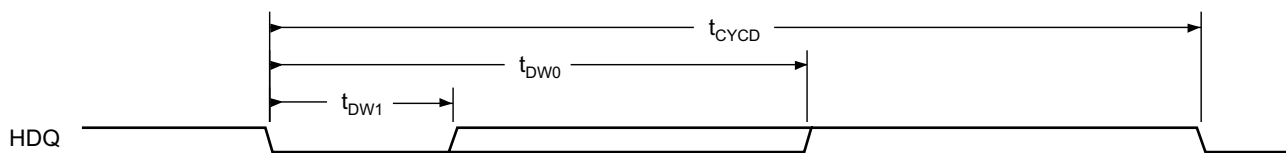
表 7-39 和 表 7-40 假设测试 over the recommended operating conditions and electrical characteristic conditions below (see 图 7-29, 图 7-30 和 图 7-31).

表 7-39. HDQ / 1-Wire Timing Requirements - 1-Wire Mode

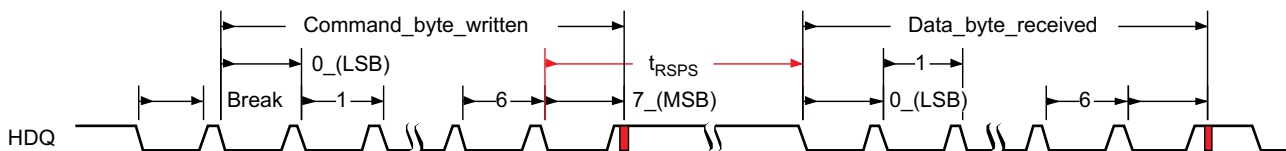
NO.	PARAMETER	DESCRIPTION	MIN	MAX	UNIT
10	t_{PDH}	Presence pulse delay high	15	60	μs
11	t_{PDL}	Presence pulse delay low	60	240	μs
12	t_{RDV}	Read data valid time	t_{LOWR}	15	μs
13	t_{REL}	Read data release time	0	45	μs

表 7-40. HDQ / 1-Wire Switching Characteristics - 1-Wire Mode

NO.	PARAMETER	DESCRIPTION	MIN	MAX	UNIT
14	t_{RSTL}	Reset time low	480	960	μs
15	t_{RSTH}	Reset time high	480		μs
16	t_{SLOT}	Bit cycle time	60	120	μs
17	t_{LOW1}	Write bit-one time	1	15	μs
18	t_{LOW0}	Write bit-zero time ⁽²⁾	60	120	μs
19	t_{REC}	Recovery time	1		μs
20	t_{LOWR}	Read bit strobe time ⁽¹⁾	1	15	μs

(1) t_{LOWR} (low pulse sent by the master) must be short as possible to maximize the master sampling window.

(2) t_{LOW0} must be less than t_{SLOT} .



图 7-29. 1-Wire—Break (Reset)



图 7-30. 1-Wire—Read Bit (Data)

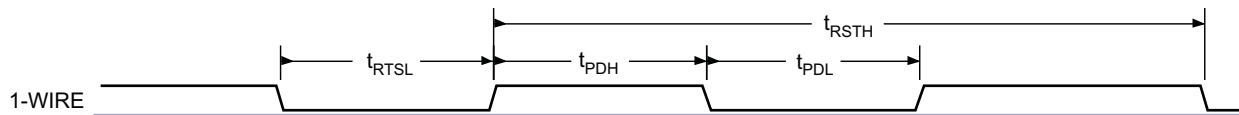

图 7-31. 1-Wire—Write Bit-One Timing (Command / Address or Data)

7.14 Universal Asynchronous Receiver Transmitter (UART)

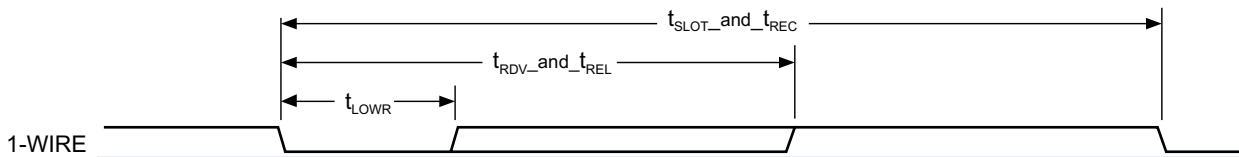
The UART performs serial-to-parallel conversions on data received from a peripheral device and parallel-to-serial conversion on data received from the CPU. There are 10 UART modules in the device. Only one UART supports IrDA features. Each UART can be used for configuration and data exchange with a number of external peripheral devices or interprocessor communication between devices

The UART_i (where $i = 1$ to 10) include the following features:

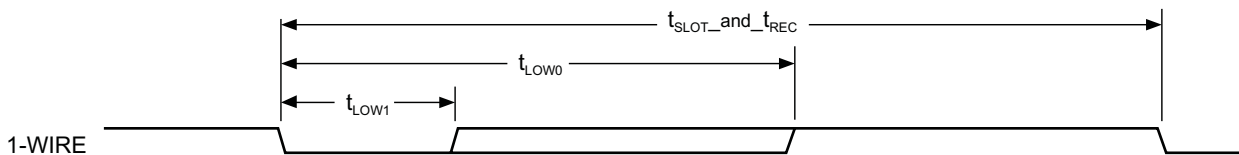
- 16C750 compatibility

- 64-byte FIFO buffer for receiver and 64-byte FIFO for transmitter
- Baud generation based on programmable divisors N (where N = 1...16 384) operating from a fixed functional clock of 48 MHz or 192 MHz
- Break character detection and generation
- Configurable data format:
 - Data bit: 5, 6, 7, or 8 bits
 - Parity bit: Even, odd, none
 - Stop-bit: 1, 1.5, 2 bit(s)
- Flow control: Hardware (RTS/CTS) or software (XON/XOFF)
- Only UART1 module has extended modem control signals (CD, RI, DTR, DSR)
- Only UART3 supports IrDA

注: For more information, see the UART section of the Device TRM.

表 7-41, 表 7-42 和 图 7-32 假设测试 over 的 recommended operating conditions and electrical characteristic conditions below.

表 7-41. Timing Requirements for UART

NO.	PARAMETER	DESCRIPTION	MIN	MAX	UNIT
4	$t_{w(RX)}$	Pulse width, receive data bit, 15/30/100pF high or low	$0.96U^{(1)}$	$1.05U^{(1)}$	ns
5	$t_{w(CTS)}$	Pulse width, receive start bit, 15/30/100pF high or low	$0.96U^{(1)}$	$1.05U^{(1)}$	ns
	$t_{d(RTS-TX)}$	Delay time, transmit start bit to transmit data	$P^{(2)}$		ns
	$t_{d(CTS-TX)}$	Delay time, receive start bit to transmit data	$P^{(2)}$		ns

(1) U = UART baud time = 1/programmed baud rate

(2) P = Clock period of the reference clock (FCLK, usually 48 MHz or 192MHz).

表 7-42. Switching Characteristics Over Recommended Operating Conditions for UART

NO.	PARAMETER	DESCRIPTION	MIN	MAX	UNIT
	$f_{(baud)}$	Maximum programmable baud rate			MHz
		15 pF		12	
		30 pF		0.23	
		100 pF		0.115	
2	$t_{w(TX)}$	Pulse width, transmit data bit, 15/30/100 pF high or low	$U - 2^{(1)}$	$U + 2^{(1)}$	ns
3	$t_{w(RTS)}$	Pulse width, transmit start bit, 15/30/100 pF high or low	$U - 2^{(1)}$	$U + 2^{(1)}$	ns

(1) U = UART baud time = 1/programmed baud rate



图 7-32. UART Timing

7.15 Multichannel Serial Peripheral Interface (McSPI)

The McSPI is a master/slave synchronous serial bus. There are four separate McSPI modules (SPI1, SPI2, SPI3, and SPI4) in the device. All these four modules support up to four external devices (four chip selects) and are able to work as both master and slave.

The McSPI modules include the following main features:

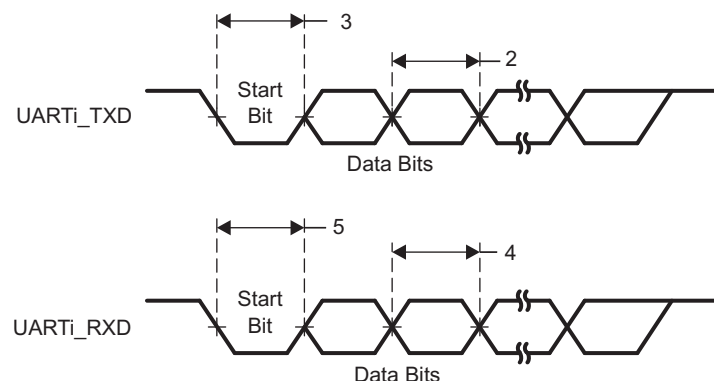
- Serial clock with programmable frequency, polarity, and phase for each channel
- Wide selection of SPI word lengths, ranging from 4 to 32 bits
- Up to four master channels, or single channel in slave mode
- Master multichannel mode:
 - Full duplex/half duplex
 - Transmit-only/receive-only/transmit-and-receive modes
 - Flexible input/output (I/O) port controls per channel
 - Programmable clock granularity
 - SPI configuration per channel. This means, clock definition, polarity enabling and word width
- Power management through wake-up capabilities
- Programmable timing control between chip select and external clock generation
- Built-in FIFO available for a single channel.
- Each SPI module supports multiple chip select pins `spim_cs[i]`, where $i = 1$ to 4.

注: For more information, see the Serial Communication Interface section of the device TRM.

注: The McSPIm module ($m = 1$ to 4) is also referred to as SPIm.

注意

The IO timings provided in this section are applicable for all combinations of signals for SPI1 and SPI2. However, the timings are only valid for SPI3 and SPI4 if signals within a single IOSET are used. The IOSETS are defined in the [表 7-45](#).

表 7-43, [図 7-33](#) and [図 7-34](#) present Timing Requirements for McSPI - Master Mode.

表 7-43. Timing Requirements for SPI - Master Mode ⁽¹⁾⁽⁸⁾

NO.	PARAMETER	DESCRIPTION	MODE	MIN	MAX	UNIT
SM1	$t_c(\text{SPICLK})$	Cycle time, <code>spi_sclk</code> ^{(1) (2)}	SPI1/2/3/4	20.8 ⁽³⁾		ns
SM2	$t_w(\text{SPICLK}_L)$	Typical Pulse duration, <code>spi_sclk</code> low ⁽¹⁾		$0.5 \cdot P - 1$ ⁽⁴⁾		ns
SM3	$t_w(\text{SPICLK}_H)$	Typical Pulse duration, <code>spi_sclk</code> high ⁽¹⁾		$0.5 \cdot P - 1$ ⁽⁴⁾		ns
SM4	$t_{su}(\text{MISO-SPICLK})$	Setup time, <code>spi_d[x]</code> valid before <code>spi_sclk</code> active edge ⁽¹⁾		4.4		ns
SM5	$t_h(\text{SPICLK-MISO})$	Hold time, <code>spi_d[x]</code> valid after <code>spi_sclk</code> active edge ⁽¹⁾		3.9		ns
SM6	$t_d(\text{SPICLK-SIMO})$	Delay time, <code>spi_sclk</code> active edge to <code>spi_d[x]</code> transition ⁽¹⁾	SPI1	-4.27	4.27	ns
			SPI2	-4.32	4.32	ns
			SPI3	-5.37	4.23	ns
			SPI4	-3.81	4.41	ns
SM7	$t_d(\text{CS-SIMO})$	Delay time, <code>spi_cs[x]</code> active edge to <code>spi_d[x]</code> transition			5	ns

表 7-43. Timing Requirements for SPI - Master Mode ⁽¹⁾⁽⁸⁾ (continued)

NO.	PARAMETER	DESCRIPTION	MODE	MIN	MAX	UNIT
SM8	$t_{d(CS-SPICLK)}$	Delay time, spi_cs[x] active to spi_sclk first edge ⁽¹⁾	MASTER_PHA0 ₍₅₎	B-4.6 ⁽⁶⁾		ns
			MASTER_PHA1 ₍₅₎	A-4.6 ⁽⁷⁾		ns
SM9	$t_{d(SPICLK-CS)}$	Delay time, spi_sclk last edge to spi_cs[x] inactive ⁽¹⁾	MASTER_PHA0 ₍₅₎	A-4.6 ⁽⁷⁾		ns
			MASTER_PHA1 ₍₅₎	B-4.6 ⁽⁶⁾		ns

- (1) This timing applies to all configurations regardless of SPI_CLK polarity and which clock edges are used to drive output data and capture input data.
- (2) Related to the SPI_CLK maximum frequency.
- (3) 20.8ns cycle time = 48MHz, 26ns cycle time = 38.4MHz
- (4) P = SPICLK period.
- (5) SPI_CLK phase is programmable with the PHA bit of the SPI_CH(i)CONF register.
- (6) $B = (TCS + 0.5) * TSPICKREF * Fratio$, where TCS is a bit field of the SPI_CH(i)CONF register and Fratio = Even ≥ 2 .
- (7) When P = 20.8 ns, $A = (TCS + 1) * TSPICKREF$, where TCS is a bit field of the SPI_CH(i)CONF register. When P > 20.8 ns, $A = (TCS + 0.5) * Fratio * TSPICKREF$, where TCS is a bit field of the SPI_CH(i)CONF register.
- (8) The IO timings provided in this section are applicable for all combinations of signals for SPI1 and SPI2. However, the timings are only valid for SPI3 and SPI4 if signals within a single IOSET are used. The IOSETs are defined in the following tables.

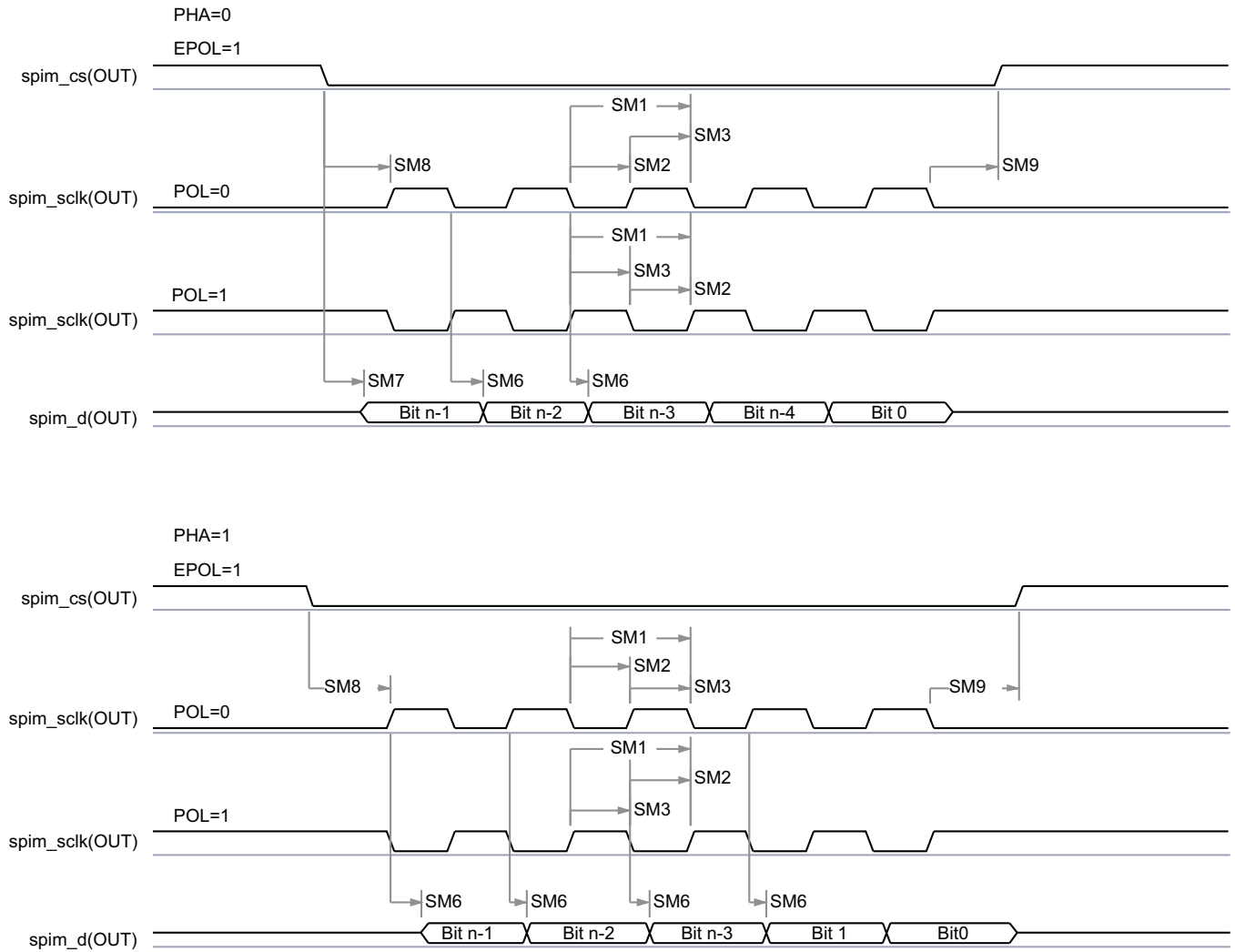

SPRS906_TIMING_McSPI_01

7-33. McSPI - Master Mode Transmit



图 7-34. McSPI - Master Mode Receive

表 7-44, 图 7-35 和 图 7-36 present Timing Requirements for McSPI - Slave Mode.

表 7-44. Timing Requirements for SPI - Slave Mode

NO.	PARAMETER	DESCRIPTION	MODE	MIN	MAX	UNIT
SS1	$t_c(\text{SPICLK})$	Cycle time, spi_sclk ⁽¹⁾ ⁽²⁾	⁽³⁾	62.5		ns
SS2	$t_w(\text{SPICLK}_L)$	Typical Pulse duration, spi_sclk low ⁽¹⁾		0.45*P ⁽⁴⁾		ns
SS3	$t_w(\text{SPICLK}_H)$	Typical Pulse duration, spi_sclk high ⁽¹⁾		0.45*P ⁽⁴⁾		ns
SS4	$t_{su}(\text{SIMO-SPICLK})$	Setup time, spi_d[x] valid before spi_sclk active edge ⁽¹⁾		5		ns
SS5	$t_h(\text{SPICLK-SIMO})$	Hold time, spi_d[x] valid after spi_sclk active edge ⁽¹⁾		5		ns
SS6	$t_d(\text{SPICLK-SOMI})$	Delay time, spi_sclk active edge to mcspi_somi transition ⁽¹⁾	SPI1/2/3	2	26.1	ns
			SPI4	2	18	ns
SS7	$t_d(\text{CS-SOMI})$	Delay time, spi_cs[x] active edge to mcspi_somi transition ⁽¹⁾		20.95		ns
SS8	$t_{su}(\text{CS-SPICLK})$	Setup time, spi_cs[x] valid before spi_sclk first edge ⁽¹⁾		5		ns
SS9	$t_h(\text{SPICLK-CS})$	Hold time, spi_cs[x] valid after spi_sclk last edge ⁽¹⁾		5		ns

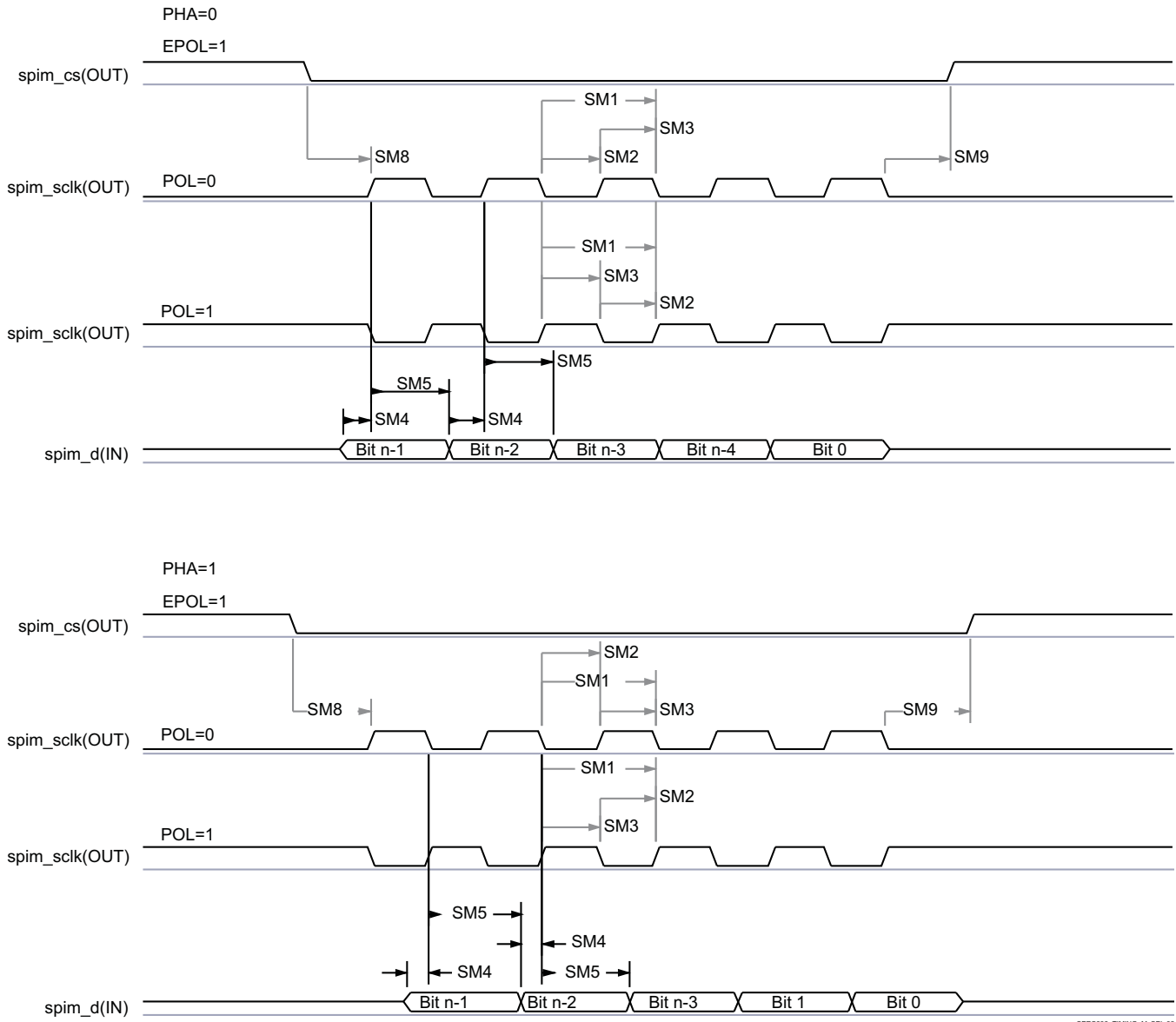
- (1) This timing applies to all configurations regardless of SPI_CLK polarity and which clock edges are used to drive output data and capture input data.
- (2) When operating the SPI interface in RX-only mode, the minimum Cycle time is 26ns (38.4MHz)
- (3) 62.5ns Cycle time = 16 MHz
- (4) P = SPICLK period.
- (5) PHA = 0; SPI_CLK phase is programmable with the PHA bit of the SPI_CH(i)CONF register.

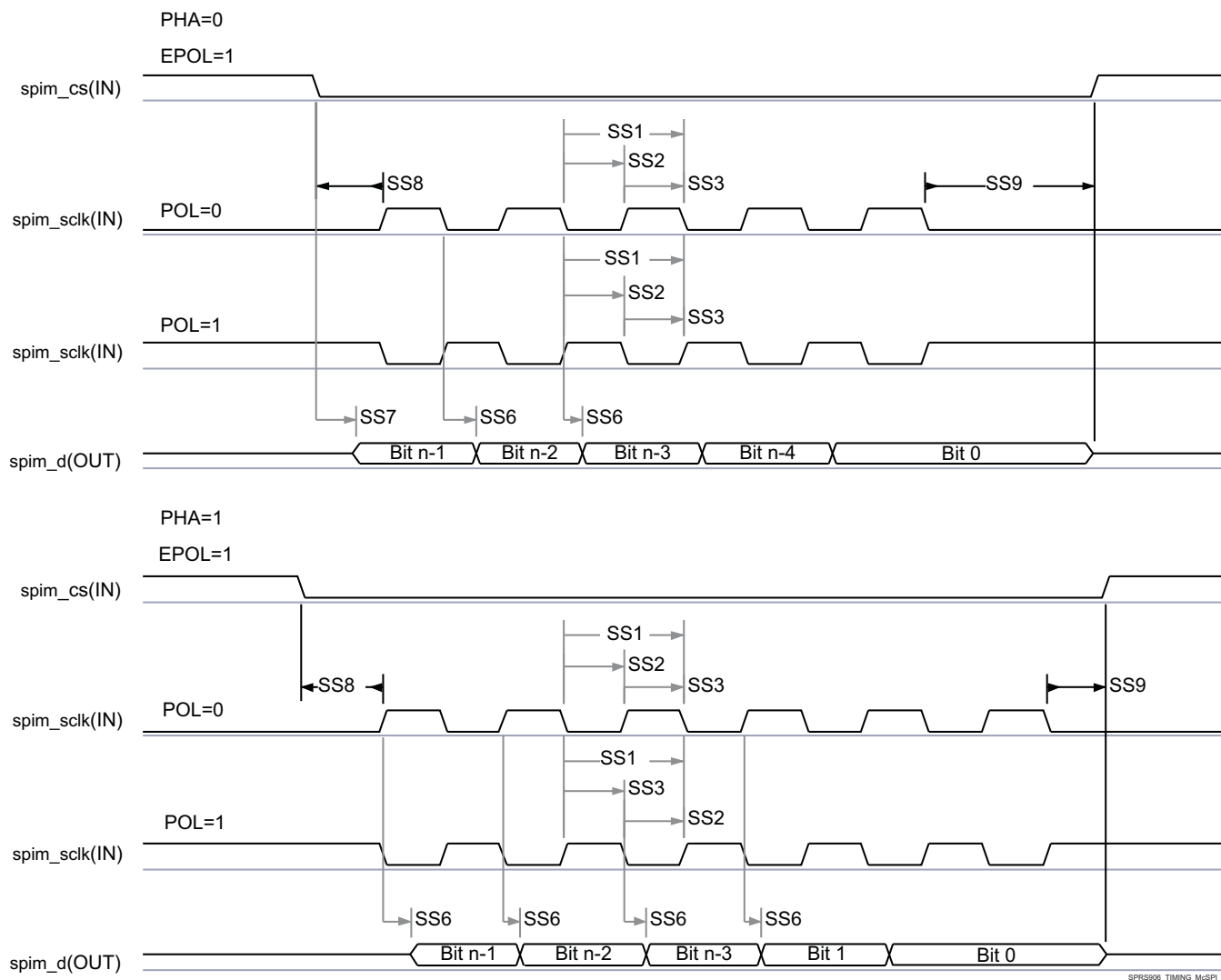

SPRS906_TIMING_McSPI_03

7-35. McSPI - Slave Mode Transmit



图 7-36. McSPI - Slave Mode Receive

In 表 7-45 are presented the specific groupings of signals (IOSET) for use with SPI3 and SPI4.

表 7-45. McSPI3/4 IOSETs

Signal	IOSET1		IOSET2		IOSET3		IOSET4		IOSET5		IOSET6	
	BALL	MUX	BALL	MUX	BALL	MUX	BALL	MUX	BALL	MUX	BALL	MUX
SPI3												
spi3_sclk	AD9	8	E11	8	V2	7	B12	3	C18	2	AC4	1
spi3_d1	AF9	8	B10	8	Y1	7	A11	3	A21	2	AC7	1
spi3_d0	AE9	8	C11	8	W9	7	B13	3	G16	2	AC6	1
spi3_cs0	AF8	8	D11	8	V9	7	A12	3	D17	2	AC9	1
spi3_cs1	AC3	1	B11	8	AC3	1	E14	3	B11	8	AC3	1
spi3_cs2	-	-	F11	8	-	-	F11	8	F11	8	-	-
spi3_cs3	-	-	A10	8	-	-	A10	8	A10	8	-	-
SPI4												
spi4_sclk	N7	8	G1	8	V7	7	AA3	2	AC8	1	-	-

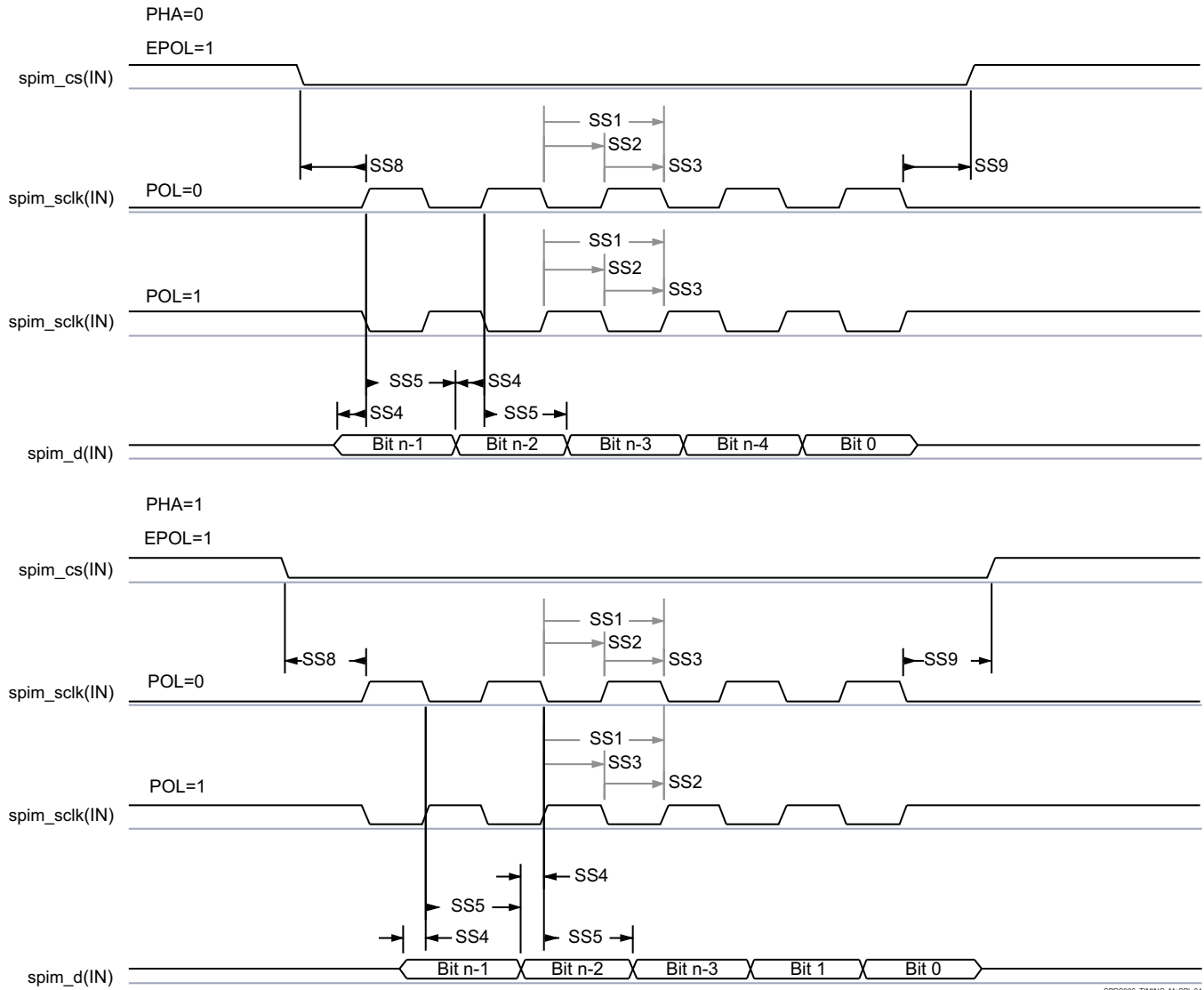
表 7-45. McSPI3/4 IOSETs (continued)

Signal	IOSET1		IOSET2		IOSET3		IOSET4		IOSET5		IOSET6	
	BALL	MUX	BALL	MUX	BALL	MUX	BALL	MUX	BALL	MUX	BALL	MUX
spi4_d1	R4	8	G6	8	U7	7	AB9	2	AD6	1	-	-
spi4_d0	N9	8	F2	8	V6	7	AB3	2	AB8	1	-	-
spi4_cs0	P9	8	F3	8	U6	7	AA4	2	AB5	1	-	-
spi4_cs1	P4	8	P4	8	Y1	8	Y1	8	Y1	8	-	-
spi4_cs2	R3	8	R3	8	W9	8	W9	8	W9	8	-	-
spi4_cs3	T2	8	T2	8	V9	8	V9	8	V9	8	-	-

7.16 Quad Serial Peripheral Interface (QSPI)

The Quad SPI (QSPI) module is a type of SPI module that allows single, dual or quad read access to external SPI devices. This module has a memory mapped register interface, which provides a direct interface for accessing data from external SPI devices and thus simplifying software requirements. It works as a master only. There is one QSPI module in the device and it is primary intended for fast booting from quad-SPI flash memories.

General SPI features:

- Programmable clock divider
- Six pin interface (DCLK, CS_N, DOUT, DIN, QDIN1, QDIN2)
- 4 external chip select signals
- Support for 3-, 4- or 6-pin SPI interface
- Programmable CS_N to DOUT delay from 0 to 3 DCLKs
- Programmable signal polarities
- Programmable active clock edge
- Software controllable interface allowing for any type of SPI transfer

注: For more information, see the Quad Serial Peripheral Interface section of the Device TRM.

注意

The IO Timings provided in this section are only valid for some QSPI usage modes when the corresponding Virtual IO Timings or Manual IO Timings are configured as described in the tables found in this section.

注意

The IO Timings provided in this section are only valid when all QSPI Chip Selects used in a system are configured to use the same Clock Mode (either Clock Mode 0 or Clock Mode3).

表 7-46 和 表 7-47 present Timing and Switching Characteristics for Quad SPI Interface.

表 7-46. Switching Characteristics for QSPI

No	PARAMETER	DESCRIPTION	Mode	MIN	MAX	UNIT
Q1	$t_c(\text{SCLK})$	Cycle time, sclk	Default Timing Mode, Clock Mode 0	13.02		ns
			Default Timing Mode, Clock Mode 3	20.8		ns
Q2	$t_w(\text{SCLKL})$	Pulse duration, sclk low		$Y * P - 1$ (1)		ns
Q3	$t_w(\text{SCLKH})$	Pulse duration, sclk high		$Y * P - 1$ (1)		ns
Q4	$t_d(\text{CS-SCLK})$	Delay time, sclk falling edge to cs active edge, CS3:0	Default Timing Mode	$-M * P - 2.0$ (2) (3)	$-M * P + 2.0$ (2) (3)	ns
Q5	$t_d(\text{SCLK-CS})$	Delay time, sclk falling edge to cs inactive edge, CS3:0	Default Timing Mode	$N * P - 2.0$ (2) (3)	$N * P + 2.0$ (2) (3)	ns
Q6	$t_d(\text{SCLK-D1})$	Delay time, sclk falling edge to d[0] transition	Default Timing Mode	-2	2	ns
Q7	$t_{\text{ena}}(\text{CS-D1LZ})$	Enable time, cs active edge to d[0] driven (lo-z)		-P-3.5	-P+2.5	ns
Q8	$t_{\text{dis}}(\text{CS-D1Z})$	Disable time, cs active edge to d[0] tri-stated (hi-z)		-P-2.5	-P+2.0	ns
Q9	$t_d(\text{SCLK-D0})$	Delay time, sclk first falling edge to first d[0] transition	PHA=0 Only, Default Timing Mode	$-2.45 - P$	$1.45 - P$	ns

(1) The Y parameter is defined as follows:

If DCLK_DIV is 0 or ODD then, Y equals 0.5.

If DCLK_DIV is EVEN then, Y equals $(\text{DCLK_DIV}/2) / (\text{DCLK_DIV}+1)$.

For best performance, it is recommended to use a DCLK_DIV of 0 or ODD to minimize the duty cycle distortion. The HSDIVIDER on CLKOUTX2_H13 output of DPLL_PER can be used to achieve the desired clock divider ratio. All required details about clock division factor DCLK_DIV can be found in the device TRM.

(2) P = SCLK period.

(3) M=QSPI_SPI_DC_REG.DDx + 1 when Clock Mode 0.

M=QSPI_SPI_DC_REG.DDx when Clock Mode 3.

N = 2 when Clock Mode 0.

N = 3 when Clock Mode 3.



图 7-37. QSPI Read (Clock Mode 3)



图 7-38. QSPI Read (Clock Mode 0)

注意

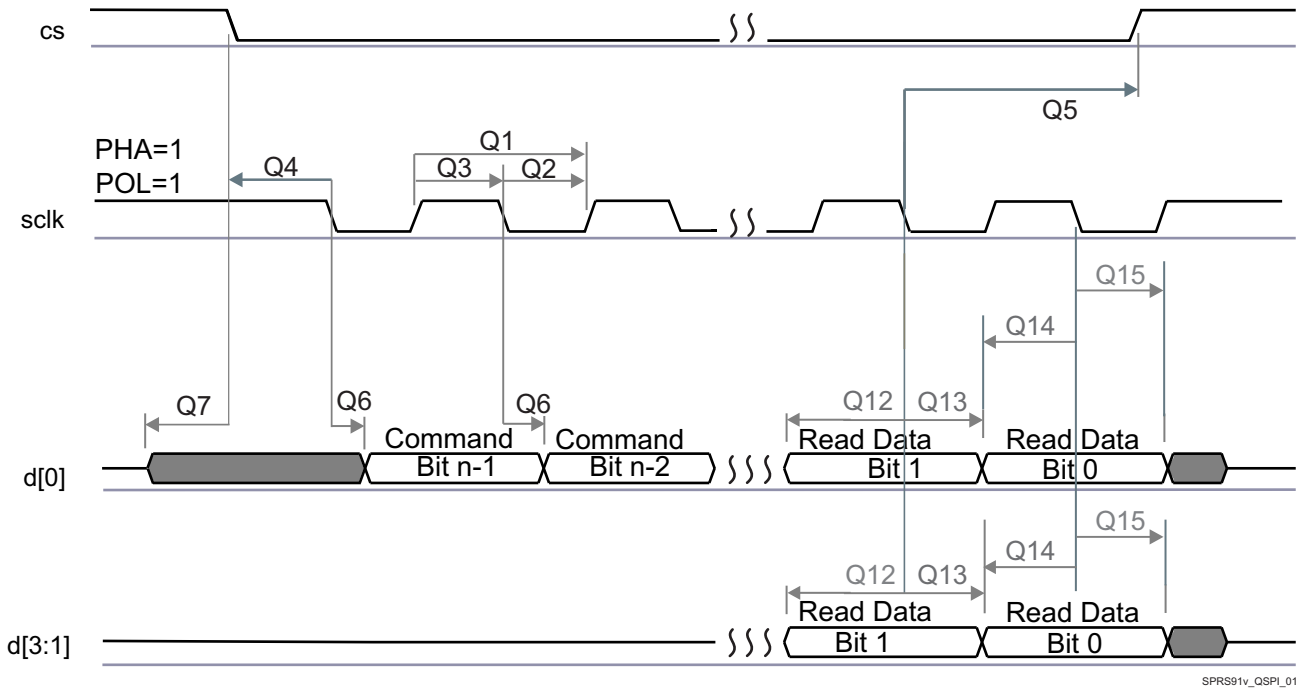
The IO Timings provided in this section are only valid for some QSPI usage modes when the corresponding Virtual IO Timings or Manual IO Timings are configured as described in the tables found in this section.

表 7-47. Timing Requirements for QSPI

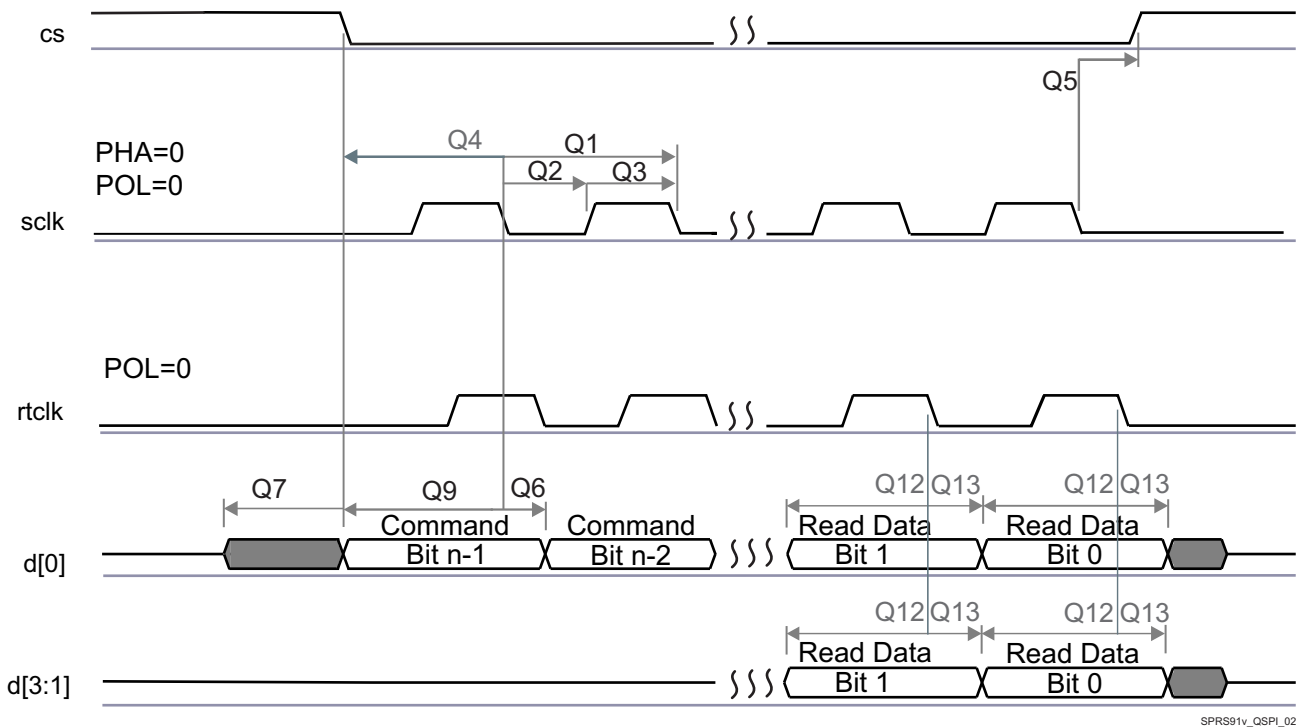
No	PARAMETER	DESCRIPTION	Mode	MIN	MAX	UNIT
Q12	$t_{su}(D-RTCLK)$	Setup time, d[3:0] valid before falling rtclk edge	Default Timing Mode, Clock Mode 0	5.1		ns
	$t_{su}(D-SCLK)$	Setup time, d[3:0] valid before falling sclk edge	Default Timing Mode, Clock Mode 3	12.3		ns
Q13	$t_h(RTCLK-D)$	Hold time, d[3:0] valid after falling rtclk edge	Default Timing Mode, Clock Mode 0	-0.1		ns
	$t_h(SCLK-D)$	Hold time, d[3:0] valid after falling sclk edge	Default Timing Mode, Clock Mode 3	0		ns
Q14	$t_{su}(D-SCLK)$	Setup time, final d[3:0] bit valid before final falling sclk edge	Default Timing Mode, Clock Mode 3	12.3-P (1)		ns
Q15	$t_h(SCLK-D)$	Hold time, final d[3:0] bit valid after final falling sclk edge	Default Timing Mode, Clock Mode 3	0+P (1)		ns

- (1) P = SCLK period.
- (2) Clock Modes 1 and 2 are not supported.
- (3) The Device captures data on the falling clock edge in Clock Mode 0 and 3, as opposed to the traditional rising clock edge. Although nonstandard, the falling-edge-based setup and hold time timings have been designed to be compatible with standard SPI devices that launch data on the falling edge in Clock Modes 0 and 3.

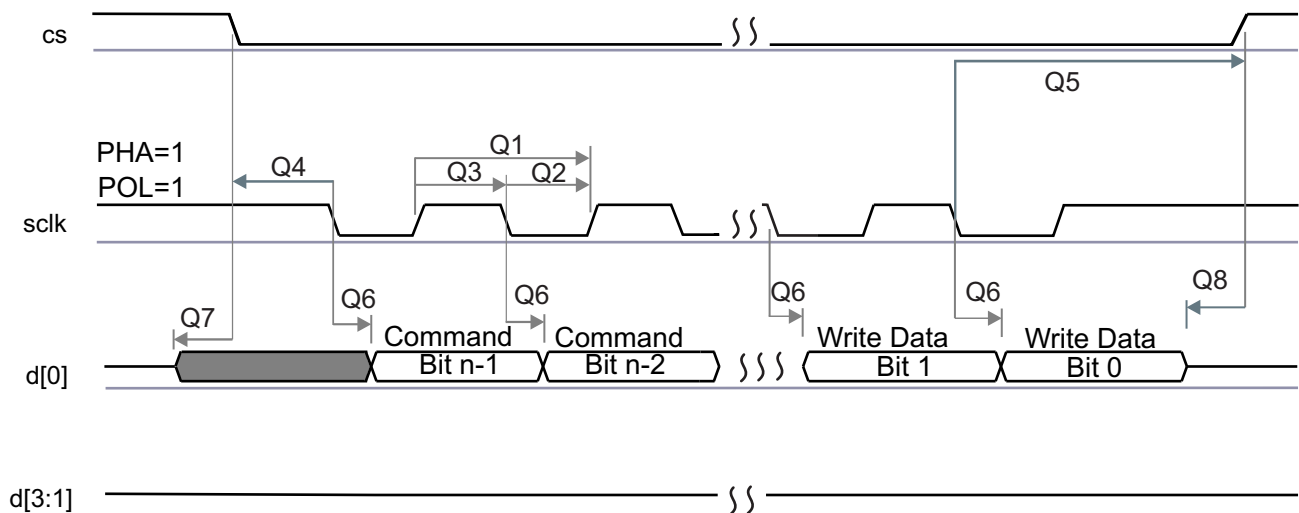

SPRS91v_QSPI_03

图 7-39. QSPI Write (Clock Mode 3)

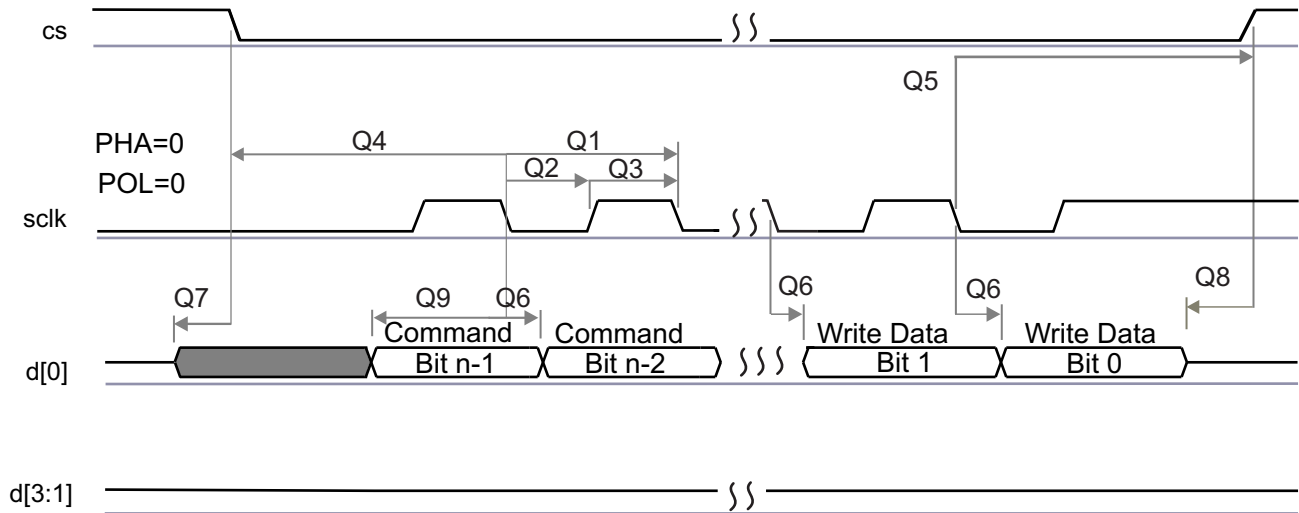

SPRS91v_QSPI_04

图 7-40. QSPI Write (Clock Mode 0)

注: To configure the desired Manual IO Timing Mode the user must follow the steps described in section Manual IO Timing Modes of the Device TRM.

The associated registers to configure are listed in the **CFG REGISTER** column. For more information see the Control Module chapter in the Device TRM.

Manual IO Timings Modes must be used to ensure some IO timings for QSPI. See 表 7-2 Modes Summary for a list of IO timings requiring the use of Manual IO Timings Modes. See 表 7-48 Manual Functions Mapping for QSPI for a definition of the Manual modes.

表 7-48 lists the A_DELAY and G_DELAY values needed to calculate the correct values to be set in the CFG_x registers.

表 7-48. Manual Functions Mapping for QSPI

BALL	BALL NAME	QSPI_MODE0_MANUAL1		CFG REGISTER	MUXMODE 1
		A_DELAY (ps)	G_DELAY (ps)		
T7	gpmc_a3	114	0	CFG_GPMC_A3_OUT	qspi1_cs2
P6	gpmc_a4	91	0	CFG_GPMC_A4_OUT	qspi1_cs3
R3	gpmc_a13	0	0	CFG_GPMC_A13_IN	qspi1_rclk
T2	gpmc_a14	2575	966	CFG_GPMC_A14_IN	qspi1_d3
U2	gpmc_a15	2503	889	CFG_GPMC_A15_IN	qspi1_d2
U1	gpmc_a16	2528	1007	CFG_GPMC_A16_IN	qspi1_d0
U1	gpmc_a16	0	0	CFG_GPMC_A16_OUT	qspi1_d0
P3	gpmc_a17	2533	980	CFG_GPMC_A17_IN	qspi1_d1
R2	gpmc_a18	590	0	CFG_GPMC_A18_OUT	qspi1_sclk
P2	gpmc_cs2	0	0	CFG_GPMC_CS2_OUT	qspi1_cs0
P1	gpmc_cs3	70	0	CFG_GPMC_CS3_OUT	qspi1_cs1

7.17 Multichannel Audio Serial Port (McASP)

The multichannel audio serial port (McASP) functions as a general-purpose audio serial port optimized for the needs of multichannel audio applications. The McASP is useful for time-division multiplexed (TDM) stream, Inter-Integrated Sound (I2S) protocols, and inter-component digital audio interface transmission (DIT).

The device have integrated 8 McASP modules (McASP1-McASP8) with:

- McASP1 and McASP2 modules supporting 16 channels with independent TX/RX clock/sync domain
- McASP3 through McASP8 modules supporting 4 channels with independent TX/RX clock/sync domain

注: For more information, see the Multichannel Audio Serial Port section of the Device TRM.

注意

The IO Timings provided in this section are only valid for some McASP usage modes when the corresponding Virtual IO Timings or Manual IO Timings are configured as described in the tables found in this section.

表 7-49, 表 7-50, 表 7-51 and 表 7-41 present Timing Requirements for McASP1 to McASP8.

表 7-49. Timing Requirements for McASP1 ⁽¹⁾

NO.	PARAMETER	DESCRIPTION	MODE	MIN	MAX	UNIT
1	$t_{c(AHCLKRX)}$	Cycle time, AHCLKR/X		20		ns
2	$t_{w(AHCLKRX)}$	Pulse duration, AHCLKR/X high or low		0.35P ⁽²⁾		ns
3	$t_{c(ACLKRX)}$	Cycle time, ACLKR/X		20		ns
4	$t_{w(ACLKRX)}$	Pulse duration, ACLKR/X high or low		0.5R - 3 ⁽³⁾		ns
5	$t_{su(AFSRX-ACLK)}$	Setup time, AFSR/X input valid before ACLKR/X	ACLKR/X int	20		ns
			ACLKR/X ext in ACLKR/X ext out	4		ns
6	$t_{h(ACLK-AFSRX)}$	Hold time, AFSR/X input valid after ACLKR/X	ACLKR/X int	-1		ns
			ACLKR/X ext in ACLKR/X ext out	2.21		ns
7	$t_{su(AXR-ACLK)}$	Setup time, AXR input valid before ACLKR/X	ACLKR/X int	21.9		ns
			ACLKR/X ext in ACLKR/X ext out	4.42		ns
8	$t_{h(ACLK-AXR)}$	Hold time, AXR input valid after ACLKR/X	ACLKR/X int	-1		ns
			ACLKR/X ext in ACLKR/X ext out	2.52		ns

- (1) ACLKR internal: ACLKRCTL.CLKRM=1, PDIR.ACLKR = 1
 ACLKR external input: ACLKRCTL.CLKRM=0, PDIR.ACLKR=0
 ACLKR external output: ACLKRCTL.CLKRM=0, PDIR.ACLKR=1
 ACLKX internal: ACLKXCTL.CLKXM=1, PDIR.ACLKX = 1
 ACLKX external input: ACLKXCTL.CLKXM=0, PDIR.ACLKX=0
 ACLKX external output: ACLKXCTL.CLKXM=0, PDIR.ACLKX=1

(2) P = AHCLKR/X period in ns.

(3) R = ACLKR/X period in ns.

表 7-50. Timing Requirements for McASP2 ⁽¹⁾

NO.	PARAMETER	DESCRIPTION	MODE	MIN	MAX	UNIT
1	$t_{c(AHCLKRX)}$	Cycle time, AHCLKR/X		20		ns
2	$t_{w(AHCLKRX)}$	Pulse duration, AHCLKR/X high or low		0.35P ⁽²⁾		ns
3	$t_{c(ACLKRX)}$	Cycle time, ACLKR/X	Any Other Conditions	20		ns
			ACLKX/AFSX (In Sync Mode), ACLKR/AFSR (In Async Mode), and AXR are all inputs "80M" Virtual IO Timing Mode	12.5		ns
4	$t_{w(ACLKRX)}$	Pulse duration, ACLKR/X high or low	Any Other Conditions	0.5R - 3 ⁽³⁾		ns
			ACLKX/AFSX (In Sync Mode), ACLKR/AFSR (In Async Mode), and AXR are all inputs "80M" Virtual IO Timing Modes	0.38R ⁽³⁾		ns
5	$t_{su(AFSRX-ACLK)}$	Setup time, AFSR/X input valid before ACLKR/X	ACLKR/X int	20.7		ns
			ACLKR/X ext in ACLKR/X ext out	3.9		ns
			ACLKR/X ext in ACLKR/X ext out "80M" Virtual IO Timing Modes	3		ns

表 7-50. Timing Requirements for McASP2 ⁽¹⁾ (continued)

NO.	PARAMETER	DESCRIPTION	MODE	MIN	MAX	UNIT
6	$t_{h(ACLK-AFSRX)}$	Hold time, AFSR/X input valid after ACLKR/X	ACLKR/X int	-1		ns
			ACLKR/X ext in ACLKR/X ext out	3.2		ns
			ACLKR/X ext in ACLKR/X ext out "80M" Virtual IO Timing Modes	3		ns
7	$t_{su}(AXR-ACLK)$	Setup time, AXR input valid before ACLKR/X	ACLKR/X int	21.4		ns
			ACLKR/X ext in ACLKR/X ext out	3.9		ns
			ACLKR/X ext in ACLKR/X ext out "80M" Virtual IO Timing Modes	3		ns
8	$t_{h}(ACLK-AXR)$	Hold time, AXR input valid after ACLKR/X	ACLKR/X int	-1		ns
			ACLKR/X ext in ACLKR/X ext out	3.2		ns
			ACLKR/X ext in ACLKR/X ext out "80M" Virtual IO Timing Modes	3		ns

- (1) ACLKR internal: ACLKRCTL.CLKRM=1, PDIR.ACLKR = 1
 ACLKR external input: ACLKRCTL.CLKRM=0, PDIR.ACLKR=0
 ACLKR external output: ACLKRCTL.CLKRM=0, PDIR.ACLKR=1
 ACLKX internal: ACLKXCTL.CLKXM=1, PDIR.ACLKX = 1
 ACLKX external input: ACLKXCTL.CLKXM=0, PDIR.ACLKX=0
 ACLKX external output: ACLKXCTL.CLKXM=0, PDIR.ACLKX=1

(2) P = AHCLKR/X period in ns.

(3) R = ACLKR/X period in ns.

表 7-51. Timing Requirements for McASP3/4/5/6/7/8 ⁽¹⁾

NO.	PARAMETER	DESCRIPTION	MODE	MIN	MAX	UNIT
1	$t_c(AHCLKRX)$	Cycle time, AHCLKR/X		20		ns
2	$t_w(AHCLKRX)$	Pulse duration, AHCLKR/X high or low		0.35P ⁽²⁾		ns
3	$t_c(ACLKRX)$	Cycle time, ACLKR/X		20		ns
4	$t_w(ACLKRX)$	Pulse duration, ACLKR/X high or low		0.5R - 3 ⁽³⁾		ns
5	$t_{su}(AFSRX-ACLK)$	Setup time, AFSR/X input valid before ACLKR/X	ACLKR/X int	20.2		ns
			ACLKR/X ext in ACLKR/X ext out	4.9		ns
6	$t_{h}(ACLK-AFSRX)$	Hold time, AFSR/X input valid after ACLKR/X	ACLKR/X int	-1		ns
			ACLKR/X ext in ACLKR/X ext out	2.26		ns
	$t_{su}(AXR-ACLK)$	Setup time, AXR input valid before ACLKX	ACLKX int (ASYNC=0)	20.8		ns
			ACLKR/X ext in ACLKR/X ext out	5.75		ns
8	$t_{h}(ACLK-AXR)$	Hold time, AXR input valid after ACLKX	ACLKX int (ASYNC=0)	-0.9		ns
			ACLKR/X ext in ACLKR/X ext out	2.87		ns

- (1) ACLKR internal: ACLKRCTL.CLKRM=1, PDIR.ACLKR = 1 (NOT SUPPORTED)
 ACLKR external input: ACLKRCTL.CLKRM=0, PDIR.ACLKR=0
 ACLKR external output: ACLKRCTL.CLKRM=0, PDIR.ACLKR=1
 ACLKX internal: ACLKXCTL.CLKXM=1, PDIR.ACLKX = 1
 ACLKX external input: ACLKXCTL.CLKXM=0, PDIR.ACLKX=0
 ACLKX external output: ACLKXCTL.CLKXM=0, PDIR.ACLKX=1
- (2) P = AHCLKR/X period in ns.
- (3) R = ACLKR/X period in ns.

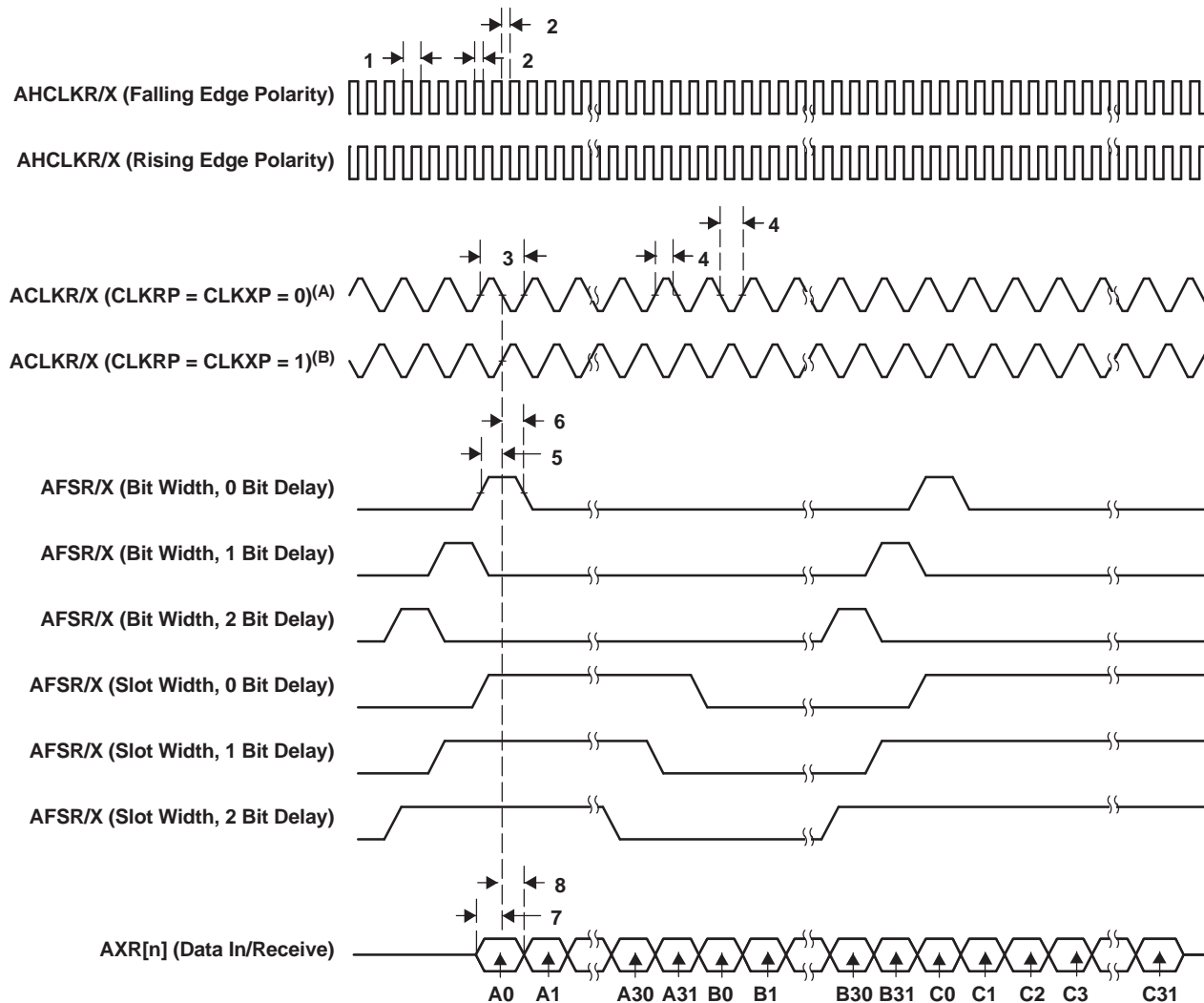

- A. For CLKRP = CLKXP = 0, the McASP transmitter is configured for rising edge (to shift data out) and the McASP receiver is configured for falling edge (to shift data in).
- B. For CLKRP = CLKXP = 1, the McASP transmitter is configured for falling edge (to shift data out) and the McASP receiver is configured for rising edge (to shift data in).

图 7-41. McASP Input Timing

注意

The IO Timings provided in this section are only valid for some McASP usage modes when the corresponding Virtual IO Timings or Manual IO Timings are configured as described in the tables found in this section.

表 7-52, 表 7-53, 表 7-54 和 图 7-42 present Switching Characteristics Over Recommended Operating Conditions for McASP1 to McASP8.

表 7-52. Switching Characteristics Over Recommended Operating Conditions for McASP1 ⁽¹⁾

NO.	PARAMETER	DESCRIPTION	MODE	MIN	MAX	UNIT
9	$t_{c(AHCLKRX)}$	Cycle time, AHCLKR/X		20		ns
10	$t_{w(AHCLKRX)}$	Pulse duration, AHCLKR/X high or low		0.5P - 2.5 ⁽²⁾		ns
11	$t_{c(ACLKRX)}$	Cycle time, ACLKR/X		20		ns
12	$t_{w(ACLKRX)}$	Pulse duration, ACLKR/X high or low		0.5P - 2.5 ⁽³⁾		ns
13	$t_{d(ACLK-AFSXR)}$	Delay time, ACLKR/X transmit edge to AFSX/R output valid	ACLKR/X int	-0.21	6	ns
			ACLKR/X ext in ACLKR/X ext out	2	23.9	ns
14	$t_{d(ACLK-AXR)}$	Delay time, ACLKR/X transmit edge to AXR output valid	ACLKR/X int	-1.8	6.9	ns
			ACLKR/X ext in ACLKR/X ext out	2	25.6	ns

- (1) ACLKR internal: ACLKRCTL.CLKRM=1, PDIR.ACLKR = 1
 ACLKR external input: ACLKRCTL.CLKRM=0, PDIR.ACLKR=0
 ACLKR external output: ACLKRCTL.CLKRM=0, PDIR.ACLKR=1
 ACLKX internal: ACLKXCTL.CLKXM=1, PDIR.ACLKX = 1
 ACLKX external input: ACLKXCTL.CLKXM=0, PDIR.ACLKX=0
 ACLKX external output: ACLKXCTL.CLKXM=0, PDIR.ACLKX=1

(2) P = AHCLKR/X period in ns.

(3) R = ACLKR/X period in ns.

表 7-53. Switching Characteristics Over Recommended Operating Conditions for McASP2 ⁽¹⁾

NO.	PARAMETER	DESCRIPTION	MODE	MIN	MAX	UNIT
9	$t_{c(AHCLKRX)}$	Cycle time, AHCLKR/X		20		ns
10	$t_{w(AHCLKRX)}$	Pulse duration, AHCLKR/X high or low		0.5P - 2.5 ⁽²⁾		ns
11	$t_{c(ACLKRX)}$	Cycle time, ACLKR/X		20		ns
12	$t_{w(ACLKRX)}$	Pulse duration, ACLKR/X high or low		0.5P - 2.5 ⁽³⁾		ns
13	$t_{d(ACLK-AFSXR)}$	Delay time, ACLKR/X transmit edge to AFSX/R output valid	ACLKR/X int	0	6	ns
			ACLKR/X ext in ACLKR/X ext out	2	25.2	ns
14	$t_{d(ACLK-AXR)}$	Delay time, ACLKR/X transmit edge to AXR output valid	ACLKR/X int	-1.29	6.11	ns
			ACLKR/X ext in ACLKR/X ext out	2	24.8	ns

- (1) ACLKR internal: ACLKRCTL.CLKRM=1, PDIR.ACLKR = 1
 ACLKR external input: ACLKRCTL.CLKRM=0, PDIR.ACLKR=0
 ACLKR external output: ACLKRCTL.CLKRM=0, PDIR.ACLKR=1
 ACLKX internal: ACLKXCTL.CLKXM=1, PDIR.ACLKX = 1
 ACLKX external input: ACLKXCTL.CLKXM=0, PDIR.ACLKX=0
 ACLKX external output: ACLKXCTL.CLKXM=0, PDIR.ACLKX=1

(2) P = AHCLKR/X period in ns.

(3) R = ACLKR/X period in ns.

表 7-54. Switching Characteristics Over Recommended Operating Conditions for McASP3/4/5/6/7/8 ⁽¹⁾

NO.	PARAMETER	DESCRIPTION	MODE	MIN	MAX	UNIT
9	$t_{c(AHCLKRX)}$	Cycle time, AHCLKR/X		20		ns

表 7-54. Switching Characteristics Over Recommended Operating Conditions for McASP3/4/5/6/7/8
⁽¹⁾ (continued)

NO.	PARAMETER	DESCRIPTION	MODE	MIN	MAX	UNIT
10	$t_{w(AHCLKRX)}$	Pulse duration, AHCLKR/X high or low		0.5P - 2.5 ⁽²⁾		ns
11	$t_c(ACLKRX)$	Cycle time, ACLKRX		20		ns
12	$t_w(ACLKRX)$	Pulse duration, ACLKRX high or low		0.5P - 2.5 ⁽³⁾		ns
13	$t_d(ACLK-AFSXR)$	Delay time, ACLKRX transmit edge to AFSX/R output valid	ACLKRX int	-0.74	6	ns
			ACLKRX ext in ACLKRX ext out	2	26.4	ns
14	$t_d(ACLK-AXR)$	Delay time, ACLKRX transmit edge to AXR output valid	ACLKRX int	-1.68	6.97	ns
			ACLKRX ext in ACLKRX ext out	1.07	25.9	ns

(1) ACLKR internal: ACLKRCTL.CLKRM=1, PDIR.ACLKR = 1
 ACLKR external input: ACLKRCTL.CLKRM=0, PDIR.ACLKR=0
 ACLKR external output: ACLKRCTL.CLKRM=0, PDIR.ACLKR=1
 ACLKX internal: ACLKXCTL.CLKXM=1, PDIR.ACLKX = 1
 ACLKX external input: ACLKXCTL.CLKXM=0, PDIR.ACLKX=0
 ACLKX external output: ACLKXCTL.CLKXM=0, PDIR.ACLKX=1

(2) P = AHCLKR/X period in ns.

(3) R = ACLKRX period in ns.

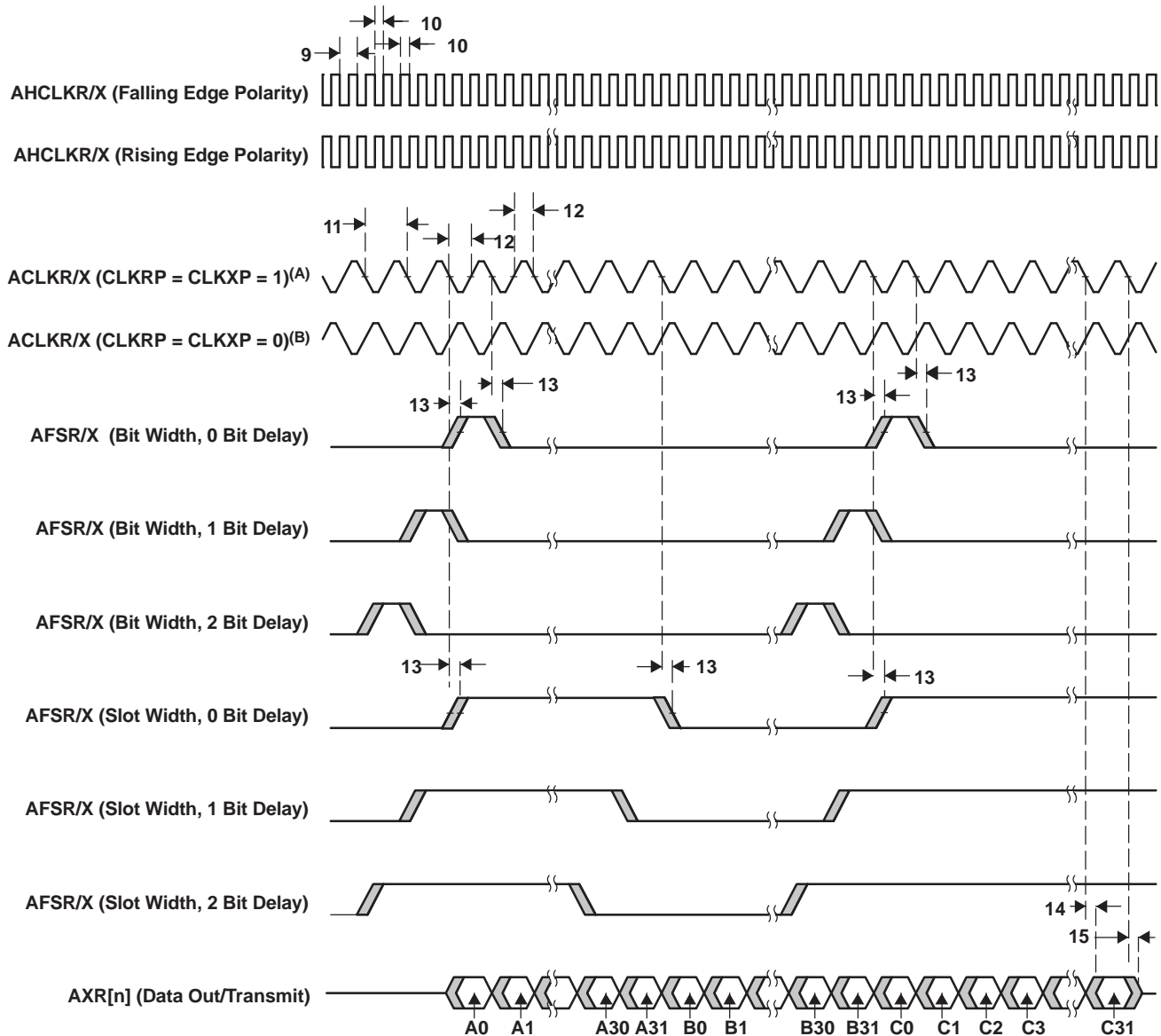

- A. For CLKRP = CLKXP = 1, the McASP transmitter is configured for falling edge (to shift data out) and the McASP receiver is configured for rising edge (to shift data in).
- B. For CLKRP = CLKXP = 0, the McASP transmitter is configured for rising edge (to shift data out) and the McASP receiver is configured for falling edge (to shift data in).

图 7-42. McASP Output Timing

注: To configure the desired virtual mode the user must set MODESELECT bit and DELAYMODE bitfield for each corresponding pad control register.

The pad control registers are presented in 表 4-3 and described in Device TRM, *Control Module Chapter*.

表 7-55 through 表 7-62 explain all cases with Virtual Mode Details for McASP1/2/3/4/5/6/7/8 (see 图 7-43 through 图 7-50).

表 7-55. Virtual Mode Case Details for McASP1

No.	CASE	CASE Description	Virtual Mode Settings		Notes
			Signals	Virtual Mode Value	
IP Mode : ASYNC					
1	COIFOI	CLKX / FSX: Output CLKR / FSR: Input	AXR(Outputs)/CLKX/FSX	Default (No Virtual Mode)	See 7-43
			AXR(Inputs)/CLKR/FSR	MCASP1_VIRTUAL3_ASYNC_RX	
2	COIFIO	CLKX / FSR: Output CLKR / FSX: Input	AXR(Outputs)/CLKX/FSX	Default (No Virtual Mode)	See 7-44
			AXR(Inputs)/CLKR/FSR	MCASP1_VIRTUAL3_ASYNC_RX	
3	CIOFIO	CLKR / FSR: Output CLKX / FSX: Input	AXR(Outputs)/CLKX/FSX	MCASP1_VIRTUAL3_ASYNC_RX	See 7-45
			AXR(Inputs)/CLKR/FSR	MCASP1_VIRTUAL1_ASYNC_TX	
4	CIOFOI	CLKR / FSX: Output CLKX / FSR: Input	AXR(Outputs)/CLKX/FSX	MCASP1_VIRTUAL3_ASYNC_RX	See 7-46
			AXR(Inputs)/CLKR/FSR	MCASP1_VIRTUAL1_ASYNC_TX	
IP Mode : SYNC (CLKR / FSR internally generated from CLKX / FSX)					
5	CO-FO-	CLKX / FSX: Output	AXR(Outputs)/CLKX/FSX	Default (No Virtual Mode)	See 7-47
			AXR(Inputs)/CLKX/FSX	Default (No Virtual Mode)	
6	CI-FO-	FSX: Output CLKX: Input	AXR(Outputs)/CLKX/FSX	MCASP1_VIRTUAL2_SYNC_RX	See 7-48
			AXR(Inputs)/CLKX/FSX	MCASP1_VIRTUAL2_SYNC_RX	
7	CI-FI-	CLKX / FSX: Input	AXR(Outputs)/CLKX/FSX	MCASP1_VIRTUAL2_SYNC_RX	See 7-49
			AXR(Inputs)/CLKX/FSX	MCASP1_VIRTUAL2_SYNC_RX	
8	CO-FI-	CLKX: Output FSX: Input	AXR(Outputs)/CLKX/FSX	Default (No Virtual Mode)	See 7-50
			AXR(Inputs)/CLKX/FSX	Default (No Virtual Mode)	

表 7-56. Virtual Mode Case Details for McASP2

No.	CASE	CASE Description	Virtual Mode Settings		Notes
			Signals	Virtual Mode Value	
IP Mode : ASYNC					
1	COIFOI	CLKX / FSX: Output CLKR / FSR: Input	AXR(Outputs)/CLKX/FSX	Default (No Virtual Mode) ⁽¹⁾	See 7-43
			AXR(Inputs)/CLKR/FSR	Default (No Virtual Mode) ⁽¹⁾	
			AXR(Inputs)/CLKR/FSR	MCASP2_VIRTUAL4_ASYNC_RX_80M ⁽²⁾	
2	COIFIO	CLKX / FSR: Output CLKR / FSX: Input	AXR(Outputs)/CLKX/FSX	Default (No Virtual Mode)	See 7-44
			AXR(Inputs)/CLKR/FSR	MCASP2_VIRTUAL2_ASYNC_RX	
3	CIOFIO	CLKR / FSR: Output CLKX / FSX: Input	AXR(Outputs)/CLKX/FSX	MCASP2_VIRTUAL2_ASYNC_RX	See 7-45
			AXR(Inputs)/CLKR/FSR	Default (No Virtual Mode)	
4	CIOFOI	CLKR / FSX: Output CLKX / FSR: Input	AXR(Outputs)/CLKX/FSX	MCASP2_VIRTUAL2_ASYNC_RX	See 7-46
			AXR(Inputs)/CLKR/FSR	Default (No Virtual Mode)	
IP Mode : SYNC (CLKR / FSR internally generated from CLKX / FSX)					
5	CO-FO-	CLKX / FSX: Output	AXR(Outputs)/CLKX/FSX	Default (No Virtual Mode)	See 7-47
			AXR(Inputs)/CLKX/FSX	Default (No Virtual Mode)	
6	CI-FO-	FSX: Output CLKX: Input	AXR(Outputs)/CLKX/FSX	MCASP2_VIRTUAL3_SYNC_RX	See 7-48
			AXR(Inputs)/CLKX/FSX	MCASP2_VIRTUAL3_SYNC_RX	
7	CI-FI-	CLKX / FSX: Input	AXR(Outputs)/CLKX/FSX	MCASP2_VIRTUAL3_SYNC_RX ⁽¹⁾	See 7-49
			AXR(Inputs)/CLKX/FSX	MCASP2_VIRTUAL3_SYNC_RX ⁽¹⁾	
			AXR(Inputs)/CLKX/FSX	MCASP2_VIRTUAL1_SYNC_RX_80M ⁽²⁾	
8	CO-FI-	CLKX: Output FSX: Input	AXR(Outputs)/CLKX/FSX	Default (No Virtual Mode)	See 7-50
			AXR(Inputs)/CLKX/FSX	Default (No Virtual Mode)	

- (1) Used up to 50MHz. Should also be used in a CI-FI- mixed case where AXR operate as both inputs and outputs (that is, AXR are bidirectional).
- (2) Used in 80MHz input only mode when AXR, CLKX and FSX are all inputs.

表 7-57. Virtual Mode Case Details for McASP3

No.	CASE	CASE Description	Virtual Mode Settings		Notes
			Signals	Virtual Mode Value	
IP Mode : ASYNC					
1	COIFOI	CLKX / FSX: Output CLKR / FSR: Input	AXR(Outputs)/CLKX/FSX	Default (No Virtual Mode)	See 图 7-43
			AXR(Inputs)/CLKR/FSR	MCASP3_VIRTUAL2_SYNC_RX	
2	COIFIO	CLKX / FSR: Output CLKR / FSX: Input	AXR(Outputs)/CLKX/FSX	Default (No Virtual Mode)	See 图 7-44
			AXR(Inputs)/CLKR/FSR	MCASP3_VIRTUAL2_SYNC_RX	
3	CIOFIO	CLKR / FSR: Output CLKX / FSX: Input	AXR(Outputs)/CLKX/FSX	MCASP3_VIRTUAL2_SYNC_RX	See 图 7-45
			AXR(Inputs)/CLKR/FSR	MCASP3_VIRTUAL2_SYNC_RX	
4	CIOFOI	CLKR / FSX: Output CLKX / FSR: Input	AXR(Outputs)/CLKX/FSX	MCASP3_VIRTUAL2_SYNC_RX	See 图 7-46
			AXR(Inputs)/CLKR/FSR	MCASP3_VIRTUAL2_SYNC_RX	
IP Mode : SYNC (CLKR / FSR internally generated from CLKX / FSX)					
5	CO-FO-	CLKX / FSX: Output	AXR(Outputs)/CLKX/FSX	Default (No Virtual Mode)	See 图 7-47
			AXR(Inputs)/CLKX/FSX	Default (No Virtual Mode)	
6	CI-FO-	FSX: Output CLKX: Input	AXR(Outputs)/CLKX/FSX	MCASP3_VIRTUAL2_SYNC_RX	See 图 7-48
			AXR(Inputs)/CLKX/FSX	MCASP3_VIRTUAL2_SYNC_RX	
7	CI-FI-	CLKX / FSX: Input	AXR(Outputs)/CLKX/FSX	MCASP3_VIRTUAL2_SYNC_RX	See 图 7-49
			AXR(Inputs)/CLKX/FSX	MCASP3_VIRTUAL2_SYNC_RX	
8	CO-FI-	CLKX: Output FSX: Input	AXR(Outputs)/CLKX/FSX	Default (No Virtual Mode)	See 图 7-50
			AXR(Inputs)/CLKX/FSX	Default (No Virtual Mode)	

表 7-58. Virtual Mode Case Details for McASP4

No.	CASE	CASE Description	Virtual Mode Settings		Notes
			Signals	Virtual Mode Value	
IP Mode : ASYNC					
1	COIFOI	CLKX / FSX: Output CLKR / FSR: Input	AXR(Outputs)/CLKX/FSX	Default (No Virtual Mode)	See 图 7-43
			AXR(Inputs)/CLKR/FSR	MCASP4_VIRTUAL1_SYNC_RX	
2	COIFIO	CLKX / FSR: Output CLKR / FSX: Input	AXR(Outputs)/CLKX/FSX	Default (No Virtual Mode)	See 图 7-44
			AXR(Inputs)/CLKR/FSR	MCASP4_VIRTUAL1_SYNC_RX	
3	CIOFIO	CLKR / FSR: Output CLKX / FSX: Input	AXR(Outputs)/CLKX/FSX	MCASP4_VIRTUAL1_SYNC_RX	See 图 7-45
			AXR(Inputs)/CLKR/FSR	MCASP4_VIRTUAL1_SYNC_RX	
4	CIOFOI	CLKR / FSX: Output CLKX / FSR: Input	AXR(Outputs)/CLKX/FSX	MCASP4_VIRTUAL1_SYNC_RX	See 图 7-46
			AXR(Inputs)/CLKR/FSR	MCASP4_VIRTUAL1_SYNC_RX	
IP Mode : SYNC (CLKR / FSR internally generated from CLKX / FSX)					
5	CO-FO-	CLKX / FSX: Output	AXR(Outputs)/CLKX/FSX	Default (No Virtual Mode)	See 图 7-47
			AXR(Inputs)/CLKX/FSX	Default (No Virtual Mode)	
6	CI-FO-	FSX: Output CLKX: Input	AXR(Outputs)/CLKX/FSX	MCASP4_VIRTUAL1_SYNC_RX	See 图 7-48
			AXR(Inputs)/CLKX/FSX	MCASP4_VIRTUAL1_SYNC_RX	
7	CI-FI-	CLKX / FSX: Input	AXR(Outputs)/CLKX/FSX	MCASP4_VIRTUAL1_SYNC_RX	See 图 7-49
			AXR(Inputs)/CLKX/FSX	MCASP4_VIRTUAL1_SYNC_RX	
8	CO-FI-	CLKX: Output FSX: Input	AXR(Outputs)/CLKX/FSX	Default (No Virtual Mode)	See 图 7-50
			AXR(Inputs)/CLKX/FSX	Default (No Virtual Mode)	

表 7-59. Virtual Mode Case Details for McASP5

No.	CASE	CASE Description	Virtual Mode Settings		Notes
			Signals	Virtual Mode Value	
IP Mode : ASYNC					
1	COIFOI	CLKX / FSX: Output CLKR / FSR: Input	AXR(Outputs)/CLKX/FSX	Default (No Virtual Mode)	See 7-43
			AXR(Inputs)/CLKR/FSR	MCASP5_VIRTUAL1_SYNC_RX	
2	COIFIO	CLKX / FSR: Output CLKR / FSX: Input	AXR(Outputs)/CLKX/FSX	Default (No Virtual Mode)	See 7-44
			AXR(Inputs)/CLKR/FSR	MCASP5_VIRTUAL1_SYNC_RX	
3	CIOFIO	CLKR / FSR: Output CLKX / FSX: Input	AXR(Outputs)/CLKX/FSX	MCASP5_VIRTUAL1_SYNC_RX	See 7-45
			AXR(Inputs)/CLKR/FSR	MCASP5_VIRTUAL1_SYNC_RX	
4	CIOFOI	CLKR / FSX: Output CLKX / FSR: Input	AXR(Outputs)/CLKX/FSX	MCASP5_VIRTUAL1_SYNC_RX	See 7-46
			AXR(Inputs)/CLKR/FSR	MCASP5_VIRTUAL1_SYNC_RX	
IP Mode : SYNC (CLKR / FSR internally generated from CLKX / FSX)					
5	CO-FO-	CLKX / FSX: Output	AXR(Outputs)/CLKX/FSX	Default (No Virtual Mode)	See 7-47
			AXR(Inputs)/CLKX/FSX	Default (No Virtual Mode)	
6	CI-FO-	FSX: Output CLKX: Input	AXR(Outputs)/CLKX/FSX	MCASP5_VIRTUAL1_SYNC_RX	See 7-48
			AXR(Inputs)/CLKX/FSX	MCASP5_VIRTUAL1_SYNC_RX	
7	CI-FI-	CLKX / FSX: Input	AXR(Outputs)/CLKX/FSX	MCASP5_VIRTUAL1_SYNC_RX	See 7-49
			AXR(Inputs)/CLKX/FSX	MCASP5_VIRTUAL1_SYNC_RX	
8	CO-FI-	CLKX: Output FSX: Input	AXR(Outputs)/CLKX/FSX	Default (No Virtual Mode)	See 7-50
			AXR(Inputs)/CLKX/FSX	Default (No Virtual Mode)	

表 7-60. Virtual Mode Case Details for McASP6

No.	CASE	CASE Description	Virtual Mode Settings		Notes
			Signals	Virtual Mode Value	
IP Mode : ASYNC					
1	COIFOI	CLKX / FSX: Output CLKR / FSR: Input	AXR(Outputs)/CLKX/FSX	Default (No Virtual Mode)	See 7-43
			AXR(Inputs)/CLKR/FSR	MCASP6_VIRTUAL1_SYNC_RX	
2	COIFIO	CLKX / FSR: Output CLKR / FSX: Input	AXR(Outputs)/CLKX/FSX	Default (No Virtual Mode)	See 7-44
			AXR(Inputs)/CLKR/FSR	MCASP6_VIRTUAL1_SYNC_RX	
3	CIOFIO	CLKR / FSR: Output CLKX / FSX: Input	AXR(Outputs)/CLKX/FSX	MCASP6_VIRTUAL1_SYNC_RX	See 7-45
			AXR(Inputs)/CLKR/FSR	MCASP6_VIRTUAL1_SYNC_RX	
4	CIOFOI	CLKR / FSX: Output CLKX / FSR: Input	AXR(Outputs)/CLKX/FSX	MCASP6_VIRTUAL1_SYNC_RX	See 7-46
			AXR(Inputs)/CLKR/FSR	MCASP6_VIRTUAL1_SYNC_RX	
IP Mode : SYNC (CLKR / FSR internally generated from CLKX / FSX)					
5	CO-FO-	CLKX / FSX: Output	AXR(Outputs)/CLKX/FSX	Default (No Virtual Mode)	See 7-47
			AXR(Inputs)/CLKX/FSX	Default (No Virtual Mode)	
6	CI-FO-	FSX: Output CLKX: Input	AXR(Outputs)/CLKX/FSX	MCASP6_VIRTUAL1_SYNC_RX	See 7-48
			AXR(Inputs)/CLKX/FSX	MCASP6_VIRTUAL1_SYNC_RX	
7	CI-FI-	CLKX / FSX: Input	AXR(Outputs)/CLKX/FSX	MCASP6_VIRTUAL1_SYNC_RX	See 7-49
			AXR(Inputs)/CLKX/FSX	MCASP6_VIRTUAL1_SYNC_RX	
8	CO-FI-	CLKX: Output FSX: Input	AXR(Outputs)/CLKX/FSX	Default (No Virtual Mode)	See 7-50
			AXR(Inputs)/CLKX/FSX	Default (No Virtual Mode)	

表 7-61. Virtual Mode Case Details for McASP7

No.	CASE	CASE Description	Virtual Mode Settings		Notes
			Signals	Virtual Mode Value	
IP Mode : ASYNC					
1	COIFOI	CLKX / FSX: Output CLKR / FSR: Input	AXR(Outputs)/CLKX/FSX	Default (No Virtual Mode)	See 图 7-43
			AXR(Inputs)/CLKR/FSR	MCASP7_VIRTUAL2_SYNC_RX	
2	COIFIO	CLKX / FSR: Output CLKR / FSX: Input	AXR(Outputs)/CLKX/FSX	Default (No Virtual Mode)	See 图 7-44
			AXR(Inputs)/CLKR/FSR	MCASP7_VIRTUAL2_SYNC_RX	
3	CIOFIO	CLKR / FSR: Output CLKX / FSX: Input	AXR(Outputs)/CLKX/FSX	MCASP7_VIRTUAL2_SYNC_RX	See 图 7-45
			AXR(Inputs)/CLKR/FSR	MCASP7_VIRTUAL2_SYNC_RX	
4	CIOFOI	CLKR / FSX: Output CLKX / FSR: Input	AXR(Outputs)/CLKX/FSX	MCASP7_VIRTUAL2_SYNC_RX	See 图 7-46
			AXR(Inputs)/CLKR/FSR	MCASP7_VIRTUAL2_SYNC_RX	
IP Mode : SYNC (CLKR / FSR internally generated from CLKX / FSX)					
5	CO-FO-	CLKX / FSX: Output	AXR(Outputs)/CLKX/FSX	Default (No Virtual Mode)	See 图 7-47
			AXR(Inputs)/CLKX/FSX	Default (No Virtual Mode)	
6	CI-FO-	FSX: Output CLKX: Input	AXR(Outputs)/CLKX/FSX	MCASP7_VIRTUAL2_SYNC_RX	See 图 7-48
			AXR(Inputs)/CLKX/FSX	MCASP7_VIRTUAL2_SYNC_RX	
7	CI-FI-	CLKX / FSX: Input	AXR(Outputs)/CLKX/FSX	MCASP7_VIRTUAL2_SYNC_RX	See 图 7-49
			AXR(Inputs)/CLKX/FSX	MCASP7_VIRTUAL2_SYNC_RX	
8	CO-FI-	CLKX: Output FSX: Input	AXR(Outputs)/CLKX/FSX	Default (No Virtual Mode)	See 图 7-50
			AXR(Inputs)/CLKX/FSX	Default (No Virtual Mode)	

表 7-62. Virtual Mode Case Details for McASP8

No.	CASE	CASE Description	Virtual Mode Settings		Notes
			Signals	Virtual Mode Value	
IP Mode : ASYNC					
1	COIFOI	CLKX / FSX: Output CLKR / FSR: Input	AXR(Outputs)/CLKX/FSX	Default (No Virtual Mode)	See 图 7-43
			AXR(Inputs)/CLKR/FSR	MCASP8_VIRTUAL1_SYNC_RX	
2	COIFIO	CLKX / FSR: Output CLKR / FSX: Input	AXR(Outputs)/CLKX/FSX	Default (No Virtual Mode)	See 图 7-44
			AXR(Inputs)/CLKR/FSR	MCASP8_VIRTUAL1_SYNC_RX	
3	CIOFIO	CLKR / FSR: Output CLKX / FSX: Input	AXR(Outputs)/CLKX/FSX	MCASP8_VIRTUAL1_SYNC_RX	See 图 7-45
			AXR(Inputs)/CLKR/FSR	MCASP8_VIRTUAL1_SYNC_RX	
4	CIOFOI	CLKR / FSX: Output CLKX / FSR: Input	AXR(Outputs)/CLKX/FSX	MCASP8_VIRTUAL1_SYNC_RX	See 图 7-46
			AXR(Inputs)/CLKR/FSR	MCASP8_VIRTUAL1_SYNC_RX	
IP Mode : SYNC (CLKR / FSR internally generated from CLKX / FSX)					
5	CO-FO-	CLKX / FSX: Output	AXR(Outputs)/CLKX/FSX	Default (No Virtual Mode)	See 图 7-47
			AXR(Inputs)/CLKX/FSX	Default (No Virtual Mode)	
6	CI-FO-	FSX: Output CLKX: Input	AXR(Outputs)/CLKX/FSX	MCASP8_VIRTUAL1_SYNC_RX	See 图 7-48
			AXR(Inputs)/CLKX/FSX	MCASP8_VIRTUAL1_SYNC_RX	
7	CI-FI-	CLKX / FSX: Input	AXR(Outputs)/CLKX/FSX	MCASP8_VIRTUAL1_SYNC_RX	See 图 7-49
			AXR(Inputs)/CLKX/FSX	MCASP8_VIRTUAL1_SYNC_RX	
8	CO-FI-	CLKX: Output FSX: Input	AXR(Outputs)/CLKX/FSX	Default (No Virtual Mode)	See 图 7-50
			AXR(Inputs)/CLKX/FSX	Default (No Virtual Mode)	

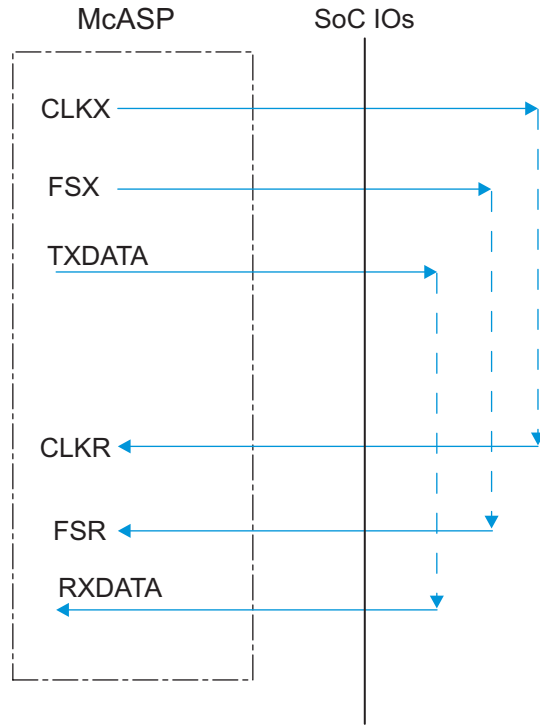

7-43. McASP1-8 COIFOI – ASYNC Mode

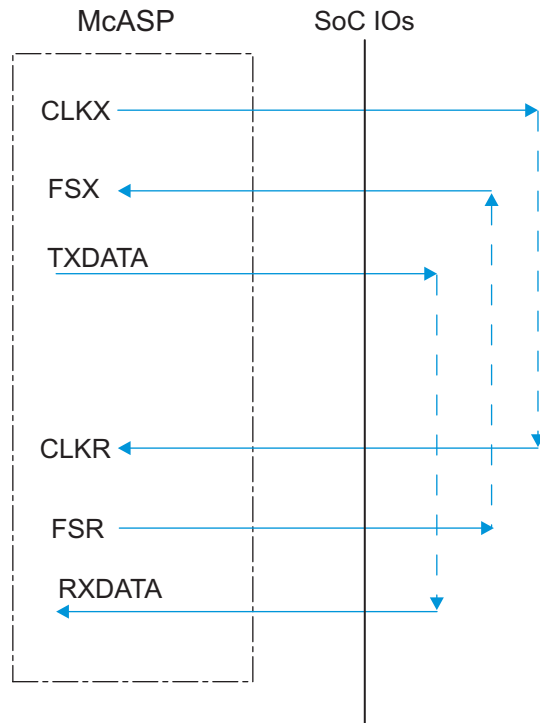

7-44. McASP1-8 COIFIO – ASYNC Mode

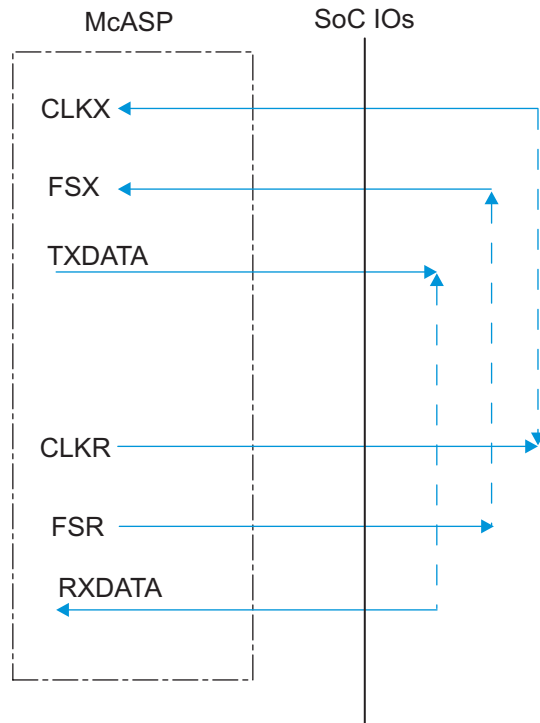

7-45. McASP1-8 CIOFIO – ASYNC Mode

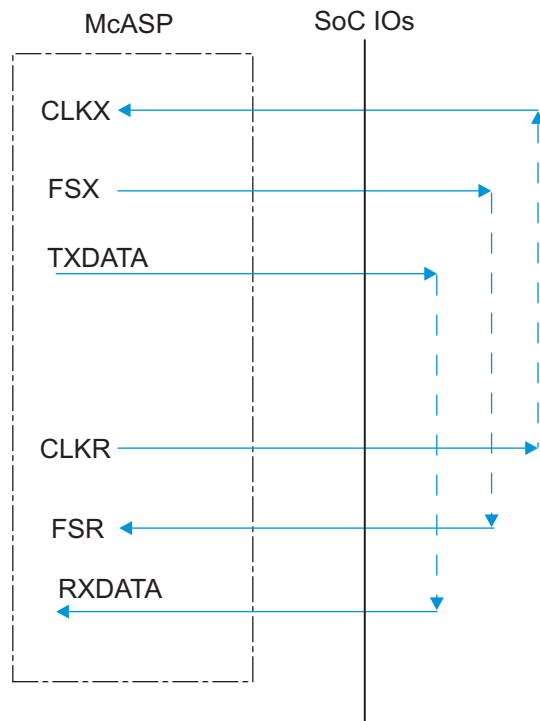

7-46. McASP1-8 CIOFOI – ASYNC Mode



图 7-47. McASP1-8 CO-FO- – SYNC Mode



图 7-48. McASP1-8 CI-FO- – SYNC Mode

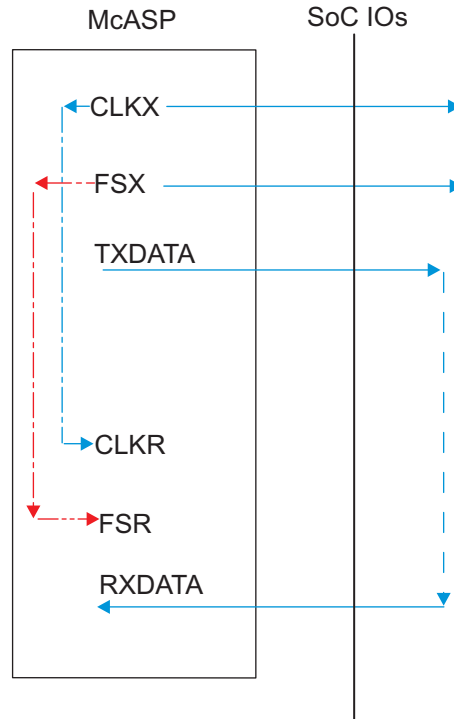

图 7-49. McASP1-8 CI-FI – SYNC Mode

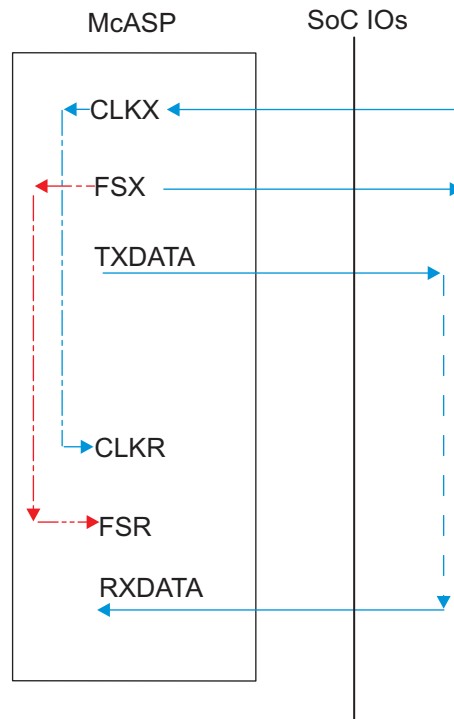

图 7-50. McASP1-8 CO-FI – SYNC Mode

Virtual IO Timings Modes must be used to ensure some IO timings for McASP1. See [表 7-2 Modes Summary](#) for a list of IO timings requiring the use of Virtual IO Timings Modes. See [表 7-63 Virtual Functions Mapping for McASP1](#) for a definition of the Virtual modes.

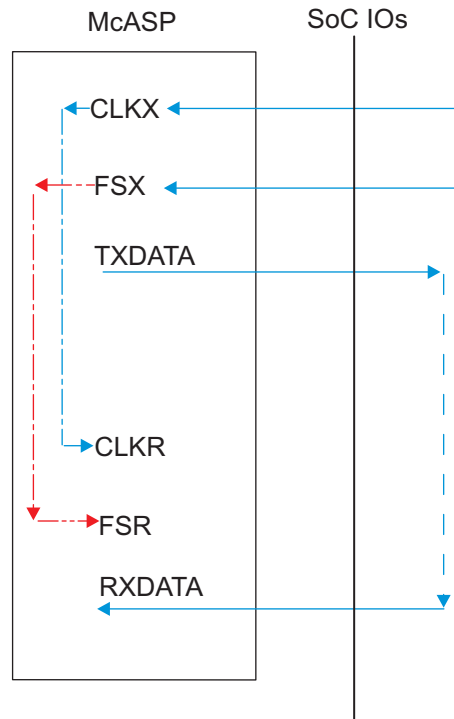
[表 7-63](#) presents the values for DELAYMODE bitfield.

表 7-63. Virtual Functions Mapping for McASP1

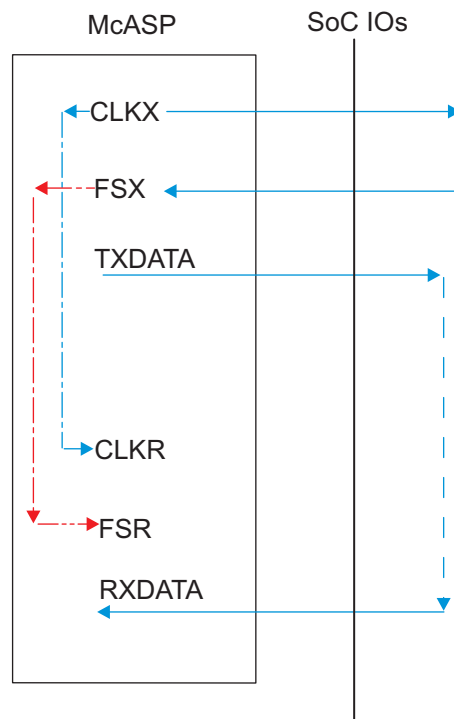
BALL	BALL NAME	Delay Mode Value			MUXMODE[15:0]		
		MCASP1_VIRTUAL1_AS YNC_TX	MCASP1_VIRTUAL2_SY NC_RX	MCASP1_VIRTUAL3_AS YNC_RX	0	1	2
E21	gpio6_14	11	15	14		mcasp1_axr8	
F20	gpio6_15	11	15	14		mcasp1_axr9	
F21	gpio6_16	11	15	14		mcasp1_axr10	
D18	xref_clk0	0	15	14			mcasp1_axr4
E17	xref_clk1	0	15	14			mcasp1_axr5
B26	xref_clk2	5	15	14			mcasp1_axr6
C23	xref_clk3	5	15	14			mcasp1_axr7
C14	mcasp1_aclkx	8	15	14	mcasp1_aclkx		
D14	mcasp1_fsx	12	15	14	mcasp1_fsx		
B14	mcasp1_aclkr	11	N/A	15	mcasp1_aclkr		
J14	mcasp1_fsr	11	N/A	15	mcasp1_fsr		
G12	mcasp1_axr0	8	15	14	mcasp1_axr0		
F12	mcasp1_axr1	8	15	14	mcasp1_axr1		
G13	mcasp1_axr2	10	15	14	mcasp1_axr2		
J11	mcasp1_axr3	10	15	14	mcasp1_axr3		
E12	mcasp1_axr4	10	15	14	mcasp1_axr4		
F13	mcasp1_axr5	10	15	14	mcasp1_axr5		
C12	mcasp1_axr6	10	15	14	mcasp1_axr6		
D12	mcasp1_axr7	10	15	14	mcasp1_axr7		
B12	mcasp1_axr8	6	15	14	mcasp1_axr8		
A11	mcasp1_axr9	6	15	14	mcasp1_axr9		
B13	mcasp1_axr10	6	15	14	mcasp1_axr10		
A12	mcasp1_axr11	6	15	14	mcasp1_axr11		
E14	mcasp1_axr12	6	15	14	mcasp1_axr12		
A13	mcasp1_axr13	6	15	14	mcasp1_axr13		
G14	mcasp1_axr14	6	15	14	mcasp1_axr14		
F14	mcasp1_axr15	6	15	14	mcasp1_axr15		

1. NA in this table stands for Not Applicable.

Virtual IO Timings Modes must be used to ensure some IO timings for McASP2. See 表 7-2 Modes Summary for a list of IO timings requiring the use of Virtual IO Timings Modes. See 表 7-64 Virtual Functions Mapping for McASP2 for a definition of the Virtual modes.

表 7-64 presents the values for DELAYMODE bitfield.

表 7-64. Virtual Functions Mapping for McASP2

BALL	BALL NAME	Delay Mode Value					MUXMODE[15:0]		
		MCASP2_VIRTUAL1_ASYNC_RX_80M	MCASP2_VIRTUAL2_ASYNC_RX	MCASP2_VIRTUAL3_ASYNC_TX	MCASP2_VIRTUAL4_SYNC_RX	MCASP2_VIRTUAL5_SYNC_RX_80M	0	1	2
D18	xref_clk0	10	9	4	8	6		mcasp2_axr8	
E17	xref_clk1	10	9	4	8	6		mcasp2_axr9	
B26	xref_clk2	13	12	0	11	10		mcasp2_axr10	
C23	xref_clk3	13	12	0	11	10		mcasp2_axr11	
A19	mcasp2_aclkx	15	14	5	10	9	mcasp2_aclkx		
A18	mcasp2_fsx	15	14	5	10	9	mcasp2_fsx		
E15	mcasp2_aclkr	15	14	10	N/A	N/A	mcasp2_aclkr		
A20	mcasp2_fsr	15	14	10	N/A	N/A	mcasp2_fsr		
B15	mcasp2_axr0	15	14	9	13	12	mcasp2_axr0		
A15	mcasp2_axr1	15	14	9	13	12	mcasp2_axr1		
C15	mcasp2_axr2	15	14	4	10	9	mcasp2_axr2		
A16	mcasp2_axr3	15	14	4	10	9	mcasp2_axr3		
D15	mcasp2_axr4	15	14	7	13	12	mcasp2_axr4		
B16	mcasp2_axr5	15	14	7	13	12	mcasp2_axr5		
B17	mcasp2_axr6	15	14	7	13	12	mcasp2_axr6		
A17	mcasp2_axr7	15	14	7	13	12	mcasp2_axr7		
B18	mcasp3_aclkx	15	14	5	10	9			mcasp2_axr12
F15	mcasp3_fsx	15	14	4	10	9			mcasp2_axr13
B19	mcasp3_axr0	15	14	4	10	9			mcasp2_axr14
C17	mcasp3_axr1	15	14	3	10	8			mcasp2_axr15

1. NA in this table stands for Not Applicable.

Virtual IO Timings Modes must be used to ensure some IO timings for McASP3/4/5/6/7/8. See 表 7-2 Modes Summary for a list of IO timings requiring the use of Virtual IO Timings Modes. See 表 7-65 Virtual Functions Mapping for McASP3/4/5/6/7/8 for a definition of the Virtual modes.

表 7-65 presents the values for DELAYMODE bitfield.

表 7-65. Virtual Functions Mapping for McASP3/4/5/6/7/8

BALL	BALL NAME	Delay Mode Value	MUXMODE[15:0]		
			0	1	2
		MCASP3_VIRTUAL2_SYNC_RX			

表 7-65. Virtual Functions Mapping for McASP3/4/5/6/7/8 (continued)

BALL	BALL NAME	Delay Mode Value	MUXMODE[15:0]		
			0	1	2
C15	mcasp2_axr2	8		mcasp3_axr2	
A16	mcasp2_axr3	8		mcasp3_axr3	
B18	mcasp3_aclkx	8	mcasp3_aclkx	mcasp3_aclkr	
F15	mcasp3_fsx	8	mcasp3_fsx	mcasp3_fsr	
B19	mcasp3_axr0	8	mcasp3_axr0		
C17	mcasp3_axr1	6	mcasp3_axr1		
MCASP4_VIRTUAL1_SYNC_RX					
E12	mcasp1_axr4	13		mcasp4_axr2	
F13	mcasp1_axr5	13		mcasp4_axr3	
C18	mcasp4_aclkx	15	mcasp4_aclkx	mcasp4_aclkr	
A21	mcasp4_fsx	15	mcasp4_fsx	mcasp4_fsr	
G16	mcasp4_axr0	15	mcasp4_axr0		
D17	mcasp4_axr1	15	mcasp4_axr1		
MCASP5_VIRTUAL1_SYNC_RX					
C12	mcasp1_axr6	13		mcasp5_axr2	
D12	mcasp1_axr7	13		mcasp5_axr3	
AA3	mcasp5_aclkx	15	mcasp5_aclkx	mcasp5_aclkr	
AB9	mcasp5_fsx	15	mcasp5_fsx	mcasp5_fsr	
AB3	mcasp5_axr0	15	mcasp5_axr0		
AA4	mcasp5_axr1	15	mcasp5_axr1		
MCASP6_VIRTUAL1_SYNC_RX					
G13	mcasp1_axr2	13		mcasp6_axr2	
J11	mcasp1_axr3	13		mcasp6_axr3	
B12	mcasp1_axr8	10		mcasp6_axr0	
A11	mcasp1_axr9	10		mcasp6_axr1	
B13	mcasp1_axr10	10		mcasp6_aclkx	mcasp6_aclkr
A12	mcasp1_axr11	10		mcasp6_fsx	mcasp6_fsr
MCASP7_VIRTUAL2_SYNC_RX					
B14	mcasp1_aclkr	14		mcasp7_axr2	
J14	mcasp1_fsr	14		mcasp7_axr3	
E14	mcasp1_axr12	10		mcasp7_axr0	
A13	mcasp1_axr13	10		mcasp7_axr1	

表 7-65. Virtual Functions Mapping for McASP3/4/5/6/7/8 (continued)

BALL	BALL NAME	Delay Mode Value	MUXMODE[15:0]		
			0	1	2
G14	mcasp1_axr14	10		mcasp7_aclkx	mcasp7_aclkr
F14	mcasp1_axr15	10		mcasp7_fsx	mcasp7_fsr
MCASP8_VIRTUAL1_SYNC_RX					
E15	mcasp2_aclkr	13		mcasp8_axr2	
A20	mcasp2_fsr	13		mcasp8_axr3	
D15	mcasp2_axr4	11		mcasp8_axr0	
B16	mcasp2_axr5	11		mcasp8_axr1	
B17	mcasp2_axr6	11		mcasp8_aclkx	mcasp8_aclkr
A17	mcasp2_axr7	11		mcasp8_fsx	mcasp8_fsr

7.18 Universal Serial Bus (USB)

SuperSpeed USB DRD Subsystem has four instances in the device providing the following functions:

- USB1: SuperSpeed (SS) USB 3.0 Dual-Role-Device (DRD) subsystem with integrated SS (USB3.0) PHY and HS/FS (USB2.0) PHY.
- USB2: High-Speed (HS) USB 2.0 Dual-Role-Device (DRD) subsystem with integrated HS/FS PHY.
- USB3: HS USB 2.0 Dual-Role-Device (DRD) subsystem with ULPI (SDR) interface to external HS/FS PHYs.
- USB4: HS USB 2.0 Dual-Role-Device (DRD) subsystem with ULPI (SDR) interface to external HS/FS PHYs.

注: For more information, see the SuperSpeed USB DRD section of the Device TRM.

7.18.1 USB1 DRD PHY

The USB1 DRD interface supports the following applications:

- USB2.0 High-Speed PHY port (1.8 V and 3.3 V): this asynchronous high-speed interface is compliant with the USB2.0 PHY standard with an internal transceiver (USB2.0 standard v2.0), for a maximum data rate of 480 Mbps.
- USB3.0 Super-Speed PHY port (1.8 V): this asynchronous differential super-speed interface is compliant with the USB3.0 RX/TX PHY standard (USB3.0 standard v1.0) for a maximum data bit rate of 5Gbps.

7.18.2 USB2 PHY

The USB2 interface supports the following applications:

- USB2.0 High-Speed PHY port (1.8 V and 3.3 V): this asynchronous high-speed interface is compliant with the USB2.0 PHY standard with an internal transceiver (USB2.0 standard v2.0), for a maximum data rate of 480 Mbps.

7.18.3 USB3 and USB4 DRD ULPI—SDR—Slave Mode—12-pin Mode

The USB3 and USB4 DRD interfaces support the following application:

- USB ULPI port: this synchronous interface is compliant with the USB2.0 ULPI SDR standard (UTMI+ v1.22), for alternative off-chip USB2.0 PHY interface; that is, with external transceiver with a maximum frequency of 60 MHz (synchronous slave mode, SDR, 12-pin, 8-data-bit).

注: The Universal Serial Bus k ULPI modules are also referred as USBk where k = 3, 4.

表 7-66, 表 7-67 和 图 7-51 assume testing over the recommended operating conditions and electrical characteristic conditions.

表 7-66. Timing Requirements for ULPI SDR Slave Mode

NO.	PARAMETER	DESCRIPTION	MIN	MAX	UNIT
US1	$t_{c(\text{clk})}$	Cycle time, usb_ulpi_clk period	16.66		ns
US5	$t_{su(\text{ctrlV-clkH})}$	Setup time, usb_ulpi_dir/usb_ulpi_nxt valid before usb_ulpi_clk rising edge	6.73		ns
US6	$t_{h(\text{clkH-ctrlV})}$	Hold time, usb_ulpi_dir/usb_ulpi_nxt valid after usb_ulpi_clk rising edge	-0.41		ns
US7	$t_{su(\text{dV-clkH})}$	Setup time, usb_ulpi_d[7:0] valid before usb_ulpi_clk rising edge	6.73		ns
US8	$t_{h(\text{clkH-dV})}$	Hold time, usb_ulpi_d[7:0] valid after usb_ulpi_clk rising edge	-0.41		ns

表 7-67. Switching Characteristics for ULPI SDR Slave Mode

NO.	PARAMETER	DESCRIPTION	MIN	MAX	UNIT
US4	$t_{d(\text{clkH-stpV})}$	Delay time, usb_ulpi_clk rising edge high to output usb_ulpi_stp valid	0.44	8.35	ns
US9	$t_{d(\text{clkL-dov})}$	Delay time, usb_ulpi_clk rising edge high to output usb_ulpi_d[7:0] valid	0.44	8.35	ns



图 7-51. HS USB3 and USB4 ULPI —SDR—Slave Mode—12-pin Mode

In 表 7-68 are presented the specific groupings of signals (IOSET) for use with USB3 and USB4 signals.

表 7-68. USB3 and USB4 IOSETs

SIGNALS	IOSET1		IOSET2	
	BALL	MUX	BALL	MUX
USB3				
usb3_ulpi_d0	AE1	2	AC3	3
usb3_ulpi_d1	AE5	2	AC9	3
usb3_ulpi_d2	AE3	2	AC6	3
usb3_ulpi_d3	AF1	2	AC7	3
usb3_ulpi_d4	AF4	2	AC4	3
usb3_ulpi_d5	AF3	2	AD4	3
usb3_ulpi_d6	AF6	2	AB4	3
usb3_ulpi_d7	AF2	2	AC5	3
usb3_ulpi_nxt	AE2	2	AC8	3
usb3_ulpi_dir	AE6	2	AD6	3
usb3_ulpi_stp	AD2	2	AB8	3
usb3_ulpi_clk	AD3	2	AB5	3
USB4				
usb4_ulpi_d0			V6	6
usb4_ulpi_d1			U6	6
usb4_ulpi_d2			U5	6
usb4_ulpi_d3			V5	6
usb4_ulpi_d4			V4	6
usb4_ulpi_d5			V3	6
usb4_ulpi_d6			Y2	6
usb4_ulpi_d7			W2	6
usb4_ulpi_stp			V9	6
usb4_ulpi_clk			W9	6
usb4_ulpi_dir			V7	6

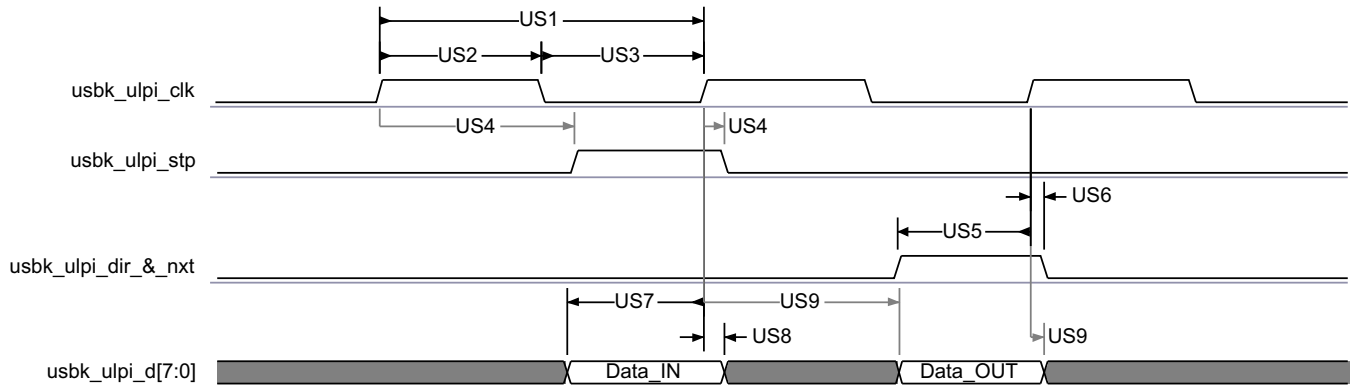
表 7-68. USB3 and USB4 IOSETs (continued)

SIGNALS	IOSET1		IOSET2	
	BALL	MUX	BALL	MUX
usb4_ulpi_nxt			U7	6

7.19 Serial Advanced Technology Attachment (SATA)

The SATA RX/TX PHY interface is compliant with the SATA standard v2.6 for a maximum data rate:

- Gen2i, Gen2m, Gen2x: 3Gbps.
- Gen1i, Gen1m, Gen1x: 1.5Gbps.

注: For more information, see the SATA Controller section of the Device TRM.

7.20 Peripheral Component Interconnect Express (PCIe)

The device supports connections to PCIe-compliant devices via the integrated PCIe master/slave bus interface. The PCIe module is comprised of a dual-mode PCIe core and a SerDes PHY. Each PCIe subsystem controller has support for PCIe Gen-II mode (5.0 Gbps /lane) and Gen-I mode (2.5 Gbps/lane) (Single Lane and Flexible dual lane configuration).

The device PCIe supports the following features:

- 16-bit operation @250 MHz on PIPE interface (per 16-bit lane)
- Supports 2 ports x 1 lane or 1 port x 2 lanes configuration
- Single virtual channel (VC0), single traffic class (TC0)
- Single function in end-point mode
- Automatic width and speed negotiation
- Max payload: 128 byte outbound, 256 byte inbound
- Automatic credit management
- ECRC generation and checking
- Configurable BAR filtering
- Legacy interrupt reception (RC) and generation (EP)
- MSI generation and reception
- PCI Express Active State Power Management (ASPM) state L0s and L1 (with exceptions)
- All PCI Device Power Management D-states with the exception of D3_{cold} / L2 state

The PCIe controller on this device conforms to the PCI Express Base 3.0 Specification, revision 1.0 and the PCI Local Bus Specification, revision 3.0.

注: For more information, see the PCIe Controller section of the Device TRM.

7.21 Controller Area Network Interface (DCAN)

The device provides two DCAN interfaces for supporting distributed realtime control with a high level of security. The DCAN interfaces implement the following features:

- Supports CAN protocol version 2.0 part A, B
- Bit rates up to 1 MBit/s
- 64 message objects
- Individual identifier mask for each message object
- Programmable FIFO mode for message objects
- Programmable loop-back modes for self-test operation

- Suspend mode for debug support
- Software module reset
- Automatic bus on after Bus-Off state by a programmable 32-bit timer
- Direct access to Message RAM during test mode
- CAN Rx/Tx pins are configurable as general-purpose IO pins
- Two interrupt lines (plus additional parity-error interrupts line)
- RAM initialization
- DMA support

注: For more information, see the DCAN section of the Device TRM.

注: The Controller Area Network Interface x (x = 1 to 2) is also referred to as DCANx.

注: Refer to the CAN Specification for calculations necessary to validate timing compliance. Jitter tolerance calculations must be performed to validate the implementation.

表 7-69 和 表 7-70 present timing and switching characteristics for DCANx Interface.

表 7-69. Timing Requirements for DCANx Receive

NO.	PARAMETER	DESCRIPTION	MIN	NOM	MAX	UNIT
-	f(baud)	Maximum programmable baud rate			1	Mbps
-	t _d (DCANRX)	Delay time, DCANx_RX pin to receive shift register			15	ns

表 7-70. Switching Characteristics Over Recommended Operating Conditions for DCANx Transmit

NO.	PARAMETER	DESCRIPTION	MIN	MAX	UNIT
-	f(baud)	Maximum programmable baud rate		1	Mbps
-	t _d (DCANTX)	Delay time, Transmit shift register to DCANx_TX pin ⁽¹⁾		15	ns

(1) These values do not include rise/fall times of the output buffer.

7.22 Ethernet Interface (GMAC_SW)

The three-port gigabit ethernet switch subsystem (GMAC_SW) provides ethernet packet communication and can be configured as an ethernet switch. It provides the Gigabit Media Independent Interface (G/MII) in MII mode, Reduced Gigabit Media Independent Interface (RGMI), Reduced Media Independent Interface (RMII), and the Management Data Input/Output (MDIO) for physical layer device (PHY) management.

注: For more information, see the Ethernet Subsystem section of the Device TRM.

注: The Gigabit, Reduced and Media Independent Interface n (n = 0 to 1) are also referred to as MIIn, RMIIIn and RGMIIIn

注意

The IO timings provided in this section are only valid if signals within a single IOSET are used. The IOSETs are defined in the 表 7-75, 表 7-78, 表 7-83 和 表 7-90.

注意

The IO Timings provided in this section are only valid for some GMAC usage modes when the corresponding Virtual IO Timings or Manual IO Timings are configured as described in the tables found in this section.

表 7-71 和 图 7-52 呈现 timing requirements for MIIn in receive operation.

7.22.1 GMAC MIIn Timings

表 7-71. Timing Requirements for miin_rxclk - MIIn Operation

NO.	PARAMETER	DESCRIPTION	SPEED	MIN	MAX	UNIT
1	$t_{c(RX_CLK)}$	Cycle time, miin_rxclk	10 Mbps	400		ns
			100 Mbps	40		ns
2	$t_{w(RX_CLKH)}$	Pulse duration, miin_rxclk high	10 Mbps	140	260	ns
			100 Mbps	14	26	ns
3	$t_{w(RX_CLKL)}$	Pulse duration, miin_rxclk low	10 Mbps	140	260	ns
			100 Mbps	14	26	ns
4	$t_t(RX_CLK)$	Transition time, miin_rxclk	10 Mbps		3	ns
			100 Mbps		3	ns



图 7-52. Clock Timing (GMAC Receive) - MIIn operation

表 7-72 和 图 7-53 呈现 timing requirements for MIIn in transmit operation.

表 7-72. Timing Requirements for miin_txclk - MIIn Operation

NO.	PARAMETER	DESCRIPTION	SPEED	MIN	MAX	UNIT
1	$t_{c(TX_CLK)}$	Cycle time, miin_txclk	10 Mbps	400		ns
			100 Mbps	40		ns
2	$t_{w(TX_CLKH)}$	Pulse duration, miin_txclk high	10 Mbps	140	260	ns
			100 Mbps	14	26	ns
3	$t_{w(TX_CLKL)}$	Pulse duration, miin_txclk low	10 Mbps	140	260	ns
			100 Mbps	14	26	ns
4	$t_t(TX_CLK)$	Transition time, miin_txclk	10 Mbps		3	ns
			100 Mbps		3	ns

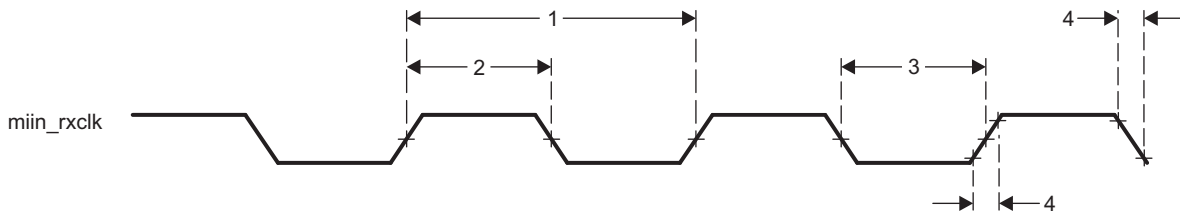

图 7-53. Clock Timing (GMAC Transmit) - MIIn operation

表 7-73 和 图 7-54 present timing requirements for GMAC MII_n Receive 10/100Mbit/s.

表 7-73. Timing Requirements for GMAC MII_n Receive 10/100 Mbit/s

NO.	PARAMETER	DESCRIPTION	MIN	MAX	UNIT
1	$t_{su}(RXD-RX_CLK)$	Setup time, receive selected signals valid before miin_rxclock	8		ns
	$t_{su}(RX_DV-RX_CLK)$				
	$t_{su}(RX_ER-RX_CLK)$				
2	$t_h(RX_CLK-RXD)$	Hold time, receive selected signals valid after miin_rxclock	8		ns
	$t_h(RX_CLK-RX_DV)$				
	$t_h(RX_CLK-RX_ER)$				

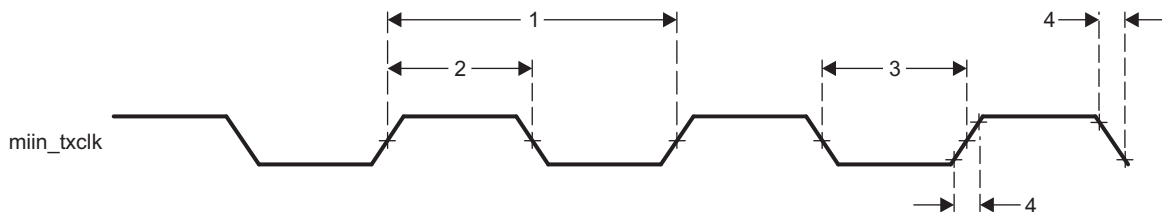

图 7-54. GMAC Receive Interface Timing MII_n operation

表 7-74 和 图 7-55 present timing requirements for GMAC MII_n Transmit 10/100Mbit/s.

表 7-74. Switching Characteristics Over Recommended Operating Conditions for GMAC MII_n Transmit 10/100 Mbits/s

NO.	PARAMETER	DESCRIPTION	MIN	MAX	UNIT
1	$t_d(TX_CLK-TXD)$	Delay time, miin_txclk to transmit selected signals valid	0	25	ns
	$t_d(TX_CLK-TX_EN)$				
	$t_d(TX_CLK-TX_ER)$				

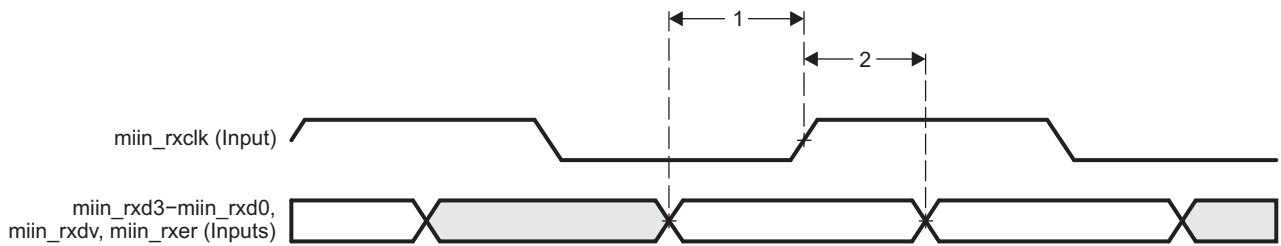

图 7-55. GMAC Transmit Interface Timing MII_n operation

In 表 7-75 are presented the specific groupings of signals (IOSET) for use with GMAC MII signals.

表 7-75. GMAC MII IOSETs

SIGNALS	IOSET5		IOSET6	
	BALL	MUX	BALL	MUX
GMAC MII1				
mii1_txd3	C5	8		
mii1_txd2	D6	8		
mii1_txd1	B2	8		
mii1_txd0	C4	8		
mii1_rxd3	F5	8		
mii1_rxd2	E4	8		
mii1_rxd1	C1	8		

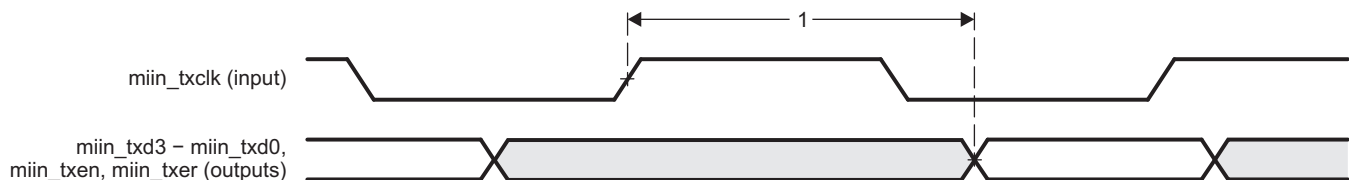
表 7-75. GMAC MII IOSETs (continued)

SIGNALS	IOSET5		IOSET6	
	BALL	MUX	BALL	MUX
mii1_rxd0	E6	8		
mii1_col	B4	8		
mii1_rxer	B3	8		
mii1_txer	A3	8		
mii1_txen	A4	8		
mii1_crs	B5	8		
mii1_rxclk	D5	8		
mii1_txclk	C3	8		
mii1_rxdv	C2	8		
GMAC MII0				
mii0_txd3			V5	3
mii0_txd2			V4	3
mii0_txd1			Y2	3
mii0_txd0			W2	3
mii0_rxd3			W9	3
mii0_rxd2			V9	3
mii0_rxd1			V6	3
mii0_rxd0			U6	3
mii0_txclk			U5	3
mii0_txer			U4	3
mii0_rxer			U7	3
mii0_rxdv			V2	3
mii0_crs			V7	3
mii0_col			V1	3
mii0_rxclk			Y1	3
mii0_txen			V3	3

7.22.2 GMAC MDIO Interface Timings

注意

The IO Timings provided in this section are only valid for some GMAC usage modes when the corresponding Virtual IO Timings or Manual IO Timings are configured as described in the tables found in this section.

表 7-76, 表 7-76 and 図 7-56 present timing requirements for MDIO.

表 7-76. Timing Requirements for MDIO Input

No	PARAMETER	DESCRIPTION	MIN	MAX	UNIT
MDIO1	$t_{c(MDC)}$	Cycle time, MDC	400		ns
MDIO2	$t_{w(MDCH)}$	Pulse Duration, MDC High	160		ns
MDIO3	$t_{w(MDCL)}$	Pulse Duration, MDC Low	160		ns
MDIO4	$t_{su(MDIO-MDC)}$	Setup time, MDIO valid before MDC High	90		ns
MDIO5	$t_{h(MDIO_MDC)}$	Hold time, MDIO valid from MDC High	0		ns

表 7-77. Switching Characteristics Over Recommended Operating Conditions for MDIO Output

NO	PARAMETER	DESCRIPTION	MIN	MAX	UNIT
MDIO6	$t_{t(MDC)}$	Transition time, MDC		5	ns
MDIO7	$t_{d(MDC-MDIO)}$	Delay time, MDC low to MDIO valid	-150	150	ns



图 7-56. GMAC MDIO diagrams

In 表 7-78 are presented the specific groupings of signals (IOSET) for use with GMAC MDIO signals.

表 7-78. GMAC MDIO IOSETs

SIGNALS	IOSET7		IOSET8		IOSET9		IOSET10	
	BALL	MUX	BALL	MUX	BALL	MUX	BALL	MUX
mdio_d	F6	3	U4	0	AB4	1	B20	5
mdio_mclk	D3	3	V1	0	AC5	1	B21	5

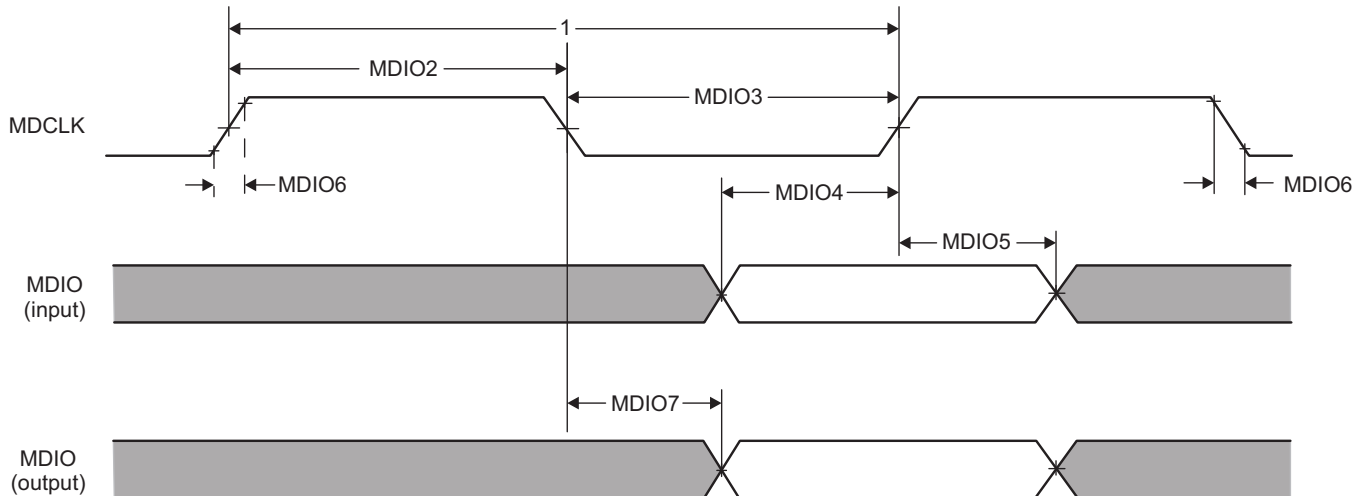
7.2.2.3 GMAC RMII Timings

The main reference clock REF_CLK (RMII_50MHZ_CLK) of RMII interface is internally supplied from PRCM. The source of this clock could be either externally sourced from the RMII_MHZ_50_CLK pin of the device or internally generated from DPLL_GMAC output clock GMAC_RMII_HS_CLK. Please see the PRCM chapter of the device TRM for full details about RMII reference clock.

注意

The IO Timings provided in this section are only valid for some GMAC usage modes when the corresponding Virtual IO Timings or Manual IO Timings are configured as described in the tables found in this section.

表 7-79, 表 7-80 and 图 7-57 present timing requirements for GMAC RMII Receive.

表 7-79. Timing Requirements for GMAC REF_CLK - RMII Operation

NO.	PARAMETER	DESCRIPTION	MIN	MAX	UNIT
RMII1	$t_{c(REF_CLK)}$	Cycle time, REF_CLK	20		ns
RMII2	$t_{w(REF_CLKH)}$	Pulse duration, REF_CLK high	7	13	ns
RMII3	$t_{w(REF_CLKL)}$	Pulse duration, REF_CLK low	7	13	ns
RMII4	$t_{t(REF_CLK)}$	Transition time, REF_CLK		3	ns

表 7-80. Timing Requirements for GMAC RMII_n Receive

NO.	PARAMETER	DESCRIPTION	MIN	MAX	UNIT
RMII5	$t_{su}(RXD-REF_CLK)$	Setup time, receive selected signals valid before REF_CLK	4		ns
	$t_{su}(CRS_DV-REF_CLK)$				
	$t_{su}(RX_ER-REF_CLK)$				
RMII6	$t_h(REF_CLK-RXD)$	Hold time, receive selected signals valid after REF_CLK	2		ns
	$t_h(REF_CLK-CRS_DV)$				
	$t_h(REF_CLK-RX_ER)$				

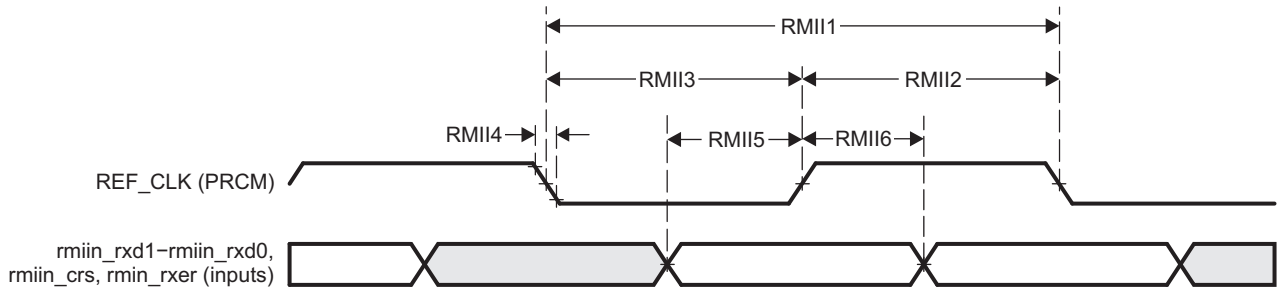

SPRS8xx_GMAC_RMII RX_05

图 7-57. GMAC Receive Interface Timing RMII_n operation

表 7-81, 表 7-81 and 图 7-58 present switching characteristics for GMAC RMII_n Transmit 10/100Mbit/s.

表 7-81. Switching Characteristics Over Recommended Operating Conditions for GMAC REF_CLK - RMII Operation

NO.	PARAMETER	DESCRIPTION	MIN	MAX	UNIT
RMII7	$t_c(REF_CLK)$	Cycle time, REF_CLK	20		ns
RMII8	$t_w(REF_CLKH)$	Pulse duration, REF_CLK high	7	13	ns
RMII9	$t_w(REF_CLKL)$	Pulse duration, REF_CLK low	7	13	ns
RMII10	$t_t(REF_CLK)$	Transistion time, REF_CLK		3	ns

表 7-82. Switching Characteristics Over Recommended Operating Conditions for GMAC RMII_n Transmit 10/100 Mbits/s

NO.	PARAMETER	DESCRIPTION	RMII _n	MIN	MAX	UNIT
RMII11	$t_d(REF_CLK-TXD)$	Delay time, REF_CLK high to selected transmit signals valid	RMII0	2	13.5	ns
	$t_d(REF_CLK-TXEN)$					
	$t_d(REF_CLK-TXD)$		RMII1	2	13.8	ns
	$t_d(REF_CLK-TXEN)$					

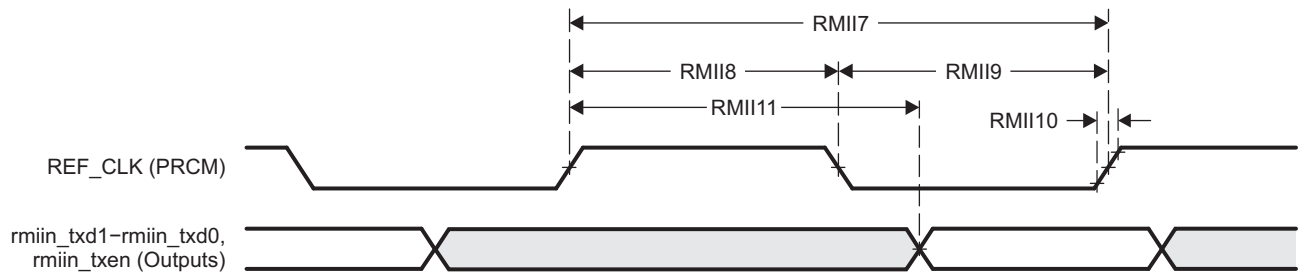

SPRS8xx_GMAC_RMII TX_06

图 7-58. GMAC Transmit Interface Timing RMII_n Operation

In 表 7-83 are presented the specific groupings of signals (IOSET) for use with GMAC RMII signals.

表 7-83. GMAC RMII IOSETs

SIGNALS	IOSET1		IOSET2	
	BALL	MUX	BALL	MUX
GMAC RMII1				
RMII_MHZ_50_CLK	U3	0		
rmii1_txd1	V5	2		
rmii1_txd0	V4	2		
rmii1_rxd1	W9	2		
rmii1_rxd0	V9	2		
rmii1_rxer	Y1	2		
rmii1_txen	U5	2		
rmii1_crs	V2	2		
GMAC RMII0				
RMII_MHZ_50_CLK			U3	0
rmii0_txd1			Y2	1
rmii0_txd0			W2	1
rmii0_rxd1			V6	1
rmii0_rxd0			U6	1
rmii0_txen			V3	1
rmii0_rxer			U7	1
rmii0_crs			V7	1

Manual IO Timings Modes must be used to ensure some IO timings for GMAC. See [表 7-2 Modes Summary](#) for a list of IO timings requiring the use of Manual IO Timings Modes. See [表 7-84 Manual Functions Mapping for GMAC RMII0](#) for a definition of the Manual modes.

[表 7-84](#) lists the A_DELAY and G_DELAY values needed to calculate the correct values to be set in the CFG_x registers.

表 7-84. Manual Functions Mapping for GMAC RMII0

BALL	BALL NAME	GMAC_RMII0_MANUAL1		CFG REGISTER	MUXMODE	
		A_DELAY (ps)	G_DELAY (ps)		0	1
U3	RMII_MHZ_50_CLK	0	0	CFG_RMII_MHZ_50_CLK_IN	RMII_MHZ_50_CLK	
U6	rgmii0_txd0	500	500	CFG_RGMII0_TXD0_IN		rmii0_rxd0
V6	rgmii0_txd1	840	1000	CFG_RGMII0_TXD1_IN		rmii0_rxd1
U7	rgmii0_txd2	360	840	CFG_RGMII0_TXD2_IN		rmii0_rxer
V7	rgmii0_txd3	600	1000	CFG_RGMII0_TXD3_IN		rmii0_crs

Manual IO Timings Modes must be used to ensure some IO timings for GMAC. See [表 7-2 Modes Summary](#) for a list of IO timings requiring the use of Manual IO Timings Modes. See [表 7-85 Manual Functions Mapping for GMAC RMII1](#) for a definition of the Manual modes.

[表 7-85](#) list the A_DELAY and G_DELAY values needed to calculate the correct values to be set in the CFG_x registers.

表 7-85. Manual Functions Mapping for GMAC RMII1

BALL	BALL NAME	GMAC_RMII1_MANUAL1		CFG REGISTER	MUXMODE	
		A_DELAY (ps)	G_DELAY (ps)		0	2
U3	RMII_MHZ_50_CLK	0	0	CFG_RMII_MHZ_50_CLK_IN	RMII_MHZ_50_CLK	
V9	rgmii0_txctl	300	1000	CFG_RGMII0_TXCTL_IN		rmii1_rxd0

表 7-85. Manual Functions Mapping for GMAC RMII1 (continued)

BALL	BALL NAME	GMAC_RMII1_MANUAL1		CFG REGISTER	MUXMODE	
		A_DELAY (ps)	G_DELAY (ps)		0	2
W9	rgmii0_txc	300	1200	CFG_RGMII0_TXC_IN		rmii1_rxd1
Y1	uart3_txd	300	500	CFG_UART3_TXD_IN		rmii1_rxer
V2	uart3_rxd	400	700	CFG_UART3_RXD_IN		rmii1_crs

7.22.4 GMAC RGMII Timings

注意

The IO Timings provided in this section are only valid for some GMAC usage modes when the corresponding Virtual IO Timings or Manual IO Timings are configured as described in the tables found in this section.

表 7-86, 表 7-87 和 图 7-59 present timing requirements for receive RGMII operation.

表 7-86. Timing Requirements for rgmiin_rxc - RGMII Operation

NO.	PARAMETER	DESCRIPTION	SPEED	MIN	MAX	UNIT
1	$t_{c(RXC)}$	Cycle time, rgmiin_rxc	10 Mbps	360	440	ns
			100 Mbps	36	44	ns
			1000 Mbps	7.2	8.8	ns
2	$t_{w(RXCH)}$	Pulse duration, rgmiin_rxc high	10 Mbps	160	240	ns
			100 Mbps	16	24	ns
			1000 Mbps	3.6	4.4	ns
3	$t_{w(RXCL)}$	Pulse duration, rgmiin_rxc low	10 Mbps	160	240	ns
			100 Mbps	16	24	ns
			1000 Mbps	3.6	4.4	ns
4	$t_{t(RXC)}$	Transition time, rgmiin_rxc	10 Mbps		0.75	ns
			100 Mbps		0.75	ns
			1000 Mbps		0.75	ns

表 7-87. Timing Requirements for GMAC RGMII Input Receive for 10/100/1000 Mbps

NO.	PARAMETER	DESCRIPTION	MIN	MAX	UNIT
5	$t_{su(RXD-RXCH)}$	Setup time, receive selected signals valid before rgmiin_rxc high/low	1		ns
6	$t_{h(RXCH-RXD)}$	Hold time, receive selected signals valid after rgmiin_rxc high/low	1		ns

(1) For RGMII, receive selected signals include: rgmiin_rxd[3:0] and rgmiin_rxctl.

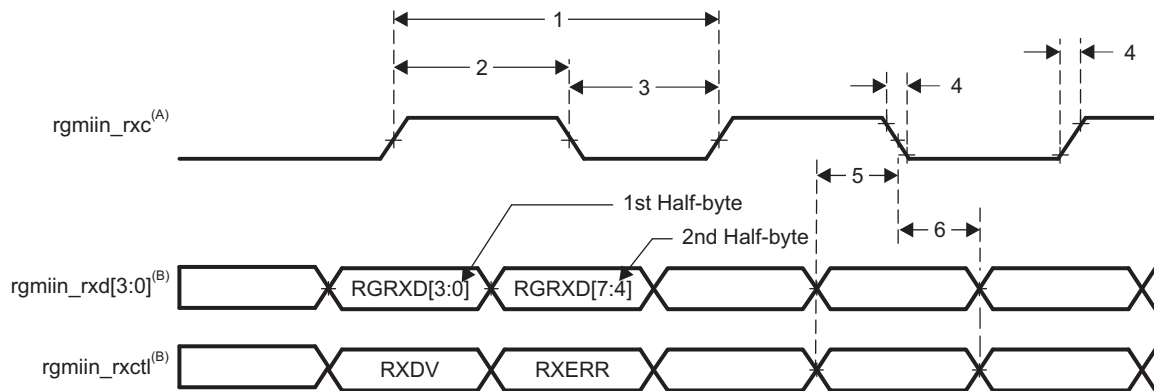

- A. rgmiin_rxc must be externally delayed relative to the data and control pins.
B. Data and control information is received using both edges of the clocks. rgmiin_rxd[3:0] carries data bits 3-0 on the rising edge of rgmiin_rxc and data bits 7-4 on the falling edge of rgmiin_rxc. Similarly, rgmiin_rxctl carries RXDV on rising edge of rgmiin_rxc and RXERR on falling edge of rgmiin_rxc.

图 7-59. GMAC Receive Interface Timing, RGMII operation

表 7-88, 表 7-89 和 图 7-60 呈现 switching characteristics for transmit - RGMII for 10/100/1000Mbit/s.

表 7-88. Switching Characteristics Over Recommended Operating Conditions for rgmiin_txctl - RGMII Operation for 10/100/1000 Mbit/s

NO.	PARAMETER	DESCRIPTION	SPEED	MIN	MAX	UNIT
1	$t_{c(TXC)}$	Cycle time, rgmiin_txc	10 Mbps	360	440	ns
			100 Mbps	36	44	ns
			1000 Mbps	7.2	8.8	ns
2	$t_{w(TXCH)}$	Pulse duration, rgmiin_txc high	10 Mbps	160	240	ns
			100 Mbps	16	24	ns
			1000 Mbps	3.6	4.4	ns
3	$t_{w(TXCL)}$	Pulse duration, rgmiin_txc low	10 Mbps	160	240	ns
			100 Mbps	16	24	ns
			1000 Mbps	3.6	4.4	ns
4	$t_{t(TXC)}$	Transition time, rgmiin_txc	10 Mbps		0.75	ns
			100 Mbps		0.75	ns
			1000 Mbps		0.75	ns

表 7-89. Switching Characteristics for GMAC RGMII Output Transmit for 10/100/1000 Mbps (1)

NO.	PARAMETER	DESCRIPTION	MODE	MIN	MAX	UNIT
5	$t_{osu(TXD-TXC)}$	Output Setup time, transmit selected signals valid to rgmiin_txc high/low	RGMII0, Internal Delay Enabled, 1000 Mbps	1.05 (2)		ns
			RGMII0, Internal Delay Enabled, 10/100 Mbps	1.2		ns
			RGMII1, Internal Delay Enabled, 1000 Mbps	1.05 (3)		ns
			RGMII1, Internal Delay Enabled, 10/100 Mbps	1.2		ns

表 7-89. Switching Characteristics for GMAC RGMII Output Transmit for 10/100/1000 Mbps ⁽¹⁾ (continued)

NO.	PARAMETER	DESCRIPTION	MODE	MIN	MAX	UNIT
6	t _{oh} (TxC-TxD)	Output Hold time, transmit selected signals valid after rgmiiin_txc high/low	RGMIIO, Internal Delay Enabled, 1000 Mbps	1.05 ⁽²⁾		ns
			RGMIIO, Internal Delay Enabled, 10/100 Mbps	1.2		ns
			RGMI11, Internal Delay Enabled, 1000 Mbps	1.05 ⁽³⁾		ns
			RGMI11, Internal Delay Enabled, 10/100 Mbps	1.2		ns

- (1) For RGMII, transmit selected signals include: rgmiiin_txd[3:0] and rgmiiin_txctl.
- (2) RGMIIO 1000Mbps operation requires that the 4 data pins rgmii0_txd[3:0] and rgmii0_txctl have their board propagation delays matched within 50pS of rgmii0_txc
- (3) RGMI11 1000Mbps operation requires that the 4 data pins rgmii1_txd[3:0] and rgmii1_txctl have their board propagation delays matched within 50pS of rgmii1_txc.

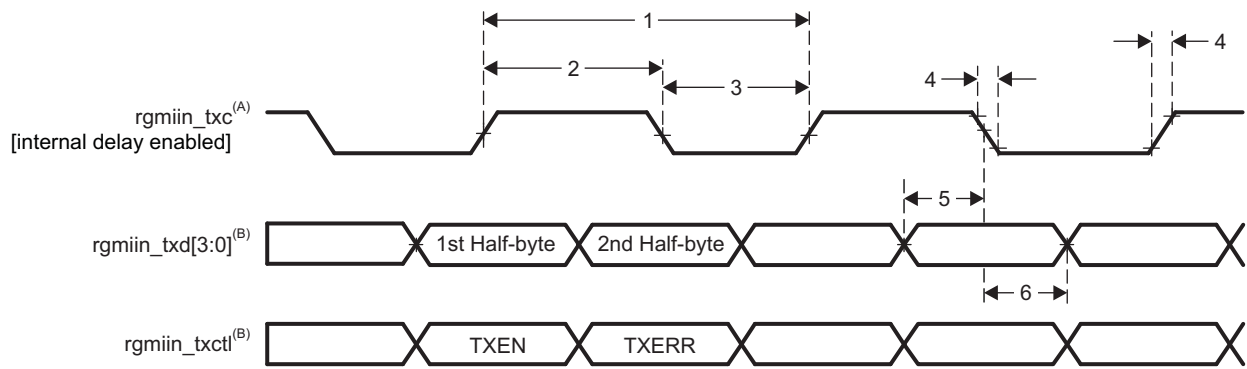

- A. TxC is delayed internally before being driven to the rgmiiin_txc pin. This internal delay is always enabled.
- B. Data and control information is transmitted using both edges of the clocks. rgmiiin_txd[3:0] carries data bits 3-0 on the rising edge of rgmiiin_txc and data bits 7-4 on the falling edge of rgmiiin_txc. Similarly, rgmiiin_txctl carries TXEN on rising edge of rgmiiin_txc and TXERR on falling edge of rgmiiin_txc.

图 7-60. GMAC Transmit Interface Timing RGMII operation

In 表 7-90 are presented the specific groupings of signals (IOSET) for use with GMAC RGMII signals.

表 7-90. GMAC RGMII IOSETs

SIGNALS	IOSET3		IOSET4	
	BALL	MUX	BALL	MUX
GMAC RGMII1				
rgmii1_txd3	C3	3		
rgmii1_txd2	C4	3		
rgmii1_txd1	B2	3		
rgmii1_txd0	D6	3		
rgmii1_rxd3	B3	3		
rgmii1_rxd2	B4	3		
rgmii1_rxd1	B5	3		
rgmii1_rxd0	A4	3		
rgmii1_rxctl	A3	3		
rgmii1_txc	D5	3		
rgmii1_txctl	C2	3		
rgmii1_rxc	C5	3		
GMAC RGMII0				
rgmii0_txd3			V7	0

表 7-90. GMAC RGMII IOSETs (continued)

SIGNALS	IOSET3		IOSET4	
	BALL	MUX	BALL	MUX
rgmii0_txd2			U7	0
rgmii0_txd1			V6	0
rgmii0_txd0			U6	0
rgmii0_rxd3			V4	0
rgmii0_rxd2			V3	0
rgmii0_rxd1			Y2	0
rgmii0_rxd0			W2	0
rgmii0_txc			W9	0
rgmii0_rxctl			V5	0
rgmii0_rxc			U5	0
rgmii0_txctl			V9	0

注: To configure the desired Manual IO Timing Mode the user must follow the steps described in section "Manual IO Timing Modes" of the Device TRM.

The associated registers to configure are listed in the **CFG REGISTER** column. For more information please see the *Control Module Chapter* in the Device TRM.

Manual IO Timings Modes must be used to ensure some IO timings for GMAC. See [表 7-2 Modes Summary](#) for a list of IO timings requiring the use of Manual IO Timings Modes. See [表 7-91 Manual Functions Mapping for GMAC RGMII0](#) for a definition of the Manual modes.

[表 7-92](#) lists the A_DELAY and G_DELAY values needed to calculate the correct values to be set in the CFG_x registers.

表 7-91. Manual Functions Mapping for GMAC RGMII0

BALL	BALL NAME	GMAC_RGMII0_MANUAL1		CFG REGISTER	MUXMODE
		A_DELAY (ps)	G_DELAY (ps)		0
U5	rgmii0_rxc	260	0	CFG_RGMII0_RXC_IN	rgmii0_rxc
V5	rgmii0_rxctl	0	1412	CFG_RGMII0_RXCTL_IN	rgmii0_rxctl
W2	rgmii0_rxd0	123	1047	CFG_RGMII0_RXD0_IN	rgmii0_rxd0
Y2	rgmii0_rxd1	139	1081	CFG_RGMII0_RXD1_IN	rgmii0_rxd1
V3	rgmii0_rxd2	195	1100	CFG_RGMII0_RXD2_IN	rgmii0_rxd2
V4	rgmii0_rxd3	239	1216	CFG_RGMII0_RXD3_IN	rgmii0_rxd3
W9	rgmii0_txc	89	0	CFG_RGMII0_TXC_OUT	rgmii0_txc
V9	rgmii0_txctl	15	125	CFG_RGMII0_TXCTL_OUT	rgmii0_txctl
U6	rgmii0_txd0	339	162	CFG_RGMII0_TXD0_OUT	rgmii0_txd0
V6	rgmii0_txd1	146	94	CFG_RGMII0_TXD1_OUT	rgmii0_txd1
U7	rgmii0_txd2	0	27	CFG_RGMII0_TXD2_OUT	rgmii0_txd2
V7	rgmii0_txd3	291	205	CFG_RGMII0_TXD3_OUT	rgmii0_txd3

Manual IO Timings Modes must be used to ensure some IO timings for GMAC. See [表 7-2 Modes Summary](#) for a list of IO timings requiring the use of Manual IO Timings Modes. See [表 7-92 Manual Functions Mapping for GMAC RGMII1](#) for a definition of the Manual modes.

[表 7-92](#) lists the A_DELAY and G_DELAY values needed to calculate the correct values to be set in the CFG_x registers.

表 7-92. Manual Functions Mapping for GMAC RGMII1

BALL	BALL NAME	GMAC_RGMII1_MANUAL1		CFG REGISTER	MUXMODE
		A_DELAY (ps)	G_DELAY (ps)		3
C5	vin2a_d18	411	0	CFG_VIN2A_D18_IN	rgmii1_rxc
A3	vin2a_d19	0	382	CFG_VIN2A_D19_IN	rgmii1_rxctl
B3	vin2a_d20	320	750	CFG_VIN2A_D20_IN	rgmii1_rxd3
B4	vin2a_d21	192	836	CFG_VIN2A_D21_IN	rgmii1_rxd2
B5	vin2a_d22	294	669	CFG_VIN2A_D22_IN	rgmii1_rxd1
A4	vin2a_d23	50	700	CFG_VIN2A_D23_IN	rgmii1_rxd0
D5	vin2a_d12	0	0	CFG_VIN2A_D12_OUT	rgmii1_txc
C2	vin2a_d13	219	101	CFG_VIN2A_D13_OUT	rgmii1_txctl
C3	vin2a_d14	92	58	CFG_VIN2A_D14_OUT	rgmii1_txd3
C4	vin2a_d15	135	100	CFG_VIN2A_D15_OUT	rgmii1_txd2
B2	vin2a_d16	154	101	CFG_VIN2A_D16_OUT	rgmii1_txd1
D6	vin2a_d17	78	27	CFG_VIN2A_D17_OUT	rgmii1_txd0

7.23 Media Local Bus (MLB) interface

The MLBSS allows connection to a MOST (Media Oriented Systems Transport) network controller for transport of media and control data between multimedia nodes. The MLBSS supports the following features:

- 3 pin mode compliant to MediaLB Physical Layer Specification v4.0
- 6 pin mode (3 differential pairs) compliant to MediaLB Physical Layer Specification v4.0
- Supports 256/512/1024Fs in 3 pin mode and 2048Fs in 6 pin mode
- Supports all types of transfer (Sync, Isoc, Async/Packet, Control) over 64 logical channels
- 16KB buffering for synchronous /isochronous/control/packet data in the subsystem

注: For more information, see the Media Local Bus (MLB) section of the Device TRM.

注: MLB in 6-pin mode may require pullups/ pulldowns on SIG and DAT bus signals. For additional details, please consult the MLB bus interface specification.

表 7-93 and 图 7-61 present Timing Requirements for MLBCLK 3-Pin Option.

表 7-93. Timing Requirements for MLBCLK 3-Pin Option

NO.	PARAMETER	DESCRIPTION	MODE	MIN	MAX	UNIT
1	$t_{c(MLBCLK)}$	Cycle time, MLB_CLK	512FS	39		ns
			1024FS	19.5		ns
2	$t_{w(MLBCLK)}$	Pulse duration, MLB_CLK high	512FS	14		ns
			1024FS	9.3		ns
3	$t_{w(MLBCLK)}$	Pulse duration, MLB_CLK low	512FS	14		ns
			1024FS	6.1		ns



图 7-61. MLB_CLK Timing

表 7-94 和 表 7-95 present Timing Requirements and Switching Characteristics for MLB 3-Pin Option.

表 7-94. Timing Requirements for Receive Data for the MLB 3-Pin Option

NO.	PARAMETER	DESCRIPTION	MODE	MIN	MAX	UNIT
5	$t_{su}(MLBDAT-MLBCLKL)$	Setup time, MLB_DAT/MLB_SIG input valid before MLB_CLK low	512FS	1		ns
			1024FS	1		ns
6	$t_h(MLBCLKL-MLBDAT)$	Hold time, MLB_DAT/MLB_SIG input valid after MLB_CLK low	512FS	4		ns
			1024FS	2		ns

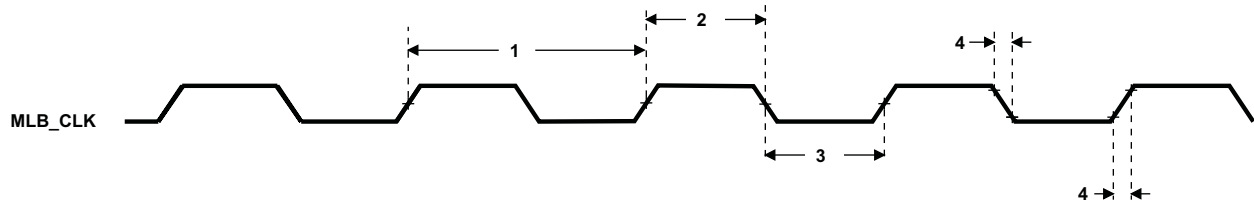
表 7-95. Switching Characteristics Over Recommended Operating Conditions for MLB 3-Pin Option

NO.	PARAMETER	DESCRIPTION	MODE	MIN	MAX	UNIT
7	$t_d(MLBCLKH-MLBDATV)$	Delay time, MLBCLKH rising to MLB_DAT/MLB_SIG valid	512FS	0	10	ns
			1024FS	0	7	ns
8	$t_{dis}(MLBCLKL-MLBDATZ)$	Disable time, MLBCLKH falling to MLB_DAT/MLB_SIG Hi-Z	512FS	0	14	ns
			1024FS	0	6.1	ns

表 7-96 和 图 7-61 present Timing Requirements for MLKCLK 6-Pin Option.

表 7-96. Timing Requirements for MLBCLK 6-Pin Option

NO.	PARAMETER	DESCRIPTION	MODE	MIN	MAX	UNIT
1	$t_c(MLBCLKx)$	Cycle time, MLB_CLKP/N	2048FS	10		ns
2	$t_w(MLBCLKx)$	Pulse duration, MLB_CLKP/N high	2048FS	4.5		ns
3	$t_w(MLBCLKx)$	Pulse duration, MLB_CLKP/N low	2048FS	4.5		ns

表 7-97 和 表 7-98 present Timing Requirements and Switching Characteristics for MLB 6-Pin Option.

表 7-97. Timing Requirements for Receive Data for the MLB 6-Pin Option ⁽¹⁾

NO.	PARAMETER	DESCRIPTION	MODE	MIN	MAX	UNIT
5	$t_{su}(DATx-CLKxH)$	Setup time, MLBP_DATx/MLBP_SIGx input valid before MLBP_CLKx rising	2048FS	1		ns
6	$t_h(CLKxH-DATx)$	Hold time, MLBP_DATx/MLBP_SIGx input valid after MLBP_CLKx rising	2048FS	0.5		ns

(1) MLBP_SIGx/MLBP_DATx is valid at the receiver input for at least TBD.

表 7-98. Switching Characteristics Over Recommended Operating Conditions for MLB 6-Pin Option ⁽¹⁾

NO.	PARAMETER	DESCRIPTION	MODE	MIN	MAX	UNIT
7	$t_d(CLKxH-DATxV)$	Delay time, MLBPCLKxH rising to MLBP_DATx/MLBP_SIGx valid	2048FS	0.5	7	ns
8	$t_{dis}(CLKPH-DATPZ)$	Disable time, MLBPCLKxH rising to MLBP_DATx/MLBP_SIGx Hi-Z	2048FS	0.5	7	ns

(1) MLBP_SIGx/MLBP_DATx is valid at the receiver input for at least TBD.

注: To configure the desired Manual IO Timing Mode the user must follow the steps described in section "Manual IO Timing Modes" of the Device TRM.

The associated registers to configure are listed in the **CFG REGISTER** column. For more information please see the *Control Module Chapter* in the Device TRM.

Manual IO Timings Modes must be used to ensure some IO timings for MLB. See 表 7-2 Modes Summary for a list of IO timings requiring the use of Manual IO Timings Modes. See 表 7-99 Manual Functions Mapping for MLB for a definition of the Manual modes.

表 7-99 lists the A_DELAY and G_DELAY values needed to calculate the correct values to be set in the CFG_x registers.

表 7-99. Manual Functions Mapping for MLB

BALL	BALL NAME	MLB_MANUAL 1		CFG REGISTER	MUXMODE	
		A_DELAY (ps)	G_DELAY (ps)		0	5
AA3	mcasp5_aclkx	175	0	CFG_MCASP5_ACLKX_IN	-	mlb_clk
AA3	mcasp5_aclkx	430	411	CFG_MCASP5_ACLKX_OUT	-	mlb_clk
AB3	mcasp5_axr0	0	0	CFG_MCASP5_AXR0_IN	-	mlb_sig
AB3	mcasp5_axr0	0	0	CFG_MCASP5_AXR0_OEN	-	mlb_sig
AB3	mcasp5_axr0	0	0	CFG_MCASP5_AXR0_OUT	-	mlb_sig
AA4	mcasp5_axr1	0	0	CFG_MCASP5_AXR1_IN	-	mlb_dat
AA4	mcasp5_axr1	0	0	CFG_MCASP5_AXR1_OEN	-	mlb_dat
AA4	mcasp5_axr1	0	0	CFG_MCASP5_AXR1_OUT	-	mlb_dat
AB1	mlbp_clk_p	0	0	CFG_MLBP_CLK_P_IN	mlbp_clk_p	-
AB1	mlbp_clk_p	321	43	CFG_MLBP_CLK_P_OUT	mlbp_clk_p	-
AA2	mlbp_dat_n	30	1170	CFG_MLBP_DAT_N_IN	mlbp_dat_n	-
AA2	mlbp_dat_n	0	0	CFG_MLBP_DAT_N_OEN	mlbp_dat_n	-
AA2	mlbp_dat_n	0	0	CFG_MLBP_DAT_N_OUT	mlbp_dat_n	-
AA1	mlbp_dat_p	30	1170	CFG_MLBP_DAT_P_IN	mlbp_dat_p	-
AA1	mlbp_dat_p	0	0	CFG_MLBP_DAT_P_OEN	mlbp_dat_p	-
AA1	mlbp_dat_p	0	0	CFG_MLBP_DAT_P_OUT	mlbp_dat_p	-
AC2	mlbp_sig_n	55	1223	CFG_MLBP_SIG_N_IN	mlbp_sig_n	-
AC2	mlbp_sig_n	0	0	CFG_MLBP_SIG_N_OEN	mlbp_sig_n	-
AC2	mlbp_sig_n	0	0	CFG_MLBP_SIG_N_OUT	mlbp_sig_n	-
AC1	mlbp_sig_p	55	1223	CFG_MLBP_SIG_P_IN	mlbp_sig_p	-
AC1	mlbp_sig_p	0	0	CFG_MLBP_SIG_P_OEN	mlbp_sig_p	-
AC1	mlbp_sig_p	0	0	CFG_MLBP_SIG_P_OUT	mlbp_sig_p	-

7.24 eMMC/SD/SDIO

The Device includes the following external memory interfaces 4 MultiMedia Card/Secure Digital/Secure Digital Input Output Interface (MMC/SD/SDIO).

注: The eMMC/SD/SDIO_i (i = 1 to 4) controller is also referred to as MMC_i.

7.24.1 MMC1—SD Card Interface

MMC1 interface is compliant with the SD Standard v3.01 and it supports the following SD Card applications:

- Default speed, 4-bit data, SDR, half-cycle
- High speed, 4-bit data, SDR, half-cycle
- SDR12, 4-bit data, half-cycle
- SDR25, 4-bit data, half-cycle
- UHS-I SDR50, 4-bit data, half-cycle
- UHS-I SDR104, 4-bit data, half-cycle
- UHS-I DDR50, 4-bit data

注: For more information, see the eMMC/SD/SDIO chapter of the Device TRM.

7.24.1.1 Default speed, 4-bit data, SDR, half-cycle

表 7-100 和 表 7-101 呈现 Timing requirements and Switching characteristics for MMC1 - Default Speed in receiver and transmitter mode (see 图 7-62 和 图 7-63)

表 7-100. Timing Requirements for MMC1 - SD Card Default Speed Mode

NO.	PARAMETER	DESCRIPTION	MIN	MAX	UNIT
DSSD5	$t_{su}(cmdV-clkH)$	Setup time, mmc1_cmd valid before mmc1_clk rising clock edge	5.11		ns
DSSD6	$t_{h}(clkH-cmdV)$	Hold time, mmc1_cmd valid after mmc1_clk rising clock edge	20.46		ns
DSSD7	$t_{su}(dV-clkH)$	Setup time, mmc1_dat[3:0] valid before mmc1_clk rising clock edge	5.11		ns
DSSD8	$t_{h}(clkH-dV)$	Hold time, mmc1_dat[3:0] valid after mmc1_clk rising clock edge	20.46		ns

表 7-101. Switching Characteristics for MMC1 - SD Card Default Speed Mode

NO.	PARAMETER	DESCRIPTION	MIN	MAX	UNIT
DSSD0	fop(clk)	Operating frequency, mmc1_clk		24	MHz
DSSD1	$t_w(\text{clkH})$	Pulse duration, mmc1_clk high	0.5*P-0.185(1)		ns
DSSD2	$t_w(\text{clkL})$	Pulse duration, mmc1_clk low	0.5*P-0.185(1)		ns
DSSD3	$t_d(\text{clkL-cmdV})$	Delay time, mmc1_clk falling clock edge to mmc1_cmd transition	-14.93	14.93	ns
DSSD4	$t_d(\text{clkL-dV})$	Delay time, mmc1_clk falling clock edge to mmc1_dat[3:0] transition	-14.93	14.93	ns

(1) P = output mmc1_clk period in ns



图 7-62. MMC/SD/SDIO in - Default Speed - Receiver Mode



图 7-63. MMC/SD/SDIO in - Default Speed - Transmitter Mode

7.24.1.2 High speed, 4-bit data, SDR, half-cycle

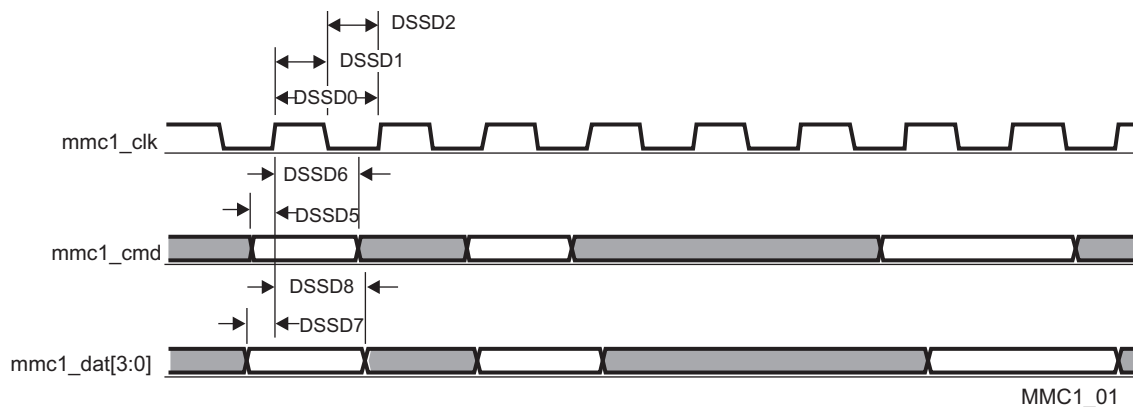
表 7-102 和 表 7-103 呈现 Timing requirements 和 Switching characteristics for MMC1 - High Speed in receiver and transmitter mode (see 图 7-64 和 图 7-65)

表 7-102. Timing Requirements for MMC1 - SD Card High Speed Mode

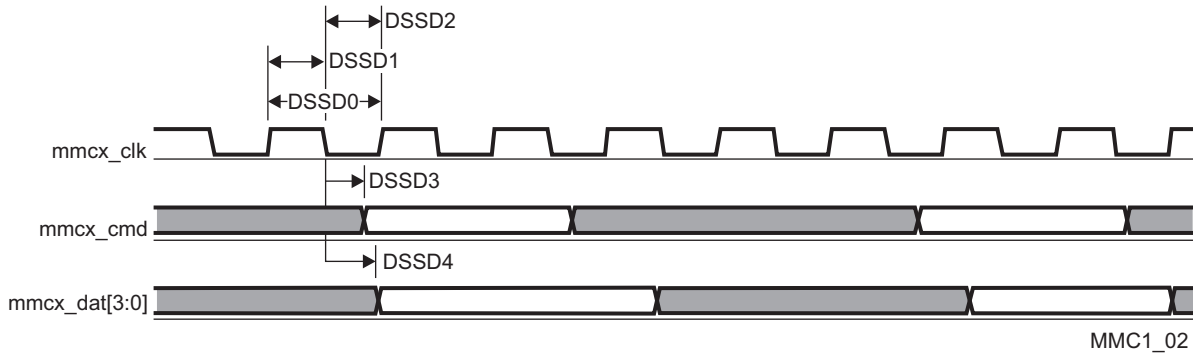
NO.	PARAMETER	DESCRIPTION	MIN	MAX	UNIT
HSSD3	$t_{su}(cmdV-clkH)$	Setup time, mmc1_cmd valid before mmc1_clk rising clock edge	5.3		ns
HSSD4	$t_h(clkH-cmdV)$	Hold time, mmc1_cmd valid after mmc1_clk rising clock edge	2.6		ns
HSSD7	$t_{su}(dV-clkH)$	Setup time, mmc1_dat[3:0] valid before mmc1_clk rising clock edge	5.3		ns
HSSD8	$t_h(clkH-dV)$	Hold time, mmc1_dat[3:0] valid after mmc1_clk rising clock edge	2.6		ns

表 7-103. Switching Characteristics for MMC1 - SD Card High Speed Mode

NO.	PARAMETER	DESCRIPTION	MIN	MAX	UNIT
HSSD1	fop(clk)	Operating frequency, mmc1_clk		48	MHz
HSSD2H	$t_w(clkH)$	Pulse duration, mmc1_clk high	0.5*P-0.185 (1)		ns
HSSD2L	$t_w(clkL)$	Pulse duration, mmc1_clk low	0.5*P-0.185 (1)		ns
HSSD5	$t_d(clkL-cmdV)$	Delay time, mmc1_clk falling clock edge to mmc1_cmd transition	-7.6	3.6	ns
HSSD6	$t_d(clkL-dV)$	Delay time, mmc1_clk falling clock edge to mmc1_dat[3:0] transition	-7.6	3.6	ns

(1) P = output mmc1_clk period in ns



图 7-64. MMC/SD/SDIO in - High Speed - Receiver Mode



图 7-65. MMC/SD/SDIO in - High Speed - Transmitter Mode

7.24.1.3 SDR12, 4-bit data, half-cycle

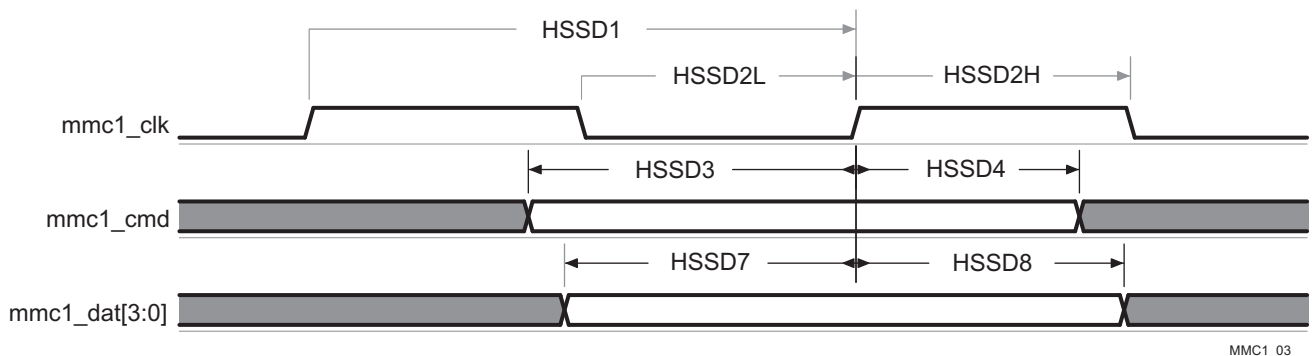
表 7-104 和 表 7-105 呈现 Timing requirements and Switching characteristics for MMC1 - SDR12 in receiver and transmitter mode(see 图 7-66 和 图 7-67).

表 7-104. Timing Requirements for MMC1 - SD Card SDR12 Mode

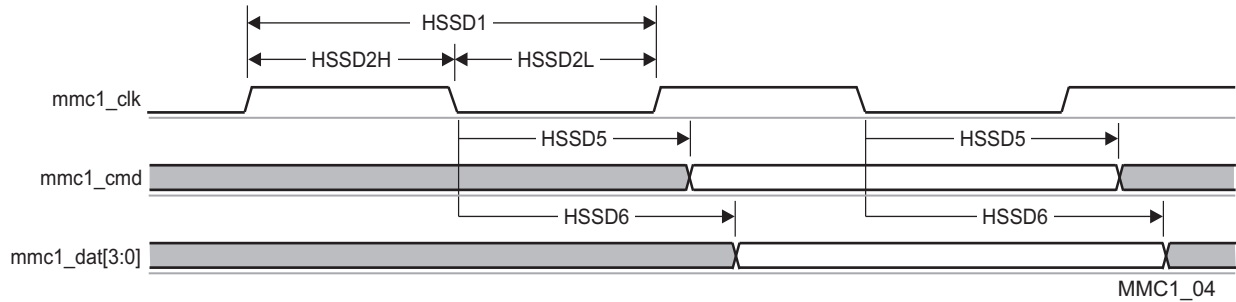
NO.	PARAMETER	DESCRIPTION	MODE	MIN	MAX	UNIT
SDR12 5	$t_{su}(cmdV-clkH)$	Setup time, mmc1_cmd valid before mmc1_clk rising clock edge		25.99		ns
SDR12 6	$t_h(clkH-cmdV)$	Hold time, mmc1_cmd valid after mmc1_clk rising clock edge	Pad Loopback Clock	1.6		ns
			Internal Loopback Clock	1.6		ns
SDR12 7	$t_{su}(dV-clkH)$	Setup time, mmc1_dat[3:0] valid before mmc1_clk rising clock edge		25.99		ns
SDR12 8	$t_h(clkH-dV)$	Hold time, mmc1_dat[3:0] valid after mmc1_clk rising clock edge	Pad Loopback Clock	1.6		ns
			Internal Loopback Clock	1.6		ns

表 7-105. Switching Characteristics for MMC1 - SD Card SDR12 Mode

NO.	PARAMETER	DESCRIPTION	MIN	MAX	UNIT
SDR120	fop(clk)	Operating frequency, mmc1_clk		24	MHz
SDR121	$t_w(clkH)$	Pulse duration, mmc1_clk high	0.5*P- 0.185 (1)		ns
SDR122	$t_w(clkL)$	Pulse duration, mmc1_clk low	0.5*P- 0.185 (1)		ns
SDR123	$t_d(clkL-cmdV)$	Delay time, mmc1_clk falling clock edge to mmc1_cmd transition	-19.13	16.93	ns
SDR124	$t_d(clkL-dV)$	Delay time, mmc1_clk falling clock edge to mmc1_dat[3:0] transition	-19.13	16.93	ns

(1) P = output mmc1_clk period in ns



图 7-66. MMC/SD/SDIO in - High Speed SDR12 - Receiver Mode



图 7-67. MMC/SD/SDIO in - High Speed SDR12 - Transmitter Mode

7.24.1.4 SDR25, 4-bit data, half-cycle

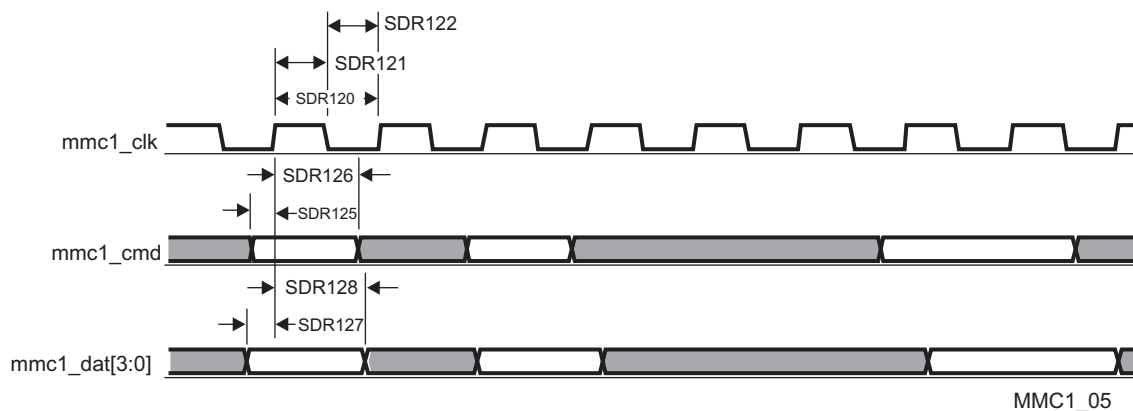
表 7-106 和 表 7-107 呈现 Timing requirements and Switching characteristics for MMC1 - SDR25 in receiver and transmitter mode (see 图 7-68 和 图 7-69).

表 7-106. Timing Requirements for MMC1 - SD Card SDR25 Mode

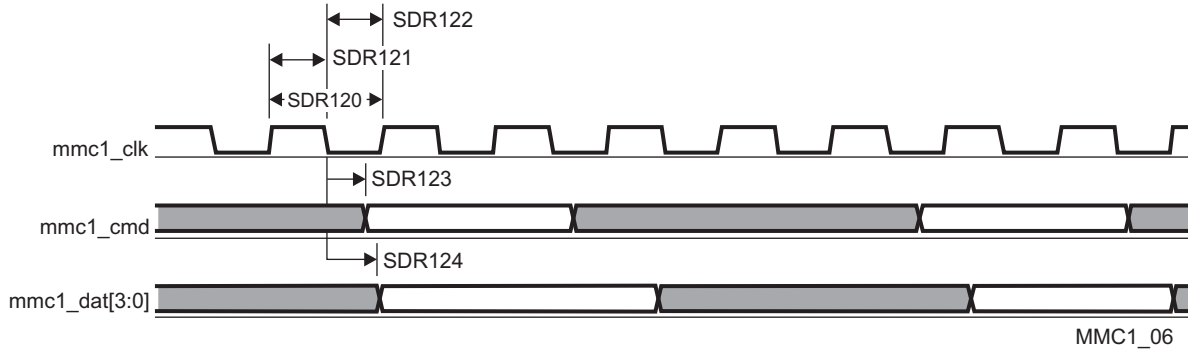
NO.	PARAMETER	DESCRIPTION	MODE	MIN	MAX	UNIT
SDR25 3	$t_{su}(cmdV-clkH)$	Setup time, mmc1_cmd valid before mmc1_clk rising clock edge		5.3		ns
SDR25 4	$t_h(clkH-cmdV)$	Hold time, mmc1_cmd valid after mmc1_clk rising clock edge		1.6		ns
SDR25 7	$t_{su}(dV-clkH)$	Setup time, mmc1_dat[3:0] valid before mmc1_clk rising clock edge		5.3		ns
SDR25 8	$t_h(clkH-dV)$	Hold time, mmc1_dat[3:0] valid after mmc1_clk rising clock edge	Pad Loopback Clock	1.6		ns
			Internal Loopback Clock	1.6		ns

表 7-107. Switching Characteristics for MMC1 - SD Card SDR25 Mode

NO.	PARAMETER	DESCRIPTION	MIN	MAX	UNIT
SDR251	fop(clk)	Operating frequency, mmc1_clk		48	MHz
SDR252 H	$t_w(clkH)$	Pulse duration, mmc1_clk high	0.5*P- 0.185 (1)		ns
SDR252L	$t_w(clkL)$	Pulse duration, mmc1_clk low	0.5*P- 0.185 (1)		ns
SDR255	$t_d(clkL-cmdV)$	Delay time, mmc1_clk falling clock edge to mmc1_cmd transition	-8.8	6.6	ns
SDR256	$t_d(clkL-dV)$	Delay time, mmc1_clk falling clock edge to mmc1_dat[3:0] transition	-8.8	6.6	ns

(1) P = output mmc1_clk period in ns



图 7-68. MMC/SD/SDIO in - High Speed SDR25 - Receiver Mode



图 7-69. MMC/SD/SDIO in - High Speed SDR25 - Transmitter Mode

7.24.1.5 UHS-I SDR50, 4-bit data, half-cycle

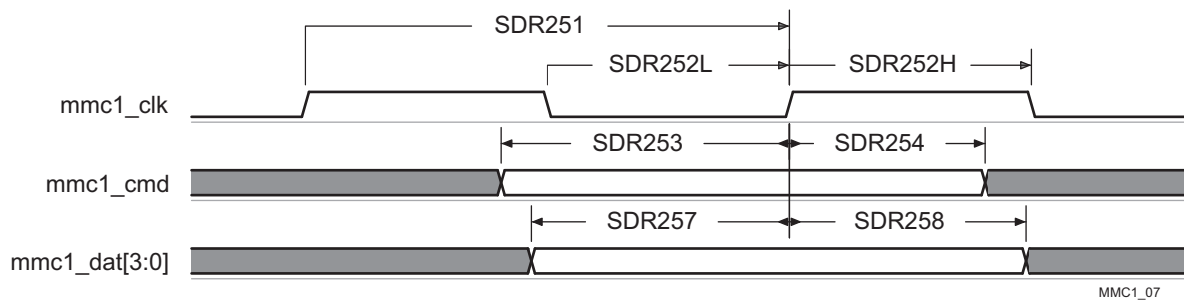
表 7-108 和 表 7-109 呈现 Timing requirements 和 Switching characteristics for MMC1 - SDR50 in receiver and transmitter mode (see 图 7-70 和 图 7-71).

表 7-108. Timing Requirements for MMC1 - SD Card SDR50 Mode

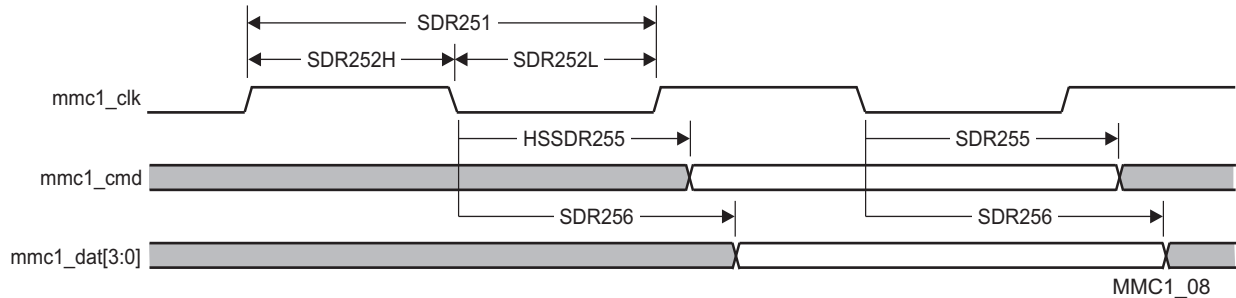
NO.	PARAMETER	DESCRIPTION	MODE	MIN	MAX	UNIT
SDR50 3	$t_{su(cmdV-clkH)}$	Setup time, mmc1_cmd valid before mmc1_clk rising clock edge		1.72		ns
SDR50 4	$t_{h(clkH-cmdV)}$	Hold time, mmc1_cmd valid after mmc1_clk rising clock edge		1.6		ns
SDR50 7	$t_{su(dV-clkH)}$	Setup time, mmc1_dat[3:0] valid before mmc1_clk rising clock edge		1.72		ns
SDR50 8	$t_{h(clkH-dV)}$	Hold time, mmc1_dat[3:0] valid after mmc1_clk rising clock edge	Pad Loopback Clock	1.6		ns
			Internal Loopback Clock	1.6		ns

表 7-109. Switching Characteristics for MMC1 - SD Card SDR50 Mode

NO.	PARAMETER	DESCRIPTION	MIN	MAX	UNIT
SDR501	fop(clk)	Operating frequency, mmc1_clk		96	MHz
SDR502 H	$t_{w(clkH)}$	Pulse duration, mmc1_clk high	0.5*P- 0.185 (1)		ns
SDR502L	$t_{w(clkL)}$	Pulse duration, mmc1_clk low	0.5*P- 0.185 (1)		ns
SDR505	$t_{d(clkL-cmdV)}$	Delay time, mmc1_clk falling clock edge to mmc1_cmd transition	-3.66	1.46	ns
SDR506	$t_{d(clkL-dV)}$	Delay time, mmc1_clk falling clock edge to mmc1_dat[3:0] transition	-3.66	1.46	ns

(1) P = output mmc1_clk period in ns



图 7-70. MMC/SD/SDIO in - High Speed SDR50 - Receiver Mode



图 7-71. MMC/SD/SDIO in - High Speed SDR50 - Transmitter Mode

7.24.1.6 UHS-I SDR104, 4-bit data, half-cycle

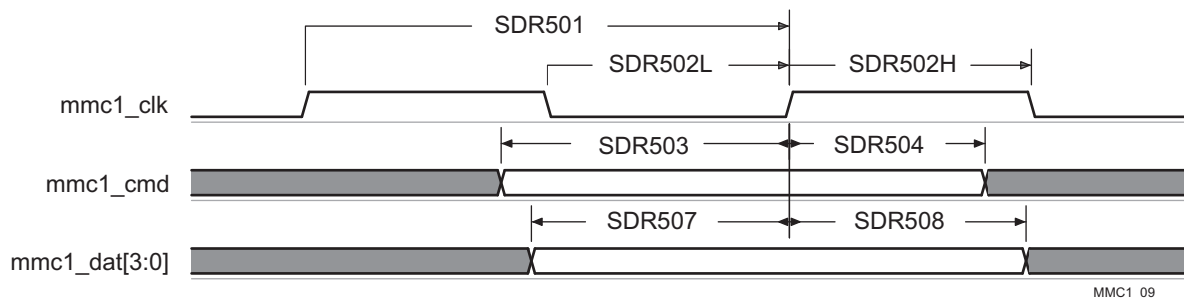
表 7-110 presents Timing requirements and Switching characteristics for MMC1 - SDR104 in receiver and transmitter mode (see 图 7-72 and 图 7-73)

表 7-110. Switching Characteristics for MMC1 - SD Card SDR104 Mode

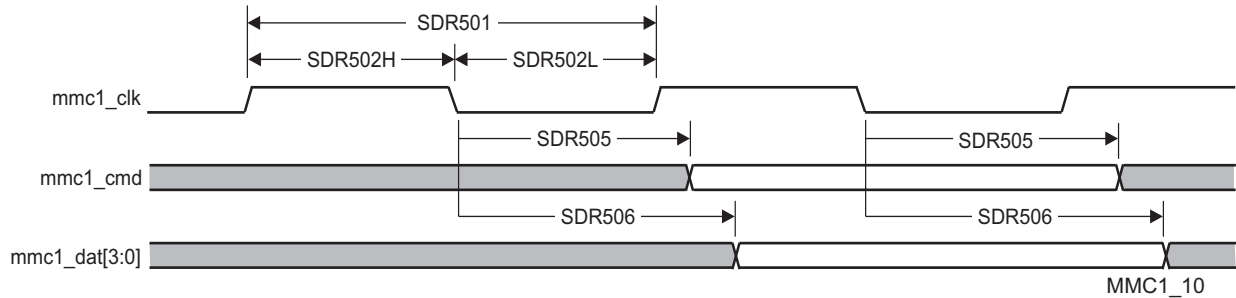
NO.	PARAMETER	DESCRIPTION	MIN	MAX	UNIT
SDR1041	fop(clk)	Operating frequency, mmc1_clk		192	MHz
SDR1042 H	t _w (clkH)	Pulse duration, mmc1_clk high	0.5*P- 0.185 (1)		ns
SDR1042 L	t _w (clkL)	Pulse duration, mmc1_clk low	0.5*P- 0.185 (1)		ns
SDR1045	t _d (clkL-cmdV)	Delay time, mmc1_clk falling clock edge to mmc1_cmd transition	-1.09	0.49	ns
SDR1046	t _d (clkL-dV)	Delay time, mmc1_clk falling clock edge to mmc1_dat[3:0] transition	-1.09	0.49	ns

(1) P = output mmc1_clk period in ns



图 7-72. MMC/SD/SDIO in - High Speed SDR104 - Receiver Mode



图 7-73. MMC/SD/SDIO in - High Speed SDR104 - Transmitter Mode

7.24.1.7 UHS-I DDR50, 4-bit data

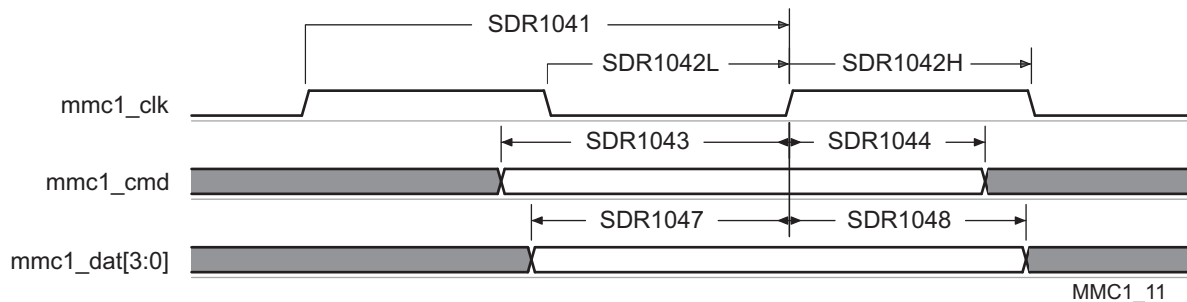
表 7-111 and 表 7-112 present Timing requirements and Switching characteristics for MMC1 - DDR50 in receiver and transmitter mode (see 图 7-74 and 图 7-75).

表 7-111. Timing Requirements for MMC1 - SD Card DDR50 Mode

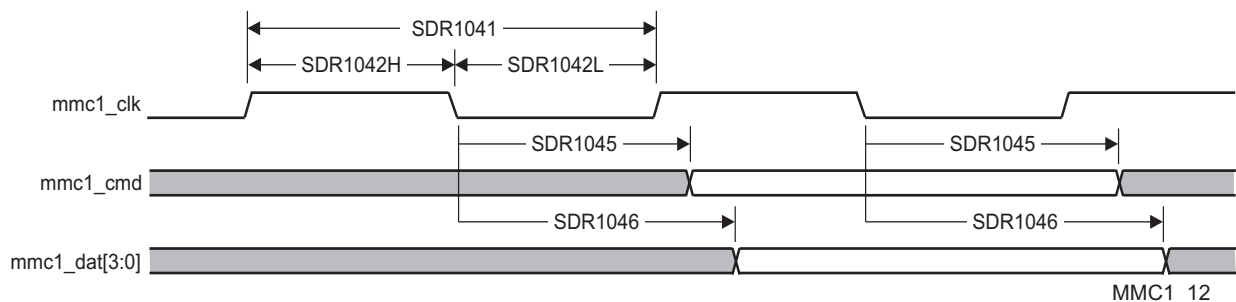
NO.	PARAMETER	DESCRIPTION	MODE	MIN	MAX	UNIT
DDR505	$t_{su(cmdV-clk)}$	Setup time, mmc1_cmd valid before mmc1_clk transition		1.79		ns
DDR506	$t_{h(clk-cmdV)}$	Hold time, mmc1_cmd valid after mmc1_clk transition		1.6		ns
DDR507	$t_{su(dV-clk)}$	Setup time, mmc1_dat[3:0] valid before mmc1_clk transition	Pad Loopback	1.79		ns
			Internal Loopback	1.79		ns
DDR508	$t_{h(clk-dV)}$	Hold time, mmc1_dat[3:0] valid after mmc1_clk transition	Pad Loopback	1.6		ns
			Internal Loopback	1.6		ns

表 7-112. Switching Characteristics for MMC1 - SD Card DDR50 Mode

NO.	PARAMETER	DESCRIPTION	MIN	MAX	UNIT
DDR500	fop(clk)	Operating frequency, mmc1_clk		48	MHz
DDR501	$t_{w(clkH)}$	Pulse duration, mmc1_clk high	0.5*P-0.185 (1)		ns
DDR502	$t_{w(clkL)}$	Pulse duration, mmc1_clk low	0.5*P-0.185 (1)		ns
DDR503	$t_{d(clk-cmdV)}$	Delay time, mmc1_clk transition to mmc1_cmd transition	1.225	6.6	
DDR504	$t_{d(clk-dV)}$	Delay time, mmc1_clk transition to mmc1_dat[3:0] transition	1.225	6.6	ns

(1) P = output mmc1_clk period in ns



图 7-74. SDMMC - High Speed SD - DDR - Data/Command Receive



图 7-75. SDMMC - High Speed SD - DDR - Data/Command Transmit

注: To configure the desired virtual mode the user must set MODESELECT bit and DELAYMODE bitfield for each corresponding pad control register.

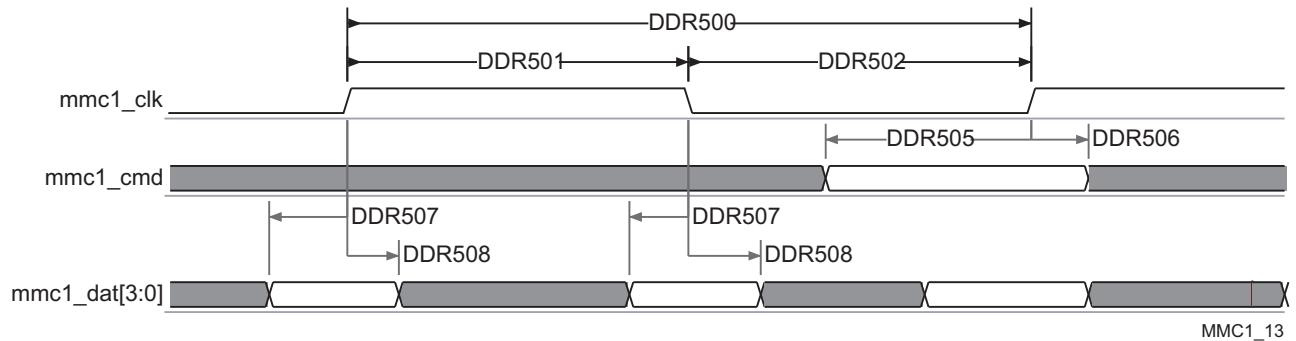
The pad control registers are presented in [表 4-3](#) and described in Device TRM, *Control Module Chapter*.

Virtual IO Timings Modes must be used to ensure some IO timings for MMC1. See [表 7-2 Modes Summary](#) for a list of IO timings requiring the use of Virtual IO Timings Modes. See [表 7-113 Virtual Functions Mapping for MMC1](#) for a definition of the Virtual modes.

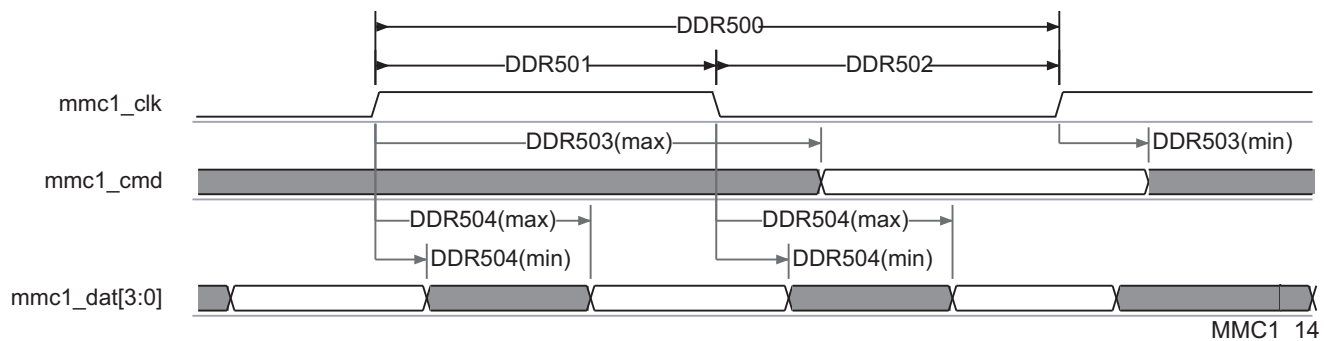
[表 7-113](#) presents the values for DELAYMODE bitfield.

表 7-113. Virtual Functions Mapping for MMC1

BALL	BALL NAME	Delay Mode Value					MUXMODE[15:0]
		MMC1_VIRTUA L1	MMC1_VIRTU AL2	MMC1_VIRTUA L5	MMC1_VIRTUA L6	MMC1_VIRTUA L7	0
W6	mmc1_clk	11	10	7	6	5	mmc1_clk
Y6	mmc1_cmd	11	10	7	6	5	mmc1_cmd
AA6	mmc1_dat0	11	10	7	6	5	mmc1_dat0
Y4	mmc1_dat1	11	10	7	6	5	mmc1_dat1
AA5	mmc1_dat2	11	10	7	6	5	mmc1_dat2
Y3	mmc1_dat3	11	10	7	6	5	mmc1_dat3

注: To configure the desired Manual IO Timing Mode the user must follow the steps described in section Manual IO Timing Modes of the Device TRM.

The associated registers to configure are listed in the **CFG REGISTER** column. For more information see the Control Module chapter in the Device TRM.

Manual IO Timings Modes must be used to ensure some IO timings for MMC1. See [表 7-2 Modes Summary](#) for a list of IO timings requiring the use of Manual IO Timings Modes. See [表 7-114 Manual Functions Mapping for MMC1](#) for a definition of the Manual modes.

[表 7-114](#) lists the A_DELAY and G_DELAY values needed to calculate the correct values to be set in the CFG_x registers.

表 7-114. Manual Functions Mapping for MMC1

BALL	BALL NAME	MMC1_DDR_MANUAL1		MMC1_SDR104_MANUAL1		CFG REGISTER	MUXMODE
		A_DELAY (ps)	G_DELAY (ps)	A_DELAY (ps)	G_DELAY (ps)		0
W6	mmc1_clk	1076	330	-	-	CFG_MMC1_CLK_IN	mmc1_clk
W6	mmc1_clk	1271	0	600	400	CFG_MMC1_CLK_OUT	mmc1_clk
Y6	mmc1_cmd	722	0	-	-	CFG_MMC1_CMD_IN	mmc1_cmd
Y6	mmc1_cmd	0	0	0	0	CFG_MMC1_CMD_OEN	mmc1_cmd
Y6	mmc1_cmd	0	0	0	0	CFG_MMC1_CMD_OUT	mmc1_cmd
AA6	mmc1_dat0	751	0	-	-	CFG_MMC1_DAT0_IN	mmc1_dat0
AA6	mmc1_dat0	0	0	0	0	CFG_MMC1_DAT0_OEN	mmc1_dat0
AA6	mmc1_dat0	20	0	30	0	CFG_MMC1_DAT0_OUT	mmc1_dat0
Y4	mmc1_dat1	256	0	-	-	CFG_MMC1_DAT1_IN	mmc1_dat1
Y4	mmc1_dat1	0	0	0	0	CFG_MMC1_DAT1_OEN	mmc1_dat1
Y4	mmc1_dat1	0	0	0	0	CFG_MMC1_DAT1_OUT	mmc1_dat1
AA5	mmc1_dat2	263	0	-	-	CFG_MMC1_DAT2_IN	mmc1_dat2
AA5	mmc1_dat2	0	0	0	0	CFG_MMC1_DAT2_OEN	mmc1_dat2
AA5	mmc1_dat2	0	0	0	0	CFG_MMC1_DAT2_OUT	mmc1_dat2
Y3	mmc1_dat3	0	0	-	-	CFG_MMC1_DAT3_IN	mmc1_dat3
Y3	mmc1_dat3	0	0	0	0	CFG_MMC1_DAT3_OEN	mmc1_dat3
Y3	mmc1_dat3	0	0	0	0	CFG_MMC1_DAT3_OUT	mmc1_dat3

7.24.2 MMC2 — eMMC

MMC2 interface is compliant with the JC64 eMMC Standard v4.5 and it supports the following eMMC applications:

- Standard JC64 SDR, 8-bit data, half cycle
- High-speed JC64 SDR, 8-bit data, half cycle
- High-speed JC64 DDR, 8-bit data
- High-speed HS200 JC64 SDR, 8-bit data, half cycle

注: For more information, see the eMMC/SD/SDIO chapter of the Device TRM.

7.24.2.1 Standard JC64 SDR, 8-bit data, half cycle

表 7-115 和 表 7-116 呈现 Timing requirements 和 Switching characteristics for MMC2 - Standard SDR in receiver and Transmitter mode (see 图 7-76 和 图 7-77).

表 7-115. Timing Requirements for MMC2 - JC64 Standard SDR Mode

NO.	PARAMETER	DESCRIPTION	MIN	MAX	UNIT
SSDR5	$t_{su(cmdV-clkH)}$	Setup time, mmc2_cmd valid before mmc2_clk rising clock edge	13.19		ns
SSDR6	$t_{h(clkH-cmdV)}$	Hold time, mmc2_cmd valid after mmc2_clk rising clock edge	8.4		ns
SSDR7	$t_{su(dV-clkH)}$	Setup time, mmc2_dat[7:0] valid before mmc2_clk rising clock edge	13.19		ns
SSDR8	$t_{h(clkH-dV)}$	Hold time, mmc2_dat[7:0] valid after mmc2_clk rising clock edge	8.4		ns

表 7-116. Switching Characteristics for MMC2 - JC64 Standard SDR Mode

NO.	PARAMETER	DESCRIPTION	MIN	MAX	UNIT
SSDR1	$f_{op}(clk)$	Operating frequency, mmc2_clk		24	MHz
SSDR2H	$t_w(clkH)$	Pulse duration, mmc2_clk high	0.5*P-0.172 (1)		ns
SSDR2L	$t_w(clkL)$	Pulse duration, mmc2_clk low	0.5*P-0.172 (1)		ns
SSDR3	$t_d(clkL-cmdV)$	Delay time, mmc2_clk falling clock edge to mmc2_cmd transition	-16.96	16.96	ns
SSDR4	$t_d(clkL-dV)$	Delay time, mmc2_clk falling clock edge to mmc2_dat[7:0] transition	-16.96	16.96	ns

(1) P = output mmc2_clk period in ns



图 7-76. MMC/SD/SDIO in - Standard JC64 - Receiver Mode



图 7-77. MMC/SD/SDIO in - Standard JC64 - Transmitter Mode

7.24.2.2 High-speed JC64 SDR, 8-bit data, half cycle

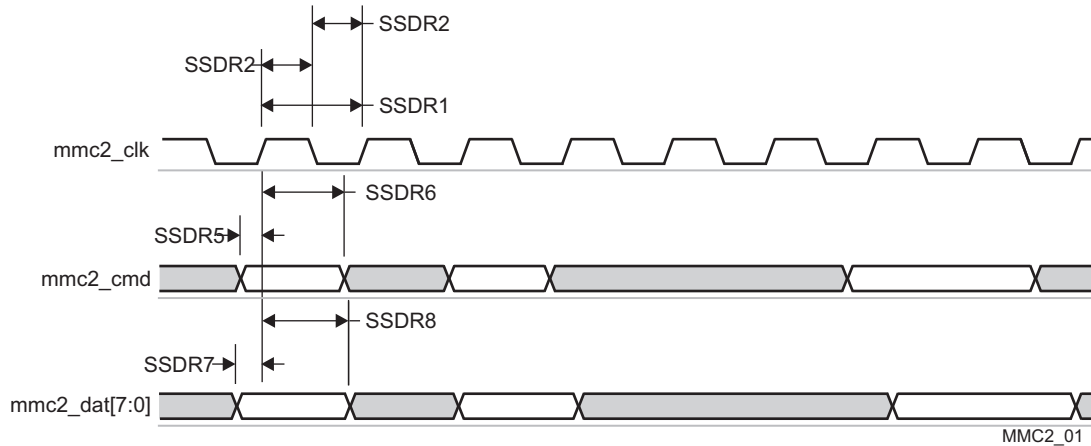
表 7-117 和 表 7-118 呈现 Timing requirements and Switching characteristics for MMC2 - High speed SDR in receiver and transmitter mode (see 图 7-78 和 图 7-79).

表 7-117. Timing Requirements for MMC2 - JC64 High Speed SDR Mode

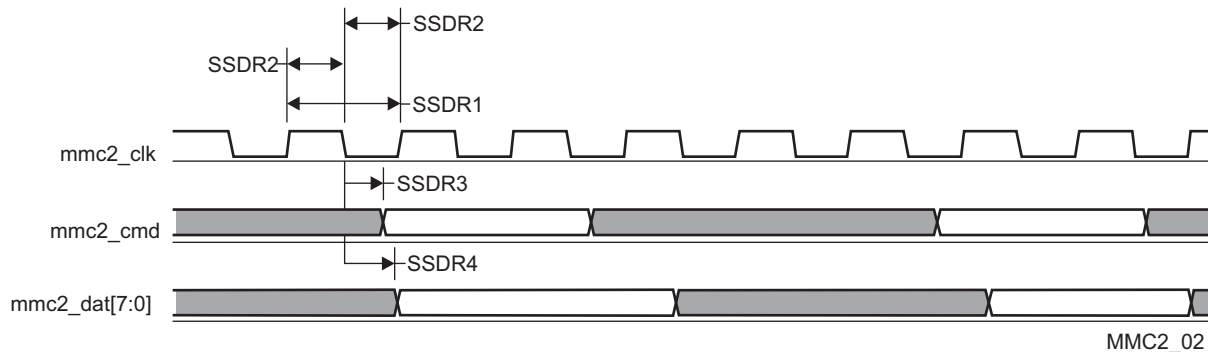
NO.	PARAMETER	DESCRIPTION	MIN	MAX	UNIT
JC643	$t_{su}(cmdV-clkH)$	Setup time, mmc2_cmd valid before mmc2_clk rising clock edge	5.6		ns
JC644	$t_h(clkH-cmdV)$	Hold time, mmc2_cmd valid after mmc2_clk rising clock edge	2.6		ns
JC647	$t_{su}(dV-clkH)$	Setup time, mmc2_dat[7:0] valid before mmc2_clk rising clock edge	5.6		ns
JC648	$t_h(clkH-dV)$	Hold time, mmc2_dat[7:0] valid after mmc2_clk rising clock edge	2.6		ns

表 7-118. Switching Characteristics for MMC2 - JC64 High Speed SDR Mode

NO.	PARAMETER	DESCRIPTION	MIN	MAX	UNIT
JC641	$f_{op}(clk)$	Operating frequency, mmc2_clk		48	MHz
JC642H	$t_w(clkH)$	Pulse duration, mmc2_clk high	0.5*P-0.172 (1)		ns
JC642L	$t_w(clkL)$	Pulse duration, mmc2_clk low	0.5*P-0.172 (1)		ns
JC645	$t_d(clkL-cmdV)$	Delay time, mmc2_clk falling clock edge to mmc2_cmd transition	-6.64	6.64	ns
JC646	$t_d(clkL-dV)$	Delay time, mmc2_clk falling clock edge to mmc2_dat[7:0] transition	-6.64	6.64	ns

(1) P = output mmc2_clk period in ns

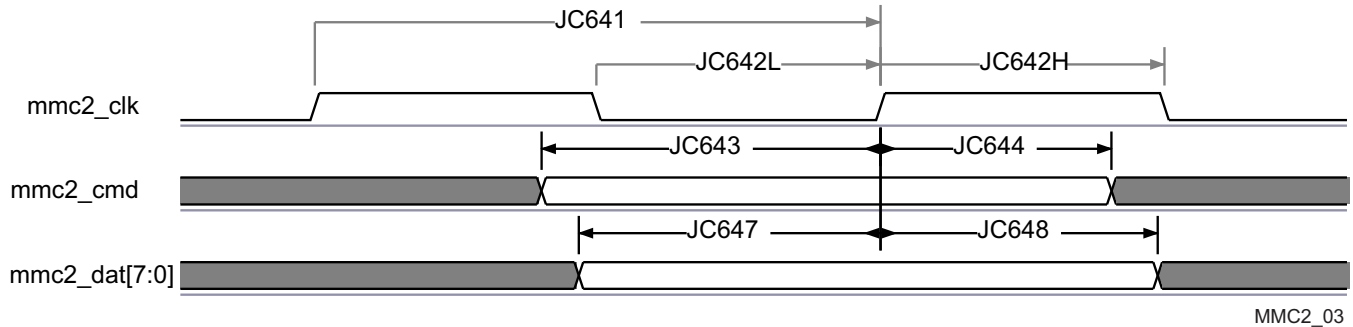

MMC2_03

图 7-78. MMC/SD/SDIO in - High Speed JC64 - Receiver Mode

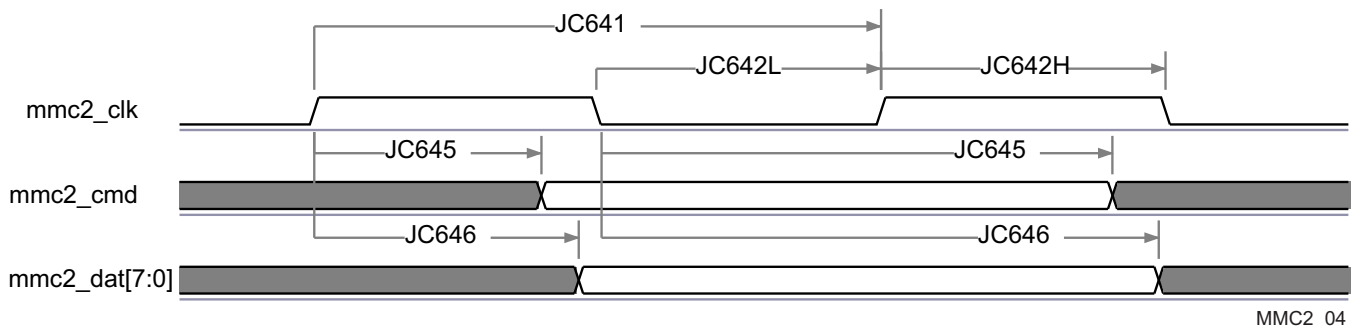

MMC2_04

图 7-79. MMC/SD/SDIO in - High Speed JC64 - Transmitter Mode

7.24.2.3 High-speed HS200 JC64 SDR, 8-bit data, half cycle

表 7-119 presents Timing requirements and Switching characteristics for MMC2 - HS200 in receiver and transmitter mode (see 图 7-80).

表 7-119. Switching Characteristics for MMC2 - JEDS84 HS200 Mode

NO.	PARAMETER	DESCRIPTION	MIN	MAX	UNIT
HS2001	$f_{op}(clk)$	Operating frequency, mmc2_clk		192	MHz
HS2002H	$t_w(clkH)$	Pulse duration, mmc2_clk high	0.5*P-0.172 (1)		ns
HS2002L	$t_w(clkL)$	Pulse duration, mmc2_clk low	0.5*P-0.172 (1)		ns
HS2005	$t_d(clkL-cmdV)$	Delay time, mmc2_clk falling clock edge to mmc2_cmd transition	-1.136	0.536	ns
HS2006	$t_d(clkL-dV)$	Delay time, mmc2_clk falling clock edge to mmc2_dat[7:0] transition	-1.136	0.536	ns

(1) P = output mmc2_clk period in ns



图 7-80. eMMC in - HS200 SDR - Transmitter Mode

7.24.2.4 High-speed JC64 DDR, 8-bit data

表 7-120 和 表 7-121 呈现 Timing requirements and Switching characteristics for MMC2 - High speed DDR in receiver and transmitter mode (see 图 7-81 和 图 7-82).

表 7-120. Timing Requirements for MMC2 - JC64 High Speed DDR Mode

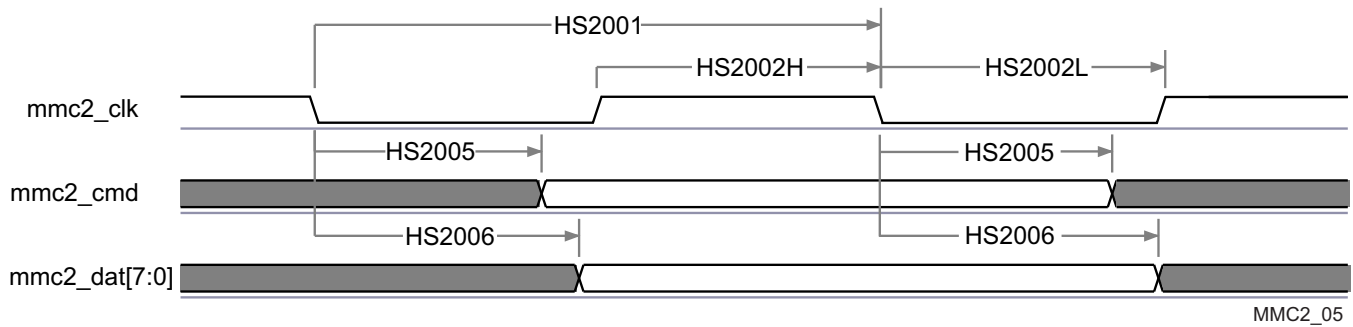
NO.	PARAMETER	DESCRIPTION	MODE	MIN	MAX	UNIT
DDR3	$t_{su(cmdV-clk)}$	Setup time, mmc2_cmd valid before mmc2_clk transition		1.8		ns
DDR4	$t_{h(clk-cmdV)}$	Hold time, mmc2_cmd valid after mmc2_clk transition		1.8		ns
DDR7	$t_{su(dV-clk)}$	Setup time, mmc2_dat[7:0] valid before mmc2_clk transition		1.8		ns
DDR8	$t_{h(clk-dV)}$	Hold time, mmc2_dat[7:0] valid after mmc2_clk transition	Pad Loopback (1.8V)	1.8 (1)		ns
			Pad Loopback (3.3V)	1.8		ns
			Internal Loopback	1.8 (1)		ns

(1) This Hold time requirement is larger than the Hold time provided by a typical eMMC component. Therefore, the trace length between the Device and eMMC component must be sufficiently long enough to ensure that the Hold time is met at the Device.

表 7-121. Switching Characteristics for MMC2 - JC64 High Speed DDR Mode

NO.	PARAMETER	DESCRIPTION	MIN	MAX	UNIT
DDR1	$f_{op(clk)}$	Operating frequency, mmc2_clk		48	MHz
DDR2H	$t_{w(clkH)}$	Pulse duration, mmc2_clk high	0.5*P- 0.172 (1)		ns
DDR2L	$t_{w(clkL)}$	Pulse duration, mmc2_clk low	0.5*P- 0.172 (1)		ns
DDR5	$t_{d(clk-cmdV)}$	Delay time, mmc2_clk transition to mmc2_cmd transition	2.9	7.14	ns
DDR6	$t_{d(clk-dV)}$	Delay time, mmc2_clk transition to mmc2_dat[7:0] transition	2.9	7.14	ns

(1) P = output mmc2_clk period in ns

表 7-122 和 表 7-123 呈现 Timing requirements and Switching characteristics for MMC2 - High speed DDR in receiver and transmitter mode During Boot (see 图 7-81 和 图 7-82).

表 7-122. Timing Requirements for MMC2 - JC64 High Speed DDR Mode During Boot

NO.	PARAMETER	DESCRIPTION	MODE	MIN	MAX	UNIT
DDR3	$t_{su(cmdV-clk)}$	Setup time, mmc2_cmd valid before mmc2_clk transition	Boot (1.8V)	1.8		ns
			Boot (3.3V)	1.8		ns
DDR4	$t_{h(clk-cmdV)}$	Hold time, mmc2_cmd valid after mmc2_clk transition	Boot (1.8V)	1.8 (1)		ns
			Boot (3.3V)	1.8 (1)		ns

表 7-122. Timing Requirements for MMC2 - JC64 High Speed DDR Mode During Boot (continued)

NO.	PARAMETER	DESCRIPTION	MODE	MIN	MAX	UNIT
DDR7	$t_{su(dV-clk)}$	Setup time, mmc2_dat[7:0] valid before mmc2_clk transition	Boot (1.8V)	1.8		ns
			Boot (3.3V)	1.8		ns
DDR8	$t_{h(clk-dV)}$	Hold time, mmc2_dat[7:0] valid after mmc2_clk transition	Boot (1.8V)	1.8 (1)		ns
			Boot (3.3V)	1.8 (1)		ns

(1) This Hold time requirement is larger than the Hold time provided by a typical eMMC component. Therefore, the trace length between the Device and eMMC component must be sufficiently long enough to ensure that the Hold time is met at the Device.

表 7-123. Switching Characteristics for MMC2 - JC64 High Speed DDR Mode During Boot

NO.	PARAMETER	DESCRIPTION	MODE	MIN	MAX	UNIT
DDR1	fop(clk)	Operating frequency, mmc2_clk			48	MHz
DDR2H	$t_{w(clkH)}$	Pulse duration, mmc2_clk high		0.5*P-0.172 (1)		ns
DDR2L	$t_{w(clkL)}$	Pulse duration, mmc2_clk low		0.5*P-0.172 (1)		ns
DDR5	$t_{d(clk-cmdV)}$	Delay time, mmc2_clk transition to mmc2_cmd transition	Boot (1.8V)	2.9	7.14	ns
			Boot (3.3V)	2.9	7.14	ns
DDR6	$t_{d(clk-dV)}$	Delay time, mmc2_clk transition to mmc2_dat[7:0] transition	Boot (1.8V)	2.9	7.14	ns
			Boot (3.3V)	2.9	7.14	ns

(1) P = output mmc2_clk period in ns

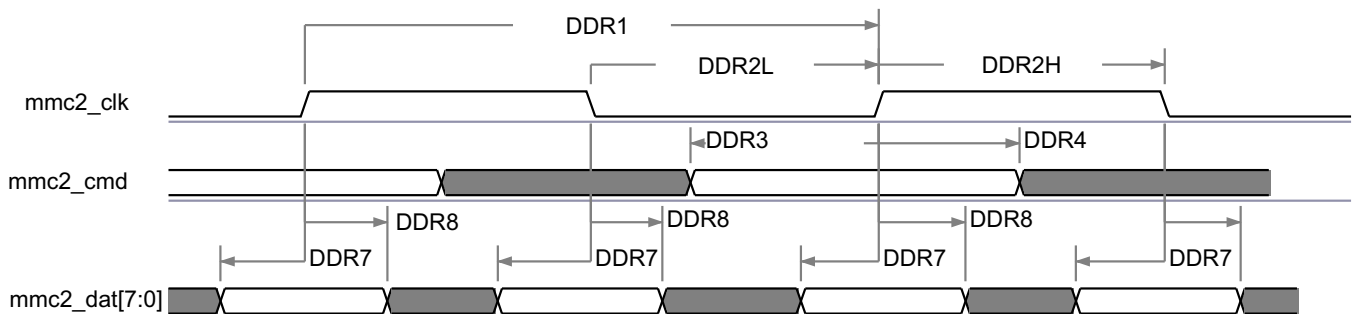

MMC2_07

图 7-81. MMC/SD/SDIO in - High Speed DDR JC64 - Receiver Mode

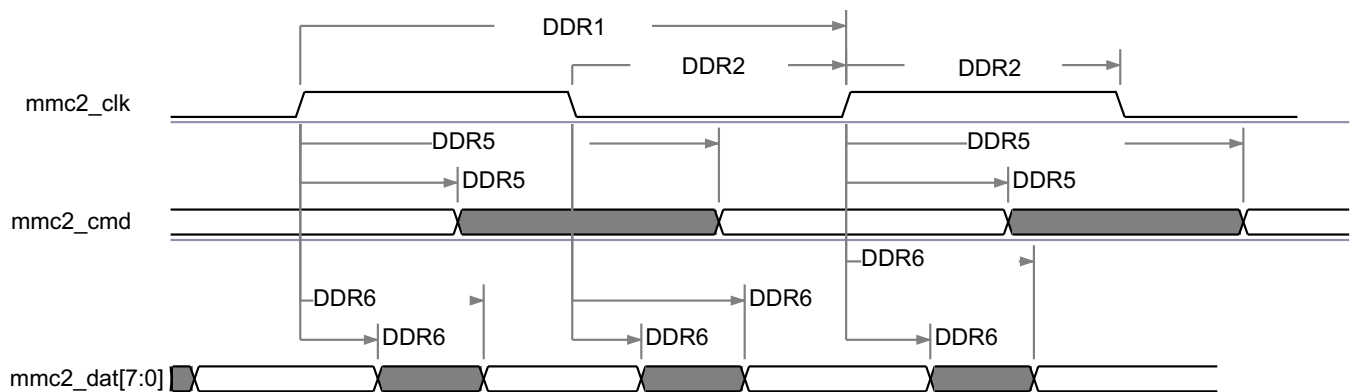

MMC2_08

图 7-82. MMC/SD/SDIO in - High Speed DDR JC64 - Transmitter Mode

注: To configure the desired Manual IO Timing Mode the user must follow the steps described in section Manual IO Timing Modes of the Device TRM.

The associated registers to configure are listed in the **CFG REGISTER** column. For more information see the Control Module chapter in the Device TRM.

Manual IO Timings Modes must be used to ensure some IO timings for MMC2. See [表 7-2 Modes Summary](#) for a list of IO timings requiring the use of Manual IO Timings Modes. See [表 7-124 Manual Functions Mapping for MMC2 with Internal Loopback Clock and for HS200](#) for a definition of the Manual modes.

[表 7-124](#) lists the A_DELAY and G_DELAY values needed to calculate the correct values to be set in the CFG_x registers.

表 7-124. Manual Functions Mapping for MMC2 With Internal Loopback Clock and for HS200

BALL	BALL NAME	MMC2_DDR_LB_MANUAL1		MMC2_STD_HS_LB_MANUAL1		MMC2_HS200_MANUAL1		CFG REGISTER	MUXMODE
		A_DELAY (ps)	G_DELAY (ps)	A_DELAY (ps)	G_DELAY (ps)	A_DELAY (ps)	G_DELAY (ps)		1
K7	gpmc_a19	49	0	850	0	-	-	CFG_GPMC_A19_IN	mmc2_dat4
K7	gpmc_a19	0	0	0	0	274	0	CFG_GPMC_A19_OEN	mmc2_dat4
K7	gpmc_a19	170	0	0	0	162	0	CFG_GPMC_A19_OUT	mmc2_dat4
M7	gpmc_a20	463	0	1264	0	-	-	CFG_GPMC_A20_IN	mmc2_dat5
M7	gpmc_a20	0	0	0	0	401	0	CFG_GPMC_A20_OEN	mmc2_dat5
M7	gpmc_a20	81	0	0	0	73	0	CFG_GPMC_A20_OUT	mmc2_dat5
J5	gpmc_a21	8	0	786	0	-	-	CFG_GPMC_A21_IN	mmc2_dat6
J5	gpmc_a21	0	0	0	0	465	0	CFG_GPMC_A21_OEN	mmc2_dat6
J5	gpmc_a21	123	0	0	0	115	0	CFG_GPMC_A21_OUT	mmc2_dat6
K6	gpmc_a22	0	102	902	0	-	-	CFG_GPMC_A22_IN	mmc2_dat7
K6	gpmc_a22	0	0	0	0	633	0	CFG_GPMC_A22_OEN	mmc2_dat7
K6	gpmc_a22	55	0	0	0	47	0	CFG_GPMC_A22_OUT	mmc2_dat7
J7	gpmc_a23	592	2815	0	2764	-	-	CFG_GPMC_A23_IN	mmc2_clk
J7	gpmc_a23	422	0	0	0	935	280	CFG_GPMC_A23_OUT	mmc2_clk
J4	gpmc_a24	384	0	1185	0	-	-	CFG_GPMC_A24_IN	mmc2_dat0
J4	gpmc_a24	0	0	0	0	621	0	CFG_GPMC_A24_OEN	mmc2_dat0
J4	gpmc_a24	0	0	0	0	0	0	CFG_GPMC_A24_OUT	mmc2_dat0
J6	gpmc_a25	0	0	670	0	-	-	CFG_GPMC_A25_IN	mmc2_dat1
J6	gpmc_a25	0	0	0	0	183	0	CFG_GPMC_A25_OEN	mmc2_dat1
J6	gpmc_a25	0	0	0	0	0	0	CFG_GPMC_A25_OUT	mmc2_dat1
H4	gpmc_a26	171	0	972	0	-	-	CFG_GPMC_A26_IN	mmc2_dat2
H4	gpmc_a26	0	0	0	0	467	0	CFG_GPMC_A26_OEN	mmc2_dat2
H4	gpmc_a26	0	0	0	0	0	0	CFG_GPMC_A26_OUT	mmc2_dat2
H5	gpmc_a27	315	0	1116	0	-	-	CFG_GPMC_A27_IN	mmc2_dat3
H5	gpmc_a27	0	0	0	0	262	0	CFG_GPMC_A27_OEN	mmc2_dat3
H5	gpmc_a27	54	0	0	0	46	0	CFG_GPMC_A27_OUT	mmc2_dat3
H6	gpmc_cs1	0	0	250	0	-	-	CFG_GPMC_CS1_IN	mmc2_cmd
H6	gpmc_cs1	0	0	0	0	684	0	CFG_GPMC_CS1_OEN	mmc2_cmd
H6	gpmc_cs1	0	0	0	0	76	0	CFG_GPMC_CS1_OUT	mmc2_cmd

7.24.3 MMC3 and MMC4—SDIO/SD

MMC3 and MMC4 interfaces are compliant with the SDIO3.0 standard v1.0, SD Part E1 and for generic SDIO devices, it supports the following applications:

- MMC3 8-bit data and MMC4 4-bit data, SD Default speed, SDR
- MMC3 8-bit data and MMC4 4-bit data, SD High speed, SDR
- MMC3 8-bit data and MMC4 4-bit data, UHS-1 SDR12 (SD Standard v3.01), 4-bit data, SDR, half cycle
- MMC3 8-bit data and MMC4 4-bit data, UHS-I SDR25 (SD Standard v3.01), 4-bit data, SDR, half cycle
- MMC3 8-bit data, UHS-I SDR50

注: The eMMC/SD/SDIOj (j = 3 to 4) controller is also referred to as MMCj.

注: For more information, see the MMC/SDIO chapter of the Device TRM.

7.24.3.1 MMC3 and MMC4, SD Default Speed

☒ 7-83, ☒ 7-84, and 表 7-125 through 表 7-128 present Timing requirements and Switching characteristics for MMC3 and MMC4 - SD Default speed in receiver and transmitter mode.

表 7-125. Timing Requirements for MMC3 - Default Speed Mode ⁽¹⁾

NO.	PARAMETER	DESCRIPTION	MIN	MAX	UNIT
DS5	$t_{su(cmdV-clkH)}$	Setup time, mmc3_cmd valid before mmc3_clk rising clock edge	5.11		ns
DS6	$t_h(clkH-cmdV)$	Hold time, mmc3_cmd valid after mmc3_clk rising clock edge	20.46		ns
DS7	$t_{su(dV-clkH)}$	Setup time, mmc3_dat[i:0] valid before mmc3_clk rising clock edge	5.11		ns
DS8	$t_h(clkH-dV)$	Hold time, mmc3_dat[i:0] valid after mmc3_clk rising clock edge	20.46		ns

(1) i in [i:0] = 7

表 7-126. Switching Characteristics for MMC3 - SD/SDIO Default Speed Mode ⁽²⁾

NO.	PARAMETER	DESCRIPTION	MIN	MAX	UNIT
DS0	fop(clk)	Operating frequency, mmc3_clk		24	MHz
DS1	$t_w(clkH)$	Pulse duration, mmc3_clk high	0.5*P-0.270 ⁽¹⁾		ns
DS2	$t_w(clkL)$	Pulse duration, mmc3_clk low	0.5*P-0.270 ⁽¹⁾		ns
DS3	$t_d(clkL-cmdV)$	Delay time, mmc3_clk falling clock edge to mmc3_cmd transition	-14.93	14.93	ns
DS4	$t_d(clkL-dV)$	Delay time, mmc3_clk falling clock edge to mmc3_dat[i:0] transition	-14.93	14.93	ns

(1) P = output mmc3_clk period in ns

(2) i in [i:0] = 7

表 7-127. Timing Requirements for MMC4 - Default Speed Mode ⁽¹⁾

NO.	PARAMETER	DESCRIPTION	MIN	MAX	UNIT
DS5	$t_{su(cmdV-clkH)}$	Setup time, mmc4_cmd valid before mmc4_clk rising clock edge	5.11		ns
DS6	$t_h(clkH-cmdV)$	Hold time, mmc4_cmd valid after mmc4_clk rising clock edge	20.46		ns
DS7	$t_{su(dV-clkH)}$	Setup time, mmc4_dat[i:0] valid before mmc4_clk rising clock edge	5.11		ns
DS8	$t_h(clkH-dV)$	Hold time, mmc4_dat[i:0] valid after mmc4_clk rising clock edge	20.46		ns

(1) i in $[i:0] = 3$

表 7-128. Switching Characteristics for MMC4 - Default Speed Mode ⁽²⁾

NO.	PARAMETER	DESCRIPTION	MIN	MAX	UNIT
DS0	fop(clk)	Operating frequency, mmc4_clk		24	MHz
DS1	t _w (clkH)	Pulse duration, mmc4_clk high	0.5*P-0.270 ⁽¹⁾		ns
DS2	t _w (clkL)	Pulse duration, mmc4_clk low	0.5*P-0.270 ⁽¹⁾		ns
DS3	t _d (clkL-cmdV)	Delay time, mmc4_clk falling clock edge to mmc4_cmd transition	-14.93	14.93	ns
DS4	t _d (clkL-dV)	Delay time, mmc4_clk falling clock edge to mmc4_dat[i:0] transition	-14.93	14.93	ns

(1) P = output mmc4_clk period in ns

(2) i in $[i:0] = 3$



图 7-83. MMC/SD/SDIOj in - Default Speed - Receiver Mode



图 7-84. MMC/SD/SDIOj in - Default Speed - Transmitter Mode

7.24.3.2 MMC3 and MMC4, SD High Speed

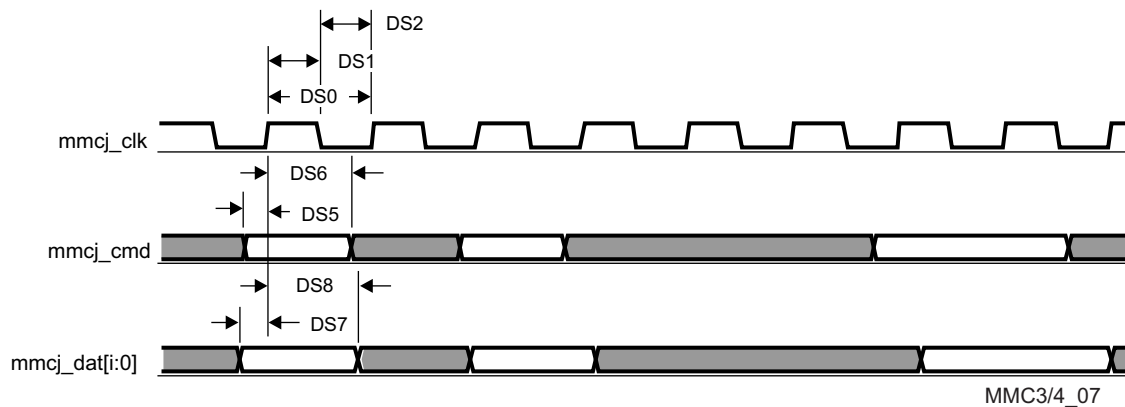
图 7-85, 图 7-86, and 表 7-129 through 表 7-132 present Timing requirements and Switching characteristics for MMC3 and MMC4 - SD and SDIO High speed in receiver and transmitter mode.

表 7-129. Timing Requirements for MMC3 - SD/SDIO High Speed Mode ⁽¹⁾

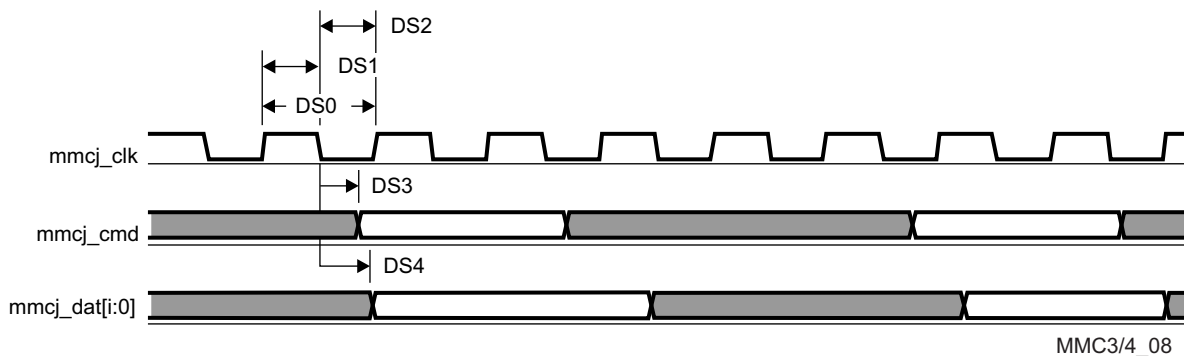
NO.	PARAMETER	DESCRIPTION	MIN	MAX	UNIT
HS3	t _{su} (cmdV-clkH)	Setup time, mmc3_cmd valid before mmc3_clk rising clock edge	5.3		ns
HS4	t _h (clkH-cmdV)	Hold time, mmc3_cmd valid after mmc3_clk rising clock edge	2.6		ns
HS7	t _{su} (dV-clkH)	Setup time, mmc3_dat[i:0] valid before mmc3_clk rising clock edge	5.3		ns
HS8	t _h (clkH-dV)	Hold time, mmc3_dat[i:0] valid after mmc3_clk rising clock edge	2.6		ns

(1) i in [i:0] = 7

表 7-130. Switching Characteristics for MMC3 - SD/SDIO High Speed Mode (2)

NO.	PARAMETER	DESCRIPTION	MIN	MAX	UNIT
HS1	fop(clk)	Operating frequency, mmc3_clk		48	MHz
HS2H	t _w (clkH)	Pulse duration, mmc3_clk high	0.5*P-0.270 (1)		ns
HS2L	t _w (clkL)	Pulse duration, mmc3_clk low	0.5*P-0.270 (1)		ns
HS5	t _d (clkL-cmdV)	Delay time, mmc3_clk falling clock edge to mmc3_cmd transition	-7.6	3.6	ns
HS6	t _d (clkL-dV)	Delay time, mmc3_clk falling clock edge to mmc3_dat[i:0] transition	-7.6	3.6	ns

(1) P = output mmc3_clk period in ns

(2) i in [i:0] = 7

表 7-131. Timing Requirements for MMC4 - High Speed Mode (1)

NO.	PARAMETER	DESCRIPTION	MIN	MAX	UNIT
HS3	t _{su} (cmdV-clkH)	Setup time, mmc4_cmd valid before mmc4_clk rising clock edge	5.3		ns
HS4	t _h (clkH-cmdV)	Hold time, mmc4_cmd valid after mmc4_clk rising clock edge	1.6		ns
HS7	t _{su} (dV-clkH)	Setup time, mmc4_dat[i:0] valid before mmc4_clk rising clock edge	5.3		ns
HS8	t _h (clkH-dV)	Hold time, mmc4_dat[i:0] valid after mmc4_clk rising clock edge	1.6		ns

(1) i in [i:0] = 3

表 7-132. Switching Characteristics for MMC4 - High Speed Mode (2)

NO.	PARAMETER	DESCRIPTION	MIN	MAX	UNIT
HS1	fop(clk)	Operating frequency, mmc4_clk		48	MHz
HS2H	t _w (clkH)	Pulse duration, mmc4_clk high	0.5*P-0.270 (1)		ns
HS2L	t _w (clkL)	Pulse duration, mmc4_clk low	0.5*P-0.270 (1)		ns
HS5	t _d (clkL-cmdV)	Delay time, mmc4_clk falling clock edge to mmc4_cmd transition	-8.8	6.6	ns
HS6	t _d (clkL-dV)	Delay time, mmc4_clk falling clock edge to mmc4_dat[i:0] transition	-8.8	6.6	ns

(1) P = output mmc4_clk period in ns

(2) i in [i:0] = 3



图 7-85. MMC/SD/SDIOj in - High Speed - Receiver Mode



图 7-86. MMC/SD/SDIOj in - High Speed - Transmitter Mode

7.24.3.3 MMC3 and MMC4, SD and SDIO SDR12 Mode

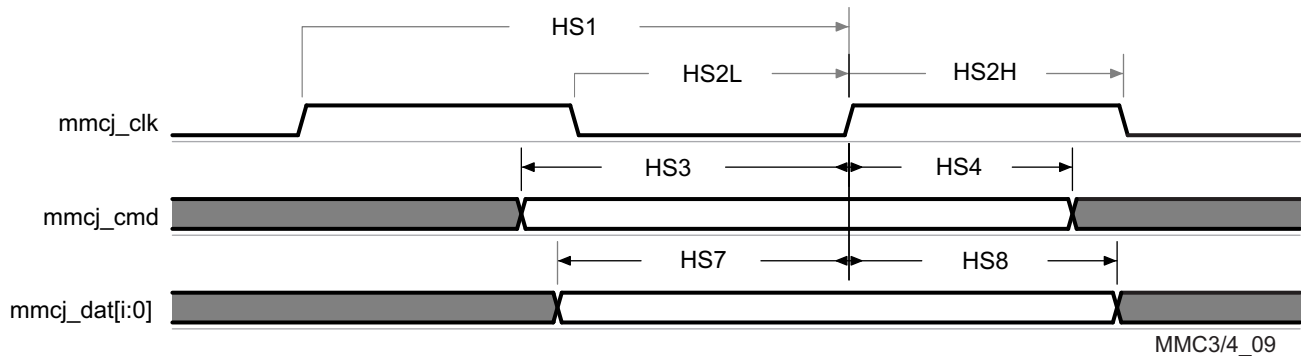
图 7-87, 图 7-88, and 表 7-133, through 表 7-136 present Timing requirements and Switching characteristics for MMC3 and MMC4 - SD and SDIO SDR12 in receiver and transmitter mode.

表 7-133. Timing Requirements for MMC3 - SDR12 Mode ⁽¹⁾

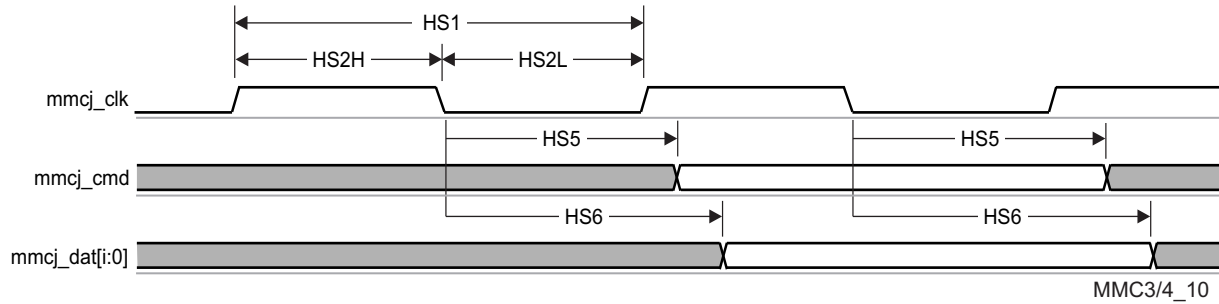
NO.	PARAMETER	DESCRIPTION	MIN	MAX	UNIT
SDR125	$t_{su}(cmdV-clkH)$	Setup time, mmc3_cmd valid before mmc3_clk rising clock edge	25.99		ns
SDR126	$t_h(clkH-cmdV)$	Hold time, mmc3_cmd valid after mmc3_clk rising clock edge	1.6		ns
SDR127	$t_{su}(dV-clkH)$	Setup time, mmc3_dat[i:0] valid before mmc3_clk rising clock edge	25.99		ns
SDR128	$t_h(clkH-dV)$	Hold time, mmc3_dat[i:0] valid after mmc3_clk rising clock edge	1.6		ns

(1) i in [i:0] = 7

表 7-134. Switching Characteristics for MMC3 - SDR12 Mode ⁽²⁾

NO.	PARAMETER	DESCRIPTION	MIN	MAX	UNIT
SDR120	fop(clk)	Operating frequency, mmc3_clk		24	MHz
SDR121	$t_w(clkH)$	Pulse duration, mmc3_clk high	0.5*P-0.270 ⁽¹⁾		ns
SDR122	$t_w(clkL)$	Pulse duration, mmc3_clk low	0.5*P-0.270 ⁽¹⁾		ns
SDR123	$t_d(clkL-cmdV)$	Delay time, mmc3_clk falling clock edge to mmc3_cmd transition	-19.13	16.93	ns
SDR124	$t_d(clkL-dV)$	Delay time, mmc3_clk falling clock edge to mmc3_dat[i:0] transition	-19.13	16.93	ns

(1) P = output mmc3_clk period in ns

(2) i in [i:0] = 7

表 7-135. Timing Requirements for MMC4 - SDR12 Mode ⁽¹⁾

NO.	PARAMETER	DESCRIPTION	MIN	MAX	UNIT
SDR125	$t_{su}(cmdV-clkH)$	Setup time, mmc4_cmd valid before mmc4_clk rising clock edge	25.99		ns
SDR126	$t_h(clkH-cmdV)$	Hold time, mmc4_cmd valid after mmc4_clk rising clock edge	1.6		ns
SDR127	$t_{su}(dV-clkH)$	Setup time, mmc4_dat[i:0] valid before mmc4_clk rising clock edge	25.99		ns
SDR128	$t_h(clkH-dV)$	Hold time, mmc4_dat[i:0] valid after mmc4_clk rising clock edge	1.6		ns

(1) j in [i:0] = 3

表 7-136. Switching Characteristics for MMC4 - SDR12 Mode ⁽²⁾

NO.	PARAMETER	DESCRIPTION	MIN	MAX	UNIT
SDR120	fop(clk)	Operating frequency, mmc4_clk		24	MHz
SDR121	$t_w(clkH)$	Pulse duration, mmc4_clk high	0.5*P-0.270 ⁽¹⁾		ns
SDR122	$t_w(clkL)$	Pulse duration, mmc4_clk low	0.5*P-0.270 ⁽¹⁾		ns

表 7-136. Switching Characteristics for MMC4 - SDR12 Mode ⁽²⁾ (continued)

NO.	PARAMETER	DESCRIPTION	MIN	MAX	UNIT
SDR125	$t_{d(\text{clkL-cmdV})}$	Delay time, mmc4_clk falling clock edge to mmc4_cmd transition	-19.13	16.93	ns
SDR126	$t_{d(\text{clkL-dV})}$	Delay time, mmc4_clk falling clock edge to mmc4_dat[i:0] transition	-19.13	16.93	ns

(1) P = output mmc4_clk period in ns

(2) j in [i:0] = 3



图 7-87. MMC/SD/SDIOj in - SDR12 - Receiver Mode



图 7-88. MMC/SD/SDIOj in - SDR12 - Transmitter Mode

7.24.3.4 MMC3 and MMC4, SD SDR25 Mode

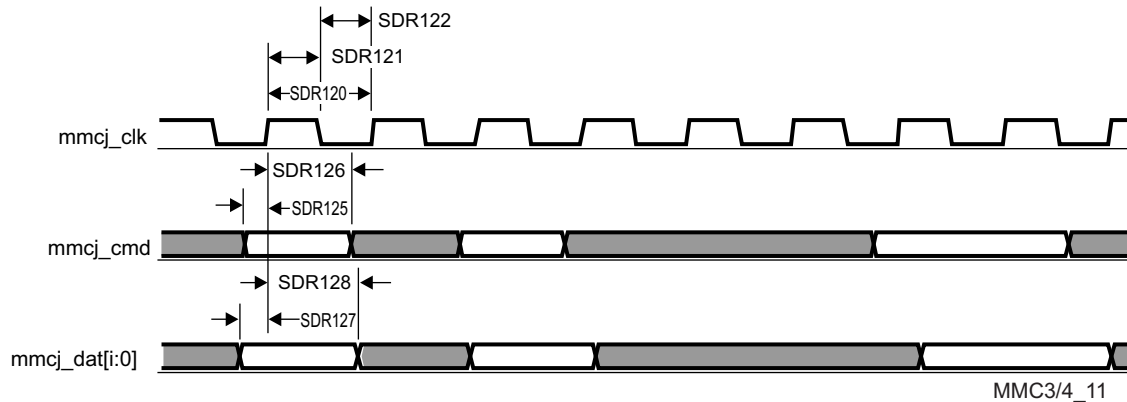
图 7-89, 图 7-90, and 表 7-137 through 表 7-140 present Timing requirements and Switching characteristics for MMC3 and MMC4 - SD and SDIO SDR25 in receiver and transmitter mode.

表 7-137. Timing Requirements for MMC3 - SDR25 Mode ⁽¹⁾

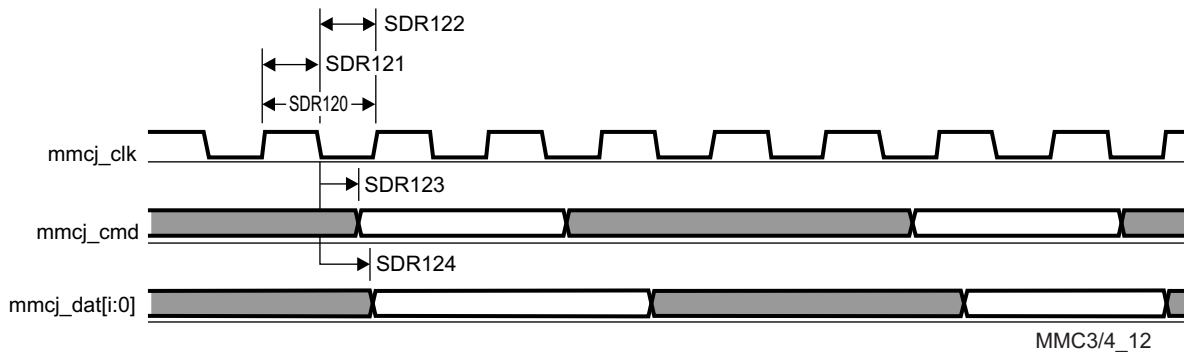
NO.	PARAMETER	DESCRIPTION	MIN	MAX	UNIT
SDR253	$t_{su(\text{cmdV-clkH})}$	Setup time, mmc3_cmd valid before mmc3_clk rising clock edge	5.3		ns
SDR254	$t_{h(\text{clkH-cmdV})}$	Hold time, mmc3_cmd valid after mmc3_clk rising clock edge	1.6		ns
SDR257	$t_{su(\text{dV-clkH})}$	Setup time, mmc3_dat[i:0] valid before mmc3_clk rising clock edge	5.3		ns
SDR258	$t_{h(\text{clkH-dV})}$	Hold time, mmc3_dat[i:0] valid after mmc3_clk rising clock edge	1.6		ns

(1) i in [i:0] = 7

表 7-138. Switching Characteristics for MMC3 - SDR25 Mode ⁽²⁾

NO.	PARAMETER	DESCRIPTION	MIN	MAX	UNIT
SDR251	fop(clk)	Operating frequency, mmc3_clk		48	MHz

表 7-138. Switching Characteristics for MMC3 - SDR25 Mode ⁽²⁾ (continued)

NO.	PARAMETER	DESCRIPTION	MIN	MAX	UNIT
SDR252 H	$t_{w(\text{clkH})}$	Pulse duration, mmc3_clk high	0.5*P- 0.270	⁽¹⁾	ns
SDR252L	$t_{w(\text{clkL})}$	Pulse duration, mmc3_clk low	0.5*P- 0.270	⁽¹⁾	ns
SDR255	$t_{d(\text{clkL-cmdV})}$	Delay time, mmc3_clk falling clock edge to mmc3_cmd transition	-8.8	6.6	ns
SDR256	$t_{d(\text{clkL-dV})}$	Delay time, mmc3_clk falling clock edge to mmc3_dat[i:0] transition	-8.8	6.6	ns

(1) P = output mmc3_clk period in ns

(2) i in [i:0] = 7

表 7-139. Timing Requirements for MMC4 - SDR25 Mode ⁽¹⁾

NO.	PARAMETER	DESCRIPTION	MIN	MAX	UNIT
SDR255	$t_{su(\text{cmdV-clkH})}$	Setup time, mmc4_cmd valid before mmc4_clk rising clock edge	5.3		ns
SDR256	$t_h(\text{clkH-cmdV})$	Hold time, mmc4_cmd valid after mmc4_clk rising clock edge	1.6		ns
SDR257	$t_{su(\text{dV-clkH})}$	Setup time, mmc4_dat[i:0] valid before mmc4_clk rising clock edge	5.3		ns
SDR258	$t_h(\text{clkH-dV})$	Hold time, mmc4_dat[i:0] valid after mmc4_clk rising clock edge	1.6		ns

(1) i in [i:0] = 3

表 7-140. Switching Characteristics for MMC4 - SDR25 Mode ⁽²⁾

NO.	PARAMETER	DESCRIPTION	MIN	MAX	UNIT
SDR251	fop(clk)	Operating frequency, mmc4_clk		48	MHz
SDR252 H	$t_{w(\text{clkH})}$	Pulse duration, mmc4_clk high	0.5*P- 0.270 ⁽¹⁾		ns
SDR252L	$t_{w(\text{clkL})}$	Pulse duration, mmc4_clk low	0.5*P- 0.270 ⁽¹⁾		ns
SDR255	$t_{d(\text{clkL-cmdV})}$	Delay time, mmc4_clk falling clock edge to mmc4_cmd transition	-8.8	6.6	ns
SDR256	$t_{d(\text{clkL-dV})}$	Delay time, mmc4_clk falling clock edge to mmc4_dat[i:0] transition	-8.8	6.6	ns

(1) P = output mmc4_clk period in ns

(2) i in [i:0] = 3



图 7-89. MMC/SD/SDIOj in - SDR25 - Receiver Mode



图 7-90. MMC/SD/SDIOj in - SDR25 - Transmitter Mode

7.24.3.5 MMC3 SDIO High-Speed UHS-I SDR50 Mode, Half Cycle

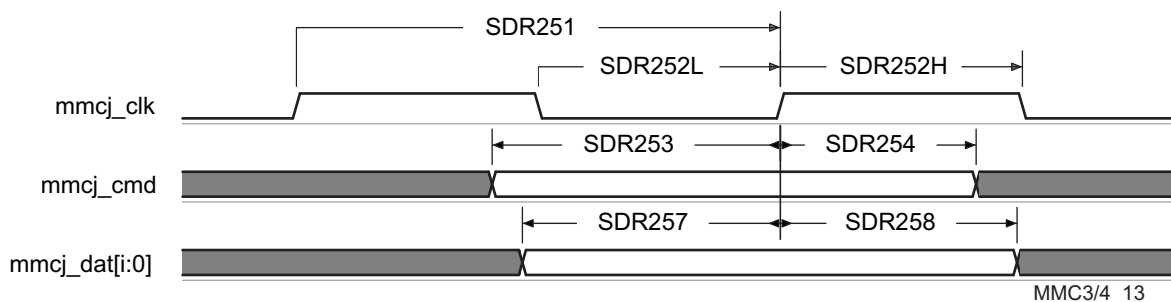
图 7-91, 图 7-92, 表 7-141, and 表 7-142 present Timing requirements and Switching characteristics for MMC3 - SDIO High speed SDR50 in receiver and transmitter mode.

表 7-141. Timing Requirements for MMC3 - SDR50 Mode ⁽¹⁾

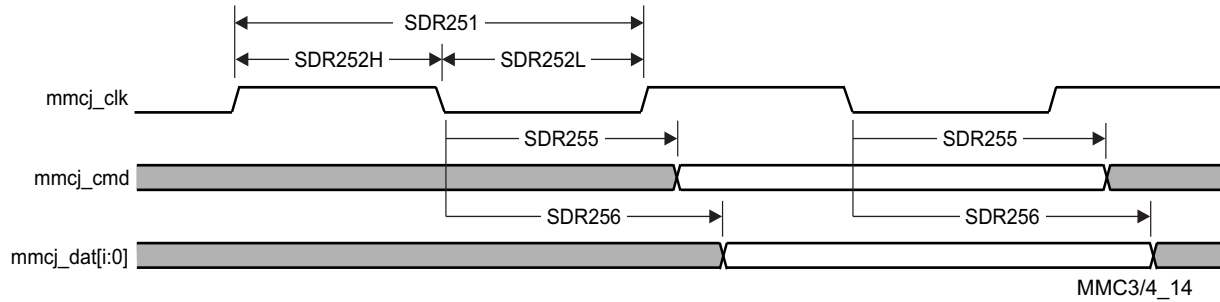
NO.	PARAMETER	DESCRIPTION	MIN	MAX	UNIT
SDR503	$t_{su}(cmdV-clkH)$	Setup time, mmc3_cmd valid before mmc3_clk rising clock edge	1.48		ns
SDR504	$t_h(clkH-cmdV)$	Hold time, mmc3_cmd valid after mmc3_clk rising clock edge	1.6		ns
SDR507	$t_{su}(dV-clkH)$	Setup time, mmc3_dat[i:0] valid before mmc3_clk rising clock edge	1.48		ns
SDR508	$t_h(clkH-dV)$	Hold time, mmc3_dat[i:0] valid after mmc3_clk rising clock edge	1.6		ns

(1) i in [i:0] = 7

表 7-142. Switching Characteristics for MMC3 - SDR50 Mode ⁽²⁾

NO.	PARAMETER	DESCRIPTION	MIN	MAX	UNIT
SDR501	fop(clk)	Operating frequency, mmc3_clk		64	MHz
SDR502H	$t_w(clkH)$	Pulse duration, mmc3_clk high	0.5*P-0.270 ⁽¹⁾		ns
SDR502L	$t_w(clkL)$	Pulse duration, mmc3_clk low	0.5*P-0.270 ⁽¹⁾		ns
SDR505	$t_d(clkL-cmdV)$	Delay time, mmc3_clk falling clock edge to mmc3_cmd transition	-3.66	1.46	ns
SDR506	$t_d(clkL-dV)$	Delay time, mmc3_clk falling clock edge to mmc3_dat[i:0] transition	-3.66	1.46	ns

(1) P = output mmc3_clk period in ns

(2) i in [i:0] = 7



图 7-91. MMC/SD/SDIOj in - High Speed SDR50 - Receiver Mode



图 7-92. MMC/SD/SDIOj in - High Speed SDR50 - Transmitter Mode

注: To configure the desired Manual IO Timing Mode the user must follow the steps described in section Manual IO Timing Modes of the Device TRM.

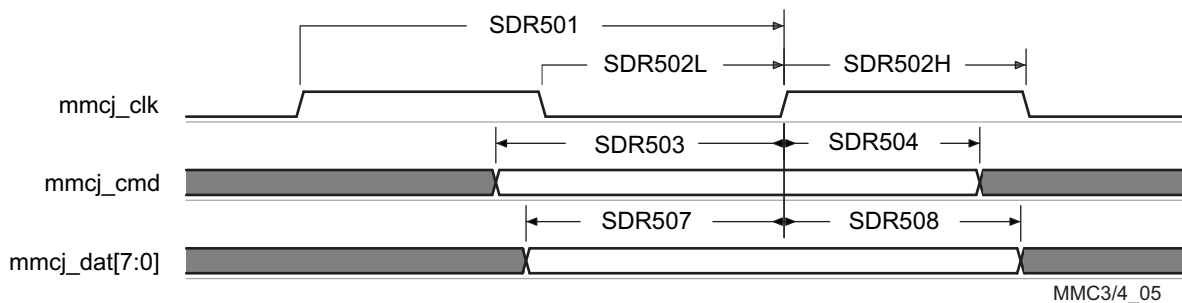
The associated registers to configure are listed in the **CFG REGISTER** column. For more information see the Control Module chapter in the Device TRM.

Manual IO Timings Modes must be used to ensure some IO timings for MMC3. See 表 7-2 *Modes Summary* for a list of IO timings requiring the use of Manual IO Timings Modes. See 表 7-143 *Manual Functions Mapping for MMC3* for a definition of the Manual modes.

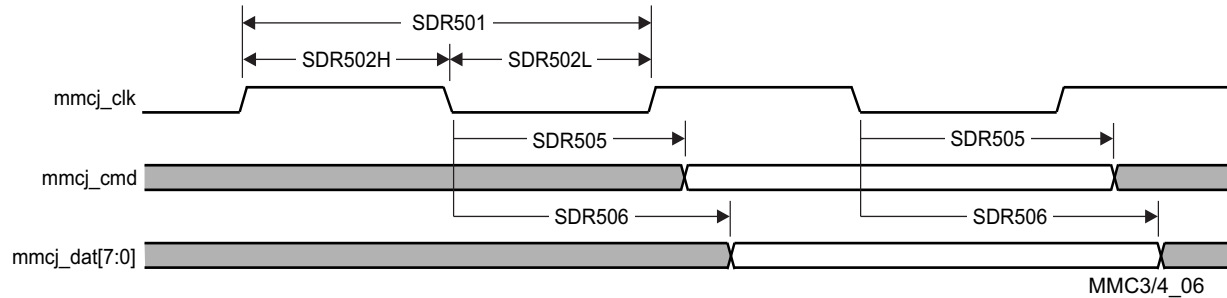
表 7-143 lists the A_DELAY and G_DELAY values needed to calculate the correct values to be set in the CFG_x registers.

表 7-143. Manual Functions Mapping for MMC3

BALL	BALL NAME	MMC3_MANUAL1		CFG REGISTER	MUXMODE
		A_DELAY (ps)	G_DELAY (ps)		0
AD4	mmc3_clk	0	386	CFG_MMC3_CLK_IN	mmc3_clk
AD4	mmc3_clk	605	0	CFG_MMC3_CLK_OUT	mmc3_clk
AC4	mmc3_cmd	0	0	CFG_MMC3_CMD_IN	mmc3_cmd
AC4	mmc3_cmd	0	0	CFG_MMC3_CMD_OEN	mmc3_cmd
AC4	mmc3_cmd	0	0	CFG_MMC3_CMD_OUT	mmc3_cmd
AC7	mmc3_dat0	171	0	CFG_MMC3_DAT0_IN	mmc3_dat0
AC7	mmc3_dat0	0	0	CFG_MMC3_DAT0_OEN	mmc3_dat0
AC7	mmc3_dat0	0	0	CFG_MMC3_DAT0_OUT	mmc3_dat0
AC6	mmc3_dat1	221	0	CFG_MMC3_DAT1_IN	mmc3_dat1
AC6	mmc3_dat1	0	0	CFG_MMC3_DAT1_OEN	mmc3_dat1
AC6	mmc3_dat1	0	0	CFG_MMC3_DAT1_OUT	mmc3_dat1
AC9	mmc3_dat2	0	0	CFG_MMC3_DAT2_IN	mmc3_dat2
AC9	mmc3_dat2	0	0	CFG_MMC3_DAT2_OEN	mmc3_dat2
AC9	mmc3_dat2	0	0	CFG_MMC3_DAT2_OUT	mmc3_dat2
AC3	mmc3_dat3	474	0	CFG_MMC3_DAT3_IN	mmc3_dat3
AC3	mmc3_dat3	0	0	CFG_MMC3_DAT3_OEN	mmc3_dat3
AC3	mmc3_dat3	0	0	CFG_MMC3_DAT3_OUT	mmc3_dat3
AC8	mmc3_dat4	792	0	CFG_MMC3_DAT4_IN	mmc3_dat4
AC8	mmc3_dat4	0	0	CFG_MMC3_DAT4_OEN	mmc3_dat4
AC8	mmc3_dat4	0	0	CFG_MMC3_DAT4_OUT	mmc3_dat4
AD6	mmc3_dat5	782	0	CFG_MMC3_DAT5_IN	mmc3_dat5
AD6	mmc3_dat5	0	0	CFG_MMC3_DAT5_OEN	mmc3_dat5
AD6	mmc3_dat5	0	0	CFG_MMC3_DAT5_OUT	mmc3_dat5
AB8	mmc3_dat6	942	0	CFG_MMC3_DAT6_IN	mmc3_dat6

表 7-143. Manual Functions Mapping for MMC3 (continued)

BALL	BALL NAME	MMC3_MANUAL1		CFG REGISTER	MUXMODE
		A_DELAY (ps)	G_DELAY (ps)		0
AB8	mmc3_dat6	0	0	CFG_MMC3_DAT6_OEN	mmc3_dat6
AB8	mmc3_dat6	0	0	CFG_MMC3_DAT6_OUT	mmc3_dat6
AB5	mmc3_dat7	636	0	CFG_MMC3_DAT7_IN	mmc3_dat7
AB5	mmc3_dat7	0	0	CFG_MMC3_DAT7_OEN	mmc3_dat7
AB5	mmc3_dat7	0	0	CFG_MMC3_DAT7_OUT	mmc3_dat7

Manual IO Timings Modes must be used to ensure some IO timings for MMC4. See [表 7-2 Modes Summary](#) for a list of IO timings requiring the use of Manual IO Timings Modes. See [表 7-144 Manual Functions Mapping for MMC4](#) for a definition of the Manual modes.

[表 7-144](#) lists the A_DELAY and G_DELAY values needed to calculate the correct values to be set in the CFG_x registers.

表 7-144. Manual Functions Mapping for MMC4

BALL	BALL NAME	MMC4_MANUAL1		MMC4_DS_MANUAL1		CFG REGISTER	MUXMODE
		A_DELAY (ps)	G_DELAY (ps)	A_DELAY (ps)	G_DELAY (ps)		3
E25	uart1_ctsn	0	0	0	0	CFG_UART1_CTSN_IN	mmc4_clk
E25	uart1_ctsn	1147	0	0	0	CFG_UART1_CTSN_OUT	mmc4_clk
C27	uart1_rtsn	1834	0	307	0	CFG_UART1_RTSN_IN	mmc4_cmd
C27	uart1_rtsn	0	0	0	0	CFG_UART1_RTSN_OEN	mmc4_cmd
C27	uart1_rtsn	0	0	0	0	CFG_UART1_RTSN_OUT	mmc4_cmd
D27	uart2_ctsn	2165	0	785	0	CFG_UART2_CTSN_IN	mmc4_dat2
D27	uart2_ctsn	0	0	0	0	CFG_UART2_CTSN_OEN	mmc4_dat2
D27	uart2_ctsn	0	0	0	0	CFG_UART2_CTSN_OUT	mmc4_dat2
C28	uart2_rtsn	1929	64	613	0	CFG_UART2_RTSN_IN	mmc4_dat3
C28	uart2_rtsn	0	0	0	0	CFG_UART2_RTSN_OEN	mmc4_dat3
C28	uart2_rtsn	0	0	0	0	CFG_UART2_RTSN_OUT	mmc4_dat3
D28	uart2_rxd	1935	128	683	0	CFG_UART2_RXD_IN	mmc4_dat0
D28	uart2_rxd	0	0	0	0	CFG_UART2_RXD_OEN	mmc4_dat0
D28	uart2_rxd	0	0	0	0	CFG_UART2_RXD_OUT	mmc4_dat0
D26	uart2_txd	2172	44	835	0	CFG_UART2_TXD_IN	mmc4_dat1
D26	uart2_txd	0	0	0	0	CFG_UART2_TXD_OEN	mmc4_dat1
D26	uart2_txd	0	0	0	0	CFG_UART2_TXD_OUT	mmc4_dat1

7.25 General-Purpose Interface (GPIO)

The general-purpose interface combines eight general-purpose input/output (GPIO) banks. Each GPIO module provides 32 dedicated general-purpose pins with input and output capabilities; thus, the general-purpose interface supports up to 247 pins.

These pins can be configured for the following applications:

- Data input (capture)/output (drive)
- Keyboard interface with a debounce cell
- Interrupt generation in active mode upon the detection of external events. Detected events are processed by two parallel independent interrupt-generation submodules to support biprocessor operations
- Wake-up request generation in idle mode upon the detection of external events

注: For more information, see the General-Purpose Interface chapter of the Device TRM.

注: The general-purpose input/output i (i = 1 to 8) bank is also referred to as GPIOi.

7.26 Audio Tracking Logic (ATL)

The device contains four ATL modules that can be used for asynchronous sample rate conversion of audio. The ATL calculates the error between two time bases, such as audio syncs, and optionally generates an averaged clock using cycle stealing via software.

注: For more detailed information on the ATL peripheral, see the Audio Tracking Logic (ATL) chapter of the device-specific Technical Reference Manual.

注: Audio Tracking Logic x (x= 1 to 4) module is also referred to as ATLx.

7.26.1 ATL Electrical Data/Timing

表 7-145 和 图 7-93 呈现 switching 特性 for ATL

表 7-145. Switching Characteristics Over Recommended Operating Conditions for ATL_CLKOUTx

NO.	PARAMETER	DESCRIPTION	MIN	MAX	UNIT
1	$t_{c(ATLCLKOUT)}$	Cycle time, ATL_CLKOUTx	20		ns
2	$t_{w(ATLCLKOUTL)}$	Pulse Duration, ATL_CLKOUTx low	$0.45 * P - M^{(1)}$		ns
3	$t_{w(ATLCLKOUTH)}$	Pulse Duration, ATL_CLKOUTx high	$0.45 * P - M^{(1)}$		ns

(1) P = ATL_CLKOUTx period.

M = internal ATL PCLK period.



图 7-93. ATL_CLKOUTx Timing

7.27 System and Miscellaneous interfaces

The Device includes the following System and Miscellaneous interfaces:

- Sysboot Interface
- System DMA Interface
- Interrupt Controllers (INTC) Interface
- Observability Signal (OBS) Interface

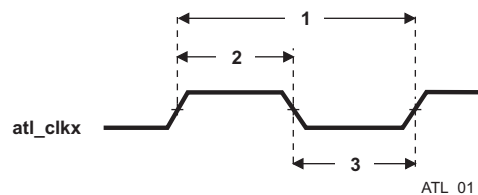
7.28 Test Interfaces

The Device includes the following Test interfaces:

- IEEE 1149.1 Standard-Test-Access Port (JTAG)
- Trace Port Interface Unit (TPIU)
- Advanced Event Triggering Interface (AET)

7.28.1 IEEE 1149.1 Standard-Test-Access Port (JTAG)

The JTAG (IEEE Standard 1149.1-1990 Standard-Test-Access Port and Boundary Scan Architecture) interface is used for BSDL testing and emulation of the device. The *trstn* pin only needs to be released when it is necessary to use a JTAG controller to debug the device or exercise the device's boundary scan functionality. For maximum reliability, the device includes an internal Pulldown (IPD) on the *trstn* pin to ensure that *trstn* is always asserted upon power up and the device's internal emulation logic is always properly initialized. JTAG controllers from Texas Instruments actively drive *trstn* high. However, some third-party JTAG controllers may not drive *trstn* high but expect the use of a Pullup resistor on *trstn*. When using this type of JTAG controller, assert *trstn* to initialize the device after powerup and externally drive *trstn* high before attempting any emulation or boundary-scan operations.

The main JTAG features include:

- 32KB embedded trace buffer (ETB™)
- 5-pin system trace interface for debug
- Supports Advanced Event Triggering (AET)
- All processors can be emulated via JTAG ports
- All functions on EMU pins of the device:
 - EMU[1:0] - cross-triggering, boot mode (WIR), STM trace
 - EMU[4:2] - STM trace only (single direction)

7.28.1.1 JTAG Electrical Data/Timing

表 7-146, 表 7-147 和 图 7-94 假设测试 over 的 recommended operating conditions and electrical characteristic conditions below.

表 7-146. Timing Requirements for IEEE 1149.1 JTAG

NO.	PARAMETER	DESCRIPTION	MIN	MAX	UNIT
1	$t_c(\text{TCK})$	Cycle time, TCK	62.29		ns
1a	$t_w(\text{TCKH})$	Pulse duration, TCK high (40% of t_c)	24.92		ns
1b	$t_w(\text{TCKL})$	Pulse duration, TCK low (40% of t_c)	24.92		ns
3	$t_{su}(\text{TDI-TCK})$	Input setup time, TDI valid to TCK high	6.23		ns
	$t_{su}(\text{TMS-TCK})$	Input setup time, TMS valid to TCK high	6.23		ns
4	$t_h(\text{TCK-TDI})$	Input hold time, TDI valid from TCK high	31.15		ns
	$t_h(\text{TCK-TMS})$	Input hold time, TMS valid from TCK high	31.15		ns

表 7-147. Switching Characteristics Over Recommended Operating Conditions for IEEE 1149.1 JTAG

NO.	PARAMETER	DESCRIPTION	MIN	MAX	UNIT
2	$t_d(\text{TCKL-TDOV})$	Delay time, TCK low to TDO valid	0	30.5	ns

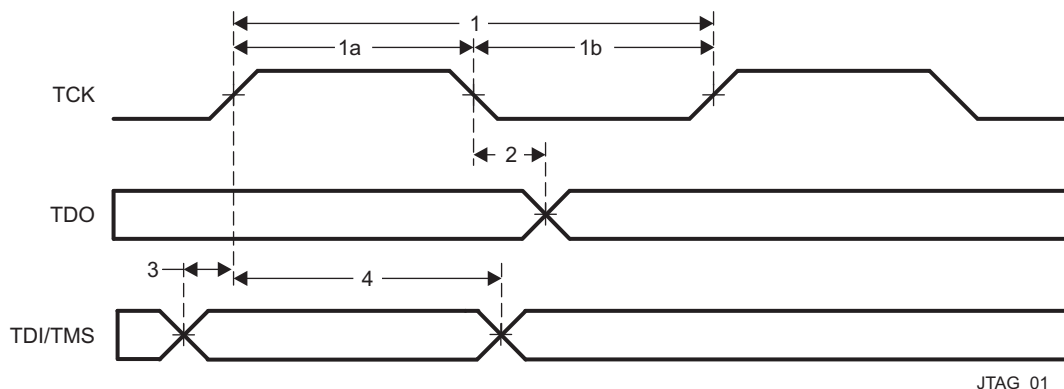

JTAG_01

图 7-94. JTAG Timing

表 7-148, 表 7-149 和 图 7-95 assume testing over the recommended operating conditions and electrical characteristic conditions below.

表 7-148. Timing Requirements for IEEE 1149.1 JTAG With RTCK

NO.	PARAMETER	DESCRIPTION	MIN	MAX	UNIT
1	$t_c(\text{TCK})$	Cycle time, TCK	62.29		ns
1a	$t_w(\text{TCKH})$	Pulse duration, TCK high (40% of t_c)	24.92		ns
1b	$t_w(\text{TCKL})$	Pulse duration, TCK low (40% of t_c)	24.92		ns
3	$t_{su}(\text{TDI-TCK})$	Input setup time, TDI valid to TCK high	6.23		ns
	$t_{su}(\text{TMS-TCK})$	Input setup time, TMS valid to TCK high	6.23		ns
4	$t_h(\text{TCK-TDI})$	Input hold time, TDI valid from TCK high	31.15		ns
	$t_h(\text{TCK-TMS})$	Input hold time, TMS valid from TCK high	31.15		ns

表 7-149. Switching Characteristics Over Recommended Operating Conditions for IEEE 1149.1 JTAG With RTCK

NO.	PARAMETER	DESCRIPTION	MIN	MAX	UNIT
5	$t_d(\text{TCK-RTCK})$	Delay time, TCK to RTCK with no selected subpaths (ICEPick is the only tap selected - when the Arm is in the scan chain, the delay time is a function of the Arm functional clock).	0	27	ns
6	$t_c(\text{RTCK})$	Cycle time, RTCK	62.29		ns
7	$t_w(\text{RTCKH})$	Pulse duration, RTCK high (40% of t_c)	24.92		ns
8	$t_w(\text{RTCKL})$	Pulse duration, RTCK low (40% of t_c)	24.92		ns



图 7-95. JTAG With RTCK Timing

7.28.2 Trace Port Interface Unit (TPIU)

注意

The I/O timings provided in this section are valid only if signals within a single IOSET are used. The IOSETs are defined in 表 7-151.

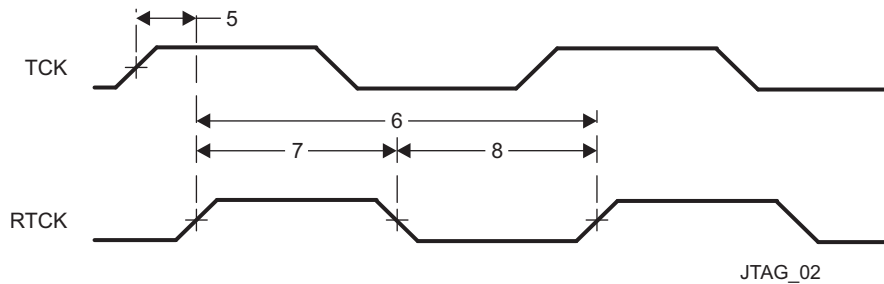
7.28.2.1 TPIU PLL DDR Mode

表 7-150 和 图 7-96 assume testing over the recommended operating conditions and electrical characteristic conditions below.

表 7-150. Switching Characteristics for TPIU

NO.	PARAMETER	DESCRIPTION	MIN	MAX	UNIT
TPIU1	$t_c(\text{clk})$	Cycle time, TRACECLK period	5.56		ns
TPIU4	$t_d(\text{clk-ctlV})$	Skew time, TRACECLK transition to TRACECTL transition	-0.96	0.96	ns

表 7-150. Switching Characteristics for TPIU (continued)

NO.	PARAMETER	DESCRIPTION	MIN	MAX	UNIT
TPIU5	$t_{d(\text{clk-dataV})}$	Skew time, TRACECLK transition to TRACEDATA[17:0]	-0.96	0.96	ns



图 7-96. TPIU—PLL DDR Transmit Mode⁽¹⁾

(1) In d[X:0], X is equal to 15 or 17.

In 表 7-151 are presented the specific groupings of signals (IOSET) for use with TPIU signals.

表 7-151. TPIU IOSETS

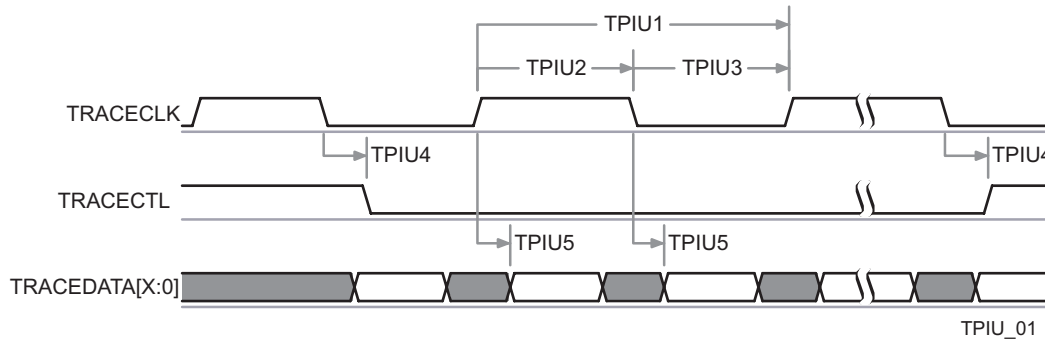
SIGNALS	IOSET1		IOSET2	
	BALL	MUX	BALL	MUX
emu0	G21	0	G21	0
emu1	D24	0	D24	0
emu2	F10	2	F10	2
emu3	D7	2	D7	2
emu4	A7	2	A7	2
emu5	E1	5	G11	2
emu6	G2	5	E9	2
emu7	H7	5	F9	2
emu8	G1	5	F8	2
emu9	G6	5	E7	2
emu10	F2	5	D8	2
emu11	F3	5	A5	2
emu12	D1	5	C6	2
emu13	E2	5	C8	2
emu14	D2	5	C7	2
emu15	F4	5	A8	2
emu16	C1	5	C9	2
emu17	E4	5	A9	2
emu18	F5	5	B9	2
emu19	E6	5	A10	2

8 Applications, Implementation, and Layout

注: Information in the following applications sections is not part of the TI component specification, and TI does not warrant its accuracy or completeness. TI's customers are responsible for determining suitability of components for their purposes. Customers should validate and test design implementation to confirm system functionality.

8.1 Introduction

This chapter is intended to communicate, guide and illustrate a PCB design strategy resulting in a PCB that can support TI's latest Application Processor. This Processor is a high-performance processor designed for automotive Infotainment and Advanced Driver Assistance Systems based on enhanced OMAP™ architecture integrated on a 28-nm CMOS process technology.

These guidelines first focus on designing a robust Power Delivery Network (PDN) which is essential to achieve the desirable high performance processing available on Device. The general principles and step-by-step approach for implementing good power integrity (PI) with specific requirements will be described for the key Device power domains.

TI strongly believes that simulating a PCB's proposed PDN is required for first pass PCB design success. Key Device processor high-current power domains need to be evaluated for Power Rail IR Drop, Decoupling Capacitor Loop-Inductance and Power Rail Target Impedance. Only then can a PCB's PDN performance be truly accessed by comparing these model PI parameters vs. TI's recommended values. Ultimately for any high-volume product, TI recommends conducting a "Processor PDN Validation" test on prototype PCBs across processor "split lots" to verify PDN robustness meets desired performance goals for each customer's worst-case scenario. Please contact your TI representative to receive guidance on PDN PI modeling and validation testing.

Likewise, the methodology and requirements needed to route Device high-speed, differential interfaces (i.e. USB2.0, USB3.0, HDMI, PCI, SATA), single-ended interfaces (i.e. DDR2/DDR3, QSPI) and general purpose interfaces using LVCMOS drivers that meet timing requirements while minimizing signal integrity (SI) distortions on the PCB's signaling traces. Signal trace lengths and flight times are aligned with FR-4 standard specification for PCBs.

Several different PCB layout stack-up examples have been presented to illustrate a typical number of layers, signal assignments and controlled impedance requirements. Different Device interface signals demand more or less complexity for routing and controlled impedance stack-ups. Optimizing the PCB's PDN stack-up needs with all of these different types of signal interfaces will ultimately determine the final layer count and layer assignments in each customer's PCB design.

This guideline must be used as a supplement in complement to TI's Application Processor, Power Management IC (PMIC) and Audio Companion components along with other TI component technical documentation (i.e. Technical Reference Manual, Data Manual, Data Sheets, Silicon Errata, Pin-Out Spreadsheet, Application Notes, etc.).

注: Notwithstanding any provision to the contrary, TI makes no warranty expressed, implied, or statutory, including any implied warranty of merchantability of fitness for a specific purpose, for customer boards. The data described in this appendix are intended as guidelines only.

注: These PCB guidelines are in a draft maturity and consequently, are subject to change depending on design verification testing conducted during IC development and validation. Note also that any references to Application Processor's ballout or pin muxing are subject to change following the processor's ballout maturity.

8.1.1 Initial Requirements and Guidelines

Unless otherwise specified, the characteristic impedance for single-ended interfaces is recommended to be between 35 Ω and 65 Ω to minimize the overshoot or undershoot on far-end loads.

Characteristic impedance for differential interfaces must be routed as differential traces on the same layer. The trace width and spacing must be chosen to yield the recommended differential impedance. For more information see [8.5.1](#).

The PDN must be optimized for low trace resistance and low trace inductance for all high-current power nets from PMIC to the device.

An external interface using a connector must be protected following the IEC61000-4-2 level 4 system ESD.

8.2 Power Optimizations

This section describes the necessary steps for designing a robust Power Distribution Network (PDN):

- [8.2.1, Step 1](#): PCB Stack-up
- [8.2.2, Step 2](#): Physical Placement
- [8.2.3, Step 3](#): Static Analysis
- [8.2.4, Step 4](#): Frequency Analysis

8.2.1 Step 1: PCB Stack-up

The PCB stack-up (layer assignment) is an important factor in determining the optimal performance of the power distribution system. An optimized PCB stack-up for higher power integrity performance can be achieved by following these recommendations:

- Power and ground plane pairs must be closely coupled together. The capacitance formed between the planes can decouple the power supply at high frequencies. Whenever possible, the power and ground planes must be solid to provide continuous return path for return current.
- Use a thin dielectric between the power and ground plane pair. Capacitance is inversely proportional to the separation of the plane pair. Minimizing the separation distance (the dielectric thickness) maximizes the capacitance.
- Optimize the power and ground plane pair carrying high current supplies to key component power domains as close as possible to the same surface where these components are placed (see [8-1](#)). This will help to minimize “loop inductance” encountered between supply decoupling capacitors and component supply inputs and between power and ground plane pairs.

注: 1-2oz Cu weight for power / ground plane is preferred to enable better PCB heat spreading, helping to reduce Processor junction temperatures. In addition, it is preferable to have the power / ground planes be adjacent to the PCB surface on which the Processor is mounted.

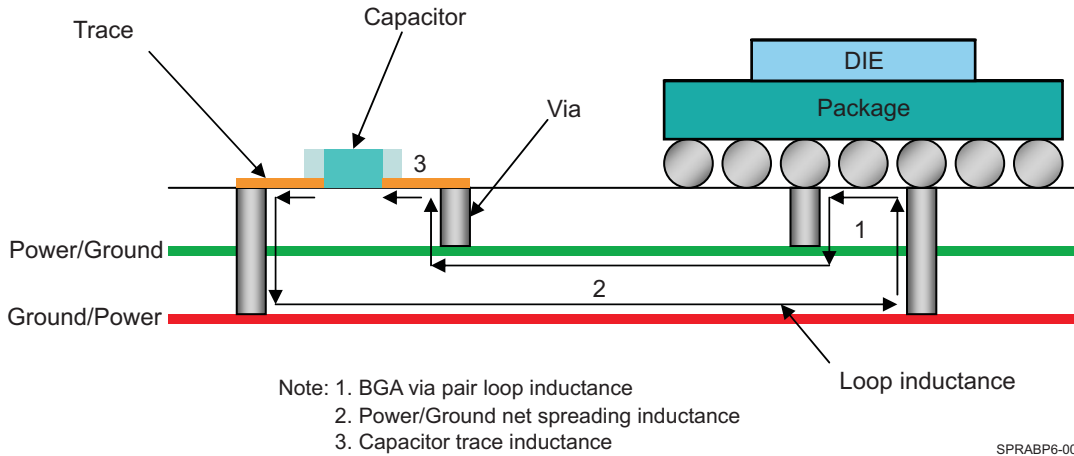

8-1. Minimize Loop Inductance With Proper Layer Assignment

The placement of power and ground planes in the PCB stackup (determined by layer assignment) has a significant impact on the parasitic inductances of power current path as shown in 8-1. For this reason, it is recommended to consider layer order in the early stages of the PCB PDN design cycle, putting high-priority supplies in the top half of the stackup (assuming high load and priority components are mounted on the top-side of PCB) and low-priority supplies in the bottom half of the stackup as shown in the examples below (vias have parasitic inductances which impact the bottom layers more, so it is advised to put the sensitive and high-priority power supplies on the top/same layers).

Two PCB stack-ups with layer assignments and via types that can enable an optimize PDN are shown in 8-2 and 8-3.

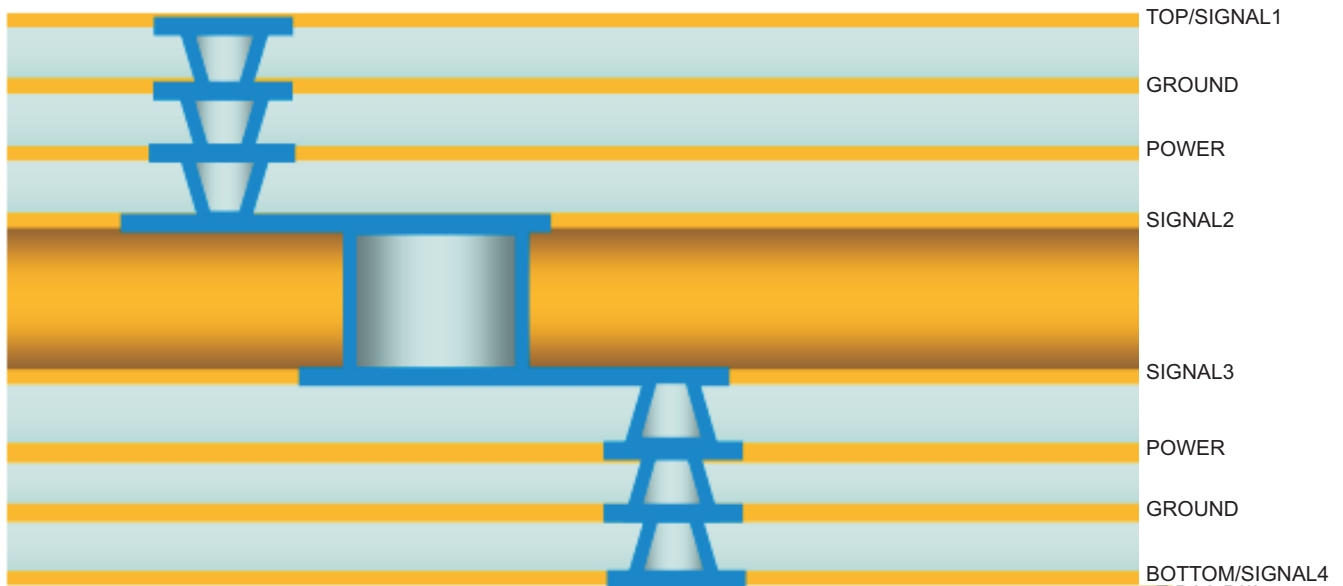

8-2. Layer PCB With High Density Interconnect (HDI) Vias

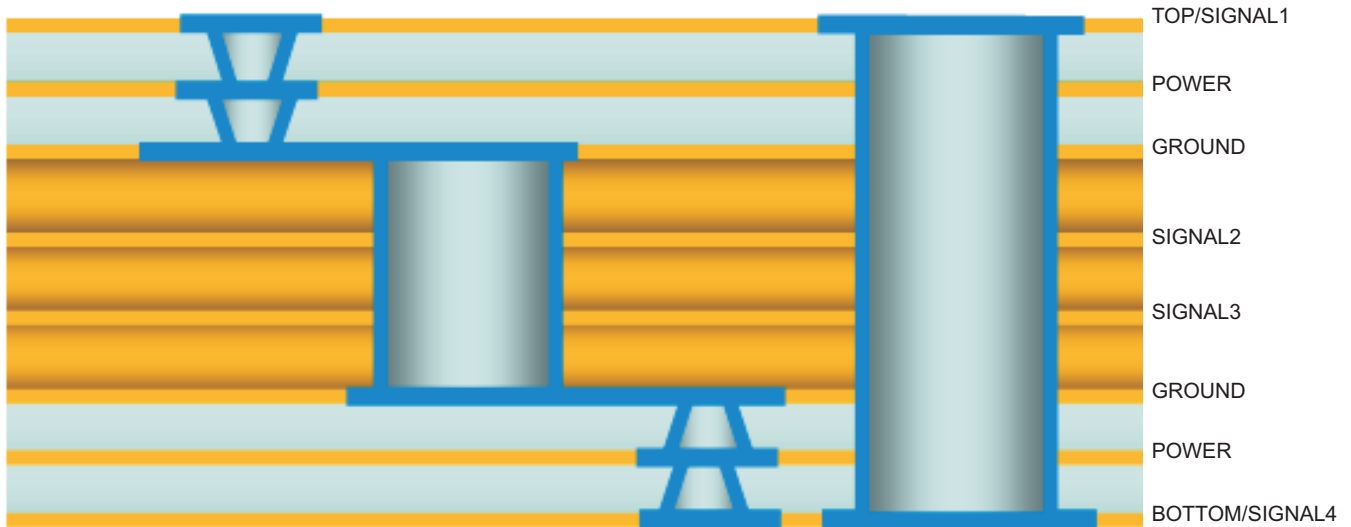

SPRABP6-003

图 8-3. Layer PCB With Plated Through Holes (PTH) Vias

8.2.2 Step 2: Physical Placement

A critical step in designing an optimized PDN is that proper care must be taken to making sure that the initial floor planning of the PCB layout is done with good power integrity design guidelines in mind. The following points are important for optimizing a PCB's PDN:

- Minimizing the physical distance between power sources and key high load components is the first step toward optimization. Placing source and load components on the same side of the PCB is desirable. This will minimize via inductance impact for high current loads and steps
- External trace routing between components must be as wide as possible. The wider the traces, the lower the DC resistance and consequently the lower the static IR drop.
- Whenever possible for the internal layers (routing and plane), wide traces and copper area fills are preferred for PDN layout. The routing of power nets in plane provide for more interplane capacitance and improved high frequency performance of the PDN.
- Whenever possible, use a via to component pin/pad ratio of 1:1 or better (i.e. especially decoupling capacitors, power inductors and current sensing resistors). Do not share vias among multiple capacitors for connecting power supply and ground planes.
- Placement of vias must be as close as possible or even within a component's solder pad if the PCB technology you are using provides this capability.

图 8-4 shows an example of acceptable width for power net routing but with poor via placement.

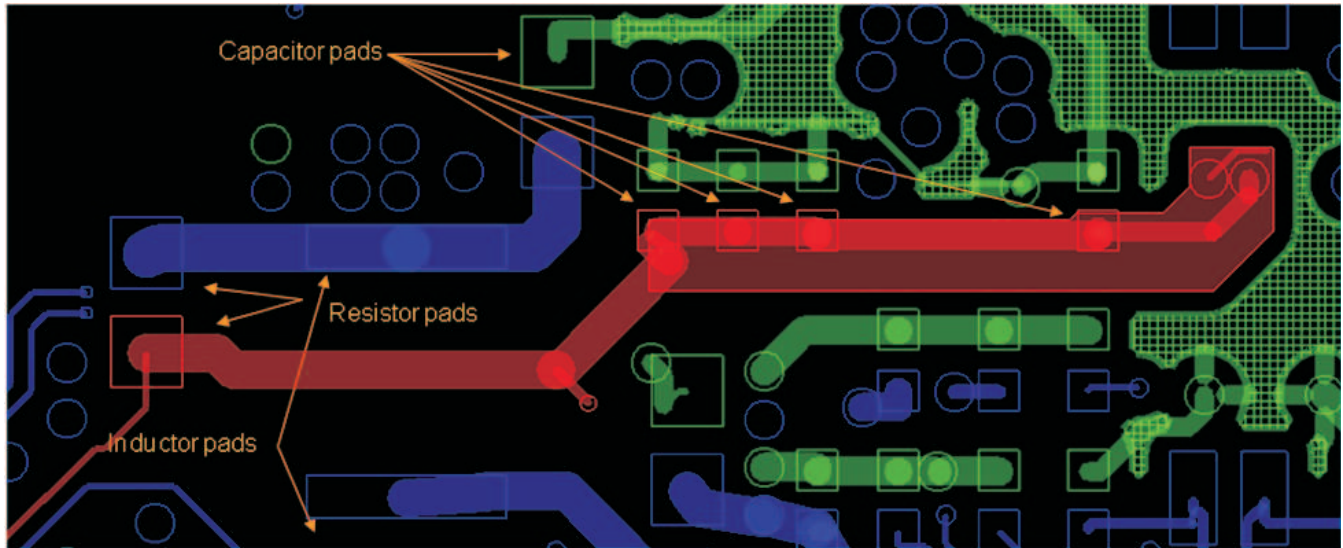

SWPS040-211

❑ 8-4. Poor Via Assignment for PDN

❑ 8-5 shows an improved power net routing with better via assignment and placement, respectively.

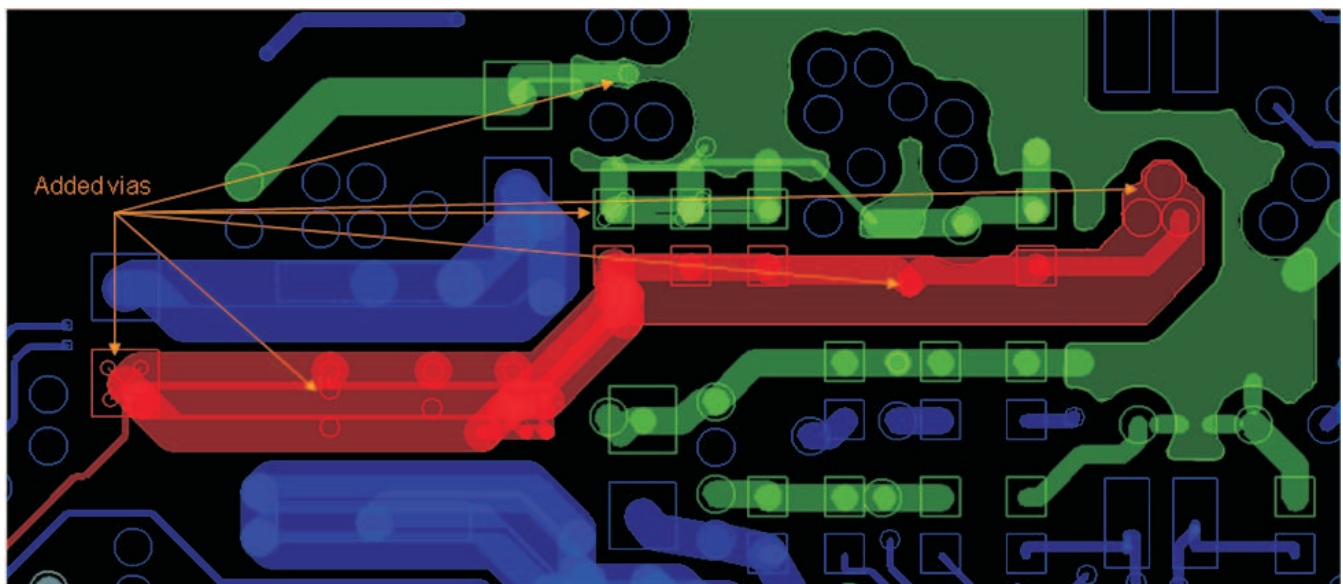

SWPS040-212

❑ 8-5. Improved Via Assignment for PDN

- To avoid any “ampacity” issue – maximum current-carrying capacity of each transitional via should be evaluated to determine the appropriate number of vias required to connect components.
❑ 8-6 and ❑ 8-7 show examples of “via starvation” on a power net transitioning from top routing layer to internal layers and the improved layout, respectively. Adding vias to bring the “via-to-pad” ratio to 1:1 will improve PDN performance.



SWPS040-213

One via for 5 capacitor pads is NOT good practice

图 8-6. Via Starvation



SWPS040-214

Added vias

图 8-7. Improved Layout With More Transitional Vias

- For noise sensitive power supplies (i.e. Phase Lock-Loops, analog signals like audio and video), a Gnd shield can be used to isolate coplanar supplies that may have high step currents or high frequency switching transitions from coupling into low-noise supplies.

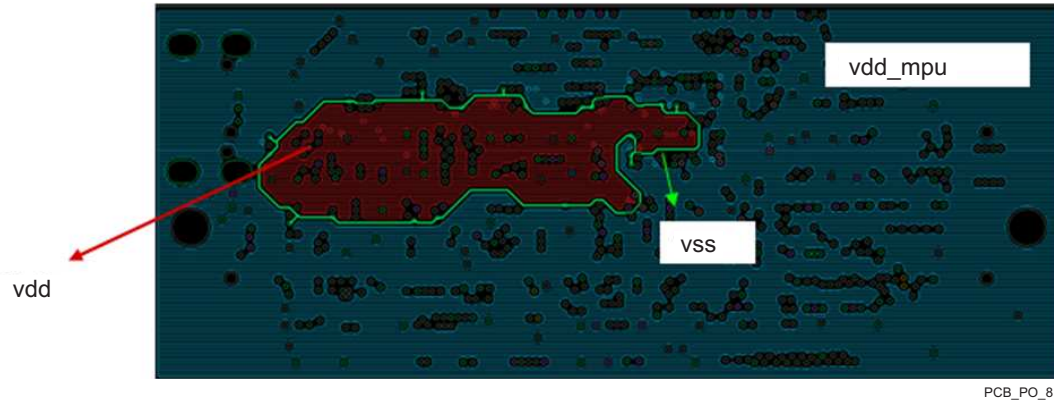

Figure 8-8. Coplanar Shielding of Power Net Using Ground Guard-band

8.2.3 Step 3: Static Analysis

Delivering reliable power to circuits is always of critical importance because voltage drops (also known as IR drops) can happen at every level within an electronic system, on-chip, within a package, and across the board. Robust system performance can only be ensured by understanding how the system elements will perform under typical stressful Use Cases. Therefore, it is a good practice to perform a Static or DC Analysis.

Static or DC analysis and design methodology results in a PDN design that minimizes voltage or IR drops across power and ground planes, traces and vias. This ensures the application processor's internal transistors will be operating within their specified voltage ranges for proper functionality. The amount of IR drop that will be encountered is based upon amount power drawn for a desired Use Case and PCB trace (widths, geometry and number of parallel traces) and via (size, type and number) characteristics.

Components that are distant from their power source are particularly susceptible to IR drop. Designs that rely on battery power must minimize voltage drops to avoid unacceptable power loss that can negatively impact system performance. Early assessments a PDN's static (DC) performance helps to determine basic power distribution parameters such as best system input power point, optimal PCB layer stackup, and copper area needed for load currents.

The resistance R_s of a plane conductor for a unit length and unit width is called the **surface resistivity** (ohms per square).

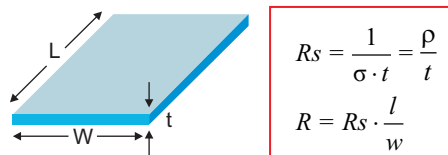

SWPS040-178

Figure 8-9. Depiction of Sheet Resistivity and Resistance

Ohm's Law ($V = I \times R$) relates conduction current to voltage drop. At DC, the relation coefficient is a constant and represents the resistance of the conductor. Even current carrying conductors will dissipate power at high currents even though their resistance may be very small. Both voltage drop and power dissipation are proportional to the resistance of the conductor.

Figure 8-10 shows a PCB-level static IR drop budget defined between the power management device (PMIC) pins and the application processor's balls when the PMIC is supplying power.

- It is highly recommended to physically place the PMIC as close as possible to the processor and on the same side. The orientation of the PMIC vs. processor should be aligned to minimize distance for the highest current rail.

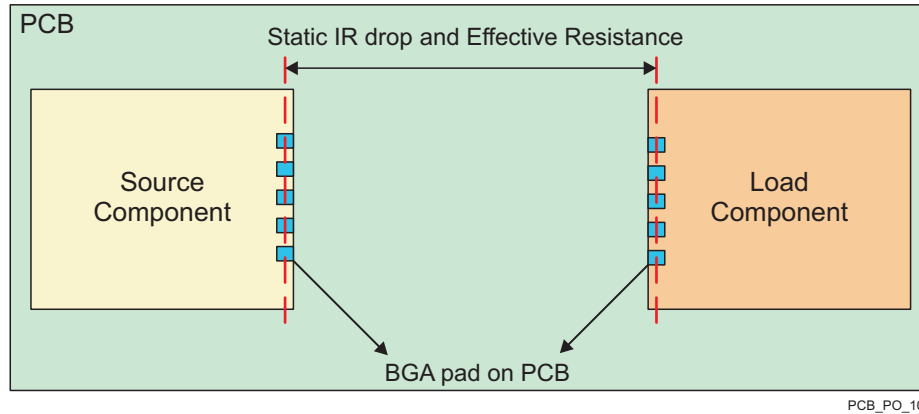

☒ 8-10. Static IR Drop Budget for PCB Only

The system-level IR drop budget is made up of three portions: on-chip, package, and PCB board. Static IR or DC analysis/design methodology consists of designing the PDN such that the voltage drop (under DC operating conditions) across power and ground pads of the transistors of the application processor device is within a specified value of the nominal voltage for proper functionality of the device.

A PCB system-level voltage drop budget for proper device functionality is typically 1.5% of nominal voltage. For a 1.35-V supply, this would be ≤ 20 mV.

To accurately analyze PCB static IR drop, the actual geometry of the PDN must be modeled properly and simulated to accurately characterize long distribution paths, copper weight impacts, electro-migration violations of current-carrying vias, and “Swiss-cheese” effects via placement has on power rails. It is recommended to perform the following analyses:

- Lumped resistance/IR drop analysis
- Distributed resistance/IR drop analysis

注: The PMIC companion device supporting Processor has been designed with voltage sensing feedback loop capabilities that enable a remote sense of the SMPS output voltage at the point of use.

The NOTE above means the SMPS feedback signals and returns must be routed across PCB and connected to the Device input power ball for which a particular SMPS is supplying power. This feedback loop provides compensation for some of the voltage drop encountered across the PDN within limits. As such, the effective resistance of the PDN within this loop should be determined in order to optimize voltage compensation loop performance. The resistance of two PDN segments are of interest: one from the power inductor/bulk power filtering capacitor node to the Processor’s input power and second is the entire PDN route from SMPS output pin/ball to the Processor input power.

In the following sections each methodology is described in detail and an example has been provided of analysis flow that can be used by the PCB designer to validate compliance to the requirements on their PCB PDN design.

8.2.3.1 PDN Resistance and IR Drop

Lumped methodology consists of grouping all of the power pins on both the PMIC (voltage source) and processor (current sink) devices. Then the PMIC source is set to an expected Use Case voltage level and the processor load has its Use Case current sink value set as well. Now the lumped/effective resistance for the power rail trace/plane routes can be determine based upon the actual layout’s power rail etch wide, shape, length, via count and placement ☒ 8-11 illustrates the pin-grouping/lumped concept.

The lumped methodology consists of importing the PCB layout database (from Cadence Allegro tool or any other layout design tool) into the static IR drop modeling and simulation tool of preference for the PCB designer. This is followed by applying the correct PCB stack-up information (thickness, material properties) of the PCB dielectric and metallization layers. The material properties of dielectric consist of permittivity (Dk) and loss tangent (Df).

For the conductor layers, the correct conductivity needs to be programmed into the simulation tool. This is followed by pin-grouping of the power and ground nets, and applying appropriate voltage/current sources. The current and voltage information can be obtained from the power and voltage specifications of the device under different operating conditions / Use Cases.



图 8-11. Pin-grouping concept: Lumped and Distributed Methodologies

8.2.4 Step 4: Frequency Analysis

Delivering low noise voltage sources are very important to allowing a system to operate at the lowest possible Operational Performance Point (OPP) for any one Use Case. An OPP is a combination of the supply voltage level and clocking rate for key internal processor domains. A SCH and PCB designed to provide low noise voltage supplies will then enable the processor to enter optimal OPPs for each Use Case that in turn will minimize power dissipation and junction temperatures on-die. Therefore, it is a good engineering practice to perform a Frequency Analysis over the key power domains.

Frequency analysis and design methodology results in a PDN design that minimizes transient noise voltages at the processor's input power balls. This allows the processor's internal transistors to operate near the minimum specified operating supply voltage levels. To accomplish this one must evaluate how a voltage supply will change due to impedance variations over frequency. This analysis will focus on the decoupling capacitor network (VDD_XXX and VSS/Gnd rails) at the load. Sufficient capacitance with a distribution of self-resonant points will provide for an overall lower impedance vs frequency response for each power domain.

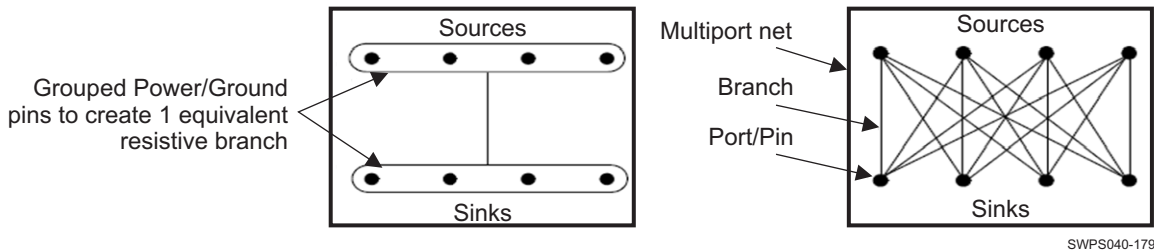
Decoupling components that are distant from their load's input power are susceptible to encountering spreading loop inductance from the PCB design. Early analysis of each key power domain's frequency response helps to determine basic decoupling capacitor placement, optimal footprint, layer assignment, and types needed for minimizing supply voltage noise/fluctuations due to switching and load current transients.

注: Evaluation of loop inductance values for decoupling capacitors placed ~300mils closer to the load's input power balls has shown an 18% reduction in loop inductance due to reduced distance.

- Decoupling capacitors must be carefully placed in order to minimize loop inductance impact on supply voltage transients. A real capacitor has characteristics not only of capacitance but also inductance and resistance.

图 8-12 shows the parasitic model of a real capacitor. A real capacitor must be treated as an RLC circuit with effective series resistance (ESR) and effective series inductance (ESL).

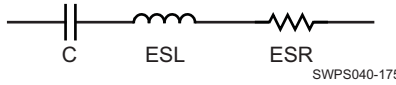

8-12. Characteristics of a Real Capacitor With ESL and ESR

The magnitude of the impedance of this series model is given as:

$$|Z| = \sqrt{ESR^2 + \left(\omega ESL - \frac{1}{\omega C}\right)^2}$$

where: $\omega = 2\pi f$

SWPS040-e002

8-13. Series Model Impedance Equation

8-14 shows the resonant frequency response of a typical capacitor with a self-resonant frequency of 55 MHz. The impedance of the capacitor is a combination of its series resistance and reactive capacitance and inductance as shown in the equation above.

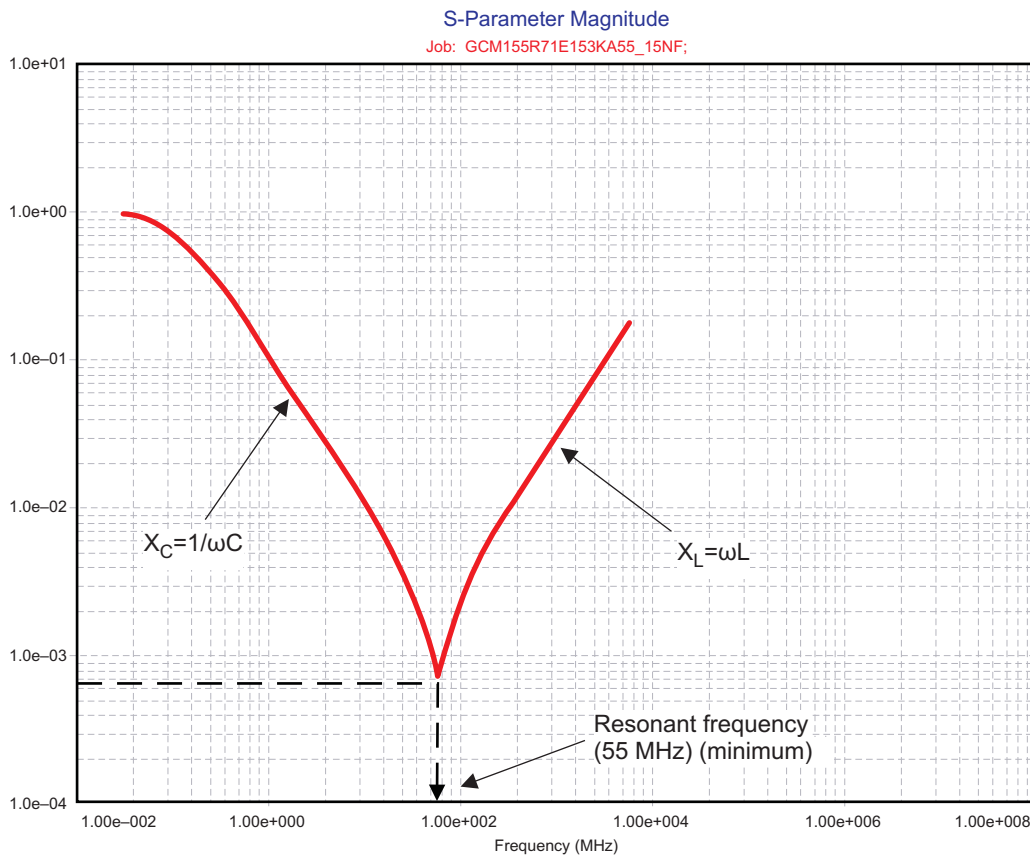

8-14. Typical Impedance Profile of a Capacitor

Because a capacitor has series inductance and resistance that impacts its effectiveness, it is important that the following recommendations are adopted in placing capacitors on the PDN.

Wherever possible, mount the capacitor with the geometry that minimizes the mounting inductance and resistance. This was shown earlier in 8-1. The capacitor mounting inductance and resistance values include the inductance and resistance of the pads, trace, and vias. Whenever possible, use footprints that have the lowest inductance configuration as shown in 8-15

The length of a trace used to connect a capacitor has a big impact on parasitic inductance and resistance of the mounting. This trace must be as short and as wide as possible. wherever possible, minimize distance to supply and Gnd vias by locating vias nearby or within the capacitor's solder pad landing. Further improvements can be made to the mounting by placing vias to the side of capacitor lands or doubling the number of vias as shown in [Figure 8-15](#). If the PCB manufacturing processes allow it and if cost-effective, via-in-pad (VIP) geometries are strongly recommended.

In addition to mounting inductance and resistance associated with placing a capacitor on the PCB, the effectiveness of a decoupling capacitor also depends on the spreading inductance and resistance that the capacitor sees with respect to the load. The spreading inductance and resistance is strongly dependent on the layer assignment in the PCB stack-up. Therefore, try to minimize X, Y and Z dimensions where the Z is due to PCB thickness (as shown in [Figure 8-2](#)).

From left (highest inductance) to right (lowest inductance) the capacitor footprint types shown in [Figure 8-15](#) are known as:

- 2-via, Skinny End Exit (2vSEE)
- 2-via, Wide End Exit (2vWEE)
- 2-via, Wide Side Exit (2vWSE)
- 4-via, Wide Side Exit (4vWSE)
- 2-via, In-Pad (2vVIP)

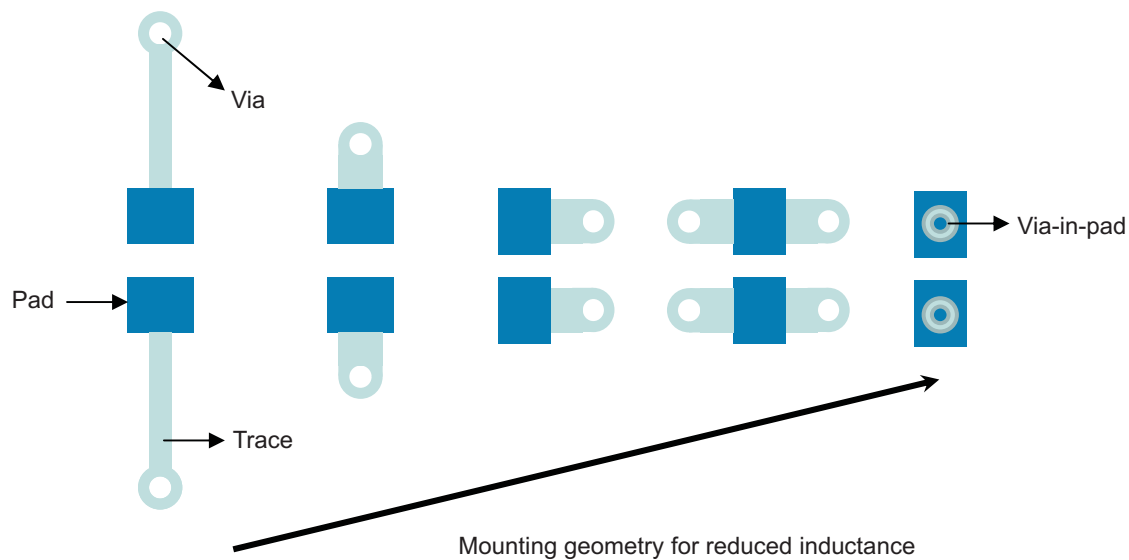

SWPS040-177

Figure 8-15. Capacitor Placement Geometry for Improved Mounting Inductance

注: Evaluation of loop inductance values for decoupling capacitor footprints 2vSEE (worst case) vs 4vWSE (2nd best) has shown a 30% reduction in inductance when 4vWSE footprint was used in place of 2vSEE.

Decoupling Capacitor (Dcap) Strategy:

1. Use lowest inductance footprint and trace connection scheme possible for given PCB technology and layout area in order to minimize Dcap loop inductance to power pin as much as possible (see [Figure 8-15](#)).
2. Place Dcaps on “same-side” as component within their power plane outline to minimize “decoupling loop inductance”. Target distance to power pin should be less than ~500mils depending upon PCB layout characteristics (plane's layer assignment and solid nature). Use PI modeling CAD tool to verify minimum inductance for top vs bottom-side placement.
3. Place Dcaps on “opposite-side” as component within their power plane outline if “same-side” is not

feasible or if distance to power pin is greater than ~500mils for top-side location. Use PI modeling CAD tool to verify minimum inductance for top vs bottom-side placement.

4. Use minimum 10mil trace width for all voltage and gnd planes connections (i.e. Dcap pads, component power pins, etc.).
5. Place all voltage and gnd plane vias “as close as possible” to point of use (i.e. Dcap pads, component power pins, etc.).
6. Use a “Power/Gnd pad/pin to via” ratio of 1:1 whenever possible. Do not exceed 2:1 ratio for small number of vias within restricted PCB areas (i.e. underneath BGA components).

Frequency analysis for the MPU power domain has yielded the vdd_mpu Impedance vs Frequency response shown in [8.3.8.2](#), vdd_mpu Example Analysis. As the example shows the overall MPU PDN R_{eff} meets the maximum recommended PDN resistance of 10m Ω .

8.2.5 System ESD Generic Guidelines

8.2.5.1 System ESD Generic PCB Guideline

Protection devices must be placed close to the ESD source which means close to the connector. This allows the device to subtract the energy associated with an ESD strike before it reaches the internal circuitry of the application board.

To help minimize the residual voltage pulse that will be built-up at the protection device due to its nonzero turn-on impedance, it is mandatory to route the ESD device with minimum stub length so that the low-resistive, low-inductive path from the signal to the ground is granted and not increasing the impedance between signal and ground.

For ESD protection array being railed to a power supply when no decoupling capacitor is available in close vicinity, consider using a decoupling capacitor ($\geq 0.1 \mu\text{F}$) tight to the VCC pin of the ESD protection. A positive strike will be partially diverted to this capacitance resulting in a lower residual voltage pulse.

Ensure that there is sufficient metallization for the supply of signals at the interconnect side (VCC and GND in [Figure 8-16](#)) from connector to external protection because the interconnect may see between 15-A to 30-A current in a short period of time during the ESD event.

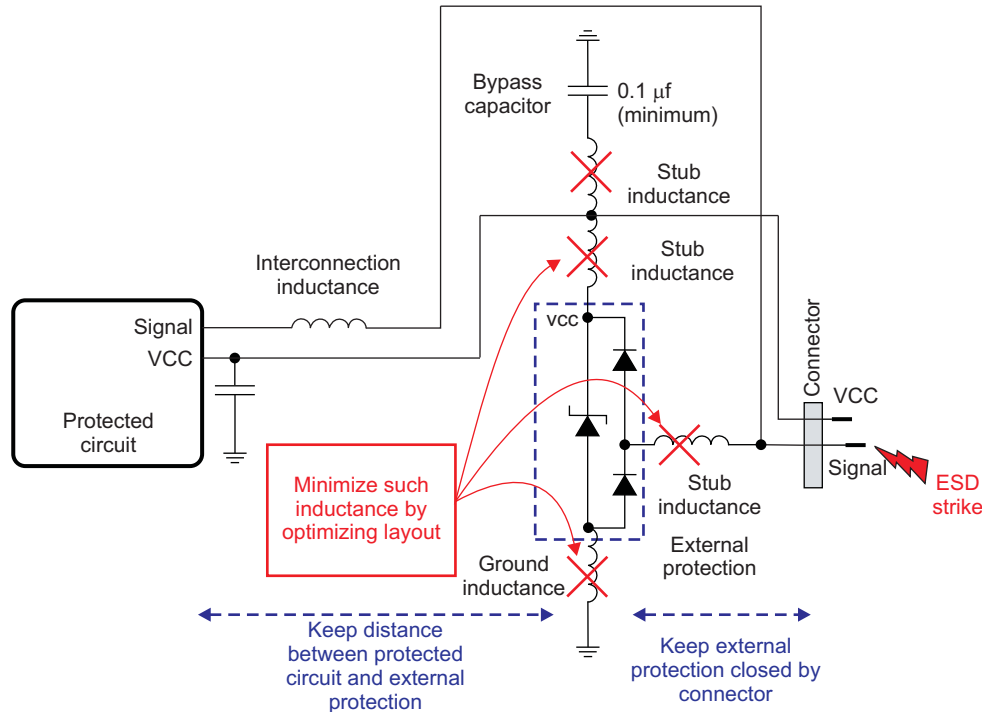

SPRABP6-004

☒ 8-16. Placement Recommendation for an ESD External Protection

注: To ensure normal behavior of the ESD protection (unwanted leakage), it is better to ground the ESD protection to the board ground rather than any local ground (example isolated shield or audio ground).

8.2.5.2 Miscellaneous EMC Guidelines to Mitigate ESD Immunity

- Avoid running critical signal traces (clocks, resets, interrupts, control signals, and so forth) near PCB edges.
- Add high frequency filtering: Decoupling capacitors close to the receivers rather than close to the drivers to minimize ESD coupling.
- Put a ground (guard) ring around the entire periphery of the PCB to act as a lightning rod.
- Connect the guard ring to the PCB ground plane to provide a low impedance path for ESD-coupled current on the ring.
- Fill unused portions of the PCB with ground plane.
- Minimize circuit loops between power and ground by using multilayer PCB with dedicated power and ground planes.
- Shield long line length (strip lines) to minimize radiated ESD.
- Avoid running traces over split ground planes. It is better to use a bridge connecting the two planes in one area.

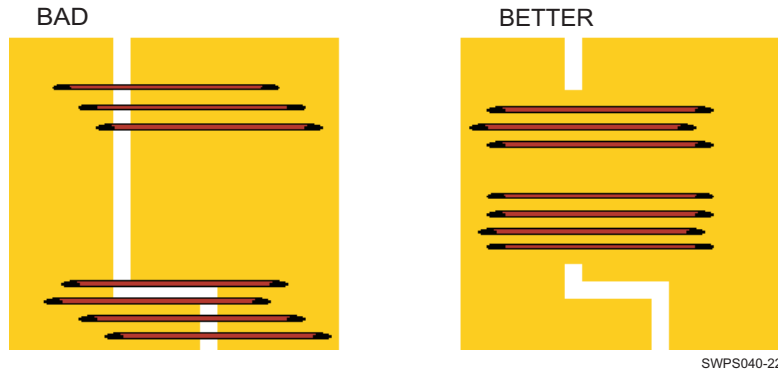

8-17. Trace Examples

- Always route signal traces and their associated ground returns as close to one another as possible to minimize the loop area enclosed by current flow:
 - At high frequencies current follows the path of least inductance.
 - At low frequencies current flows through the path of least resistance.

8.2.6 EMI / EMC Issues Prevention

All high-speed digital integrated circuits can be sources of unwanted radiation, which can affect nearby sensitive circuitry and cause the final product to have radiated emissions levels above the limits allowed by the EMC regulations if some preventative steps are not taken.

Likewise, analog and digital circuits can be susceptible to interference from the outside world and picked up by the circuitry interconnections.

To minimize the potential for EMI/EMC issues, the following guidelines are recommended to be followed.

8.2.6.1 Signal Bandwidth

To evaluate the frequency of a digital signal, an estimated rule of thumb is to consider its bandwidth f_{BW} with respect to its rise time, t_R :

$$f_{BW} \approx 0.35 / t_R$$

This frequency actually corresponds to the break point in the signal spectrum, where the harmonics start to decay at 40 dB per decade instead of 20 dB per decade.

8.2.6.2 Signal Routing

8.2.6.2.1 Signal Routing—Sensitive Signals and Shielding

Keep radio frequency (RF) sensitive circuitry (like GPS receivers, GSM/WCDMA, Bluetooth/WLAN transceivers, frequency modulation (FM) radio) away from high-speed ICs (the device, power and audio manager, chargers, memories, and so forth) and ideally on the opposite side of the PCB. For improved protection it is recommended to place these emission sources in a shield can. If the shield can have a removable lid (two-piece shield), ensure there is low contact impedance between the fence and the lid. Leave some space between the lid and the components under it to limit the high-frequency currents induced in the lid. Limit the shield size to put any potential shield resonances above the frequencies of interest; see [8-14](#), *Typical Impedance Profile of a Capacitor*.

8.2.6.2.2 Signal Routing—Outer Layer Routing

In case there is a need to use the outer layers for routing outside of shielded areas, it is recommended to route only static signals and ensure that these static signals do not carry any high-frequency components (due to parasitic coupling with other signals). In case of long traces, make provision for a bypass capacitor near the signal source.

Routing of high-frequency clock signals on outer layers, even for a short distance, is discouraged, because their emissions energy is concentrated at the discrete harmonics and can become significant even with poor radiators.

Coplanar shielding of traces on outer layers (placing ground near the sides of a track along its length) is effective only if the distance between the trace sides and the ground is smaller than the trace height above the ground reference plane. For modern multilayer PCBs this is often not possible, so coplanar shielding will not be effective. Do not route high-frequency traces near the periphery of the PCB, as the lack of a ground reference near the trace edges can increase EMI: see [8.2.6.3, Ground Guidelines](#).

8.2.6.3 Ground Guidelines

8.2.6.3.1 PCB Outer Layers

Ideally the areas on the top and bottom layers of the PCB that are not enclosed by a shield should be filled with ground after the routing is completed and connected with an adequate number of vias to the ground on the inner ground planes.

8.2.6.3.2 Metallic Frames

Ensure that all metallic parts are well connected to the PCB ground (like LCD screens metallic frames, antennas reference planes, connector cages, flex cables grounds, and so forth). If using flex PCB ribbon cables to bring high-frequency signals off the PCB, ensure they are adequately shielded (coaxial cables or flex ribbons with a solid reference ground).

8.2.6.3.3 Connectors

For high-frequency signals going to connectors choose a fully shielded connector, if possible (for example, SD card connectors). For signals going to external connectors or which are routed over long distances, it is recommended to reduce their bandwidth by using low-pass filters (resistor, capacitor (RC) combinations or lossy ferrite inductors). These filters will help to prevent emissions from the board and can also improve the immunity from external disturbances.

8.2.6.3.4 Guard Ring on PCB Edges

The major advantage of a multilayer PCB with ground-plane is the ground return path below each and every signal or power trace.

As shown in [Figure 8-18](#) the field lines of the signal return to PCB ground as long as an infinite ground is available.

Traces near the PCB-edges do not have this infinite ground and therefore may radiate more than the others. Thus, signals (clocks) or power traces (core power) identified to be critical must not be routed in the vicinity of PCB edges, or, if not avoidable, must be accompanied by a guard ring on the PCB edge.

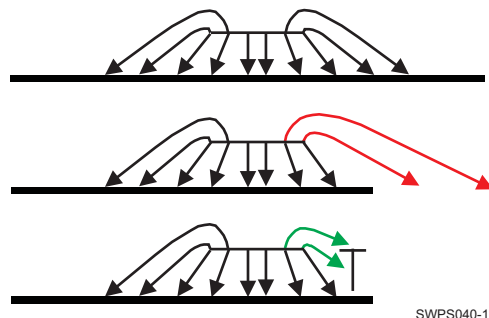

Figure 8-18. Field Lines of a Signal Above Ground

☒ 8-19. Guard Ring Routing

The intention of the guard ring is that HF-energy, that otherwise would have been emitted from the PCB edge, is reflected back into the board where it partially will be absorbed. For this purpose ground traces on the borders of all layers (including power layer) must be applied as shown in ☒ 8-19.

As these traces must have the same (HF-) potential as the ground plane they must be connected to the ground plane at least every 10 mm.

8.2.6.3.5 Analog and Digital Ground

For the optimum solution, the AGND and the DGND planes must be connected together at the power supply source in a same point. This ensures that both planes are at the same potential, while the transfer of noise from the digital to the analog domain is minimized.

8.3 Core Power Domains

This section provides boundary conditions and theoretical background to be applied as a guide for optimizing a PCB design. The decoupling capacitor and PDN characteristics tables shown below give recommended capacitors and PCB parameters to be followed for schematic and PCB designs. Board designs that meet the static and dynamic PDN characteristics shown in tables below will be aligned to the expected PDN performance needed to optimize SoC performance.

8.3.1 General Constraints and Theory

- Max PCB static/DC voltage drop (IRd) budget of **1.5% of supply voltage** when using PMICs **without remote sensing** as measured from PMIC's power inductor and filter capacitor node to Processor input including any ground return losses.
- Max PCB static/DC voltage drop (IRd) budget can be relaxed to **5% of supply voltage** when using PMICs **with remote sensing at the load** as measured from PMIC's power inductor and filter capacitor node to Device's supply input including any ground return losses.
- PMIC component DM and guidelines should be referenced for the following:
 - Routing remote feedback sensing to optimize per each SMPS's implementation
 - Selecting power filtering capacitor values and PCB placement.
- Max Effective Resistance (R_{eff}) budget can range from **4 – 50mΩ** for key Device power rails not including ground returns depending upon maximum load currents and maximum DC voltage drop budget (as discussed above).
- Max Device supply input voltage difference budget of **5mV** under max current loading shall be maintained across all balls connected to a common power rail. This represents any voltage difference that may exist between a remote sense point to any power input.
- Max PCB Loop Inductance (LL) budget between Device's power inputs and local bulk and high frequency decoupling capacitors including ground returns should range from **0.4 – 2.5nH depending upon maximum transient load currents**.
- Max PCB dynamic/AC peak-to-peak transient noise voltage budgets between PMIC and Device including ground returns are as follows:
 - **+/-3% of nominal supply voltage** for frequencies below the PMIC bandwidth (typ F_{pmic} ~ 200kHz)
 - **+/-5% of nominal supply voltage** for frequencies between F_{pmic} to F_{pcb} (typ 20 – 100MHz)

- Max PCB Impedance (Z) vs Frequency (F) budget between Device's power inputs and PMIC's output power filter node including ground return is determined by applying the Frequency Domain Target Impedance Method to determine the PCB's maximum frequency of interest (Fpcb). Ideally a properly designed and decoupled PDN will exhibit smoothly increasing Z vs. F curve. There are 2 general regions of interest as can be seen in [Figure 8-20](#).
 - 1st area is from DC (0Hz) up to Fpmic (typ a few 100 kHz) where a PMIC's transient response characteristic (i.e. Switching Freq, Compensation Loop BW) dominate. A PDN's Z is typically very low due to power filtering & bulk capacitor values when PDN has very low trace resistance (i.e. good Reff performance). The goal is to maintain a smoothly increasing Z that is less than Zt1 over this low frequency range. This will ensure that a max transient current event will not cause a voltage drop more than the PMIC's current step response can support (typ 3%).
 - 2nd area is from Fpmic up to Fpcb (typ 20-100MHz) where a PCB's inherent characteristics (i.e. parasitic capacitance, planar spreading inductances) dominate. A PDN's Z will naturally increase with frequency. At frequencies between Fpmic up to Fpcb, the goal is to maintain a smoothly increasing Z to be less than Zt2. This will ensure that the high frequency content of a max transient current event will not cause a voltage drop to be more than 5% of the min supply voltage.

$$Z_T = \frac{\text{Max Voltage Rail Drop}^{\text{Note1}}}{\text{Max Transient Current}^{\text{Note2}}}$$

$$Z_{T1} = \frac{(\text{Min Voltage}) \times (\text{PMIC's Step Response})}{(\sim 50\% \text{ of Max DC Current})} = \frac{V_{\text{min}} \times 3\%(\text{typ})}{I_{\text{max}} \times \sim 50\%}$$

$$Z_{T2} = \frac{(\text{Min Voltage}) \times (\text{High-Freq Transient Noise})}{(\sim 50\% \text{ of Max DC Current})} = \frac{V_{\text{min}} \times 5\%(\text{typ})}{I_{\text{max}} \times \sim 50\%}$$

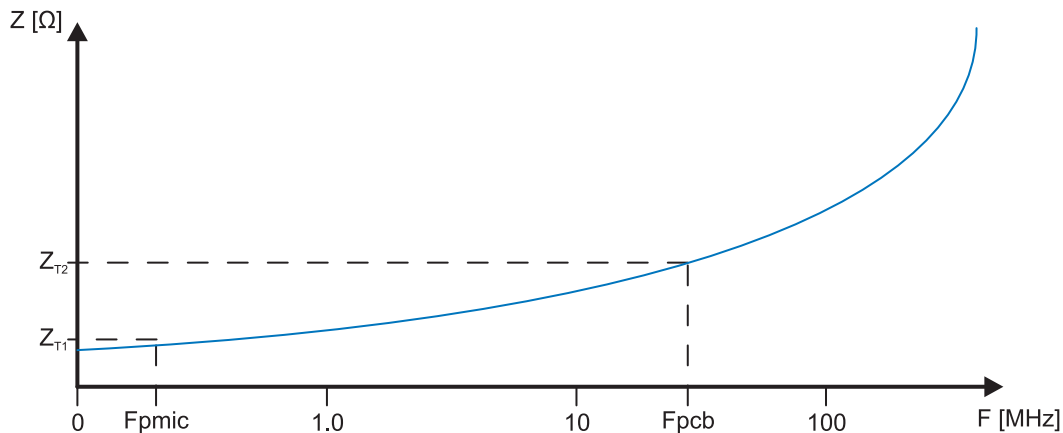

PCB_CPD_8

Figure 8-20. PDN's Target impedance

1. Voltage Rail Drop includes regulation accuracy, voltage distribution drops, and all dynamic events such as transient noise, AC ripple, voltage dips etc.

2. Typical max transient current is defined as 50% of max current draw possible.

8.3.2 Voltage Decoupling

Recommended power supply decoupling capacitors main characteristics for commercial products whose ambient temperature is not to exceed +85C are shown in table below:

表 8-1. Commercial Applications Recommended Decoupling Capacitors Characteristics⁽¹⁾⁽²⁾⁽³⁾

Value	Voltage [V]	Package	Stability	Dielectric	Capacitance Tolerance	Temp Range [°C]	Temp Sensitivity [%]	REFERENCE
22μF	6,3	0603	Class 2	X5R	- / + 20%	-55 to + 85	- / + 15	GRM188R60J226MEA0L
10μF	4,0	0402	Class 2	X5R	- / + 20%	-55 to + 85	- / + 15	GRM155R60G106ME44
4.7μF	6,3	0402	Class 2	X5R	- / + 20%	-55 to + 85	- / + 15	GRM155R60J475ME95
2.2μF	6,3	0402	Class 2	X5R	- / + 20%	-55 to + 85	- / + 15	GRM155R60J225ME95
1μF	6,3	0201	Class 2	X5R	- / + 20%	-55 to + 85	- / + 15	GRM033R60J105MEA2
470nF	6,3	0201	Class 2	X5R	- / + 20%	-55 to + 85	- / + 15	GRM033R60G474ME90
220nF	6,3	0201	Class 2	X5R	- / + 20%	-55 to + 85	- / + 15	GRM033R60J224ME90
100nF	6,3	0201	Class 2	X5R	- / + 20%	-55 to + 85	- / + 15	GRM033R60J104ME19

(1) Minimum value for each PCB capacitor: 100 nF.

(2) Among the different capacitors, 470 nF is recommended (not required) to filter at 5-MHz to 10-MHz frequency range.

(3) In comparison with the EIA Class 1 dielectrics, Class 2 dielectric capacitors tend to have severe temperature drift, high dependence of capacitance on applied voltage, high voltage coefficient of dissipation factor, high frequency coefficient of dissipation, and problems with aging due to gradual change of crystal structure. Aging causes gradual exponential loss of capacitance and decrease of dissipation factor.

Recommended power supply decoupling capacitors main characteristics for automotive products are shown in table below:

表 8-2. Automotive Applications Recommended Decoupling Capacitors Characteristics⁽¹⁾⁽²⁾

Value	Voltage [V]	Package	Stability	Dielectric	Capacitance Tolerance	Temp Range [°C]	Temp Sensitivity [%]	REFERENCE
22μF	6,3	1206	Class 2	X7R	- / + 20%	-55 to + 125	- / + 15	GCM31CR70J226ME23
10μF	6,3	0805	Class 2	X7R	- / + 20%	-55 to + 125	- / + 15	GCM21BR70J106ME22
4.7μF	10	0805	Class 2	X7R	- / + 20%	-55 to + 125	- / + 15	GCM21BC71A475MA73
2.2μF	6,3	0603	Class 2	X7R	- / + 20%	-55 to + 125	- / + 15	GCM188R70J225ME22
1μF	16	0603	Class 2	X7R	- / + 20%	-55 to + 125	- / + 15	GCM188R71C105MA64
470nF	16	0603	Class 2	X7R	- / + 20%	-55 to + 125	- / + 15	GCM188R71C474MA55
220nF	25	0603	Class 2	X7R	- / + 20%	-55 to + 125	- / + 15	GCM188L81C224MA37
100nF	16	0402	Class 2	X7R	- / + 20%	-55 to + 125	- / + 15	GCM155R71C104MA55

(1) Minimum value for each PCB capacitor: 100 nF.

(2) Among the different capacitors, 470 nF is recommended (not required) to filter at 5-MHz to 10-MHz frequency range.

8.3.3 Static PDN Analysis

One power net parameter derived from a PCB's PDN static analysis is the Effective Resistance (R_{eff}). This is the total PCB power net routing resistance that is the sum of all the individual power net segments used to deliver a supply voltage to the point of load and includes any series resistive elements (i.e. current sensing resistor) that may be installed between the PMIC outputs and Processor inputs.

8.3.4 Dynamic PDN Analysis

Three power net parameters derived from a PCB's PDN dynamic analysis are the Loop Inductance (LL), Impedance (Z) and PCB Frequency of Interest (F_{pcb}).

- LL values shown are the recommended max PCB trace inductance between a decoupling capacitor's power supply and ground reference terminals when viewed from the decoupling capacitor with a "theoretical shorted" applied across the Processor's supply inputs to ground reference.
- Z values shown are the recommended max PCB trace impedances allowed between Fpmic up to Fpcb frequency range that limits transient noise drops to no more than 5% of min supply voltage during max transient current events.
- Fpcb (Frequency of Interest) is defined to be a power rail's max frequency after which adding a reasonable number of decoupling capacitors no longer significantly reduces the power rail impedance below the desired impedance target (Zt2). This is due to the dominance of the PCB's parasitic planar spreading and internal package inductances.

表 8-3. Recommended PDN and Decoupling Characteristics (1)(2)(3)(4)(5)

PDN Analysis: Supply	Static	Dynamic			Number of Recommended Decoupling Capacitors per Supply							
	Max R _{eff} ⁽⁷⁾ [mΩ]	Dec. Cap. Max LL ⁽⁸⁾ [nH]	Impedance [mΩ]	Frequency of Interest [MHz]	100 nF ⁽⁶⁾	220 nF	470 nF	1μF	2.2 μF	4.7 μF	10 μF	22 μF
vdd_mpu	10	2	57	20	12	2	2	3	1	1		1
vdd_dspeve	13	2.5	54	20	8	1	1	2	1	1	1	
vdd	27	2	87	50	6	1	1	1	1	1		
vdd_gpu	18	2.5	207	50	6	1	1	1	1	1		
vdd_iva	48	2	800	100	5		1			1		
vdds_ddr1	10	2.5	200	100	8	4		2		2		1
vdds_ddr2	10	2.5	200	100	8	4		2		2		1
cap_vbldo_dspeve	N/A	6	N/A	N/A				1				
cap_vbldo_gpu	N/A	6	N/A	N/A				1				
cap_vbldo_iva	N/A	6	N/A	N/A				1				
cap_vbldo_mpu	N/A	6	N/A	N/A				1				
cap_vddram_core1	N/A	6	N/A	N/A				1				
cap_vddram_core2	N/A	6	N/A	N/A				1				
cap_vddram_core3	N/A	6	N/A	N/A				1				
cap_vddram_core4	N/A	6	N/A	N/A				1				
cap_vddram_core5	N/A	6	N/A	N/A				1				
cap_vddram_dspeve1	N/A	6	N/A	N/A				1				
cap_vddram_dspeve2	N/A	6	N/A	N/A				1				
cap_vddram_gpu	N/A	6	N/A	N/A				1				
cap_vddram_iva	N/A	6	N/A	N/A				1				
cap_vddram_mpu1	N/A	6	N/A	N/A				1				
cap_vddram_mpu2	N/A	6	N/A	N/A				1				

- (1) For more information on peak-to-peak noise values, see the Recommended Operating Conditions table of the Specifications chapter.
- (2) ESL must be as low as possible and must not exceed 0.5 nH.
- (3) The PDN (Power Delivery Network) impedance characteristics are defined versus the device activity (that runs at different frequency) based on the Recommended Operating Conditions table of the Specifications chapter.
- (4) The static drop requirement drives the maximum acceptable PCB resistance between the PMIC or the external SMPS and the processor power balls.
- (5) Assuming that the external SMPS (power IC) feedback sense is taken close to processor power balls.
- (6) High-frequency (30 to 70MHz) PCB decoupling capacitors
- (7) Maximum R_{eff} from SMPS to Processor.
- (8) Maximum Loop Inductance for decoupling capacitor.

注: For power IC which can support more than 10 μ F close to processor, a bulk capacitor of at least 22 μ F is strongly recommended for VDD_MPU power domains.

8.3.5 Power Supply Mapping

TPS65917 or TPS659039 are the Power Management ICs (PMICs) that should be used for the Device designs. TI requires use of these PMICs for the following reasons:

- TI has validated their use with the Device
- Board level margins including transient response and output accuracy are analyzed and optimized for the entire system
- Support for power sequencing requirements (refer to [5.9 Power Supply Sequences](#))
- Support for Adaptive Voltage Scaling (AVS) Class 0 requirements, including TI provided software

Whenever we allow for combining of rails mapped on any of the SMPSes, the PDN guidelines that are the most stringent of the rails combined should be implemented for the particular supply rail.

It is possible that some voltage domains on the device are unused in some systems. In such cases, to ensure device reliability, it is still required that the supply pins for the specific voltage domains are connected to some core power supply output.

These unused supplies though can be combined with any of the core supplies that are used (active) in the system. e.g. if IVA and GPU domains are not used, they can be combined with the CORE domain, thereby having a single power supply driving the combined CORE, IVA and GPU domains.

For the combined rail, the following relaxations do apply:

- The AVS voltage of active rail in the combined rail needs to be used to set the power supply
- The decoupling capacitance should be set according to the active rail in the combined rail

表 8-4 illustrates the approved and validated power supply connections to the Device for the SMPS outputs of the TPS659039 PMIC.

表 8-4. TPS659039 Power Supply Connections⁽¹⁾

SMPS	Valid Combination 1: Reference Platform	Valid Combination 2: MPU Centric	Valid Combination 3: DSPEVE Centric ⁽³⁾	Valid Combination 4: IVA Centric	TPS659039 Current Rating Limitation ⁽⁴⁾ ⁽⁵⁾
SMPS1/2/3 ⁽²⁾	vdd_mpu	vdd_mpu	vdd_mpu, vdd_gpu, vdd_iva	vdd_mpu	SMPS12: 6A SMPS123: 9A
SMPS3 ⁽²⁾	vdds_dds1	vdds_dds1	vdds_dds1	vdds_dds1	SMPS3: 3A
SMPS4/5	vdd_dspeve	vdd_dspeve, vdd_gpu, vdd_iva	vdd_dspeve	vdd_dspeve, vdd_gpu	SMPS45: 4A
SMPS6	vdd_gpu	vdd	vdd	vdd	SMPS6: 2-3A (BOOST_CURRENT =0/1)
SMPS7	vdd	Free	Free	Free	2A
SMPS8	vdd_iva	Free	Free	vdd_iva	1A
SMPS9	vdds18v	vdds18v	vdds18v	vdds18v	1A

(1) Power consumption is highly application-specific. Separate analysis must be performed to ensure output current ratings (average and peak) is within the limits of the PMIC for all rails of the device

(2) Dual phase (SMPS1/2) can be used as long as the peak power consumption is maintained below the SMPS1/2 capacity

a. For the latest rated output current specifications for the TPS659039 device, please refer to the PMIC data manual.

b. MPU power consumption is highly system dependent. A detailed power consumption estimate must be performed to confirm compatibility. Example: Single vs Dual MPU, OPP_NOM vs OPP_OD vs OPP_HIGH, TPS659039 configured with $V_I \geq 3V$ vs $V_I < 3V$, etc. Contact your TI representative for details.

(3) Combination 3 must only be used in systems where the MPU frequency is 1 GHz or lower. If greater than 1 GHz MPU is required, then the vdd_mpu domain must be powered independently.

(4) Refer to the PMIC data manual for the latest TPS659039 specifications

- (5) A product's maximum ambient temperature, thermal system design & heat spreading performance could limit the maximum power dissipation below the full PMIC capacity in order to not exceed recommended SoC max Tj

表 8-5 illustrates the approved and validated power supply connections to the Device for the SMPS outputs of the TPS65917 PMIC.

表 8-5. TPS65917 Power Supply Connections

TPS65917	Valid Combination 1:	Valid Combination 2	TPS65917 Current Rating Limitation ^{(1) (3)}
SMPS1	vdd_mpu	vdd_mpu	SMPS1: $3.5A \leq OPP_NOM$ (dual or single) OR $\leq OPP_OD$ (single ONLY)
SMPS2 ⁽²⁾	vdd_dspeve, vdd_gpu, vdd_iva	vdd	3.5A
SMPS3 ⁽²⁾	vdd	vdd_dspeve, vdd_gpu, vdd_iva	3A
SMPS4 ⁽³⁾	vdds18v	vdds18v	1.5A
SMPS5 ⁽⁴⁾	vdds_ddr1	vdds_ddr1	2A

- (1) Refer to the TPS65917 Data Manual for exact current rating limitations, including assumed V_{IN} and other parameters. Values provided in this table are for comparison purposes.
- (2) DSP, EVE, GPU, and IVAHD power consumption is highly application-specific. Separate analysis must be performed to ensure output current ratings (average and peak) is within the limits of the PMIC. VDD only supports OPP_NOM.
- (3) Highly application-specific. Separate analysis must be performed to ensure average and peak power is within the limits of the PMIC.
- (4) Furthermore, if SMPS5 is used for DDR power, both total memory + SoC power must be within the PMIC limits.

8.3.6 DPLL Voltage Requirement

The voltage input to the DPLLs has a low noise requirement. Board designs should supply these voltage inputs with a low noise LDO to ensure they are isolated from any potential digital switching noise. The TPS65917 and TPS659039 PMIC LDOLN outputs are specifically designed to meet this low noise requirement.

注: For more information about Input Voltage Sources, see 6.3 DPLLs, DLLs Specifications.

表 8-4 presents the voltage inputs that supply the DPLLs.

表 8-6. Input Voltage Power Supplies for the DPLLs

POWER SUPPLY	DPLLs
vdda_abe_per	DPLL_PER, DPLL_ABE and PER HSDIVIDER analog power supply
vdda_ddr	DPLL_DDR and DDR HSDIVIDER analog power supply
vdda_debug	DPLL_DEBUG analog power supply
vdda_dsp_eve	DPLL_DSP and DPLL_EVE analog power supply
vdda_gmac_core	DPLL_CORE and HSDIVIDER analog power supply
vdda_gpu	DPLL_GPU analog power supply
vdda_iva	DPLL_IVA analog power supply
vdda_video	DPLL_VIDEO1 and DPLL_VIDEO2 analog power supply
vdda_mpu	DPLL_MPU analog power supply
vdda_osc	not DPLL input but is required to be supplied by low noise input voltage

8.3.7 Loss of Input Power Event

A few key PDN design items needed to enable a controlled and compliant SoC power down sequence for a "Loss of Input Power" event are:

- “Loss of Input Power” early warning.
 - TI EVM and Reference Design Study SCHs and PDNs achieve this by using the First Stage Converter’s (i.e. LM536033-Q1) Power Good status output to enable and disable the Second Stage PMIC devices (i.e. TPS65917/919, LP8733, and LP8732). If a different First Stage Converter is used, care must be taken to ensure an adequate “PG_Status” or “Vbatt_Status” signal is provided that can disable Second Stage PMIC to begin a controlled and compliant SoC power down sequence. The total elapsed time from asserting “PG_Status” low until SoC’s PMIC input voltage reaches minimum level of 2.75 V should be minimum of 1.5 ms and 2 ms preferred.
- Maximize discharge time of First Stage Vout (VSYS_3V3 power rail = input voltage to SoC PMIC).
 - TI EVM and Reference Design Study SCHs and PDNs achieve this by opening an in-line load switch immediately upon “PG_Status” low assertion in order to remove the SoC’s 3.3 V IO load current from VSYS_3V3. This will extend the VSYS_3V3 power rail’s discharge time in order to maximize elapsed time for allowing SoC PMIC to execute a controlled and compliant power down sequence. Care should be taken to either disable or isolate any additional peripheral components that may be loading the VSYS_3V3 rail as well.
- Sufficient bulk decoupling capacitance on the First Stage Vout (VSYS_3V3 per PDN) that allows for desired 1.5 – 2 ms elapsed time as described above.
 - TI EVM and Reference Design Study SCHs and PDNs achieve this by using 200 μ F of total capacitance on VSYS_3V3. The First Stage Converter (i.e. LM536033-Q1) can typically drive a max of 400 μ F to help extend VSYS_3V3 discharge time for a compliant SoC power down sequence.
- Optimizing the Second Stage SoC PMIC’s OTP settings that determines SoC power up and down sequences and total elapsed time needed for a controlled sequence.
 - TI EVM and Reference Design Study SCHs and PDNs achieve this by using optimized OTPs per the SCH and components used. The definition of these OTPs is captured in the detailed timing diagrams for both power up and down sequences. The PDN diagram typically shows a recommended PMIC OTP ID based upon the SoC and DDR memory types.

8.3.8 Example PCB Design

The following sections describe an example PCB design and its resulting PDN performance for the vdd_mpu key processor power domain.

8.3.8.1 Example Stack-up

Layer Assignments:

- Layer Top: Signal and Segmented Power Plane
 - Processor and PMIC components placed on Top-side
- Layer 2: Gnd Plane1
- Layer 3: Signals
- Layer n: Power Plane1
- Layer n+1: Power Plane 2
- Layer n+2: Signal
- Layer n+3: Gnd Plane2
- Layer Bottom: Signal and Segmented Power Planes
 - Decoupling caps, etc.

Via Technology: Through-hole

Copper Weight:

- ½ oz for all signal layers.
- 1-2oz for all power plane for improved PCB heat spreading.
- Total PCB Thickness 0.080inches.

8.3.8.2 vdd_mpu Example Analysis

Maximum acceptable PCB resistance (R_{eff}) between the PMIC and Processor input power balls should not exceed 10m Ω .

Maximum decoupling capacitance loop inductance (LL) between Processor input power balls and decoupling capacitances should not exceed 2.0nH (ESL NOT included)

Impedance target for key frequency of interest between Processor input power balls and PMIC's SMPS output power balls should not exceed 57m Ω at 20MHz.

表 8-7. Example PCB vdd_mpu PI Analysis Summary

Parameter	Recommendation	Example PCB
Processor OPP	High	
Clocking Rate	1.5 GHz	
Voltage Level	1.22V	1.22V
Max Current Draw	5.12 A	5.12 A
Max Effective Resistance: Power Inductor Segment Total R_{eff}	10m Ω	9.0m Ω
Max Loop Inductance	2.0nH	1.0 – 1.4nH
Impedance Target	57m Ω F<20Mhz	57m Ω F<20Mhz

☒ 8-21, ☒ 8-22, ☒ 8-23, and ☒ 8-24 show a PCB layout example and the resulting PI analysis results.

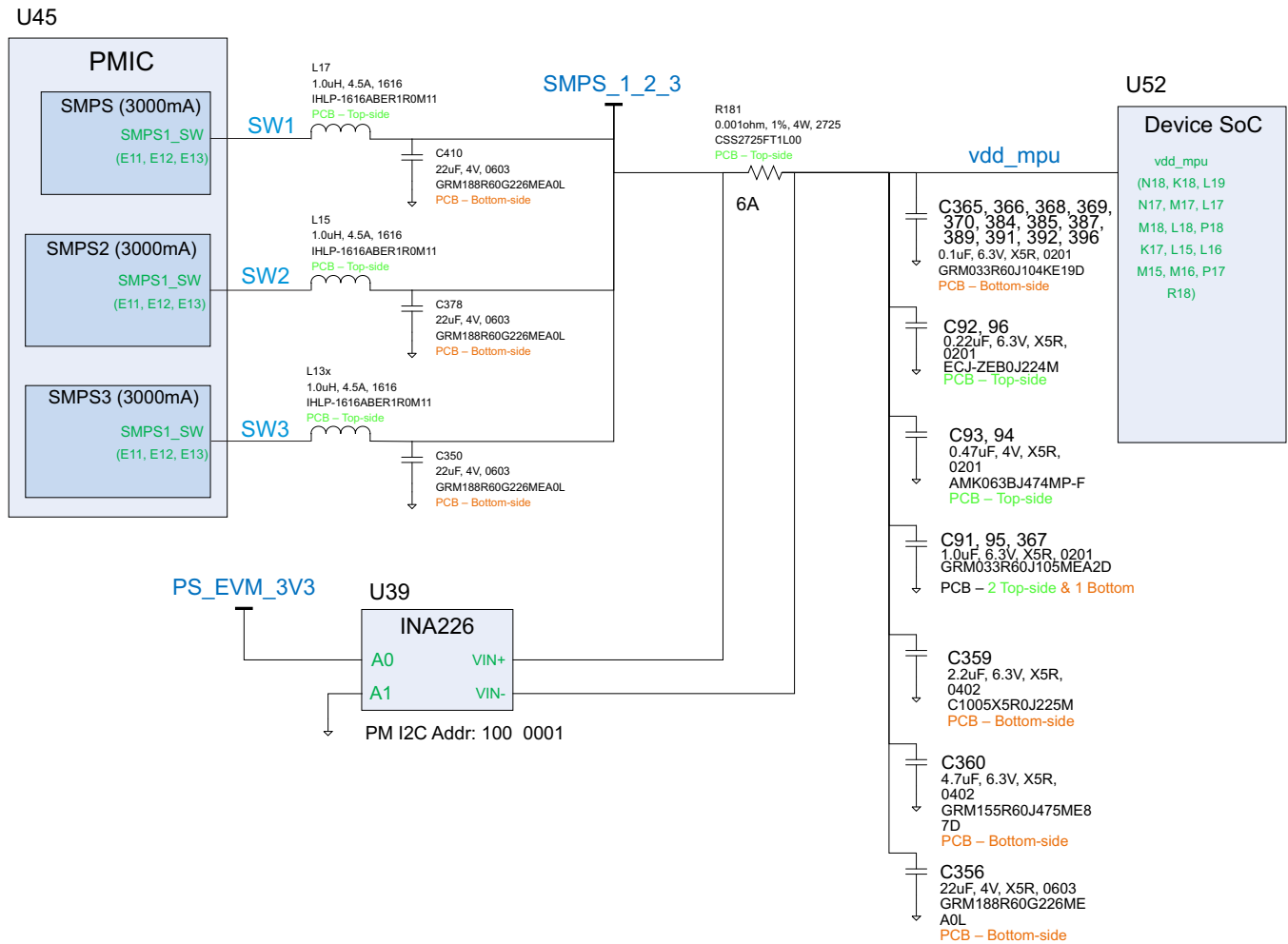

☒ 8-21. vdd_mpu Simplified SCH Diagram

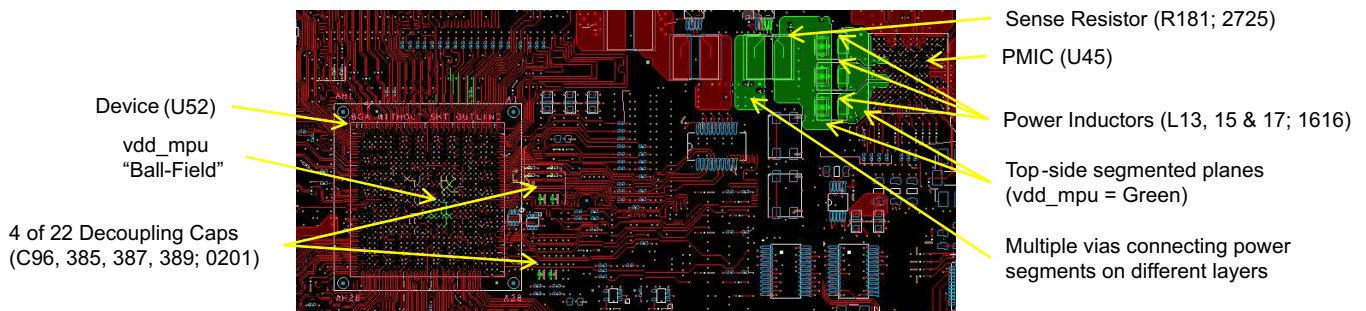

☒ 8-22. vdd_mpu routing [Top Layer]



图 8-23. vdd_mpu routing [Internal Power Plane #2]



图 8-24. vdd_mpu routing and cap placements [Bottom Layer]

表 8-8. PCB Etch Resistance Breakdown - From PMIC Source to Device Load

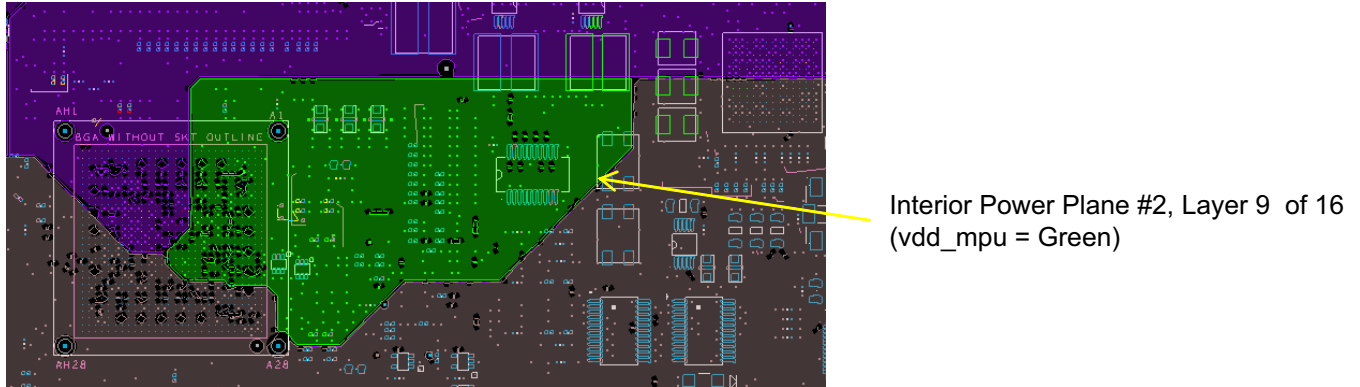
Net[from]	Component [from]:	Net[to]	Component [to]:	Etch Resistance (Ω)	% of Total Etch Resistance
SW1	L17	SW1	U45	0,001038	13%
SW2	L15	SW2	U45	0,000898	12%
SW3	L13	SW3	U45	0,000861	11%
SW1	L17	SMPS_1_2_3	R181	0,000696	9%
SW2	L15	SMPS_1_2_3	R181	0,000541	7%
SW3	L13	SMPS_1_2_3	R181	0,000526	7%
vdd_mpu	R181	vdd_mpu	U52	0,006311	78%
vdd_mpu	R181	vdd_mpu	U52	0,006311	81%
vdd_mpu	R181	vdd_mpu	U52	0,006311	82%
Total Etch Resistance from SW1 =				0,008045	100%
Total Etch Resistance from SW2 =				0,00775	100%
Total Etch Resistance from SW3 =				0,007698	100%
Max Value =				0,008045	

表 8-9. PCB Etch Resistance Breakdown - From Power Inductor to Device Load

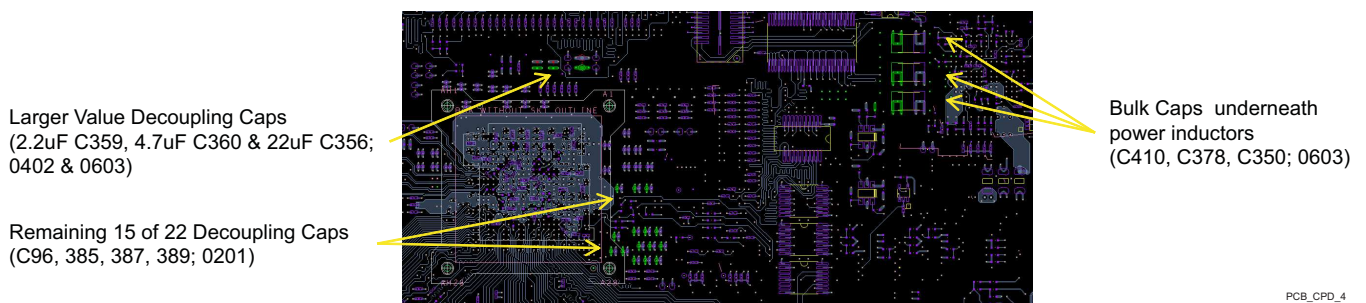
Net[from]	Component [from]:	Net[to]	Component [to]:	Etch Resistance (Ω)	% of Total Etch Resistance
SMPS_1_2_3	L17	SMPS_1_2_3	R181	0,000696	10%
SMPS_1_2_3	L15	SMPS_1_2_3	R181	0,000541	8%
SMPS_1_2_3	L13	SMPS_1_2_3	R181	0,000526	8%

表 8-9. PCB Etch Resistance Breakdown - From Power Inductor to Device Load (continued)

Net[from]	Component [from]:	Net[to]	Component [to]:	Etch Resistance (Ω)	% of Total Etch Resistance
vdd_mpu	R181	vdd_mpu	U52	0,006311	90%
vdd_mpu	R181	vdd_mpu	U52	0,006311	92%
vdd_mpu	R181	vdd_mpu	U52	0,006311	92%
Total Etch Resistance =				0,007007	100%
Total Etch Resistance =				0,006852	100%
Total Etch Resistance =				0,006837	100%
Max Value =				0,007007	

表 8-10. PDN Effective Resistance - From PMIC Source to Device Load

PDN Elements	PDN Effective Resistance (Ω)	% of Total Etch Resistance
Etch	0,008045	89%
Inductor	0	0%
Sense Resistor	0,001	11%
Max PDN Effectiv Resistance from Source	0,009045	100%

IR Drop: vdd_mpu (PCB RevJan14, Sentinel PSI)

- Source Conditions: 1.22V @ 5,12A
- Recommended $R_{eff} < 10m\Omega$
- $R_{eff} = \text{Total Trace Resistance} + \text{Sence Resistor} = 8,04m\Omega + 1m\Omega = 9,04m\Omega$
- Voltage / IR Drop: 1,22 - 1,179 = 52,6 mV



图 8-25. vdd_mpu Voltage/IR Drop [All Layers]

Dynamic analysis of this PCB design for the MPU power domain determined the vdd_mpu decoupling capacitor loop inductance and impedance vs frequency analysis shown below. As you can see, the loop inductance values ranged from 1.0 to 1.4nH and were less than maximum 2.0nH recommended.

注: Comparing loop inductances for capacitors at different distances from the processor's input power balls shows an 18% reduction for caps placed closer. This was derived by averaging the inductances for the 3 caps with distances over 800mils (Avg LL = 1.33nH) vs the 3 caps with distances less than 600mils (Avg LL = 1.096nH).

表 8-11. Rail - vdd_mpu

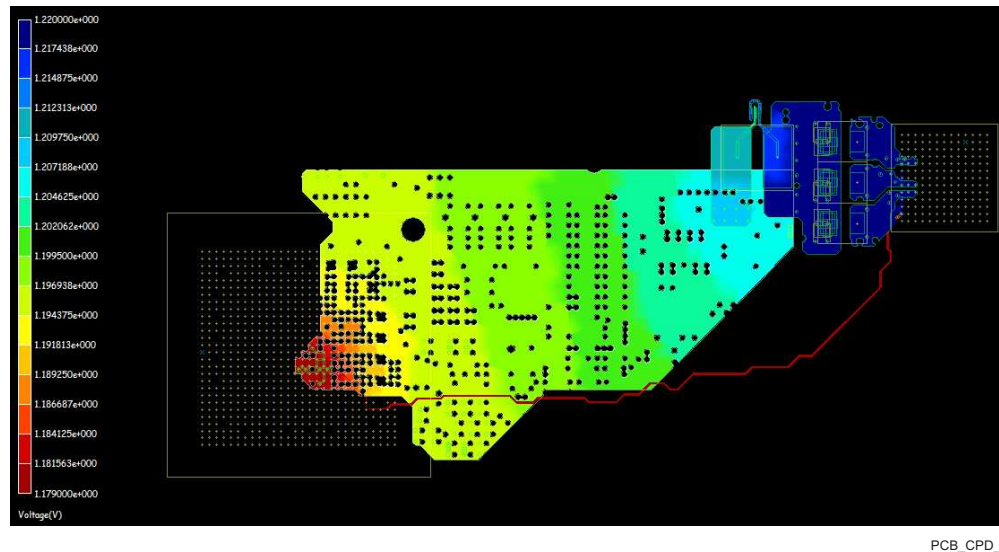
Cap Ref Des	Model Port #	Loop Inductance [nH]	Footprint Types	PCB Side	Distance to Ball-Field [mils]	Value [μ F]	Size
C356	1	1,4	4vWSE	Bottom	897	22	0603
C359	2	1,26	4vWSE	Bottom	855	2,2	0402
C360	3	1,33	4vWSE	Bottom	850	4,7	0402
C365	4	1,14	4vWSE	Bottom	817	0,1	0201
C366	5	1,13	4vWSE	Bottom	755	0,1	0201
C367	6	1,07	4vWSE	Bottom	758	1	0201
C368	7	1,12	4vWSE	Bottom	811	0,1	0201
C369	8	1,06	4vWSE	Bottom	690	0,1	0201
C370	9	1,12	4vWSE	Bottom	680	0,1	0201
C384	10	1,04	4vWSE	Bottom	686	0,1	0201
C385	11	1,07	4vWSE	Top	686	0,1	0201
C387	12	1,16	4vWSE	Top	755	0,1	0201
C389	13	1,18	4vWSE	Top	693	0,1	0201
C391	14	1,14	4vWSE	Bottom	693	0,1	0201
C392	15	1,18	4vWSE	Bottom	542	0,1	0201
C396	16	1,11	4vWSE	Bottom	745	0,1	0201
C91	17	1,1	4vWSE	Bottom	515	1	0201
C92	18	1,09	4vWSE	Bottom	622	0,22	0201
C93	19	1,01	4vWSE	Bottom	504	0,47	0201
C94	20	1,13	4vWSE	Bottom	604	0,47	0201
C95	21	1,04	4vWSE	Bottom	612	1	0201
C96	22	1,08	4vWSE	Top	612	0,22	0201

Loop Inductance range: 1,01 - 1,40 nH

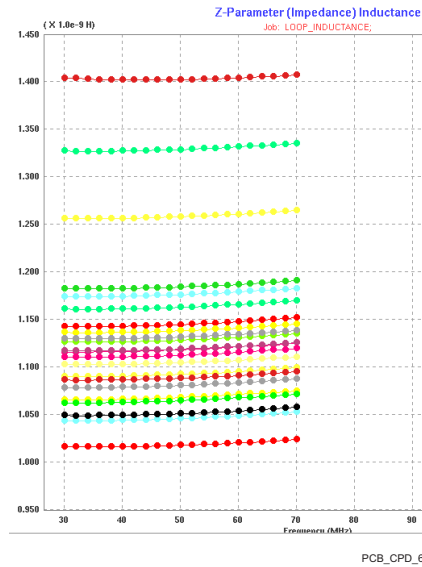

8-26. vdd_mpu Decoupling Cap Loop Inductances

8-27 shows vdd_mpu Impedance vs Frequency characteristics.

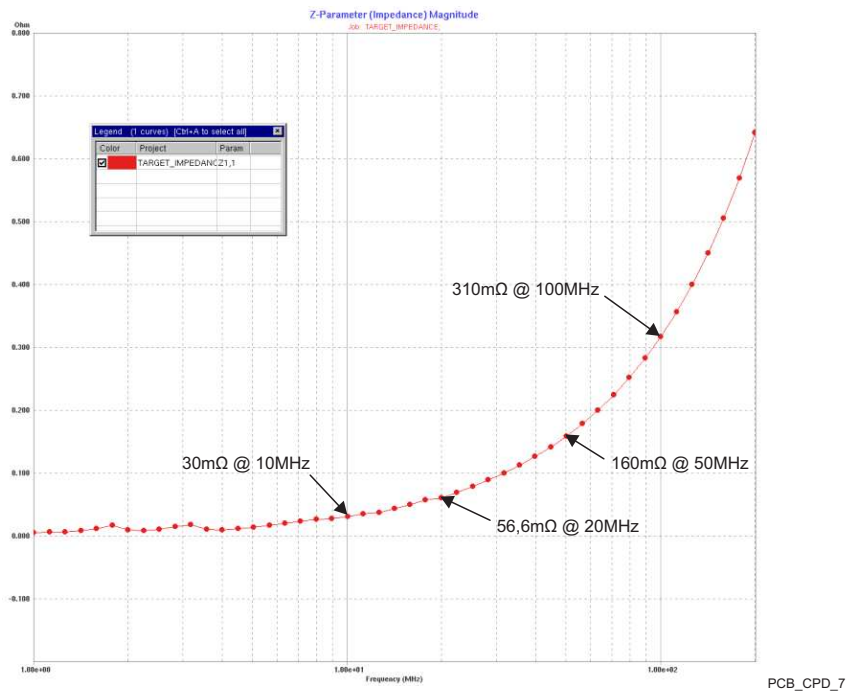

8-27. vdd_mpu Impedance vs Frequency

8.4 Single-Ended Interfaces

8.4.1 General Routing Guidelines

The following paragraphs detail the routing guidelines that must be observed when routing the various functional LVCMOS interfaces.

- Line spacing:
 - For a line width equal to W , the spacing between two lines must be $2W$, at least. This minimizes the crosstalk between switching signals between the different lines. On the PCB, this is not achievable everywhere (for example, when breaking signals out from the device package), but it is recommended to follow this rule as much as possible. When violating this guideline, minimize the length of the traces running parallel to each other (see [Figure 8-28](#)).

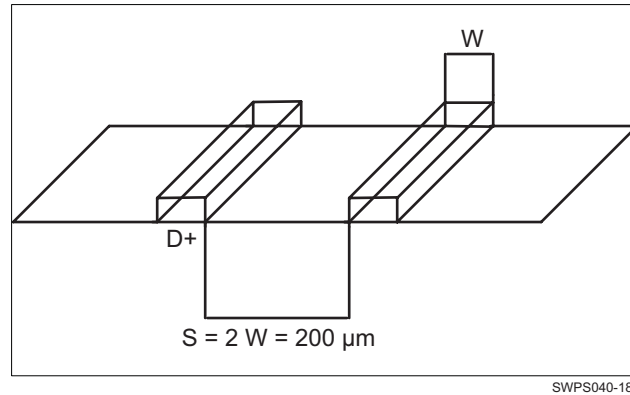

Figure 8-28. Ground Guard Illustration

- Length matching (unless otherwise specified):
 - For bus or traces at frequencies less than 10 MHz, the trace length matching (maximum length difference between the longest and the shortest lines) must be less than 25 mm.
 - For bus or traces at frequencies greater than 10 MHz, the trace length matching (maximum length difference between the longest and the shortest lines) must be less than 2.5 mm.
- Characteristic impedance
 - Unless otherwise specified, the characteristic impedance for single-ended interfaces is recommended to be between 35- Ω and 65- Ω .
- Multiple peripheral support
 - For interfaces where multiple peripherals have to be supported in the star topology, the length of each branch has to be balanced. Before closing the PCB design, it is highly recommended to verify signal integrity based on simulations including actual PCB extraction.

8.4.2 QSPI Board Design and Layout Guidelines

The following section details the routing guidelines that must be observed when routing the QSPI interfaces.

- The `qspi1_sclk` output signal must be looped back into the `qspi1_rtclk` input.
- The signal propagation delay from the `qspi1_sclk` ball to the QSPI device CLK input pin (A to C) must be approximately equal to the signal propagation delay from the QSPI device CLK pin to the `qspi1_rtclk` ball (C to D).
- The signal propagation delay from the QSPI device CLK pin to the `qspi1_rtclk` ball (C to D) must be approximately equal to the signal propagation delay of the control and data signals between the QSPI device and the SoC device (E to F, or F to E).
- The signal propagation delay from the `qspi1_sclk` signal to the series terminators ($R2 = 10 \Omega$) near the QSPI device must be $< 450\text{pS}$ ($\sim 7\text{cm}$ as stripline or $\sim 8\text{cm}$ as microstrip)
- 50 Ω PCB routing is recommended along with series terminations, as shown in [Figure 8-29](#).

- Propagation delays and matching:
 - A to C = C to D = E to F.
 - Matching skew: < 60pS
 - A to B < 450pS
 - B to C = as small as possible (<60pS)

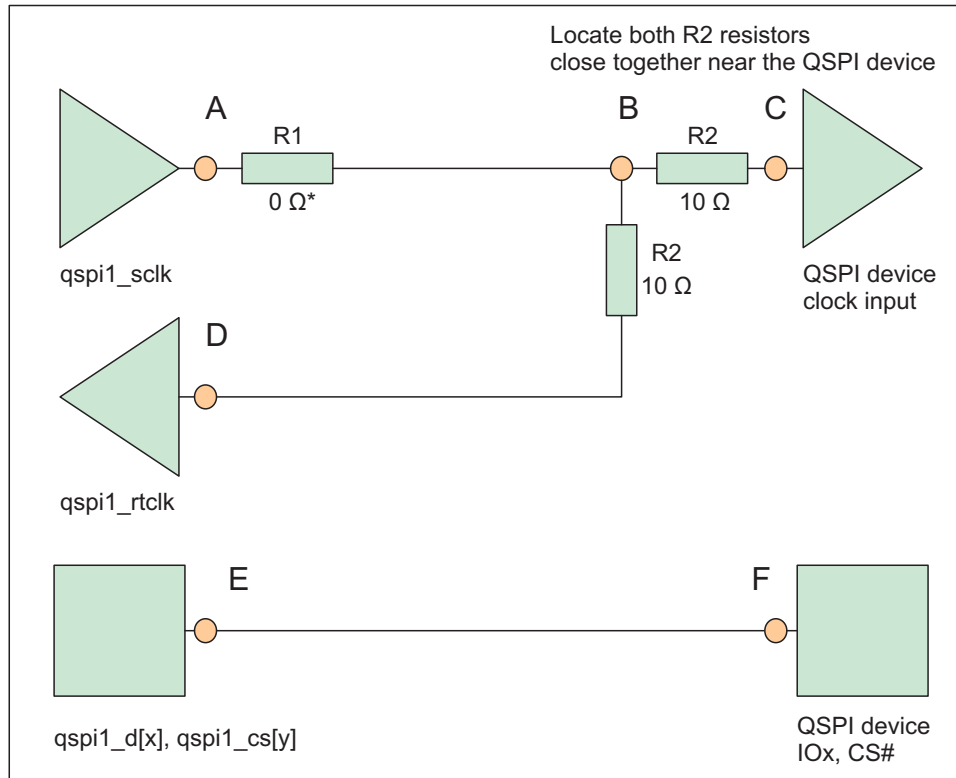

8-29. QSPI Interface High Level Schematic

(1) 0 Ω resistor (R1), located as close as possible to the qspi1_sclk pin, is placeholder for fine-tuning if needed.

8.5 Differential Interfaces

8.5.1 General Routing Guidelines

To maximize signal integrity, proper routing techniques for differential signals are important for high-speed designs. The following general routing guidelines describe the routing guidelines for differential lanes and differential signals.

- As much as possible, no other high-frequency signals must be routed in close proximity to the differential pair.
- Must be routed as differential traces on the same layer. The trace width and spacing must be chosen to yield the differential impedance value recommended.
- Minimize external components on differential lanes (like external ESD, probe points).
- Through-hole pins are not recommended.
- Differential lanes mustn't cross image planes (ground planes).
- No sharp bend on differential lanes.
- Number of vias on the differential pairs must be minimized, and identical on each line of the differential pair. In case of multiple differential lanes in the same interface, all lines should have the same number of vias.

- Shielded routing is to be promoted as much as possible (for instance, signals must be routed on internal layers that are inside power and/or ground planes).

8.5.2 USB 2.0 Board Design and Layout Guidelines

This section discusses schematic guidelines when designing a universal serial bus (USB) system.

8.5.2.1 Background

Clock frequencies generate the main source of energy in a USB design. The USB differential DP/DM pairs operate in high-speed mode at 480 Mbps. System clocks can operate at 12 MHz, 48 MHz, and 60 MHz. The USB cable can behave as a monopole antenna; take care to prevent RF currents from coupling onto the cable.

When designing a USB board, the signals of most interest are:

- Device interface signals: Clocks and other signal/data lines that run between devices on the PCB.
- Power going into and out of the cable: The USB connector socket pin 1 (VBUS) may be heavily filtered and need only pass low frequency signals of less than ~100 KHz. The USB socket pin 4 (analog ground) must be able to return the current during data transmission, and must be filtered sparingly.
- Differential twisted pair signals going out on cable, DP and DM: Depending upon the data transfer rate, these device terminals can have signals with fundamental frequencies of 240 MHz (high speed), 6 MHz (full speed), and 750 kHz (low speed).
- External crystal circuit (device terminals XI and X0): 12 MHz, 19.2 MHz, 24 MHz, and 48 MHz fundamental. When using an external crystal as a reference clock, a 24 MHz and higher crystal is highly recommended.

8.5.2.2 USB PHY Layout Guide

The following sections describe in detail the specific guidelines for USB PHY Layout.

8.5.2.2.1 General Routing and Placement

Use the following routing and placement guidelines when laying out a new design for the USB physical layer (PHY). These guidelines help minimize signal quality and electromagnetic interference (EMI) problems on a four-or-more layer evaluation module (EVM).

- Place the USB PHY and major components on the un-routed board first. For more details, see [8.5.2.2.2.3](#).
- Route the high-speed clock and high-speed USB differential signals with minimum trace lengths.
- Route the high-speed USB signals on the plane closest to the ground plane, whenever possible.
- Route the high-speed USB signals using a minimum of vias and corners. This reduces signal reflections and impedance changes.
- When it becomes necessary to turn 90°, use two 45° turns or an arc instead of making a single 90° turn. This reduces reflections on the signal traces by minimizing impedance discontinuities.
- Do not route USB traces under or near crystals, oscillators, clock signal generators, switching regulators, mounting holes, magnetic devices or IC's that use or duplicate clock signals.
- Avoid stubs on the high-speed USB signals because they cause signal reflections. If a stub is unavoidable, then the stub should be less than 200 mils.
- Route all high-speed USB signal traces over continuous planes (V_{CC} or GND), with no interruptions. Avoid crossing over anti-etch, commonly found with plane splits.

8.5.2.2.2 Specific Guidelines for USB PHY Layout

The following sections describe in detail the specific guidelines for USB PHY Layout.

8.5.2.2.2.1 Analog, PLL, and Digital Power Supply Filtering

To minimize EMI emissions, add decoupling capacitors with a ferrite bead at power supply terminals for the analog, phase-locked loop (PLL), and digital portions of the chip. Place this array as close to the chip as possible to minimize the inductance of the line and noise contributions to the system. An analog and digital supply example is shown in [Figure 8-30](#). In case of multiple power supply pins with the same function, tie them up to a single low-impedance point in the board and then add the decoupling capacitors, in addition to the ferrite bead. This array of caps and ferrite bead improve EMI and jitter performance. Take both EMI and jitter into account before altering the configuration.

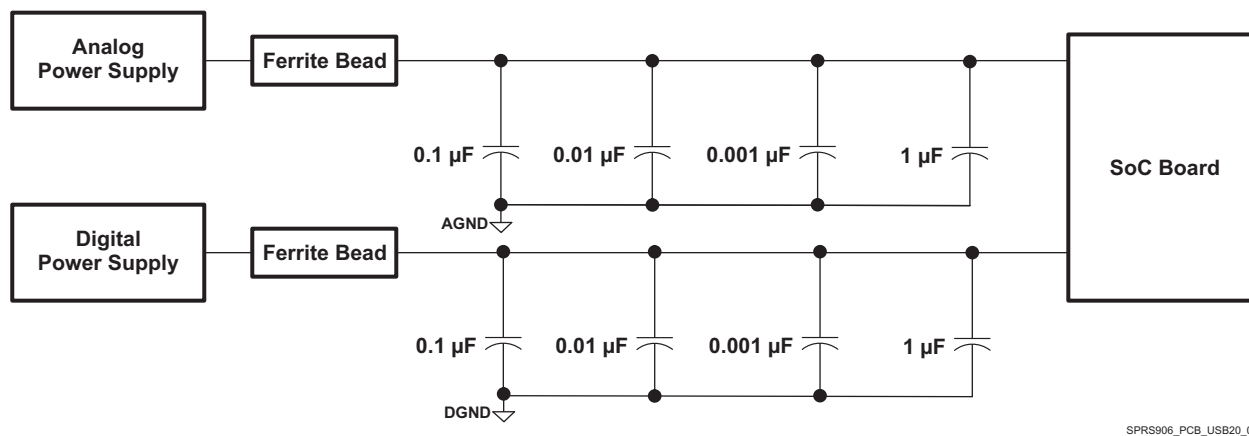

SPRS906_PCB_USB20_01

Figure 8-30. Suggested Array Capacitors and a Ferrite Bead to Minimize EMI

Consider the recommendations listed below to achieve proper ESD/EMI performance:

- Use a 0.01 μF cap on each cable power VBUS line to chassis GND close to the USB connector pin.
- Use a 0.01 μF cap on each cable ground line to chassis GND next to the USB connector pin.
- If voltage regulators are used, place a 0.01 μF cap on both input and output. This is to increase the immunity to ESD and reduce EMI. For other requirements, see the device-specific datasheet.

8.5.2.2.2.2 Analog, Digital, and PLL Partitioning

If separate power planes are used, they must be tied together at one point through a low-impedance bridge or preferably through a ferrite bead. Care must be taken to capacitively decouple each power rail close to the device. The analog ground, digital ground, and PLL ground must be tied together to the low-impedance circuit board ground plane.

8.5.2.2.2.3 Board Stackup

Because of the high frequencies associated with the USB, a printed circuit board with at least four layers is recommended; two signal layers separated by a ground and power layer as shown in [Figure 8-31](#).

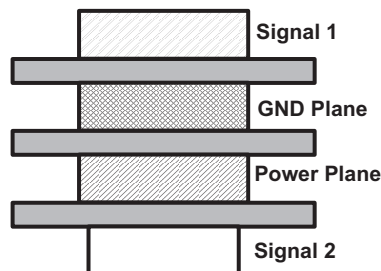

Figure 8-31. Four-Layer Board Stack-Up

The majority of signal traces should run on a single layer, preferably SIGNAL1. Immediately next to this layer should be the GND plane, which is solid with no cuts. Avoid running signal traces across a split in the ground or power plane. When running across split planes is unavoidable, sufficient decoupling must be used. Minimizing the number of signal vias reduces EMI by reducing inductance at high frequencies.

8.5.2.2.2.4 Cable Connector Socket

Short the cable connector sockets directly to a small chassis ground plane (*GND strap*) that exists immediately underneath the connector sockets. This shorts EMI (and ESD) directly to the chassis ground before it gets onto the USB cable. This etch plane should be as large as possible, but all the conductors coming off connector pins 1 through 6 must have the board signal GND plane run under. If needed, scoop out the chassis GND strap etch to allow for the signal ground to extend under the connector pins. Note that the etches coming from pins 1 and 4 (VBUS power and GND) should be wide and via-ed to their respective planes as soon as possible, respecting the filtering that may be in place between the connector pin and the plane. See [Figure 8-32](#) for a schematic example.

Place a ferrite in series with the cable shield pins near the USB connector socket to keep EMI from getting onto the cable shield. The ferrite bead between the cable shield and ground may be valued between 10 Ω and 50 Ω at 100 MHz; it should be resistive to approximately 1 GHz. To keep EMI from getting onto the cable bus power wire (a very large antenna) a ferrite may be placed in series with cable bus power, VBUS, near the USB connector pin 1. The ferrite bead between connector pin 1 and bus power may be valued between 47 Ω and approximately 1000 Ω at 100 MHz. It should continue being resistive out to approximately 1 GHz, as shown in [Figure 8-32](#).

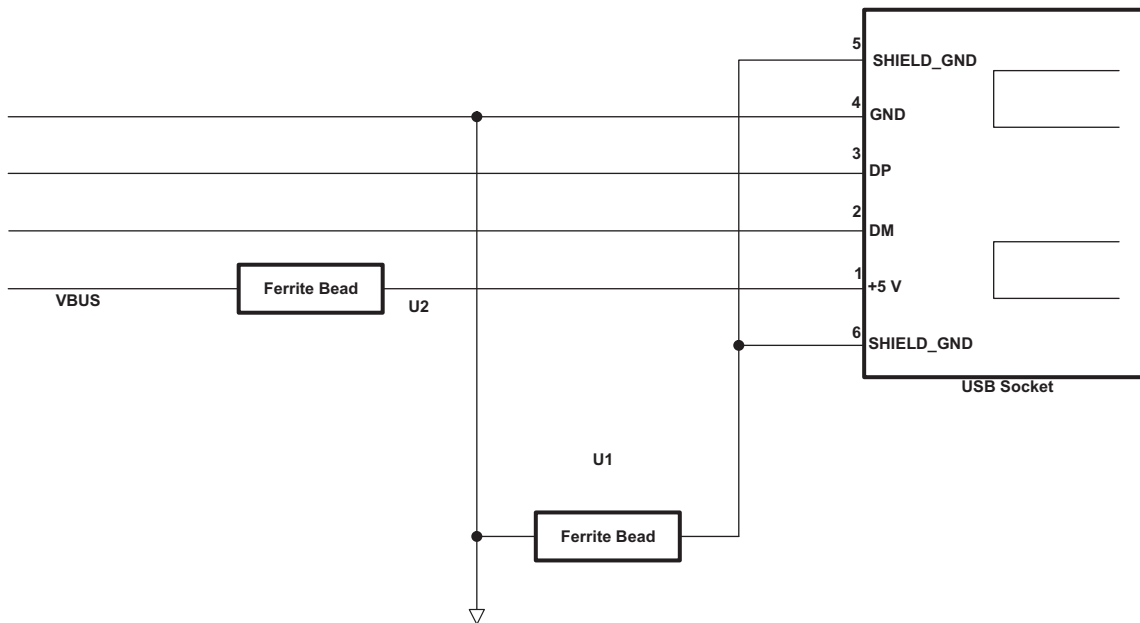

8-32. USB Connector

8.5.2.2.2.5 Clock Routings

To address the system clock emissions between devices, place a ~10 to 130 Ω resistor in series with the clock signal. Use a trial and error method of looking at the shape of the clock waveform on a high-speed oscilloscope and of tuning the value of the resistance to minimize waveform distortion. The value on this resistor should be as small as possible to get the desired effect. Place the resistor close to the device generating the clock signal. If an external crystal is used, follow the guidelines detailed in the *Selection and Specification of Crystals for Texas Instruments USB 2.0 Devices (SLLA122)*.

When routing the clock traces from one device to another, try to use the 3W spacing rule. The distance from the center of the clock trace to the center of any adjacent signal trace should be at least three times the width of the clock trace. Many clocks, including slow frequency clocks, can have fast rise and fall times. Using the 3W rule cuts down on crosstalk between traces. In general, leave space between each of the traces running parallel between the devices. Avoid using right angles when routing traces to minimize the routing distance and impedance discontinuities. For further protection from crosstalk, run guard traces beside the clock signals (GND pin to GND pin), if possible. This lessens clock signal coupling, as shown in 8-33.

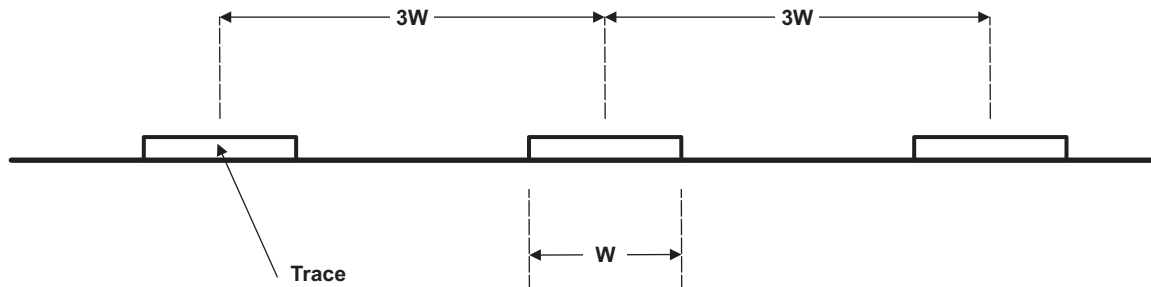

8-33. 3W Spacing Rule

8.5.2.2.6 Crystals/Oscillator

Keep the crystal and its load capacitors close to the USB PHY pins, XI and XO (see [Figure 8-34](#)). Note that frequencies from power sources or large capacitors can cause modulations within the clock and should not be placed near the crystal. In these instances, errors such as dropped packets occur. A placeholder for a resistor, in parallel with the crystal, can be incorporated in the design to assist oscillator startup.

Power is proportional to the current squared. The current is $I = C \cdot dv/dt$, because dv/dt is a function of the PHY, current is proportional to the capacitive load. Cutting the load to 1/2 decreases the current by 1/2 and the power to 1/4 of the original value. For more details on crystal selection, see the *Selection and Specification of Crystals for Texas Instruments USB 2.0 Devices (SLLA122)*.

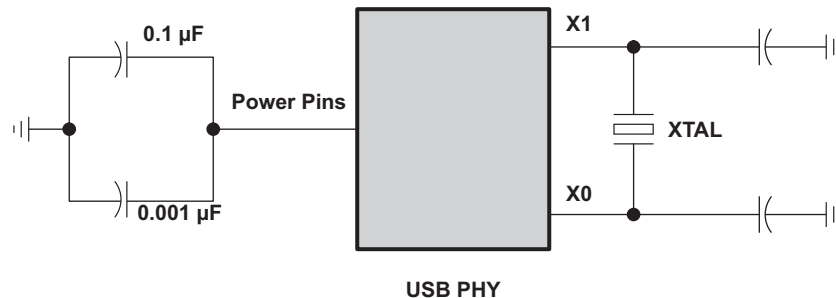
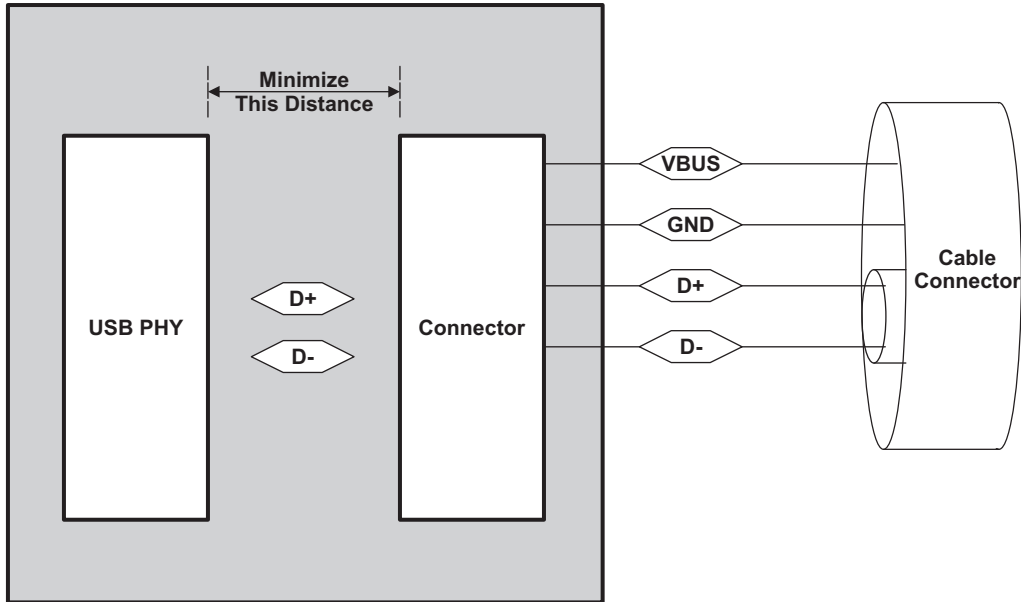

Figure 8-34. Power Supply and Clock Connection to the USB PHY

8.5.2.2.7 DP/DM Trace

Place the USB PHY as close as possible to the USB 2.0 connector. The signal swing during high-speed operation on the DP/DM lines is relatively small ($400 \text{ mV} \pm 10\%$), so any differential noise picked up on the twisted pair can affect the received signal. When the DP/DM traces do not have any shielding, the traces tend to behave like an antenna and picks up noise generated by the surrounding components in the environment. To minimize the effect of this behavior:

- DP/DM traces should always be matched lengths and must be no more than 4 inches in length; otherwise, the eye opening may be degraded (see [Figure 8-35](#)).
- Route DP/DM traces close together for noise rejection on differential signals, parallel to each other and within two mils in length of each other. The measurement for trace length must be started from device's balls.
- A high-speed USB connection is made through a shielded, twisted pair cable with a differential characteristic impedance of $90 \Omega \pm 15\%$. In layout, the impedance of DP and DM should each be $45 \Omega \pm 10\%$.
- DP/DM traces should not have any extra components to maintain signal integrity. For example, traces cannot be routed to two USB connectors.



8-35. USB PHY Connector and Cable Connector

8.5.2.2.2.8 DP/DM Vias

When a via must be used, increase the clearance size around it to minimize its capacitance. Each via introduces discontinuities in the signal's transmission line and increases the chance of picking up interference from the other layers of the board. Be careful when designing test points on twisted pair lines; through-hole pins are not recommended.

8.5.2.2.2.9 Image Planes

An image plane is a layer of copper (voltage plane or ground plane), physically adjacent to a signal routing plane. Use of image planes provides a low impedance, shortest possible return path for RF currents. For a USB board, the best image plane is the ground plane because it can be used for both analog and digital circuits.

- Do not route traces so they cross from one plane to the other. This can cause a broken RF return path resulting in an EMI radiating loop as shown in 8-36. This is important for higher frequency or repetitive signals. Therefore, on a multi-layer board, it is best to run all clock signals on the signal plane above a solid ground plane.
- Avoid crossing the image power or ground plane boundaries with high-speed clock signal traces immediately above or below the separated planes. This also holds true for the twisted pair signals (DP, DM). Any unused area of the top and bottom signal layers of the PCB can be filled with copper that is connected to the ground plane through vias.

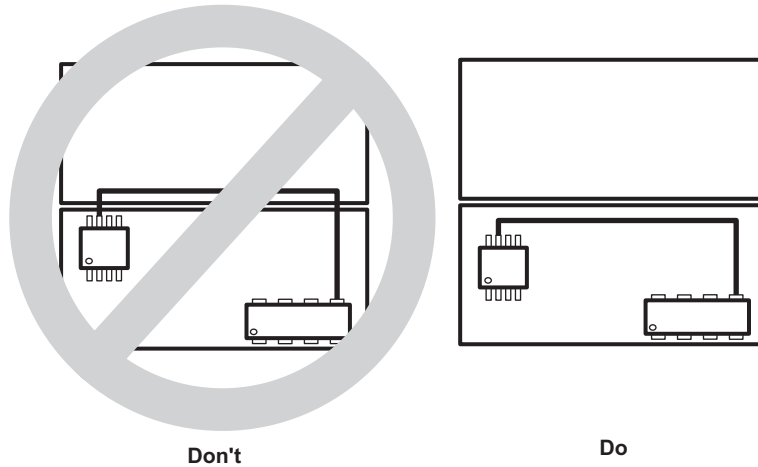

8-36. Do Not Cross Plane Boundaries

- Do not overlap planes that do not reference each other. For example, do not overlap a digital power plane with an analog power plane as this produces a capacitance between the overlapping areas that could pass RF emissions from one plane to the other, as shown in [8-37](#).

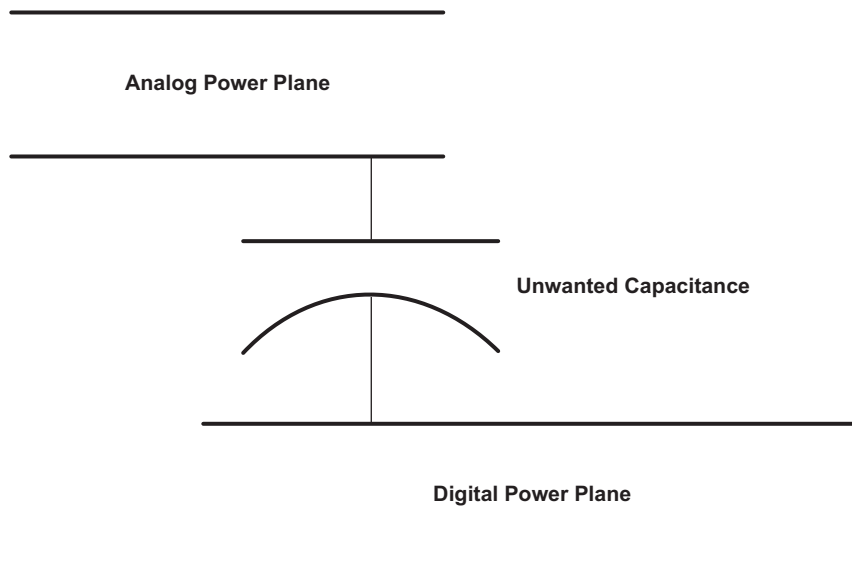

8-37. Do Not Overlap Planes

- Avoid image plane violations. Traces that route over a slot in an image plane results in a possible RF return loop, as shown in [8-38](#).

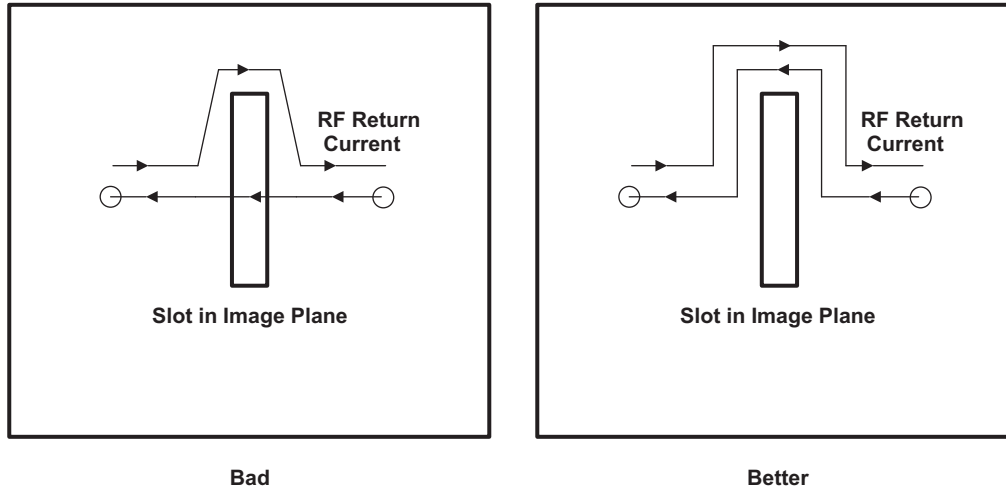

8-38. Do Not Violate Image Planes

8.5.2.2.2.10 JTAG Interface

For test and debug of the USB PHY only, an IEEE Standard 1149.1-1990, IEEE Standard Test Access Port and Boundary-Scan Architecture (JTAG) and Serial Test and Configuration Interface (STCI) may be available on the System-on-Chip (SoC). If available, keep the USB PHY JTAG interface less than six inches; keeping this distance short reduces noise coupling from other devices and signal loss due to resistance.

8.5.2.2.2.11 Power Regulators

Switching power regulators are a source of noise and can cause noise coupling if placed close to sensitive areas on a circuit board. Therefore, the switching power regulator should be kept away from the DP/DM signals, the external clock crystal (or clock oscillator), and the USB PHY.

8.5.2.3 Electrostatic Discharge (ESD)

International Electronic Commission (IEC) 61000-4-xx is a set of about 25 testing specifications from the IEC. IEC ESD Stressing is done both un-powered and with power applied, and with the device functioning. There must be no physical damage, and the device must keep working normally after the conclusion of the stressing. Typically, equipment has to pass IEC stressing at 8 kV contact and 15 kV air discharge, or higher. To market products/systems in the European community, all products/systems must be CE compliant and have the CE Mark. To obtain the CE Mark, all products/systems need to go through and pass IEC standard requirements; for ESD, it is 61000-4-2. 61000-4-2 requires that the products/systems pass contact discharge at 8 kV and air discharge at 15 kV. When performing an IEC ESD Stressing, only pins accessible to the *outside world* need to pass the test. The system into which the integrated circuit (IC) is placed makes a difference in how well the IC does. For example:

- Cable between the zap point and the IC attenuate the high frequencies in the waveform.
- Series inductance on the PCB board attenuates the high frequencies.
- Unless the capacitor's ground connection is inductive, capacitance to ground shunts away high frequencies.

8.5.2.3.1 IEC ESD Stressing Test

The following sections describe in detail the IEC ESD Stressing Test modes and test types.

8.5.2.3.1.1 Test Mode

The IEC ESD Stressing test is done through two modes: contact discharge mode and air discharge mode.

For the contact discharge test mode, the preferred way is direct contact applied to the conductive surfaces of the equipment under test (EUT). In the case of the USB system, the conductive surface is the outer casing of the USB connector. The electrode of the ESD generator is held in contact with the EUT or a coupling plane prior to discharge. The arc formation is created under controlled conditions, inside a relay, resulting in repeatable waveforms; however, this arc does not accurately recreate the characteristic unique to the arc of an actual ESD event.

8.5.2.3.1.2 Air Discharge Mode

The air discharge usually applies to a non-conductive surface of the EUT. Instead of a direct contact with the EUT, the charged electrode of the ESD generator is brought close to the EUT, and a spark in the air to the EUT actuates the discharge. Compared to the contact discharge mode, the air discharge is more realistic to the actual ESD occurrence. However, due to the variations of the arc length, it may not be able to produce repeatable waveform.

8.5.2.3.1.3 Test Type

The IEC ESD Stressing test has two test types: direct discharge and indirect discharge. Direct discharge is applied directly to the surface or the structure of the EUT. It includes both contact discharge and air discharge modes. Indirect discharge applies to a coupling plane in the vicinity of the EUT. The indirect discharge is used to simulate personal discharge to objects which are adjacent to the EUT. It includes contact discharge mode only.

8.5.2.3.2 TI Component Level IEC ESD Test

TI Component Level IEC ESD Test tests only the IC terminals that are exposed in system level applications. It can be used to determine the robustness of on-chip protection and the latch-up immunity. The IC can only pass the TI Component Level IEC ESD test when there is no latch-up and IC is fully functional after the test.

8.5.2.3.3 Construction of a Custom USB Connector

A standard USB connector, either type A or type B, provides good ESD protection. However, if a custom USB connector is desired, the following guidelines should be observed to ensure good ESD protection.

- There should be an easily accessible shield plate next to the connector for air-discharge mode purpose.
- Tie the outer shield of the connector to GND. When a cable is inserted into the connector, the shield of the cable should first make contact with the outer shield.
- If the connector includes power and GND, the lead of power and GND need to be longer than the leads of signal.
- The connector needs to have a key to ensure proper insertion of the cable.
- See the standard USB connector for reference.

8.5.2.3.4 ESD Protection System Design Consideration

ESD protection system design consideration is covered in [8.5.2.2](#) of this document. The following are additional considerations for ESD protection in a system.

- Metallic shielding for both ESD and EMI
- Chassis GND isolation from the board GND
- Air gap designed on board to absorb ESD energy
- Clamping diodes to absorb ESD energy
- Capacitors to divert ESD energy
- The use of external ESD components on the DP/DM lines may affect signal quality and are not recommended.

8.5.2.4 References

- *USB 2.0 Specification*, Intel, 2000, <http://www.usb.org/developers/docs/>
- *High Speed USB Platform Design Guidelines*, Intel, 2000, http://www.intel.com/technology/usb/download/usb2dg_R1_0.pdf
- *Selection and Specification of Crystals for Texas Instruments USB 2.0 Devices* ([SLLA122](#))

8.5.3 USB 3.0 Board Design and Layout Guidelines

This section provides the timing specification for the USB3.0 (USB1 in the device) interface as a PCB design and manufacturing specification. The design rules constrain PCB trace length, PCB trace skew, signal integrity, cross-talk, and signal timing. TI has performed the simulation and system design work to ensure the USB3.0 interface requirements are met. The design rules stated within this document are targeted at DEVICE mode electrical compliance. HOST mode and/or systems that do not include the 3m USB cable and far-end 11-inch PCB trace required by DEVICE mode compliance testing may not need the complete list of optimizations shown in this document; however, applying these optimizations to HOST mode systems will lead to optimal DEVICE mode performance.

8.5.3.1 USB 3.0 interface introduction

The USB 3.0 has two unidirectional differential pairs: TXp/TXn pair and RXp/RXn pair. AC coupling caps are needed on the board for TX traces.

☒ [8-39](#) present high level schematic diagram for USB 3.0 interface.

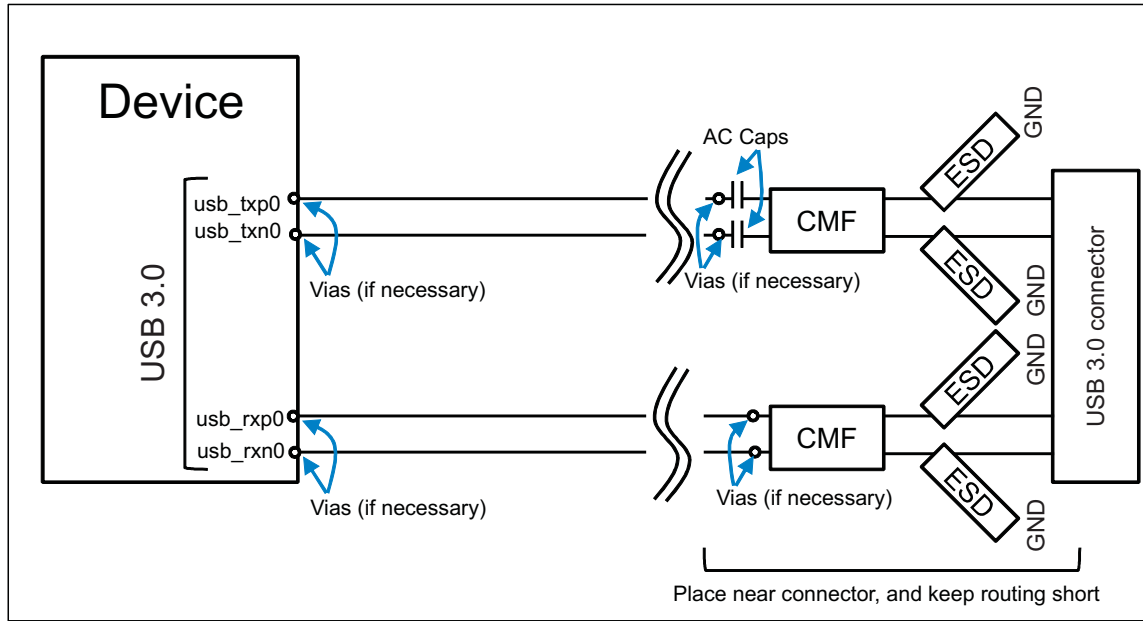

SPRS85x_PCB_USB30_1

图 8-39. USB 3.0 Interface High Level Schematic

注: ESD components should be on a PCB layer next to a system GND plane layer so the inductance of the via to GND will be minimal.

If vias are used, place the vias near the AC Caps or CMFs and under the SoC BGA, if necessary.

图 8-40 present placement diagram for USB 3.0 interface.

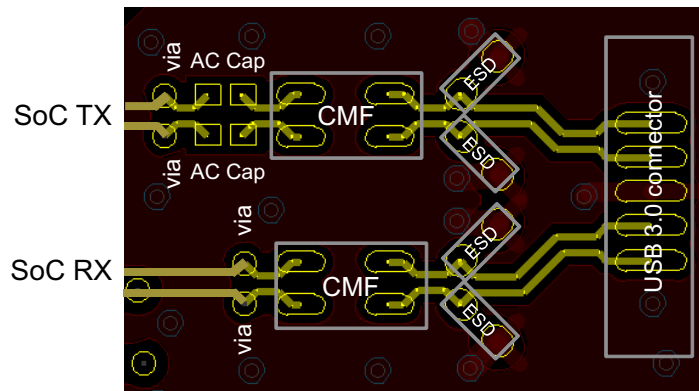

SPRS85x_PCB_USB30_2

图 8-40. USB 3.0 placement diagram

表 8-12. USB1 Component Reference

INTERFACE	COMPONENT	SUPPLIER	PART NUMBER
USB3 PHY	ESD	TI	TPD1E05U06
	CMF	Murata	DLW21SN900HQ2
	C	-	100nF (typical size: 0201)

8.5.3.2 USB 3.0 General routing rules

Some general routing guidelines regarding USB 3.0:

- Avoid crossing splits reference plane(s).
- Shorter trace length is preferred.
- Minimize the via usage and layer transition
- Keep large spacing between TX and RX pairs.
- Intra-lane delay mismatch between DP and DM less than 1ps. Same for RXp and RXn.
- Distance between common mode filter (CMF) and ESD protection device should be as short as possible
- Distance between ESD protection device and USB connector should be as short as possible.
- Distance between AC capacitors (TX only) and CMF should be as short as possible.
- USB 3.0 signals should always be routed over an adjacent ground plane.

表 8-13 and 表 8-14 present routing specification and recommendations for USB1 in the device.

表 8-13. USB1 Routing Specifications

PARAMETER	MIN	TYP	MAX	UNIT
Device balls to USB 3.0 connector trace length			3500	Mils
Skew within a differential pair		3	6	Mils
Number of stubs allowed on TX/RX traces			0	Stubs
TX/RX pair differential impedance	83.7	90	96.3	Ω
Number of vias on each TX/RX trace ⁽¹⁾			2	Vias
Differential pair to any other trace spacing ⁽²⁾ _{⁽³⁾ ⁽⁴⁾}	2xDS	3xDS		
Number of ground plane cuts allowed within USB3 routing region (except for specific ground carving as explained in this document)			0	Cuts
Number of layers between USB3.0 routing region and reference ground plane			0	Layers
PCB trace width		6		Mils
PCB BGA escape via pad size		18		Mils
PCB BGA escape via hole size		10		Mils

(1) Vias must be used in pairs and spaced equally along a signal path.

(2) DS = differential spacing of the traces.

(3) Exceptions may be necessary in the SoC package BGA area.

(4) GND guard-bands on the same layer may be closer, but should not be allowed to affect the impedance of the differential pair routing. GND guard-bands to isolate USB3.0 differential pairs from all other signals are recommended.

表 8-14. USB1 Routing Recommendations

Item	Description	Reason
ESD location	Place ESD component on same layer as connector (no via or stub to ESD component)	Eliminate reflection loss from via & stub to ESD
ESD part number	TPD1E05U06	Minimize capacitance (0.42pF)
CMF part number	DLW21SN900HQ2	Manufacturer's recommended device
Connector	Use USB3.0 connector with supporting s-parameter model	Enable full signal chain simulation
Carve Ground	Carve GND underneath AC Caps, ESD, CMF, and connector	Minimize capacitance under ESD and CMF
Round pads	Minimize pad size and round the corners of the pads for the ESD and CMF components	Minimize capacitance

表 8-14. USB1 Routing Recommendations (continued)

Item	Description	Reason
Vias	Max 2 vias per signal trace. If vias are required, place vias close to the AC Caps and CMFs. Vias under the SoC grid array may be used if necessary to route signals away from BGA pattern.	Vias significantly degrade signal integrity at 2.5GHz

☒ 8-41 presents an example layout, demonstrating the “carve GND” concept.

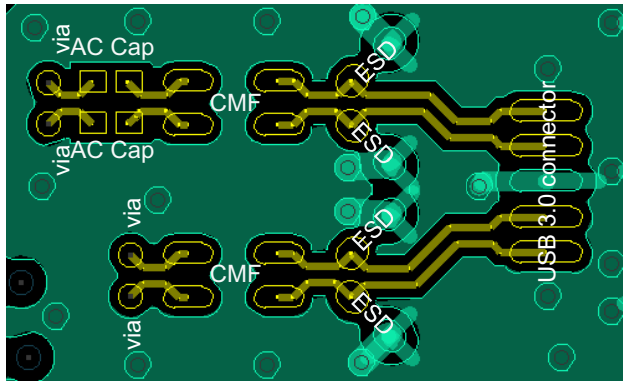

Top Layer: Routing from SoC through AC Caps, CMF, and ESD to connector.

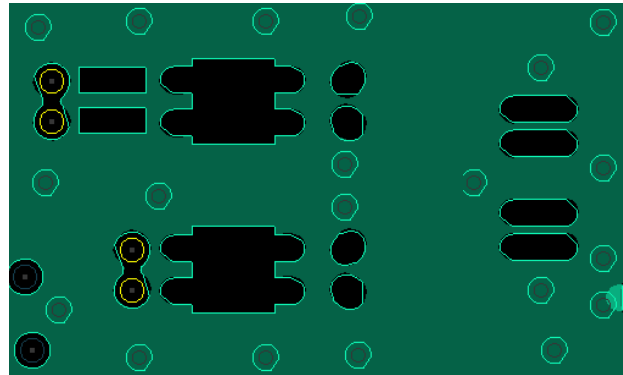

Layer2, GND: Gaps carved in GND underneath AC Caps, CMF, ESD, and connector.

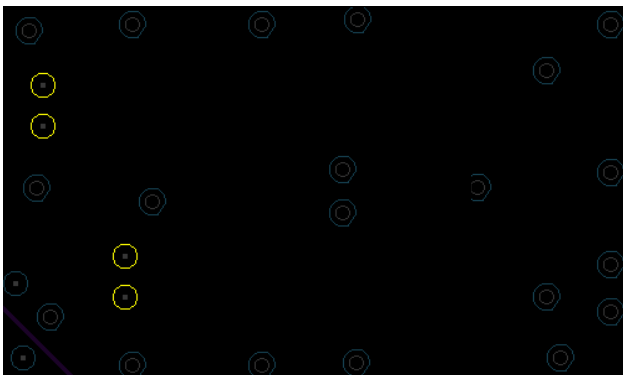

Layer3, Signal: Implement as keep-out zone underneath carved GND areas.

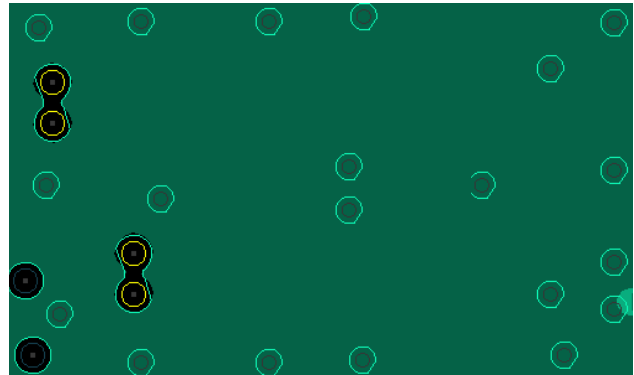

Layer4, GND Plane underneath AC Caps, CMF, ESD, and connector.

SPRS85x_PCB_USB30_3

☒ 8-41. USB 3.0 Example “carve GND” layout

8.5.4 HDMI Board Design and Layout Guidelines

This section provides the timing specification for the HDMI interface as a PCB design and manufacturing specification. The design rules constrain PCB trace length, PCB trace skew, signal integrity, cross-talk, and signal timing. TI has performed the simulation and system design work to ensure the HDMI interface requirements are met. The design rules stated within this document are targeted at resolutions less than or equal to 1080p60 with 8-bit color; deep color (10-bit) requires further signal integrity optimization.

8.5.4.1 HDMI Interface Schematic

The HDMI bus is separated into three main sections (HDMI Ethernet and the optional Audio Return Channel are not specifically supported by this Device):

1. Transition Minimized Differential Signaling (TMDS) high speed digital video interface

2. Display Data Channel (I2C bus for configuration and status exchange between two devices)
3. Consumer Electronics Control (optional) for remote control of connected devices.

The DDC and CEC are low speed interfaces, so nothing special is required for PCB layout of these signals.

The TMDS channels are high speed differential pairs and therefore require the most care in layout. Specifications for TMDS layout are below.

☒ 8-42 shows the HDMI interface schematic.

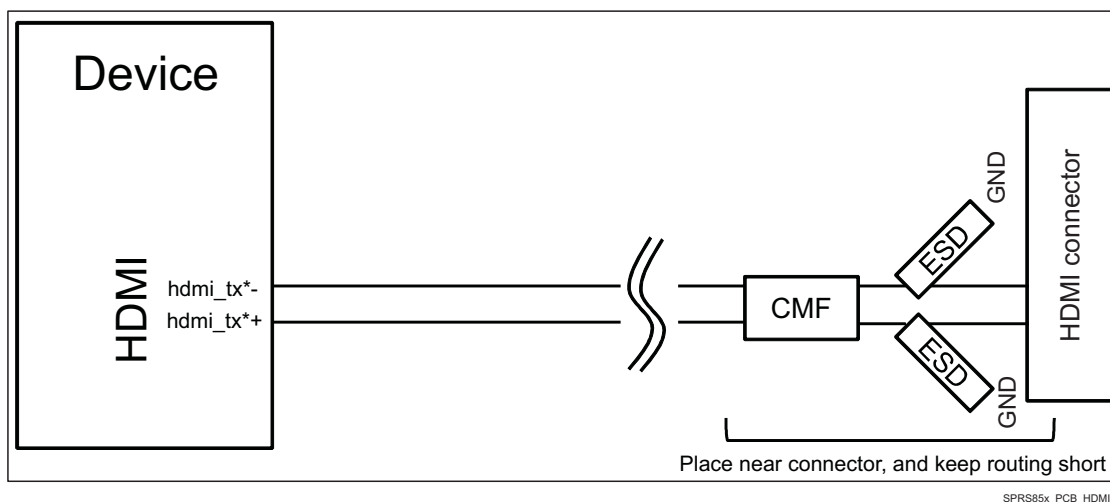

☒ 8-42. HDMI Interface High Level Schematic

☒ 8-43 presents placement diagram for HDMI interface.

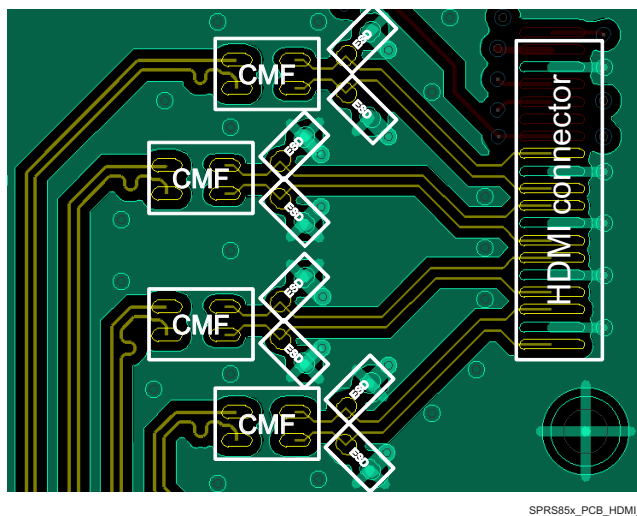

☒ 8-43. HDMI Placement Diagram

表 8-15. HDMI Component Reference

INTERFACE	DEVICE	SUPPLIER	PART NUMBER
HDMI	ESD	TI	TPD1E05U06
	CMF	Murata	DLW21SN900HQ2

8.5.4.2 TMDS General Routing Guidelines

The TMDS signals are high speed differential pairs. Care must be taken in the PCB layout of these signals to ensure good signal integrity.

The TMDS differential signal traces must be routed to achieve 100 Ohms (+/- 10%) differential impedance and 60 ohms (+/-10%) single ended impedance. Single ended impedance control is required because differential signals can't be closely coupled on PCBs and therefore single ended impedance becomes important.

These impedances are impacted by trace width, trace spacing, distance to reference planes, and dielectric material. Verify with a PCB design tool that the trace geometry for both data signal pairs results in as close to 60 ohms impedance traces as possible. For best accuracy, work with your PCB fabricator to ensure this impedance is met.

In general, closely coupled differential signal traces are not an advantage on PCBs. When differential signals are closely coupled, tight spacing and width control is necessary. Very small width and spacing variations affect impedance dramatically, so tight impedance control can be more problematic to maintain in production.

Loosely coupled PCB differential signals make impedance control much easier. Wider traces and spacing make obstacle avoidance easier, and trace width variations don't affect impedance as much, therefore it's easier to maintain accurate impedance over the length of the signal. The wider traces also show reduced skin effect and therefore often result in better signal integrity.

Some general routing guidelines regarding TMDS:

- Avoid crossing splits reference plane(s).
- Shorter trace length is preferred.
- Distance between common mode filter (CMF) and ESD protection device should be as short as possible
- Distance between ESD protection device and HDMI connector should be as short as possible.

表 8-16 shows the routing specifications for the TMDS signals.

表 8-16. TMDS Routing Specifications

PARAMETER	MIN	TYP	MAX	UNIT
Device balls to HDMI header trace length			4000	Mils
Skew within a differential pair		3	5	Mils
Number of stubs allowed on TMDS traces			0	stubs
TMDS pair differential impedance	90	100	110	Ω
TMDS single-ended impedance	54	60	66	Ω
Number of vias on each TMDS trace			0	Vias
TMDS differential pair to any other trace spacing ^{(1) (2) (3)}	2xDS	3xDS		Mils
Number of ground plane cuts allowed within HDMI routing region (except for specific ground carving as explained in this document)			0	Cuts
Number of layers between HDMI routing region and reference ground plane			0	Layers
PCB trace width		4.4		Mils

(1) DS = differential spacing of the traces.

(2) Exceptions may be necessary in the SoC package BGA area.

(3) GND guard-bands may be closer, but should not be allowed to affect the impedance of the differential pair routing. GND guard-bands to isolate HDMI differential pairs from all other signals is recommended.

表 8-17. TDMS Routing Recommendations

Item	Description	Reason
ESD part number	TPD1E05U06	Minimize capacitance (0.42pF)

表 8-17. TDMS Routing Recommendations (continued)

Item	Description	Reason
Carve Ground	Carve GND underneath ESD and CMF	Minimize capacitance under ESD and CMF
Round pads	Reduce pad size and round the corners of the pads for the ESD and CMF components	Minimize capacitance
Routing layer	Route all signals only on the same layer as SoC	Minimize reflection loss

☒ 8-44 presents an example layout, demonstrating the “carve GND” concept.

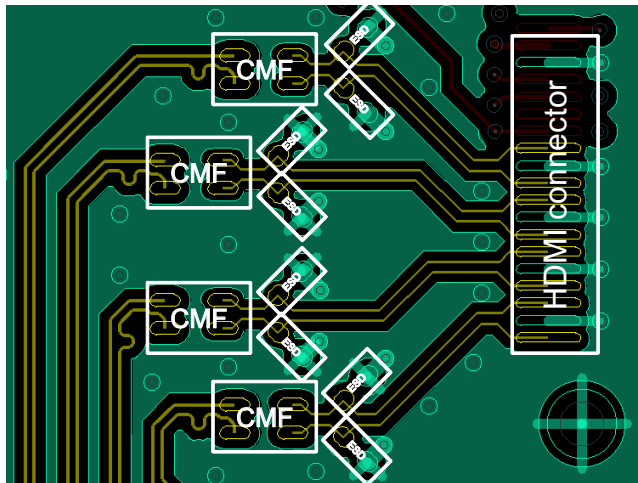

Top Layer: Routing from SoC through CMF, and ESD to connector.

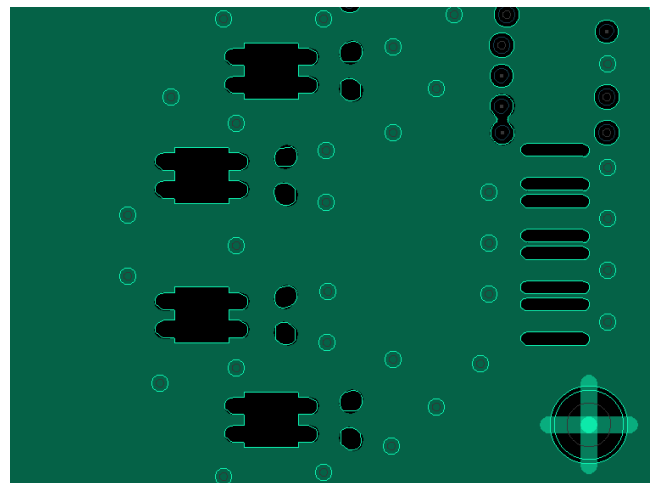

Layer2, GND: Gaps carved in GND underneath, CMF, ESD, and connector.

SPRS85x_PCB_HDMI_3

☒ 8-44. HDMI Example “carve GND” layout

8.5.4.3 TPD5S115

The TPD5S115 is an integrated HDMI companion chip solution. The device provides a regulated 5 V output (5VOUT) for sourcing the HDMI power line. The TPD5S115 exceeds the IEC61000-4-2 (Level 4) ESD protection level.

8.5.4.4 HDMI ESD Protection Device (Required)

Interfaces that connect to a cable such as HDMI generally require more ESD protection than can be built into the processor’s outputs. Therefore this HDMI interface requires the use of an ESD protection chip to provide adequate ESD.

When selecting an ESD protection chip, choose the lowest capacitance ESD protection available to minimize signal degradation. In no case should be ESD protection circuit capacitance be more than 5pF.

TI manufactures these devices that provide ESD protection for HDMI signals such as the TPDxE05U06. For more information see the www.ti.com website.

8.5.4.5 PCB Stackup Specifications

表 8-18 shows the stackup and feature sizes required for HDMI.

表 8-18. HDMI PCB Stackup Specifications

PARAMETER	MIN	TYP	MAX	UNIT
PCB Routing/Plane Layers	4	6	-	Layers

表 8-18. HDMI PCB Stackup Specifications (continued)

PARAMETER	MIN	TYP	MAX	UNIT
Signal Routing Layers	2	3	-	Layers
Number of ground plane cuts allowed within HDMI routing region	-	-	0	Cuts
Number of layers between HDMI routing region and reference ground plane	-	-	0	Layers
PCB Trace width		4		Mils

8.5.4.6 Grounding

Each TMDS channel has its own shield pin and they should be grounded to provide a return current path for the TMDS signal.

8.5.5 SATA Board Design and Layout Guidelines

The device provides one SATA port. This section provides the timing specification for the SATA interface as a PCB design and manufacturing specification. The design rules constrain PCB trace length, PCB trace skew, signal integrity, cross-talk, and signal timing. TI has performed the simulation and system design work to ensure the SATA interface requirements are met.

8.5.5.1 SATA Interface Schematic

图 8-45 shows the data portion of the SATA interface schematic.



图 8-45. SATA Interface High Level Schematic

注: AC coupling capacitors (C) are required on the receive and transmit data pairs. 表 8-19 shows the requirements for these capacitors.

表 8-19. SATA AC Coupling Capacitors Requirements

PARAMETER	MIN	TYP	MAX	UNIT
SATA AC coupling capacitor value	0.3	10	12	nF
SATA AC coupling capacitor package size		0402	0603	EIA ⁽¹⁾⁽²⁾

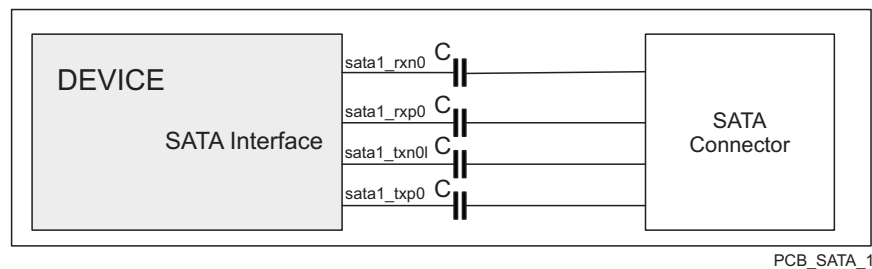
(1) EIA LxW units, i.e., a 0402 is a 40x20 mils surface mount capacitor.

(2) The physical size of the capacitor should be as small as practical. Use the same size on both lines in each pair placed side by side.

8.5.5.2 Compatible SATA Components and Modes

表 8-20 shows the compatible SATA components and supported modes. Note that the only supported configuration is an internal cable from the processor host to the SATA device.

表 8-20. Compatible SATA Components and Modes

PARAMETER	MIN	MAX	UNIT	SUPPORTED
Transfer Rates	1.5	3	Gbps	

表 8-20. Compatible SATA Components and Modes (continued)

PARAMETER	MIN	MAX	UNIT	SUPPORTED
Internal Cable	-	-	-	YES

8.5.5.3 PCB Stackup Specifications

表 8-21 shows the stackup and feature sizes required for these types of SATA connections.

表 8-21. SATA PCB Stackup Specifications

PARAMETER	MIN	TYP	MAX	UNIT
Number of ground plane cuts allowed within SATA routing region	-	-	0	Cuts
Number of layers between SATA routing area and reference plane	-	-	0	Layers
PCB Routing clearance		4		Mils
PCB Trace width		4		Mils

8.5.5.4 Routing Specifications

The SATA data signal traces must be routed to achieve 100 Ohms (+/-10%) differential impedance and 60 ohms (+/-10%) single ended impedance. The signal ended impedance is required because differential signals can't be closely coupled on PCBs and therefore single ended impedance becomes important. 60 ohms is chosen for the single ended impedance to minimize problems caused by too low an impedance.

These impedances are impacted by trace width, trace spacing, distance to reference planes, and dielectric material. Verify with a PCB design tool that the trace geometry for both data signal pairs results in as close to 100 ohms differential and 60 ohms single ended impedance traces as possible. For best accuracy, work with your PCB fabricator to ensure this impedance is met.

表 8-22 shows the routing specifications for the SATA data signals.

表 8-22. SATA Routing Specifications

PARAMETER	MIN	TYP	MAX	UNIT
SATA signal trace length (device balls to SATA connector)			3050 ⁽¹⁾	Mils
Differential pair trace skew matching			5	Mils
Number of stubs allowed on SATA traces ⁽²⁾			0	stubs
TX/RX pair differential impedance	90	100	110	Ω
TX/RX single-ended impedance	54	60	66	Ω
Number of vias on each SATA trace			0	Vias
SATA differential pair to any other trace spacing	2xDS ⁽³⁾			

(1) Beyond this, signal integrity may suffer.

(2) Inline pads may be used for probing.

(3) DS = differential spacing of the SATA traces.

表 8-23. SATA Routing Recommendations

Item	Description	Reason
ESD part number	None	ESD suppression generally not used on SATA

8.5.6 PCIe Board Design and Layout Guidelines

The PCIe interface on the device provides support for a 5.0 Gbps lane with polarity inversion.

8.5.6.1 PCIe Connections and Interface Compliance

The PCIe interface on the device is compliant with the PCIe revision 3.0 specification. Please refer to the PCIe specifications for all connections that are described in it. Those recommendations are more descriptive and exhaustive than what is possible here.

The use of PCIe compatible bridges and switches is allowed for interfacing with more than one other processor or PCIe device.

8.5.6.1.1 Coupling Capacitors

AC coupling capacitors are required on the transmit data pair. 表 8-24 shows the requirements for these capacitors.

表 8-24. PCIe AC Coupling Capacitors Requirements

PARAMETER	MIN	TYP	MAX	UNIT
PCIe AC coupling capacitor value	90	100	110	nF
PCIe AC coupling capacitor package size		0402	0603	EIA ⁽¹⁾⁽²⁾

(1) EIA LxW units, i.e., a 0402 is a 40x20 mils surface mount capacitor.

(2) The physical size of the capacitor should be as small as practical. Use the same size on both lines in each pair placed side by side.

8.5.6.1.2 Polarity Inversion

The PCIe specification requires polarity inversion support. This means for layout purposes, polarity is unimportant because each signal can change its polarity on die inside the chip. This means polarity within a lane is unimportant for layout.

8.5.6.2 Non-standard PCIe connections

The following sections contain suggestions for any PCIe connection that is NOT described in the official PCIe specification, such as an on-board Device to Device or Device to other PCIe compliant processor connection.

8.5.6.2.1 PCB Stackup Specifications

表 8-25 shows the stackup and feature sizes required for these types of PCIe connections.

表 8-25. PCIe PCB Stackup Specifications

PARAMETER	MIN	TYP	MAX	UNIT
Number of ground plane cuts allowed within PCIe routing region	-	-	0	Cuts
Number of layers between PCIe routing area and reference plane ⁽¹⁾	-	-	0	Layers
PCB Routing clearance		4		Mils
PCB Trace width		4		Mils

(1) A reference plane may be a ground plane or the power plane referencing the PCIe signals.

8.5.6.2.2 Routing Specifications

8.5.6.2.2.1 Impedance

The PCIe data signal traces must be routed to achieve 100-Ω (±10%) differential impedance and 60-Ω (±10%) single-ended impedance. The single-ended impedance is required because differential signals are extremely difficult to closely couple on PCBs and, therefore, single-ended impedance becomes important. These requirements are the same as those recommended in the PCIe Motherboard Checklist 1.0 document, available from PCI-SIG (www.pcisig.com).

These impedances are impacted by trace width, trace spacing, distance between signals and referencing planes, and dielectric material. Verify with a PCB design tool that the trace geometry for both data signal pairs result in as close to 100-Ω differential impedance and 60-Ω single-ended impedance as possible. For best accuracy, work with your PCB fabricator to ensure this impedance is met. See [表 8-26](#) below.

8.5.6.2.2.2 Differential Coupling

In general, closely coupled differential signal traces are not an advantage on PCBs. When differential signals are closely coupled, tight spacing and width control is necessary. Very small width and spacing variations affect impedance dramatically, so tight impedance control can be more problematic to maintain in production. For PCBs with very tight space limitations (which are usually small) this can work, but for most PCBs, the loosely coupled option is probably best.

Loosely coupled PCB differential signals make impedance control much easier. Wider traces and spacing make obstacle avoidance easier (because each trace is not so fixed in position relative to the other), and trace width variations don't affect impedance as much, therefore it's easier to maintain an accurate impedance over the length of the signal. For longer routes, the wider traces also show reduced skin effect and therefore often result in better signal integrity with a larger eye diagram opening.

[表 8-26](#) shows the routing specifications for the PCIe data signals.

表 8-26. PCI-E Routing Specifications

PARAMETER	MIN	TYP	MAX	UNIT
PCIe signal trace length (device balls to PCIe connector)			4700 ⁽¹⁾	Mills
Differential pair trace matching			5 ⁽²⁾	Mils
Number of stubs allowed on PCIe traces ⁽³⁾			0	stubs
TX/RX pair differential impedance	90	100	110	Ω
TX/RX single-ended impedance	54	60	66	Ω
Pad size of vias on PCIe trace			25 ⁽⁴⁾	Mils
Hole size of vias on PCIe trace			14	Mils
Number of vias on each PCIe trace			0	Vias
PCIe differential pair to any other trace spacing	2xDS ⁽⁵⁾			

(1) Beyond this, signal integrity may suffer.

(2) For example, RXP0 within 5 Mils of RXN0.

(3) Inline pads may be used for probing.

(4) 35-Mil antipad maximum recommended.

(5) DS = differential spacing of the PCIe traces.

表 8-27. PCI-E Routing Recommendations

Item	Description	Reason
ESD part number	None	ESD suppression generally not used on PCIe

8.5.6.2.2.3 Pair Length Matching

Each signal in the differential pair should be matched to within 5 mils of its matching differential signal. Length matching should be done as close to the mismatch as possible.

8.5.6.3 LJC_B_REFN/P Connections

A Common Refclk Rx Architecture is required to be used for the device PCIe interface. Specifically, two modes of Common Refclk Rx Architecture are supported:

- **External REFCLK Mode:** An common external 100MHz clock source is distributed to both the Device and the link partner
- **Output REFCLK Mode:** A 100MHz HCSL clock source is output by the device and used by the link partner

In **External REFCLK Mode**, a high-quality, low-jitter, differential HCSL 100MHz clock source compliant to the PCIe REFCLK AC Specifications should be provided on the Device's `ljcb_clkn` / `ljcb_clkp` inputs. Alternatively, an LVDS clock source can be used with the following additional requirements:

- External AC coupling capacitors described in 表 8-28 should be populated at the `ljcb_clkn` / `ljcb_clkp` inputs.
- All termination requirements (ex. parallel 100ohm termination) from the clock source manufacturer should be followed.

In **Output REFCLK Mode**, the 100MHz clock from the Device's `DPLL_PCIE_REF` should be output on the Device's `ljcb_clkn` / `ljcb_clkp` pins and used as the HCSL REFCLK by the link partner. External near-side termination to ground described in 表 8-29 is required on both of the `ljcb_clkn` / `ljcb_clkp` outputs in this mode.

表 8-28. LJC_B_REFN/P Requirements in External LVDS REFCLK Mode

PARAMETER	MIN	TYP	MAX	UNIT
<code>ljcb_clkn</code> / <code>ljcb_clkp</code> AC coupling capacitor value		100		nF
<code>ljcb_clkn</code> / <code>ljcb_clkp</code> AC coupling capacitor package size		0402	0603	EIA ⁽¹⁾⁽²⁾

(1) EIA LxW units, i.e., a 0402 is a 40x20 mils surface mount capacitor.

(2) The physical size of the capacitor should be as small as practical. Use the same size on both lines in each pair placed side by side.

表 8-29. LJC_B_REFN/P Requirements in Output REFCLK Mode

PARAMETER	MIN	TYP	MAX	UNIT
<code>ljcb_clkn</code> / <code>ljcb_clkp</code> near-side termination to ground value	47.5	50	52.5	Ohms

8.6 Clock Routing Guidelines

8.6.1 32-kHz Oscillator Routing

When designing the printed-circuit board:

- Keep the crystal as close as possible to the crystal pins X1 and X2.
- Keep the trace lengths short and small to reduce capacitor loading and prevent unwanted noise pickup.
- Place a guard ring around the crystal and tie the ring to ground to help isolate the crystal from unwanted noise pickup.
- Keep all signals out from beneath the crystal and the X1 and X2 pins to prevent noise coupling.

- Finally, an additional local ground plane on an adjacent PCB layer can be added under the crystal to shield it from unwanted pickup from traces on other layers of the board. This plane must be isolated from the regular PCB ground plane and tied to the GND pin of the RTC. The plane must not be any larger than the perimeter of the guard ring. Make sure that this ground plane does not contribute to significant capacitance (a few pF) between the signal line and ground on the connections that run from X1 and X2 to the crystal.

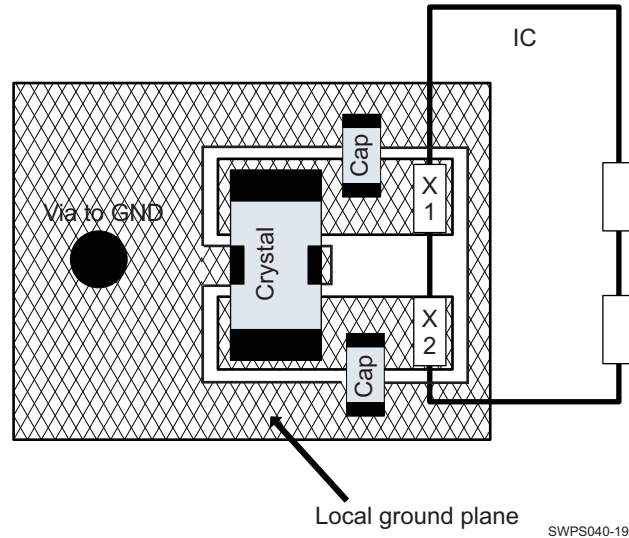

8-46. Slow Clock PCB Requirements

8.6.2 Oscillator Ground Connection

Although the impedance of a ground plane is low it is, of course, not zero. Therefore, any noise current in the ground plane causes a voltage drop in the ground. 8-47 shows the grounding scheme for slow (low frequency) clock generated from the internal oscillator.

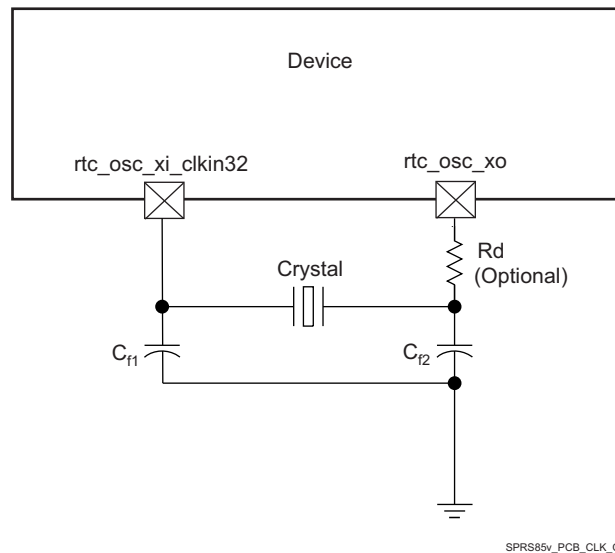

8-47. Grounding Scheme for Low-Frequency Clock

8-48 shows the grounding scheme for high-frequency clock.

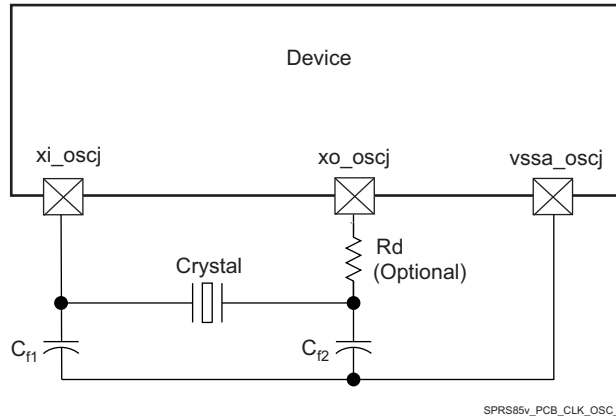

SPRS85v_PCB_CLK_OSC_3

(1) j in $*_{osc} = 0$ or 1

8-48. Grounding Scheme for High-Frequency Clock

8.7 DDR2/DDR3 Board Design and Layout Guidelines

8.7.1 DDR2/DDR3 General Board Layout Guidelines

To help ensure good signaling performance, consider the following board design guidelines:

- Avoid crossing splits in the power plane.
- Minimize Vref noise.
- Use the widest trace that is practical between decoupling capacitors and memory module.
- Maintain a single reference.
- Minimize ISI by keeping impedances matched.
- Minimize crosstalk by isolating sensitive bits, such as strobes, and avoiding return path discontinuities.
- Use proper low-pass filtering on the Vref pins.
- Keep the stub length as short as possible.
- Add additional spacing for on-clock and strobe nets to eliminate crosstalk.
- Maintain a common ground reference for all bypass and decoupling capacitors.
- Take into account the differences in propagation delays between microstrip and stripline nets when evaluating timing constraints.

8.7.2 DDR2 Board Design and Layout Guidelines

8.7.2.1 Board Designs

TI only supports board designs that follow the guidelines outlined in this document. The switching characteristics and the timing diagram for the DDR2 memory controller are shown in 表 8-30 and 8-49.

表 8-30. Switching Characteristics Over Recommended Operating Conditions for DDR2 Memory Controller

NO.	PARAMETER	DESCRIPTION	MIN	MAX	UNIT
DDR21	$t_c(DDR_CLK)$	Cycle time, DDR_CLK	2.5	8	ns

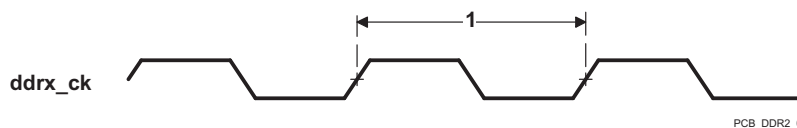

PCB_DDR2_0

8-49. DDR2 Memory Controller Clock Timing

8.7.2.2 DDR2 Interface

This section provides the timing specification for the DDR2 interface as a PCB design and manufacturing specification. The design rules constrain PCB trace length, PCB trace skew, signal integrity, cross-talk, and signal timing. These rules, when followed, result in a reliable DDR2 memory system without the need for a complex timing closure process. For more information regarding the guidelines for using this DDR2 specification, see the [Understanding TI's PCB Routing Rule-Based DDR Timing Specification](#).

8.7.2.2.1 DDR2 Interface Schematic

[Figure 8-50](#) shows the DDR2 interface schematic for a x32 DDR2 memory system. In [Figure 8-51](#) the x16 DDR2 system schematic is identical except that the high-word DDR2 device is deleted.

When not using all or part of a DDR2 interface, the proper method of handling the unused pins is to tie off the `ddrx_dqsi` pins to ground via a 1k- Ω resistor and to tie off the `ddrx_dqsni` pins to the corresponding `vdds_ddrx` supply via a 1k- Ω resistor. This needs to be done for each byte not used. The `vdds_ddrx` and `ddrx_vref0` power supply pins need to be connected to their respective power supplies even if DDRx is not being used. All other DDR interface pins can be left unconnected. Note that the supported modes for use of the DDR EMIF are 32-bits wide, 16-bits wide, or not used.

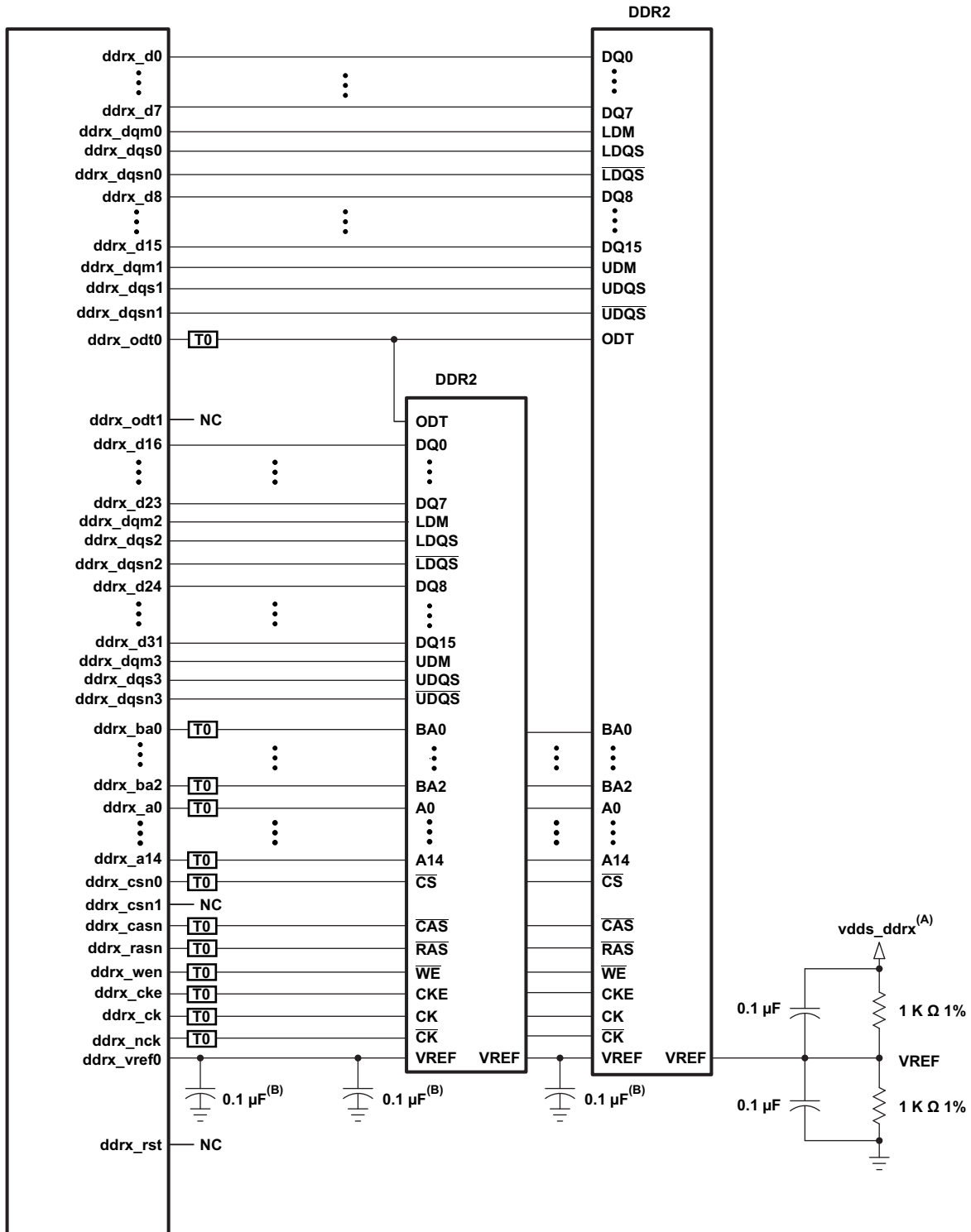

T0 Termination is required. See terminator comments.

PCB_DDR2_1

- A. vdds_ddrx is the power supply for the DDR2 memories and the Device DDR2 interface.
- B. One of these capacitors can be eliminated if the divider and its capacitors are placed near a VREF pin.

8-50. 32-Bit DDR2 High-Level Schematic

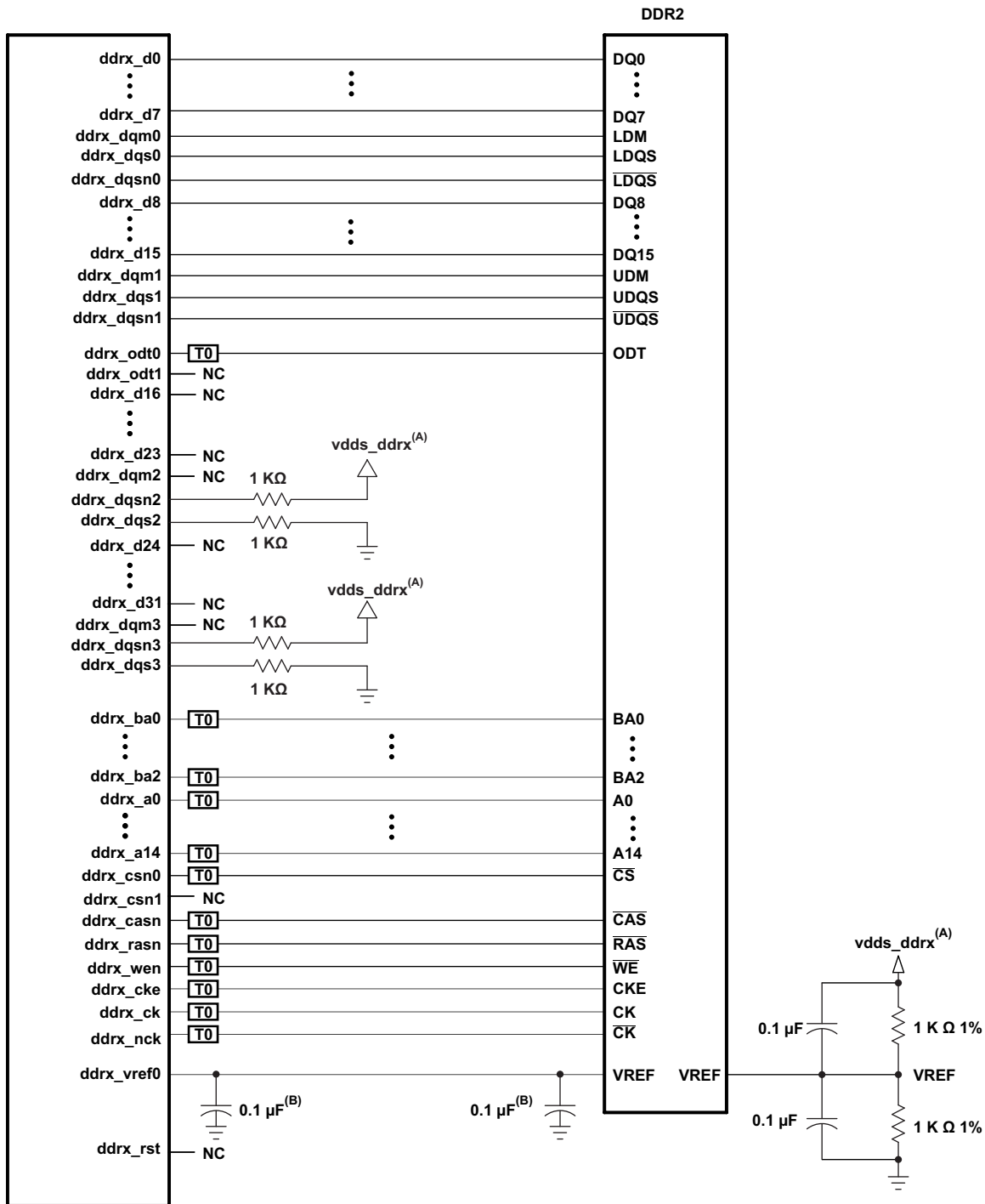

T0 Termination is required. See terminator comments.

PCB_DDR2_2

- A. vdds_ddrx is the power supply for the DDR2 memories and the Device DDR2 interface.
- B. One of these capacitors can be eliminated if the divider and its capacitors are placed near a VREF pin.

8-51. 16-Bit DDR2 High-Level Schematic

8.7.2.2.2 Compatible JEDEC DDR2 Devices

表 8-31 shows the parameters of the JEDEC DDR2 devices that are compatible with this interface. Generally, the DDR2 interface is compatible with x16 DDR2-800 speed grade DDR2 devices.

表 8-31. Compatible JEDEC DDR2 Devices (Per Interface)

NO.	PARAMETER	MIN	MAX	UNIT
CJ21	JEDEC DDR2 device speed grade ⁽¹⁾	DDR2-800		
CJ22	JEDEC DDR2 device bit width	x16	x16	Bits
CJ23	JEDEC DDR2 device count ⁽²⁾	1	2	Devices
CJ24	JEDEC DDR2 device ball count ⁽³⁾	84	92	Balls

(1) Higher DDR2 speed grades are supported due to inherent JEDEC DDR2 backwards compatibility.

(2) One DDR2 device is used for a 16-bit DDR2 memory system. Two DDR2 devices are used for a 32-bit DDR2 memory system.

(3) The 92-ball devices are retained for legacy support. New designs will migrate to 84-ball DDR2 devices. Electrically, the 92- and 84-ball DDR2 devices are the same.

8.7.2.2.3 PCB Stackup

The minimum stackup required for routing the Device is a six-layer stackup as shown in 表 8-32. Additional layers may be added to the PCB stackup to accommodate other circuitry or to reduce the size of the PCB footprint.

表 8-32. Minimum PCB Stackup

LAYER	TYPE	DESCRIPTION
1	Signal	Top routing mostly horizontal
2	Plane	Ground
3	Plane	Power
4	Signal	Internal routing
5	Plane	Ground
6	Signal	Bottom routing mostly vertical

Complete stackup specifications are provided in 表 8-33.

表 8-33. PCB Stackup Specifications

NO.	PARAMETER	MIN	TYP	MAX	UNIT
PS21	PCB routing/plane layers	6			
PS22	Signal routing layers	3			
PS23	Full ground reference layers under DDR2 routing region ⁽¹⁾	1			
PS24	Full vdds_ddrx power reference layers under the DDR2 routing region ⁽¹⁾	1			
PS25	Number of reference plane cuts allowed within DDR routing region ⁽²⁾			0	
PS26	Number of layers between DDR2 routing layer and reference plane ⁽³⁾			0	
PS27	PCB routing feature size		4		Mils
PS28	PCB trace width, w		4		Mils
PS29	Single-ended impedance, Z ₀	50		75	Ω
PS210	Impedance control ⁽⁵⁾	Z-5	Z	Z+5	Ω

(1) Ground reference layers are preferred over power reference layers. Be sure to include bypass caps to accommodate reference layer return current as the trace routes switch routing layers. A full ground reference layer should be placed adjacent to each DDR routing layer in PCB stack up.

(2) No traces should cross reference plane cuts within the DDR routing region. High-speed signal traces crossing reference plane cuts create large return current paths which can lead to excessive crosstalk and EMI radiation.

(3) Reference planes are to be directly adjacent to the signal plane to minimize the size of the return current loop.

(4) An 18-mil pad assumes Via Channel is the most economical BGA escape. A 20-mil pad may be used if additional layers are available for power routing. An 18-mil pad is required for minimum layer count escape.

(5) Z is the nominal singled-ended impedance selected for the PCB specified by PS29.

8.7.2.2.4 Placement

Figure 8-52 shows the required placement for the Device as well as the DDR2 devices. The dimensions for this figure are defined in Table 8-34. The placement does not restrict the side of the PCB on which the devices are mounted. The ultimate purpose of the placement is to limit the maximum trace lengths and allow for proper routing space. For a 16-bit DDR memory system, the high-word DDR2 device is omitted from the placement.

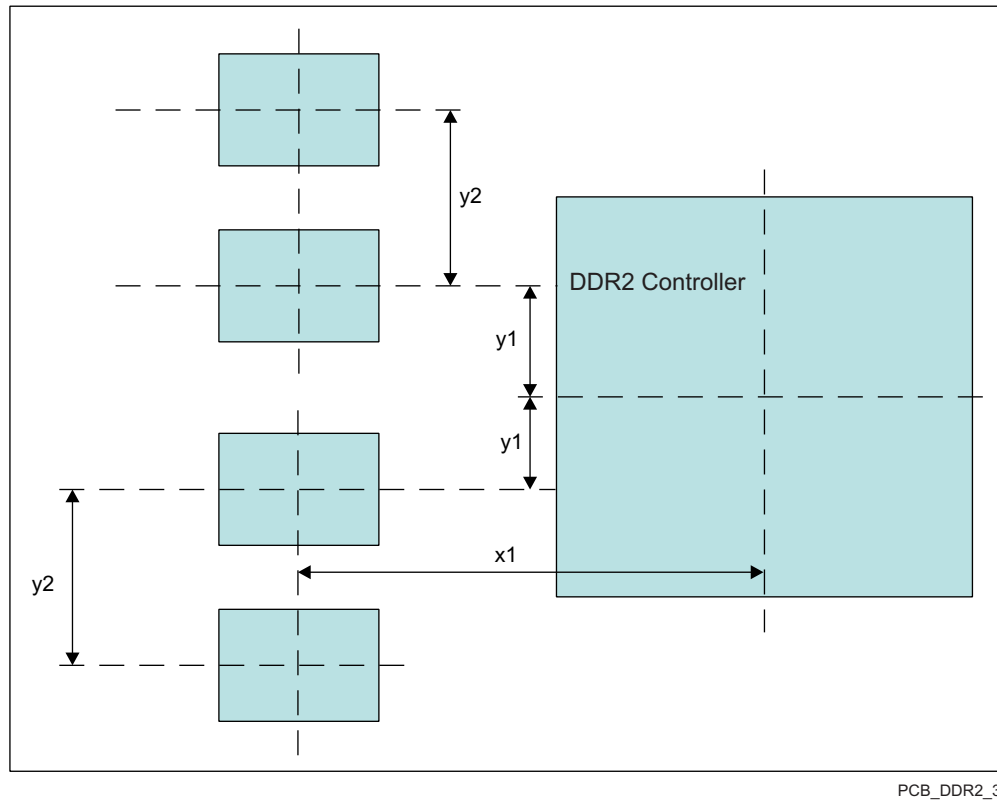

Figure 8-52. Device and DDR2 Device Placement

Table 8-34. Placement Specifications DDR2

NO.	PARAMETER	MIN	MAX	UNIT
KOD21	X1		2000	Mils
KOD22	Y1		500	Mils
KOD23	Y2		1300	Mils
KOD24	DDR2 keepout region ⁽¹⁾			
KOD25	Clearance from non-DDR2 signal to DDR2 keepout region ^{(2) (3)}		4	W

(1) DDR2 keepout region to encompass entire DDR2 routing area.

(2) Non-DDR2 signals allowed within DDR2 keepout region provided they are separated from DDR2 routing layers by a ground plane.

(3) If a device has more than one DDR controller, the signals from the other controller(s) are considered non-DDR2 and should be separated by this specification.

8.7.2.2.5 DDR2 Keepout Region

The region of the PCB used for the DDR2 circuitry must be isolated from other signals. The DDR2 keepout region is defined for this purpose and is shown in [Figure 8-53](#). The size of this region varies with the placement and DDR routing. Additional clearances required for the keepout region are shown in [Table 8-34](#).

The region shown in [Table 8-34](#) should encompass all the DDR2 circuitry and varies depending on placement. Non-DDR2 signals should not be routed on the DDR signal layers within the DDR2 keepout region. Non-DDR2 signals may be routed in the region, provided they are routed on layers separated from DDR2 signal layers by a ground layer. No breaks should be allowed in the reference ground layers in this region. In addition, the vdds_ddrx power plane should cover the entire keepout region. Routes for the two DDR interfaces must be separated by at least 4x; the more separation, the better.

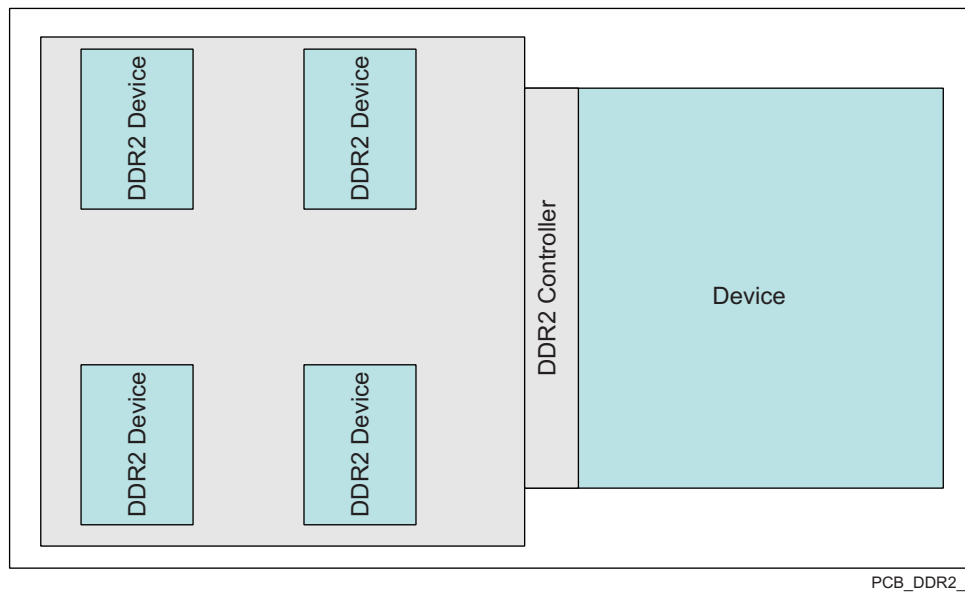

Figure 8-53. DDR2 Keepout Region

8.7.2.2.6 Bulk Bypass Capacitors

Bulk bypass capacitors are required for moderate speed bypassing of the DDR2 and other circuitry. [Table 8-35](#) contains the minimum numbers and capacitance required for the bulk bypass capacitors. Note that this table only covers the bypass needs of the DDR2 interfaces and DDR2 device. Additional bulk bypass capacitance may be needed for other circuitry.

Table 8-35. Bulk Bypass Capacitors

NO.	PARAMETER	MIN	TYP	MAX	UNIT
BC21	vdds_ddrx bulk bypass capacitor ($\geq 1\mu\text{F}$) count ⁽¹⁾		1		Devices
BC22	vdds_ddrx bulk bypass total capacitance		22		μF

(1) These devices should be placed near the devices they are bypassing, but preference should be given to the placement of the high-speed (HS) bypass capacitors and DDR2 signal routing.

8.7.2.2.7 High-Speed Bypass Capacitors

TI recommends that a PDN/power integrity analysis is performed to ensure that capacitor selection and placement is optimal for a given implementation. This section provides guidelines that can serve as a good starting point.

High-speed (HS) bypass capacitors are critical for proper DDR2 interface operation. It is particularly important to minimize the parasitic series inductance of the HS bypass capacitors, processor/DDR power, and processor/DDR ground connections. 表 8-36 contains the specification for the HS bypass capacitors as well as for the power connections on the PCB. Generally speaking, it is good to:

1. Fit as many HS bypass capacitors as possible.
2. HS bypass capacitor value is < 1µF
3. Minimize the distance from the bypass cap to the pins/balls being bypassed.
4. Use the smallest physical sized capacitors possible with the highest capacitance readily available.
5. Connect the bypass capacitor pads to their vias using the widest traces possible and using the largest hole size via possible.
6. Minimize via sharing. Note the limits on via sharing shown in 表 8-36.

表 8-36. High-Speed Bypass Capacitors

NO.	PARAMETER	MIN	TYP	MAX	UNIT
HS21	HS bypass capacitor package size ⁽¹⁾		0201	0402	10 Mils
HS22	Distance, HS bypass capacitor to processor being bypassed ⁽²⁾⁽³⁾⁽⁴⁾			400 ⁽¹²⁾	Mils
HS23	processor HS bypass capacitor count per vdds_ddrx rail ⁽¹²⁾		See 表 8-3 and ⁽¹¹⁾		Devices
HS24	processor vdds_ddrx HS bypass capacitor total capacitance ⁽¹²⁾		See 表 8-3 and ⁽¹¹⁾		µF
HS25	Number of connection vias for each device power/ground ball ⁽⁵⁾	1			Vias
HS26	Trace length from device power/ground ball to connection via ⁽²⁾		35	70	Mils
HS27	Distance, HS bypass capacitor to DDR device being bypassed ⁽⁶⁾			150	Mils
HS28	Number of connection vias for each HS capacitor ⁽⁸⁾⁽⁹⁾		4 ⁽¹⁴⁾		Vias
HS29	DDR2 device HS bypass capacitor count ⁽⁷⁾		12 ⁽¹³⁾		Devices
HS210	DDR2 device HS bypass capacitor total capacitance ⁽⁷⁾	0.85			µF
HS211	Trace length from bypass capacitor connect to connection via ⁽²⁾⁽⁹⁾		35	100	Mils
HS212	Number of connection vias for each DDR2 device power/ground ball ⁽¹⁰⁾	1			Vias
HS213	Trace length from DDR2 device power/ground ball to connection via ⁽²⁾⁽⁸⁾		35	60	Mils

- (1) LxW, 10-mil units, that is, a 0402 is a 40x20-mil surface-mount capacitor.
- (2) Closer/shorter is better.
- (3) Measured from the nearest processor power/ground ball to the center of the capacitor package.
- (4) Three of these capacitors should be located underneath the processor, between the cluster of vdds_ddrx balls and ground balls, between the DDR interfaces on the package.
- (5) See the Via Channel™ escape for the processor package.
- (6) Measured from the DDR2 device power/ground ball to the center of the capacitor package.
- (7) Per DDR2 device.
- (8) An additional HS bypass capacitor can share the connection vias only if it is mounted on the opposite side of the board. No sharing of vias is permitted on the same side of the board.
- (9) An HS bypass capacitor may share a via with a DDR device mounted on the same side of the PCB. A wide trace should be used for the connection and the length from the capacitor pad to the DDR device pad should be less than 150 mils.
- (10) Up to a total of two pairs of DDR power/ground balls may share a via.
- (11) The capacitor recommendations in this data manual reflect only the needs of this processor. Please see the memory vendor's guidelines for determining the appropriate decoupling capacitor arrangement for the memory device itself.
- (12) For more information, see 8.3, *Core Power Domains*
- (13) For more information refer to DDR2 specification.
- (14) Preferred configuration is 4 vias: 2 to power and 2 to ground.

8.7.2.2.8 Net Classes

表 8-37 lists the clock net classes for the DDR2 interface. 表 8-38 lists the signal net classes, and associated clock net classes, for the signals in the DDR2 interface. These net classes are used for the termination and routing rules that follow.

表 8-37. Clock Net Class Definitions

CLOCK NET CLASS	PIN NAMES
CK	ddrx_ck / ddrx_nck
DQS0	ddrx_dqs0 / ddrx_dqsn0
DQS1	ddrx_dqs1 / ddrx_dqsn1
DQS2 ⁽¹⁾	ddrx_dqs2 / ddrx_dqsn2
DQS3 ⁽¹⁾	ddrx_dqs3 / ddrx_dqsn3

(1) Only used on 32-bit wide DDR2 memory systems.

表 8-38. Signal Net Class Definitions

SIGNAL NET CLASS	ASSOCIATED CLOCK NET CLASS	PIN NAMES
ADDR_CTRL	CK	ddrx_ba[2:0], ddrx_a[14:0], ddrx_csnj, ddrx_casn, ddrx_rasn, ddrx_wen, ddrx_cke, ddrx_odt _i
DQ0	DQS0	ddrx_d[7:0], ddrx_dqm0
DQ1	DQS1	ddrx_d[15:8], ddrx_dqm1
DQ2 ⁽¹⁾	DQS2	ddrx_d[23:16], ddrx_dqm2
DQ3 ⁽¹⁾	DQS3	ddrx_d[31:24], ddrx_dqm3

(1) Only used on 32-bit wide DDR2 memory systems.

8.7.2.2.9 DDR2 Signal Termination

Signal terminators are required in CK and ADDR_CTRL net classes. Serial terminators may be used on data lines to reduce EMI risk; however, serial terminations are the only type permitted. ODTs are integrated on the data byte net classes. They should be enabled to ensure signal integrity. 表 8-39 shows the specifications for the series terminators.

表 8-39. DDR2 Signal Terminations

NO.	PARAMETER	MIN	TYP	MAX	UNIT
ST21	CK net class ⁽¹⁾⁽²⁾	0		10	Ω
ST22	ADDR_CTRL net class ⁽¹⁾⁽²⁾⁽³⁾⁽⁴⁾	0	22	Z _o	Ω
ST23	Data byte net classes (DQS0-DQS3, DQ0-DQ3) ⁽⁵⁾	0		Z _o	Ω

(1) Only series termination is permitted, parallel or SST specifically disallowed on board.

(2) Only required for EMI reduction.

(3) Terminator values larger than typical only recommended to address EMI issues.

(4) Termination value should be uniform across net class.

(5) No external terminations allowed for data byte net classes. ODT is to be used.

8.7.2.2.10 VREF Routing

VREF (ddrx_vref0) is used as a reference by the input buffers of the DDR2 memories as well as the processor. VREF is intended to be half the DDR2 power supply voltage and should be created using a resistive divider as shown in 图 8-51. Other methods of creating VREF are not recommended. 图 8-54 shows the layout guidelines for VREF.



图 8-54. VREF Routing and Topology

8.7.2.3 DDR2 CK and ADDR_CTRL Routing

图 8-55 shows the topology of the routing for the CK and ADDR_CTRL net classes. The route is a balanced T as it is intended that the length of segments B and C be equal. In addition, the length of A = (A' + A'') should be maximized.

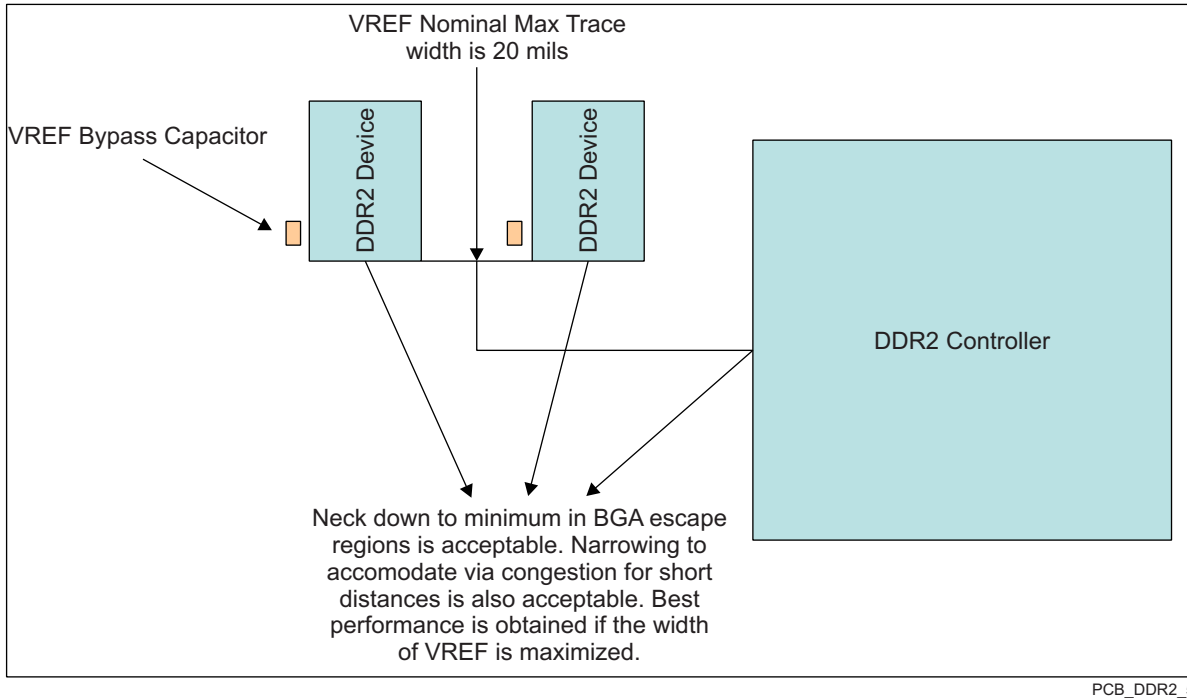

图 8-55. CK and ADDR_CTRL Routing and Topology

表 8-40. CK and ADDR_CTRL Routing Specification ⁽¹⁾

NO.	PARAMETER	MIN	MAX	UNIT
RSC21	Center-to-center ddrx_ck - ddrx_nck spacing		2w	
RSC22	ddrx_ck / ddrx_nck skew ⁽¹⁾		5	ps
RSC23	CK A-to-B/A-to-C skew mismatch ⁽²⁾		10	ps

表 8-40. CK and ADDR_CTRL Routing Specification ⁽¹⁾ (continued)

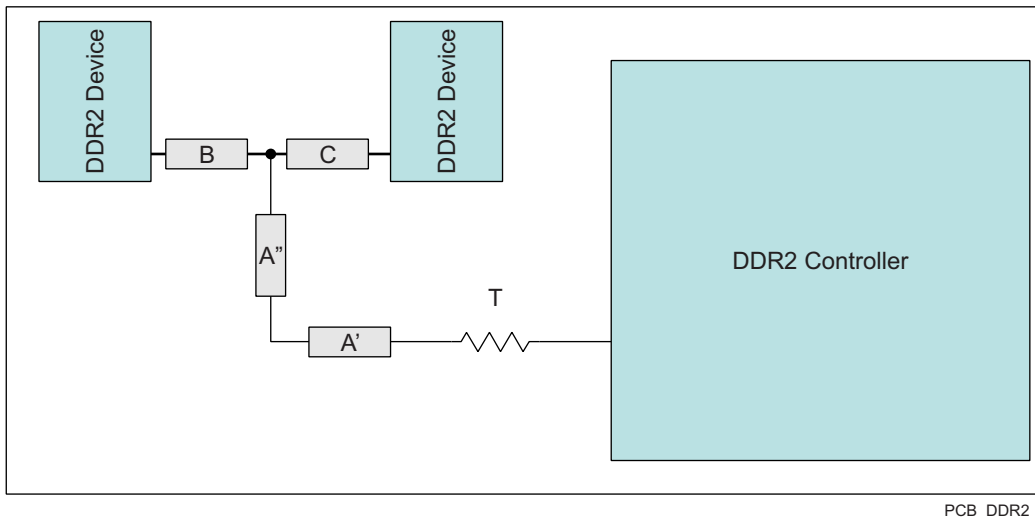
NO.	PARAMETER	MIN	MAX	UNIT
RSC24	CK B-to-C skew mismatch		10	ps
RSC25	Center-to-center CK to other DDR2 trace spacing ⁽³⁾	4w		
RSC26	CK/ADDR_CTRL trace length ⁽⁴⁾		680	ps
RSC27	ADDR_CTRL-to-CK skew mismatch		25	ps
RSC28	ADDR_CTRL-to-ADDR_CTRL skew mismatch		25	ps
RSC29	Center-to-center ADDR_CTRL to other DDR2 trace spacing ⁽³⁾	4w		
RSC210	Center-to-center ADDR_CTRL to other ADDR_CTRL trace spacing ⁽³⁾	3w		
RSC211	ADDR_CTRL A-to-B/A-to-C skew mismatch ⁽²⁾		25	ps
RSC212	ADDR_CTRL B-to-C skew mismatch		25	ps

(1) The length of segment A = A' + A'' as shown in 图 8-55.

(2) Series terminator, if used, should be located closest to the Device.

(3) Center-to-center spacing is allowed to fall to minimum 2w for up to 500 mils of routed length to accommodate BGA escape and routing congestion.

(4) This is the longest routing length of the CK and ADDR_CTRL net classes.

(5) Length of A should be maximized.

图 8-56 shows the topology and routing for the DQS and DQ net classes; the routes are point to point. Skew matching across bytes is not needed nor recommended.

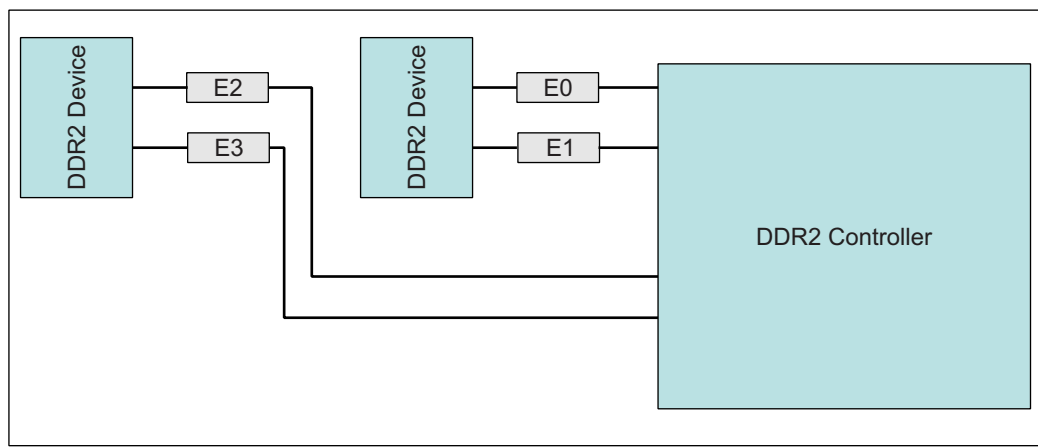

PCB_DDR2_7

图 8-56. DQS and DQ Routing and Topology

表 8-41. DQS and DQ Routing Specification

NO.	PARAMETER	MIN	MAX	UNIT
RSDQ21	Center-to-center DQS-DQSn spacing in E0 E1 E2 E3	2w		
RSDQ22	DQS-DQSn skew in E0 E1 E2 E3		5	ps
RSDQ23	Center-to-center DQS to other DDR2 trace spacing ⁽¹⁾	4w		
RSDQ24	DQS/DQ trace length ⁽²⁾⁽³⁾⁽⁴⁾		325	ps
RSDQ25	DQ-to-DQS skew mismatch ⁽²⁾⁽³⁾⁽⁴⁾		10	ps
RSDQ26	DQ-to-DQ skew mismatch ⁽²⁾⁽³⁾⁽⁴⁾		10	ps
RSDQ27	DQ-to-DQ/DQS via count mismatch ⁽²⁾⁽³⁾⁽⁴⁾		1	Vias
RSDQ28	Center-to-center DQ to other DDR2 trace spacing ⁽¹⁾⁽⁵⁾	4w		
RSDQ29	Center-to-center DQ to other DQ trace spacing ⁽¹⁾⁽⁶⁾⁽⁷⁾	3w		
RSDQ210	DQ/DQS E skew mismatch ⁽²⁾⁽³⁾⁽⁴⁾		25	ps

- (1) Center-to-center spacing is allowed to fall to minimum 2w for up to 500 mils of routed length to accommodate BGA escape and routing congestion.
- (2) A 16-bit DDR memory system has two sets of data net classes; one for data byte 0, and one for data byte 1, each with an associated DQS (2 DQSs) per DDR EMIF used.
- (3) A 32-bit DDR memory system has four sets of data net classes; one each for data bytes 0 through 3, and each associated with a DQS (4 DQSs) per DDR EMIF used.
- (4) There is no need, and it is not recommended, to skew match across data bytes; that is, from DQS0 and data byte 0 to DQS1 and data byte 1.
- (5) DQs from other DQS domains are considered *other DDR2 trace*.
- (6) DQs from other data bytes are considered *other DDR2 trace*.
- (7) This is the longest routing distance of each of the DQS and DQ net classes.

8.7.3 DDR3 Board Design and Layout Guidelines

8.7.3.1 Board Designs

TI only supports board designs using DDR3 memory that follow the guidelines in this document. The switching characteristics and timing diagram for the DDR3 memory controller are shown in 表 8-42 and 图 8-57.

表 8-42. Switching Characteristics Over Recommended Operating Conditions for DDR3 Memory Controller

NO.	PARAMETER	MIN	MAX	UNIT
1	$t_{c(DDR_CLK)}$ Cycle time, DDR_CLK	1.875	2.5 ⁽¹⁾	ns

- (1) This is the absolute maximum the clock period can be. Actual maximum clock period may be limited by DDR3 speed grade and operating frequency (see the DDR3 memory device data sheet).



图 8-57. DDR3 Memory Controller Clock Timing

8.7.3.1.1 DDR3 versus DDR2

This specification only covers device PCB designs that use DDR3 memory. Designs using DDR2 memory should use the PCB design specifications for DDR2 memory. While similar, the two memory systems have different requirements. It is currently not possible to design one PCB that covers both DDR2 and DDR3.

8.7.3.2 DDR3 EMIFs

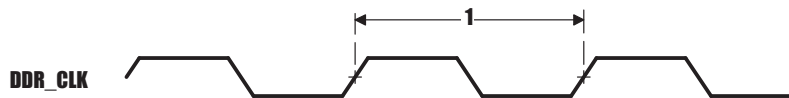
The processor contains two separate DDR3 EMIFs. This specification covers one of these EMIFs (ddr1_*) and, thus, needs to be implemented twice, once for each EMIF. The PCB layout generally turns out to be a semi-mirror with ddr2_* being a flipped version of ddr1_*; the only exception being the DDR3 devices themselves are not flipped unless mounted on opposite sides of the PCB. Requirements are identical between the two EMIFs.

8.7.3.3 DDR3 Device Combinations

Because there are several possible combinations of device counts and single- or dual-side mounting, 表 8-43 summarizes the supported device configurations.

表 8-43. Supported DDR3 Device Combinations⁽¹⁾

NUMBER OF DDR3 DEVICES	DDR3 DATA DEVICE WIDTH (BITS)	MIRRORED?	DDR3 EMIF WIDTH (BITS)
1	16	N	16

表 8-43. Supported DDR3 Device Combinations⁽¹⁾ (continued)

NUMBER OF DDR3 DEVICES	DDR3 DATA DEVICE WIDTH (BITS)	MIRRORED?	DDR3 EMIF WIDTH (BITS)
2	8	Y ⁽²⁾	16
2	16	N	32
2	16	Y ⁽²⁾	32
3	16	N ⁽⁴⁾	32
4	8	N	32
4	8	Y ⁽³⁾	32
5	8	N ⁽⁴⁾	32

(1) This table is per EMIF.

(2) Two DDR3 devices are mirrored when one device is placed on the top of the board and the second device is placed on the bottom of the board.

(3) This is two mirrored pairs of DDR3 devices.

(4) The DDR memory connected to the DDR ECC bus does NOT need to be the same part number as the DDR memories connected to the DDR data bus. However, some constraints do apply. When selecting a memory for the DDR ECC bus, the following restrictions must be adhered to as compared to the DDR memories on the data bus:

- Match the same DDR3 speed grade
- Have an equal number of internal banks
- Have an equal number of columns
- Have a greater or equal number of rows

8.7.3.4 DDR3 Interface Schematic

8.7.3.4.1 32-Bit DDR3 Interface

The DDR3 interface schematic varies, depending upon the width of the DDR3 devices used and the width of the bus used (16 or 32 bits). General connectivity is straightforward and very similar. 16-bit DDR devices look like two 8-bit devices. [☒ 8-58](#) and [☒ 8-59](#) show the schematic connections for 32-bit interfaces using x16 devices.

8.7.3.4.2 16-Bit DDR3 Interface

Note that the 16-bit wide interface schematic is practically identical to the 32-bit interface (see [☒ 8-58](#) and [☒ 8-59](#)); only the high-word DDR memories are removed and the unused DQS inputs are tied off.

When not using all of part of a DDR interface, the proper method of handling the unused pins is to tie off the `ddrx_dqsi` pins to ground via a 1k-Ω resistor and to tie off the `ddrx_dqsni` pins to the corresponding `vdds_ddrx` supply via a 1k-Ω resistor. This needs to be done for each byte not used. Although these signals have internal pullups and pulldowns, external pullups and pulldowns provide additional protection against external electrical noise causing activity on the signals.

The `vdds_ddrx` and `ddrx_vref0` power supply pins need to be connected to their respective power supplies even if `ddrx` is not being used. All other DDR interface pins can be left unconnected. Note that the supported modes for use of the DDR EMIF are 32-bits wide, 16-bits wide, or not used.

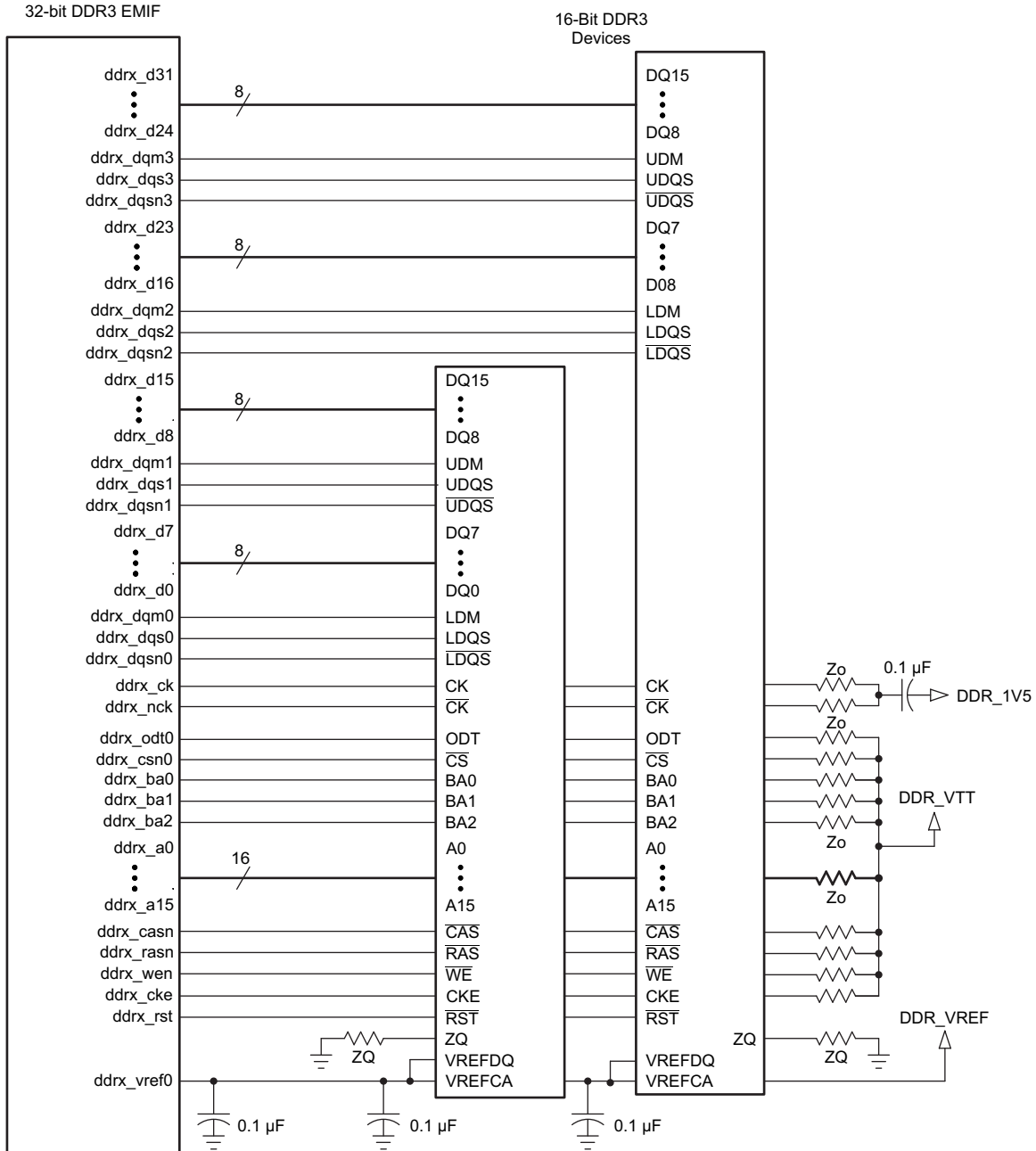

Z_o
 —∧∧∧— Termination is required. See terminator comments.

Z_Q
 —∧∧∧— Value determined according to the DDR memory device data sheet.

VAYU_PCB_DDR3_1

8-58. 32-Bit, One-Bank DDR3 Interface Schematic Using Two 16-Bit DDR3 Devices

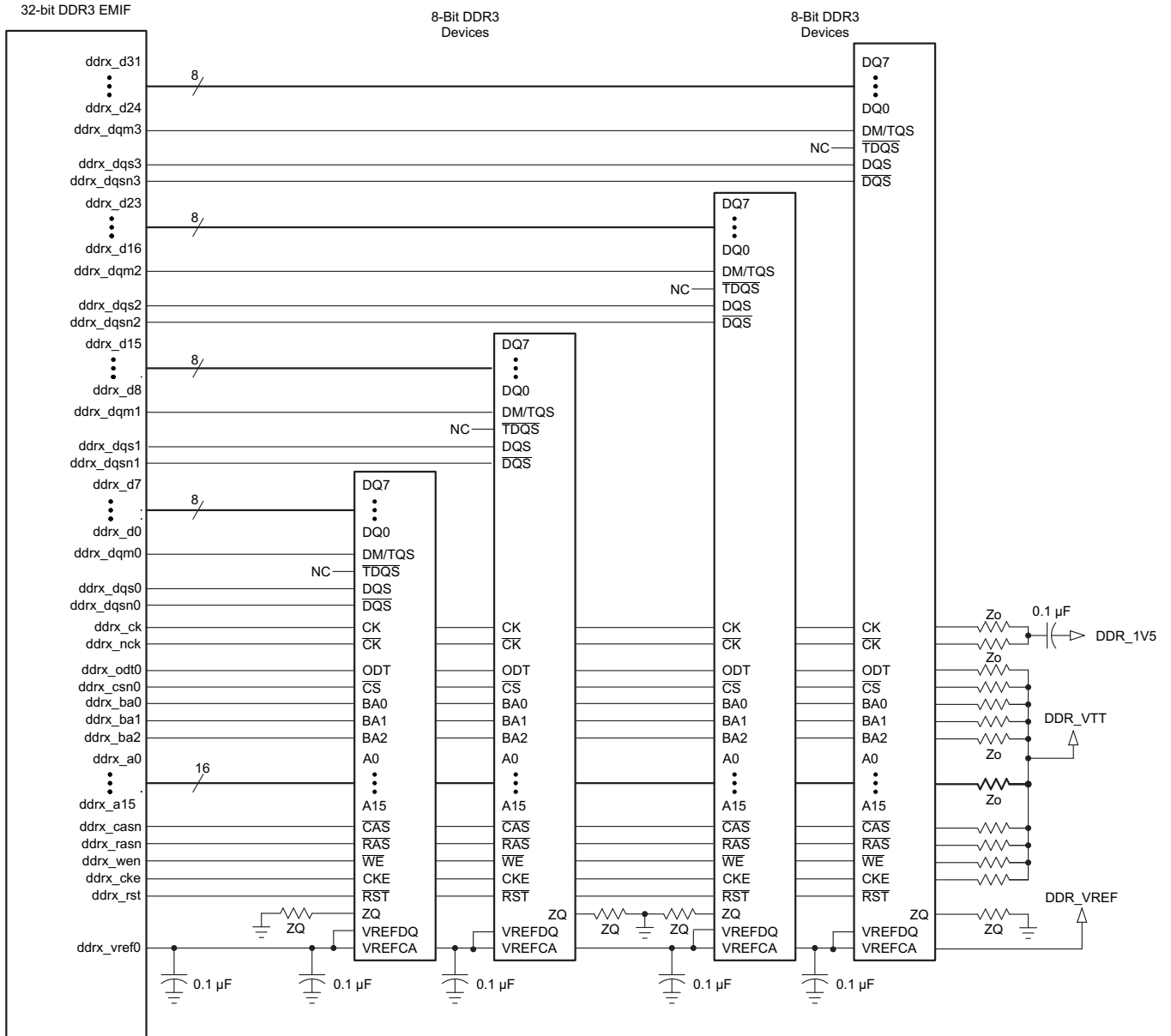

Z_o Termination is required. See terminator comments.
 Z_Q Value determined according to the DDR memory device data sheet.

8-59. 32-Bit, One-Bank DDR3 Interface Schematic Using Four 8-Bit DDR3 Devices

8.7.3.5 Compatible JEDEC DDR3 Devices

表 8-44 shows the parameters of the JEDEC DDR3 devices that are compatible with this interface. Generally, the DDR3 interface is compatible with DDR3-1066 devices in the x8 or x16 widths.

表 8-44. Compatible JEDEC DDR3 Devices (Per Interface)

N O.	PARAMETER	CONDITION	MIN	MAX	UNIT
1	JEDEC DDR3 device speed grade ⁽¹⁾	DDR clock rate = 400MHz	DDR3-800	DDR3-1600	
		400MHz < DDR clock rate ≤ 533MHz	DDR3-1066	DDR3-1600	
2	JEDEC DDR3 device bit width		x8	x16	Bits
3	JEDEC DDR3 device count ⁽²⁾		2	4	Devices

(1) Refer to 表 8-42 Switching Characteristics Over Recommended Operating Conditions for DDR3 Memory Controller for the range of supported DDR clock rates.

(2) For valid DDR3 device configurations and device counts, see 8.7.3.4, 图 8-58, and 图 8-59.

8.7.3.6 PCB Stackup

The minimum stackup for routing the DDR3 interface is a six-layer stack up as shown in 表 8-45. Additional layers may be added to the PCB stackup to accommodate other circuitry, enhance SI/EMI performance, or to reduce the size of the PCB footprint. Complete stackup specifications are provided in 表 8-46.

表 8-45. Six-Layer PCB Stackup Suggestion

LAYER	TYPE	DESCRIPTION
1	Signal	Top routing mostly vertical
2	Plane	Ground
3	Plane	Split power plane
4	Plane	Split power plane or Internal routing
5	Plane	Ground
6	Signal	Bottom routing mostly horizontal

表 8-46. PCB Stackup Specifications

NO.	PARAMETER	MIN	TYP	MAX	UNIT
PS1	PCB routing/plane layers	6			
PS2	Signal routing layers	3			
PS3	Full ground reference layers under DDR3 routing region ⁽¹⁾	1			
PS4	Full 1.5-V power reference layers under the DDR3 routing region ⁽¹⁾	1			
PS5	Number of reference plane cuts allowed within DDR routing region ⁽²⁾			0	
PS6	Number of layers between DDR3 routing layer and reference plane ⁽³⁾			0	
PS7	PCB routing feature size		4		Mils
PS8	PCB trace width, w		4		Mils
PS9	Single-ended impedance, Z ₀	50		75	Ω
PS10	Impedance control ⁽⁵⁾	Z-5	Z	Z+5	Ω

- (1) Ground reference layers are preferred over power reference layers. Be sure to include bypass caps to accommodate reference layer return current as the trace routes switch routing layers.
- (2) No traces should cross reference plane cuts within the DDR routing region. High-speed signal traces crossing reference plane cuts create large return current paths which can lead to excessive crosstalk and EMI radiation.
- (3) Reference planes are to be directly adjacent to the signal plane to minimize the size of the return current loop.
- (4) An 18-mil pad assumes Via Channel is the most economical BGA escape. A 20-mil pad may be used if additional layers are available for power routing. An 18-mil pad is required for minimum layer count escape.
- (5) Z is the nominal singled-ended impedance selected for the PCB specified by PS9.

8.7.3.7 Placement

☒ 8-60 shows the required placement for the processor as well as the DDR3 devices. The dimensions for this figure are defined in 表 8-47. The placement does not restrict the side of the PCB on which the devices are mounted. The ultimate purpose of the placement is to limit the maximum trace lengths and allow for proper routing space. For a 16-bit DDR memory system, the high-word DDR3 devices are omitted from the placement.

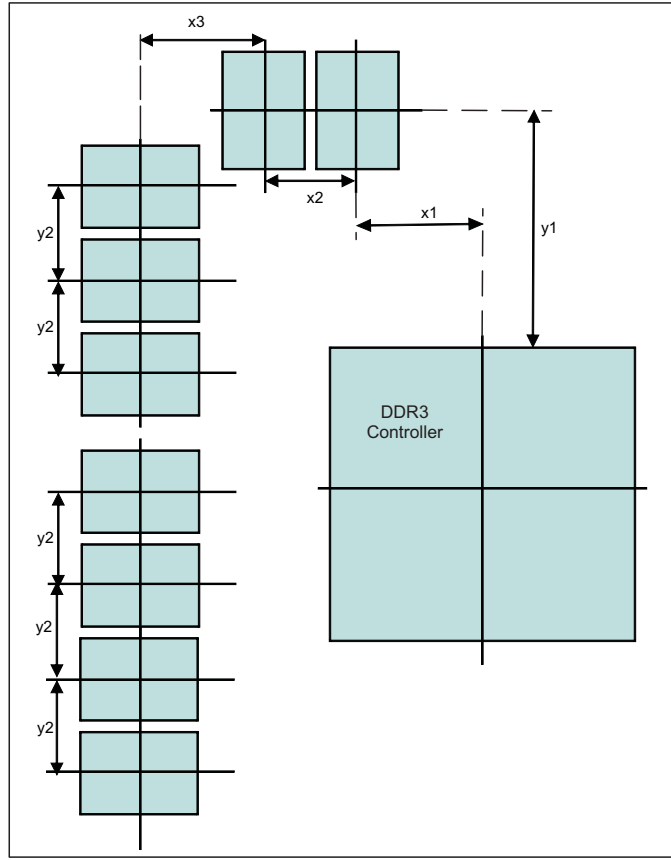

PCB_DDR3_3

图 8-60. Placement Specifications

表 8-47. Placement Specifications DDR3

NO.	PARAMETER	MIN	MAX	UNIT
KOD31	X1		500	Mils
KOD32	X2		600	Mils
KOD33	X3		600	Mils
KOD34	Y1		1800	Mils
KOD35	Y2		600	Mils
KOD36	DDR3 keepout region ⁽¹⁾			
KOD37	Clearance from non-DDR3 signal to DDR3 keepout region ^{(2) (3)}	4		W

- (1) DDR3 keepout region to encompass entire DDR3 routing area.
- (2) Non-DDR3 signals allowed within DDR3 keepout region provided they are separated from DDR3 routing layers by a ground plane.
- (3) If a device has more than one DDR controller, the signals from the other controller(s) are considered non-DDR3 and should be separated by this specification.

8.7.3.8 DDR3 Keepout Region

The region of the PCB used for DDR3 circuitry must be isolated from other signals. The DDR3 keepout region is defined for this purpose and is shown in [Figure 8-61](#). The size of this region varies with the placement and DDR routing. Additional clearances required for the keepout region are shown in [Table 8-47](#). Non-DDR3 signals should not be routed on the DDR signal layers within the DDR3 keepout region. Non-DDR3 signals may be routed in the region, provided they are routed on layers separated from the DDR signal layers by a ground layer. No breaks should be allowed in the reference ground layers in this region. In addition, the 1.5-V DDR3 power plane should cover the entire keepout region. Also note that the two signals from the DDR3 controller should be separated from each other by the specification in [Table 8-47](#), (see [KOD37](#)).

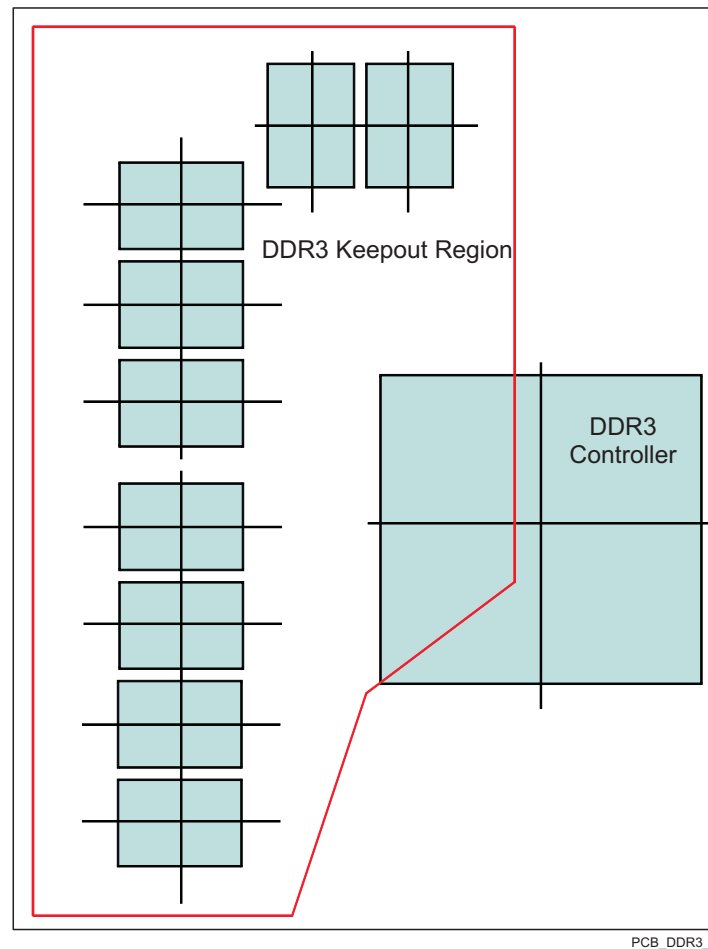

Figure 8-61. DDR3 Keepout Region

8.7.3.9 Bulk Bypass Capacitors

Bulk bypass capacitors are required for moderate speed bypassing of the DDR3 and other circuitry. [Table 8-48](#) contains the minimum numbers and capacitance required for the bulk bypass capacitors. Note that this table only covers the bypass needs of the DDR3 controllers and DDR3 devices. Additional bulk bypass capacitance may be needed for other circuitry.

表 8-48. Bulk Bypass Capacitors

NO.	PARAMETER	MIN	MAX	UNIT
1	vdds_ddrx bulk bypass capacitor count ⁽¹⁾	1		Devices
2	vdds_ddrx bulk bypass total capacitance	22		μF

(1) These devices should be placed near the devices they are bypassing, but preference should be given to the placement of the high-speed (HS) bypass capacitors and DDR3 signal routing.

8.7.3.10 High-Speed Bypass Capacitors

High-speed (HS) bypass capacitors are critical for proper DDR3 interface operation. It is particularly important to minimize the parasitic series inductance of the HS bypass capacitors, processor/DDR power, and processor/DDR ground connections. 表 8-49 contains the specification for the HS bypass capacitors as well as for the power connections on the PCB. Generally speaking, it is good to:

1. Fit as many HS bypass capacitors as possible.
2. Minimize the distance from the bypass cap to the pins/balls being bypassed.
3. Use the smallest physical sized capacitors possible with the highest capacitance readily available.
4. Connect the bypass capacitor pads to their vias using the widest traces possible and using the largest hole size via possible.
5. Minimize via sharing. Note the limites on via sharing shown in 表 8-49.

表 8-49. High-Speed Bypass Capacitors

NO.	PARAMETER	MIN	TYP	MAX	UNIT
1	HS bypass capacitor package size ⁽¹⁾		0201	0402	10 Mils
2	Distance, HS bypass capacitor to processor being bypassed ⁽²⁾⁽³⁾⁽⁴⁾			400	Mils
3	processor HS bypass capacitor count per vdds_ddrx rail ⁽¹²⁾		See 表 8-3 and ⁽¹¹⁾		Devices
4	processor HS bypass capacitor total capacitance per vdds_ddrx rail ⁽¹²⁾		See 表 8-3 and ⁽¹¹⁾		μF
5	Number of connection vias for each device power/ground ball ⁽⁵⁾				Vias
6	Trace length from device power/ground ball to connection via ⁽²⁾		35	70	Mils
7	Distance, HS bypass capacitor to DDR device being bypassed ⁽⁶⁾			150	Mils
8	DDR3 device HS bypass capacitor count ⁽⁷⁾	12			Devices
9	DDR3 device HS bypass capacitor total capacitance ⁽⁷⁾	0.85			μF
10	Number of connection vias for each HS capacitor ⁽⁸⁾⁽⁹⁾	2			Vias
11	Trace length from bypass capacitor connect to connection via ⁽²⁾⁽⁹⁾		35	100	Mils
12	Number of connection vias for each DDR3 device power/ground ball ⁽¹⁰⁾	1			Vias
13	Trace length from DDR3 device power/ground ball to connection via ⁽²⁾⁽⁸⁾		35	60	Mils

(1) LxW, 10-mil units, that is, a 0402 is a 40x20-mil surface-mount capacitor.

(2) Closer/shorter is better.

(3) Measured from the nearest processor power/ground ball to the center of the capacitor package.

(4) Three of these capacitors should be located underneath the processor, between the cluster of DDR_1V5 balls and ground balls, between the DDR interfaces on the package.

(5) See the Via Channel™ escape for the processor package.

(6) Measured from the DDR3 device power/ground ball to the center of the capacitor package.

(7) Per DDR3 device.

(8) An additional HS bypass capacitor can share the connection vias only if it is mounted on the opposite side of the board. No sharing of vias is permitted on the same side of the board.

(9) An HS bypass capacitor may share a via with a DDR device mounted on the same side of the PCB. A wide trace should be used for the connection and the length from the capacitor pad to the DDR device pad should be less than 150 mils.

(10) Up to a total of two pairs of DDR power/ground balls may share a via.

(11) The capacitor recommendations in this data manual reflect only the needs of this processor. Please see the memory vendor's guidelines for determining the appropriate decoupling capacitor arrangement for the memory device itself.

(12) For more information, see 8.3, *Core Power Domains*

8.7.3.10.1 Return Current Bypass Capacitors

Use additional bypass capacitors if the return current reference plane changes due to DDR3 signals hopping from one signal layer to another. The bypass capacitor here provides a path for the return current to hop planes along with the signal. As many of these return current bypass capacitors should be used as possible. Because these are returns for signal current, the signal via size may be used for these capacitors.

8.7.3.11 Net Classes

表 8-50 lists the clock net classes for the DDR3 interface. 表 8-51 lists the signal net classes, and associated clock net classes, for signals in the DDR3 interface. These net classes are used for the termination and routing rules that follow.

表 8-50. Clock Net Class Definitions

CLOCK NET CLASS	processor PIN NAMES
CK	ddrx_ck/ddrx_nck
DQS0	ddrx_dqs0 / ddrx_dqsn0
DQS1	ddrx_dqs1 / ddrx_dqsn1
DQS2 ⁽¹⁾	ddrx_dqs2 / ddrx_dqsn2
DQS3 ⁽¹⁾	ddrx_dqs3 / ddrx_dqsn3

(1) Only used on 32-bit wide DDR3 memory systems.

表 8-51. Signal Net Class Definitions

SIGNAL NET CLASS	ASSOCIATED CLOCK NET CLASS	processor PIN NAMES
ADDR_CTRL	CK	ddrx_ba[2:0], ddrx_a[14:0], ddrx_csnj, ddrx_casn, ddrx_rasn, ddrx_wen, ddrx_cke, ddrx_odti
DQ0	DQS0	ddrx_d[7:0], ddrx_dqm0
DQ1	DQS1	ddrx_d[15:8], ddrx_dqm1
DQ2 ⁽¹⁾	DQS2	ddrx_d[23:16], ddrx_dqm2
DQ3 ⁽¹⁾	DQS3	ddrx_d[31:24], ddrx_dqm3

(1) Only used on 32-bit wide DDR3 memory systems.

8.7.3.12 DDR3 Signal Termination

Signal terminators are required for the CK and ADDR_CTRL net classes. The data lines are terminated by ODT and, thus, the PCB traces should be unterminated. Detailed termination specifications are covered in the routing rules in the following sections.

8.7.3.13 VREF_DDR Routing

ddrx_vref0 (VREF) is used as a reference by the input buffers of the DDR3 memories as well as the processor. VREF is intended to be half the DDR3 power supply voltage and is typically generated with the DDR3 VDD5 and VTT power supply. It should be routed as a nominal 20-mil wide trace with 0.1 μ F bypass capacitors near each device connection. Narrowing of VREF is allowed to accommodate routing congestion.

8.7.3.14 VTT

Like VREF, the nominal value of the VTT supply is half the DDR3 supply voltage. Unlike VREF, VTT is expected to source and sink current, specifically the termination current for the ADDR_CTRL net class Thevenin terminators. VTT is needed at the end of the address bus and it should be routed as a power sub-plane. VTT should be bypassed near the terminator resistors.

8.7.3.15 CK and ADDR_CTRL Topologies and Routing Definition

The CK and ADDR_CTRL net classes are routed in a fly-by topology. They are routed in a similar manner and are length matched to minimize skew between them. CK is a bit more complicated because it runs at a higher transition rate and is differential. The following subsections show the topology and routing for various DDR3 configurations for CK and ADDR_CTRL. The figures in the following subsections define the terms for the routing specification detailed in 表 8-52. Balanced-T routing is not recommended.

8.7.3.15.1 Four DDR3 Devices

Four DDR3 devices are supported on the DDR EMIF consisting of four x8 DDR3 devices arranged as one bank (CS). These four devices may be mounted on a single side of the PCB, or may be mirrored in two pairs to save board space at a cost of increased routing complexity and parts on the backside of the PCB.

8.7.3.15.1.1 CK and ADDR_CTRL Topologies, Four DDR3 Devices

图 8-62 shows the topology of the CK net classes and 图 8-63 shows the topology for the corresponding ADDR_CTRL net classes.



图 8-62. CK Topology for Four x8 DDR3 Devices



图 8-63. ADDR_CTRL Topology for Four x8 DDR3 Devices

8.7.3.15.1.2 CK and ADDR_CTRL Routing, Four DDR3 Devices

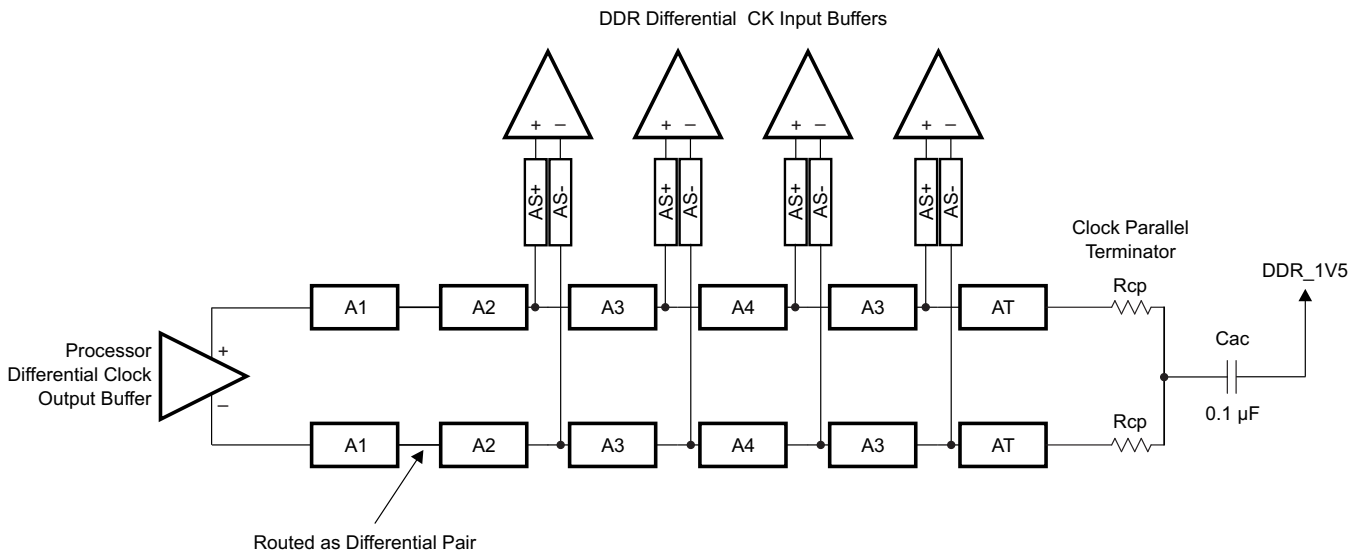
图 8-64 shows the CK routing for four DDR3 devices placed on the same side of the PCB. 图 8-65 shows the corresponding ADDR_CTRL routing.

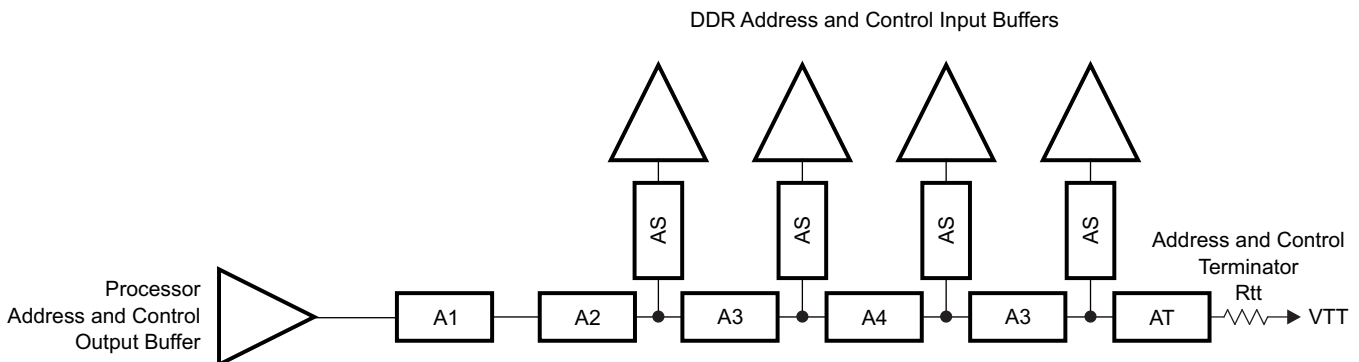
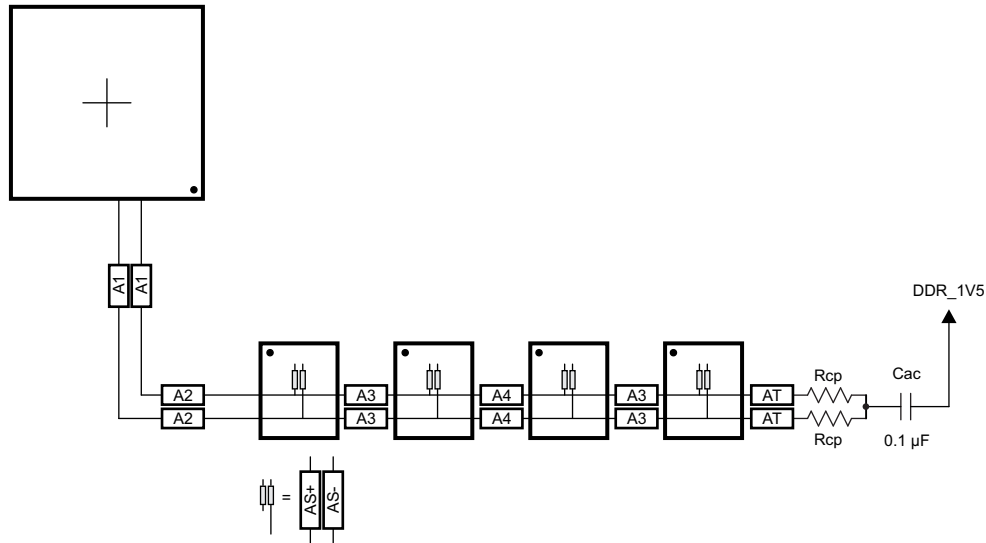

8-64. CK Routing for Four Single-Side DDR3 Devices

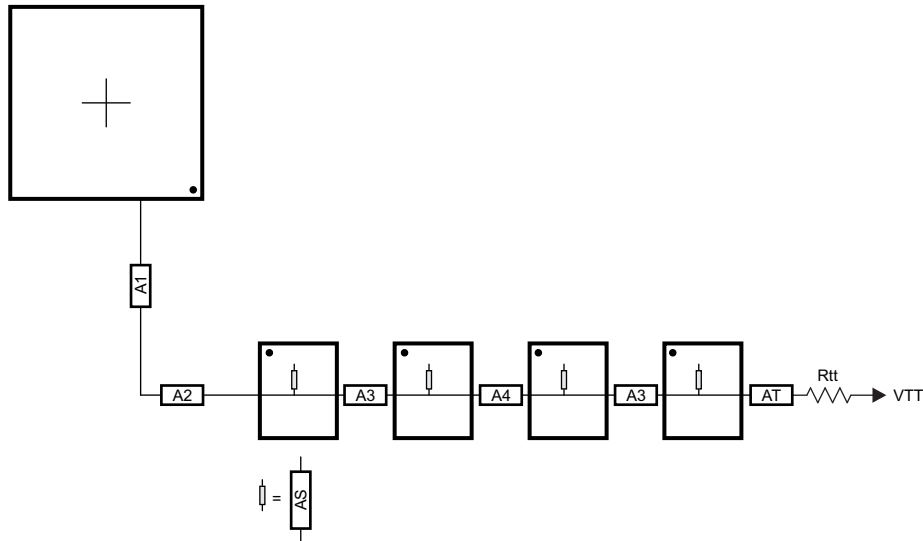

8-65. ADDR_CTRL Routing for Four Single-Side DDR3 Devices

To save PCB space, the four DDR3 memories may be mounted as two mirrored pairs at a cost of increased routing and assembly complexity. 8-66 and 8-67 show the routing for CK and ADDR_CTRL, respectively, for four DDR3 devices mirrored in a two-pair configuration.

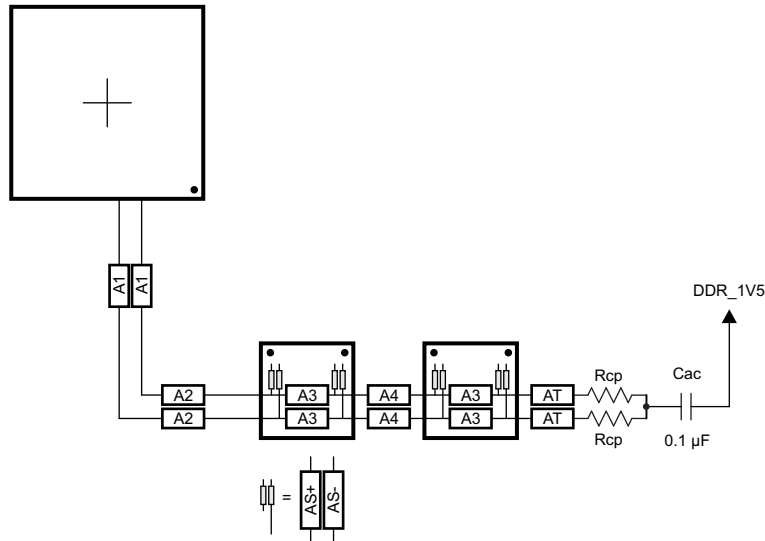

✎ 8-66. CK Routing for Four Mirrored DDR3 Devices

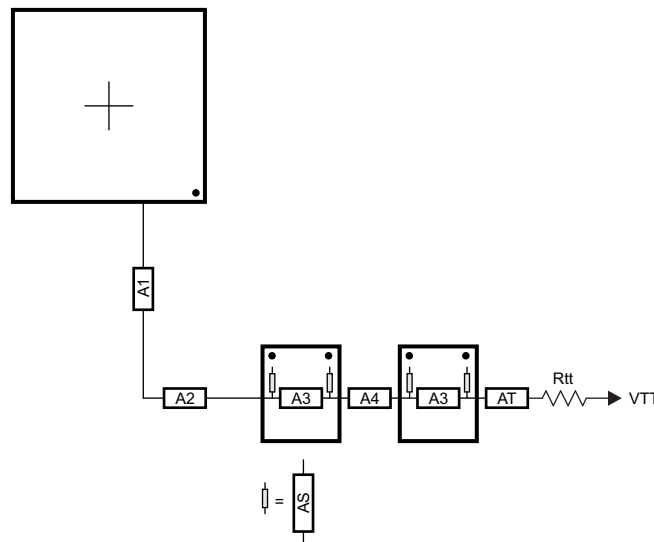

✎ 8-67. ADDR_CTRL Routing for Four Mirrored DDR3 Devices

8.7.3.15.2 Two DDR3 Devices

Two DDR3 devices are supported on the DDR EMIF consisting of two x8 DDR3 devices arranged as one bank (CS), 16 bits wide, or two x16 DDR3 devices arranged as one bank (CS), 32 bits wide. These two devices may be mounted on a single side of the PCB, or may be mirrored in a pair to save board space at a cost of increased routing complexity and parts on the backside of the PCB.

8.7.3.15.2.1 CK and ADDR_CTRL Topologies, Two DDR3 Devices

✎ 8-68 shows the topology of the CK net classes and ✎ 8-69 shows the topology for the corresponding ADDR_CTRL net classes.

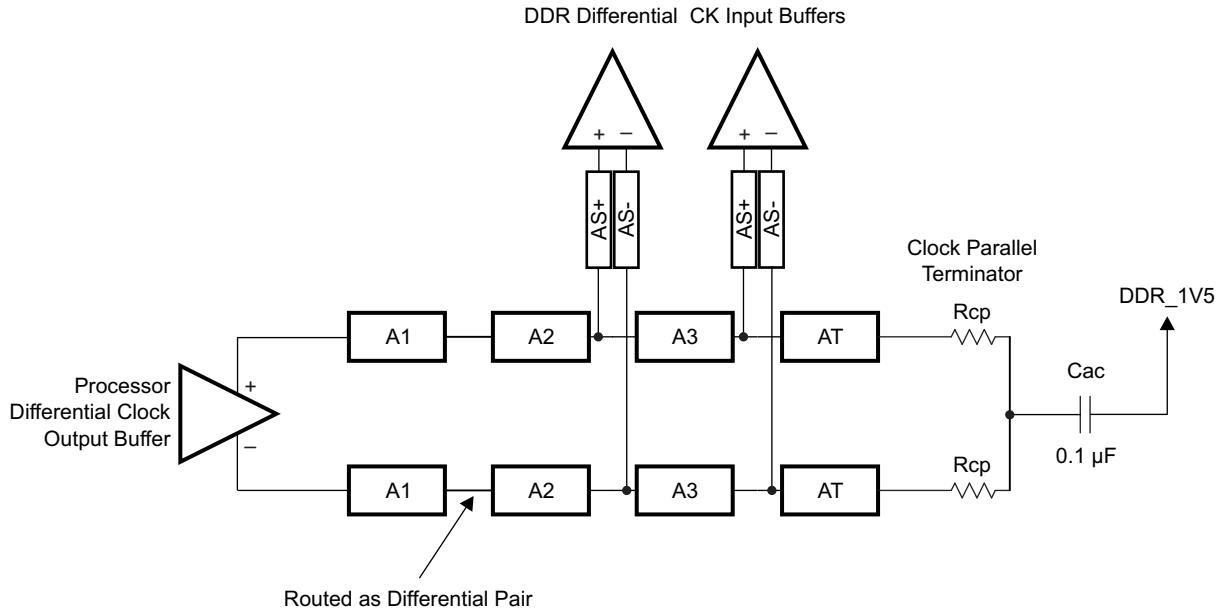

8-68. CK Topology for Two DDR3 Devices

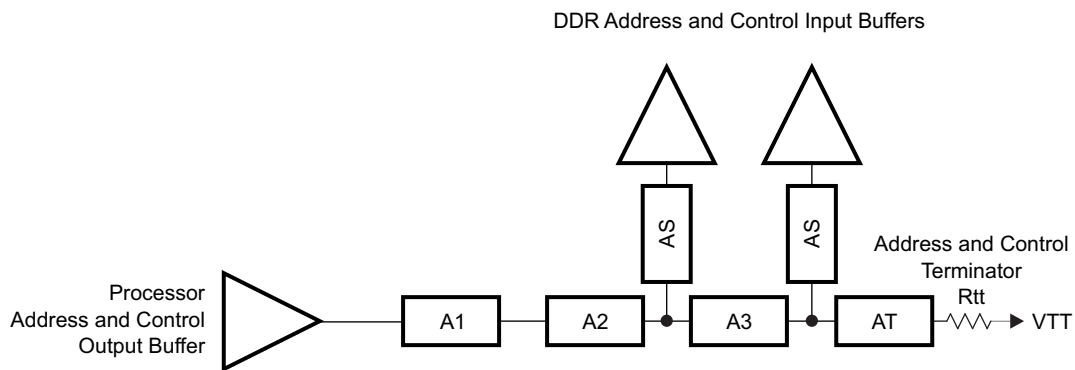

8-69. ADDR_CTRL Topology for Two DDR3 Devices

8.7.3.15.2.2 CK and ADDR_CTRL Routing, Two DDR3 Devices

8-70 shows the CK routing for two DDR3 devices placed on the same side of the PCB. 8-71 shows the corresponding ADDR_CTRL routing.

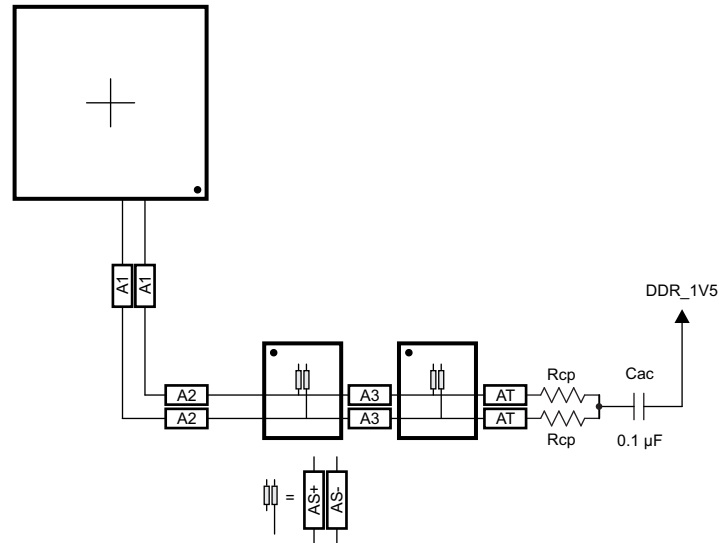

✎ 8-70. CK Routing for Two Single-Side DDR3 Devices

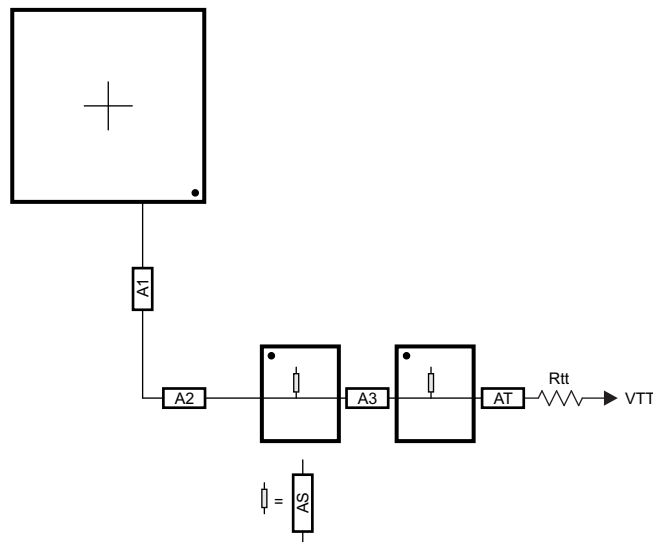

✎ 8-71. ADDR_CTRL Routing for Two Single-Side DDR3 Devices

To save PCB space, the two DDR3 memories may be mounted as a mirrored pair at a cost of increased routing and assembly complexity. ✎ 8-72 and ✎ 8-73 show the routing for CK and ADDR_CTRL, respectively, for two DDR3 devices mirrored in a single-pair configuration.

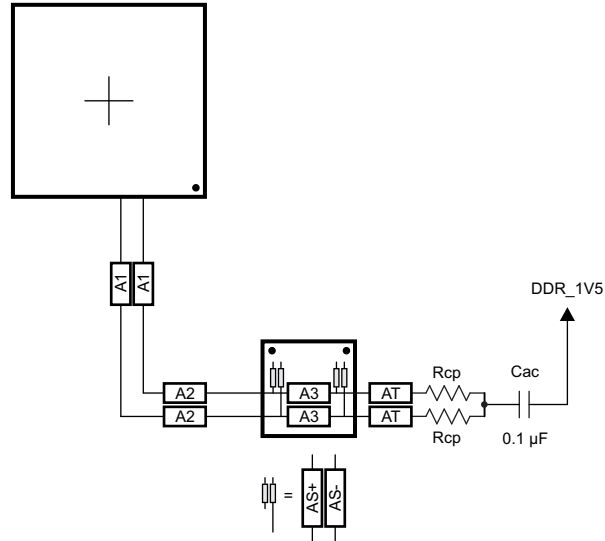

☒ 8-72. CK Routing for Two Mirrored DDR3 Devices

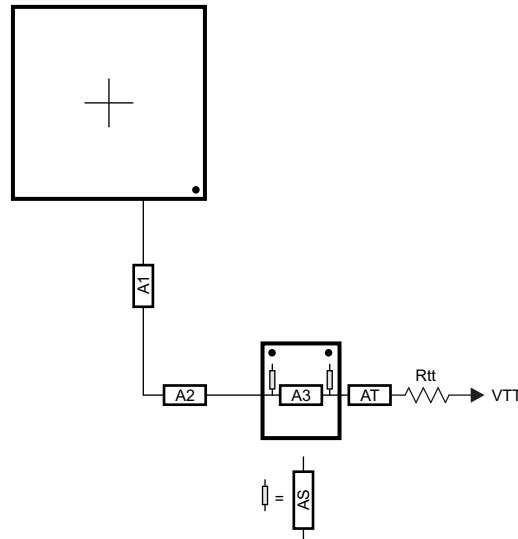

☒ 8-73. ADDR_CTRL Routing for Two Mirrored DDR3 Devices

8.7.3.15.3 One DDR3 Device

A single DDR3 device is supported on the DDR EMIF consisting of one x16 DDR3 device arranged as one bank (CS), 16 bits wide.

8.7.3.15.3.1 CK and ADDR_CTRL Topologies, One DDR3 Device

☒ 8-74 shows the topology of the CK net classes and ☒ 8-75 shows the topology for the corresponding ADDR_CTRL net classes.

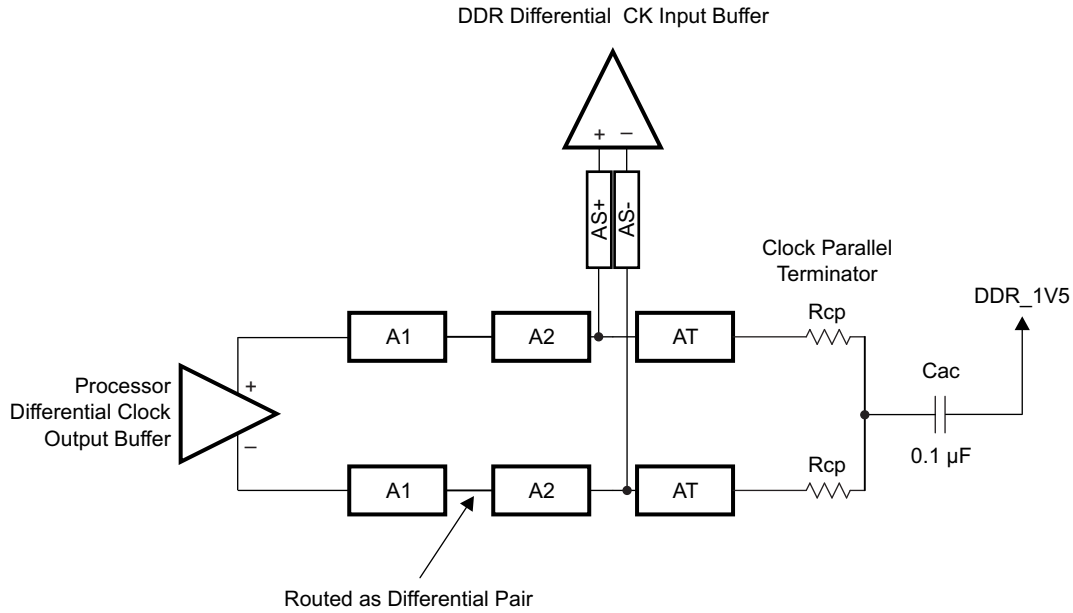

☒ 8-74. CK Topology for One DDR3 Device

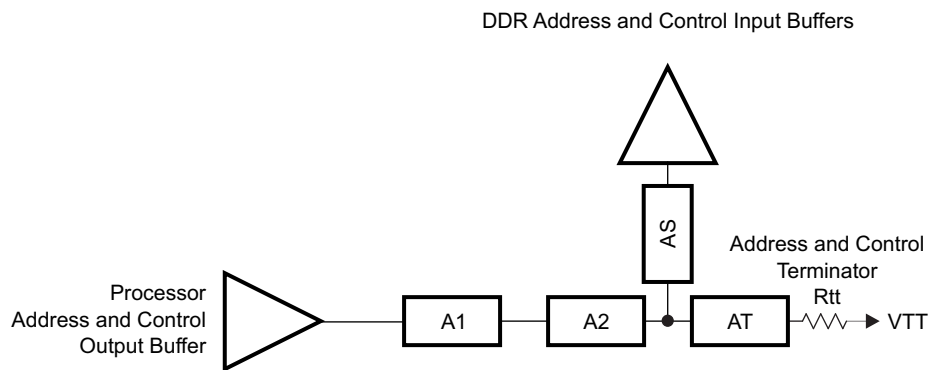

☒ 8-75. ADDR_CTRL Topology for One DDR3 Device

8.7.3.15.3.2 CK and ADDR/CTRL Routing, One DDR3 Device

☒ 8-76 shows the CK routing for one DDR3 device placed on the same side of the PCB. ☒ 8-77 shows the corresponding ADDR_CTRL routing.

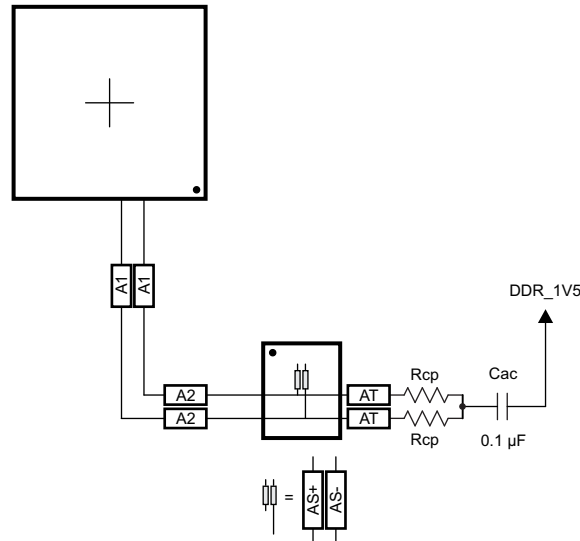

✎ 8-76. CK Routing for One DDR3 Device

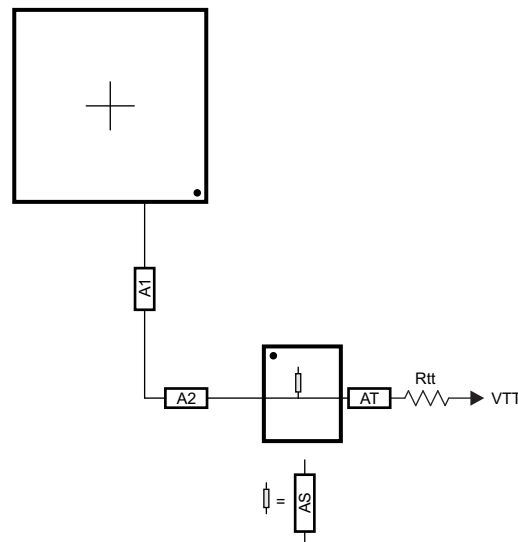

✎ 8-77. ADDR_CTRL Routing for One DDR3 Device

8.7.3.16 Data Topologies and Routing Definition

No matter the number of DDR3 devices used, the data line topology is always point to point, so its definition is simple.

Care should be taken to minimize layer transitions during routing. If a layer transition is necessary, it is better to transition to a layer using the same reference plane. If this cannot be accommodated, ensure there are nearby ground vias to allow the return currents to transition between reference planes if both reference planes are ground or vdds_dds. Ensure there are nearby bypass capacitors to allow the return currents to transition between reference planes if one of the reference planes is ground. The goal is to minimize the size of the return current loops.

8.7.3.16.1 DQS and DQ/DM Topologies, Any Number of Allowed DDR3 Devices

DQS lines are point-to-point differential, and DQ/DM lines are point-to-point singled ended. ✎ 8-78 and ✎ 8-79 show these topologies.

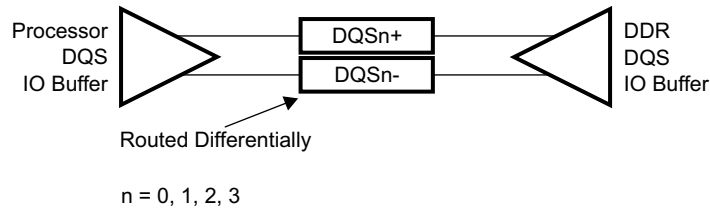

8-78. DQS Topology

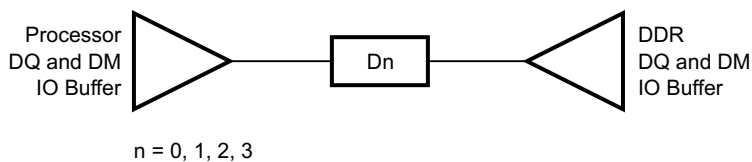

8-79. DQ/DM Topology

8.7.3.16.2 DQS and DQ/DM Routing, Any Number of Allowed DDR3 Devices

8-80 and 8-81 show the DQS and DQ/DM routing.

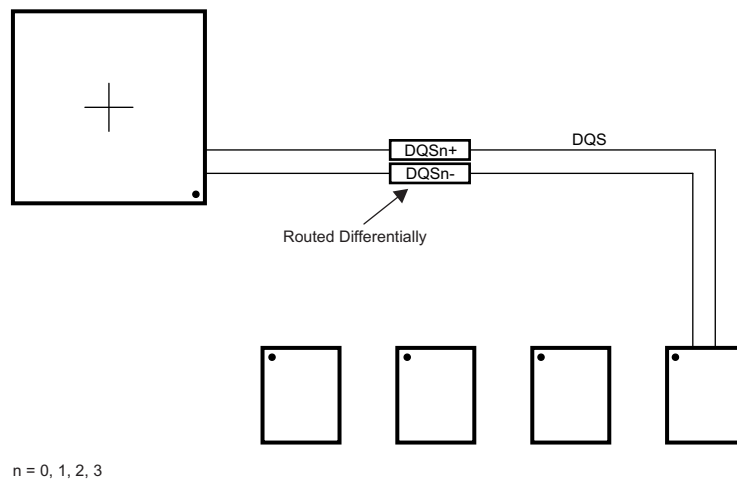

8-80. DQS Routing With Any Number of Allowed DDR3 Devices

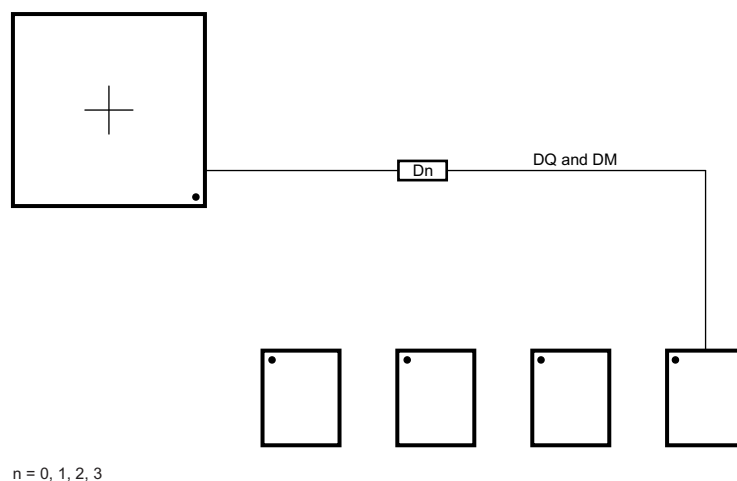

8-81. DQ/DM Routing With Any Number of Allowed DDR3 Devices

8.7.3.17 Routing Specification

8.7.3.17.1 CK and ADDR_CTRL Routing Specification

Skew within the CK and ADDR_CTRL net classes directly reduces setup and hold margin and, thus, this skew must be controlled. The only way to practically match lengths on a PCB is to lengthen the shorter traces up to the length of the longest net in the net class and its associated clock. A metric to establish this maximum length is Manhattan distance. The Manhattan distance between two points on a PCB is the length between the points when connecting them only with horizontal or vertical segments. A reasonable trace route length is to within a percentage of its Manhattan distance. CACLM is defined as Clock Address Control Longest Manhattan distance.

Given the clock and address pin locations on the processor and the DDR3 memories, the maximum possible Manhattan distance can be determined given the placement. [Figure 8-82](#) and [Figure 8-83](#) show this distance for four loads and two loads, respectively. It is from this distance that the specifications on the lengths of the transmission lines for the address bus are determined. CACLM is determined similarly for other address bus configurations; that is, it is based on the longest net of the CK/ADDR_CTRL net class. For CK and ADDR_CTRL routing, these specifications are contained in [Table 8-52](#).

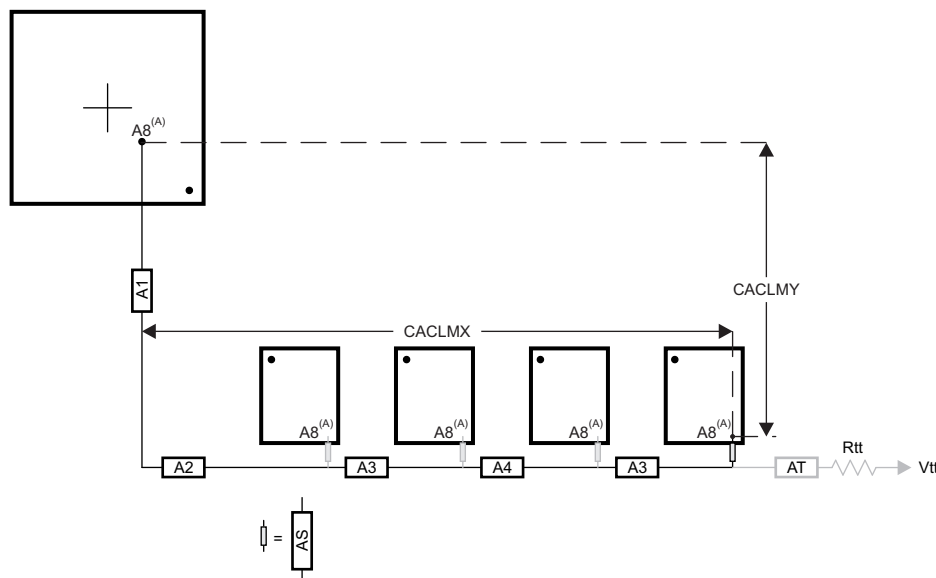

- A. It is very likely that the longest CK/ADDR_CTRL Manhattan distance will be for Address Input 8 (A8) on the DDR3 memories. CACLM is based on the longest Manhattan distance due to the device placement. Verify the net class that satisfies this criteria and use as the baseline for CK/ADDR_CTRL skew matching and length control. The length of shorter CK/ADDR_CTRL stubs as well as the length of the terminator stub are not included in this length calculation. Non-included lengths are grayed out in the figure. Assuming A8 is the longest, CALM = CACLMY + CACLMX + 300 mils. The extra 300 mils allows for routing down lower than the DDR3 memories and returning up to reach A8.

Figure 8-82. CACLM for Four Address Loads on One Side of PCB

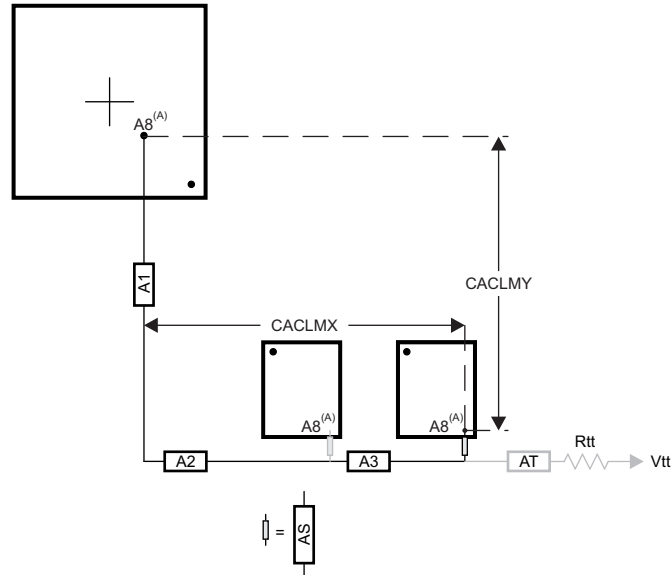

- A. It is very likely that the longest CK/ADDR_CTRL Manhattan distance will be for Address Input 8 (A8) on the DDR3 memories. CACLM is based on the longest Manhattan distance due to the device placement. Verify the net class that satisfies this criteria and use as the baseline for CK/ADDR_CTRL skew matching and length control.

The length of shorter CK/ADDR_CTRL stubs as well as the length of the terminator stub are not included in this length calculation. Non-included lengths are grayed out in the figure.

Assuming A8 is the longest, CALM = CACLMY + CACLMX + 300 mils.

The extra 300 mils allows for routing down lower than the DDR3 memories and returning up to reach A8.

图 8-83. CACLM for Two Address Loads on One Side of PCB

表 8-52. CK and ADDR_CTRL Routing Specification⁽²⁾⁽³⁾

NO.	PARAMETER	MIN	TYP	MAX	UNIT
CARS31	A1+A2 length			500 ⁽¹⁾	ps
CARS32	A1+A2 skew			29	ps
CARS33	A3 length			125	ps
CARS34	A3 skew ⁽⁴⁾			6	ps
CARS35	A3 skew ⁽⁵⁾			6	ps
CARS36	A4 length			125	ps
CARS37	A4 skew			6	ps
CARS38	AS length		5 ⁽¹⁾	17	ps
CARS39	AS skew		1.3 ⁽¹⁾	14	ps
CARS310	AS+/AS- length		5	12	ps
CARS311	AS+/AS- skew			1	ps
CARS312	AT length ⁽⁶⁾		75		ps
CARS313	AT skew ⁽⁷⁾		14		ps
CARS314	AT skew ⁽⁸⁾			1	ps
CARS315	CK/ADDR_CTRL trace length			1020	ps
CARS316	Vias per trace			3 ⁽¹⁾	vias
CARS317	Via count difference			1 ⁽¹⁵⁾	vias
CARS318	Center-to-center CK to other DDR3 trace spacing ⁽⁹⁾	4w			
CARS319	Center-to-center ADDR_CTRL to other DDR3 trace spacing ⁽⁹⁾⁽¹⁰⁾	4w			
CARS320	Center-to-center ADDR_CTRL to other ADDR_CTRL trace spacing ⁽⁹⁾	3w			
CARS321	CK center-to-center spacing ⁽¹¹⁾⁽¹²⁾				
CARS322	CK spacing to other net ⁽⁹⁾	4w			

表 8-52. CK and ADDR_CTRL Routing Specification⁽²⁾⁽³⁾ (continued)

NO.	PARAMETER	MIN	TYP	MAX	UNIT
CARS323	Rcp ⁽¹³⁾	Zo-1	Zo	Zo+1	Ω
CARS324	Rtt ⁽¹³⁾⁽¹⁴⁾	Zo-5	Zo	Zo+5	Ω

- (1) Max value is based upon conservative signal integrity approach. This value could be extended only if detailed signal integrity analysis of rise time and fall time confirms desired operation.
- (2) The use of vias should be minimized.
- (3) Additional bypass capacitors are required when using the DDR_1V5 plane as the reference plane to allow the return current to jump between the DDR_1V5 plane and the ground plane when the net class switches layers at a via.
- (4) Non-mirrored configuration (all DDR3 memories on same side of PCB).
- (5) Mirrored configuration (one DDR3 device on top of the board and one DDR3 device on the bottom).
- (6) While this length can be increased for convenience, its length should be minimized.
- (7) ADDR_CTRL net class only (not CK net class). Minimizing this skew is recommended, but not required.
- (8) CK net class only.
- (9) Center-to-center spacing is allowed to fall to minimum 2w for up to 1250 mils of routed length.
- (10) The ADDR_CTRL net class of the other DDR EMIF is considered *other DDR3 trace spacing*.
- (11) CK spacing set to ensure proper differential impedance.
- (12) The most important thing to do is control the impedance so inadvertent impedance mismatches are not created. Generally speaking, center-to-center spacing should be either 2w or slightly larger than 2w to achieve a differential impedance equal to twice the single-ended impedance, Zo.
- (13) Source termination (series resistor at driver) is specifically not allowed.
- (14) Termination values should be uniform across the net class.
- (15) Via count difference may increase by 1 only if accurate 3-D modeling of the signal flight times – including accurately modeled signal propagation through vias – has been applied to ensure all segment skew maximums are not exceeded.

8.7.3.17.2 DQS and DQ Routing Specification

Skew within the DQS and DQ/DM net classes directly reduces setup and hold margin and thus this skew must be controlled. The only way to practically match lengths on a PCB is to lengthen the shorter traces up to the length of the longest net in the net class and its associated clock. As with CK and ADDR_CTRL, a reasonable trace route length is to within a percentage of its Manhattan distance. DQLM_n is defined as DQ Longest Manhattan distance n, where n is the byte number. For a 32-bit interface, there are four DQLMs, DQLM0-DQLM3. Likewise, for a 16-bit interface, there are two DQLMs, DQLM0-DQLM1.

注: It is not required, nor is it recommended, to match the lengths across all bytes. Length matching is only required within each byte.

Given the DQS and DQ/DM pin locations on the processor and the DDR3 memories, the maximum possible Manhattan distance can be determined given the placement. [图 8-84](#) shows this distance for four loads. It is from this distance that the specifications on the lengths of the transmission lines for the data bus are determined. For DQS and DQ/DM routing, these specifications are contained in [表 8-53](#).

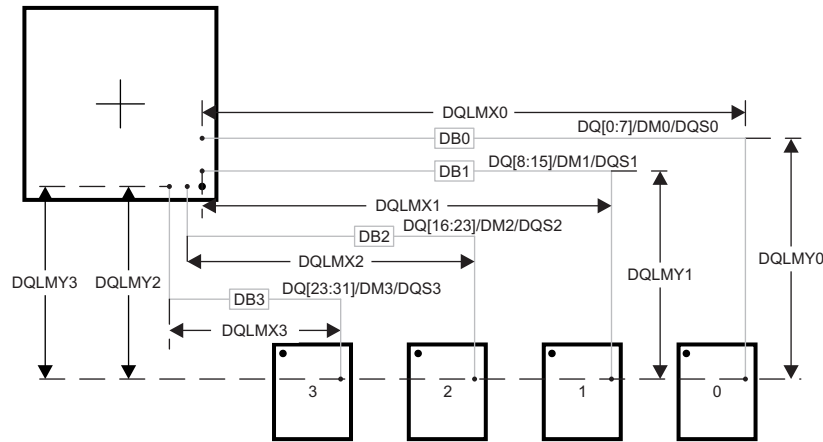

DB0 - DB3 represent data bytes 0 - 3.

There are four DQLMs, one for each byte (32-bit interface). Each DQLM is the longest Manhattan distance of the byte; therefore:

$$DQLM0 = DQLMX0 + DQLMY0$$

$$DQLM1 = DQLMX1 + DQLMY1$$

$$DQLM2 = DQLMX2 + DQLMY2$$

$$DQLM3 = DQLMX3 + DQLMY3$$

图 8-84. DQLM for Any Number of Allowed DDR3 Devices

表 8-53. Data Routing Specification⁽²⁾

NO.	PARAMETER	MIN	TYP	MAX	UNIT
DRS31	DB0 length			340	ps
DRS32	DB1 length			340	ps
DRS33	DB2 length			340	ps
DRS34	DB3 length			340	ps
DRS35	DBn skew ⁽³⁾			5	ps
DRS36	DQSn+ to DQSn- skew			1	ps
DRS37	DQSn to DBn skew ⁽³⁾⁽⁴⁾			5 ⁽¹⁰⁾	ps
DRS38	Vias per trace			2 ⁽¹⁾	vias
DRS39	Via count difference			0 ⁽¹⁰⁾	vias
DRS310	Center-to-center DBn to other DDR3 trace spacing ⁽⁶⁾	4			w ⁽⁵⁾
DRS311	Center-to-center DBn to other DBn trace spacing ⁽⁷⁾	3			w ⁽⁵⁾
DRS312	DQSn center-to-center spacing ^{(8) (9)}				
DRS313	DQSn center-to-center spacing to other net	4			w ⁽⁵⁾

(1) Max value is based upon conservative signal integrity approach. This value could be extended only if detailed signal integrity analysis of rise time and fall time confirms desired operation.

(2) External termination disallowed. Data termination should use built-in ODT functionality.

(3) Length matching is only done within a byte. Length matching across bytes is neither required nor recommended.

(4) Each DQS pair is length matched to its associated byte.

(5) Center-to-center spacing is allowed to fall to minimum 2w for up to 1250 mils of routed length.

(6) Other DDR3 trace spacing means other DDR3 net classes not within the byte.

(7) This applies to spacing within the net classes of a byte.

(8) DQS pair spacing is set to ensure proper differential impedance.

(9) The most important thing to do is control the impedance so inadvertent impedance mismatches are not created. Generally speaking, center-to-center spacing should be either 2w or slightly larger than 2w to achieve a differential impedance equal to twice the singleended impedance, Zo.

(10) Via count difference may increase by 1 only if accurate 3-D modeling of the signal flight times – including accurately modeled signal propagation through vias – has been applied to ensure DBn skew and DQSn to DBn skew maximums are not exceeded.

9 Device and Documentation Support

TI offers an extensive line of development tools, including methods to evaluate the performance of the processors, generate code, develop algorithm implementations, and fully integrate and debug software and hardware modules as listed below.

9.1 Device Nomenclature

To designate the stages in the product development cycle, TI assigns prefixes to the part numbers of all microprocessors (MPUs) and support tools. Each device has one of three prefixes: X, P, or null (no prefix) (for example, DRA7xx). Texas Instruments recommends two of three possible prefix designators for its support tools: TMDX and TMDS. These prefixes represent evolutionary stages of product development from engineering prototypes (TMDX) through fully qualified production devices and tools (TMDS).

Device development evolutionary flow:

X Experimental device that is not necessarily representative of the final device's electrical specifications and may not use production assembly flow.

P Prototype device that is not necessarily the final silicon die and may not necessarily meet final electrical specifications.

null Production version of the silicon die that is fully qualified.

Support tool development evolutionary flow:

TMDX Development-support product that has not yet completed Texas Instruments internal qualification testing.

TMDS Fully-qualified development-support product.

X and P devices and TMDX development-support tools are shipped against the following disclaimer:

"Developmental product is intended for internal evaluation purposes."

Production devices and TMDS development-support tools have been characterized fully, and the quality and reliability of the device have been demonstrated fully. TI's standard warranty applies.

Predictions show that prototype devices (X or P) have a greater failure rate than the standard production devices. Texas Instruments recommends that these devices not be used in any production system because their expected end-use failure rate still is undefined. Only qualified production devices are to be used.

For orderable part numbers of DRA7xx devices in the ABC package type, see the Package Option Addendum of this document, the TI website (ti.com), or contact your TI sales representative.

For additional description of the device nomenclature markings on the die, see the Silicon Errata (literature number SPRZ398).

9.1.1 Standard Package Symbolization

注: Some devices may have a cosmetic circular marking visible on the top of the device package which results from the production test process. In addition, some devices may also show a color variation in the package substrate which results from the substrate manufacturer. These differences are cosmetic only with no reliability impact.

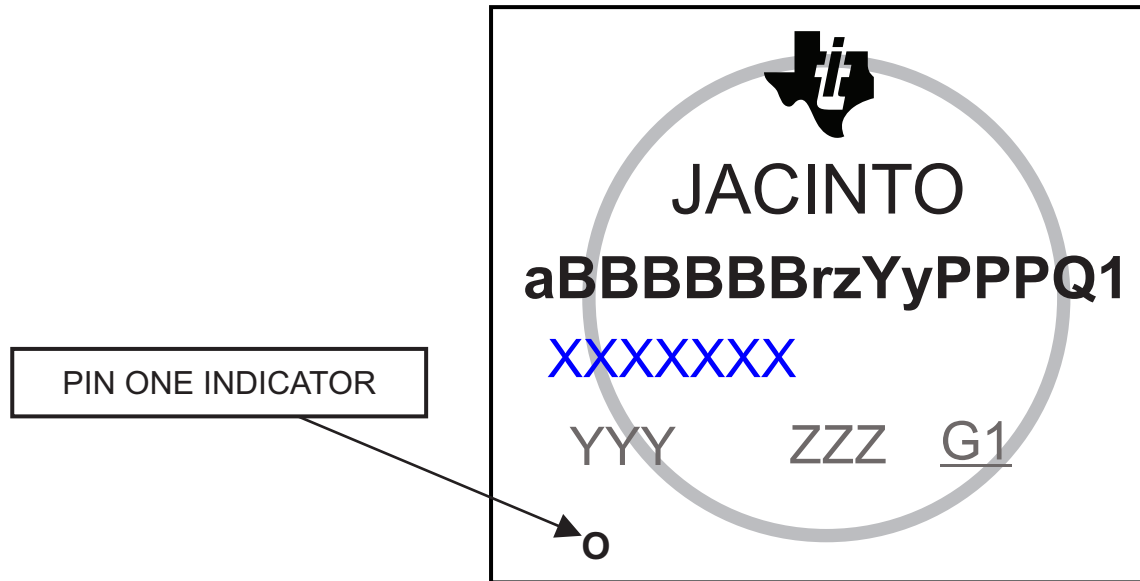

SWPS857_PACK_01

图 9-1. Printed Device Reference

9.1.2 Device Naming Convention

表 9-1. Nomenclature Description

FIELD PARAMETER	FIELD DESCRIPTION	VALUE	DESCRIPTION
a	Device evolution stage ⁽¹⁾	X	Prototype
		P	Preproduction (production test flow, no reliability data)
		BLANK	Production
BBBBBB ⁽²⁾	Base production part number	DRA744	J6 Low Tier
		DRA745	J6 Mid Tier
		DRA746	J6 High Tier
		DRA750	J6EP Low Tier
		DRA751	J6EP Mid Tier
		DRA752	J6EP High Tier
		DRA754	J6EX Low Tier
		DRA755	J6EX Mid Tier
		DRA756	J6EX High Tier
r	Device revision	BLANK	SR 1.0
		A	SR 1.1
		B	SR 2.0
z	Device Speed	P	High speed grade
		L	Overdrive speed grade
		J	Nominal speed grade
		OTHER	Alternate speed grade
Yy	Device type	G	General purpose (Prototype and Production)
		E	Emulation (E) devices
		D	High security prototype devices with TI Development keys (D)
		Yn	Letter followed by number indicates HS Device with customer key
PPP	Package designator	ABC	ABC S-PBGA-N760 (23mm x 23mm) Package

表 9-1. Nomenclature Description (continued)

FIELD PARAMETER	FIELD DESCRIPTION	VALUE	DESCRIPTION
Q1	Automotive Designator	BLANK	not meeting automotive qualification
		Q1	meeting Q100 equal requirements, with exceptions as specified in DM.
XXXXXXX	Lot Trace Code		
YYY	Production Code, For TI use only		
ZZZ	Production Code, For TI use only		
O	Pin one designator		
G1	ECAT—Green package designator		

- (1) To designate the stages in the product development cycle, TI assigns prefixes to the part numbers. These prefixes represent evolutionary stages of product development from engineering prototypes through fully qualified production devices.

Prototype devices are shipped against the following disclaimer:

“This product is still in development and is intended for internal evaluation purposes.”

Notwithstanding any provision to the contrary, TI makes no warranty expressed, implied, or statutory, including any implied warranty of merchantability of fitness for a specific purpose, of this device.

- (2) X5777x is the base part number for the superset device. Software should constrain the features used to match the intended production device.

注: BLANK in the symbol or part number is collapsed so there are no gaps between characters.

9.2 Tools and Software

The following products support development for DRA7xx platforms:

Design Kits and Evaluation Modules

DRA7xx Evaluation Module The Jacinto™ DRA7xx evaluation module platform designed to speed up development efforts and reduce time to market for applications such as infotainment, reconfigurable digital cluster or integrated digital cockpit. To allow scalability and re-use across DRA74x and DRA75x Jacinto Infotainment SoCs, the EVM is based on the Jacinto DRA75x SoC which incorporates a heterogeneous, scalable architecture that includes a mix of two Arm® Cortex®-A15 cores, two Arm® Cortex®-M4 processing subsystems, each with two Arm® Cortex®- cores, two C66x Digital Signal Processors (DSPs), a Vision AccelerationPac including two Embedded Vision Engines (EVEs), 2D- and 3D-graphics processing units including Imagination Technologies PowerVR® SGX544 dual-core and a high-definition image and video accelerator. It also integrates a host of peripherals including multi-camera interfaces (both parallel and serial) for LVDS-based surround view systems, displays, CAN and Gigabit Ethernet AVB. The main CPU board integrates these key peripherals such as Ethernet or HDMI, while the infotainment application daughter board (JAMR3) and LCD/TS daughter board will complement the CPU board to deliver complete system to jump start your evaluation and application development.

Development Tools

Clock Tree Tool for Sitara, Automotive, Vision Analytics, & Digital Signal Processors The Clock Tree Tool (CTT) for Sitara™ Arm®, Automotive, and Digital Signal Processors is an interactive clock tree configuration software that provides information about the clocks and modules in these TI devices. It allows the user to: Visualize the device clock tree. Interact with clock tree elements and view the effect on PRCM registers. Interact with the PRCM registers and view the effect on the device clock tree. View a trace of all the device registers affected by the user interaction with clock tree.

Pin mux tool The Pin MUX Utility is a software tool which provides a Graphical User Interface for configuring pin multiplexing settings, resolving conflicts and specifying I/O cell characteristics for TI MPUs. Results are output as C header/code files that can be imported into software development kits (SDKs) or used to configure customer's custom software. Version 4 of the Pin Mux utility adds the capability of automatically selecting a mux configuration that satisfies the entered requirements.

XDS110 JTAG Debug Probe The Texas Instruments XDS110 is a new class of debug probe (emulator) for TI embedded processors. The XDS110 replaces the XDS100 family while supporting a

wider variety of standards (IEEE1149.1, IEEE1149.7, SWD) in a single pod. Also, all XDS debug probes support Core and System Trace in all Arm and DSP processors that feature an Embedded Trace Buffer (ETB).

The Texas Instruments XDS110 connects to the target board via a TI 20-pin connector (with multiple adapters for TI 14-pin and, Arm 10-pin and Arm 20-pin) and to the host PC via USB2.0 High Speed (480Mbps). It also features two additional connections: the Auxiliary 14-pin port connector that enables EnergyTrace™, a full duplex UART port and four General-Purpose I/Os, and the Expansion 30-pin connector to connect the XDS110 EnergyTrace HDR add-on.

Models

[DRA75x and DRA74x BSDL Model](#) BSDL Model

[DRA75x and DRA74x IBIS Model](#) IBIS Model

[DRA75x and DRA74x Thermal Model](#) Thermal Model

For a complete listing of development-support tools for the processor platform, visit the Texas Instruments website at ti.com. For information on pricing and availability, contact the nearest TI field sales office or authorized distributor.

9.3 Documentation Support

To receive notification of documentation updates, navigate to the device product folder on ti.com. In the upper right corner, click on *Alert me* to register and receive a weekly digest of any product information that has changed. For change details, review the revision history included in any revised document.

The following documents describe the DRA75x/DRA74x devices.

Technical Reference Manual

[DRA75x, DRA74x SoC for Automotive Infotainment Silicon Revision 2.0, 1.x](#) Details the integration, the environment, the functional description, and the programming models for each peripheral and subsystem in the DRA75x/DRA74x family of devices.

Errata

[DRA75x, DRA74x SoC for Automotive Infotainment Silicon Revision 2.0, 1.1](#) Describes the known exceptions to the functional specifications for the device.

9.4 Related Links

The table below lists quick access links. Categories include technical documents, support and community resources, tools and software, and quick access to sample or buy.

表 9-2. Related Links

PARTS	PRODUCT FOLDER	SAMPLE & BUY	TECHNICAL DOCUMENTS	TOOLS & SOFTWARE	SUPPORT & COMMUNITY
DRA756	Click here	Click here	Click here	Click here	Click here
DRA755	Click here	Click here	Click here	Click here	Click here
DRA754	Click here	Click here	Click here	Click here	Click here
DRA752	Click here	Click here	Click here	Click here	Click here
DRA751	Click here	Click here	Click here	Click here	Click here
DRA750	Click here	Click here	Click here	Click here	Click here
DRA746	Click here	Click here	Click here	Click here	Click here
DRA745	Click here	Click here	Click here	Click here	Click here
DRA744	Click here	Click here	Click here	Click here	Click here

9.5 Community Resources

The following links connect to TI community resources. Linked contents are provided "AS IS" by the respective contributors. They do not constitute TI specifications and do not necessarily reflect TI's views; see TI's [Terms of Use](#).

TI E2E™ Online Community The TI engineer-to-engineer (E2E) community was created to foster collaboration among engineers. At e2e.ti.com, you can ask questions, share knowledge, explore ideas and help solve problems with fellow engineers.

TI Embedded Processors Wiki Established to help developers get started with Embedded Processors from Texas Instruments and to foster innovation and growth of general knowledge about the hardware and software surrounding these devices.

9.6 商標

Jacinto, E2E are trademarks of Texas Instruments.

Arm®/Neon is a trademark of Arm Limited (or its subsidiaries) in the US and/or elsewhere.

Arm, Cortex are registered trademarks of Arm Limited (or its subsidiaries) in the US and/or elsewhere.

HDQ is a trademark of Benchmarq.

1-Wire is a registered trademark of Dallas Semiconductor.

HDMI is a trademark of HDMI Licensing, LLC.

PowerVR is a registered trademark of Imagination Technologies Limited.

JTAG is a registered trademark of JTAG Technologies B.V.

MediaLB is a registered trademark of Microchip Technology Inc.

MMC, eMMC are trademarks of MultiMediaCard Association.

I²C is a trademark of NXP Semiconductors.

PCI-Express is a registered trademark of PCI-SIG.

SD is a registered trademark of SD Card Association.

Vivante is a registered trademark of Vivante Corporation.

All other trademarks are the property of their respective owners.

9.7 静電気放電に関する注意事項



すべての集積回路は、適切なESD保護方法を用いて、取扱いと保存を行うようにして下さい。

静電気放電はわずかな性能の低下から完全なデバイスの故障に至るまで、様々な損傷を与えます。高精度の集積回路は、損傷に対して敏感であり、極めてわずかなパラメータの変化により、デバイスに規定された仕様に適合しなくなる場合があります。

9.8 Glossary

TI Glossary This glossary lists and explains terms, acronyms, and definitions.

10 Mechanical, Packaging, and Orderable Information

10.1 Packaging Information

The following pages include mechanical, packaging, and orderable information. This information is the most current data available for the designated devices. This data is subject to change without notice and revision of this document. For browser-based versions of this data sheet, refer to the left-hand navigation.

PACKAGING INFORMATION

Orderable Device	Status (1)	Package Type	Package Drawing	Pins	Package Qty	Eco Plan (2)	Lead finish/ Ball material (6)	MSL Peak Temp (3)	Op Temp (°C)	Device Marking (4/5)	Samples
DRA744BJGABCRQ1	ACTIVE	FCBGA	ABC	760	250	RoHS & Green	Call TI	Level-3-250C-168 HR		DRA744BJGABCRQ1 842 842 ABC	Samples
DRA745BLGABCRQ1	ACTIVE	FCBGA	ABC	760	60	RoHS & Green	Call TI	Level-3-250C-168 HR	-40 to 125	DRA745BLGABCRQ1 842 842 ABC	Samples
DRA745BLGABCRQ1	ACTIVE	FCBGA	ABC	760	250	RoHS & Green	Call TI	Level-3-250C-168 HR	-40 to 125	DRA745BLGABCRQ1 842 842 ABC	Samples
DRA746APGABCRQ1	ACTIVE	FCBGA	ABC	760	60	RoHS & Green	Call TI	Level-3-250C-168 HR		DRA746APGABCRQ1 842 842 ABC	Samples
DRA750BJGABCRQ1	ACTIVE	FCBGA	ABC	760	250	RoHS & Green	Call TI	Level-3-250C-168 HR	-40 to 125	DRA750BJGABCRQ1 842 842 ABC	Samples
DRA756BPGABCRQ1	ACTIVE	FCBGA	ABC	760	60	RoHS & Green	Call TI	Level-3-250C-168 HR	-40 to 125	DRA756BPGABCRQ1 842 842 ABC	Samples

(1) The marketing status values are defined as follows:

ACTIVE: Product device recommended for new designs.

LIFEBUY: TI has announced that the device will be discontinued, and a lifetime-buy period is in effect.

NRND: Not recommended for new designs. Device is in production to support existing customers, but TI does not recommend using this part in a new design.

PREVIEW: Device has been announced but is not in production. Samples may or may not be available.

OBSELETE: TI has discontinued the production of the device.

(2) **RoHS:** TI defines "RoHS" to mean semiconductor products that are compliant with the current EU RoHS requirements for all 10 RoHS substances, including the requirement that RoHS substance do not exceed 0.1% by weight in homogeneous materials. Where designed to be soldered at high temperatures, "RoHS" products are suitable for use in specified lead-free processes. TI may reference these types of products as "Pb-Free".

RoHS Exempt: TI defines "RoHS Exempt" to mean products that contain lead but are compliant with EU RoHS pursuant to a specific EU RoHS exemption.

Green: TI defines "Green" to mean the content of Chlorine (Cl) and Bromine (Br) based flame retardants meet JS709B low halogen requirements of <=1000ppm threshold. Antimony trioxide based flame retardants must also meet the <=1000ppm threshold requirement.

(3) MSL, Peak Temp. - The Moisture Sensitivity Level rating according to the JEDEC industry standard classifications, and peak solder temperature.

(4) There may be additional marking, which relates to the logo, the lot trace code information, or the environmental category on the device.

⁽⁵⁾ Multiple Device Markings will be inside parentheses. Only one Device Marking contained in parentheses and separated by a "~" will appear on a device. If a line is indented then it is a continuation of the previous line and the two combined represent the entire Device Marking for that device.

⁽⁶⁾ Lead finish/Ball material - Orderable Devices may have multiple material finish options. Finish options are separated by a vertical ruled line. Lead finish/Ball material values may wrap to two lines if the finish value exceeds the maximum column width.

Important Information and Disclaimer:The information provided on this page represents TI's knowledge and belief as of the date that it is provided. TI bases its knowledge and belief on information provided by third parties, and makes no representation or warranty as to the accuracy of such information. Efforts are underway to better integrate information from third parties. TI has taken and continues to take reasonable steps to provide representative and accurate information but may not have conducted destructive testing or chemical analysis on incoming materials and chemicals. TI and TI suppliers consider certain information to be proprietary, and thus CAS numbers and other limited information may not be available for release.

In no event shall TI's liability arising out of such information exceed the total purchase price of the TI part(s) at issue in this document sold by TI to Customer on an annual basis.

EXAMPLE BOARD LAYOUT

ABC0760A

FCBGA - 2.96 mm max height

PLASTIC BALL GRID ARRAY

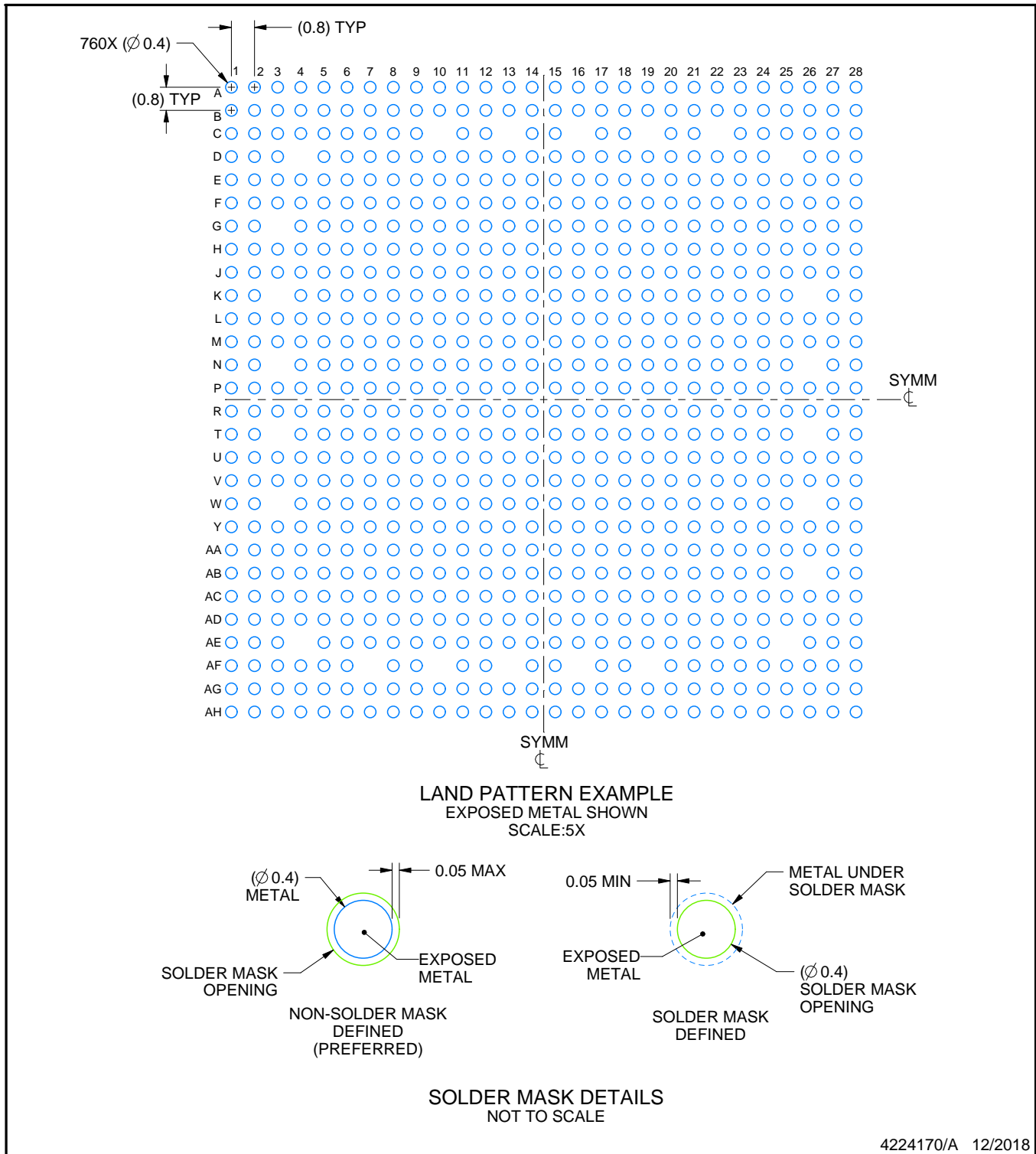

4224170/A 12/2018

NOTES: (continued)

- Final dimensions may vary due to manufacturing tolerance considerations and also routing constraints. For information, see Texas Instruments literature number SPRU811 (www.ti.com/lit/spru811).

EXAMPLE STENCIL DESIGN

ABC0760A

FCBGA - 2.96 mm max height

PLASTIC BALL GRID ARRAY

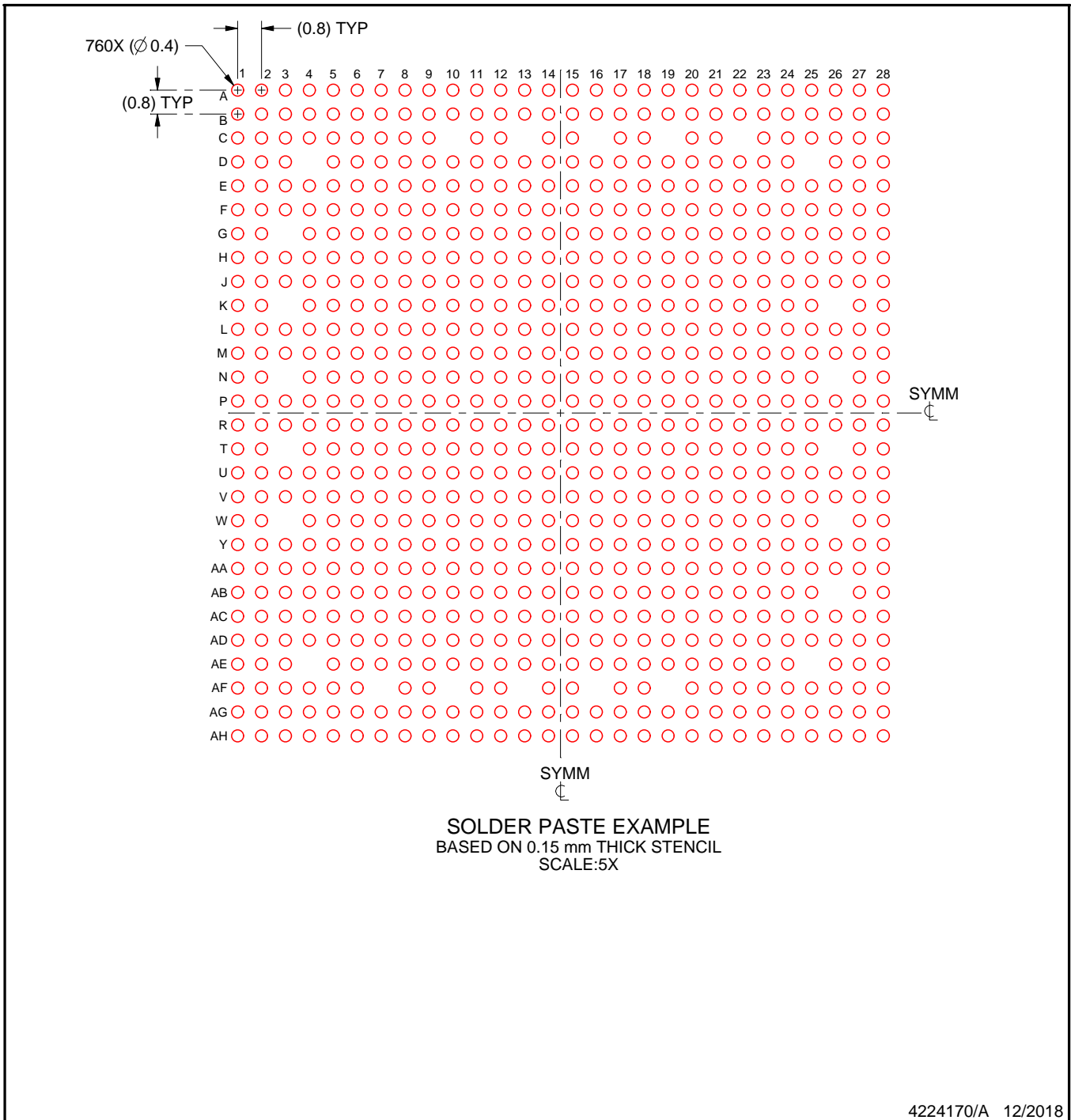

NOTES: (continued)

4. Laser cutting apertures with trapezoidal walls and rounded corners may offer better paste release.

重要なお知らせと免責事項

TI は、技術データと信頼性データ (データシートを含みます)、設計リソース (リファレンス・デザインを含みます)、アプリケーションや設計に関する各種アドバイス、Web ツール、安全性情報、その他のリソースを、欠陥が存在する可能性のある「現状のまま」提供しており、商品性および特定目的に対する適合性の黙示保証、第三者の知的財産権の非侵害保証を含むいかなる保証も、明示的または黙示的にかかわらず拒否します。

これらのリソースは、TI 製品を使用する設計の経験を積んだ開発者への提供を意図したものです。(1) お客様のアプリケーションに適した TI 製品の選定、(2) お客様のアプリケーションの設計、検証、試験、(3) お客様のアプリケーションに該当する各種規格や、その他のあらゆる安全性、セキュリティ、規制、または他の要件への確実な適合に関する責任を、お客様のみが単独で負うものとし、

上記の各種リソースは、予告なく変更される可能性があります。これらのリソースは、リソースで説明されている TI 製品を使用するアプリケーションの開発の目的でのみ、TI はその使用をお客様に許諾します。これらのリソースに関して、他の目的で複製することや掲載することは禁止されています。TI や第三者の知的財産権のライセンスが付与されている訳ではありません。お客様は、これらのリソースを自身で使用した結果発生するあらゆる申し立て、損害、費用、損失、責任について、TI およびその代理人を完全に補償するものとし、TI は一切の責任を拒否します。

TI の製品は、[TI の販売条件](#)、または [ti.com](#) やかかる TI 製品の関連資料などのいずれかを通じて提供する適用可能な条項の下で提供されています。TI がこれらのリソースを提供することは、適用される TI の保証または他の保証の放棄の拡大や変更を意味するものではありません。

お客様がいかなる追加条項または代替条項を提案した場合でも、TI はそれらに異議を唱え、拒否します。

郵送先住所 : Texas Instruments, Post Office Box 655303, Dallas, Texas 75265
Copyright © 2024, Texas Instruments Incorporated