

DRV5056-Q1 車載用ユニポーラ レシオメトリック リニア ホール効果センサ

1 特長

- 車載アプリケーション認定済み
- 以下の結果で AEC-Q100 認定済み:
 - デバイス温度グレード 0: 動作時周囲温度範囲 $-40^{\circ}\text{C} \sim 150^{\circ}\text{C}$
 - デバイス HBM ESD 分類レベル 2
 - デバイス CDM ESD 分類レベル C4B
- 機能安全対応
 - 機能安全システムの設計に役立つ資料を利用可能
- ユニポーラのリニア ホール効果磁気センサ
- 3.3V および 5V の電源で動作
- 0.6V の静止オフセット付きのアナログ出力
 - 電圧スイングの最大化により高精度
- 磁気感度オプション ($V_{CC} = 5V$ 時)
 - A1: 200mV/mT, 20mT 範囲
 - A2: 100mV/mT, 39mT 範囲
 - A3: 50mV/mT, 79mT 範囲
 - A4: 25mV/mT, 158mT 範囲
- 高速な 20kHz センシング帯域幅
- $\pm 1\text{mA}$ 駆動の低ノイズ出力
- 磁石温度ドリフト補償ありの
- 標準の産業用パッケージ:
 - 表面実装 SOT-23
 - スルーホール TO-92

2 アプリケーション

- 車載用位置センシング
- ブレーキ、アクセル、クラッチ ペダル
- トルク センサ、ギア シフト
- スロットル位置、高さレベリング
- パワートレインおよびトランスミッション コンポーネント
- 電流センシング

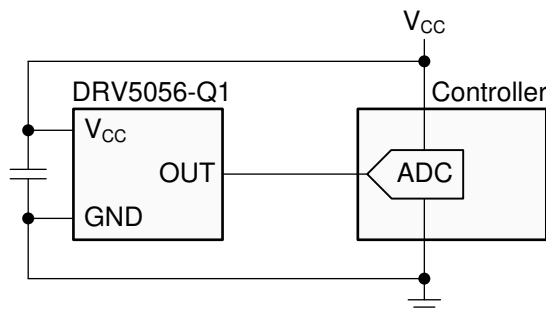

代表的な回路図

3 概要

DRV5056-Q1 はリニア ホール効果センサで、磁界の S 極の磁束密度に比例して応答します。このデバイスは、広範なアプリケーションにおいて、正確な位置センシングに使用できます。

ユニポーラの磁気応答が特徴で、アナログ入力は磁界が存在しないとき 0.6V に駆動され、磁界の S 極が印加されると増大します。この応答により、1 つの磁極を検出するアプリケーションで、出力のダイナミックレンジが最大化されます。4 つの感度オプションにより、必要なセンシング範囲に基づいて、さらに出力スイングを最大化できます。

このデバイスは、3.3V または 5V の電源で動作します。パッケージの上面に垂直な磁束が検出され、2 つのパッケージ オプションでセンシング方向が異なります。

デバイスは、レシオメトリック アーキテクチャを使用し、外部の A/DS コンバータ (ADC) が基準として同じ V_{CC} を使用しているとき、 V_{CC} の許容範囲から誤差を最小化できます。さらに、デバイスには磁石温度補償が搭載されており、磁石のドリフトを補償することで、 $-40^{\circ}\text{C} \sim +150^{\circ}\text{C}$ の広い温度範囲にわたって線形性の性能を実現します。

パッケージ情報

部品番号	パッケージ ⁽¹⁾	パッケージ サイズ ⁽²⁾
DRV5056-Q1	DBZ (SOT-23, 3)	2.92mm × 2.37mm
	LPG (TO-92, 3)	4.00mm × 1.52mm

- (1) 利用可能なパッケージについては、データシートの末尾にあるパッケージ オプションについての付録を参照してください。
- (2) パッケージ サイズ (長さ × 幅) は公称値で、該当する場合はピンも含まれます。

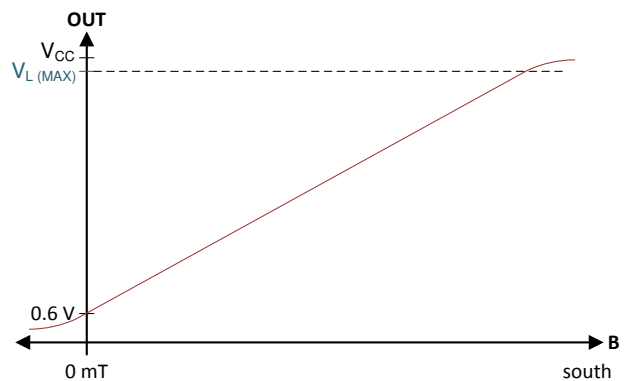

磁気応答



Table of Contents

1 特長	1	7 Application and Implementation	14
2 アプリケーション	1	7.1 Application Information.....	14
3 概要	1	7.2 Typical Application.....	15
4 Pin Configuration and Functions	3	7.3 Best System Practices.....	17
5 Specifications	4	7.4 Power Supply Recommendations.....	19
5.1 Absolute Maximum Ratings.....	4	7.5 Layout.....	19
5.2 ESD Ratings.....	4	8 Device and Documentation Support	20
5.3 Recommended Operating Conditions.....	4	8.1 Documentation Support.....	20
5.4 Thermal Information.....	4	8.2 ドキュメントの更新通知を受け取る方法.....	20
5.5 Electrical Characteristics.....	4	8.3 サポート・リソース.....	20
5.6 Magnetic Characteristics.....	5	8.4 Trademarks.....	20
5.7 Typical Characteristics.....	6	8.5 静電気放電に関する注意事項.....	20
6 Detailed Description	9	8.6 用語集.....	20
6.1 Overview.....	9	9 Revision History	20
6.2 Functional Block Diagram.....	9	10 Mechanical, Packaging, and Orderable Information	21
6.3 Feature Description.....	9		
6.4 Device Functional Modes.....	13		

4 Pin Configuration and Functions



図 4-1. DBZ Package 3-Pin SOT-23 Top View



図 4-2. LPG Package 3-Pin TO-92 Top View

表 4-1. Pin Functions

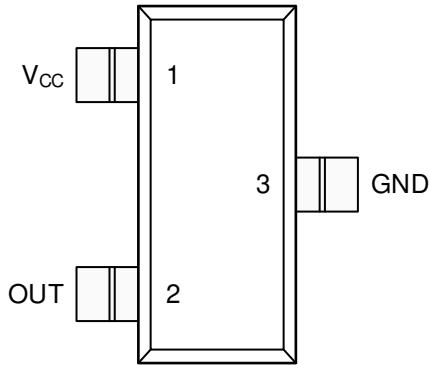
NAME	PIN		I/O	DESCRIPTION
	SOT-23	TO-92		
GND	3	2	—	Ground reference
OUT	2	3	O	Analog output
V _{CC}	1	1	—	Power supply. TI recommends connecting this pin to a ceramic capacitor to ground with a value of at least 0.1 μ F.

5 Specifications

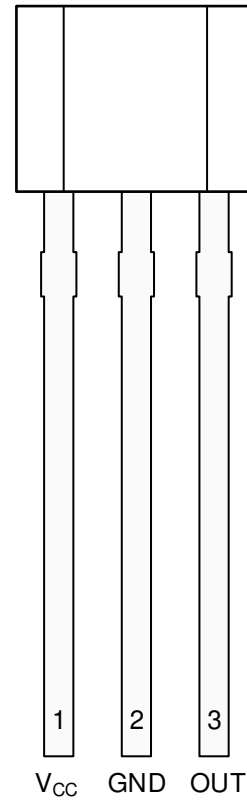
5.1 Absolute Maximum Ratings

over operating free-air temperature range (unless otherwise noted)⁽¹⁾

		MIN	MAX	UNIT
Power supply voltage	V _{CC}	-0.3	7	V
Output voltage	OUT	-0.3	V _{CC} + 0.3	V
Magnetic flux density, B _{MAX}		Unlimited		T
Operating junction temperature, T _J		-40	170	°C
Storage temperature, T _{stg}		-65	150	°C

- (1) Stresses beyond those listed under *Absolute Maximum Ratings* may cause permanent damage to the device. These are stress ratings only, which do not imply functional operation of the device at these or any other conditions beyond those indicated under *Recommended Operating Conditions*. Exposure to absolute-maximum-rated conditions for extended periods may affect device reliability.

5.2 ESD Ratings

			VALUE	UNIT
V _(ESD)	Electrostatic discharge	Human body model (HBM), per AEC Q100-002 ⁽¹⁾	±2500	V
		Charged device model (CDM), per AEC Q100-011	±750	

- (1) AEC Q100-002 indicates that HBM stressing shall be in accordance with the ANSI/ESDA/JEDEC JS-001 specification.

5.3 Recommended Operating Conditions

over operating free-air temperature range (unless otherwise noted)

		MIN	MAX	UNIT
V _{CC}	Power supply voltage ⁽¹⁾	3	3.6	V
		4.5	5.5	
I _O	Output continuous current	-1	1	mA
T _A	Operating ambient temperature ⁽²⁾	-40	150	°C

- (1) There are two isolated operating V_{CC} ranges. For more information see the [Operating V_{CC} Ranges](#) section.
 (2) Power dissipation and thermal limits must be observed.

5.4 Thermal Information

THERMAL METRIC ⁽¹⁾		DRV5056-Q1		UNIT
		SOT-23 (DBZ)	TO-92 (LPG)	
		3 PINS	3 PINS	
R _{θJA}	Junction-to-ambient thermal resistance	170	121	°C/W
R _{θJC(top)}	Junction-to-case (top) thermal resistance	66	67	°C/W
R _{θJB}	Junction-to-board thermal resistance	49	97	°C/W
Y _{JT}	Junction-to-top characterization parameter	1.7	7.6	°C/W
Y _{JB}	Junction-to-board characterization parameter	48	97	°C/W

- (1) For more information about traditional and new thermal metrics, see the [Semiconductor and IC Package Thermal Metrics](#) application report.

5.5 Electrical Characteristics

for V_{CC} = 3 V to 3.6 V and 4.5 V to 5.5 V, over operating free-air temperature range (unless otherwise noted)

PARAMETER		TEST CONDITIONS ⁽¹⁾	MIN	TYP	MAX	UNIT
I _{CC}	Operating supply current			6	10	mA
t _{ON}	Power-on time (see Figure 6-4)	B = 0 mT, no load on OUT		150	300	μs
f _{BW}	Sensing bandwidth			20		kHz
t _d	Propagation delay time	From change in B to change in OUT		10		μs

for $V_{CC} = 3\text{ V}$ to 3.6 V and 4.5 V to 5.5 V , over operating free-air temperature range (unless otherwise noted)

PARAMETER		TEST CONDITIONS ⁽¹⁾		MIN	TYP	MAX	UNIT
B _{ND}	Input-referred RMS noise density	V _{CC} = 5 V			130		nT/√Hz
		V _{CC} = 3.3 V			215		
B _N	Input-referred noise	B _{ND} × 6.6 × √20 kHz	V _{CC} = 5 V		0.12		mT _{PP}
			V _{CC} = 3.3 V		0.2		
V _N	Output-referred noise ⁽²⁾	B _N × S	DRV5056A1-Q1		24		mV _{PP}
			DRV5056A2-Q1		12		
			DRV5056A3-Q1		6		
			DRV5056A4-Q1		3		

(1) B is the applied magnetic flux density.

(2) V_N describes voltage noise on the device output. If the full device bandwidth is not needed, noise can be reduced with an RC filter.

5.6 Magnetic Characteristics

for $V_{CC} = 3\text{ V}$ to 3.6 V and 4.5 V to 5.5 V , over operating free-air temperature range (unless otherwise noted)

PARAMETER		TEST CONDITIONS ⁽¹⁾		MIN	TYP	MAX	UNIT
V _Q	Quiescent voltage	B = 0 mT, T _A = 25°C	DRV5056A1-Q1	0.535	0.6	0.665	V
			DRV5056A2-Q1	0.54	0.6	0.66	
			DRV5056A3-Q1, DRV5056A4-Q1	0.55	0.6	0.65	
V _{QΔT}	Quiescent voltage temperature drift	B = 0 mT, T _A = -40°C to 150°C versus 25°C	V _{CC} = 5 V		0.08		V
			V _{CC} = 3.3 V		0.04		
V _{QΔL}	Quiescent voltage lifetime drift	High-temperature operating stress for 1000 hours			< 0.5%		
S	Sensitivity	V _{CC} = 5 V, T _A = 25°C	DRV5056A1-Q1	190	200	210	mV/mT
			DRV5056A2-Q1	95	100	105	
			DRV5056A3-Q1	47.5	50	52.5	
			DRV5056A4-Q1	23.8	25	26.2	
		V _{CC} = 3.3 V, T _A = 25°C	DRV5056A1-Q1	114	120	126	
			DRV5056A2-Q1	57	60	63	
			DRV5056A3-Q1	28.5	30	31.5	
			DRV5056A4-Q1	14.3	15	15.8	
B _L	Linear magnetic sensing range ⁽²⁾	V _{CC} = 5 V, T _A = 25°C	DRV5056A1-Q1	20			mT
			DRV5056A2-Q1	39			
			DRV5056A3-Q1	79			
			DRV5056A4-Q1	158			
		V _{CC} = 3.3 V, T _A = 25°C	DRV5056A1-Q1	19			
			DRV5056A2-Q1	39			
			DRV5056A3-Q1	78			
			DRV5056A4-Q1	155			
V _L	Linear range of output voltage ⁽³⁾		V _Q		V _{CC} - 0.2		V
S _{TC}	Sensitivity temperature compensation for magnets ⁽⁴⁾				0.12		%/°C
S _{LE}	Sensitivity linearity error ⁽³⁾	V _{OUT} is within V _L			±1%		
S _{RE}	Sensitivity ratiometry error ⁽⁵⁾	T _A = 25°C, with respect to V _{CC} = 3.3 V or 5 V		-2.5%		2.5%	
S _{ΔL}	Sensitivity lifetime drift	High-temperature operating stress for 1000 hours			< 0.5%		

(1) B is the applied magnetic flux density.

DRV5056-Q1

JAJSED8B – JANUARY 2018 – REVISED DECEMBER 2024

- (2) B_L describes the minimum linear sensing range at 25°C taking into account the maximum V_Q and Sensitivity tolerances.
- (3) See the [Sensitivity Linearity](#) section.
- (4) S_{TC} describes the rate the device increases Sensitivity with temperature. For more information, see the [Sensitivity Temperature Compensation For Magnets](#) section.
- (5) See the [Ratiometric Architecture](#) section.

5.7 Typical Characteristics

at $T_A = 25^\circ\text{C}$ (unless otherwise noted)

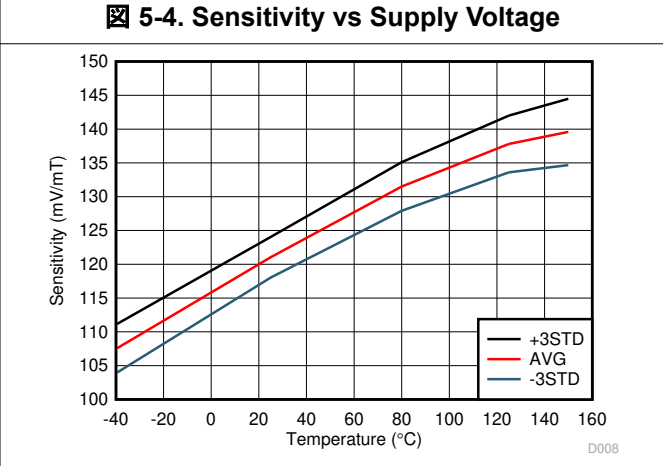
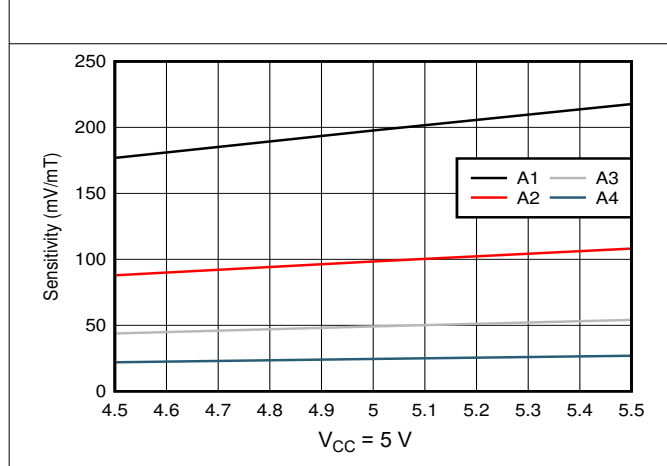
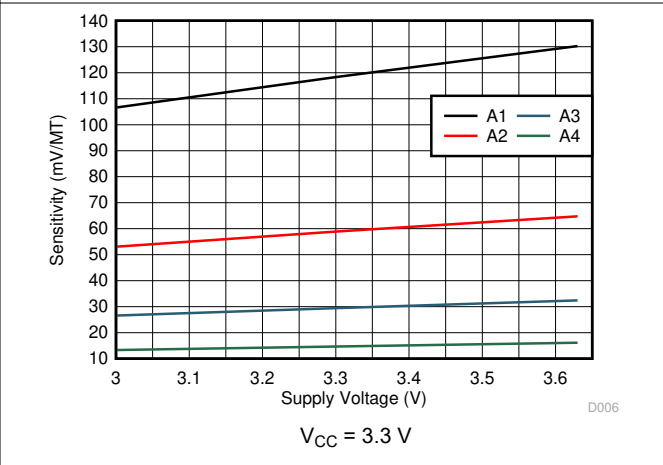
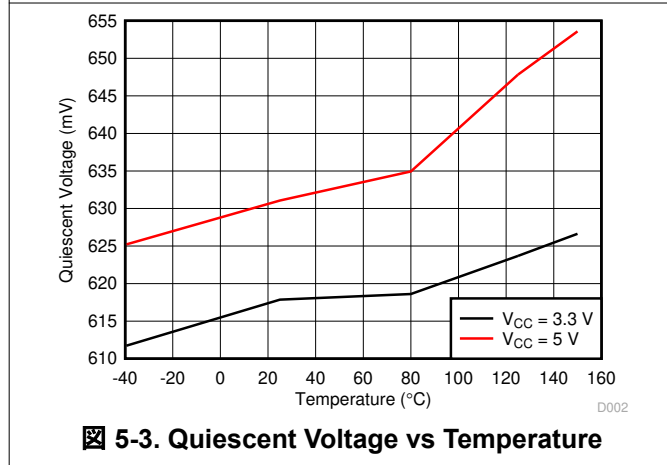
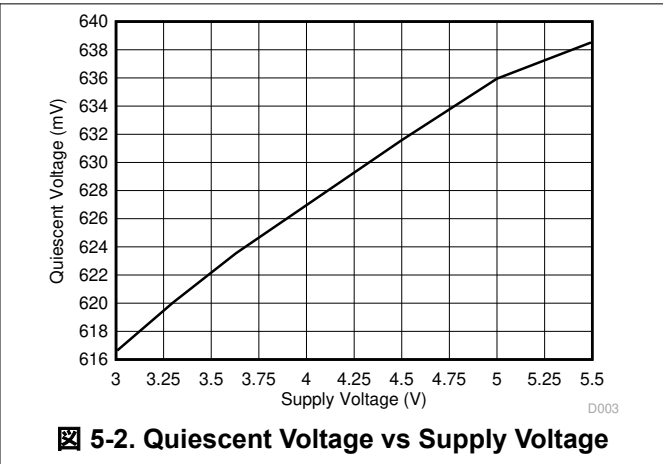
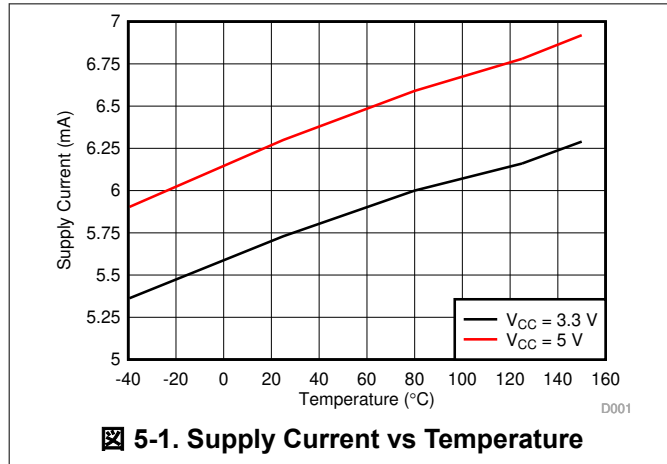

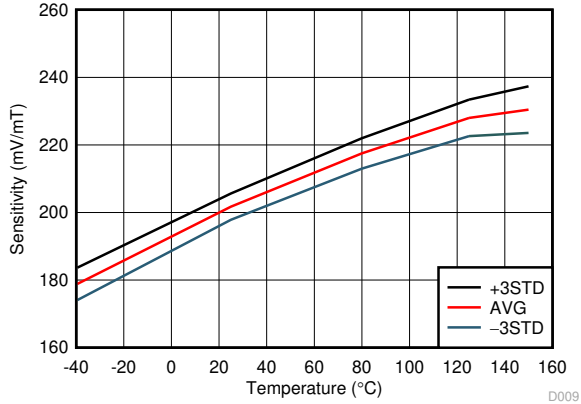

5-7. Sensitivity vs Temperature

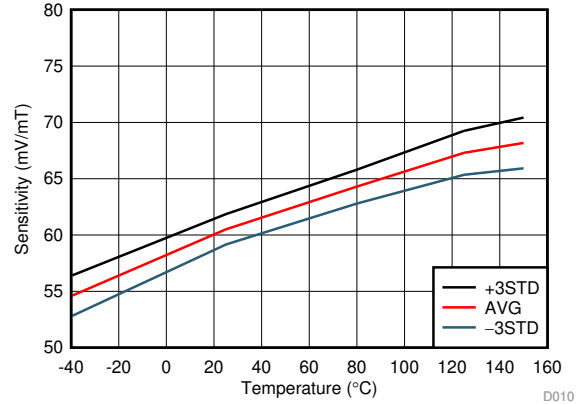

5-8. Sensitivity vs Temperature

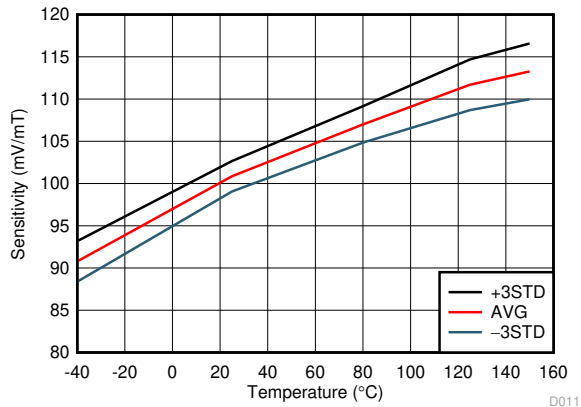

5-9. Sensitivity vs Temperature

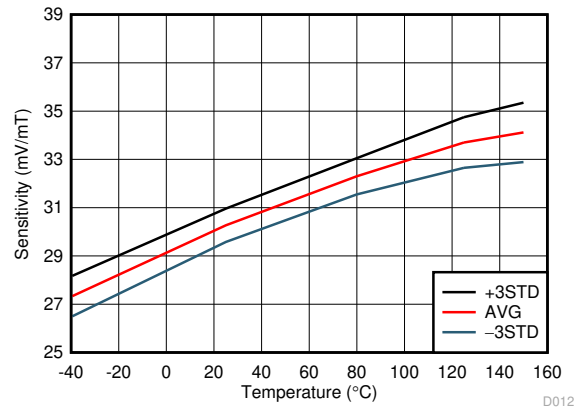

5-10. Sensitivity vs Temperature

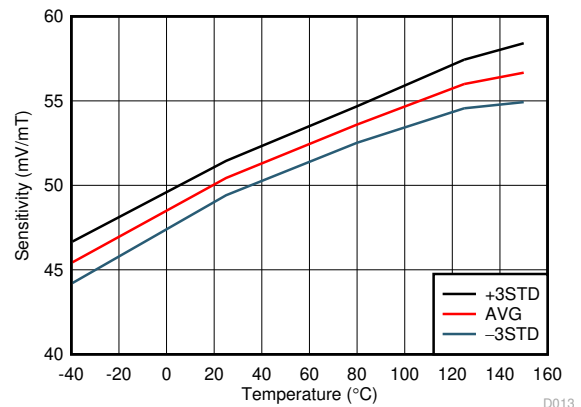

5-11. Sensitivity vs Temperature

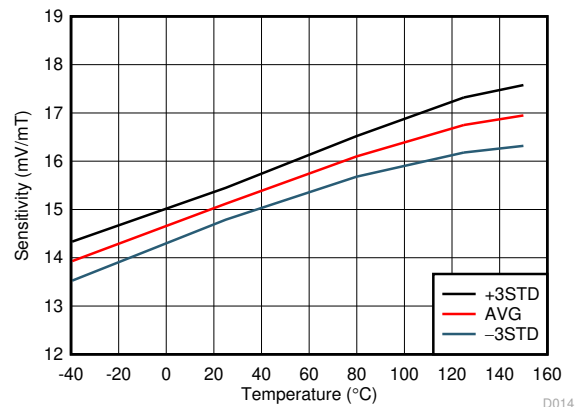

5-12. Sensitivity vs Temperature

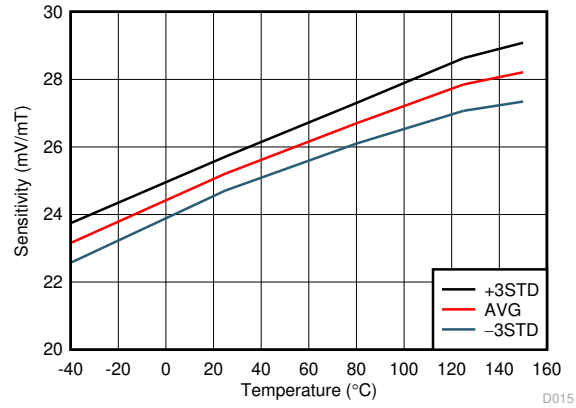

DRV5056A4-Q1, V_{CC} = 5.0 V

D015

図 5-13. Sensitivity vs Temperature

6 Detailed Description

6.1 Overview

The DRV5056-Q1 is a 3-pin linear Hall-effect sensor with fully integrated signal conditioning, temperature compensation circuits, mechanical stress cancellation, and amplifiers. The device operates from 3.3-V and 5-V ($\pm 10\%$) power supplies, measures magnetic flux density, and outputs a proportional analog voltage that is referenced to V_{CC} .

6.2 Functional Block Diagram

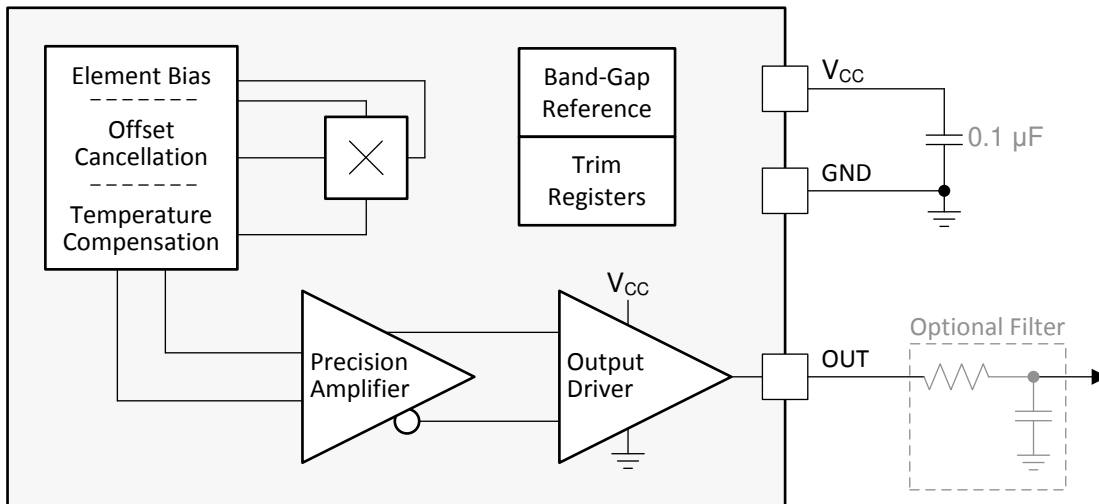

6.3 Feature Description

6.3.1 Magnetic Flux Direction

As shown in [Figure 6-1](#), the DRV5056-Q1 is sensitive to the magnetic field component that is perpendicular to the die inside the package.

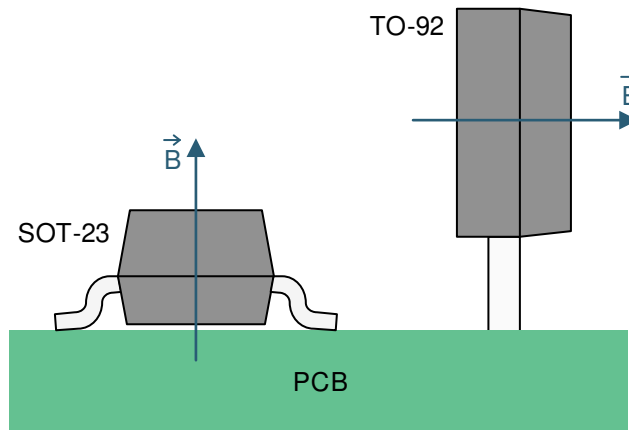

Figure 6-1. Direction of Sensitivity

Magnetic flux that travels from the bottom to the top of the package is considered positive. This condition exists when a south magnetic pole is near the top (marked-side) of the package. Magnetic flux that travels from the top to the bottom of the package results in negative millitesla values.



图 6-2. The Flux Direction for Positive B

6.3.2 Magnetic Response

The DRV5056-Q1 outputs an analog voltage according to 式 1 when in the presence of a magnetic field:

$$V_{OUT} = V_Q + B \times (\text{Sensitivity}_{(25^\circ\text{C})} \times (1 + S_{TC} \times (T_A - 25^\circ\text{C}))) \quad (1)$$

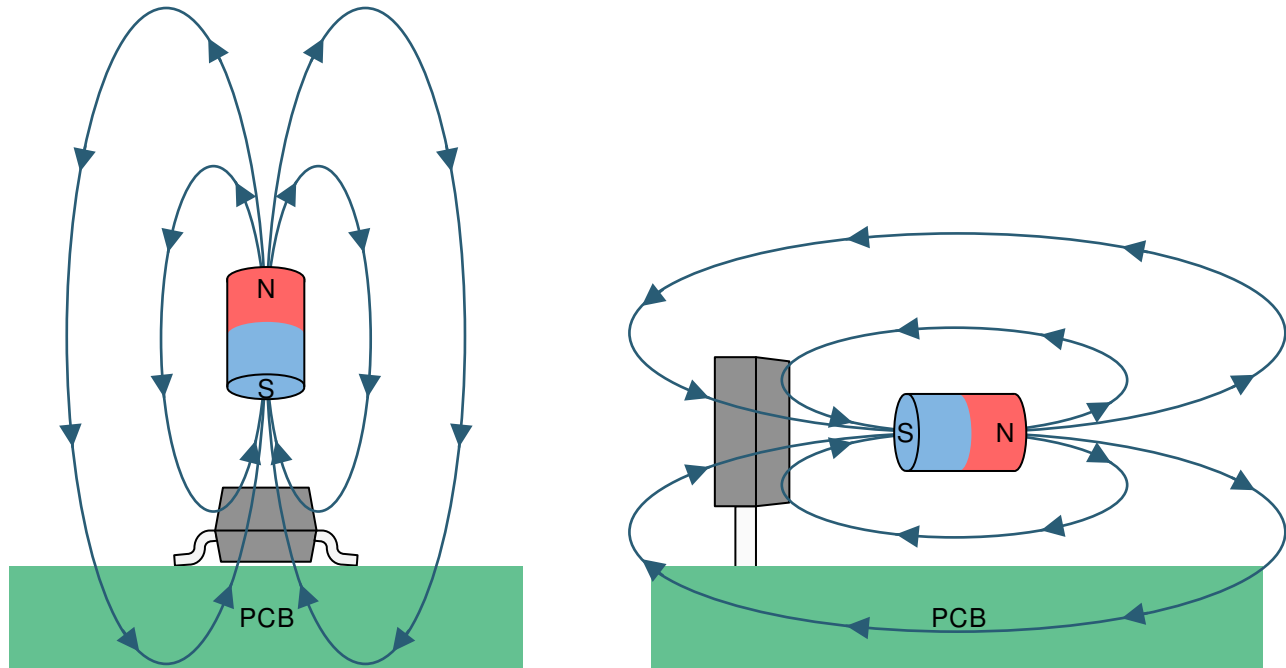
where

- V_Q is typically 600 mV
- B is the applied magnetic flux density
- $\text{Sensitivity}_{(25^\circ\text{C})}$ depends on the device option and V_{CC}
- S_{TC} is typically 0.12%/°C
- T_A is the ambient temperature
- V_{OUT} is within the V_L range

As an example, consider the DRV5056A3-Q1 with $V_{CC} = 3.3$ V, a temperature of 50°C, and 67 mT applied. Excluding tolerances, $V_{OUT} = 600$ mV + 67 mT × (30 mV/mT × [1 + 0.0012/°C × (50°C – 25°C)]) = 2.67 V.

The DRV5056-Q1 only responds to the flux density of a magnetic south pole.

6.3.3 Sensitivity Linearity

The device produces a linear response when the output voltage is within the specified V_L range. Outside this range, sensitivity is reduced and nonlinear. 図 6-3 graphs the magnetic response.



図 6-3. Magnetic Response

式 2 calculates parameter B_L , the minimum linear sensing range at 25°C taking into account the maximum quiescent voltage and sensitivity tolerances.

$$B_{L(MIN)} = \frac{V_{L(MAX)} - V_{Q(MAX)}}{S_{(MAX)}} \quad (2)$$

The parameter S_{LE} defines linearity error as the difference in sensitivity between any two positive B values when the output is within the V_L range.

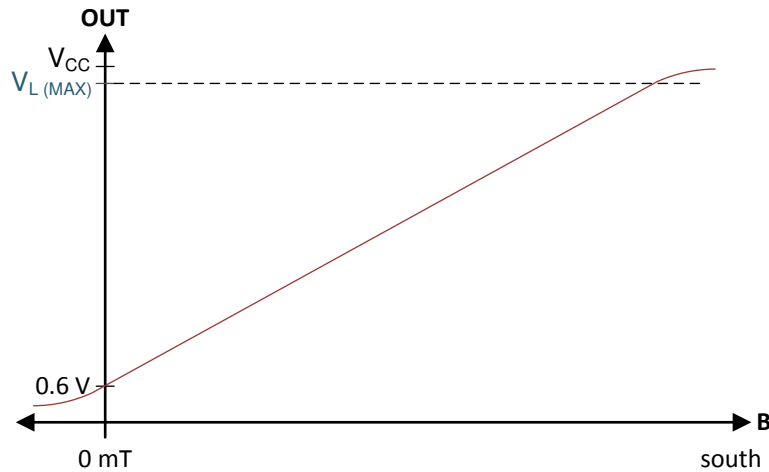
6.3.4 Ratiometric Architecture

The DRV5056-Q1 has a ratiometric analog architecture that scales the sensitivity linearly with the power-supply voltage. For example, the sensitivity is 5% higher when $V_{CC} = 5.25$ V compared to $V_{CC} = 5$ V. This behavior enables external ADCs to digitize a more consistent value regardless of the power-supply voltage tolerance, when the ADC uses V_{CC} as its reference.

式 3 calculates sensitivity ratiometry error:

$$S_{RE} = 1 - \frac{S_{(V_{CC})} / S_{(5V)}}{V_{CC} / 5V} \text{ for } V_{CC} = 4.5 \text{ V to } 5.5 \text{ V}, \quad S_{RE} = 1 - \frac{S_{(V_{CC})} / S_{(3.3V)}}{V_{CC} / 3.3V} \text{ for } V_{CC} = 3 \text{ V to } 3.6 \text{ V} \quad (3)$$

where

- $S_{(V_{CC})}$ is the sensitivity at the current V_{CC} voltage
- $S_{(5V)}$ or $S_{(3.3V)}$ is the sensitivity when $V_{CC} = 5$ V or 3.3 V
- V_{CC} is the current V_{CC} voltage

6.3.5 Operating V_{CC} Ranges

The DRV5056-Q1 has two recommended operating V_{CC} ranges: 3 V to 3.6 V and 4.5 V to 5.5 V. When V_{CC} is in the middle region between 3.6 V to 4.5 V, the device continues to function, but sensitivity is less known because there is a crossover threshold near 4 V that adjusts device characteristics.

6.3.6 Sensitivity Temperature Compensation For Magnets

Magnets generally produce weaker fields as temperature increases. The DRV5056-Q1 compensates by increasing sensitivity with temperature, as defined by the parameter S_{TC} . The sensitivity at $T_A = 125^\circ\text{C}$ is typically 12% higher than at $T_A = 25^\circ\text{C}$.

6.3.7 Power-On Time

After the V_{CC} voltage is applied, the DRV5056-Q1 requires a short initialization time before the output is set. The parameter t_{ON} describes the time from when V_{CC} crosses 3 V until OUT is within 5% of V_Q , with 0 mT applied and no load attached to OUT. [Figure 6-4](#) shows this timing diagram.

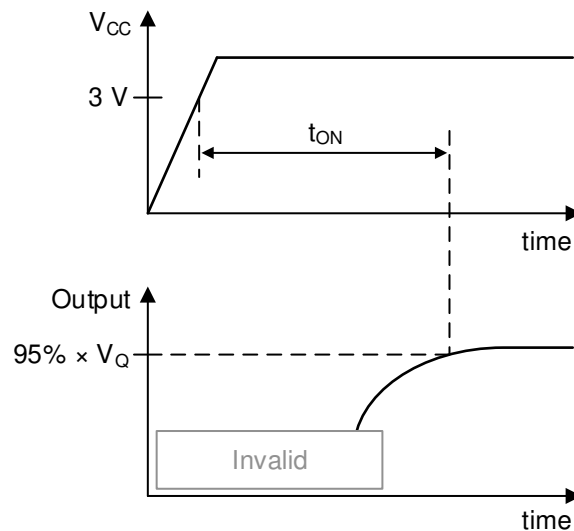

Figure 6-4. t_{ON} Definition

6.3.8 Hall Element Location

Figure 6-5 shows the location of the sensing element inside each package option.

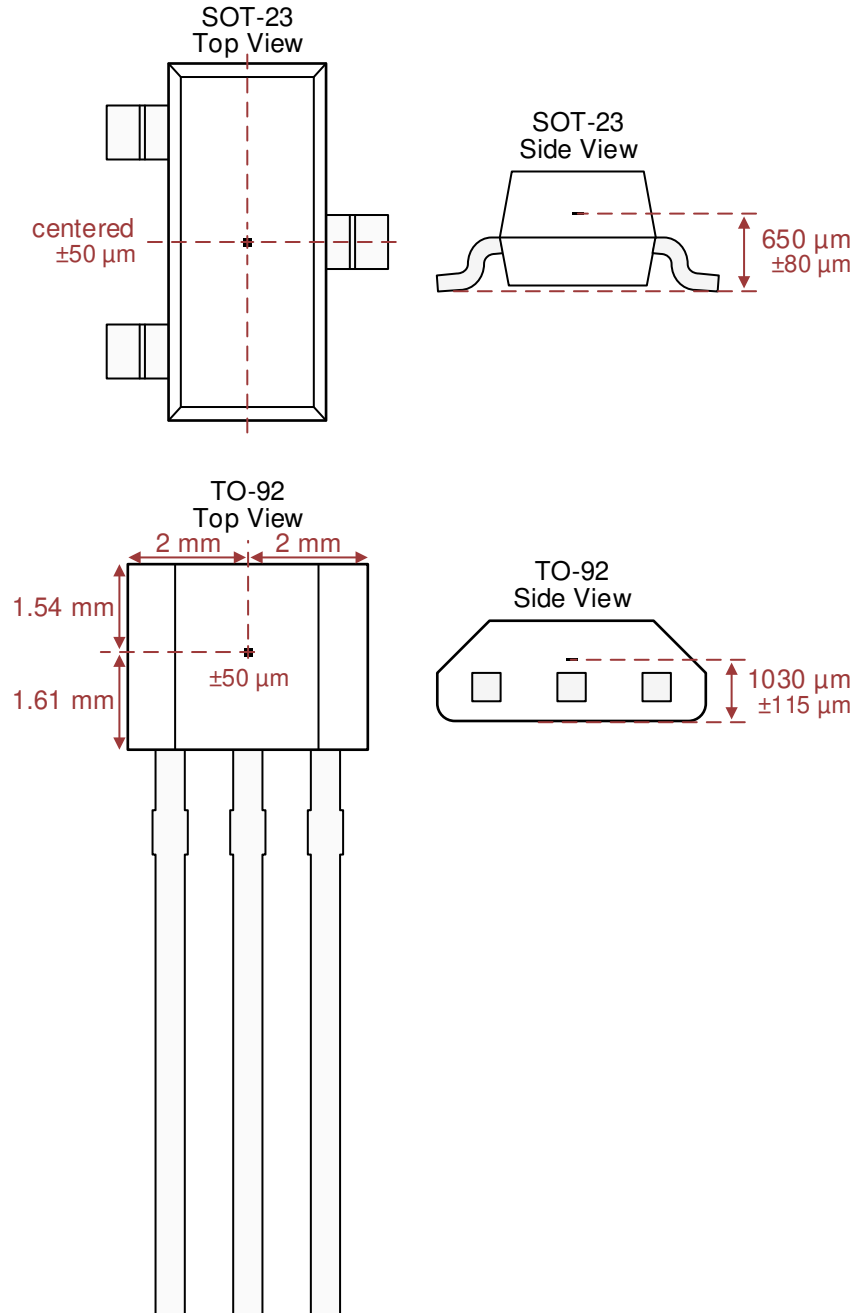

Figure 6-5. Hall Element Location

6.4 Device Functional Modes

The DRV5056-Q1 has one mode of operation that applies when the *Recommended Operating Conditions* are met.

7 Application and Implementation

注

以下のアプリケーション情報は、TI の製品仕様に含まれるものではなく、TI ではその正確性または完全性を保証いたしません。個々の目的に対する製品の適合性については、お客様の責任で判断していただくこととなります。お客様は自身の設計実装を検証しテストすることで、システムの機能を確認する必要があります。

7.1 Application Information

7.1.1 Selecting the Sensitivity Option

Select the highest DRV5056-Q1 sensitivity option that can measure the required range of magnetic flux density, so that the output voltage swing is maximized.

Larger magnets and greater sensing distances can generally enable better positional accuracy than very small magnets at close distances, because magnetic flux density increases exponentially with the proximity to a magnet.

7.1.2 Temperature Compensation for Magnets

The DRV5056-Q1 temperature compensation is designed to directly compensate the average drift of neodymium (NdFeB) magnets and partially compensate ferrite magnets. The residual flux density (B_r) of a magnet typically reduces by 0.12%/°C for NdFeB, and 0.20%/°C for ferrite. When the operating temperature range of a system is reduced, temperature drift errors are also reduced.

7.1.3 Adding a Low-Pass Filter

As illustrated in the [Functional Block Diagram](#), an RC low-pass filter can be added to the device output for the purpose of minimizing voltage noise when the full 20-kHz bandwidth is not needed. This filter can improve the signal-to-noise ratio (SNR) and overall accuracy. Do not connect a capacitor directly to the device output without a resistor in between because doing so can make the output unstable.

7.1.4 Designing for Wire Break Detection

Some systems must detect if interconnect wires become open or shorted. The DRV5056-Q1 can support this function.

First, select a sensitivity option that causes the output voltage to stay within the V_L range during normal operation. Second, add a pullup resistor between OUT and V_{CC} . TI recommends a value between 20 k Ω to 100 k Ω , and the current through OUT must not exceed the I_O specification, including current going into an external ADC. Then, if the output voltage is ever measured to be within 150 mV of V_{CC} or GND, a fault condition exists. [図 7-1](#) shows the circuit, and [表 7-1](#) describes fault scenarios.



図 7-1. Wire Fault Detection Circuit

表 7-1. Fault Scenarios and the Resulting V_{OUT}

FAULT SCENARIO	V_{OUT}
V_{CC} disconnects	Close to GND
GND disconnects	Close to V_{CC}
V_{CC} shorts to OUT	Close to V_{CC}
GND shorts to OUT	Close to GND

7.2 Typical Application

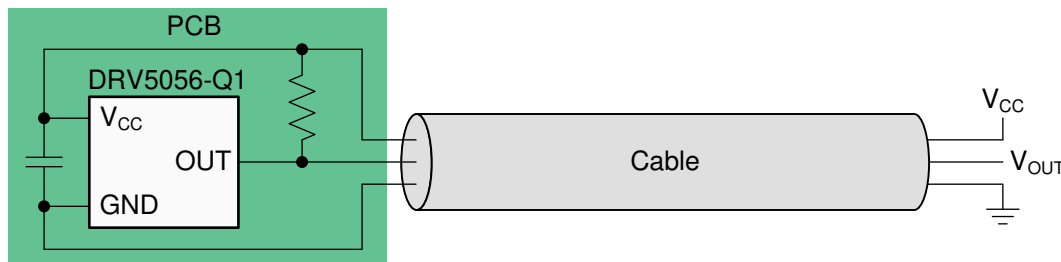

図 7-2. Unipolar Sensing Application

7.2.1 Design Requirements

Use the parameters listed in 表 7-2 for this design example.

表 7-2. Design Parameters

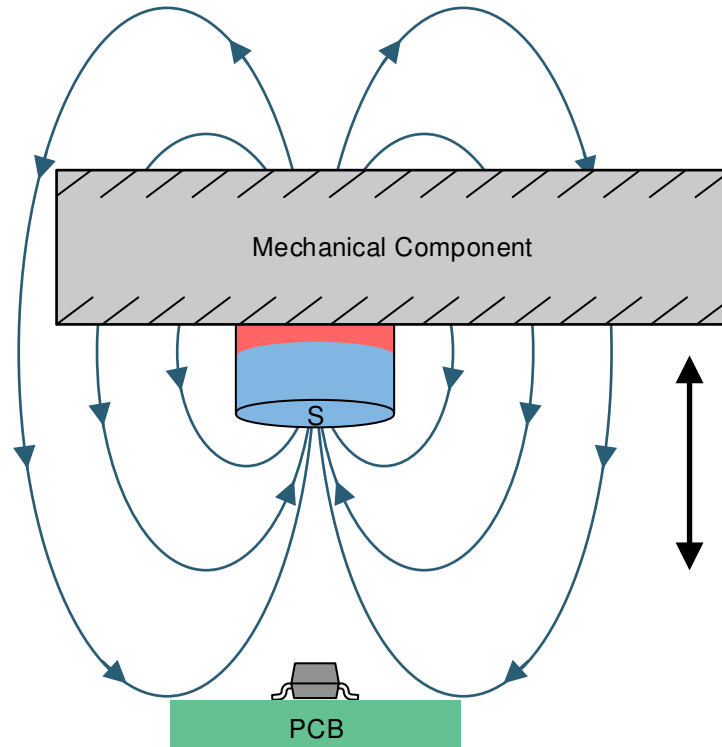
DESIGN PARAMETER	EXAMPLE VALUE
V_{CC}	3.3 V
Magnet	10-mm diameter × 6-mm long cylinder, ferrite
Distance from magnet to sensor	From 20 mm to 3 mm
Maximum B at the sensor at 25°C	72 mT at 3 mm
Device option	DRV5056A3-Q1

7.2.2 Detailed Design Procedure

This design example consists of a mechanical component that moves back and forth, an embedded magnet with the south pole facing the printed-circuit board, and a DRV5056-Q1. The DRV5056-Q1 outputs an analog voltage that describes the precise position of the component. The component must not contain ferromagnetic materials such as iron, nickel, and cobalt because these materials change the magnetic flux density at the sensor.

When designing a linear magnetic sensing system, always consider these three variables: the magnet, sensing distance, and range of the sensor. Select the DRV5056-Q1 with the highest sensitivity that has a B_L (linear magnetic sensing range) that is larger than the maximum magnetic flux density in the application.

Magnets are made from various ferromagnetic materials that have tradeoffs in cost, drift with temperature, absolute maximum temperature ratings, remanence or residual induction (B_r), and coercivity (H_c). The B_r and the dimensions of a magnet determine the magnetic flux density (B) produced in 3-dimensional space. For simple magnet shapes, such as rectangular blocks and cylinders, there are simple equations that solve B at a given distance centered with the magnet. 図 7-3 shows diagrams for 式 4 and 式 5.



図 7-3. Rectangular Block and Cylinder Magnets

Use 式 4 for the rectangular block shown in 図 7-3:

$$\vec{B} = \frac{B_r}{\pi} \left(\arctan\left(\frac{WL}{2D\sqrt{4D^2 + W^2 + L^2}}\right) - \arctan\left(\frac{WL}{2(D+T)\sqrt{4(D+T)^2 + W^2 + L^2}}\right) \right) \quad (4)$$

Use 式 5 for the cylinder shown in 図 7-3:

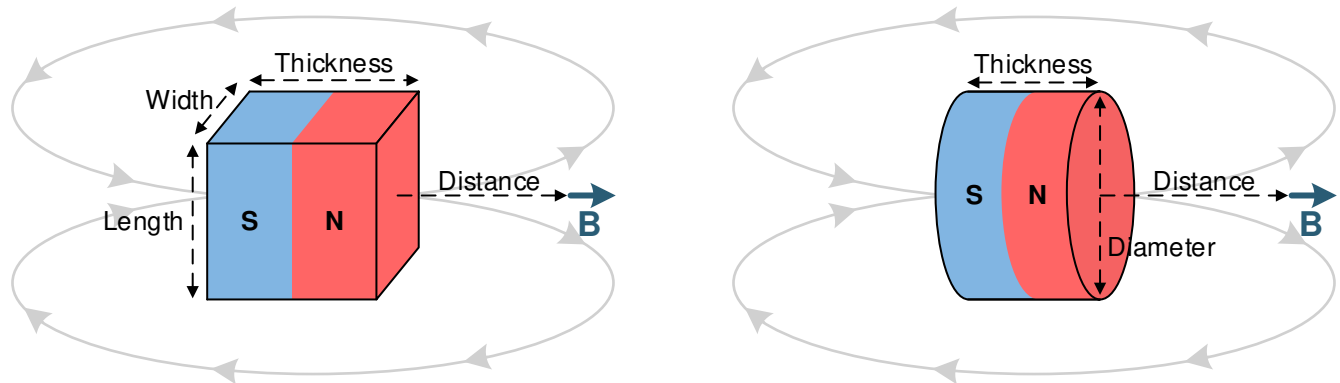
$$\vec{B} = \frac{B_r}{2} \left(\frac{D+T}{\sqrt{(0.5C)^2 + (D+T)^2}} - \frac{D}{\sqrt{(0.5C)^2 + D^2}} \right) \quad (5)$$

where

- W is width
- L is length
- T is thickness (the direction of magnetization)
- D is distance
- C is diameter

7.2.3 Application Curve

Figure 7-4 shows the magnetic flux density versus distance for a 10-mm × 6-mm cylinder ferrite magnet.

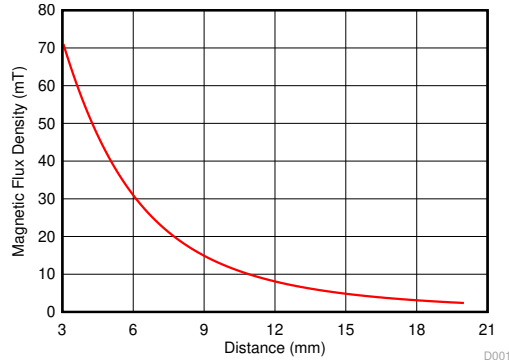

Figure 7-4. Magnetic Profile of a 10-mm × 6-mm Cylindrical Ferrite Magnet

7.3 Best System Practices

Because the Hall element is sensitive to magnetic fields that are perpendicular to the top of the package, a correct magnet approach must be used for the sensor to detect the field. Figure 7-5 illustrates correct and incorrect approaches.



図 7-5. Correct and Incorrect Magnet Approaches

7.4 Power Supply Recommendations

A decoupling capacitor close to the device must be used to provide local energy with minimal inductance. TI recommends using a ceramic capacitor with a value of at least 0.01 μF .

7.5 Layout

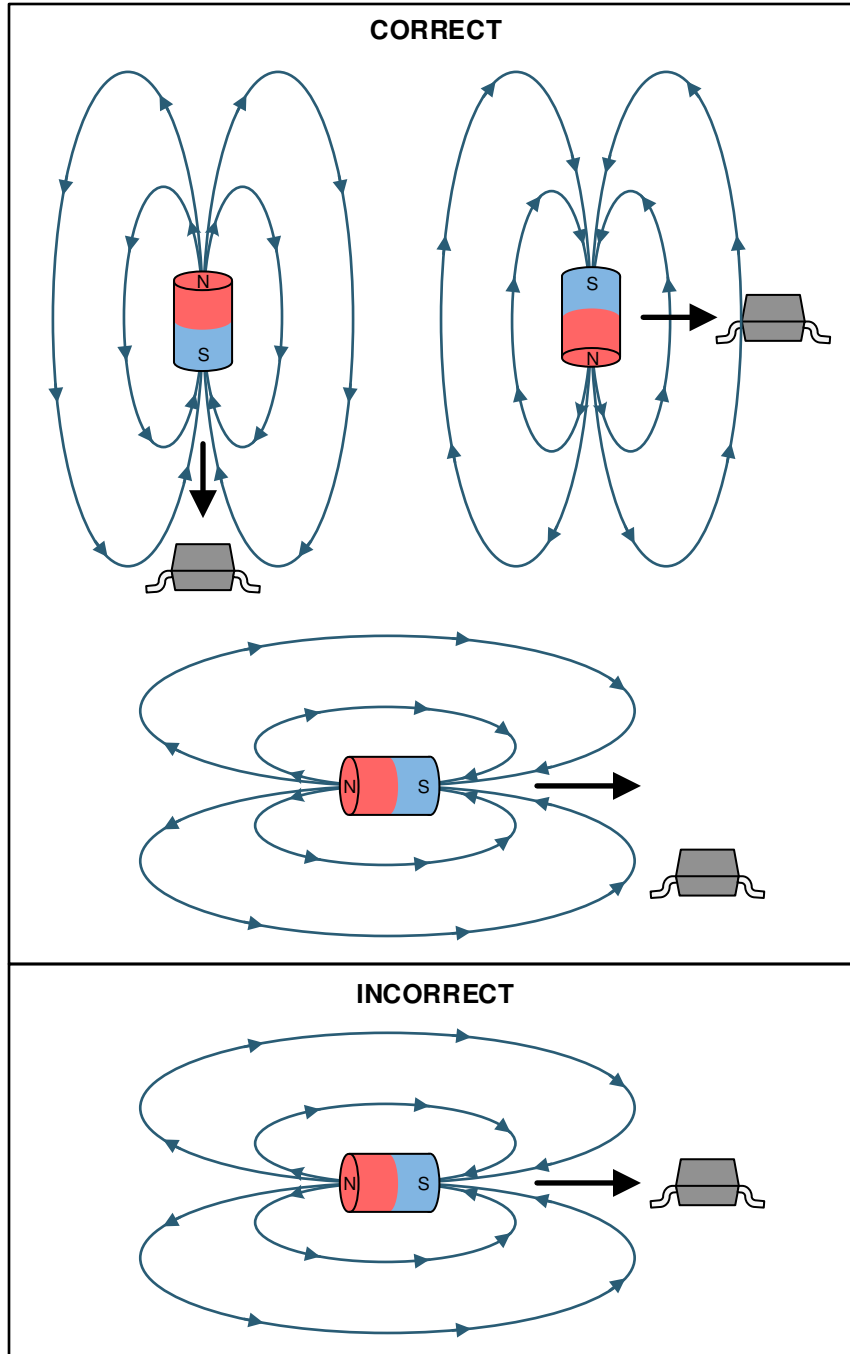
7.5.1 Layout Guidelines

Magnetic fields pass through most nonferromagnetic materials with no significant disturbance. Embedding Hall-effect sensors within plastic or aluminum enclosures and sensing magnets on the outside is common practice. Magnetic fields also easily pass through most printed-circuit boards, which makes placing the magnet on the opposite side possible.

7.5.2 Layout Examples

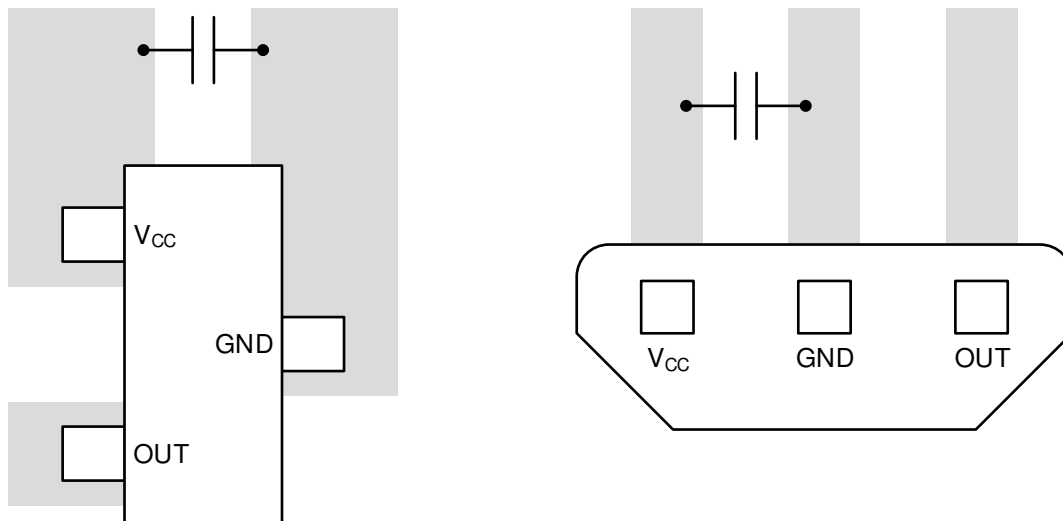

☒ 7-6. Layout Examples

8 Device and Documentation Support

8.1 Documentation Support

8.1.1 Related Documentation

For related documentation see the following:

- Texas Instruments, [Incremental rotary encoder design considerations application note](#)
- Texas Instruments, [Using linear hall effect sensors to measure angle application note](#)
- Texas Instruments, [Angle measurements with linear hall effect sensors](#)

8.2 ドキュメントの更新通知を受け取る方法

ドキュメントの更新についての通知を受け取るには、www.tij.co.jp のデバイス製品フォルダを開いてください。[通知] をクリックして登録すると、変更されたすべての製品情報に関するダイジェストを毎週受け取ることができます。変更の詳細については、改訂されたドキュメントに含まれている改訂履歴をご覧ください。

8.3 サポート・リソース

テキサス・インスツルメンツ E2E™ サポート・フォーラムは、エンジニアが検証済みの回答と設計に関するヒントをエキスパートから迅速かつ直接得ることができる場所です。既存の回答を検索したり、独自の質問をしたりすることで、設計に必要な支援を迅速に得ることができます。

リンクされているコンテンツは、各寄稿者により「現状のまま」提供されるものです。これらはテキサス・インスツルメンツの仕様を構成するものではなく、必ずしもテキサス・インスツルメンツの見解を反映したものではありません。テキサス・インスツルメンツの[使用条件](#)を参照してください。

8.4 Trademarks

テキサス・インスツルメンツ E2E™ is a trademark of Texas Instruments.

すべての商標は、それぞれの所有者に帰属します。

8.5 静電気放電に関する注意事項



この IC は、ESD によって破損する可能性があります。テキサス・インスツルメンツは、IC を取り扱う際には常に適切な注意を払うことを推奨します。正しい取り扱いおよび設置手順に従わない場合、デバイスを破損するおそれがあります。

ESD による破損は、わずかな性能低下からデバイスの完全な故障まで多岐にわたります。精密な IC の場合、パラメータがわずかに変化するだけで公表されている仕様から外れる可能性があるため、破損が発生しやすくなっています。

8.6 用語集

[テキサス・インスツルメンツ用語集](#) この用語集には、用語や略語の一覧および定義が記載されています。

9 Revision History

資料番号末尾の英字は改訂を表しています。その改訂履歴は英語版に準じています。

Changes from Revision A (August 2018) to Revision B (December 2024)	Page
• ドキュメント全体にわたって表、図、相互参照の採番方法を更新.....	1
• 「特長」セクションに機能安全の情報を追加	1
• 「製品情報」の表を「パッケージ情報」に変更	1
• Added Y-axis title to 図 5-5	6
• Changed <i>What to Do and What Not to Do</i> section to <i>Best System Practices</i>	17

Changes from Revision * (January 2018) to Revision A (August 2018)	Page
• 量産用にリリース.....	1

10 Mechanical, Packaging, and Orderable Information

The following pages include mechanical, packaging, and orderable information. This information is the most current data available for the designated devices. This data is subject to change without notice and revision of this document. For browser-based versions of this data sheet, refer to the left-hand navigation.

PACKAGING INFORMATION

Orderable part number	Status (1)	Material type (2)	Package Pins	Package qty Carrier	RoHS (3)	Lead finish/ Ball material (4)	MSL rating/ Peak reflow (5)	Op temp (°C)	Part marking (6)
DRV5056A1EDBZRQ1	Active	Production	SOT-23 (DBZ) 3	3000 LARGE T&R	Yes	SN	Level-3-260C-168 HR	-40 to 150	56A1Z
DRV5056A1EDBZRQ1.A	Active	Production	SOT-23 (DBZ) 3	3000 LARGE T&R	Yes	SN	Level-3-260C-168 HR	-40 to 150	56A1Z
DRV5056A1EDBZRQ1.B	Active	Production	SOT-23 (DBZ) 3	3000 LARGE T&R	Yes	SN	Level-3-260C-168 HR	-40 to 150	56A1Z
DRV5056A1ELPGMQ1	Active	Production	TO-92 (LPG) 3	3000 AMMO	Yes	SN	N/A for Pkg Type	-40 to 150	56A1Z
DRV5056A1ELPGMQ1.A	Active	Production	TO-92 (LPG) 3	3000 AMMO	Yes	SN	N/A for Pkg Type	-40 to 150	56A1Z
DRV5056A1ELPGMQ1.B	Active	Production	TO-92 (LPG) 3	3000 AMMO	Yes	SN	N/A for Pkg Type	-40 to 150	56A1Z
DRV5056A1ELPGQ1	Active	Production	TO-92 (LPG) 3	1000 BULK	Yes	SN	N/A for Pkg Type	-40 to 150	56A1Z
DRV5056A1ELPGQ1.A	Active	Production	TO-92 (LPG) 3	1000 BULK	Yes	SN	N/A for Pkg Type	-40 to 150	56A1Z
DRV5056A1ELPGQ1.B	Active	Production	TO-92 (LPG) 3	1000 BULK	Yes	SN	N/A for Pkg Type	-40 to 150	56A1Z
DRV5056A2EDBZRQ1	Active	Production	SOT-23 (DBZ) 3	3000 LARGE T&R	Yes	SN	Level-3-260C-168 HR	-40 to 150	56A2Z
DRV5056A2EDBZRQ1.A	Active	Production	SOT-23 (DBZ) 3	3000 LARGE T&R	Yes	SN	Level-3-260C-168 HR	-40 to 150	56A2Z
DRV5056A2EDBZRQ1.B	Active	Production	SOT-23 (DBZ) 3	3000 LARGE T&R	Yes	SN	Level-3-260C-168 HR	-40 to 150	56A2Z
DRV5056A2ELPGMQ1	Active	Production	TO-92 (LPG) 3	3000 AMMO	Yes	SN	N/A for Pkg Type	-40 to 150	56A2Z
DRV5056A2ELPGMQ1.A	Active	Production	TO-92 (LPG) 3	3000 AMMO	Yes	SN	N/A for Pkg Type	-40 to 150	56A2Z
DRV5056A2ELPGMQ1.B	Active	Production	TO-92 (LPG) 3	3000 AMMO	Yes	SN	N/A for Pkg Type	-40 to 150	56A2Z
DRV5056A2ELPGQ1	Active	Production	TO-92 (LPG) 3	1000 BULK	Yes	SN	N/A for Pkg Type	-40 to 150	56A2Z
DRV5056A2ELPGQ1.A	Active	Production	TO-92 (LPG) 3	1000 BULK	Yes	SN	N/A for Pkg Type	-40 to 150	56A2Z
DRV5056A2ELPGQ1.B	Active	Production	TO-92 (LPG) 3	1000 BULK	Yes	SN	N/A for Pkg Type	-40 to 150	56A2Z
DRV5056A3EDBZRQ1	Active	Production	SOT-23 (DBZ) 3	3000 LARGE T&R	Yes	SN	Level-3-260C-168 HR	-40 to 150	56A3Z
DRV5056A3EDBZRQ1.A	Active	Production	SOT-23 (DBZ) 3	3000 LARGE T&R	Yes	SN	Level-3-260C-168 HR	-40 to 150	56A3Z
DRV5056A3EDBZRQ1.B	Active	Production	SOT-23 (DBZ) 3	3000 LARGE T&R	Yes	SN	Level-3-260C-168 HR	-40 to 150	56A3Z
DRV5056A3ELPGMQ1	Active	Production	TO-92 (LPG) 3	3000 AMMO	Yes	SN	N/A for Pkg Type	-40 to 150	56A3Z
DRV5056A3ELPGMQ1.A	Active	Production	TO-92 (LPG) 3	3000 AMMO	Yes	SN	N/A for Pkg Type	-40 to 150	56A3Z
DRV5056A3ELPGMQ1.B	Active	Production	TO-92 (LPG) 3	3000 AMMO	Yes	SN	N/A for Pkg Type	-40 to 150	56A3Z
DRV5056A3ELPGQ1	Active	Production	TO-92 (LPG) 3	1000 BULK	Yes	SN	N/A for Pkg Type	-40 to 150	56A3Z
DRV5056A3ELPGQ1.A	Active	Production	TO-92 (LPG) 3	1000 BULK	Yes	SN	N/A for Pkg Type	-40 to 150	56A3Z
DRV5056A3ELPGQ1.B	Active	Production	TO-92 (LPG) 3	1000 BULK	Yes	SN	N/A for Pkg Type	-40 to 150	56A3Z
DRV5056A4EDBZRQ1	Active	Production	SOT-23 (DBZ) 3	3000 LARGE T&R	Yes	SN	Level-3-260C-168 HR	-40 to 150	56A4Z
DRV5056A4EDBZRQ1.A	Active	Production	SOT-23 (DBZ) 3	3000 LARGE T&R	Yes	SN	Level-3-260C-168 HR	-40 to 150	56A4Z

Orderable part number	Status (1)	Material type (2)	Package Pins	Package qty Carrier	RoHS (3)	Lead finish/ Ball material (4)	MSL rating/ Peak reflow (5)	Op temp (°C)	Part marking (6)
DRV5056A4EDBZRQ1.B	Active	Production	SOT-23 (DBZ) 3	3000 LARGE T&R	Yes	SN	Level-3-260C-168 HR	-40 to 150	56A4Z
DRV5056A4ELPGMQ1	Active	Production	TO-92 (LPG) 3	3000 AMMO	Yes	SN	N/A for Pkg Type	-40 to 150	56A4Z
DRV5056A4ELPGMQ1.A	Active	Production	TO-92 (LPG) 3	3000 AMMO	Yes	SN	N/A for Pkg Type	-40 to 150	56A4Z
DRV5056A4ELPGMQ1.B	Active	Production	TO-92 (LPG) 3	3000 AMMO	Yes	SN	N/A for Pkg Type	-40 to 150	56A4Z
DRV5056A4ELPGQ1	Active	Production	TO-92 (LPG) 3	1000 BULK	Yes	SN	N/A for Pkg Type	-40 to 150	56A4Z
DRV5056A4ELPGQ1.A	Active	Production	TO-92 (LPG) 3	1000 BULK	Yes	SN	N/A for Pkg Type	-40 to 150	56A4Z
DRV5056A4ELPGQ1.B	Active	Production	TO-92 (LPG) 3	1000 BULK	Yes	SN	N/A for Pkg Type	-40 to 150	56A4Z

(1) **Status:** For more details on status, see our [product life cycle](#).

(2) **Material type:** When designated, preproduction parts are prototypes/experimental devices, and are not yet approved or released for full production. Testing and final process, including without limitation quality assurance, reliability performance testing, and/or process qualification, may not yet be complete, and this item is subject to further changes or possible discontinuation. If available for ordering, purchases will be subject to an additional waiver at checkout, and are intended for early internal evaluation purposes only. These items are sold without warranties of any kind.

(3) **RoHS values:** Yes, No, RoHS Exempt. See the [TI RoHS Statement](#) for additional information and value definition.

(4) **Lead finish/Ball material:** Parts may have multiple material finish options. Finish options are separated by a vertical ruled line. Lead finish/Ball material values may wrap to two lines if the finish value exceeds the maximum column width.

(5) **MSL rating/Peak reflow:** The moisture sensitivity level ratings and peak solder (reflow) temperatures. In the event that a part has multiple moisture sensitivity ratings, only the lowest level per JEDEC standards is shown. Refer to the shipping label for the actual reflow temperature that will be used to mount the part to the printed circuit board.

(6) **Part marking:** There may be an additional marking, which relates to the logo, the lot trace code information, or the environmental category of the part.

Multiple part markings will be inside parentheses. Only one part marking contained in parentheses and separated by a "-" will appear on a part. If a line is indented then it is a continuation of the previous line and the two combined represent the entire part marking for that device.

Important Information and Disclaimer: The information provided on this page represents TI's knowledge and belief as of the date that it is provided. TI bases its knowledge and belief on information provided by third parties, and makes no representation or warranty as to the accuracy of such information. Efforts are underway to better integrate information from third parties. TI has taken and continues to take reasonable steps to provide representative and accurate information but may not have conducted destructive testing or chemical analysis on incoming materials and chemicals. TI and TI suppliers consider certain information to be proprietary, and thus CAS numbers and other limited information may not be available for release.

In no event shall TI's liability arising out of such information exceed the total purchase price of the TI part(s) at issue in this document sold by TI to Customer on an annual basis.

OTHER QUALIFIED VERSIONS OF DRV5056-Q1 :

- Catalog : [DRV5056](#)

NOTE: Qualified Version Definitions:

- Catalog - TI's standard catalog product

TAPE AND REEL INFORMATION

QUADRANT ASSIGNMENTS FOR PIN 1 ORIENTATION IN TAPE

*All dimensions are nominal

Device	Package Type	Package Drawing	Pins	SPQ	Reel Diameter (mm)	Reel Width W1 (mm)	A0 (mm)	B0 (mm)	K0 (mm)	P1 (mm)	W (mm)	Pin1 Quadrant
DRV5056A1EDBZRQ1	SOT-23	DBZ	3	3000	180.0	8.4	3.15	2.77	1.22	4.0	8.0	Q3
DRV5056A2EDBZRQ1	SOT-23	DBZ	3	3000	180.0	8.4	3.15	2.77	1.22	4.0	8.0	Q3
DRV5056A4EDBZRQ1	SOT-23	DBZ	3	3000	180.0	8.4	3.15	2.77	1.22	4.0	8.0	Q3

TAPE AND REEL BOX DIMENSIONS

*All dimensions are nominal

Device	Package Type	Package Drawing	Pins	SPQ	Length (mm)	Width (mm)	Height (mm)
DRV5056A1EDBZRQ1	SOT-23	DBZ	3	3000	213.0	191.0	35.0
DRV5056A2EDBZRQ1	SOT-23	DBZ	3	3000	213.0	191.0	35.0
DRV5056A4EDBZRQ1	SOT-23	DBZ	3	3000	213.0	191.0	35.0

EXAMPLE BOARD LAYOUT

DBZ0003A

SOT-23 - 1.12 mm max height

SMALL OUTLINE TRANSISTOR

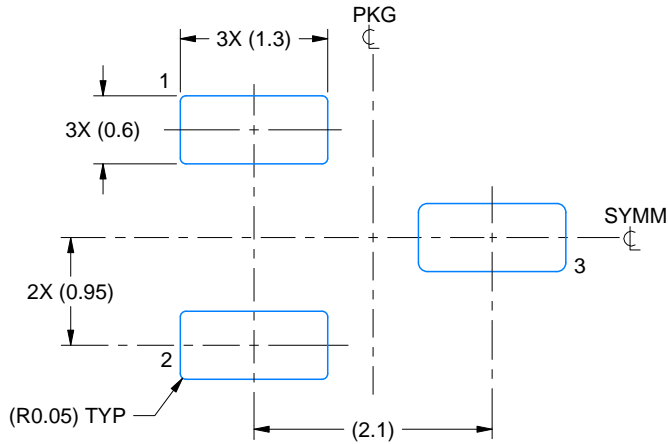

LAND PATTERN EXAMPLE
SCALE:15X

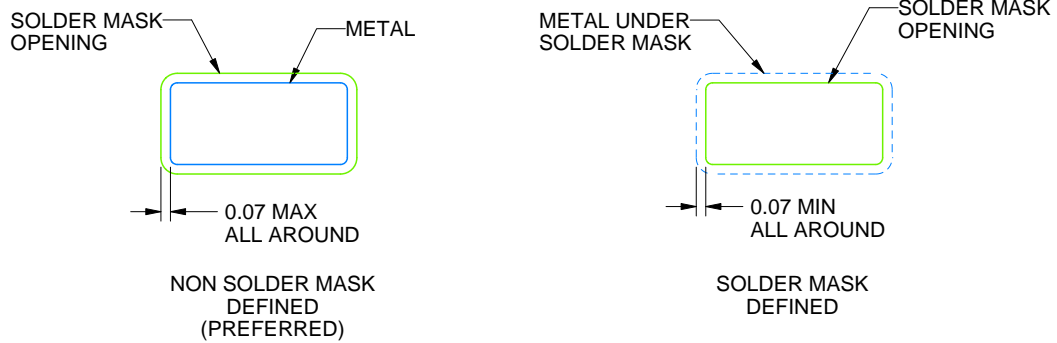

SOLDER MASK DETAILS

4214838/F 08/2024

NOTES: (continued)

5. Publication IPC-7351 may have alternate designs.
6. Solder mask tolerances between and around signal pads can vary based on board fabrication site.

EXAMPLE STENCIL DESIGN

DBZ0003A

SOT-23 - 1.12 mm max height

SMALL OUTLINE TRANSISTOR

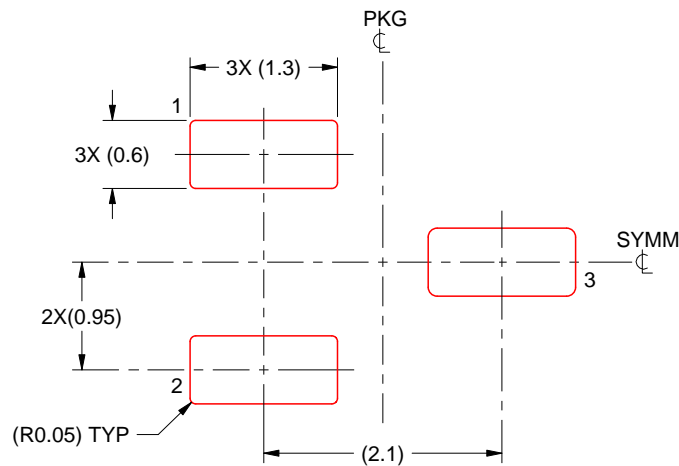

SOLDER PASTE EXAMPLE
BASED ON 0.125 THICK STENCIL
SCALE:15X

4214838/F 08/2024

NOTES: (continued)

7. Laser cutting apertures with trapezoidal walls and rounded corners may offer better paste release. IPC-7525 may have alternate design recommendations.
8. Board assembly site may have different recommendations for stencil design.

LPG0003A



PACKAGE OUTLINE

TO-92 - 5.05 mm max height

TRANSISTOR OUTLINE

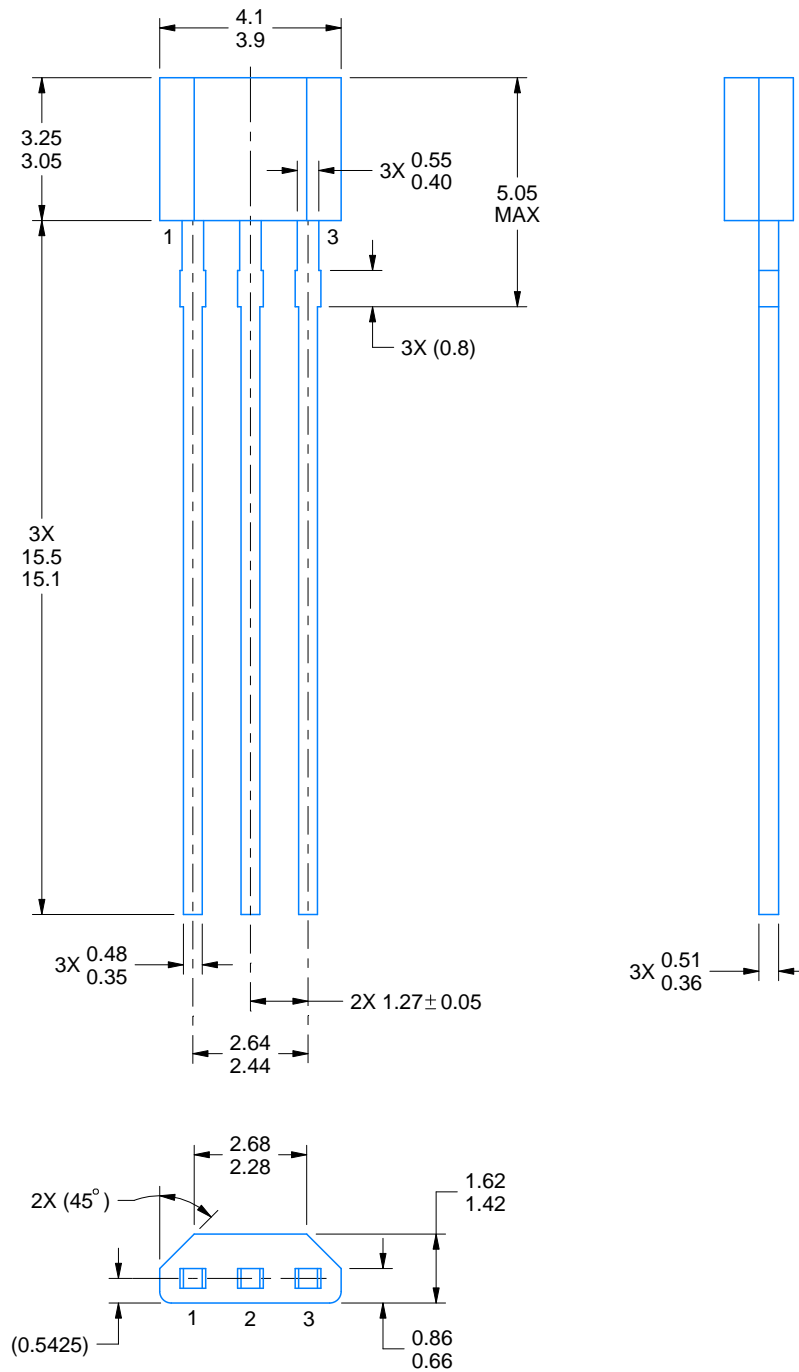

4221343/C 01/2018

NOTES:

1. All linear dimensions are in millimeters. Any dimensions in parenthesis are for reference only. Dimensioning and tolerancing per ASME Y14.5M.
2. This drawing is subject to change without notice.

EXAMPLE BOARD LAYOUT

LPG0003A

TO-92 - 5.05 mm max height

TRANSISTOR OUTLINE

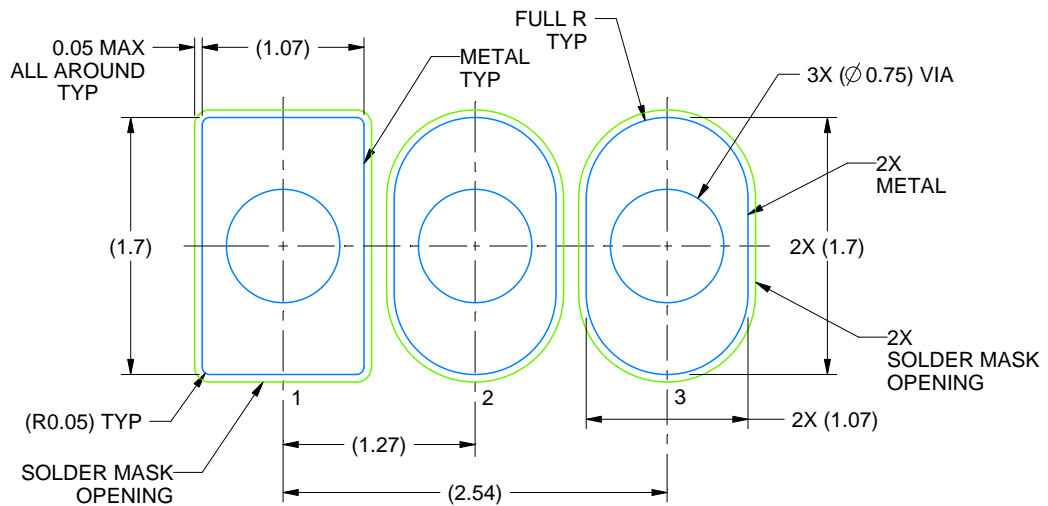

LAND PATTERN EXAMPLE
NON-SOLDER MASK DEFINED
SCALE:20X

4221343/C 01/2018

TAPE SPECIFICATIONS

LPG0003A

TO-92 - 5.05 mm max height

TRANSISTOR OUTLINE

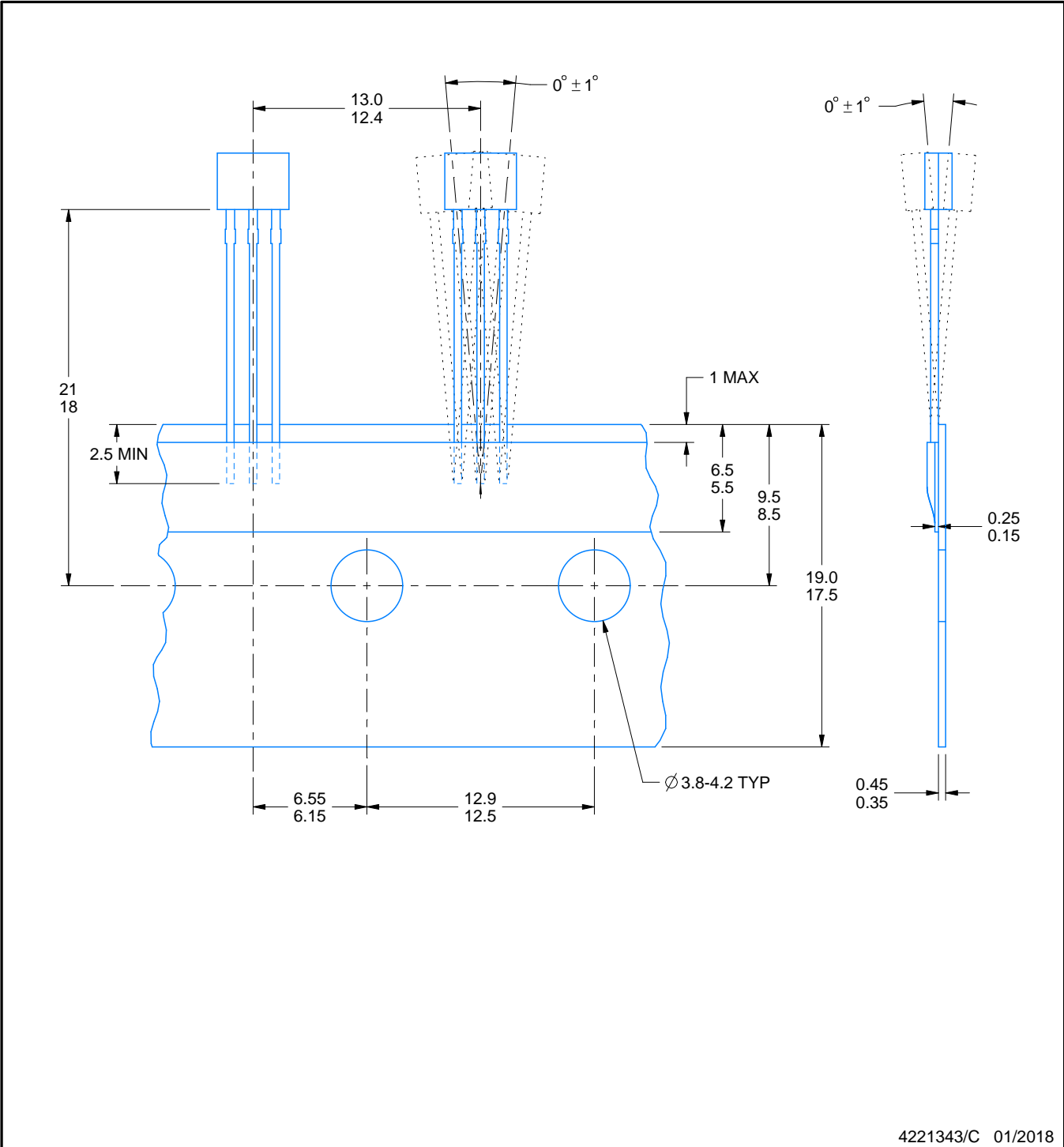

4221343/C 01/2018

重要なお知らせと免責事項

TI は、技術データと信頼性データ (データシートを含みます)、設計リソース (リファレンス デザインを含みます)、アプリケーションや設計に関する各種アドバイス、Web ツール、安全性情報、その他のリソースを、欠陥が存在する可能性のある「現状のまま」提供しており、商品性および特定目的に対する適合性の黙示保証、第三者の知的財産権の非侵害保証を含むいかなる保証も、明示的または黙示的にかかわらず拒否します。

これらのリソースは、TI 製品を使用する設計の経験を積んだ開発者への提供を意図したものです。(1) お客様のアプリケーションに適した TI 製品の選定、(2) お客様のアプリケーションの設計、検証、試験、(3) お客様のアプリケーションに該当する各種規格や、その他のあらゆる安全性、セキュリティ、規制、または他の要件への確実な適合に関する責任を、お客様のみが単独で負うものとし、

上記の各種リソースは、予告なく変更される可能性があります。これらのリソースは、リソースで説明されている TI 製品を使用するアプリケーションの開発の目的でのみ、TI はその使用をお客様に許諾します。これらのリソースに関して、他の目的で複製することや掲載することは禁止されています。TI や第三者の知的財産権のライセンスが付与されている訳ではありません。お客様は、これらのリソースを自身で使用した結果発生するあらゆる申し立て、損害、費用、損失、責任について、TI およびその代理人を完全に補償するものとし、TI は一切の責任を拒否します。

TI の製品は、[TI の販売条件](#)、[TI の総合的な品質ガイドライン](#)、[ti.com](#) または TI 製品などに関連して提供される他の適用条件に従い提供されます。TI がこれらのリソースを提供することは、適用される TI の保証または他の保証の放棄の拡大や変更を意味するものではありません。TI がカスタム、またはカスタマー仕様として明示的に指定していない限り、TI の製品は標準的なカタログに掲載される汎用機器です。

お客様がいかなる追加条項または代替条項を提案する場合も、TI はそれらに異議を唱え、拒否します。

Copyright © 2026, Texas Instruments Incorporated

最終更新日 : 2025 年 10 月