

DRV8770 : 100V ブラシ付き DC ゲート・ドライバ

1 特長

- 100V H ブリッジ・ゲート・ドライバ
 - N チャンネル MOSFET (NMOS) を駆動
 - ゲート・ドライバ電源 (GVDD): 5~20V
 - MOSFET 電源 (SHx) をサポート: 最大 100V
- ブートストラップ・ダイオードを内蔵
- 反転および非反転 INLx 入力をサポート (QFN パッケージ)
- ブートストラップ・ゲート駆動アーキテクチャ
 - 750mA のソース電流
 - 1.5A のシンク電流
- 最大 15S のバッテリー駆動アプリケーションをサポート
- SHx ピンの低リーク電流 (55µA 未満)
- BSTx 電圧の絶対最大定格: 115V
- SHx ピンで -22V までの負過渡電圧をサポート
- DT ピンでデッドタイムを調整可能 (QFN パッケージ)
- 200ns の固定デッドタイム挿入 (TSSOP パッケージ)
- 3.3V および 5V ロジック入力 (絶対最大定格 20V) をサポート
- 4ns (代表値) の伝搬遅延マッチング
- 小型の QFN および TSSOP パッケージおよびフットプリント
- パワー・ブロックによる効率的なシステム設計
- 保護機能内蔵
 - BST 低電圧誤動作防止 (BSTUV)
 - GVDD 低電圧 (GVDDUV)

2 アプリケーション

- 電動アシスト自転車、電動スクーター、E モビリティ
- コードレス園芸用器具および電動工具、芝刈り機
- コードレス掃除機
- ドローン、ロボティクス、ラジコン玩具
- 産業用および物流用ロボット
- 電動工具

3 概要

DRV8770 デバイスは 2 個のハーフブリッジ・ゲート・ドライバを搭載しており、それぞれがハイサイドとローサイドの各 N チャンネル・パワー MOSFET を駆動する能力があります。GVDD がローサイド MOSFET のゲートを駆動する一方、内蔵ブートストラップ・ダイオードと外付けコンデンサはハイサイド MOSFET のための適切なゲート駆動電圧を生成します。このゲート駆動アーキテクチャは最大でソース 750mA、シンク 1.5A のゲート駆動電流をサポートしています。

ゲート駆動ピンの高い許容電圧はシステムの堅牢性を高めます。SHx 位相ピンは大きな負電圧過渡に耐えます。一方、ハイサイド・ゲート・ドライバ電源は BSTx および GHx ピンのさらに大きな正電圧過渡 (絶対最大定格電圧 115V) に対応できます。伝搬遅延が短く、遅延マッチング仕様によりデッドタイムの要件が最小化されるため、さらに効率が向上します。GVDD と BST の低電圧誤動作防止による低電圧保護機能がローサイドとハイサイドの両方に備わっています。

製品情報(1)

部品番号	パッケージ	本体サイズ (公称)
DRV8770PW	TSSOP (20)	6.40mm × 4.40mm
DRV8770RGE	VQFN (24)	4.00mm × 4.00mm

(1) 利用可能なパッケージについては、このデータシートの末尾にある注文情報を参照してください。

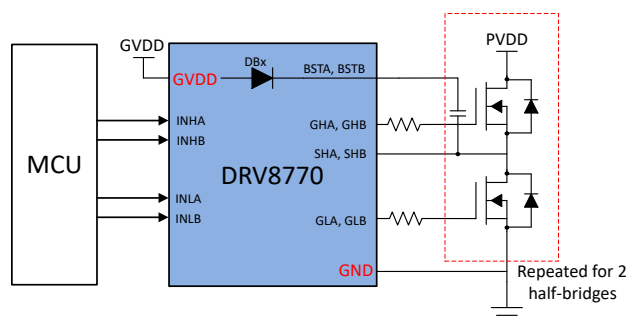

概略回路図 (DRV8770)



Table of Contents

1 特長	1	8 Application and Implementation	14
2 アプリケーション	1	8.1 Application Information.....	14
3 概要	1	8.2 Typical Application.....	14
4 Revision History	2	9 Power Supply Recommendations	17
5 Pin Configuration and Functions	3	9.1 Bulk Capacitance Sizing.....	17
6 Specifications	5	10 Layout	18
6.1 Absolute Maximum Ratings	5	10.1 Layout Example.....	18
6.2 ESD Ratings Comm	5	10.2 Layout Guidelines.....	18
6.3 Recommended Operating Conditions	5	11 Device and Documentation Support	19
6.4 Thermal Information	6	11.1 Receiving Notification of Documentation Updates..	19
6.5 Electrical Characteristics	6	11.2 サポート・リソース.....	19
6.6 Typical Characteristics.....	8	11.3 Trademarks.....	19
7 Detailed Description	9	11.4 Electrostatic Discharge Caution.....	19
7.1 Overview.....	9	11.5 Glossary.....	19
7.2 Functional Block Diagram.....	9	12 Mechanical, Packaging, and Orderable	
7.3 Feature Description.....	9	Information	19
7.4 Device Functional Modes.....	13		

4 Revision History

資料番号末尾の英字は改訂を表しています。その改訂履歴は英語版に準じています。

DATE	REVISION	NOTES
July 2021	*	Initial Release

5 Pin Configuration and Functions



图 5-1. DRV8770 RGE Package 24-Pin VQFN With Exposed Thermal Pad Top View

表 5-1. Pin Functions—24-Pin DRV8770 Device

PIN		TYPE ⁽¹⁾	DESCRIPTION
NAME	NO.		
BSTA	20	O	Bootstrap output pin. Connect capacitor between BSTA and SHA
BSTB	17	O	Bootstrap output pin. Connect capacitor between BSTB and SHB
DT	21	I	Deadtime input pin. Connect resistor to ground for variable deadtime, fixed deadtime when left it floating
GHA	19	O	High-side gate driver output. Connect to the gate of the high-side power MOSFET.
GHB	16	O	High-side gate driver output. Connect to the gate of the high-side power MOSFET.
GLA	11	O	Low-side gate driver output. Connect to the gate of the low-side power MOSFET.
GLB	10	O	Low-side gate driver output. Connect to the gate of the low-side power MOSFET.
GND	6	PWR	Device ground.
GVDD	4	PWR	Gate driver power supply input. Connect a X5R or X7R, GVDD-rated ceramic and greater then or equal to 10-uF local capacitance between the GVDD and GND pins.
INHA	22	I	High-side gate driver control input. This pin controls the output of the high-side gate driver.
INHB	23	I	High-side gate driver control input. This pin controls the output of the high-side gate driver.
INLA	1	I	Low-side gate driver control input. This pin controls the output of the low-side gate driver.
INLB	2	I	Low-side gate driver control input. This pin controls the output of the low-side gate driver.
MODE	5	I	Mode Input controls polarity of GLx compared to INLx inputs. Mode pin floating: GLx output polarity same(Non-Inverted) as INLx input Mode pin to GVDD: GLx output polarity inverted compared to INLx input
NC	7, 8	NC	No internal connection. This pin can be left floating or connected to system ground.
RSVD1, RSVD2, RSVD3, RSVD5, RSVD6	3, 9, 13, 14, 24	I	TI reserved pin. Leave pin floating.
RSVD4	12	I	TI reserved pin. Connect to GND
SHA	18	I	High-side source sense input. Connect to the high-side power MOSFET source.
SHB	15	I	High-side source sense input. Connect to the high-side power MOSFET source.

(1) PWR = power, I = input, O = output, NC = no connection

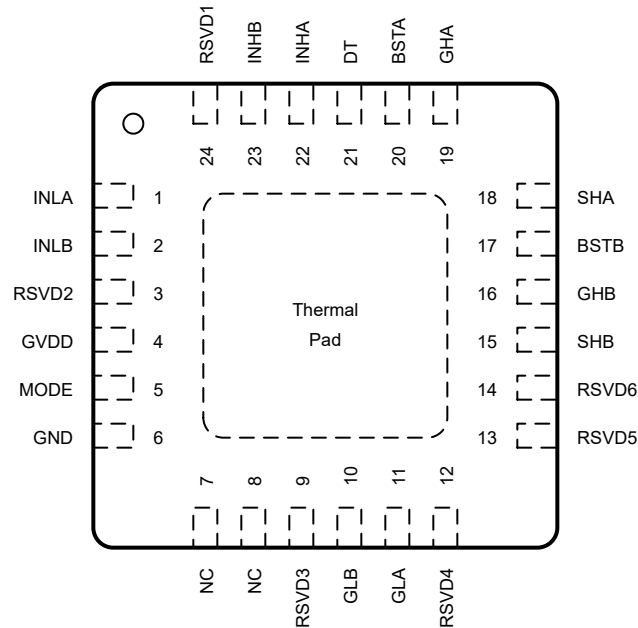

图 5-2. DRV8770 PW Package 20-Pin TSSOP Top View

表 5-2. Pin Functions—20-Pin DRV8770 Device

PIN		TYPE ⁽¹⁾	DESCRIPTION
NAME	NO.		
BSTA	20	O	Bootstrap output pin. Connect capacitor between BSTA and SHA
BSTB	17	O	Bootstrap output pin. Connect capacitor between BSTB and SHB
GHA	19	O	High-side gate driver output. Connect to the gate of the high-side power MOSFET.
GHB	16	O	High-side gate driver output. Connect to the gate of the high-side power MOSFET.
GLA	11	O	Low-side gate driver output. Connect to the gate of the low-side power MOSFET.
GLB	10	O	Low-side gate driver output. Connect to the gate of the low-side power MOSFET.
GND	8	PWR	Device ground.
GVDD	7	PWR	Gate driver power supply input. Connect a X5R or X7R, GVDD-rated ceramic and greater than or equal to 10-uF local capacitance between the GVDD and GND pins.
INHA	1	I	High-side gate driver control input. This pin controls the output of the high-side gate driver.
INHB	2	I	High-side gate driver control input. This pin controls the output of the high-side gate driver.
INLA	4	I	Low-side gate driver control input. This pin controls the output of the low-side gate driver.
INLB	5	I	Low-side gate driver control input. This pin controls the output of the low-side gate driver.
RSVD1, RSVD2, RSVD3, RSVD5, RSVD6	3, 6, 9, 13, 14	I	TI reserved pin. Leave pin floating.
RSVD4	12	I	TI reserved pin. Connect to GND
SHA	18	I	High-side source sense input. Connect to the high-side power MOSFET source.
SHB	15	I	High-side source sense input. Connect to the high-side power MOSFET source.

(1) PWR = power, I = input, O = output, NC = no connection

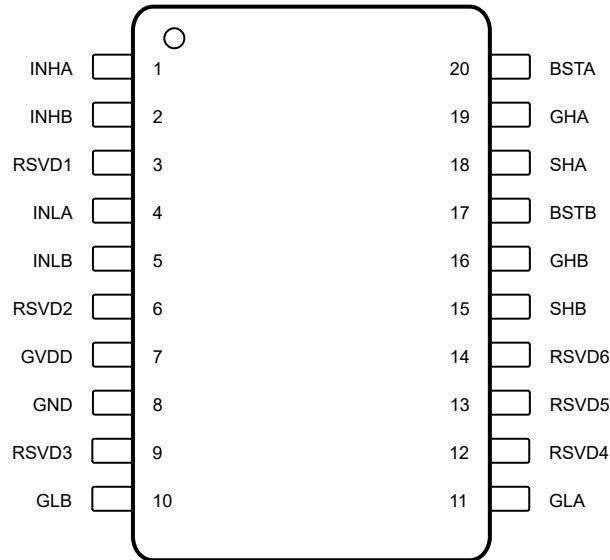
6 Specifications

6.1 Absolute Maximum Ratings

over operating temperature range (unless otherwise noted)⁽¹⁾

		MIN	MAX	UNIT
Gate driver regulator pin voltage	GVDD	-0.3	21.5	V
Bootstrap pin voltage	BSTx	-0.3	115	V
Bootstrap pin voltage	BSTx with respect to SHx	-0.3	21.5	V
Logic pin voltage	INHx, INLx, MODE, DT	-0.3	V _{GVDD} +0.3	V
High-side gate drive pin voltage	GHx	-22	115	V
High-side gate drive pin voltage	GHx with respect to SHx	-0.3	22	V
Transient 500-ns high-side gate drive pin voltage	GHx with respect to SHx	-5	22	V
Low-side gate drive pin voltage	GLx	-0.3	V _{GVDD} +0.3	V
Transient 500-ns low-side gate drive pin voltage	GLx	-5	V _{GVDD} +0.3	V
High-side source pin voltage	SHx	-22	100	V
Ambient temperature, T _A		-40	125	°C
Junction temperature, T _J		-40	150	°C
Storage temperature, T _{stg}		-65	150	°C

- (1) Stresses beyond those listed under *Absolute Maximum Rating* may cause permanent damage to the device. These are stress ratings only, which do not imply functional operation of the device at these or any other conditions beyond those indicated under *Recommended Operating Condition*. Exposure to absolute-maximum-rated conditions for extended periods may affect device reliability.

6.2 ESD Ratings Comm

			VALUE	UNIT
V _(ESD)	Electrostatic discharge	Human body model (HBM), per ANSI/ESDA/JEDEC JS-001 ⁽¹⁾	±1000	V
		Charged device model (CDM), per JEDEC specification JESD22-C101 ⁽²⁾	±250	

- (1) JEDEC document JEP155 states that 500-V HBM allows safe manufacturing with a standard ESD control process.
 (2) JEDEC document JEP157 states that 250-V CDM allows safe manufacturing with a standard ESD control process.

6.3 Recommended Operating Conditions

over operating temperature range (unless otherwise noted)

			MIN	NOM	MAX	UNIT
V _{GVDD}	Power supply voltage	GVDD	5		20	V
V _{SHx}	High-side source pin voltage	SHx	-2		85	V
V _{SHx}	Transient 2μs high-side source pin voltage	SHx	-22		85	V
V _{BST}	Bootstrap pin voltage	BSTx	5		105	V
V _{BST}	Bootstrap pin voltage	BSTx with respect to SHx	5		20	V
V _{IN}	Logic input voltage	INHx, INLx, MODE, DT	0		V _{GVDD}	V
f _{PWM}	PWM frequency	INHx, INLx	0		200	kHz
V _{SHSL}	Slew rate on SHx pin				2	V/ns
C _{BOOT} ⁽¹⁾	Capacitor between BSTx and SHx				1	μF
T _A	Operating ambient temperature		-40		125	°C
T _J	Operating junction temperature		-40		150	°C

- (1) Current flowing through boot diode (D_{BOOT}) needs to be limited for C_{BOOT} > 1μF

6.4 Thermal Information

THERMAL METRIC ⁽¹⁾		DRV8770		UNIT
		PW (TSSOP)	RGE (VQFN)	
		20 PINS	24 PINS	
R _{θJA}	Junction-to-ambient thermal resistance	97.4	49.3	°C/W
R _{θJC(top)}	Junction-to-case (top) thermal resistance	38.3	42.5	°C/W
R _{θJB}	Junction-to-board thermal resistance	48.8	26.5	°C/W
Ψ _{JT}	Junction-to-top characterization parameter	4.3	2.2	°C/W
Ψ _{JB}	Junction-to-board characterization parameter	48.4	26.4	°C/W
R _{θJC(bot)}	Junction-to-case (bottom) thermal resistance	N/A	11.5	°C/W

(1) For more information about traditional and new thermal metrics, see the [Semiconductor and IC Package Thermal Metrics](#) application report.

6.5 Electrical Characteristics

4.8 V ≤ V_{GVDD} ≤ 20 V, -40°C ≤ T_J ≤ 150°C (unless otherwise noted)

PARAMETER		TEST CONDITIONS	MIN	TYP	MAX	UNIT
POWER SUPPLIES (GVDD, BSTx)						
I _{GVDD}	GVDD standby mode current	INHx = INLx = 0; V _{BSTx} = V _{GVDD}	400	800	1400	μA
	GVDD active mode current	INHx = INLx = Switching @20kHz; V _{BSTx} = V _{GVDD} ; NO FETs connected	400	825	1400	μA
IL _{BSx}	Bootstrap pin leakage current	V _{BSTx} = V _{SHx} = 85V; V _{GVDD} = 0V	2	4	7	μA
IL _{BS_TRAN}	Bootstrap pin active mode transient leakage current	INHx = Switching@20kHz	30	105	220	μA
IL _{BS_DC}	Bootstrap pin active mode leakage static current	INHx = High	30	85	150	μA
IL _{SHx}	High-side source pin leakage current	INHx = INLx = 0; V _{BSTx} - V _{SHx} = 12V; V _{SHx} = 0 to 85V	30	55	80	μA
LOGIC-LEVEL INPUTS (INHx, INLx, MODE)						
V _{IL_MODE}	Input logic low voltage	Mode pin			0.6	V
V _{IL}	Input logic low voltage	INLx, INHx pins			0.8	V
V _{IH_MODE}	Input logic high voltage	Mode pin	3.7			V
V _{IH}	Input logic high voltage	INLx, INHx pins	2.0			V
V _{HYS_MODE}	Input hysteresis	Mode pin	1600	2000	2400	mV
V _{HYS}	Input hysteresis	INLx, INHx pins	40	100	260	mV
I _{IL_INLx}	INLx Input logic low current	V _{PIN} (Pin Voltage) = 0 V; INLx in non-inverting mode	-1	0	1	μA
		V _{PIN} (Pin Voltage) = 0 V; INLx in inverting mode	5	20	30	μA
I _{IH_INLx}	INLx Input logic high current	V _{PIN} (Pin Voltage) = 5 V; INLx in non-inverting mode	5	20	30	μA
		V _{PIN} (Pin Voltage) = 5 V; INLx in inverting mode	0	0.5	1.5	μA
I _{IL}	INHx, MODE Input logic low current	V _{PIN} (Pin Voltage) = 0 V;	-1	0	1	μA
I _{IH}	INHx, MODE Input logic high current	V _{PIN} (Pin Voltage) = 5 V;	5	20	30	μA
R _{PD_INHx}	INHx Input pulldown resistance	To GND	120	200	280	kΩ
R _{PD_INLx}	INLx Input pulldown resistance	To GND, INLx in non-inverting mode	120	200	280	kΩ
R _{PU_INLx}	INLx Input pullup resistance	To INT_5V, INLx in inverting mode	120	200	280	kΩ
R _{PD_MODE}	MODE Input pulldown resistance	To GND	120	200	280	kΩ
GATE DRIVERS (GHx, GLx, SHx, SLx)						

4.8 V ≤ V_{GVDD} ≤ 20 V, -40°C ≤ T_J ≤ 150°C (unless otherwise noted)

PARAMETER		TEST CONDITIONS	MIN	TYP	MAX	UNIT
V _{GHx_LO}	High-side gate drive low level voltage	I _{GLx} = -100 mA; V _{GVDD} = 12V; No FETs connected	0	0.15	0.35	V
V _{GHx_HI}	High-side gate drive high level voltage (V _{BSTx} - V _{GHx})	I _{GHx} = 100 mA; V _{GVDD} = 12V; No FETs connected	0.3	0.6	1.2	V
V _{GLx_LO}	Low-side gate drive low level voltage	I _{GLx} = -100 mA; V _{GVDD} = 12V; No FETs connected	0	0.15	0.35	V
V _{GLx_HI}	Low-side gate drive high level voltage (V _{GVDD} - V _{GHx})	I _{GHx} = 100 mA; V _{GVDD} = 12V; No FETs connected	0.3	0.6	1.2	V
I _{DRIVEP_HS}	High-side peak source gate current	GHx-SHx = 12V	400	750	1200	mA
I _{DRIVEN_HS}	High-side peak sink gate current	GHx-SHx = 0V	850	1500	2100	mA
I _{DRIVEP_LS}	Low-side peak source gate current	GLx = 12V	400	750	1200	mA
I _{DRIVEN_LS}	Low-side peak sink gate current	GLx = 0V	850	1500	2100	mA
t _{PD}	Input to output propagation delay	INHx, INLx to GHx, GLx; V _{GVDD} = V _{BSTx} - V _{SHx} > 8V; SHx = 0V, No load on GHx and GLx	70	125	180	ns
t _{PD_match}	Matching propagation delay per phase	GHx turning OFF to GLx turning ON, GLx turning OFF to GHx turning ON; V _{GVDD} = V _{BSTx} - V _{SHx} > 8V; SHx = 0V, No load on GHx and GLx	-30	±4	30	ns
t _{PD_match}	Matching propagation delay phase to phase	GHx/GLx turning ON to GHy/GLy turning ON, GHx/GLx turning OFF to GHy/GLy turning OFF; V _{GVDD} = V _{BSTx} - V _{SHx} > 8V; SHx = 0V, No load on GHx and GLx	-30	±4	30	ns
t _{R_GLx}	GLx rise time (10% to 90%)	C _{LOAD} = 1000 pF; V _{GVDD} = V _{BSTx} - V _{SHx} > 8V; SHx = 0V	10	24	50	ns
t _{R_GHx}	GHx rise time (10% to 90%)	C _{LOAD} = 1000 pF; V _{GVDD} = V _{BSTx} - V _{SHx} > 8V; SHx = 0V	10	24	50	ns
t _{F_GLx}	GLx fall time (90% to 10%)	C _{LOAD} = 1000 pF; V _{GVDD} = V _{BSTx} - V _{SHx} > 8V; SHx = 0V	5	12	30	ns
t _{F_GHx}	GHx fall time (90% to 10%)	C _{LOAD} = 1000 pF; V _{GVDD} = V _{BSTx} - V _{SHx} > 8V; SHx = 0V	5	12	30	ns
t _{DEAD}	Gate drive dead time	DT pin connected to GND	150	215	280	ns
		40 kΩ between DT pin and GND	150	200	260	ns
		400 kΩ between DT pin and GND	1500	2000	2600	ns
t _{PW_MIN}	Minimum input pulse width on INHx, INLx that changes the output on GHx, GLx		40	70	150	ns
BOOTSTRAP DIODES						
V _{BOOTD}	Bootstrap diode forward voltage	I _{BOOT} = 100 μA	0.45	0.7	0.85	V
		I _{BOOT} = 100 mA	2	2.3	3.1	V
R _{BOOTD}	Bootstrap dynamic resistance (ΔV _{BOOTD} /ΔI _{BOOT})	I _{BOOT} = 100 mA and 80 mA	11	15	25	Ω
PROTECTION CIRCUITS						
V _{GVDDUV}	Gate Driver Supply undervoltage lockout (GVDDUV)	Supply rising	4.45	4.6	4.7	V
		Supply falling	4.2	4.35	4.4	V
V _{GVDDUV_HYS}	Gate Driver Supply UV hysteresis	Rising to falling threshold	250	280	310	mV
t _{GVDDUV}	Gate Driver Supply undervoltage deglitch time		5	10	13	μs
V _{BSTUV}	Boot Strap undervoltage lockout (V _{BSTx} - V _{SHx})	Supply rising	3.6	4.2	4.8	V
		Supply falling	3.5	4	4.5	V

$4.8\text{ V} \leq V_{\text{GVDD}} \leq 20\text{ V}$, $-40^{\circ}\text{C} \leq T_{\text{J}} \leq 150^{\circ}\text{C}$ (unless otherwise noted)

PARAMETER		TEST CONDITIONS	MIN	TYP	MAX	UNIT
$V_{\text{BSTUV_HYS}}$	Bootstrap UV hysteresis	Rising to falling threshold		200		mV
t_{BSTUV}	Bootstrap undervoltage deglitch time		6	10	22	μs

6.6 Typical Characteristics

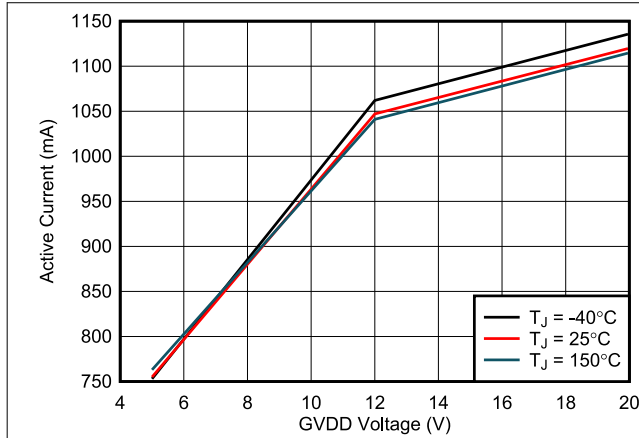

6-1. Supply Current Over GVDD Voltage

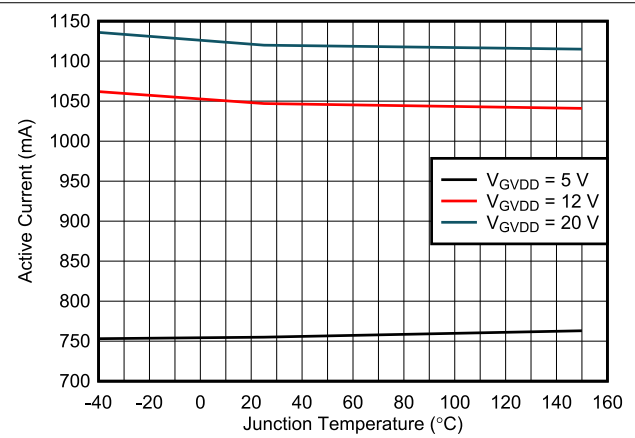

6-2. Supply Current Over Temperature

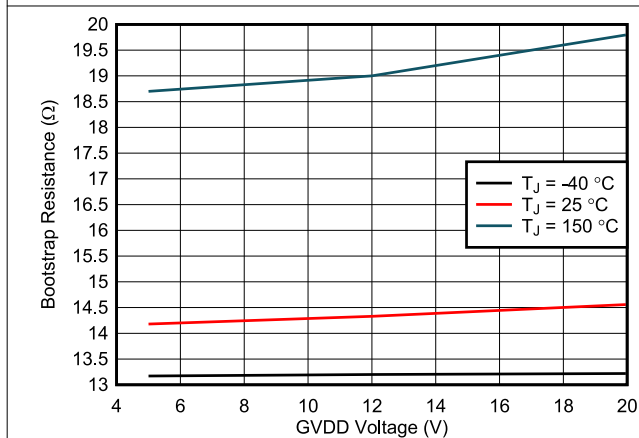

6-3. Bootstrap Resistance Over GVDD Voltage

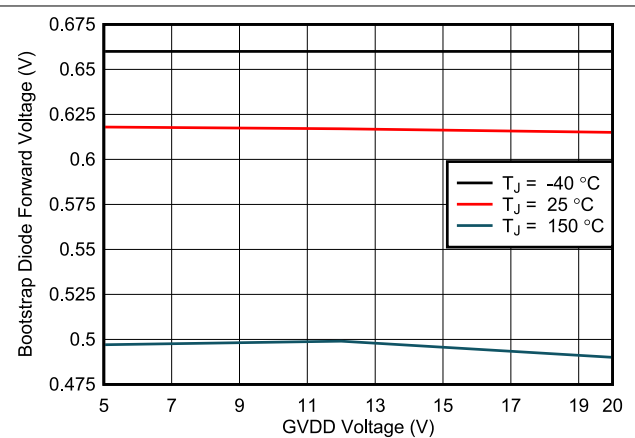

6-4. Bootstrap Diode Forward Voltage over GVDD Voltage

7 Detailed Description

7.1 Overview

The DRV8770 device is a gate driver for brushed DC motor drive applications. This device decreases system component count, reduces PCB area, and saves cost by integrating two independent half-bridge gate drivers and bootstrap diodes.

DRV8770 device integrates bootstrap diode used along with boot capacitor to generate voltage to drive high side N-channel MOSFET. The high-side and low-side gate drivers and can drive 750-mA source, 1.5-A sink currents with total 30-mA average output current. DRV8770 is available in 0.5-mm pitch QFN and 0.65 TSSOP surface-mount packages. The QFN size is 4 × 4 mm (0.5-mm pin pitch) for the 24-pin package, and TSSOP size is 6.5 × 6.4 mm (0.65-mm pin pitch) for the 20-pin package.

7.2 Functional Block Diagram

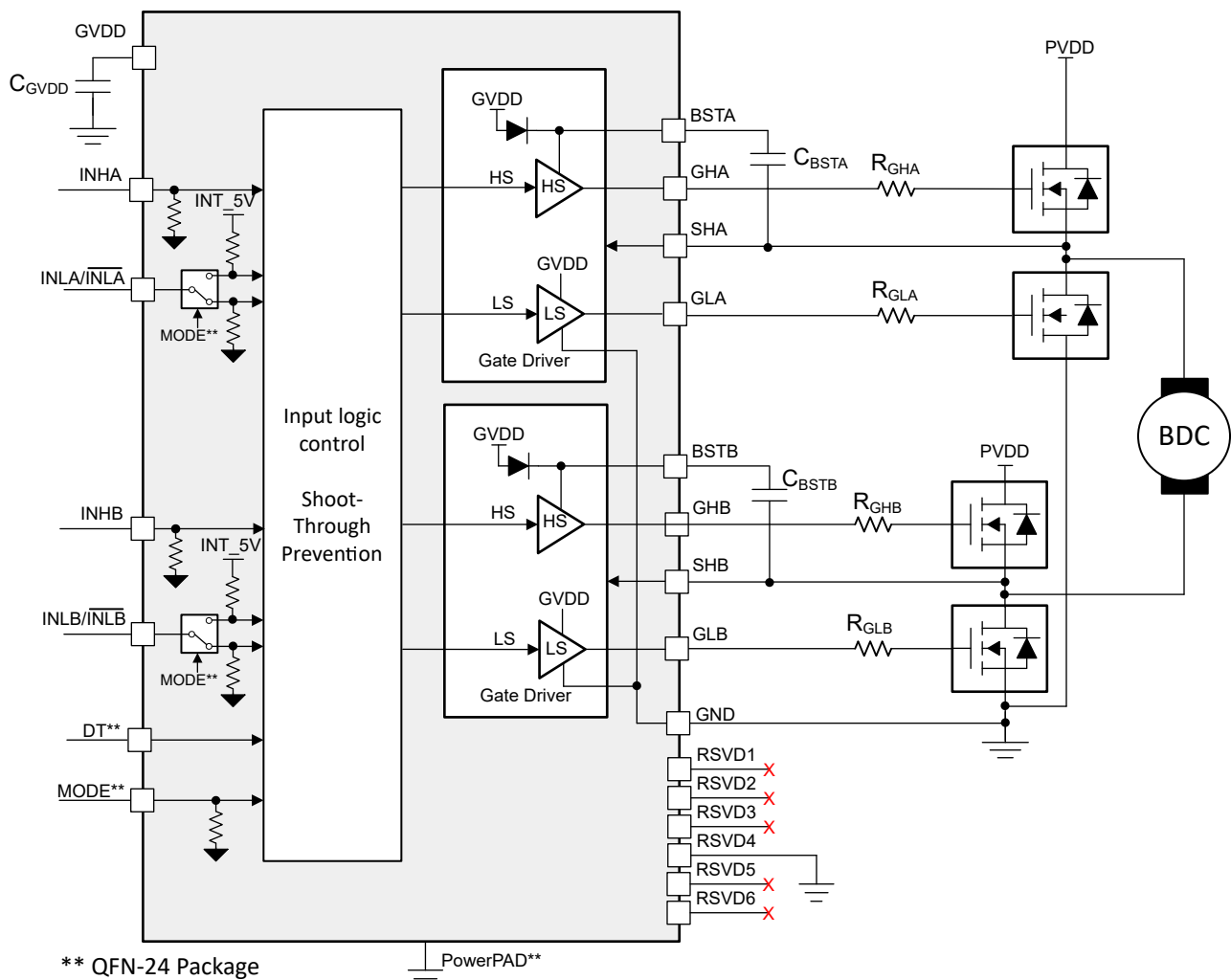

7-1. Block Diagram for DRV8770

7.3 Feature Description

7.3.1 Gate Drivers

The DRV8770 integrates two half-bridge gate drivers, each capable of driving high-side and low-side N-channel power MOSFETs. Input on GVDD provides the gate bias voltage for the low-side MOSFETs. The high voltage is generated using a bootstrap capacitor and GVDD supply. DRV8770 device integrates the bootstrap diode. The

half-bridge gate drivers can be used in combination to drive a brushed DC motor or separately to drive other types of loads.

7.3.1.1 Gate Drive Timings

7.3.1.1.1 Propagation Delay

The propagation delay time (t_{pd}) is measured as the time between an input logic edge to a detected output change. This time has two parts consisting of the input deglitcher delay and the delay through the analog gate drivers.

The input deglitcher prevents high-frequency noise on the input pins from affecting the output state of the gate drivers. The analog gate drivers have a small delay that contributes to the overall propagation delay of the device.

7.3.1.1.2 Deadtime and Cross-Conduction Prevention

In the DRV8770, high- and low-side inputs operate independently, with an exception to prevent cross conduction when high and low side are turned ON at same time. The DRV8770 turns OFF high- and low- side output to prevent shoot through when high- and low-side inputs are logic high at same time.

The DRV8770 also provides deadtime insertion to prevents both external MOSFETs of each power-stage from switching on at the same time. In devices with DT pin (QFN package device), deadtime can be linearly adjusted between 200 ns to 2000 ns by connecting resistor between DT and ground. When DT pin is connected to ground, fixed deadtime of 200 ns (typical value) is inserted. The value of resistor can be calculated using 式 1.

$$R_{DT}(k\Omega) = \frac{\text{Deadtime (ns)}}{5} \tag{1}$$

In device without DT pin (TSSOP package device), fixed deadtime of 200 ns (Typical value) is inserted to prevent high and low side gate output turning on at same time.

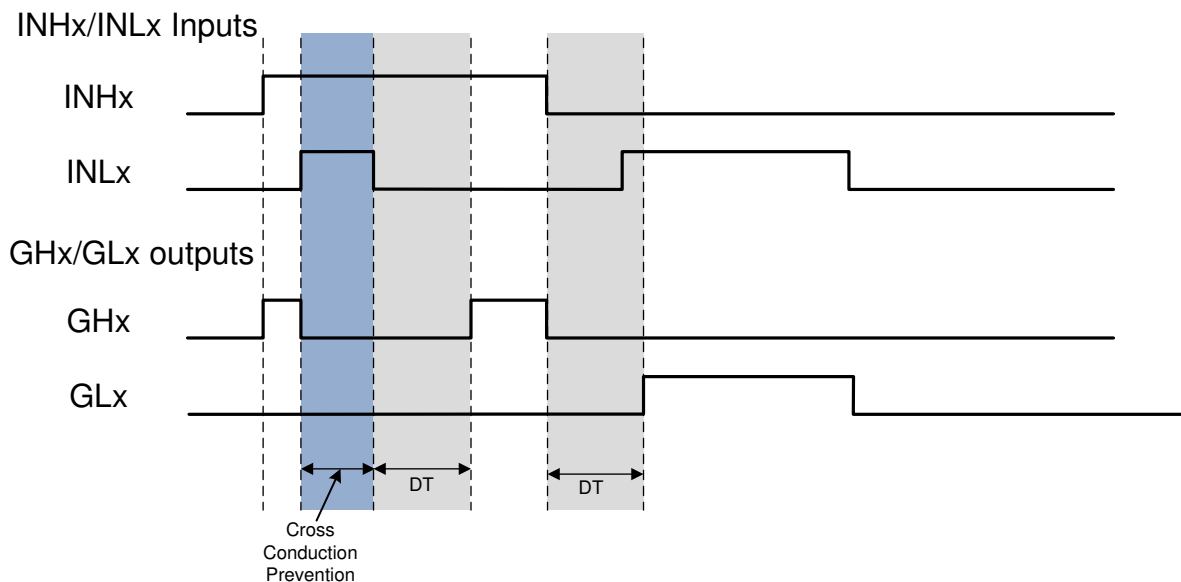

7-2. Cross Conduction Prevention and Deadtime Insertion

7.3.1.2 Mode (Inverting and non-inverting INLx)

The DRV8770 has flexibility of accepting different kind of inputs on INLx. In the QFN (RGE) package variant, the MODE pin provides option of GLx output inverted or non-inverted compared to polarity of signal on INLx pin. When the MODE pin is left floating, INLx is configured to be in non-inverting mode and GLx output is in phase

with INLx (see 7-3). When MODE pin is connected to GVDD, GLx output is out of phase with inputs (see 7-4). The TSSOP (PW) package variant does not have a MODE pin, so the INLx pins are inverted by default.

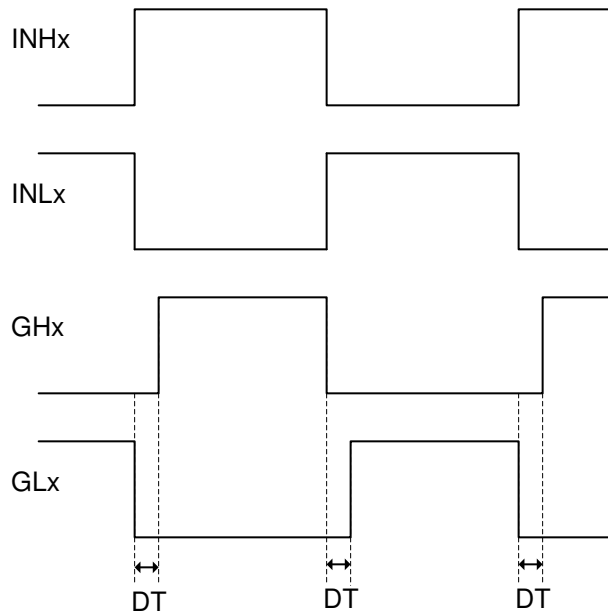

7-3. Non-Inverted INLx inputs (MODE = floating)

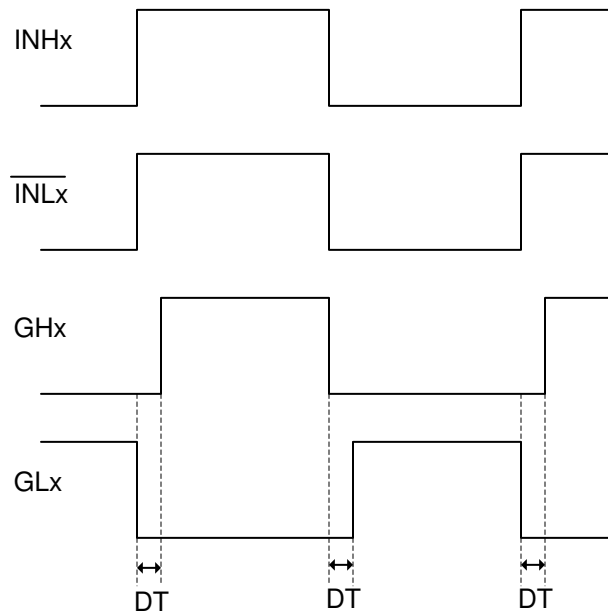

7-4. Inverted INLx inputs (MODE = GVDD or TSSOP package variant)

表 7-1 shows the states of the gate drivers and FET half bridge when MODE = floating.

表 7-1. Logic table when MODE = floating

INHx	INLx	GHx	GLx	Half Bridge State
0	0	L	L	Z, FETs disabled
0	1	L	H	L, low-side FET enabled
1	0	H	L	H, high-side FET enabled
1	1	L	L	Z, invalid state

表 7-2 shows the states of the gate drivers and FET half bridge for the inverted mode (MODE = GVDD or the default mode of the TSSOP package). In this mode, the INHx and INLx pins can be tied together to reduce the number of control signals from a microcontroller, as shown in 表 7-3. In this configuration, the device controls the deadtime as described in セクション 7.3.1.1.2.

表 7-2. Logic table when MODE = GVDD or TSSOP package variant

INHx	INLx	GHx	GLx	Half Bridge State
0	0	L	H	L, low-side FET enabled
0	1	L	L	Z, FETs disabled
1	0	L	L	Z, invalid state
1	1	H	L	H, high-side FET enabled

表 7-3. Logic table when INHx = INLx for MODE = GVDD or TSSOP package variant

INHx = INLx	GHx	GLx	Half Bridge State
0	L	H	L, low-side FET enabled
1	H	L	H, high-side FET enabled

7.3.2 Pin Diagrams

図 7-5 shows the input structure for the logic level pins INHx, INLx. INHx and INLx has passive pull down, so when inputs are floating the output of gate driver will be pulled low. 図 7-6 shows the input structure for the logic level pin inverted INLx. INLx in inverted mode has passive pull up, so when inputs are floating the output of gate driver will be pulled low.

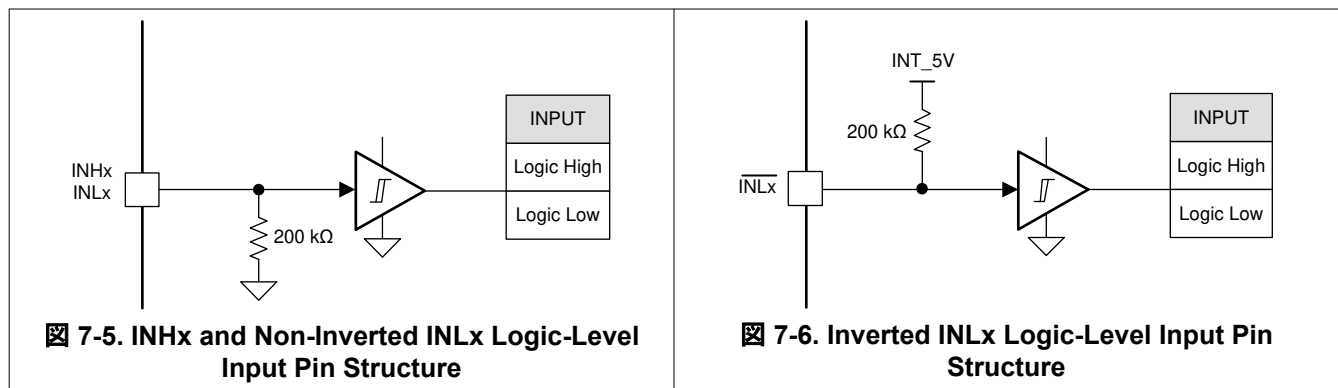

7.3.3 Gate Driver Protective Circuits

The DRV8770 is protected against BSTx undervoltage and GVDD undervoltage events.

表 7-4. Fault Action and Response

FAULT	CONDITION	GATE DRIVER	RECOVERY
V _{BSTx} undervoltage (BSTUV)	V _{BSTx} < V _{BSTUV}	GHx - Hi-Z	Automatic: V _{BSTx} > V _{BSTUV} and low to high PWM edge detected on INHx pin
GVDD undervoltage (GVDDUV)	V _{GVDD} < V _{GVDDUV}	Hi-Z	Automatic: V _{GVDD} > V _{GVDDUV}

7.3.3.1 V_{BSTx} Undervoltage Lockout (BSTUV)

The DRV8770 has separate voltage comparator to detect undervoltage condition for each phase. If at any time the supply voltage on the BSTx pin falls lower than the VBSTUV threshold, high side external MOSFETs of that particular phase is disabled by disabling (Hi-Z) GHx pin. Normal operation starts again when the BSTUV condition clears and low to high PWM edge is detected on INHx input on the same phase BSTUV was detected. BSTUV protection ensures that high side gate driver are not switched when BSTx pin has lower value.

7.3.3.2 GVDD Undervoltage Lockout (GVDDUV)

If at any time the voltage on the GVDD pin falls lower than the V_{GVDDUV} threshold voltage, all of the external MOSFETs are disabled. Normal operation starts again GVDDUV condition clears. GVDDUV protection ensures that gate driver are not switched when GVDD input is at lower value.

7.4 Device Functional Modes

Whenever the $GVDD > V_{GVDDUV}$ and $V_{BSTX} > V_{BSTUV}$ the device is in operating (active) mode, in this condition gate driver output GHx and GLX will follow respective inputs INHx and INLx.

8 Application and Implementation

Note

Information in the following applications sections is not part of the TI component specification, and TI does not warrant its accuracy or completeness. TI's customers are responsible for determining suitability of components for their purposes. Customers should validate and test their design implementation to confirm system functionality.

8.1 Application Information

The DRV8770 is primarily used for brushed DC motor control. The design procedures in the [セクション 8.2](#) section highlight how to use and configure the DRV8770.

8.2 Typical Application

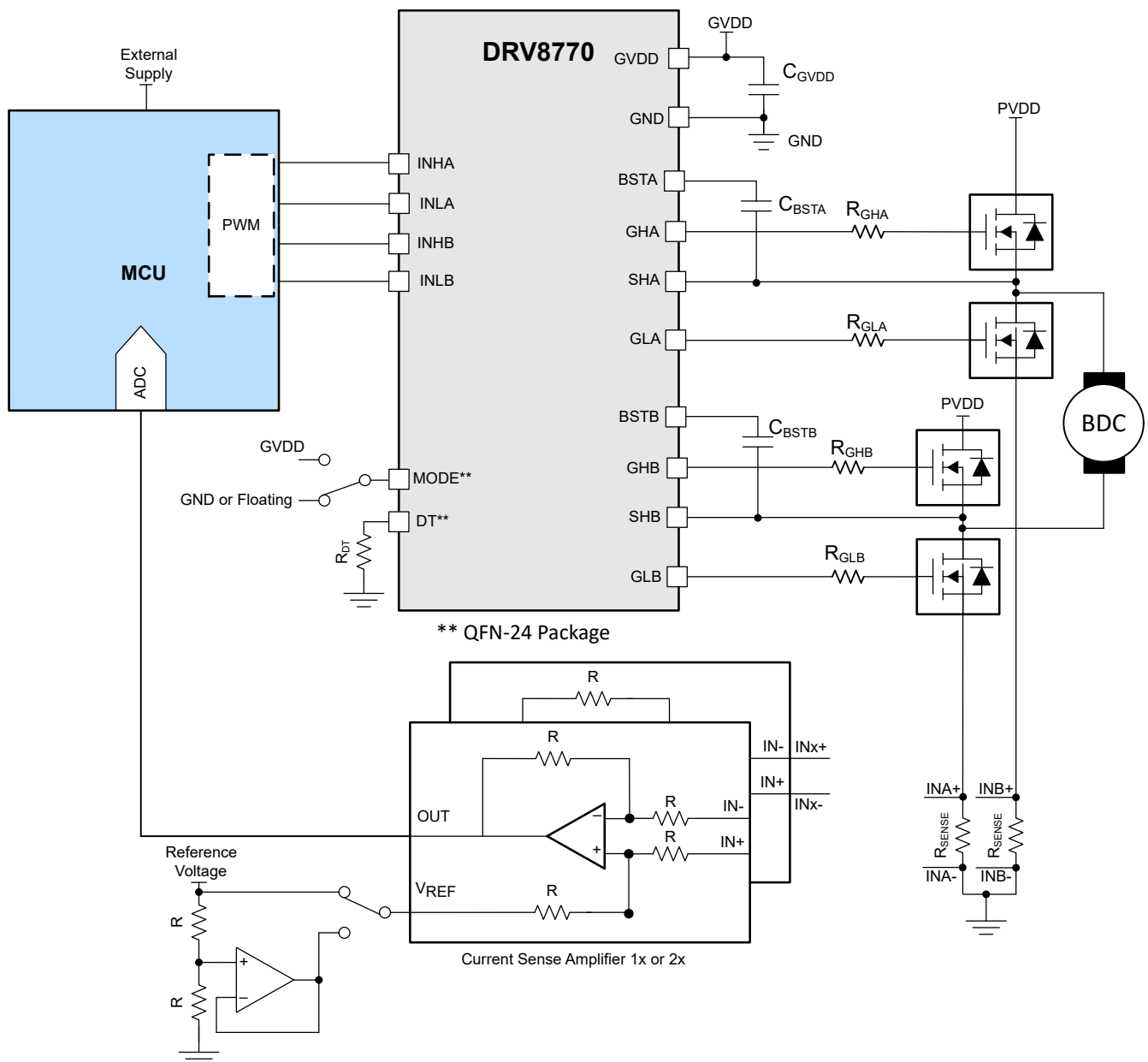

8-1. Application Schematic

8.2.1 Design Requirements

表 8-1 lists the example design input parameters for system design.

表 8-1. Design Parameters

EXAMPLE DESIGN PARAMETER	REFERENCE	EXAMPLE VALUE
MOSFET	-	CSD19532Q5B
Gate Supply Voltage	V_{GVDD}	12 V
Gate Charge	Q_G	48 nC

8.2.2 Detailed Design Procedure

Bootstrap Capacitor and GVDD Capacitor Selection

The bootstrap capacitor must be sized to maintain the bootstrap voltage above the undervoltage lockout for normal operation. 式 2 calculates the maximum allowable voltage drop across the bootstrap capacitor:

$$\Delta V_{BSTX} = V_{GVDD} - V_{BOOTD} - V_{BSTUV} \quad (2)$$

$$= 12 \text{ V} - 0.85 \text{ V} - 4.5 \text{ V} = 6.65 \text{ V}$$

where

- V_{GVDD} is the supply voltage of the gate drive
- V_{BOOTD} is the forward voltage drop of the bootstrap diode
- V_{BSTUV} is the threshold of the bootstrap undervoltage lockout

In this example the allowed voltage drop across bootstrap capacitor is 6.65 V. It is generally recommended that ripple voltage on both the bootstrap capacitor and GVDD capacitor should be minimized as much as possible. Many of commercial, industrial, and automotive applications use ripple value between 0.5 V to 1 V.

The total charge needed per switching cycle can be estimated with 式 3:

$$Q_{TOT} = Q_G + \frac{I_{LBS_TRANS}}{f_{SW}} \quad (3)$$

$$= 48 \text{ nC} + 220 \mu\text{A}/20 \text{ kHz} = 50 \text{ nC} + 11 \text{ nC} = 59 \text{ nC}$$

where

- Q_G is the total MOSFET gate charge
- I_{LBS_TRAN} is the bootstrap pin leakage current
- f_{SW} is the is the PWM frequency

The minimum bootstrap capacitor can then be estimated as below assuming 1-V ΔV_{BSTX} :

$$C_{BST_MIN} = Q_{TOT} / \Delta V_{BSTX} \quad (4)$$

$$= 59 \text{ nC} / 1 \text{ V} = 59 \text{ nF}$$

The calculated value of minimum bootstrap capacitor is 59 nF. It should be noted that, this value of capacitance is needed at full bias voltage. In practice, the value of the bootstrap capacitor must be greater than calculated value to allow for situations where the power stage may skip pulse due to various transient conditions. It is recommended to use a 100 nF bootstrap capacitor in this example. It is also recommended to include enough margin and place the bootstrap capacitor as close to the BSTx and SHx pins as possible.

Note

If the bootstrap capacitor value (C_{BSTX}) is above 1 μF , then current flowing through internal bootstrap diode needs to be limited.

The local GVDD bypass capacitor must be greater than the value of bootstrap capacitor value (generally 10 times the bootstrap capacitor value).

$$C_{GVDD} \geq 10 \times C_{BSTX} \tag{5}$$

$$= 10 \times 100 \text{ nF} = 1 \mu\text{F}$$

For this example application, choose 1- μF C_{GVDD} capacitor. Choose a capacitor with a voltage rating at least twice the maximum voltage that it will be exposed to because most ceramic capacitors lose significant capacitance when biased. This value also improves the long term reliability of the system.

Gate Resistance Selection

The slew rate of the SHx connection will be dependent on the rate at which the gate of the external MOSFETs is controlled. The pull-up/pull-down strength of the DRV8770 is fixed internally, hence slew rate of gate voltage can be controlled with an external series gate resistor. In some applications the gate charge, which is load on gate driver device, is significantly larger than gate driver peak output current capability. In such applications external gate resistors can limit the peak output current of the gate driver. External gate resistors are also used to damp ringing and noise.

The specific parameters of the MOSFET, system voltage, and board parasitics will all affect the final slew rate, so generally selecting an optimal value or configuration of external gate resistor is an iterative process.

8.2.3 Application Curves

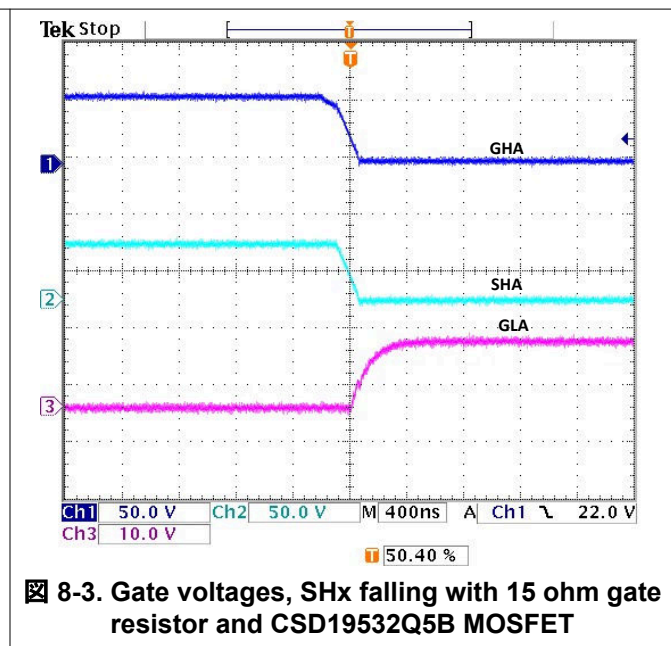
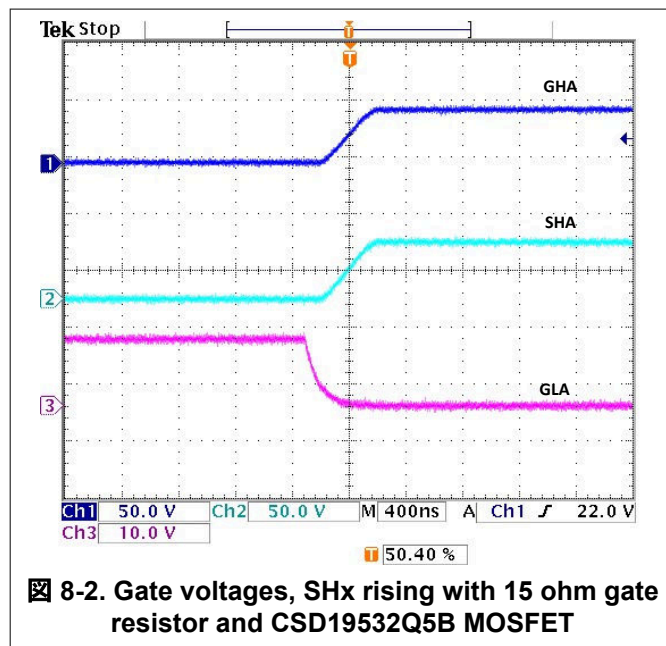

9 Power Supply Recommendations

The DRV8770 is designed to operate from an input voltage supply (GVDD) range from 4.8 V to 20 V. A local bypass capacitor should be placed between the GVDD and GND pins. This capacitor should be located as close to the device as possible. A low ESR, ceramic surface mount capacitor is recommended. It is recommended to use two capacitors across GVDD and GND: a low capacitance ceramic surface-mount capacitor for high frequency filtering placed very close to GVDD and GND pin, and another high capacitance value surface-mount capacitor for device bias requirements. In a similar manner, the current pulses delivered by the GHx pins are sourced from the BSTx pins. Therefore, capacitor across the BSTx to SHx is recommended, it should be high enough capacitance value capacitor to deliver GHx pulses.

9.1 Bulk Capacitance Sizing

Having appropriate local bulk capacitance is an important factor in motor drive system design. It is generally beneficial to have more bulk capacitance, while the disadvantages are increased cost and physical size. The amount of local capacitance depends on a variety of factors including:

- The highest current required by the motor system
- The power supply's type, capacitance, and ability to source current
- The amount of parasitic inductance between the power supply and motor system
- The acceptable supply voltage ripple
- Type of motor (brushed DC, brushless DC, stepper)
- The motor startup and braking methods

The inductance between the power supply and motor drive system will limit the rate current can change from the power supply. If the local bulk capacitance is too small, the system will respond to excessive current demands or dumps from the motor with a change in voltage. When adequate bulk capacitance is used, the motor voltage remains stable and high current can be quickly supplied.

The data sheet provides a recommended minimum value, but system level testing is required to determine the appropriate sized bulk capacitor.

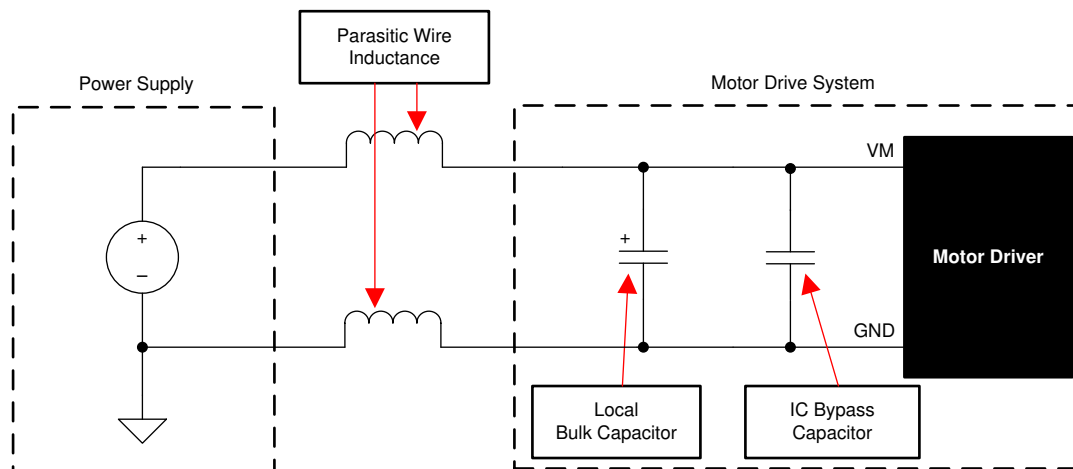

☒ 9-1. Motor Drive Supply Parasitics Example

10 Layout

10.1 Layout Example

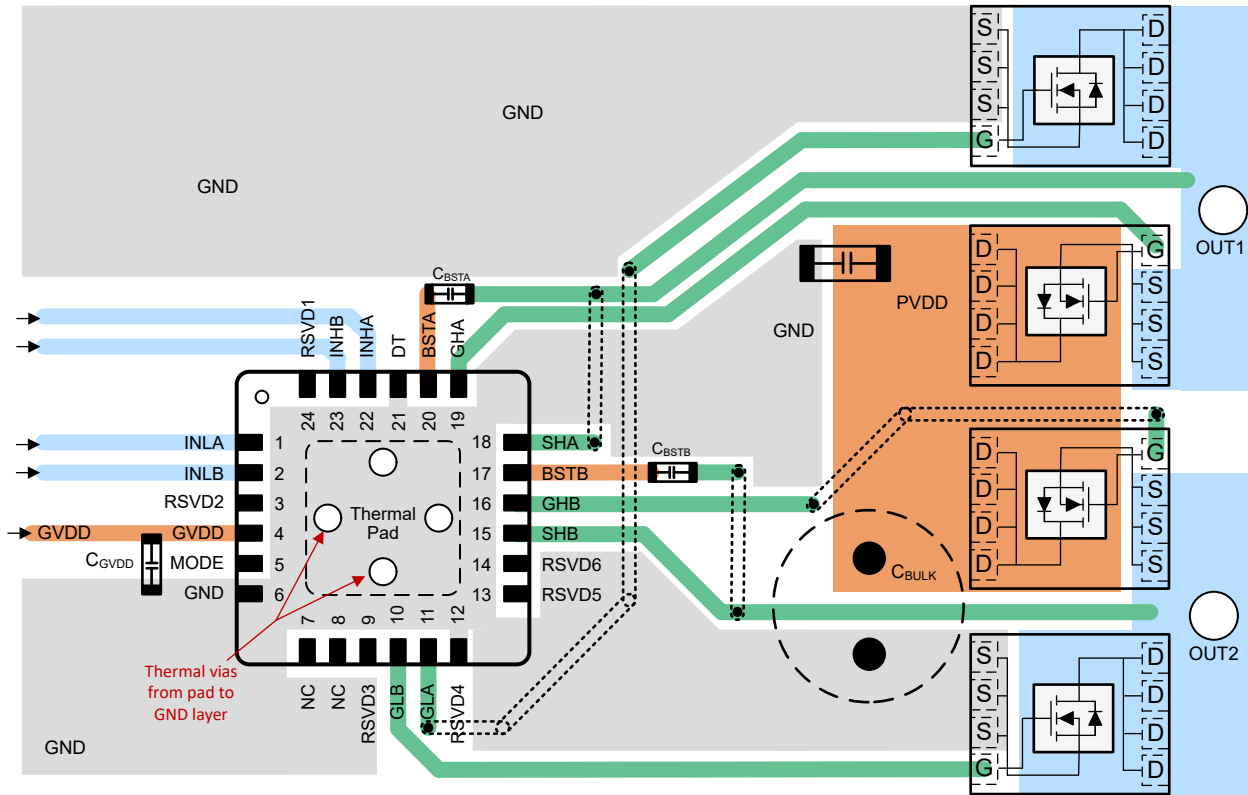

10.2 Layout Guidelines

- Low ESR/ESL capacitors must be connected close to the device between GVDD and GND and between BSTx and SHx pins to support high peak currents drawn from GVDD and BSTx pins during the turn-on of the external MOSFETs.
- To prevent large voltage transients at the drain of the top MOSFET, a low ESR electrolytic capacitor and a good quality ceramic capacitor must be connected between the high side MOSFET drain and ground.
- In order to avoid large negative transients on the switch node (SHx) pin, the parasitic inductances between the source of the high-side MOSFET and the source of the low-side MOSFET must be minimized.
- In order to avoid unexpected transients, the parasitic inductance of the GHx, SHx, and GLx connections must be minimized. Minimize the trace length and number of vias wherever possible. Minimum 10 mil and typical 15 mil trace width is recommended.
- Resistance between DT and GND must be placed as close as possible to device
- Place the gate driver as close to the MOSFETs as possible. Confine the high peak currents that charge and discharge the MOSFET gates to a minimal physical area by reducing trace length. This confinement decreases the loop inductance and minimize noise issues on the gate terminals of the MOSFETs.
- In QFN package device variants, NC pins can be connected to GND to increase ground connection between thermal pad and external ground plane.
- Refer to sections *General Routing Techniques and MOSFET Placement and Power Stage Routing* in [Application Report](#)

11 Device and Documentation Support

11.1 Receiving Notification of Documentation Updates

To receive notification of documentation updates, navigate to the device product folder on ti.com. In the upper right corner, click on *Alert me* to register and receive a weekly digest of any product information that has changed. For change details, review the revision history included in any revised document.

11.2 サポート・リソース

[TI E2E™ サポート・フォーラム](#)は、エンジニアが検証済みの回答と設計に関するヒントをエキスパートから迅速かつ直接得ることができる場所です。既存の回答を検索したり、独自の質問をしたりすることで、設計に必要な支援を迅速に得ることができます。

リンクされているコンテンツは、該当する貢献者により、現状のまま提供されるものです。これらは TI の仕様を構成するものではなく、必ずしも TI の見解を反映したものではありません。TI の[使用条件](#)を参照してください。

11.3 Trademarks

TI E2E™ is a trademark of Texas Instruments.

すべての商標は、それぞれの所有者に帰属します。

11.4 Electrostatic Discharge Caution



This integrated circuit can be damaged by ESD. Texas Instruments recommends that all integrated circuits be handled with appropriate precautions. Failure to observe proper handling and installation procedures can cause damage.

ESD damage can range from subtle performance degradation to complete device failure. Precision integrated circuits may be more susceptible to damage because very small parametric changes could cause the device not to meet its published specifications.

11.5 Glossary

[TI Glossary](#) This glossary lists and explains terms, acronyms, and definitions.

12 Mechanical, Packaging, and Orderable Information

The following pages include mechanical, packaging, and orderable information. This information is the most current data available for the designated devices. This data is subject to change without notice and revision of this document. For browser-based versions of this data sheet, refer to the left-hand navigation.

PACKAGING INFORMATION

Orderable part number	Status (1)	Material type (2)	Package Pins	Package qty Carrier	RoHS (3)	Lead finish/ Ball material (4)	MSL rating/ Peak reflow (5)	Op temp (°C)	Part marking (6)
DRV8770RGER	Active	Production	VQFN (RGE) 24	3000 LARGE T&R	Yes	SN	Level-1-260C-UNLIM	-40 to 125	8770
DRV8770RGER.A	Active	Production	VQFN (RGE) 24	3000 LARGE T&R	Yes	SN	Level-1-260C-UNLIM	-40 to 125	8770

(1) **Status:** For more details on status, see our [product life cycle](#).

(2) **Material type:** When designated, preproduction parts are prototypes/experimental devices, and are not yet approved or released for full production. Testing and final process, including without limitation quality assurance, reliability performance testing, and/or process qualification, may not yet be complete, and this item is subject to further changes or possible discontinuation. If available for ordering, purchases will be subject to an additional waiver at checkout, and are intended for early internal evaluation purposes only. These items are sold without warranties of any kind.

(3) **RoHS values:** Yes, No, RoHS Exempt. See the [TI RoHS Statement](#) for additional information and value definition.

(4) **Lead finish/Ball material:** Parts may have multiple material finish options. Finish options are separated by a vertical ruled line. Lead finish/Ball material values may wrap to two lines if the finish value exceeds the maximum column width.

(5) **MSL rating/Peak reflow:** The moisture sensitivity level ratings and peak solder (reflow) temperatures. In the event that a part has multiple moisture sensitivity ratings, only the lowest level per JEDEC standards is shown. Refer to the shipping label for the actual reflow temperature that will be used to mount the part to the printed circuit board.

(6) **Part marking:** There may be an additional marking, which relates to the logo, the lot trace code information, or the environmental category of the part.

Multiple part markings will be inside parentheses. Only one part marking contained in parentheses and separated by a "~" will appear on a part. If a line is indented then it is a continuation of the previous line and the two combined represent the entire part marking for that device.

Important Information and Disclaimer:The information provided on this page represents TI's knowledge and belief as of the date that it is provided. TI bases its knowledge and belief on information provided by third parties, and makes no representation or warranty as to the accuracy of such information. Efforts are underway to better integrate information from third parties. TI has taken and continues to take reasonable steps to provide representative and accurate information but may not have conducted destructive testing or chemical analysis on incoming materials and chemicals. TI and TI suppliers consider certain information to be proprietary, and thus CAS numbers and other limited information may not be available for release.

In no event shall TI's liability arising out of such information exceed the total purchase price of the TI part(s) at issue in this document sold by TI to Customer on an annual basis.

TAPE AND REEL INFORMATION

QUADRANT ASSIGNMENTS FOR PIN 1 ORIENTATION IN TAPE

*All dimensions are nominal

Device	Package Type	Package Drawing	Pins	SPQ	Reel Diameter (mm)	Reel Width W1 (mm)	A0 (mm)	B0 (mm)	K0 (mm)	P1 (mm)	W (mm)	Pin1 Quadrant
DRV8770RGER	VQFN	RGE	24	3000	330.0	12.4	4.25	4.25	1.15	8.0	12.0	Q2

TAPE AND REEL BOX DIMENSIONS

*All dimensions are nominal

Device	Package Type	Package Drawing	Pins	SPQ	Length (mm)	Width (mm)	Height (mm)
DRV8770RGER	VQFN	RGE	24	3000	367.0	367.0	35.0

RGE 24

GENERIC PACKAGE VIEW

VQFN - 1 mm max height

PLASTIC QUAD FLATPACK - NO LEAD

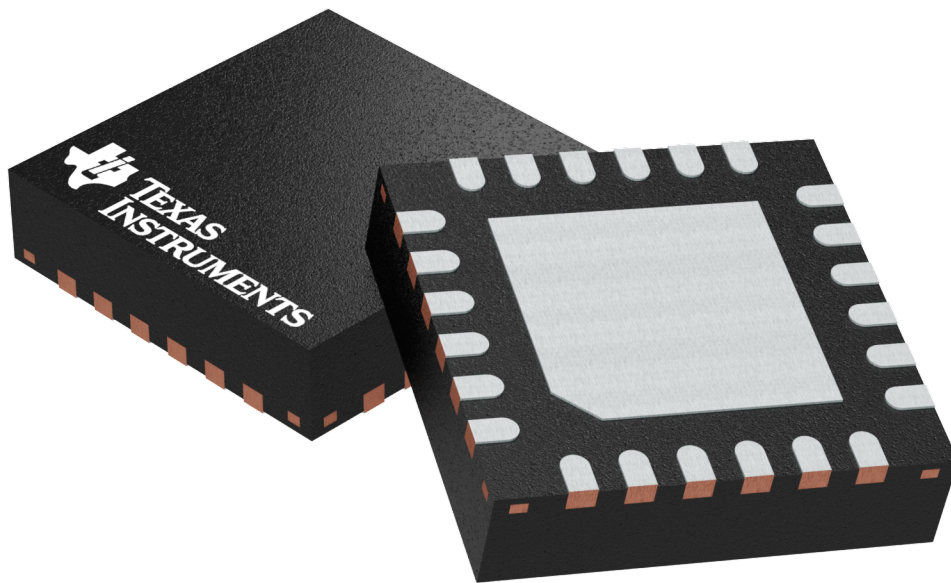

Images above are just a representation of the package family, actual package may vary.
Refer to the product data sheet for package details.

4204104/H

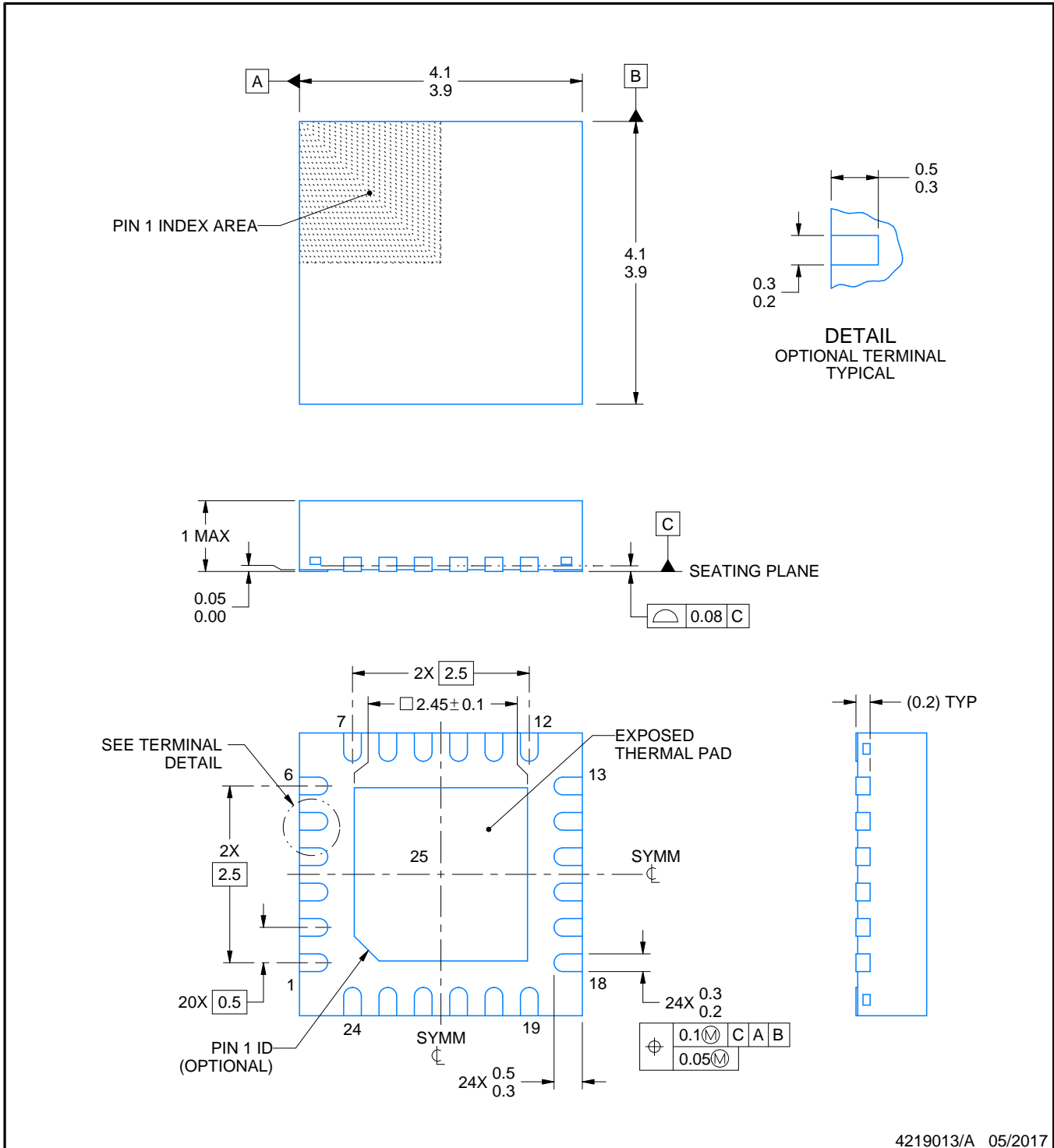
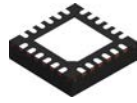

4219013/A 05/2017

NOTES:

1. All linear dimensions are in millimeters. Any dimensions in parenthesis are for reference only. Dimensioning and tolerancing per ASME Y14.5M.
2. This drawing is subject to change without notice.
3. The package thermal pad must be soldered to the printed circuit board for thermal and mechanical performance.

EXAMPLE STENCIL DESIGN

RGE0024B

VQFN - 1 mm max height

PLASTIC QUAD FLATPACK - NO LEAD

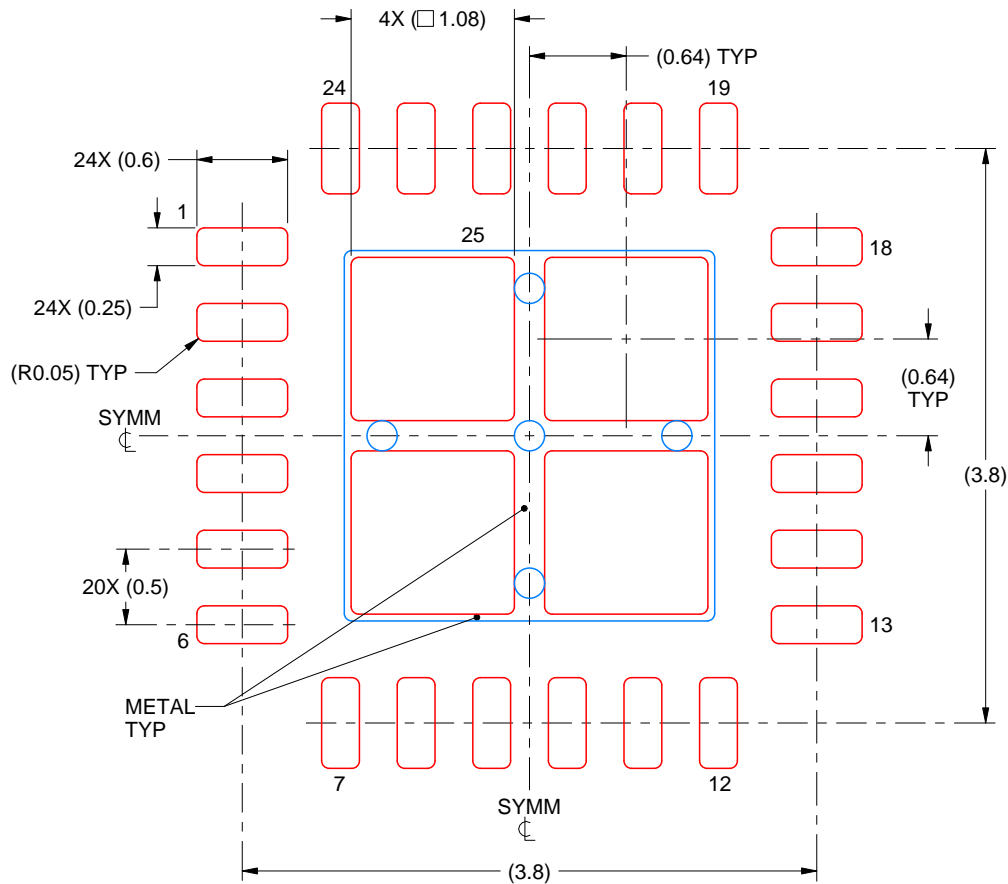

SOLDER PASTE EXAMPLE
BASED ON 0.125 mm THICK STENCIL

EXPOSED PAD 25
78% PRINTED SOLDER COVERAGE BY AREA UNDER PACKAGE
SCALE:20X

4219013/A 05/2017

NOTES: (continued)

6. Laser cutting apertures with trapezoidal walls and rounded corners may offer better paste release. IPC-7525 may have alternate design recommendations.

重要なお知らせと免責事項

TI は、技術データと信頼性データ (データシートを含みます)、設計リソース (リファレンス デザインを含みます)、アプリケーションや設計に関する各種アドバイス、Web ツール、安全性情報、その他のリソースを、欠陥が存在する可能性のある「現状のまま」提供しており、商品性および特定目的に対する適合性の黙示保証、第三者の知的財産権の非侵害保証を含むいかなる保証も、明示的または黙示的にかかわらず拒否します。

これらのリソースは、TI 製品を使用する設計の経験を積んだ開発者への提供を意図したものです。(1) お客様のアプリケーションに適した TI 製品の選定、(2) お客様のアプリケーションの設計、検証、試験、(3) お客様のアプリケーションに該当する各種規格や、その他のあらゆる安全性、セキュリティ、規制、または他の要件への確実な適合に関する責任を、お客様のみが単独で負うものとし、

上記の各種リソースは、予告なく変更される可能性があります。これらのリソースは、リソースで説明されている TI 製品を使用するアプリケーションの開発の目的でのみ、TI はその使用をお客様に許諾します。これらのリソースに関して、他の目的で複製することや掲載することは禁止されています。TI や第三者の知的財産権のライセンスが付与されている訳ではありません。お客様は、これらのリソースを自身で使用した結果発生するあらゆる申し立て、損害、費用、損失、責任について、TI およびその代理人を完全に補償するものとし、TI は一切の責任を拒否します。

TI の製品は、[TI の販売条件](#)、[TI の総合的な品質ガイドライン](#)、[ti.com](#) または TI 製品などに関連して提供される他の適用条件に従い提供されます。TI がこれらのリソースを提供することは、適用される TI の保証または他の保証の放棄の拡大や変更を意味するものではありません。TI がカスタム、またはカスタマー仕様として明示的に指定していない限り、TI の製品は標準的なカタログに掲載される汎用機器です。

お客様がいかなる追加条項または代替条項を提案する場合も、TI はそれらに異議を唱え、拒否します。

Copyright © 2026, Texas Instruments Incorporated

最終更新日 : 2025 年 10 月