

## DS250DF230 25Gbps マルチレート 2 チャンネル・リタイマ

### 1 特長

- 信号コンディショニング内蔵のデュアル・チャンネル・マルチレート・リタイマ
- すべてのチャンネルは独立に 19.6~25.8Gbps でロック (12.16512Gbps、9.8304Gbps、6.144Gbps などのサブレートを含む)
- 非常に低いレイテンシ: 25.78125Gbps のデータ・レートで 500ps 未満 (標準値)
- アダプティブ連続時間リニア・イコライザ (CTLE)
- 連続的なアダプティブ・デンジジョン・フィードバック・イコライザ (DFE) により、温度範囲全体にわたってチャンネル損失の大きな変動を補償可能
- 結合イコライゼーションにより、12.9GHz で 35dB のチャンネル損失をサポート
- オンチップのアイ・モニタ (EOM)、PRBS パターン・チェッカおよびジェネレータ
- 3 タップ FIR フィルタ付きの低ジッタ・トランスミッタ
- 2x2 クロスポイントを内蔵
- システム・クロック同期アプリケーション用に、チャンネル 0 で復元クロックを利用可能
- 単一電源で動作し、低ジッタの基準クロックは不要
- 広い範囲の温度でロック状態を維持

### 2 アプリケーション

- 無線システムおよび有線システムで使用する、フロント・ポート光学インターフェイスのジッタ・クリーニング
- バックプレーン / ミッドプレーンの範囲拡張
- アクティブ・ケーブル・アセンブリ
- 802.3bj 100GbE、InfiniBand EDR、および OIF-CEI-25G-LR/MR/SR/VSR 電気的インターフェイス
- SFP28、QSFP28、CFP2/CFP4、CDFP

### 3 概要

DS250DF230 デバイスは、2 チャンネル、マルチレートのリタイマで、信号コンディショニング機能が内蔵されています。長距離で損失が大きくクロストークを受ける高速なシリアル・リンクの到達距離と堅牢性を拡張し、ビット・エラー・レート (BER) を  $10^{-15}$  以下に抑えるために使用されます。

DS250DF230 の各チャンネルは、19.6Gbps~25.8Gbps の連続した範囲のシリアル・データ・レート、またはサポートされているサブレート (+2 および +4) へ独立にロックできます。これには 12.16512Gbps、9.8304Gbps、6.144Gbps などの主要なデータレートが含まれます。

DS250DF230 は、36 ピン NFBGA および 32 ピン QFN の 2 つのパッケージ・オプションで供給され、5 × 5mm の小型のボディ・サイズを実現します。NFBGA (ZLS) パッケージは、堅牢な性能と設計のしやすさを最小の BOM フットプリントで実現します。また、QFN (RTV) パッケージは、同様の性能特性を備え、ヒートシンクなしで最大 105°C の PCB 温度に対応しています。

#### 製品情報(1)

部品番号	パッケージ	本体サイズ (公称)
DS250DF230ZLS	NFBGA (36)	5.00mm × 5.00mm
DS250DF230RTV	QFN (32)	5.00mm × 5.00mm

- (1) 利用可能なパッケージについては、このデータシートの末尾にある注文情報を参照してください。

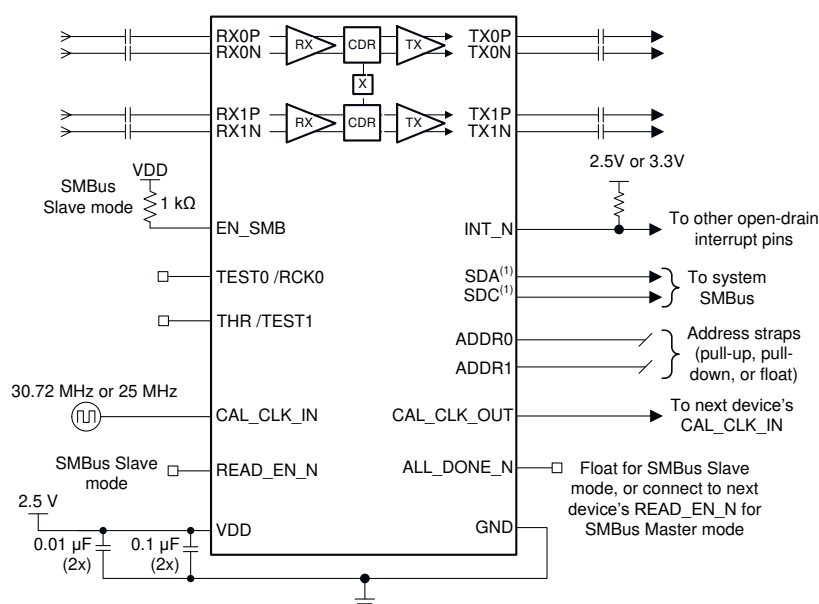

- (1) SMBus signals need to be pulled up elsewhere in the system.

#### 概略回路図



## Table of Contents

1 特長.....	1	8.5 Programming.....	30
2 アプリケーション.....	1	8.6 Register Maps.....	32
3 概要.....	1	<b>9 Application and Implementation.....</b>	<b>92</b>
4 Revision History.....	2	9.1 Application Information.....	92
5 概要 (続き).....	3	9.2 Typical Applications.....	92
6 Pin Configuration and Functions.....	4	<b>10 Power Supply Recommendations.....</b>	<b>105</b>
7 Specifications.....	7	<b>11 Layout.....</b>	<b>106</b>
7.1 Absolute Maximum Ratings.....	7	11.1 Layout Guidelines.....	106
7.2 ESD Ratings.....	7	11.2 Layout Examples.....	106
7.3 Recommended Operating Conditions.....	7	<b>12 Device and Documentation Support.....</b>	<b>108</b>
7.4 Thermal Information.....	8	12.1 Device Support.....	108
7.5 Electrical Characteristics.....	8	12.2 Documentation Support.....	108
7.6 Timing Requirements.....	14	12.3 Receiving Notification of Documentation Updates.....	108
7.7 Switching Characteristics.....	14	12.4 サポート・リソース.....	108
7.8 Typical Characteristics.....	15	12.5 Trademarks.....	108
<b>8 Detailed Description.....</b>	<b>16</b>	<b>13 Electrostatic Discharge Caution.....</b>	<b>108</b>
8.1 Overview.....	16	<b>14 Glossary.....</b>	<b>108</b>
8.2 Functional Block Diagram.....	16	<b>15 Mechanical, Packaging, and Orderable Information.....</b>	<b>108</b>
8.3 Feature Description.....	17		
8.4 Device Functional Modes.....	28		

## 4 Revision History

資料番号末尾の英字は改訂を表しています。その改訂履歴は英語版に準じています。

Changes from Revision B (October 2019) to Revision C (June 2021)	Page
• 文書全体にわたって表、図、相互参照の採番方法を更新.....	1
• QFN (RTV) パッケージ・オプションの情報を追加.....	1
• Added QFN (RTV) pin configuration and functions.....	4
• Added QFN (RTV) thermal information.....	8
• Added $t_{EQ\_Adapt}$ typical value.....	8
• Added footnotes about bit errors during EQ adaptation and difference in $t_{EQ\_ADAPT}$ for lower line rates.....	8
• Added Fast CDR Lock Mode section to Detailed Description.....	19
• Added CDR Status Description to Channel Reg 0x02.....	32

Changes from Revision A (December 2018) to Revision B (October 2019)	Page
• 最初の公開リリース.....	1
• Changed Channel Reg_0x79[4] definition, marking this as RESERVED.....	32
• Changed Channel Reg_0x7E[3:0] definition, marking this as RESERVED.....	32
• Changed Channel Reg_0x7F[5] definition, marking this as RESERVED.....	32
• Changed Channel Reg_0x8C definition, marking this register as RESERVED.....	32
• Added expanded Channel Reg_0x95 definition.....	32

## 5 概要 (続き)

DS250DF230 は単一電源で、必要な外部部品も最小限です。これらの特長により、PCB 配線の複雑性と BOM コストが低減されます。

DS250DF230 の高度なイコライゼーション機能には、低ジッタの 3 タップ送信有限インパルス応答 (FIR) フィルタ、アダプティブ連続時間リニア・イコライザ (CTLE)、アダプティブ・デシジョン・フィードバック・イコライザ (DFE) が含まれています。これにより、複数のコネクタやクロストークが存在する、損失の多い相互接続およびバックプレーンにおいて、到達距離を延長できます。内蔵の CDR 機能は、フロントポート光学モジュール・アプリケーションで、ジッタ・バジェットをリセットし、高速シリアル・データをリタイムするため使用できます。DS250DF230 には 2×2 のクロスポイントが用意されており、ホスト・レーン交差、ファンアウト、多重化のオプションを使用できます。

DS250DF230 は SMBus 経由または外付けの EEPROM により構成可能です。共通チャネル構成を使用して、最大 16 個のデバイスが EEPROM を共有できます。非破壊的なオンチップ・アイ・モニタと PRBS ジェネレータおよびチェッカにより、システム内の診断を行えます。

## 6 Pin Configuration and Functions



图 6-1. ZLS Package 36-Pin NFBGA Top View



图 6-2. RTV Package 32-Pin QFN Top View

表 6-1. Pin Functions

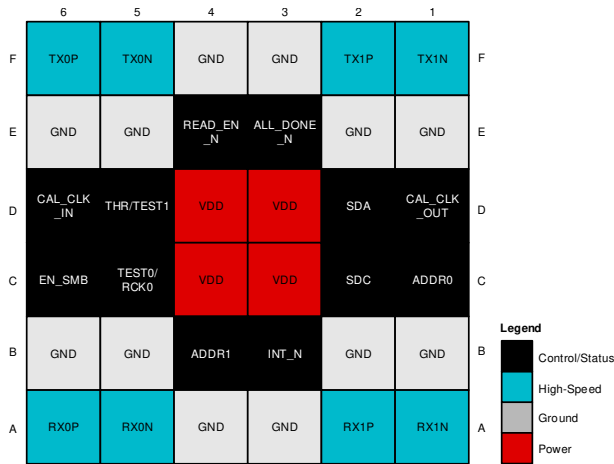
NAME	PIN		TYPE	INTERNAL PULL-UP/ PULL-DOWN	DESCRIPTION
	NFBGA	QFN			
HIGH-SPEED DIFFERENTIAL I/Os					
RX0P	A6	18	Input	None	Inverting and noninverting differential inputs to the equalizer. An on-chip, 100-Ω termination resistor connects RXP to RXN. These inputs must be AC-coupled.
RX0N	A5	19	Input	None	
RX1P	A2	22	Input	None	Inverting and noninverting differential inputs to the equalizer. An on-chip, 100-Ω termination resistor connects RXP to RXN. These inputs must be AC-coupled.
RX1N	A1	23	Input	None	
TX0P	F6	7	Output	None	Inverting and noninverting 50Ω driver outputs. These outputs must be AC-coupled.
TX0N	F5	6	Output	None	
TX1P	F2	3	Output	None	Inverting and noninverting 50Ω driver outputs. These outputs must be AC-coupled.
TX1N	F1	2	Output	None	
CALIBRATION CLOCK PINS					
CAL_CLK_IN	D6	10	Input, 2.5V LVC MOS	None	30.72-MHz (±100 PPM), 2.5-V single-ended clock from external oscillator. No stringent phase noise or jitter requirements on this clock. Also supports 25-MHz (±100 PPM) clock by programming the corresponding registers.
CAL_CLK_OUT	D1	31	Output, 2.5V LVC MOS	None	2.5-V buffered replica of calibration clock input (CAL_CLK_IN) for connecting multiple (up to 20 or more) devices in a daisy-chained fashion.
SYSTEM MANAGEMENT BUS (SMBus) PINS					
ADDR0	C1	25	Input, 4-level	None	4-level strap pins used to set the SMBus address of the device. The pin state is read on power-up. The multi-level nature of these pins allows for 16 unique device addresses. The four strap options include: 0: 1 kΩ to GND R: 10 kΩ to GND F: Float 1: 1 kΩ to VDD Refer to <a href="#">セクション 8.4.3</a> for more information.
ADDR1	B4	16	Input, 4-level	None	

**表 6-1. Pin Functions (continued)**

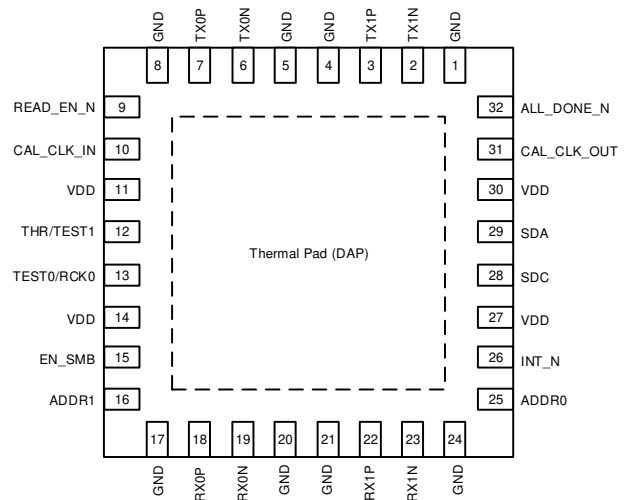
NAME	PIN		TYPE	INTERNAL PULL-UP/ PULL-DOWN	DESCRIPTION
	NFBGA	QFN			
EN_SMB	C6	15	Input, 4-level	None	Four-level, 2.5-V input used to select between SMBus master mode (float) and SMBus slave mode (high). The three defined levels are: R: 10 kΩ to GND - RESERVED, TI test mode F: Float - SMBus Master Mode (2.5-V/3.3-V SMBUS interface only) 1: 1 kΩ to VDD - SMBus Slave Mode
THR /TEST1	D5	12	Input, 4-level	None	Select the electrical voltage of SMBus interface. 2.5-V/3.3-V or 1.8-V: 1: 1 kΩ to VDD - 1.8-V SMBus interface F: Float - 1.8-V SMBus interface 0: 1 kΩ to GND - 2.5-V/3.3-V SMBus interface In TI test mode (EN_SMB = 10k Ohm to GND), this is reserved TI test pin.
SDA	D2	29	I/O, Open Drain	None	SMBus data input / open-drain output. External 2-kΩ to 5-kΩ pullup resistor is required as per SMBus interface standard. This pin is 3.3-V tolerant.
SDC	C2	28	I/O, Open Drain	None	SMBus clock input / open-drain clock output. External 2-kΩ to 5-kΩ pullup resistor is required as per SMBus interface standard. This pin is 3.3-V tolerant.
<b>SMBus MASTER MODE PINS</b>					
ALL_DONE_N	E3	32	Output, 2.5-V LVCMOS	None	Indicates the completion of a valid EEPROM register load operation when in SMBus Master Mode (EN_SMB=Float): High = External EEPROM load failed or incomplete Low = External EEPROM load successful and complete When in SMBus slave mode (EN_SMB=1), this output reflects the status of the READ_EN_N input.
READ_EN_N	E4	9	Input, 3.3-V LVCMOS	Weak pullup to VDD	SMBus Master Mode (EN_SMB=Float): When asserted low, initiates the SMBus master mode EEPROM read function. Once EEPROM read is complete (indicated by assertion of ALL_DONE_N low), this pin can be held low for normal device operation. SMBus Slave Mode (EN_SMB=1): When asserted low, this causes the device to be held in reset (SMBus state machine reset and register reset). This pin must be pulled high or left floating for normal operation in SMBus Slave Mode. This pin is 3.3-V tolerant.
<b>MISCELLANEOUS PINS</b>					
INT_N	B3	26	Output, Open-Drain	None	Open-drain, 3.3-V tolerant active-low interrupt output. It pulls low when an interrupt occurs. The events which trigger an interrupt are programmable through SMBus registers. This pin can be connected in a wired-OR fashion with other device's interrupt pin. A single pullup resistor in the 2-kΩ to 5-kΩ range is adequate for the entire INT_N net.
TEST0 /RCK0	C5	13	I/O, 2.5-V LVCMOS	None	In TI test mode (EN_SMB = 10k Ohm to GND), this is reserved TI test pin. During normal (non-test-mode) operation, this pin is configured as input by default and therefore is not affected by the presence of a signal. This pin may be left floating, tied to GND, or connected to a 2.5-V (max) output. This pin can be configured to offer the recovered clock for CH0 by programming the corresponding registers. The signal is 2.5-V LVCMOS.
<b>POWER</b>					
VDD	C3, C4, D3, D4	11, 14, 27, 30	Power	None	Power supply, VDD = 2.5 V ±5%. TI recommends connecting at least four de-coupling capacitors between the Retimer VDD plane and GND as close to the Retimer as possible. For example, two 0.1-μF capacitors, and two 0.01-μF capacitors directly beneath the device or as close to the VDD pins as possible. The VDD pins on this device must be connected through a low-resistance path to the board VDD plane.

表 6-1. Pin Functions (continued)

NAME	PIN		TYPE	INTERNAL PULL-UP/ PULL- DOWN	DESCRIPTION
	NFBGA	QFN			
GND	A3, A4,B1, B2,B5, B6,E1, E2,E5, E6,F3, F4	1, 4, 5, 8, 17, 20, 21, 24	Power	None	Ground reference. The GND pins on this device must be connected through a low-resistance path to the board GND plane.
DAP	—	DAP	Power	None	DAP is the exposed pad at the bottom of the RTV package. The exposed pad should be connected to the GND plane through a 3x3 via array.

## 7 Specifications

### 7.1 Absolute Maximum Ratings

over operating free-air temperature range (unless otherwise noted)<sup>(1)</sup>

		MIN	MAX	UNIT
VDD_ABSMAX	Supply Voltage, VDD to GND	-0.5	2.75	V
VI <sub>O2.5V</sub> -ABSMAX	2.5V I/O voltage (LVCMOS and Analog)	-0.5	2.75	V
VI <sub>O3.3V</sub> -ABSMAX	3.3V I/O Voltage (SDA, SDC, INT_N, READ_EN)	-0.5	4	V
VIN_ABSMAX	Signal Input voltage(RXnP, RXnN)	-0.5	2.75	V
VOU <sub>T</sub> _ABSMAX	Signal Output voltage(TXnP, TXnN)	-0.5	2.75	V
T <sub>J</sub> _ABSMAX	Junction Temperature		150	°C
T <sub>stg</sub>	Storage Temperature range	-40	150	°C

- (1) Stresses beyond those listed under *Absolute Maximum Rating* may cause permanent damage to the device. These are stress ratings only, which do not imply functional operation of the device at these or any other conditions beyond those indicated under *Recommended Operating Condition*. Exposure to absolute-maximum-rated conditions for extended periods may affect device reliability.

### 7.2 ESD Ratings

			VALUE	UNIT
V <sub>(ESD)</sub>	Electrostatic discharge	Human body model (HBM), per ANSI/ESDA/JEDEC JS-001, all pins <sup>(1)</sup>	±2000	V
		Charged device model (CDM), per JEDEC specification JESD22-C101, all pins <sup>(2)</sup>	±1000	

- (1) JEDEC document JEP155 states that 500-V HBM allows safe manufacturing with a standard ESD control process.  
(2) JEDEC document JEP157 states that 250-V CDM allows safe manufacturing with a standard ESD control process.

### 7.3 Recommended Operating Conditions

over operating free-air temperature range (unless otherwise noted)

		MIN	NOM	MAX	UNIT
VDD	Supply voltage, VDD to GND. DC plus AC power should not exceed these limits.	2.375	2.5	2.625	V
N <sub>VDD</sub>	Supply noise, DC to <50 Hz, sinusoidal <sup>(1)</sup>			250	mVpp
N <sub>VDD</sub>	Supply noise, 50 Hz to 10 MHz, sinusoidal <sup>(1)</sup>			20	mVpp
N <sub>VDD</sub>	Supply noise, >10 MHz, sinusoidal <sup>(1)</sup>			10	mVpp
T <sub>ramp</sub>	VDD supply ramp time, from 0 V to 2.375 V	150			us
T <sub>J</sub>	Operating junction temperature	-40		110	°C
T <sub>A</sub>	Operating ambient temperature	-40		85 <sup>(2)</sup>	°C
VI <sub>O2.5V</sub>	2.5 V LVCMOS	2.375	2.5	2.625	V
VI <sub>O3.3V,INT_N</sub>	Open Drain I/O voltage(INT_N)			3.6	V
VI <sub>O3.3V</sub>	Open Drain I/O voltage(SDA,SDC) <sup>(3)</sup>			3.6	V

- (1) Steps must be taken to ensure the combined AC plus DC noise meets the VDD supply voltage limits.  
(2) Steps must be taken to ensure the operating junction temperature range and stay-in-lock range (TEMP<sub>LOCK+</sub>, TEMP<sub>LOCK-</sub>) are met. Refer to the [Electrical Characteristics](#) for more details concerning TEMP<sub>LOCK+</sub> and TEMP<sub>LOCK-</sub>.  
(3) Set THR pin to select SMBUS electrical voltage

## 7.4 Thermal Information

THERMAL METRIC <sup>(1)</sup>		CONDITIONS <sup>(2)</sup>	DS250DF230ZLS	DS250DF230RTV	UNIT
			ZLS (NFBGA)	RTV (QFN)	
			36 PINS	32 PINS	
$R_{\theta JA}$	Junction-to-ambient thermal resistance	4-layer JEDEC board	49.3	30.3	°C/W
$R_{\theta JC(top)}$	Junction-to-case (top) thermal resistance	4-layer JEDEC board	20.7	17.6	°C/W
$R_{\theta JB}$	Junction-to-board thermal resistance	4-layer JEDEC board	24.5	10.7	°C/W
$\Psi_{JT}$	Junction-to-top characterization parameter	4-layer JEDEC board	0.5	0.2	°C/W
$\Psi_{JB}$	Junction-to-board characterization parameter	4-layer JEDEC board	24.7	10.6	°C/W
$R_{\theta JC(bot)}$	Junction-to-case (bot) thermal resistance	4-layer JEDEC board	--	1.8	°C/W

- (1) For more information about traditional and new thermal metrics, see the [Semiconductor and IC Package Thermal Metrics](#) application report.
- (2) No heat sink or airflow was assumed for these estimations. Depending on the application, a heat sink, faster airflow, and/or reduced ambient temperature (<85 C) may be required in order to meet the maximum junction temperature specification per the Recommended Operating Conditions.

## 7.5 Electrical Characteristics

over operating free-air temperature range (unless otherwise noted)

PARAMETER		TEST CONDITIONS	MIN	TYP	MAX	UNIT
<b>POWER CONSUMPTION</b>						
$W_{Channel}$	Power Consumption Per Active Channel	Active mode with CTLE, Tx FIR, full DFE and Crosspoint enabled. Idle power consumption not included.		256	347	mW
		Active mode with CTLE, Tx FIR, and full DFE enabled. Crosspoint disabled. Idle power consumption not included.		248		mW
		Active mode with CTLE, Tx FIR, and partial DFE enabled(taps 1-2 only). Crosspoint and DFE taps 3-5 disabled. Idle power consumption not included.		235		mW
		Active mode with CTLE, and Tx FIR enabled. DFE and crosspoint disabled. Idle power consumption not included.		226		mW
		Assuming CDR acquiring lock with CTLE, full DFE, Tx FIR, Driver, and Crosspoint enabled. Idle power consumption not included.		380	445	mW
		Assuming CDR acquiring lock with CTLE, full DFE, Tx FIR, Driver, and Crosspoint disabled. Idle power consumption not included.		333		mW
$W_{PRBS}$	PRBS Checker Power Consumption only Per Channel			200		mW
	PRBS Generator Power Consumption only Per Channel			190		mW
$W_{Static\_Total}$	Total Idle Power Consumption	Idle/Static mode. Power supplied, no high-speed data present at inputs, channel automatically powered down.		165		mW
$I_{Static\_Total}$	Idle mode total device supply current consumption	Idle/Static mode. Power supplied, no high-speed data present at inputs, channel automatically powered down.		66	100	mA

## 7.5 Electrical Characteristics (continued)

over operating free-air temperature range (unless otherwise noted)

PARAMETER		TEST CONDITIONS	MIN	TYP	MAX	UNIT
I <sub>Total</sub>	Active Mode Total Device Supply Current Consumption	Active mode with CTLE, Tx FIR, full DFE and Crosspoint enabled.		271	361	mA
		Active mode with CTLE, Tx FIR, and full DFE enabled. Crosspoint disabled.		265		mA
		Active mode with CTLE, Tx FIR, and partial DFE enabled (taps 1-2 only). Crosspoint and DFE taps 3-5 disabled.		255		mA
		Active mode with CTLE, and Tx FIR enabled. DFE and crosspoint disabled.		247		mA
<b>GENERAL DEVICE-LEVEL SPECIFICATIONS</b>						
R <sub>baud</sub>	Supported input data rate	Full-rate (divide-by-1) mode of operation.	19.6		25.8	Gbps
		Half-rate (divide-by-2) mode of operation.	9.8		12.9	Gbps
		Quarter-rate (divide-by-4) mode of operation.	4.9		6.45	Gbps
t <sub>EEPROM</sub>	EEPROM configuration load time	Single device reading its configuration from an EEPROM. Common channel configuration. This time scales with the number of devices reading from the same EEPROM.			15 <sup>(1)</sup>	ms
	EEPROM configuration load time	Single device reading its configuration from an EEPROM. Unique-channel configuration. This time scales with the number of devices reading from the same EEPROM.			40 <sup>(1)</sup>	ms
t <sub>POR</sub>	Power-on reset assertion-time	Internal power-on reset (PoR) stretch between stable power supply and de-assertion of internal PoR. The SMBus address is latched on the completion of the PoR stretch, and SMBus accesses are permitted.			50	ms
<b>HIGH-SPEED DIFFERENTIAL OUTPUTS (TXnP, TXnN)</b>						
V <sub>OD</sub>	Output differential voltage amplitude	Measured with c(0)=4 setting (REG_0x3D[6:0]=0x04, REG_0x3E[6:0]=0x40, REG_0x3F[6:0]=0x40). Differential measurement using an 8T pattern (eight 1s followed by eight 0s) at 25.78125 Gbps with TXPn and TXNn terminated by 50 Ohms to GND.		392		mVppd
	Output differential voltage amplitude	Measured with c(0)=31 setting (REG_0x3D[6:0]=0x1F, REG_0x3E[6:0]=0x40, REG_0x3F[6:0]=0x40). Differential measurement using an 8T pattern (eight 1s followed by eight 0s) at 25.78125 Gbps with TXPn and TXNn terminated by 50 Ohms to GND.		1195		mVppd
V <sub>OD_Raw_L</sub>	Output differential voltage amplitude under Raw Mode, low swing setting	Raw Mode(CDR Bypassed), low swing setting(REG_0xD[0]=0), differential measurement using 8T pattern(eight 1s followed by eight 0s) at 25.78125Gbps and 9.8304Gbps with TXPn and TXNn terminated by 50 Ohms to GND. RPH=REG_0x1A[7:6]=0		602		mVppd

## 7.5 Electrical Characteristics (continued)

over operating free-air temperature range (unless otherwise noted)

PARAMETER		TEST CONDITIONS	MIN	TYP	MAX	UNIT
$V_{OD\_Raw\_H}$	Output differential voltage amplitude under Raw Mode, high swing setting	Raw Mode(CDR Bypassed), high swing setting(REG_0xD[0]=1), differential measurement using 8T pattern(eight 1s followed by eight 0s) at 25.78125Gbps and 9.8304Gbps with TXPn and TXNn terminated by 50 Ohms to GND. RPH=REG_0x1A[7:6]=0x3		919		mVppd
$V_{OD\_Idle}$	Differential output amplitude with TX disabled			6.1		mVppd
$V_{cm\_TX}$	DC common-mode output voltage	With respect to signal ground. Measured using an 8T pattern (eight 1s followed by eight 0s) at 25.78125 Gbps with TXPn and TXNn terminated by 50 Ohms to GND. Measured for c(-1)=c(1)=0 and VOD settings in the range of 600 mVppd to 1200 mVppd.		1.01		V
$V_{cm\_TX\_AC}$	Common-mode AC output noise	With respect to signal ground. Measured with PRBS9 data pattern. Measured with a 33GHz (-3dB) low-pass filter.		7.4		mV, RMS
$t_r, t_f$	Output transition-time	20%-to-80% rise time and 80%-to-20% fall time on a clock-like {11111 00000} data pattern at 25.78125 Gbps. Measured for ~750 mVppd output amplitude and no equalization: REG_0x3D=+13, REG_0x3E=0, REG_0x3F=0		17.5		ps
	Output transition-time, Low slew rate setting	Slow slew rate setting(REG_0x3D[5]=1), 20%-to-80% rise time and 80%-to-20% fall time on a clock-like {11111 00000} data pattern at 9.8304 Gbps. Measured for ~750 mVppd output amplitude and no equalization: REG_0x3D=+13, REG_0x3E=0, REG_0x3F=0		24		ps
$RL_{SDD22}$	Differential output return loss, SDD22 <sup>(2)</sup>	Between 50 MHz and 5 GHz		-15.9		dB
	Differential output return loss, SDD22 <sup>(2)</sup>	Between 5 GHz and 12.9 GHz		-13		dB
$RL_{SCD22}$	Differential to common-mode output return loss, SCD22 <sup>(2)</sup>	Between 50 MHz and 12.9 GHz		-24		dB
$RL_{SDC22}$	Common-mode to differential output return loss, SDC22 <sup>(2)</sup>	Between 50 MHz and 12.9 GHz		-24		dB
$RL_{SCC22}$	Common-mode output return loss, SCC22 <sup>(2)</sup>	Between 50 MHz and 10 GHz		-8		dB
	Common-mode output return loss, SCC22 <sup>(2)</sup>	Between 10 GHz and 12.9 GHz		-8.5		dB
<b>RETIMER TIMING SPECIFICATIONS</b>						
$t_D$	Input-to-output latency (propagation delay) through a channel	No Crosspoint; CDR enabled and locked.		4.5 UI + 175 ps		ps
		Crosspoint enabled; CDR enabled and locked.		4.5 UI + 220 ps		ps
		No crosspoint; CDR in raw mode.		140		ps
$t_{D\_V}$	Variation of Input-to-output latency	Crosspoint enabled; CDR enabled and locked.		± 50		ps
$t_{SK}$	Channel-to-channel interpair skew	Latency difference between channels at full-rate.		30		ps

## 7.5 Electrical Characteristics (continued)

over operating free-air temperature range (unless otherwise noted)

PARAMETER		TEST CONDITIONS	MIN	TYP	MAX	UNIT
t <sub>Lock</sub>	CDR lock acquisition-time, Normal Lock Mode	Measured at 25.78125 Gbps, Adapt mode 2 (REG_0x31[6:5]=0x2)		<100		ms
	CDR lock acquisition-time, Fast Lock Mode	Measured at 25.78125 Gbps, Adapt mode 2 (REG_0x31[6:5]=0x2). Fast Lock Mode Enabled (REG_0xAC[7] = 1). Adaptation process still runs to find the best CTLE/DFE values after CDR lock is declared.		<10		ms
	CDR lock acquisition-time, Fast Lock Mode	Measured at 25.78125 Gbps, Adapt mode 0 (Reg_0x31[6:5]=0x0), Fast Lock Mode Enabled (REG_0xAC[7] = 1). Adaptation process still runs to find the best CTLE/DFE values after CDR lock is declared.		<2		ms
t <sub>EQ_Adapt</sub>	Total EQ Adaptation Completion Time (includes t <sub>LOCK</sub> )	Measured at 25.78125 Gbps, Adapt mode 2 (REG_0x31[6:5]=0x2) <sup>(3)</sup> <sup>(4)</sup>		<3		s
<b>RETIMER JITTER SPECIFICATIONS</b>						
J <sub>TJ</sub>	Output Total jitter (TJ)	Measured at 25.78125 Gbps to a probability level of 1E-12 with PRBS11 data pattern an evaluation board traces de-embedded		0.16		U <sub>Ipp</sub> @ 1E-12
J <sub>RJ</sub>	Output Random Jitter (RJ)	Measured at 25.78125 Gbps to a probability level of 1E-12 with PRBS11 data pattern an evaluation board traces de-embedded		6.8		mUI RMS
J <sub>DCCD</sub>	Output Duty Cycle Distortion (DCD)	Measured at 25.78125 Gbps to a probability level of 1E-12 with PRBS11 data pattern an evaluation board traces de-embedded		3.7		mU <sub>Ipp</sub>
<b>HIGH-SPEED DIFFERENTIAL INPUTS (RXnP, RXnN)</b>						
V <sub>IDMax</sub>	Maximum tolerable input differential voltage	For normal operation		1200		mV <sub>ppd</sub>
V <sub>cm-Self</sub>	Self-generated input common mode			1.79		V
RL <sub>SDD11</sub>	Differential input return loss, SDD11 <sup>(5)</sup>	Between 50 MHz and 3.69 GHz		-20		dB
	Differential input return loss, SDD11 <sup>(5)</sup>	Between 3.69 GHz and 12.9 GHz		-13		dB
RL <sub>SDC11</sub>	Common-mode to differential input return loss, SDC11 <sup>(5)</sup>	Between 50 MHz and 12.9 GHz		-23		dB
RL <sub>SCD11</sub>	Differential to common-mode input return loss, SCD11 <sup>(5)</sup>	Between 50 MHz and 12.9 GHz		-23		dB
RL <sub>SCC11</sub>	Common-mode input return loss, SCC11 <sup>(5)</sup>	Between 150 MHz and 10 GHz		-11		dB
	Common-mode input return loss, SCC11 <sup>(5)</sup>	Between 10 GHz and 12.9 GHz		-8		dB
V <sub>SDAT</sub>	AC signal detect assert (ON) threshold level	Minimum input peak-to-peak amplitude level at device pins required to assert signal detect. Assumes default assert threshold setting. Measured at 25.78125 Gbps with PRBS7.		145		mV <sub>ppd</sub>
V <sub>SDDT</sub>	AC signal detect de-assert (OFF) threshold level	Maximum input peak-to-peak amplitude level at device pins which causes signal detect to de-assert. Assumes default de-assert threshold setting. Measured at 25.78125 Gbps with PRBS7.		84		mV <sub>ppd</sub>

## 7.5 Electrical Characteristics (continued)

over operating free-air temperature range (unless otherwise noted)

PARAMETER		TEST CONDITIONS	MIN	TYP	MAX	UNIT
<b>RETIMER CLOCK AND DATA RECOVERY SPECIFICATIONS</b>						
BW <sub>PLL</sub>	PLL bandwidth	Measured at 9.8304 Gbps with PRBS7 data pattern		4		MHz
	PLL bandwidth	Measured at 25.78125 Gbps with PRBS7 data pattern		4.7		MHz
J <sub>PEAK</sub>	Jitter peaking	Measured at 9.8304 Gbps with PRBS7 data pattern.		0.5		dB
	Jitter peaking	Measured at 25.78125 Gbps with PRBS7 data pattern.		0.5		dB
J <sub>TOL</sub>	Input jitter tolerance	Measured at 25.78125 Gbps with SJ frequency = 190 KHz, 30dB input channel loss, PRBS31 data pattern, ~800 mVppd launch amplitude, and 0.18 UIpp total uncorrelated output jitter in addition to the applied SJ. BER < 1E-12.		9		UIpp
	Input jitter tolerance	Measured at 25.78125 Gbps with SJ frequency = 940 KHz, 30dB input channel loss, PRBS31 data pattern, ~800 mVppd launch amplitude, and 0.18 UIpp total uncorrelated output jitter in addition to the applied SJ. BER < 1E-12.		1		UIpp
	Input jitter tolerance	Measured at 25.78125 Gbps with SJ frequency > 15MHz, 30dB input channel loss, PRBS31 data pattern, ~800 mVppd launch amplitude, and 0.18 UIpp total uncorrelated output jitter in addition to the applied SJ. BER < 1E-12.		0.33		UIpp
TEMP <sub>LOCK-</sub>	CDR stay-in-lock junction temperature range, negative ramp. Maximum junction temperature change below initial CDR lock acquisition temperature	110 °C junction temperature starting, ramp rate -3°C/minute, 12 layer PCB		150		°C
TEMP <sub>LOCK+</sub>	CDR stay-in-lock junction temperature range, positive ramp. Maximum junction temperature change above initial CDR lock acquisition temperature	-40 °C junction temperature starting, ramp rate +3°C/minute, 12 layer PCB		150		°C
<b>RECOVERED CLOCK SPECIFICATIONS</b>						
RCK <sub>f</sub>	Recovered Clock frequency on RCK0 pin	Measured with input data rate as 24.33024 Gbps or 12.16512 Gbps or 10.1376 Gbps 9.8304 Gbps or 6.144 Gbps or 4.9152 Gbps		30.72		MHz
	Recovered Clock frequency on RCK0 pin	Measured with input data rate as 25.78125Gbps or 10.3125Gbps		32.2265625		MHz
RCK <sub>Phase</sub>	RCK <sub>f</sub> Phase Noise Performance <sup>(6)</sup>	<= 100 Hz		< -59		dBc/Hz
		Between 100 Hz and 1 kHz		< -84		dBc/Hz
		Between 1 kHz and 10 kHz		< -103		dBc/Hz
		> 10 kHz		< -122		dBc/Hz
<b>CALIBRATION CLOCK SPECIFICATIONS</b>						
CLK <sub>f</sub>	Calibration clock frequency	Option 1: 30.72 MHz		30.72		MHz
	Calibration clock frequency	Option 2: 25 MHz		25		MHz
CLK <sub>ppm</sub>	Calibration clock PPM tolerance		-100		100	PPM
CLK <sub>IDC</sub>	Calibration clock input duty cycle		40	50	60	Percent

## 7.5 Electrical Characteristics (continued)

over operating free-air temperature range (unless otherwise noted)

PARAMETER		TEST CONDITIONS	MIN	TYP	MAX	UNIT
CLK <sub>ODC</sub>	Intrinsic calibration clock duty cycle distortion	Intrinsic duty cycle distortion of chip calibration clock output at the CAL_CLK_OUT pin, assuming 50% duty cycle on CAL_CLK_IN pin.	45	50	55	Percent
CLK <sub>num</sub>	Number of devices which can be cascaded from CAL_CLK_OUT to CAL_CLK_IN	Assumes worst-case 60%/40% input duty cycle on the first device. CAL_CLK_OUT from first device connects to CAL_CLK_IN of second device, and so on until the last device.		20		N/A
<b>LVC MOS DC SPECIFICATIONS</b>						
V <sub>IH</sub>	Input high-level voltage	2.5 V LVC MOS pins	1.75		VDD	V
		3.3 V LVC MOS pin (READ_EN_N)	1.75		3.6	V
V <sub>IL</sub>	Input low-level voltage	2.5 V LVC MOS pins	GND		0.7	V
		3.3 V LVC MOS pin (READ_EN_N)	GND		0.8	V
V <sub>th</sub>	High-level(1) input voltage	4-level pins ADDR0, ADDR1, EN_SMB and THR	0.98 x VDD			V
	Float level input voltage	4-level pins ADDR0, ADDR1, EN_SMB and THR	0.69 x VDD			V
	10K to GND input voltage	4-level pins ADDR0, ADDR1, EN_SMB and THR	0.25 x VDD			V
	Low-level (0) input voltage	4-level pins ADDR0, ADDR1, EN_SMB and THR		0.1		V
V <sub>OH</sub>	High-level output voltage	IOH = 4mA	2			V
V <sub>OL</sub>	Low-level output voltage	IOL = -4mA			0.4	V
I <sub>IH</sub>	Input high leakage current	Vinput = VDD, Open drain pins			70	uA
	Input high leakage current	Vinput = VDD and CAL_CLK_IN pins			65	uA
	Input high leakage current	Vinput = VDD, ADDR[1:0] and EN_SMB pins			65	uA
	Input high leakage current	Vinput = VDD, READ_EN_N			15	uA
I <sub>IL</sub>	Input low leakage current	Vinput = 0V, Open drain pins	-15			uA
	Input low leakage current	Vinput = 0V, CAL_CLK_IN pins	-15			uA
	Input low leakage current	Vinput = 0V, ADDR[1:0], READ_EN_N, and EN_SMB pins	-115			uA

- (1) From low assertion of READ\_EN\_N to low assertion of ALL\_DONE\_N. Does not include Power-On Reset time
- (2) Measured with an evaluation board which uses microstrip traces and low-loss dielectric with approximately 4 dB insertion loss at 12.9 GHz between DS250DF230 and the measurement instrument.
- (3) Prior to EQ adaptation completion, retimer output may not be error-free.
- (4) There may be an observed increase from the typical  $t_{EQ\_Adapt}$  time for lower line rates (e.g. 10.3125 Gbps).
- (5) Measured with an evaluation board which uses microstrip traces and low-loss dielectric with approximately 4 dB insertion loss at 12.9 GHz between DS250DF230 and the measurement instrument.
- (6) Measured with input data from DS280DF810 evaluation board, at 24.33024 Gbps or 10.1376 Gbps or 25.78125Gbps or 10.3125 Gbps.

## 7.6 Timing Requirements

PARAMETER		TEST CONDITIONS	MIN	NOM	MAX	UNIT
<b>SMBus ELECTRICAL CHARACTERISTICS (SLAVE MODE)</b>						
V <sub>IH</sub>	Input high-level voltage 1.8 V SMBUS Interface	SDA and SDC	1.35		3.6	V
V <sub>IH</sub>	Input high-level voltage 2.5 V/3.3 V SMBUS Interface	SDA and SDC	1.75		3.6	V
V <sub>IL</sub>	Input low-level voltage	SDA and SDC	GND		0.8	V
C <sub>IN</sub>	Input pin capacitance			2		pF
V <sub>OL</sub>	Low-level output voltage	SDA or SDC or INT, IOL = 1.25 mA			0.4	V
I <sub>IN</sub>	Input current	SDA or SDC, VINUT = VIN, VDD, GND	-15		15	uA
T <sub>R</sub>	SDA rise time, read operation	Pull up resistor = 1 kΩ, Cb = 50pF		150		ns
T <sub>F</sub>	SDA fall time, read operation	Pull up resistor = 1 kΩ, Cb = 50pF		4.5		ns
<b>RECOMMENDED SMBus SWITCHING CHARACTERISTICS (SLAVE MODE)</b>						
f <sub>SDC</sub>	SDC clock frequency		10	100	400	kHz
t <sub>HD_DAT</sub>	Data hold time			0.75		ns
t <sub>SU_DAT</sub>	Data setup time			100		ns

## 7.7 Switching Characteristics

PARAMETER		TEST CONDITIONS	MIN	NOM	MAX	UNIT
<b>SMBus SWITCHING CHARACTERISTICS (2.5 V and 3.3 V MASTER MODE)</b>						
f <sub>SDC</sub>	SDC clock frequency		260	303	346	kHz
T <sub>LOW</sub>	SDC low period			1.90		μs
T <sub>HIGH</sub>	SDC high period			1.40		μs
T <sub>HD_STA</sub>	Hold time start operation			1.3		μs
T <sub>SU_STA</sub>	Setup time start operation			1.3		μs
T <sub>HD_DAT</sub>	Data hold time			0.5		μs
T <sub>SD-DAT</sub>	Data setup time			1.3		μs
T <sub>SU_STO</sub>	Stop condition setup time			1.4		μs
T <sub>BUF</sub>	Bus free time between Stop-Start			1.8		μs
T <sub>R</sub>	SDC rise time	Pull up resistor = 1 kΩ		70		ns
T <sub>F</sub>	SDC fall time	Pull up resistor = 1 kΩ		8		ns

## 7.8 Typical Characteristics

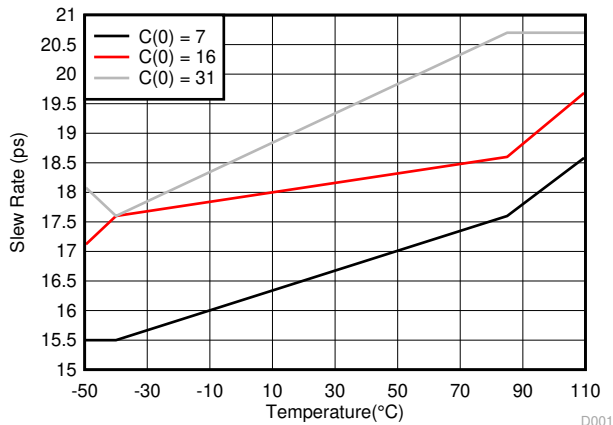

7-1. Output Transition-time vs Ambient Temperature

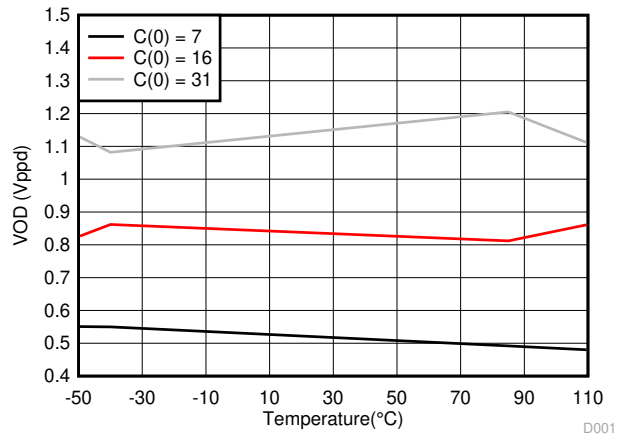

7-2. Typical VOD vs Ambient Temperature

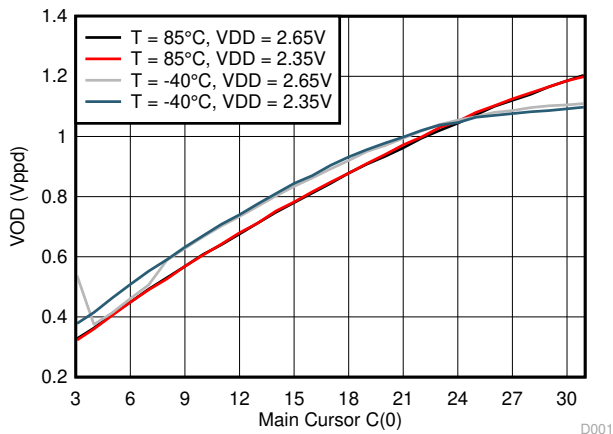

7-3. Typical VOD vs FIR Main-Cursor

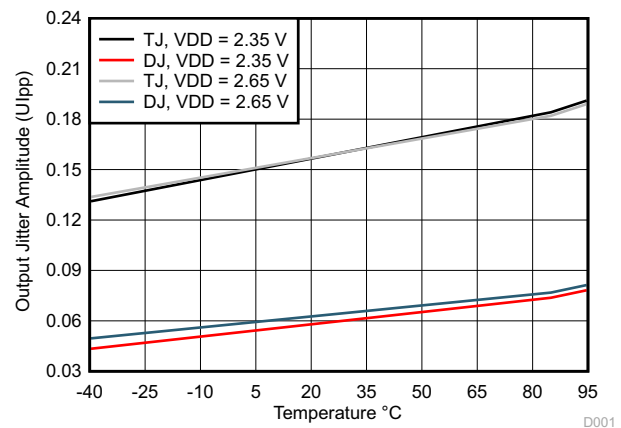

7-4. Typical Output Jitter vs Ambient Temperature at 25.78125 Gbps

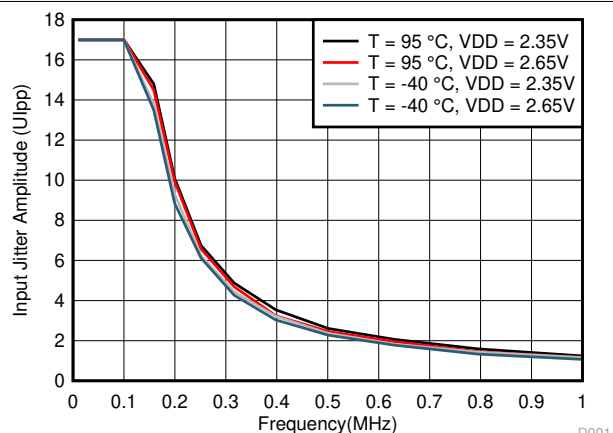

0.1 MHz to 1 MHz Input Random Jitter = 0.078 Ujpp

7-5. Typical Sinusoidal Input Jitter Tolerance for 30-dB Channel at 25.78125 Gbps

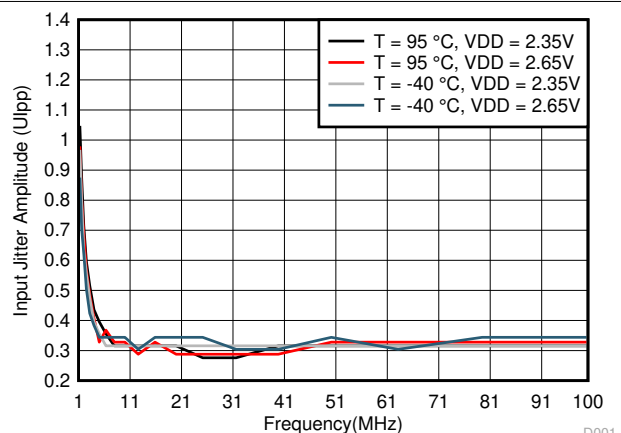

1 MHz to 100 MHz Input Random Jitter = 0.078 Ujpp

7-6. Typical Input Jitter Tolerance for 30-dB Channel at 25.78125 Gbps

## 8 Detailed Description

### 8.1 Overview

The DS250DF230 is a dual-channel multi-rate retimer with integrated signal conditioning. Each of the two channels operates independently. Each channel includes a continuous-time linear equalizer (CTLE) and a Decision Feedback Equalizer (DFE), which together compensate for the presence of a dispersive transmission channel between the source transmitter and the DS250DF230 receiver. The CTLE and DFE are self-adaptive.

Each channel includes an independent voltage-controlled oscillator (VCO) and phase-locked loop (PLL) which produce a clean clock that is frequency-locked to the clock embedded in the input data stream. The high-frequency jitter on the incoming data is attenuated by the PLL, producing a clean clock with substantially reduced jitter. This clean clock is used to re-time the incoming data, removing high-frequency jitter from the data stream and reproducing the data on the output with significantly reduced jitter.

Each channel of the DS250DF230 features an output driver with adjustable differential output voltage and output equalization in the form of a three-tap finite impulse response (FIR) filter. The output FIR compensates for dispersion in the transmission channel at the output of the DS250DF230.

A full 2x2 cross-point switch is integrated inside. This allows multiplexing and de-multiplexing/fanout applications for fail-over redundancy, as well as cross-over applications to aid PCB routing.

Each channel also includes diagnostic features such as a Pseudo-Random Bit Sequence (PRBS) pattern generator and checker, as well as a non-destructive, eye-opening monitor (EOM). The EOM can be used to plot the post-equalized eye at the input to the decision slicer or simply to read the horizontal eye opening (HEO) and vertical eye opening (VEO).

The DS250DF230 is configurable through a single SMBus port. The DS250DF230 can also act as an SMBus master to configure itself from an external EEPROM. Up to sixteen DS250DF230 devices can share a single SMBus.

The sections which follow describe the functionality of various circuits and features within the DS250DF230. For more information about how to program or operate these features, consult the [DS250DF230 Programmer's Guide](#) (SNLU182).

### 8.2 Functional Block Diagram

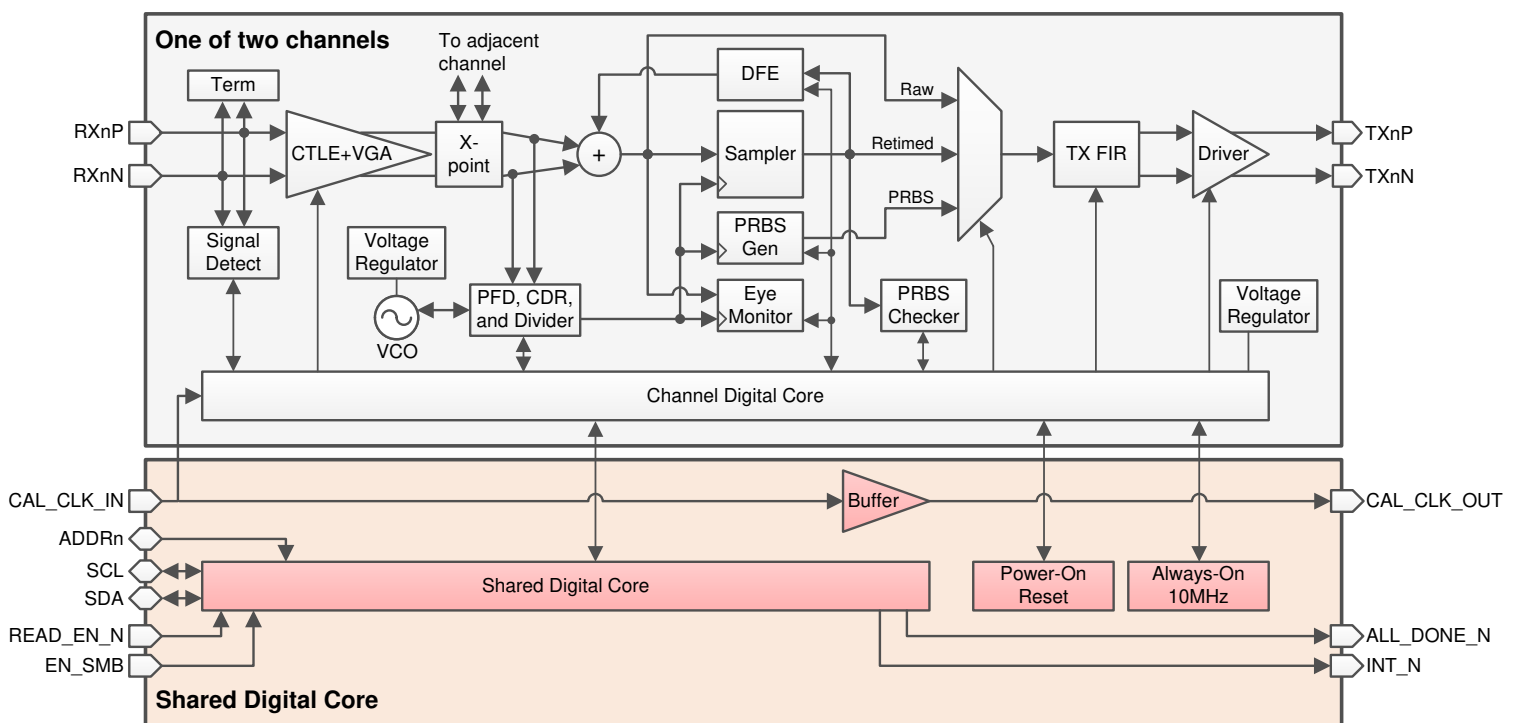

## 8.3 Feature Description

### 8.3.1 Device Data Path Operation

The DS250DF230 data path consists of several key blocks as shown in the functional block diagram. These key circuits are:

- [Signal Detect](#)
- [Continuous Time Linear Equalizer \(CTLE\)](#)
- [Variable Gain Amplifier \(VGA\)](#)
- [Cross-Point Switch](#)
- [Decision Feedback Equalizer \(DFE\)](#)
- [Clock and Data Recovery \(CDR\)](#)
- [Calibration Clock](#)
- [Differential Driver With FIR Filter](#)

### 8.3.2 Signal Detect

The DS250DF230 receiver contains a signal detect circuit. The signal detect circuit monitors the energy level on the receiver inputs and powers on or off the rest of the high-speed data path if a signal is detected or not. By default, each channel allows the signal detect circuit to automatically power on or off the rest of the high-speed data path depending on the presence of an input signal. The signal detect block can be manually controlled in the SMBus channel registers. This can be useful if it is desired to manually force channels to be disabled. For information on how to manually operate the signal detect circuit, refer to the [DS250DF230 Programmer's Guide](#) (SNLU182).

### 8.3.3 Continuous Time Linear Equalizer (CTLE)

The CTLE in the DS250DF230 is a fully-adaptive equalizer. The CTLE adapts according to a Figure of Merit (FOM) calculation during the lock acquisition process. The FOM calculation is based upon the horizontal eye opening (HEO) and vertical eye opening (VEO). Once the CDR locks and the CTLE adapts, the CTLE boost level is frozen until a manual re-adapt command is issued or until the CDR re-enters the lock acquisition state. The CTLE can be re-adapted by resetting the CDR.

The CTLE consists of 4 stages, with each stage having 2-bit boost control. This allows for many boost combinations, including bypassing the first three stages EQs. The CTLE adaption algorithm allows the CTLE to adapt through 20 of these boost combinations. These 20 boost combinations comprise the EQ Table in the channel registers. See channel registers 0x40 through 0x53.

The boost levels can be set between approximately 0 dB and 25 dB (at 12.89 GHz.)

### 8.3.4 Variable Gain Amplifier (VGA)

The DS250DF230 receiver implements a VGA. The VGA assists in the recovery of extremely small signals, working in conjunction with the CTLE to equalize and scale amplitude. The VGA has 1-bit control through Reg\_0x8E[0], and the VGA is in the low-gain state (Reg\_0x8E[0]=0) by default. In addition to the VGA, the CTLE implements its own gain control through Reg\_0x13[5] to adjust the DC amplitude similar to the VGA. For more information on how to configure the VGA and EQ gain, refer to the [DS250DF230 Programmer's Guide](#) (SNLU182).

### 8.3.5 Cross-Point Switch

DS250DF230 has a 2×2 cross-point that may be enabled to implement a 2-to-1 mux, a 1-to-2 fanout, or an A-to-B/B-to-A lane cross.

### 8.3.6 Decision Feedback Equalizer (DFE)

A 5-tap DFE can be enabled within the data path of each channel to assist in reducing the effects of crosstalk, reflections, or post-cursor, inter-symbol interference (ISI). The DFE must be manually enabled, regardless of the selected adapt mode. Once the DFE is enabled, it can be configured to adapt only during lock acquisition or to adapt continuously. The DFE can also be manually configured to specified tap polarities and tap weights. However, when the DFE is configured manually, the DFE auto-adaptation must be disabled. For many applications with lower insertion loss (that is, < 30 dB) lower crosstalk, and/or lower reflections, part or all of the DFE can be disabled to reduce power consumption. The DFE can either be fully enabled (taps 1-5), partially enabled (taps 1-2 only), or fully disabled (no taps). The DFE taps support continuous adaptation, the device is capable of compensating large channel loss variation over temperature

The DFE taps are all feedback taps with 1UI spacing. Each tap has a specified boost weight range and polarity bit.

**表 8-1. DFE Tap Weights**

DFE PARAMETER	DECIMAL (REGISTER VALUE)	VALUE (mV) (TYP)
Tap 1 Weight Range	0 - 31	0 – 217
Tap 2-5 Weight Range	0 - 15	0 – 105
Tap Weight Step Size	NA	7
Polarity	0: (+) positive; feedback value creates a low-pass filter response, thus providing attenuation to correct for negative-sign, post-cursor ISI 1: (-) negative; Feedback value creates a high-pass filter response, thus providing boost to correct for positive-sign, post-cursor ISI.	

### 8.3.7 Clock and Data Recovery (CDR)

The CDR consists of a Phase-Locked Loop (PLL), PPM counter, and Input and Output Data Multiplexers (mux) that allow for retimed data, non-retimed data, a PRBS generator, and output muted modes.

By default, the equalized data is fed into the CDR for clock and data recovery. The recovered data is then output to the FIR filter and differential driver together with the recovered clock that was cleaned of any high-frequency jitter outside the bandwidth of the CDR clock recovery loop. The bandwidth of the CDR defaults to 4.7 MHz (typical) in full-rate (divide-by-1) mode and 4 MHz (typical) in sub-rate mode. The CDR bandwidth is adjustable. Refer to the [DS250DF230 Programmer's Guide](#) (SNLU182) for more information on adjusting the CDR bandwidth. Users can configure the CDR data to route the recovered clock and data to the PRBS checker. Users also have the option of configuring the output of the CDR to send raw non-retimed data, or data from the pattern generator.

The CDR requires these items for proper configuration:

- A 30.72-MHz or 25-MHz calibration clock to run the PPM counter (CAL\_CLK\_IN).
- Expected data rates must be programmed into the CDR either through the rate table or entered manually with the corrected divider settings. Refer to the [DS250DF230 Programmer's Guide](#) (SNLU182) for more information on configuring the CDR for different data rates.

The DS250DF230 offers a low-speed recovered clock for channel 0. This feature is useful for the cases when recovered clock from FPGA or ASIC has in-band spurs on the phase noise plot because of the digital switching noise. See the [表 8-6](#) for the recovered clock frequency versus input data rate.

#### 8.3.7.1 CDR Bypass (Raw) Mode

When DS250DF230 is configured to CDR Bypass (Raw) Mode, the output differential voltage amplitude of the transmitter is adjustable. See the  $V_{OD\_Raw\_L}$  and  $V_{OD\_Raw\_H}$  parameters from [Electrical Characteristics](#). When switching from Raw Mode to Retimed Mode (CDR Enabled), REG\_0x1A[7:6] and REG\_0x0D[0] values need to be changed back to default. Refer to the [DS250DF230 Programmer's Guide](#) (SNLU182) for more information.

### 8.3.7.2 CDR Fast Lock Mode

The DS250DF230 offers a CDR Fast Lock Mode option to enable a CDR lock time as fast as 2 ms. See CDR lock time parameter in [Electrical Characteristics](#).

Normally, CDR acquisition lock time is gated by multiple factors, most notably until a minimum horizontal and vertical eye opening (HEO/VEO) is observed at the receiver, causing typical CDR lock times of up to 100 ms. In CDR Fast Lock Mode, the DS250DF230 outputs retimed data as soon as CDR lock is achieved based on PPM tolerance and VCO input comparator voltage requirements, removing minimum HEO/VEO requirements. This results in active retimed output data within 10 ms or less. Meanwhile, the EQ adaptation continues to run in the background and adjusts CTLE and DFE settings until optimal. As a result, when in CDR Fast Lock Mode, there may be bit errors observed in the retimed data output until EQ adaptation completes.

#### Note

CDR Fast Lock Mode is intended only for use cases with low input insertion loss where some retimer input eye opening can be ensured for all CTLE table indices. For channels >6dB IL at 13 GHz, it is recommended to disable CDR fast lock and instead decrease the EOM timer threshold (EOM\_TIMER\_THR) value to reduce the CDR lock acquisition time.

### 8.3.8 Calibration Clock

The calibration clock is not part of the CDR's PLL and thus is not used for clock and data recovery. The calibration clock is connected only to the PPM counter for each CDR. The PPM counter constrains the allowable lock ranges of the CDR according to the programmed values in the rate table or the manually entered data rates. The host must provide an input calibration clock signal of 30.72-MHz or 25-MHz frequency. This clock is not used for clock and data recovery, thus there are no stringent jitter requirements placed on this calibration clock.

### 8.3.9 Differential Driver With FIR Filter

The DS250DF230 output driver has a three-tap finite impulse response (FIR) filter which allows for pre- and post-cursor equalization to compensate for a wide variety of output channel media. The filter consists of a weighted sum of three consecutive retimed bits as shown in [Figure 8-1](#). C[0] can take on values in the range [-31, +31]. C[-1] and C[+1] can take on values in the range [-15, 15].

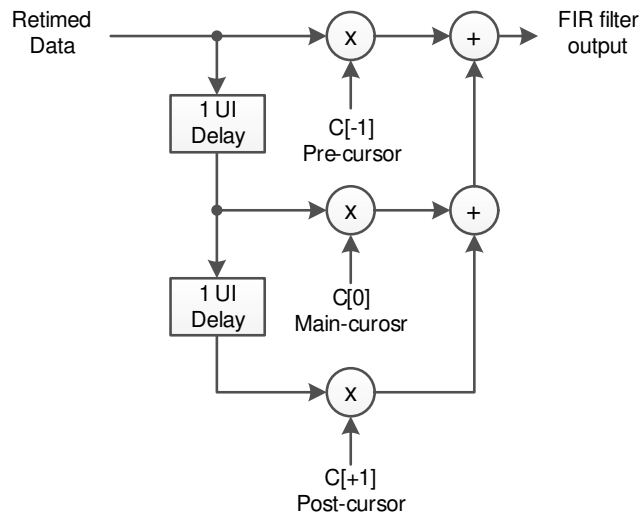

**Figure 8-1. FIR Filter Functional model**

When using the FIR filter, it is important to abide by these general rules:

- $|C[-1]| + |C[0]| + |C[+1]| \leq 31$ ; the FIR tap coefficients absolute sum must be less or equal to 31
- $\text{sgn}(C[-1]) = \text{sgn}(C[+1]) \neq \text{sgn}(C[0])$ , for high-pass filter effect; the sign for the pre-cursor and/or post-cursor tap must be different from main-cursor tap to realize boost effect
- $\text{sgn}(C[-1]) = \text{sgn}(C[+1]) = \text{sgn}(C[0])$ , for low-pass filter effect; the sign for the pre-cursor and/or post-cursor tap must be equal to the main-cursor tap to realize attenuation effect

The FIR filter is used to pre-distort the transmitted waveform to compensate for frequency-dependant loss in the output channel. The most common way of pre-distorting the signal is to accentuate the transitions and de-emphasize the non-transitions. The bit before a transition is accentuated through the pre-cursor tap, and the bit after the transition is accentuated through the post-cursor tap. The waveforms in [Figure 8-2](#) through [Figure 8-4](#) give a conceptual illustration of how the FIR filter affects the output waveform. These characteristics can be derived from the example waveforms:

- $VOD_{pk-pk} = v_7 - v_8$
- $VOD_{low-frequency} = v_2 - v_5$
- $Rpre_{dB} = 20 \times \log_{10}(v_3/v_2)$
- $Rpst_{dB} = 20 \times \log_{10}(v_1/v_2)$

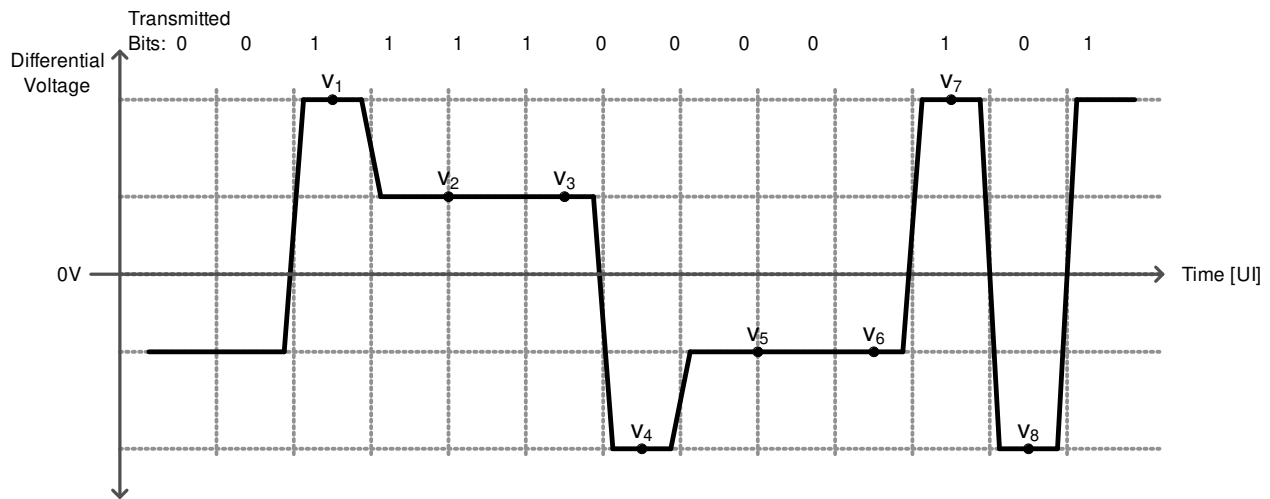

**Figure 8-2. Conceptual FIR Waveform With Post-Cursor Only**

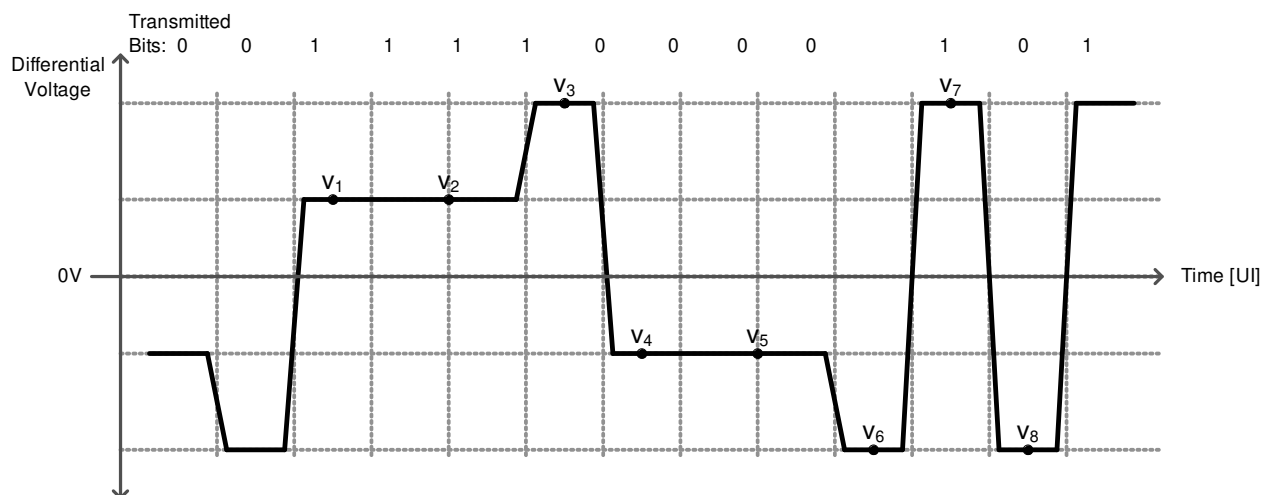

**Figure 8-3. Conceptual FIR Waveform With Pre-Cursor Only**



图 8-4. Conceptual FIR Waveform With Both Pre- and Post-Cursor

### 8.3.9.1 Setting the Output $V_{OD}$ , Pre-Cursor, and Post-Cursor Equalization

The output differential voltage ( $V_{OD}$ ), pre-cursor, and post-cursor equalization of the driver is controlled by manipulating the FIR tap settings. The main cursor tap is the primary knob for amplitude adjustment. The pre- and post-cursor FIR tap settings can then be adjusted to provide equalization. To maintain a constant peak-to-peak VOD, the user must adjust the main cursor tap value relative to the pre- and post-cursor tap changes so as to maintain a constant absolute sum of the FIR tap values. 表 8-2 shows various settings for  $V_{OD}$  settings ranging from 350 mVpp to 1195 mVpp (typical). Note that the output peak-to-peak amplitude is a function of the sum of the absolute values of the taps, whereas the low-frequency amplitude is purely a function of the main-cursor value.

表 8-2. Typical VOD and FIR Values

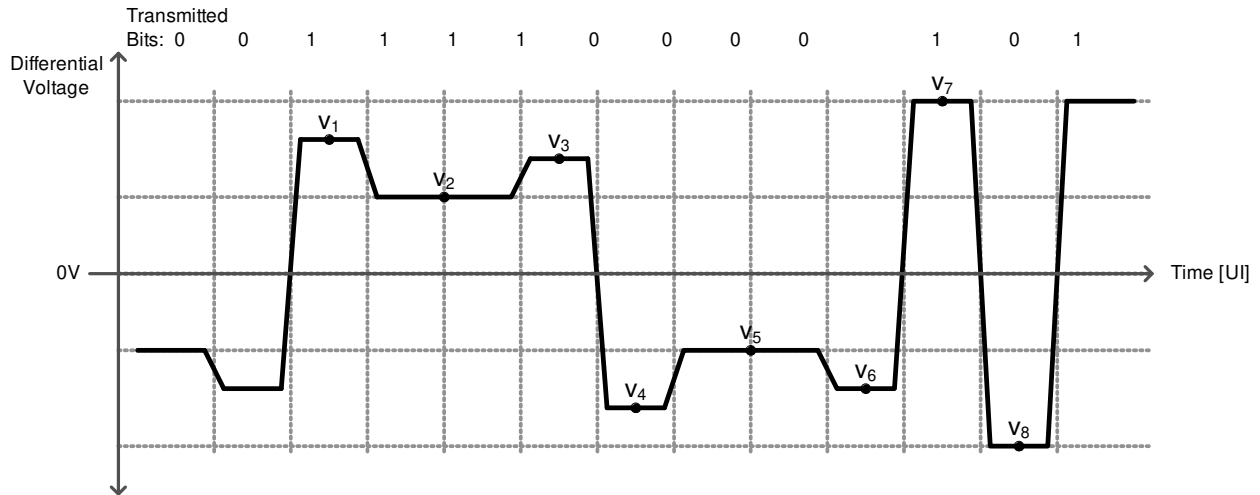
FIR SETTINGS			Peak-to Peak VOD(V)	RPRE(dB)	RPST(dB)
PRE-CURSOR: REG_0x3E[6:0]	MAIN-CURSOR: REG_0x3D[6:0]	POST-CURSOR: REG_0x3F[6:0]			
0	+3	0	0.350	NA	NA
0	+4	0	0.392	NA	NA
0	+5	0	0.436	NA	NA
0	+6	0	0.482	NA	NA
0	+7	0	0.524	NA	NA
0	+8	0	0.562	NA	NA
0	+9	0	0.602	NA	NA
0	+10	0	0.638	NA	NA
0	+11	0	0.678	NA	NA
0	+12	0	0.710	NA	NA
0	+13	0	0.748	NA	NA
0	+14	0	0.782	NA	NA
0	+15	0	0.816	NA	NA
0	+16	0	0.846	NA	NA
0	+17	0	0.880	NA	NA
0	+18	0	0.910	NA	NA
0	+19	0	0.944	NA	NA
0	+20	0	0.968	NA	NA
0	+21	0	0.998	NA	NA

表 8-2. Typical VOD and FIR Values (continued)

FIR SETTINGS			Peak-to Peak VOD(V)	RPRE(dB)	RPST(dB)
PRE-CURSOR: REG_0x3E[6:0]	MAIN-CURSOR: REG_0x3D[6:0]	POST-CURSOR: REG_0x3F[6:0]			
0	+22	0	1.028	NA	NA
0	+23	0	1.056	NA	NA
0	+24	0	1.076	NA	NA
0	+25	0	1.096	NA	NA
0	+26	0	1.120	NA	NA
0	+27	0	1.140	NA	NA
0	+28	0	1.155	NA	NA
0	+29	0	1.175	NA	NA
0	+30	0	1.185	NA	NA
0	+31	0	1.195	NA	NA
0	+16	-1	0.880	NA	2.0
0	+15	-2	0.880	NA	2.7
0	+14	-3	0.880	NA	3.4
0	+13	-4	0.880	NA	4.3
0	+12	-5	0.880	NA	5.4
0	+11	-6	0.880	NA	6.7
0	+10	-7	0.880	NA	8.4
0	+9	-8	0.880	NA	11
-1	+16	0	0.880	0.7	NA
-2	+15	0	0.880	1.5	NA
-3	+14	0	0.880	2.5	NA
-4	+13	0	0.880	3.5	NA
0	+30	-1	1.195	NA	0.6
0	+29	-2	1.195	NA	0.8
0	+28	-3	1.195	NA	1.1
0	+27	-4	1.195	NA	1.4
0	+26	-5	1.195	NA	1.8
0	+25	-6	1.195	NA	2.3
0	+24	-7	1.195	NA	2.8
0	+23	-8	1.195	NA	3.4
0	+22	-9	1.195	NA	4.1
0	+21	-10	1.195	NA	4.9
0	+20	-11	1.195	NA	5.9
0	+19	-12	1.195	NA	6.9
-1	+30	0	1.195	0.4	NA
-2	+29	0	1.195	0.6	NA
-3	+28	0	1.195	0.9	NA
-4	+27	0	1.195	1.3	NA
-5	+26	0	1.195	1.7	NA
-6	+25	0	1.195	2.1	NA
-7	+24	0	1.195	2.7	NA

The recommended pre-cursor and post-cursor settings for a given channel will depend on the channel characteristics (mainly insertion loss) as well as the equalization capabilities of the downstream receiver. The DS250DF230 receiver, with its highly-capable CTLE and DFE, does not require a significant amount of pre- or post-cursor. The guidelines in [8-5](#) through [8-7](#) give general recommendations for pre- and post-cursor for different channel loss conditions. The insertion loss (IL) in these plots refers to the total loss between the link partner transmitter and the DS250DF230 receiver.

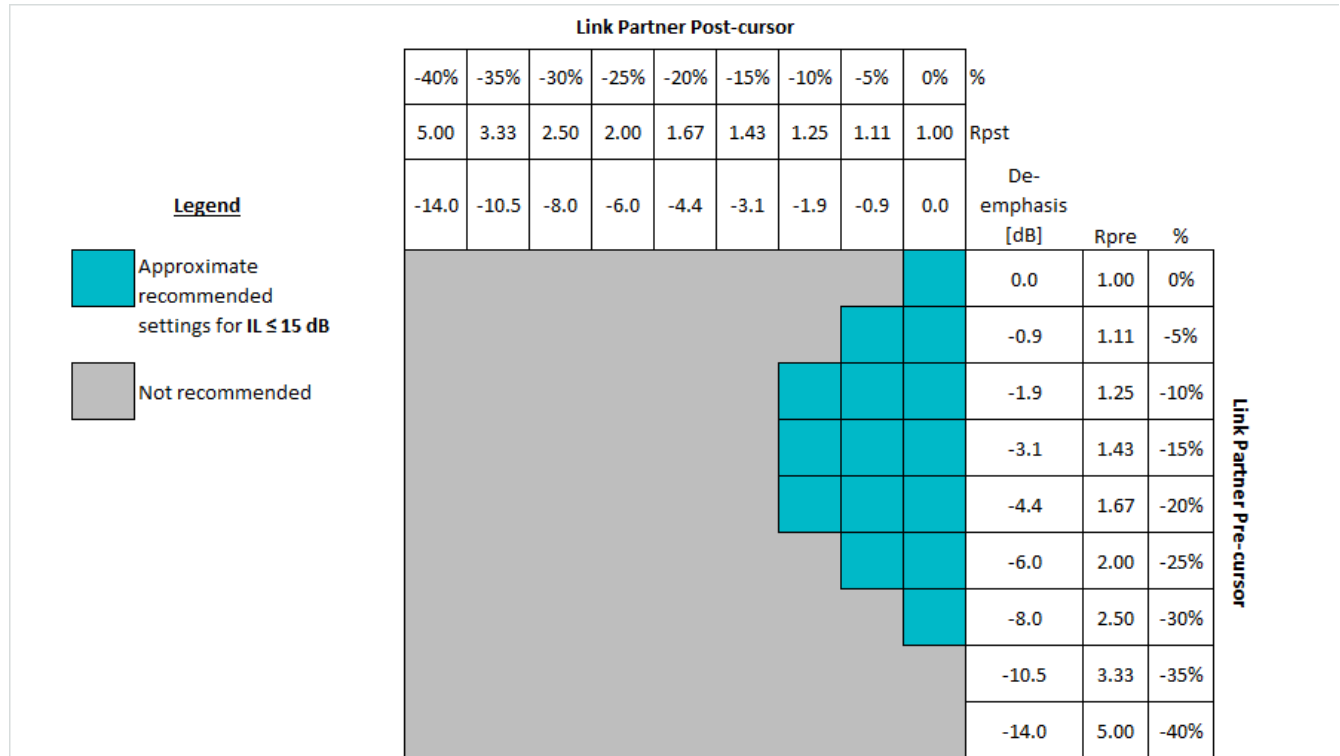

**8-5. Guideline for Link Partner FIR Settings When IL ≤ 15 dB**

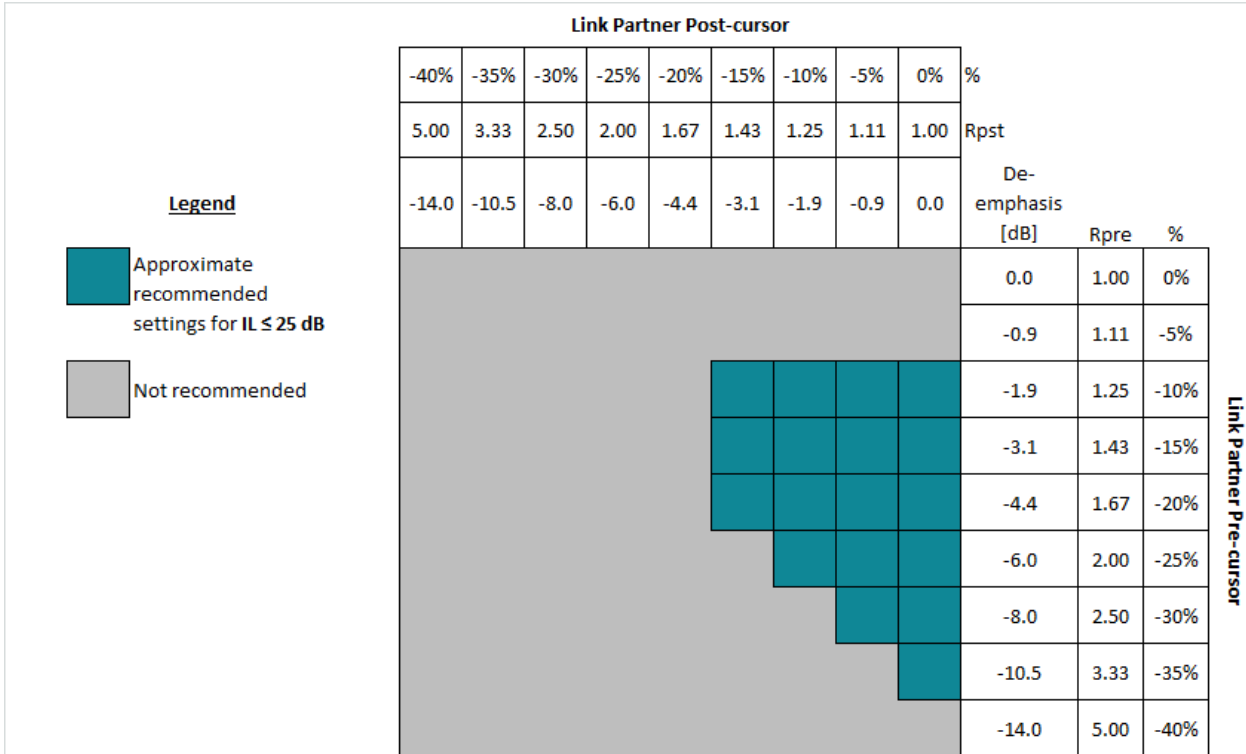

**8-6. Guideline for Link Partner FIR Settings When IL ≤ 25 dB**

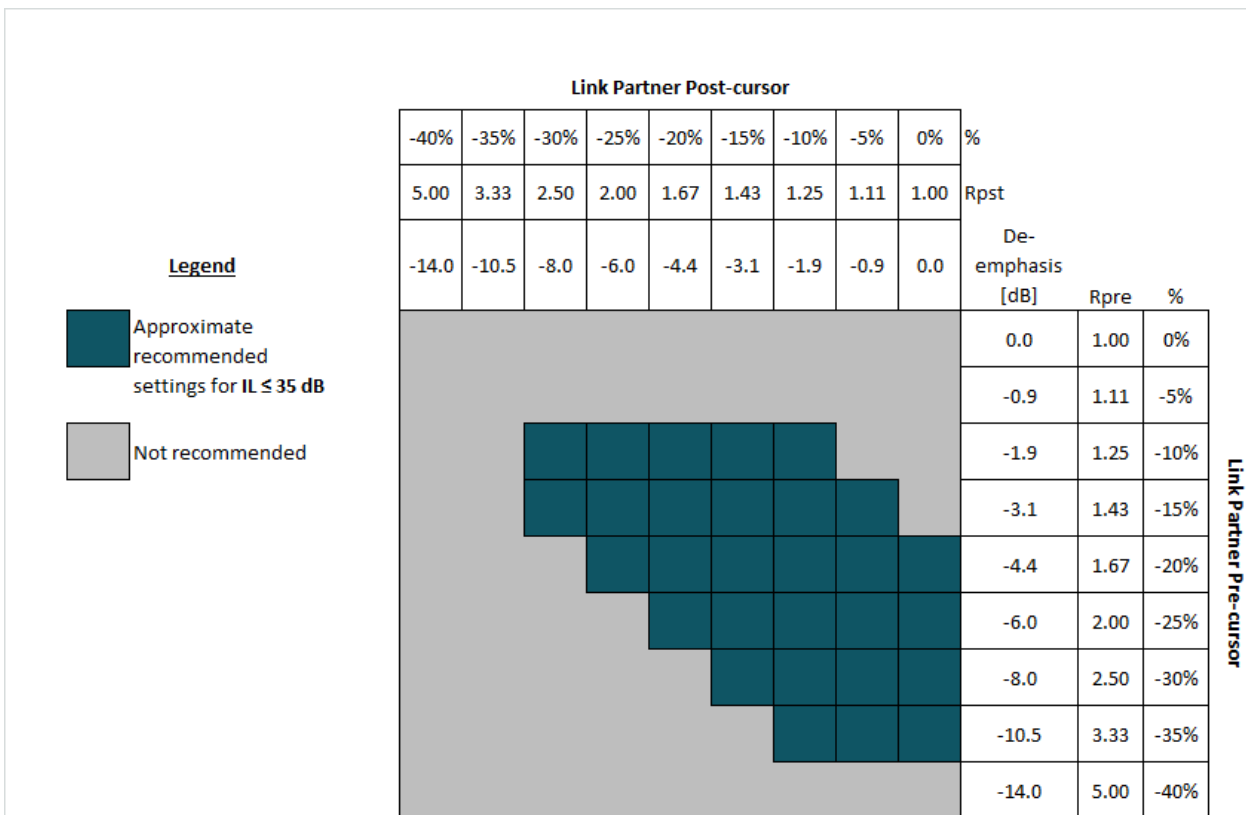

**8-7. Guideline for Link Partner FIR Settings When IL ≤ 35 dB**

### 8.3.9.2 Output Driver Polarity Inversion

In some applications, it may be necessary to invert the polarity of the data transmitted from the retimer. To invert the polarity of the data, read back the FIR polarity settings for the pre-, main and post-cursor taps and then invert these bits.

### 8.3.9.3 Slow Slew Rate

In some low speed applications, it may be needed to adjust the slew rate of the data transmitted from the retimer. DS250DF230 does offer this option. See output transition-time parameter from [Electrical Characteristics](#). It is not recommended to use the slow rate setting for divide-by-1 data rate applications.

## 8.3.10 Debug Features

### 8.3.10.1 Pattern Generator

Each channel in the DS250DF230 can be configured to generate a 16-bit user-defined data pattern or a pseudo-random bit sequence (PRBS). The user defined pattern can also be set to automatically invert every other 16-bit symbol for DC balancing purposes. The DS250DF230 pattern generator supports the following PRBS sequences:

- PRBS –  $2^7 - 1$
- PRBS –  $2^9 - 1$
- PRBS –  $2^{11} - 1$
- PRBS –  $2^{15} - 1$
- PRBS –  $2^{23} - 1$
- PRBS –  $2^{31} - 1$

### 8.3.10.2 Pattern Checker

The pattern checker can be manually set to look for specific PRBS sequences and polarities or it can be set to automatically detect the incoming pattern and polarity. The PRBS checker supports the same set of PRBS patterns as the PRBS generator.

The pattern checker consists of an 11-bit error counter. The pattern checker uses 32-bit words, but every bit in the word is checked for error, so the error count represents the count of single bit errors.

To read out the bit and error counters, the pattern checker must first be frozen. Continuous operation with simultaneous read out of the bit and error counters is not supported in this implementation. Once the bit and error counter is read, they can be unfrozen to continue counting.

### 8.3.10.3 Eye-Opening Monitor

The DS250DF230's Eye-Opening Monitor (EOM) measures the internal data eye at the input of the decision slicer and can be used for 2 functions:

1. Horizontal Eye Opening (HEO) and Vertical Eye Opening (VEO) measurement
2. Full Eye Diagram Capture

The HEO measurement is made at the 0 V crossing and is read in channel register 0x27. The VEO measurement is made at the 0.5 UI mark and is read in channel register 0x28. The HEO and VEO registers can be read from channel registers 0x27 and 0x28 at any time while the CDR is locked. The following equations are used to convert the contents of channel registers 0x27 and 0x28 into their appropriate units:

- $\text{HEO [UI]} = \text{Reg\_0x27} \div 32$
- $\text{VEO [mV]} = \text{Reg\_0x28} \times 3.125$

A full eye diagram capture can be performed when the CDR is locked. The eye diagram is constructed within a  $64 \times 64$  array, where each cell in the matrix consists of an 16-bit word representing the total number of hits recorded at that particular phase and voltage offset. Users can manually adjust the vertical scaling of the EOM or allow the state machine to control the scaling which is the default option. The horizontal scaling controlled by the state machine is always directly proportional to the data rate.

When a full eye diagram plot is captured, the retimer will shift out four 16-bit words of residual data that must be discarded followed by 4096 16-bit words that make up the  $64 \times 64$  eye plot. The first actual word of the eye plot from the retimer is for (X, Y) position (0,0), which is the earliest position in time and the most negative position in voltage. Each time the eye plot data is read out, the voltage position is incremented. Once the voltage position has incremented to position 63 (the most positive voltage), the next read will cause the voltage position to reset to 0 (the most negative voltage) and the phase position to increment. This process will continue until the entire  $64 \times 64$  matrix is read out. [Figure 8-8](#) shows the EOM read out sequence overlaid on top of a simple eye opening plot. In this plot any hits are shown in green. This type of plot is helpful for quickly visualizing the HEO and VEO. Users can apply different algorithms to the output data to plot density or color gradients to the output data.

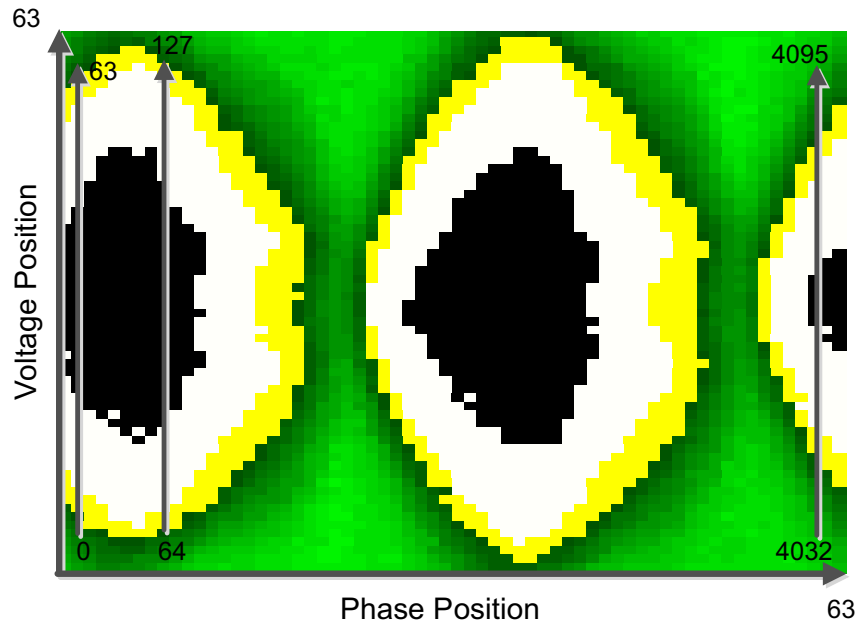

**Figure 8-8. EOM Full Eye Capture Readout**

To manually control the EOM vertical range, remove scaling control from the state machine then select the desired range:

Channel Reg 0x2C[6] → 0 (see [Table 8-3](#)).

**Table 8-3. Eye-Opening Monitor Vertical Range Settings**

CH REG 0x11[7:6] VALUE	EOM VERTICAL RANGE [mV]
2'b00	±100
2'b01	±200
2'b10	±300
2'b11	±400

The EOM operates as an under-sampled circuit. This allows the EOM to be useful in identifying over equalization, ringing and other gross signal conditioning issues. However, the EOM cannot be correlated to a bit error rate.

The EOM can be accessed in two ways to read out the entire eye plot:

- Multi-byte reads can be used such that data is repeatedly latched out from channel register 0x25.
- With single byte reads, the MSB are located in register 0x25 and the LSB are located in register 0x26. In this mode, the device must be addressed each time a new byte is read.

To perform a full eye capture with the EOM, follow the steps listed in [Table 8-4](#) within the desired channel register set:

**表 8-4. Eye-Opening Monitor Full Eye Capture Instructions**

STEP	REGISTER [bits]	Operation	VALUE	DESCRIPTION
1	0x67[5]	Write	0	Disable lock EOM lock monitoring
2	0x2C[6]	Write	0	Set the desired EOM vertical range
	0x11[7:6]	Write	2'b--	
3	0x11[5]	Write	0	Power on the EOM
4	0x24[7]	Write	1	Enable fast EOM
5	0x24[0]	Read	1	Begin read out of the 64 × 64 array, discard first 4 words Ch reg 0x24[0] is self-clearing.
	0x25			0x25 is the MSB of the 16-bit word
	0x26			0x26 is the LSB of the 16-bit word
6	0x25	Read		Continue reading information until the 64 × 64 array is complete.
	0x26			
7	0x67[5]	Write	1	Return the EOM to its original state. Undo steps 1-4
	0x2C[6]	Write	1	
	0x11[5]	Write	1	
	0x24[7]	Write	0	

### 8.3.11 Interrupt Signals

The DS250DF230 can be configured to report different events as interrupt signals. These interrupt signals do not impact the operation of the device, but merely report that the selected event has occurred. The interrupt bits in the register sets are all sticky bits. This means that when an event triggers an interrupt the status bit for that interrupt is set to logic HIGH. This interrupt status bit will remain at logic HIGH until the bit has been read. Once the bit has been read it will be automatically cleared, which allows for new interrupts to be detected. The DS250DF230 will report the occurrence of an interrupt through the INT\_N pin. The INT\_N pin is an open-drain output that will pull the line low when an interrupt signal is triggered.

Note that all available interrupts are disabled by default. Users must activate the various interrupts before they can be used.

The interrupts available in the DS250DF230 are:

- CDR loss of lock
- CDR locked
- Signal detect loss
- Signal detected
- PRBS pattern checker bit error detected
- HEO/VEO threshold violation

When an interrupt occurs, share register 0x08 reports which channel generated the interrupt request. Users can then select one or more of the channels that generated the interrupt request and service the interrupt by reading the appropriate interrupt status bits in the corresponding channel registers. For more information on reading interrupt status, refer to the [DS2x0DF810](#), [DS250DFx10](#), [DS250DF230 Programmer's Guide](#).

## 8.4 Device Functional Modes

### 8.4.1 Supported Data Rates

The DS250DF230 supports a wide range of input data rates, including divide-by-2 and divide-by-4 sub-rates. The supported data rates are listed in [表 8-5](#).

**表 8-5. Supported Data Rates**

DATA RATE RANGE		DIVIDER	CDR MODE	COMMENT
MIN	MAX			
≥ 19.6 Gbps	≤ 25.8 Gbps	1	Enabled	
> 12.9 Gbps	<19.6 Gbps	N/A	Bypassed	Output jitter will be higher with CDR bypassed.
≥ 9.8 Gbps	≤ 12.9 Gbps	2	Enabled	
> 6.45 Gbps	< 9.8 Gbps	N/A	Bypassed	Output jitter will be higher with CDR bypassed.
≥ 4.9 Gbps	6.45 ≤ Gbps	4	Enabled	
	< 4.9 Gbps	N/A	Bypassed	Output jitter will be higher with CDR bypassed.

The device can be configured to operate at different standard data rates by programming the Rate/Sub-Rate register Reg\_2F[7:4]. For more information on data rate programming, refer to the [DS2x0DF810](#), [DS250DFx10](#), [DS250DF230 Programmer's Guide](#).

**表 8-6. Rate/Sub-Rate Table<sup>(1)</sup>**

RATE Reg_0x2F[7:4]	Standard	Input Data Rates [Gbps]	Recovered Clock Frequency [MHz]
0	CPRI Option 9	12.16512	30.72
1	CPRI Option 7	9.83040	30.72
2	CPRI Option 8	10.13760	30.72
3	CPRI Option 10	24.33024	30.72
4	CPRI Option 5	4.91520	30.72
5 (Default)	100GbE	25.78125	32.2265625
6	100GbE/ 40GbE/ 10GbE	25.78125	32.2265625
		10.31250	32.2265625
7	40GbE/ 10GbE	10.31250	32.2265625
8	CPRI Option 6	6.14400	30.72

- (1) This table is valid only when the calibration clock is 30.72-MHz. Refer to the [DS2x0DF810](#), [DS250DFx10](#), [DS250DF230 Programmer's Guide](#) for more information.

### 8.4.2 SMBus Master Mode

SMBus master mode allows the DS250DF230 to program itself by reading directly from an external EEPROM. When using the SMBus master mode, the DS250DF230 will read directly from specific location in the external EEPROM. When designing a system for using the external EEPROM, the user must follow these specific guidelines:

- Maximum EEPROM size is 2048 Bytes
- Minimum EEPROM size for a single DS250DF230 with individual channel configuration is 161 Bytes (3 base header bytes + 12 address map bytes + 2 × 72 channel register bytes + 2 share register bytes; bytes are defined to be 8-bits)
- Set ENSMB = Float, for SMBus master mode
- The external EEPROM device address byte must be 0xA0
- The external EEPROM device must support 400kHz operation at 2.5-V or 3.3-V supply
- THR pin is pulled low by 1 kΩ to GND, so that DS250DF230 is working under 2.5-V/3.3-V SMBus interface mode
- Set the SMBus address of the DS250DF230 by configuring the ADDR0 and ADDR1 pins

When loading multiple DS250DF230 devices from the same EEPROM, use these guidelines to configure the devices:

- Configure the SMBus addresses for each DS250DF230 to be sequential. The first device in the sequence must have an address of 0x30
- Daisy chain READ\_EN\_N and ALL\_DONE\_N from one device to the next device in the sequence so that they do not compete for the EEPROM at the same time.
- If all of the DS250DF230 devices share the same EEPROM channel and share register settings, configure the common channel bit in the base header to 1. With common channel configuration enabled, each DS250DF230 device will configure all 2 channels with the same settings.

When loading a single DS250DF230 from an EEPROM, use these guidelines to configure the device:

- Set the common channel bit to 0 to allow for individual channel configuration, or set the common channel bit to 1 to load the same configuration settings to all channels.
- When configuring individual channels, a 512, 1024 or 2048 Byte EEPROM must be used.
- If there are more than three DS250DF230 devices on a PCB that require individual channel configuration, then each device must have its own EEPROM.

### 8.4.3 Device SMBus Address

The DS250DF230's SMBus slave address is strapped at power up using the ADDR[1:0] pins. The pin state is read on power up, after the internal power-on reset signal is de-asserted. The ADDR[1:0] pins are four-level LVCMOS IOs, which provides for 16 unique SMBus addresses. The four levels are achieved by pin strap options as follows:

- 0: 1 kΩ to GND
- R: 10 kΩ to GND (20 kΩ also acceptable)
- F: Float
- 1: 1 kΩ to VDD

**表 8-7. SMBus Address Map**

8-BIT WRITE ADDRESS [HEX]	REQUIRED ADDRESS PIN STRAP VALUE	
	ADDR1	ADDR0
0x30	0	0
0x32	0	R
0x34	0	F
0x36	0	1
0x38	R	0
0x3A	R	R
0x3C	R	F
0x3E	R	1
0x40	F	0
0x42	F	R
0x44	F	F
0x46	F	1
0x48	1	0
0x4A	1	R
0x4C	1	F
0x4E	1	1

## 8.5 Programming

### 8.5.1 Bit Fields in the Register Set

Many of the registers in the DS250DF230 are divided into bit fields. This allows a single register to serve multiple purposes which may be unrelated. Often, configuring the DS250DF230 requires writing a bit field that makes up only part of a register value while leaving the remainder of the register value unchanged. The procedure for accomplishing this task is to read in the current value of the register to be written, modify only the desired bits in this value, and write the modified value back to the register. Of course, if the entire register is to be changed, rather than just a bit field within the register, it is not necessary to read in the current value of the register first. In all register configuration procedures described in the following sections, this procedure must be kept in mind. In some cases, the entire register is to be modified. When only a part of the register is to be changed, however, the procedure described above must be used.

Most register bits can be read or written to. However, some register bits are constrained to specific interface instructions.

Register bits can have the following interface constraints:

- R - Read only
- RW - Read/Write
- RWSC - Read/Write, self-clearing

### 8.5.2 Writing to and Reading from the Global/Shared/Channel Registers

The DS250DF230 has 3 types of registers:

1. Global Registers – These registers can be accessed at any time and are used to select individual channel registers, the shared registers or to read back the TI ID and version information.
2. Shared Registers – These registers are used for device-level configuration, status read back or control.
3. Channel Registers – These registers are used to control and configure specific features for each individual channel. All channels have the same channel register set and can be configured independent of each other.

The global registers can be accessed at any time, regardless of whether the shared or channel register set is selected. The DS250DF230 global registers are located on addresses 0xEF-0xFF. The function of the global registers falls into the following categories:

- Channel selection and share enabling – Registers 0xFC and 0xFF
- Device and version information – Registers 0xEF-0xF3
- Reserved/unused registers – all other addresses

Register 0xFC is used to select the channel registers to be written to. To select a channel, write a 1 to its corresponding bit in register 0xFC. Note that more than one channel may be written to by setting multiple bits in register 0xFC. However, when performing an SMBus read transaction only one channel can be selected at a time. If multiple channels are selected in register 0xFC when attempting to perform an SMBus read, the device will return 0xFF.

Register 0xFF bit 1 can be used to perform broadcast register writes to all channels. A single channel read-modify broadcast write type commands can be accomplished by setting register 0xFF to 0x03 and selecting a single channel in register 0xFC. This type of configuration allows for the reading of a single channel's register information and then writing to all channels with the modified value. Register 0xFF bit 0 is used to select the shared register page or the channel register page for the channels selected in register 0xFC.

TI repeaters/retimers have a vendor ID register (0xFE) which will always read back 0x03. In addition, there are three device ID registers (0xF0, 0xF1, and 0xF3). These are useful to verify that there is a good SMBus connection between the SMBus master and the DS250DF230.

## 8.6 Register Maps

表 8-8. Global Registers

ADDRESS (HEX)	BITS	DEFAULT VALUE (HEX)	MODE	EEPROM	FIELD NAME	DESCRIPTION
EF	7	0	R	N	SPARE	
	6	0	R	N	SPARE	
	5	0	R	N	SPARE	
	4	0	R	N	SPARE	
	3	1	R	N	CHAN_CONFIG_ID[3]	TI device ID (Quad count). DS250DF230: 0x0E
	2	1	R	N	CHAN_CONFIG_ID[2]	
	1	1	R	N	CHAN_CONFIG_ID[1]	
	0	0	R	N	CHAN_CONFIG_ID[0]	
F0	7	0	R	N	VERSION[7]	TI version ID DS250DF230: 0x01
	6	0	R	N	VERSION[6]	
	5	0	R	N	VERSION[5]	
	4	0	R	N	VERSION[4]	
	3	0	R	N	VERSION[3]	
	2	0	R	N	VERSION[2]	
	1	0	R	N	VERSION[1]	
	0	1	R	N	VERSION[0]	
F1	7	0	R	N	DEVICE_ID[7]	Device ID DS250DF230: 0x15
	6	0	R	N	DEVICE_ID[6]	
	5	0	R	N	DEVICE_ID[5]	
	4	1	R	N	DEVICE_ID[4]	
	3	0	R	N	DEVICE_ID[3]	
	2	1	R	N	DEVICE_ID[2]	
	1	0	R	N	DEVICE_ID[1]	
	0	1	R	N	DEVICE_ID[0]	
F3	7	0	R	N	CHAN_VERSION[3]	Digital Share Version
	6	0	R	N	CHAN_VERSION[2]	
	5	0	R	N	CHAN_VERSION[1]	
	4	0	R	N	CHAN_VERSION[0]	
	3	0	R	N	SHARE_VERSION[3]	Digital Share Version
	2	0	R	N	SHARE_VERSION[2]	
	1	0	R	N	SHARE_VERSION[1]	
	0	0	R	N	SHARE_VERSION[0]	

**表 8-8. Global Registers (continued)**

ADDRESS (HEX)	BITS	DEFAULT VALUE (HEX)	MODE	EEPROM	FIELD NAME	DESCRIPTION
FB	7	0	RW	N	RESERVED	RESERVED
	6	0	RW	N	RESERVED	RESERVED
	5	0	RW	N	RESERVED	RESERVED
	4	0	RW	N	RESERVED	RESERVED
	3	0	RW	N	RESERVED	RESERVED
	2	1	RW	N	RESERVED	RESERVED
	1	0	RW	N	RESERVED	RESERVED
	0	0	RW	N	RESERVED	RESERVED
FC	7	0	RW	N	EN_CH7	
	6	0	RW	N	EN_CH6	
	5	0	RW	N	EN_CH5	
	4	0	RW	N	EN_CH4	
	3	0	RW	N	EN_CH3	
	2	0	RW	N	EN_CH2	
	1	0	RW	N	EN_CH1	Select channel 1
	0	0	RW	N	EN_CH0	Select channel 0
FD	7	0	RW	N	RESERVED	RESERVED
	6	0	RW	N	RESERVED	RESERVED
	5	0	RW	N	RESERVED	RESERVED
	4	0	RW	N	RESERVED	RESERVED
	3	0	RW	N	RESERVED	RESERVED
	2	0	RW	N	RESERVED	RESERVED
	1	0	RW	N	RESERVED	RESERVED
	0	0	RW	N	RESERVED	RESERVED
FE	7	0	R	N	VENDOR_ID[7]	TI vendor ID
	6	0	R	N	VENDOR_ID[6]	
	5	0	R	N	VENDOR_ID[5]	
	4	0	R	N	VENDOR_ID[4]	
	3	0	R	N	VENDOR_ID[3]	
	2	0	R	N	VENDOR_ID[2]	
	1	1	R	N	VENDOR_ID[1]	
	0	1	R	N	VENDOR_ID[0]	

表 8-8. Global Registers (continued)

ADDRESS (HEX)	BITS	DEFAULT VALUE (HEX)	MODE	EEPROM	FIELD NAME	DESCRIPTION
FF	7	0	RW	N	RESERVED	RESERVED
	6	0	RW	N	RESERVED	RESERVED
	5	0	RW	N	EN_SHARE_Q1	Select shared registers for quad 1 (DS250DF810, DS280DF810 only) DS250DF230: 0
	4	0	RW	N	EN_SHARE_Q0	Select shared registers for quad 0
	3	0	RW	N	RESERVED	RESERVED
	2	0	RW	N	RESERVED	RESERVED
	1	0	RW	N	WRITE_ALL_CH	Allows user to write to all channels as if they are the same, but only allows read back from the channel specified in 0xFC. Note: EN_CH_SMB must be = 1 or else this function is invalid.
	0	0	RW	N	EN_CH_SMB	1: Enables SMBUS access to the channels specified in Reg_0xFC 0: The shared registers are selected

**表 8-9. Shared Registers**

ADDRESS (HEX)	BITS	DEFAULT VALUE (HEX)	MODE	EEPROM	FIELD NAME	DESCRIPTION
00	7	0	R	N	SMBUS_ADDR[3]	SMBus Address Strapped 7-bit address is 0x18 + SMBus_Addr[3:0]
	6	0	R	N	SMBUS_ADDR[2]	
	5	0	R	N	SMBUS_ADDR[1]	
	4	0	R	N	SMBUS_ADDR[0]	
	3:0	0	R	N	RESERVED	RESERVED
01	7	0	R	N	RESERVED	RESERVED
	6	0	R	N	RESERVED	RESERVED
	5	0	R	N	RESERVED	RESERVED
	4	1	R	N	RESERVED	RESERVED
	3	0	R	N	RESERVED	RESERVED
	2	1	R	N	RESERVED	RESERVED
	1	0	R	N	RESERVED	RESERVED
	0	1	R	N	RESERVED	RESERVED
02	7:0	0	RW	N	RESERVED	RESERVED
03	7:0	0	RW	N	RESERVED	RESERVED
04	7	0	RW	N	RESERVED	RESERVED
	6	0	RWSC	N	RST_I2C_REGS	1: Reset shared registers. This bit is self-clearing. 0: Normal operation
	5	0	RWSC	N	RST_I2C_MAS	1: Reset for SMBus/I2C Master. This bit is self-clearing. 0: Normal operation
	4	0	RW	N	FRC_EEPRM_RD	1: Force EEPROM Configuration 0: Normal operation
	3	1	RW	Y	RESERVED	RESERVED
	2	0	RW	N	RESERVED	RESERVED
	1	0	RW	N	RESERVED	RESERVED
	0	1	RW	N	RESERVED	RESERVED

表 8-9. Shared Registers (continued)

ADDRESS (HEX)	BITS	DEFAULT VALUE (HEX)	MODE	EEPROM	FIELD NAME	DESCRIPTION
05	7	0	RW	N	DISAB_EEPRM_CFG	1: Disable Master Mode EEPROM configuration (if not started; this bit is not effective if EEPROM configuration is already started) 0: Normal operation
	6:5	0	RW	N	RESERVED	RESERVED
	4	1	R	N	EEPROM_READ_DONE	1: SMBus Master mode EEPROM read complete 0: SMBus Master mode EEPROM read not started or not complete
	3	0	RW	N	TEST0_AS_CAL_CLK_IN	1: Use TEST0 as the input for the 25MHz CAL_CLK instead of CAL_CLK_IN. This must be configured for quad0 only. 0: Normal operation. Use CAL_CLK_IN as the input for the 25MHz CAL_CLK.
	2	0	RW	Y	CAL_CLK_INV_DIS	1: Disable the inversion of CAL_CLK_OUT 0: Normal operation. CAL_CLK_OUT is inverted with respect to CAL_CLK_IN.
	1	0	RW	Y	RESERVED	RESERVED
	0	1	RW	Y	RESERVED	RESERVED
06	7:0	0	RW	N	RESERVED	RESERVED

**表 8-9. Shared Registers (continued)**

ADDRESS (HEX)	BITS	DEFAULT VALUE (HEX)	MODE	EEPROM	FIELD NAME	DESCRIPTION
08	7	0	R	N	RESERVED	RESERVED
	6	0	R	N	RESERVED	RESERVED
	5	0	R	N	RESERVED	RESERVED
	4	0	R	N	RESERVED	RESERVED
	3	0	R	N	INT_Q0C3	Interrupt from channel 3. For DS250DF810 and DS280DF810, this applies to the quad selected by Reg_0xFF[5:4]. Not applicable to DS250DF210
	2	0	R	N	INT_Q0C2	Interrupt from channel 2. For DS250DF810 and DS280DF810, this applies to the quad selected by Reg_0xFF[5:4]. Not applicable to DS250DF210
	1	0	R	N	INT_Q0C1	Interrupt from channel 1. For DS250DF810 and DS280DF810, this applies to the quad selected by Reg_0xFF[5:4].
	0	0	R	N	INT_Q0C0	Interrupt from channel 0. For DS250DF810 and DS280DF810, this applies to the quad selected by Reg_0xFF[5:4].
0A	7:1	0	R	Y	RESERVED	RESERVED
	0	0	RW	Y	DIS_REFCLK_OUT	1: Disable CAL_CLK_OUT (high-Z) 0: Normal operation. Enable CAL_CLK_OUT
0B	7	0	RW	N	RESERVED	RESERVED
	6	0	R	N	REFCLK_DET	1: 25MHz clock detected on CAL_CLK_IN 0: No clock detected on CAL_CLK_IN
	5	0	RW	N	RESERVED	RESERVED
	4	1	RW	N	RESERVED	RESERVED DS250DF230: 1 Other Devices: RESERVED, 0
	3	0	RW	N	MR_REFCLK_DET_DIS	0: CAL_CLK_IN detection and status reporting enabled (default) 1: CAL_CLK_IN detection disabled
	2	0	RW	N	RESERVED	RESERVED
	1	0	RW	N	RESERVED	RESERVED
	0	0	RW	N	RESERVED	RESERVED
0C	7:0	0	RW	N	RESERVED	RESERVED
0D	7:0	0	R	N	RESERVED	RESERVED

表 8-9. Shared Registers (continued)

ADDRESS (HEX)	BITS	DEFAULT VALUE (HEX)	MODE	EEPROM	FIELD NAME	DESCRIPTION
0E	7:2	0	RW	N	RESERVED	RESERVED
	1:0	0	R	N	RESERVED	RESERVED
0F	7:0	0	RW	N	RESERVED	RESERVED
10	7	1	RW	N	RESERVED	RESERVED
	6	1	RW	N	RESERVED	RESERVED
	5	1	RW	N	RESERVED	RESERVED
	4	1	RW	N	RESERVED	RESERVED
	3	1	RW	Y	RESERVED	RESERVED
	2	1	RW	Y	RESERVED	RESERVED
	1	1	RW	Y	RESERVED	RESERVED
	0	1	RW	Y	RESERVED	RESERVED
11	7	0	R	N	EECFG_CMPLT	11: Not valid
	6	0	R	N	EECFG_FAIL	10: EEPROM load completed successfully 01: EEPROM load failed after 64 attempts 00: EEPROM load in progress
	5	0	R	N	EECFG_ATMPT[5]	Number of attempts made to load EEPROM image
	4	0	R	N	EECFG_ATMPT[4]	
	3	0	R	N	EECFG_ATMPT[3]	
	2	0	R	N	EECFG_ATMPT[2]	
	1	0	R	N	EECFG_ATMPT[1]	
	0	0	R	N	EECFG_ATMPT[0]	
12	7	1	RW	N	REG_I2C_FAST	1: EEPROM load uses Fast I2C Mode (400 kHz) 0: EEPROM load uses Standard I2C Mode (100 kHz)
	6	0	RW	N	RESERVED	RESERVED
	5	0	RW	N	RESERVED	RESERVED
	4	1	RW	N	RESERVED	RESERVED
	3	0	RW	N	RESERVED	RESERVED
	2	0	RW	N	RESERVED	RESERVED
	1	0	RW	N	RESERVED	RESERVED
	0	1	RW	N	RESERVED	RESERVED

**表 8-10. Channel Registers, 0 to 39**

ADDRESS (HEX)	BITS	DEFAULT VALUE (HEX)	MODE	EEPROM	FIELD NAME	DESCRIPTION
00	7	0	RW	N	RESERVED	RESERVED
	6	0	RW	N	RESERVED	RESERVED
	5	0	RW	N	RESERVED	RESERVED
	4	0	RW	N	RESERVED	RESERVED
	3	0	RW	N	RST_CORE	1: Reset the 10M core clock domain. This is the main clock domain for all the state machines 0: Normal operation
	2	0	RW	N	RST_REGS	1: Reset channel registers to power-up defaults. 0: Normal operation
	1	0	RW	N	RST_VCO	1: Resets the CDR S2P clock domain, includes PPM counter, EOM counter. 0: Normal operation
	0	0	RW	N	RST_REFCLK	1: Resets the 25MHz reference clock domain, includes PPM counter. Does not work if 25MHz clock is not present. 0: Normal operation
01	7	0	R	N	SIGDET	Raw Signal Detect observation
	6	0	R	N	POL_INV_DET	Indicates PRBS checker detected polarity inversion in the locked data sequence.
	5	0	R	N	CDR_LOCK_LOSS_INT	1: Indicates loss of CDR lock after having acquired it. Bit clears on read. Feature must be enabled with Reg_0x31[1]
	4	0	R	N	PRBS_SEQ_DET[3]	Indicates the pattern detected on the input serial stream  0xxx: No detect 1000: 7 bits PRBS sequence 1001: 9 bits PRBS sequence 1010: 11 bits PRBS sequence 1011: 15 bits PRBS sequence 1100: 23 bits PRBS sequence 1101: 31 bits PRBS sequence 1110: 58 bits PRBS sequence 1111: 63 bits PRBS sequence
	3	0	R	N	PRBS_SEQ_DET[2]	
	2	0	R	N	PRBS_SEQ_DET[1]	
	1	0	R	N	PRBS_SEQ_DET[0]	
	0	0	R	N	SIG_DET_LOSS_INT	Loss of signal indicator, set once signal is acquired and then lost. Clears on read. Feature must be enabled with reg_31[0]

表 8-10. Channel Registers, 0 to 39 (continued)

ADDRESS (HEX)	BITS	DEFAULT VALUE (HEX)	MODE	EEPROM	FIELD NAME	DESCRIPTION
02	7	0	R	N	CDR_STATUS[7]	CDR Status [7:0]
	6	0	R	N	CDR_STATUS[6]	Bit[7] = PPM Count met
	5	0	R	N	CDR_STATUS[5]	<ul style="list-style-type: none"> <li>1: The data rate is within the specified PPM tolerance (typically around <math>\pm 1000</math> ppm unless specified otherwise in Reg 0x64).</li> <li>0: Error: PPM tolerance exceeded.</li> </ul>
	4	0	R	N	CDR_STATUS[4]	
	3	0	R	N	CDR_STATUS[3]	Bit[6] = Auto Adapt Complete <ul style="list-style-type: none"> <li>1: CTLE auto-adaption is complete.</li> <li>0: CTLE auto-adaption in progress.</li> </ul>
	2	0	R	N	CDR_STATUS[2]	
	1	0	R	N	CDR_STATUS[1]	Bit[5] = Fail Lock Check <ul style="list-style-type: none"> <li>1: Signal quality and amplitude level is not sufficient for lock.</li> <li>0: Signal quality and amplitude level is sufficient for CDR lock.</li> </ul>
	0	0	R	N	CDR_STATUS[0]	

**表 8-10. Channel Registers, 0 to 39 (continued)**

ADDRESS (HEX)	BITS	DEFAULT VALUE (HEX)	MODE	EEPROM	FIELD NAME	DESCRIPTION
03	7	0	RW	Y	EQ_BST0[1]	This register can be used to force an EQ boost setting if used in conjunction with channel Reg_0x2D[3].
	6	0	RW	Y	EQ_BST0[0]	
	5	0	RW	Y	EQ_BST1[1]	
	4	0	RW	Y	EQ_BST1[0]	
	3	0	RW	Y	EQ_BST2[1]	
	2	0	RW	Y	EQ_BST2[0]	
	1	0	RW	Y	EQ_BST3[1]	
	0	0	RW	Y	EQ_BST3[0]	
04	7	0	RW	N	RESERVED	RESERVED
	6	0	RW	N	RESERVED	RESERVED
	5	0	RW	N	RESERVED	RESERVED
	4	0	RW	N	RESERVED	RESERVED
	3	0	RW	N	RESERVED	RESERVED
	2	0	RW	N	RESERVED	RESERVED
	1	0	RW	N	RESERVED	RESERVED
	0	1	RW	N	RESERVED	RESERVED
05	7	0	RW	N	RESERVED	RESERVED
	6	0	RW	N	RESERVED	RESERVED
	5	0	RW	N	RESERVED	RESERVED
	4	0	RW	N	RESERVED	RESERVED
	3	0	RW	N	RESERVED	RESERVED
	2	0	RW	N	RESERVED	RESERVED
	1	0	RW	N	RESERVED	RESERVED
	0	1	RW	N	RESERVED	RESERVED
06	7	0	RW	N	RESERVED	RESERVED
	6	0	RW	N	RESERVED	RESERVED
	5	0	RW	N	RESERVED	RESERVED
	4	0	RW	N	RESERVED	RESERVED
	3	0	RW	N	RESERVED	RESERVED
	2	0	RW	N	RESERVED	RESERVED
	1	0	RW	N	RESERVED	RESERVED
	0	1	RW	N	RESERVED	RESERVED

表 8-10. Channel Registers, 0 to 39 (continued)

ADDRESS (HEX)	BITS	DEFAULT VALUE (HEX)	MODE	EEPROM	FIELD NAME	DESCRIPTION
07	7	0	RW	N	RESERVED	RESERVED
	6	0	RW	N	RESERVED	RESERVED
	5	0	RW	N	RESERVED	RESERVED
	4	0	RW	N	RESERVED	RESERVED
	3	0	RW	N	RESERVED	RESERVED
	2	0	RW	N	RESERVED	RESERVED
	1	0	RW	N	RESERVED	RESERVED
	0	1	RW	N	RESERVED	RESERVED
08	7	0	RW	Y	RESERVED	RESERVED
	6	1	RW	Y	RESERVED	RESERVED
	5	1	RW	Y	RESERVED	RESERVED
	4	1	RW	Y	RESERVED	RESERVED
	3	0	RW	Y	RESERVED	RESERVED
	2	0	RW	Y	RESERVED	RESERVED
	1	1	RW	Y	RESERVED	RESERVED
	0	1	RW	Y	RESERVED	RESERVED
09	7	0	RW	Y	REG_VCO_CAP_OV	Enable bit to override cap_cnt with value in Reg_0x0B[4:0]
	6	0	RW	Y	REG_SET_CP_LVL_LPF_OV	Enable bit to override lpf_dac_val with value in Reg_0x1F[4:0]
	5	0	RW	Y	REG_BYPASS_PFD_OV	0: Normal operation.
	4	0	RW	Y	REG_EN_FD_PD_VCO_PDIQ_OV	Enable bit to override en_fd, pd_pd, pd_vco, pd_pdiq with Reg_0x1E[0], Reg_0x1E[2], Reg_0x1C[0], Reg_0x1C[1]
	3	0	RW	Y	REG_EN_PD_CP_OV	Enable bit to override pd_fd_cp and pd_pd_cp with value in Reg_0x1B[1:0]
	2	0	RW	Y	REG_DIVSEL_OV	Enable bit to override divsel with value in Reg_0x18[6:4]
	1	0	RW	Y	RESERVED	RESERVED
	0	0	RW	Y	RESERVED	RESERVED

**表 8-10. Channel Registers, 0 to 39 (continued)**

ADDRESS (HEX)	BITS	DEFAULT VALUE (HEX)	MODE	EEPROM	FIELD NAME	DESCRIPTION
0A	7	0	RW	Y	RESERVED	RESERVED
	6	0	RW	Y	REG_EN_IDAC_PD_CP_OV_ AND_REG_EN_IDAC_FD_CP_OV	Enable bit to override phase detector charge pump settings with Reg_0x1C[7:5] Enable bit to override frequency detector charge pump settings with Reg_0x1C[4:2]
	5	0	RW	Y	REG_DAC_LPF_HIGH_PHASE_OV_ AND_REG_DAC_LPF_LOW_PHASE_OV	Enable bit to loop filter comparator trip voltages with Reg_0x16[7:0]
	4	0	RW	Y	RESERVED	RESERVED
	3	0	RW	N	REG_CDR_RESET_OV	Enable CDR Reset override with Reg_0x0A[2]
	2	0	RW	N	REG_CDR_RESET_SM	CDR Reset override bit
	1	0	RW	N	REG_CDR_LOCK_OV	Enable CDR lock signal override with Reg_0x0A[0]
	0	0	RW	N	REG_CDR_LOCK	CDR lock signal override bit
0B	7	0	RW	Y	RESERVED	RESERVED
	6	1	RW	Y	RESERVED	RESERVED
	5	1	RW	Y	RESERVED	RESERVED
	4	0	RW	Y	RESERVED	RESERVED
	3	0	RW	Y	RESERVED	RESERVED
	2	0	RW	Y	RESERVED	RESERVED
	1	1	RW	Y	RESERVED	RESERVED
	0	1	RW	Y	RESERVED	RESERVED
0C	7	0	RW	N	RESERVED	RESERVED
	6	0	RW	N	RESERVED	RESERVED
	5	0	RW	N	RESERVED	RESERVED
	4	0	RW	N	RESERVED	RESERVED
	3	0	RW	N	RESERVED	RESERVED
	2	0	RW	N	RESERVED	RESERVED
	1	0	RW	N	RESERVED	RESERVED
	0	0	RW	N	RESERVED	RESERVED

表 8-10. Channel Registers, 0 to 39 (continued)

ADDRESS (HEX)	BITS	DEFAULT VALUE (HEX)	MODE	EEPROM	FIELD NAME	DESCRIPTION
0D	7	1	RW	N	DES_PD	1: De-serializer (for PRBS checker) is powered down 0: De-serializer (for PRBS checker) is enabled
	6	0	RW	N	RESERVED	RESERVED
	5	0	RW	Y	RESERVED	RESERVED
	4	0	RW	Y	RESERVED	RESERVED
	3	0	RW	Y	RESERVED	RESERVED
	2	0	RW	Y	RESERVED	RESERVED
	1	0	RW	N	RESERVED	RESERVED
	0	0	RW	N	RAW_TX_SWING	DS250DF230 A1 Only: 0: Low Swing(Default) 1: High Swing, only when CDR is bypassed. Not Recommended when CDR is enabled
0E	7	1	RW	N	RESERVED	RESERVED
	6	0	RW	N	RESERVED	RESERVED
	5	0	RW	N	RESERVED	RESERVED
	4	1	RW	N	RESERVED	RESERVED
	3	0	RW	N	RESERVED	RESERVED
	2	0	RW	N	RESERVED	RESERVED
	1	1	RW	N	RESERVED	RESERVED
	0	1	RW	N	RESERVED	RESERVED
0F	7	0	RW	N	RESERVED	RESERVED
	6	1	RW	N	RESERVED	RESERVED
	5	1	RW	N	RESERVED	RESERVED
	4	0	RW	N	RESERVED	RESERVED
	3	1	RW	N	RESERVED	RESERVED
	2	0	RW	N	RESERVED	RESERVED
	1	0	RW	N	RESERVED	RESERVED
	0	1	RW	N	RESERVED	RESERVED
10	7	0	RW	N	RESERVED	RESERVED
	6	0	RW	N	RESERVED	RESERVED
	5	0	RW	N	RESERVED	RESERVED
	4	0	RW	N	RESERVED	RESERVED
	3	0	RW	N	RESERVED	RESERVED
	2	0	RW	N	RESERVED	RESERVED
	1	0	RW	N	RESERVED	RESERVED
	0	0	RW	N	RESERVED	RESERVED

**表 8-10. Channel Registers, 0 to 39 (continued)**

ADDRESS (HEX)	BITS	DEFAULT VALUE (HEX)	MODE	EEPROM	FIELD NAME	DESCRIPTION
11	7	0	RW	Y	EOM_SEL_VRANGE[1]	Manually set the EOM vertical range, used with channel Reg_0x2C[6]: 00: ±100 mV 01: ±200 mV 10: ±300 mV 11: ±400 mV
	6	0	RW	Y	EOM_SEL_VRANGE[0]	
	5	1	RW	Y	EOM_PD	1: Normal operation. Eye opening monitor (EOM) is automatically duty-cycled. 0: EOM is force-enabled
	4	0	RW	N	RESERVED	RESERVED
	3	0	RW	Y	DFE_TAP2_POL	Bit forces DFE tap 2 polarity 1: Negative, boosts by the specified tap weight 0: Positive, attenuates by the specified tap weight
	2	0	RW	Y	DFE_TAP3_POL	Bit forces DFE tap 3 polarity 1: Negative, boosts by the specified tap weight 0: Positive, attenuates by the specified tap weight
	1	0	RW	Y	DFE_TAP4_POL	Bit forces DFE tap 4 polarity 1: Negative, boosts by the specified tap weight 0: Positive, attenuates by the specified tap weight
	0	0	RW	Y	DFE_TAP5_POL	Bit forces DFE tap 5 polarity 1: Negative, boosts by the specified tap weight 0: Positive, attenuates by the specified tap weight
12	7	1	RW	Y	DFE_TAP1_POL	Bit forces DFE tap 1 polarity 1: Negative, boosts by the specified tap weight 0: Positive, attenuates by the specified tap weight
	6	0	RW	N	RESERVED	RESERVED
	5	0	RW	Y	RESERVED	RESERVED
	4	0	RW	Y	DFE_WT1[4]	These bits force DFE tap 1 weight. Manual DFE operation is required for this to take effect by setting Reg_0x15[7]=1. If Reg_0x15[7]=0, the value defined here is used as the initial DFE tap 1 weight during adaptation.
	3	0	RW	Y	DFE_WT1[3]	
	2	0	RW	Y	DFE_WT1[2]	
	1	1	RW	Y	DFE_WT1[1]	
	0	1	RW	Y	DFE_WT1[0]	

表 8-10. Channel Registers, 0 to 39 (continued)

ADDRESS (HEX)	BITS	DEFAULT VALUE (HEX)	MODE	EEPROM	FIELD NAME	DESCRIPTION
13	7	1	RW	N	EQ_PD_PEAKDETECT	1: Normal operation. Power down test mode. 0: Test mode.
	6	0	RW	Y	EQ_PD_SD	1: Power down signal detect. 0: Normal operation. Enable signal detect.
	5	1	RW	Y	EQ_HI_GAIN	1: Enable high DC gain mode in the equalizer 0: Enable low DC gain mode in the equalizer (Refer to the Programming Guide for more details)
	4	1	RW	Y	EQ_EN_DC_OFF	1: Normal operation. 0: Disable DC offset compensation.
	3	0	RW	Y	RESERVED	RESERVED
	2	0	RW	Y	EQ_LIMIT_EN	1: Configures the final stage of the equalizer to be a limiting stage. 0: Normal operation, final stage of the equalizer is configured to be a non-limiting stage.
	1	0	RW	Y	RESERVED	RESERVED
	0	0	RW	Y	RESERVED	RESERVED
14	7	0	RW	Y	EQ_SD_PRESET	1: Forces signal detect HIGH, and force enables the channel. Should not be set if bit 6 is set. 0: Normal Operation.
	6	0	RW	Y	EQ_SD_RESET	1: Forces signal detect LOW and force disables the channel. Should not be set if bit 7 is set. 0: Normal Operation.
	5	0	RW	Y	EQ_REFA_SEL1	Controls the signal detect assert levels. (Refer to the Programming Guide for more details)
	4	0	RW	Y	EQ_REFA_SEL0	
	3	0	RW	Y	EQ_REFD_SEL1	Controls the signal detect de-assert levels. (Refer to the Programming Guide for more details)
	2	1	RW	Y	EQ_REFD_SEL0	
	1	0	RW	N	RESERVED	RESERVED
	0	0	RW	N	RESERVED	RESERVED

**表 8-10. Channel Registers, 0 to 39 (continued)**

ADDRESS (HEX)	BITS	DEFAULT VALUE (HEX)	MODE	EEPROM	FIELD NAME	DESCRIPTION
15	7	0	RW	Y	DFE_FORCE_EN	1: Enables manual DFE tap settings 0: Normal operation
	6	0	RW	N	RESERVED	RESERVED
	5	0	RW	N	RESERVED	RESERVED
	4	1	RW	Y	RESERVED	RESERVED
	3	0	RW	Y	DRV_PD	1: Powers down the high speed driver 0: Normal operation
	2	0	RW	Y	RESERVED	DS250DF230 Alpha Version Only: EQ_EN_BYPASS: CTLE (EQ) stage 1-3 bypass 1: CTLE stages 1-3 are bypassed 0: CTLE stage 1-3 are not bypassed (default)
	1	0	RW	Y	RESERVED	RESERVED
	0	0	RW	Y	RESERVED	RESERVED
16	7	0	RW	Y	RESERVED	RESERVED
	6	1	RW	Y	RESERVED	RESERVED
	5	1	RW	Y	RESERVED	RESERVED
	4	1	RW	Y	RESERVED	RESERVED
	3	1	RW	Y	RESERVED	RESERVED
	2	0	RW	Y	RESERVED	RESERVED
	1	1	RW	Y	RESERVED	RESERVED
	0	0	RW	Y	RESERVED	RESERVED
17	7	0	RW	Y	RESERVED	RESERVED
	6	0	RW	Y	RESERVED	RESERVED
	5	1	RW	Y	RESERVED	RESERVED
	4	1	RW	Y	RESERVED	RESERVED
	3	0	RW	Y	RESERVED	RESERVED
	2	1	RW	Y	RESERVED	RESERVED
	1	1	RW	Y	RESERVED	RESERVED
	0	0	RW	Y	RESERVED	RESERVED

表 8-10. Channel Registers, 0 to 39 (continued)

ADDRESS (HEX)	BITS	DEFAULT VALUE (HEX)	MODE	EEPROM	FIELD NAME	DESCRIPTION
18	7	0	RW	N	RESERVED	RESERVED
	6	1	RW	Y	PDIQ_SEL_DIV[2]	These bits will force the divider setting if 0x09[2] is set. 000: Divide by 1 001: Divide by 2 010: Divide by 4 011: Divide by 8 100: Divide by 16 All other values are reserved.
	5	0	RW	Y	PDIQ_SEL_DIV[1]	
	4	0	RW	Y	PDIQ_SEL_DIV[0]	
	3	0	RW	N	RESERVED	RESERVED
	2	0	RW	Y	RESERVED	RESERVED
	1	0	RW	N	RESERVED	RESERVED
	0	0	RW	N	RESERVED	RESERVED
19	7	0	RW	N	RESERVED	RESERVED
	6	0	RW	N	RESERVED	RESERVED
	5	1	RW	Y	RESERVED	RESERVED
	4	0	RW	Y	RESERVED	RESERVED
	3	0	RW	Y	RESERVED	RESERVED
	2	0	RW	Y	RESERVED	RESERVED
	1	0	RW	Y	RESERVED	RESERVED
	0	0	RW	Y	RESERVED	RESERVED
1A	7	0	RW	Y	BG_SEL_RPH_LV[1]	RPH
	6	1	RW	Y	BG_SEL_RPH_LV[0]	RPH
	5	1	RW	Y	RESERVED	RESERVED
	4	0	RW	Y	RESERVED	RESERVED
	3	1	RW	Y	RESERVED	RESERVED
	2	0	RW	Y	RESERVED	DS250DF230: en_rclk_lv 1: Enable Recovered clock output on IO pin 0: Disable Recovered clock output on IO pin
	1	0	RW	N	RESERVED	RESERVED
	0	0	RW	N	RESERVED	RESERVED

**表 8-10. Channel Registers, 0 to 39 (continued)**

ADDRESS (HEX)	BITS	DEFAULT VALUE (HEX)	MODE	EEPROM	FIELD NAME	DESCRIPTION
1B	7	0	RW	N	RESERVED	RESERVED
	6	0	RW	N	RESERVED	RESERVED
	5	0	RW	N	RESERVED	RESERVED
	4	0	RW	N	RESERVED	RESERVED
	3	0	RW	N	RESERVED	RESERVED
	2	0	RW	N	RESERVED	RESERVED
	1	1	RW	Y	CP_EN_CP_PD	1: Normal operation, phase detector charge pump enabled
	0	1	RW	Y	CP_EN_CP_FD	1: Normal operation, frequency detector charge pump enabled
1C	7	1	RW	Y	EN_IDAC_PD_CP2	Phase detector charge pump setting. Override bit required for these bits to take effect
	6	0	RW	Y	EN_IDAC_PD_CP1	
	5	0	RW	Y	EN_IDAC_PD_CP0	
	4	1	RW	Y	EN_IDAC_FD_CP2	Frequency detector charge pump setting. Override bit required for these bits to take effect
	3	0	RW	Y	EN_IDAC_FD_CP1	
	2	0	RW	Y	EN_IDAC_FD_CP0	
	1	0	RW	Y	RESERVED	RESERVED
	0	0	RW	Y	RESERVED	RESERVED
1D	7	0	RW	N	RESERVED	RESERVED
	6	0	RW	N	RESERVED	RESERVED
	5	0	RW	N	RESERVED	RESERVED
	4	0	RW	N	RESERVED	RESERVED
	3	0	RW	N	RESERVED	RESERVED
	2	0	RW	N	RESERVED	RESERVED
	1	0	RW	N	RESERVED	RESERVED
	0	0	RW	N	RESERVED	RESERVED

表 8-10. Channel Registers, 0 to 39 (continued)

ADDRESS (HEX)	BITS	DEFAULT VALUE (HEX)	MODE	EEPROM	FIELD NAME	DESCRIPTION
1E	7	1	RW	Y	PFD_SEL_DATA_PRELCK[2]	Output mode for when the CDR is not locked. For these values to take effect, Reg_0x09[5] must be set to 0, which is the default. 000: Raw Data 111: Mute (Default) All other values are reserved. (Refer to the Programming Guide for more details)
	6	1	RW	Y	PFD_SEL_DATA_PRELCK[1]	
	5	1	RW	Y	PFD_SEL_DATA_PRELCK[0]	
	4	0	RW	N	SER_EN	1: Enable serializer (used for PRBS Generator) 0: Normal operation. Disable serializer.
	3	1	RW	Y	DFE_PD	This bit must be cleared for the DFE to be functional in any adapt mode. 1: (Default) DFE disabled. 0: DFE enabled
	2	0	RW	Y	PFD_PD_PD	1: Power down PFD phase detector. 0: Normal operation. Enable PFD phase detector.
	1	0	RW	Y	EN_PARTIAL_DFE	1: Enable DFE taps 3-5. DFE_PD must also be set to 0. 0: (Default) Disable DFE taps 3-5.
	0	1	RW	Y	PFD_EN_FD	1: Normal operation. Enable PFD frequency detector. 0: Disable PFD frequency detector.
1F	7	0	RW	N	RESERVED	RESERVED
	6	0	RW	N	RESERVED	RESERVED
	5	0	RW	N	RESERVED	RESERVED
	4	0	RW	Y	RESERVED	RESERVED
	3	1	RW	Y	MR_LPF_AUTO_ADJUST_EN	1: Normal operation. Allow LPF to tune to optimum value during fast-cap search routine. 0: Otherwise LPF value is determined by the Reg_0x9D.
	2	0	RW	Y	RESERVED	RESERVED
	1	1	RW	Y	RESERVED	RESERVED
	0	1	RW	Y	RESERVED	RESERVED

**表 8-10. Channel Registers, 0 to 39 (continued)**

ADDRESS (HEX)	BITS	DEFAULT VALUE (HEX)	MODE	EEPROM	FIELD NAME	DESCRIPTION	
20	7	0	RW	Y	DFE_WT5[3]	Bits force DFE tap 5 weight, manual DFE operation required to take effect by setting 0x15[7]=1.	
	6	0	RW	Y	DFE_WT5[2]		
	5	0	RW	Y	DFE_WT5[1]		
	4	0	RW	Y	DFE_WT5[0]		
	21	3	0	RW	Y	DFE_WT4[3]	Bits force DFE tap 4 weight, manual DFE operation required to take effect by setting 0x15[7]=1.
		2	0	RW	Y	DFE_WT4[2]	
		1	0	RW	Y	DFE_WT4[1]	
		0	0	RW	Y	DFE_WT4[0]	
21	7	0	RW	Y	DFE_WT3[3]	Bits force DFE tap 3 weight, manual DFE operation required to take effect by setting 0x15[7]=1.	
	6	0	RW	Y	DFE_WT3[2]		
	5	0	RW	Y	DFE_WT3[1]		
	4	0	RW	Y	DFE_WT3[0]		
	22	3	0	RW	Y	DFE_WT2[3]	Bits force DFE tap 2 weight, manual DFE operation required to take effect by setting 0x15[7]=1.
		2	0	RW	Y	DFE_WT2[2]	
		1	0	RW	Y	DFE_WT2[1]	
		0	0	RW	Y	DFE_WT2[0]	
22	7	0	RW	N	EOM_OV	1: Override enable for EOM manual control 0: Normal operation	
	6	0	RW	N	EOM_SEL_RATE_OV	1: Override enable for EOM rate selection 0: Normal operation	
	5	0	RW	N	RESERVED	RESERVED	
	4	0	RW	N	RESERVED	RESERVED	
	3	0	RW	N	RESERVED	RESERVED	
	2	0	RW	N	RESERVED	RESERVED	
	1	0	RW	N	RESERVED	RESERVED	
	0	0	RW	N	RESERVED	RESERVED	
23	7	0	RW	N	EOM_GET_HEO_VEO_OV	1: Override enable for manual control of the HEO/VEO trigger 0: Normal operation	
	6	1	RW	Y	DFE_OV	1: Normal operation; DFE must be enabled in Reg_0x1E[3].	
	5	0	RW	N	RESERVED	RESERVED	
	4	0	RW	N	RESERVED	RESERVED	
	3	0	RW	N	RESERVED	RESERVED	
	2	0	RW	N	RESERVED	RESERVED	
	1	0	RW	N	RESERVED	RESERVED	
	0	0	RW	N	RESERVED	RESERVED	

表 8-10. Channel Registers, 0 to 39 (continued)

ADDRESS (HEX)	BITS	DEFAULT VALUE (HEX)	MODE	EEPROM	FIELD NAME	DESCRIPTION
24	7	0	RW	N	FAST_EOM	1: Enables fast EOM for full eye capture. In this mode the phase DAC and voltage DAC or the EOM are automatically incremented through a 64 x 64 matrix. Values for each point are stored in Reg_0x25 and Reg_0x26. 0: Normal operation.
	6	0	R	N	DFE_EQ_ERROR_NO_LOCK	DFE/CTLE SM quit due to loss of lock
	5	0	R	N	GET_HEO_VEO_ERROR_NO_HITS	get_heo_veo sees no hits at zero crossing
	4	0	R	N	GET_HEO_VEO_ERROR_NO_OPENING	get_heo_veo cannot see a vertical eye opening
	3	0	RW	N	RESERVED	RESERVED
	2	0	RWSC	N	DFE_ADAPT	1: Manually start DFE adaption (self-clearing). 0: Normal operation.
	1	0	R	N	EOM_GET_HEO_VEO	1: Manually triggers HEO/VEO measurement; feature must be enabled with Reg_0x23[7]; the HEO/VEO values are read from Reg_0x27, Reg_0x28
	0	0	RWSC	N	EOM_START	1: Starts EOM counter, self-clearing
25	7	0	R	N	EOM_COUNT15	MSBs of EOM counter
	6	0	R	N	EOM_COUNT14	
	5	0	R	N	EOM_COUNT13	
	4	0	R	N	EOM_COUNT12	
	3	0	R	N	EOM_COUNT11	
	2	0	R	N	EOM_COUNT10	
	1	0	R	N	EOM_COUNT9	
	0	0	R	N	EOM_COUNT8	
26	7	0	R	N	EOM_COUNT7	LSBs of EOM counter
	6	0	R	N	EOM_COUNT6	
	5	0	R	N	EOM_COUNT5	
	4	0	R	N	EOM_COUNT4	
	3	0	R	N	EOM_COUNT3	
	2	0	R	N	EOM_COUNT2	
	1	0	R	N	EOM_COUNT1	
	0	0	R	N	EOM_COUNT0	

**表 8-10. Channel Registers, 0 to 39 (continued)**

ADDRESS (HEX)	BITS	DEFAULT VALUE (HEX)	MODE	EEPROM	FIELD NAME	DESCRIPTION
27	7	0	R	N	HEO7	HEO value, requires CDR to be locked for valid measurement
	6	0	R	N	HEO6	
	5	0	R	N	HEO5	
	4	0	R	N	HEO4	
	3	0	R	N	HEO3	
	2	0	R	N	HEO2	
	1	0	R	N	HEO1	
	0	0	R	N	HEO0	
28	7	0	R	N	VEO7	VEO value, requires CDR to be locked for valid measurement
	6	0	R	N	VEO6	
	5	0	R	N	VEO5	
	4	0	R	N	VEO4	
	3	0	R	N	VEO3	
	2	0	R	N	VEO2	
	1	0	R	N	VEO1	
	0	0	R	N	VEO0	
29	7	0	RW	N	RESERVED	RESERVED
	6	0	R	N	EOM_VRANGE_SETTING[1]	Read the currently set Eye Monitor Voltage Range: 11 - +/-400mV 10 - +/- 300mV 01 - +/- 200mV 00 - +/- 100mV"
	5	0	R	N	EOM_VRANGE_SETTING[0]	
	4	0	RW	N	RESERVED	RESERVED
	3	0	RW	N	RESERVED	RESERVED
	2	0	RW	N	RESERVED	RESERVED
	1	0	R	N	VEO[8]	VEO MSB value
	0	0	R	N	HEO[8]	HEO MSB value

表 8-10. Channel Registers, 0 to 39 (continued)

ADDRESS (HEX)	BITS	DEFAULT VALUE (HEX)	MODE	EEPROM	FIELD NAME	DESCRIPTION	
2A	7	0	RW	Y	EOM_TIMER_THR[3]	The value of EOM_TIMER_THR[7:4] controls the amount of time the Eye Monitor samples each point in the eye. (Refer to the Programming Guide for more details)	
	6	1	RW	Y	EOM_TIMER_THR[2]		
	5	0	RW	Y	EOM_TIMER_THR[1]		
	4	1	RW	Y	EOM_TIMER_THR[0]		
	3	1	RW	Y	VEO_MIN_REQ_HITS[3]	Whenever the Eye Monitor is used to measure HEO and VEO, the data is sampled for some number of bits, set by Reg_0x2A[7:4]. This register sets the number of hits within that sample size that is required before the EOM will indicate a hit has occurred. This filtering only affects the VEO measurement.	
	2	0	RW	Y	VEO_MIN_REQ_HITS[2]		
	1	1	RW	Y	VEO_MIN_REQ_HITS[1]		
	0	0	RW	Y	VEO_MIN_REQ_HITS[0]		
2B	7	0	RW	N	RESERVED	RESERVED	
	6	0	RW	N	RESERVED	RESERVED	
	5	0	RW	Y	RESERVED	RESERVED	
	4	0	RW	Y	RESERVED	RESERVED	
	3	1	RW	Y	EOM_MIN_REQ_HITS[3]	Whenever the Eye Monitor is used to measure HEO and VEO, the data is sampled for some number of bits, set by Reg_0x2A[7:4]. This register sets the number of hits within that sample size that is required before the EOM will indicate a hit has occurred. This filtering only affects the HEO measurement.	
	2	0	RW	Y	EOM_MIN_REQ_HITS[2]		
	1	1	RW	Y	EOM_MIN_REQ_HITS[1]		
	0	0	RW	Y	EOM_MIN_REQ_HITS[0]		
2C	7	1	RW	N	RELOAD_DFE_TAPS	Causes DFE taps to load from last adapted values	
	6	1	RW	Y	VEO_SCALE	1: Normal operation. Scale VEO based on EOM vrange.	
	5	1	RW	Y	DFE_SM_FOM1	This register defines the Figure of Merit used when adapting the DFE: 00: not valid 01: SM uses only HEO 10: SM uses only VEO 11: SM uses both HEO and VEO Additionally, if Reg_0x6E[6] is set to '1', the Alternate FOM is used. This bit takes precedence over DFE_SM_FOM	
	4	1	RW	Y	DFE_SM_FOM0		
	3	0	RW	Y	DFE_ADAPT_COUNTER[3]		DFE look-beyond count.
	2	1	RW	Y	DFE_ADAPT_COUNTER[2]		
	1	1	RW	Y	DFE_ADAPT_COUNTER[1]		
	0	0	RW	Y	DFE_ADAPT_COUNTER[0]		

**表 8-10. Channel Registers, 0 to 39 (continued)**

ADDRESS (HEX)	BITS	DEFAULT VALUE (HEX)	MODE	EEPROM	FIELD NAME	DESCRIPTION
2D	7	0	RW	Y	RESERVED	RESERVED
	6	0	RW	Y	RESERVED	RESERVED
	5	1	RW	Y	RESERVED	RESERVED
	4	1	RW	Y	RESERVED	RESERVED
	3	0	RW	Y	REG_EQ_BST_OV	1: Allow override control of the EQ setting by writing to Reg_0x03 0: Normal operation.
	2	0	RW	Y	RESERVED	DS250DF230: 1: Set CTLE bypass Enabled when REG_RQ_BST_OV=1 0: Normal operation.
	1	0	RW	Y	RESERVED	RESERVED
	0	0	RW	Y	RESERVED	RESERVED
2E	7	0	RW	N	RESERVED	RESERVED
	6	0	RW	N	RESERVED	RESERVED
	5	0	R	N	EQ_BST3_BIT2_TO_EQ	Read-back of eq_BST3[2] driving the EQ
	4	0	RW	N	RESERVED	RESERVED
	3	0	RW	N	RESERVED	RESERVED
	2	0	RW	N	PRBS_PATTERN_SEL[2]	MSB for the PRBS_PATTERN_SEL field. Lower bits are found on Reg_0x30[1:0]. Refer to the Reg_0x30 description on this table.
	1	0	RW	N	RESERVED	RESERVED
	0	0	RW	N	RESERVED	RESERVED

表 8-10. Channel Registers, 0 to 39 (continued)

ADDRESS (HEX)	BITS	DEFAULT VALUE (HEX)	MODE	EEPROM	FIELD NAME	DESCRIPTION
2F	7	0	RW	Y	RESERVED	RESERVED
	6	1	RW	Y	RATE[2]	Configure PPM register and divider for a standard data rate. (Refer to the Programming Guide for more details)
	5	0	RW	Y	RATE[1]	
	4	1	RW	Y	RATE[0]	
	3	0	RW	Y	INDEX_OV	If this bit is 1, then Reg_0x39 is to be used as 4-bit index to the [15:0] array of EQ settings. The EQ setting at that index is loaded to the EQ boost registers going to the analog and is used as the starting point for adaption.
	2	1	RW	Y	EN_PPM_CHECK	1: (Default) Enable the PPM to be used as a qualifier when performing Lock Detect 0: Remove the PPM check as a lock qualifier.
	1	0	RW	Y	RESERVED	DS250DF230: 1: Disable eq_bypass for first 4 indices 0: Enable eq_bypass for first 4 indices
	0	0	RWSC	N	CTLE_ADAPT	1: Re-starts CTLE adaptation, self-clearing

**表 8-10. Channel Registers, 0 to 39 (continued)**

ADDRESS (HEX)	BITS	DEFAULT VALUE (HEX)	MODE	EEPROM	FIELD NAME	DESCRIPTION
30	7	0	RW	N	FREEZE_PPM_CNT	1: Freeze the PPM counter to allow safe read asynchronously
	6	0	RW	Y	EQ_SEARCH_OV_EN	1: Enables the EQ 'search' bit to be forced by Reg_0x13[2]
	5	0	RW	N	EN_PATT_INV	1: Enable automatic pattern inversion of successive 16 bit words when using the "Fixed Pattern" generator option.
	4	0	RW	N	RELOAD_PRBS_CHKCR	1: Force reload of seed into PRBS checker LFSR without holding the checker in reset.
	3	0	RW	N	PRBS_EN_DIG_CLK	This bit enables the clock to operate the PRBS generator and/or the PRBS checker. Toggling this bit is the primary method to reset the PRBS pattern generator and PRBS checker.
	2	0	RW	N	PRBS_PROGPATT_EN	Enable a fixed data pattern output. Requires that serializer is enabled with Reg_0x1E[4]. PRBS generator and checker should be disabled, Reg_0x30[3]. The fixed data pattern is set by Reg_0x7C and Reg_0x97. Enable inversion of the pattern every 16 bits with Reg_0x30[5].
	1	0	RW	N	PRBS_PATTERN_SEL[1]	Selects the pattern output when using the PRBS generator. Requires the pattern generator to be configured properly. The MSB for the PRBS_PATTERN_SEL field is in Reg_0x2E[2]. Use Reg_0x30[3] to enable the PRBS generator. 000: 2 <sup>7</sup> -1 bits PRBS sequence 001: 2 <sup>9</sup> -1 bits PRBS sequence 010: 2 <sup>11</sup> -1 bits PRBS sequence 011: 2 <sup>15</sup> -1 bits PRBS sequence 100: 2 <sup>23</sup> -1 bits PRBS sequence 101: 2 <sup>31</sup> -1 bits PRBS sequence 110: 2 <sup>58</sup> -1 bits PRBS sequence 111: 2 <sup>63</sup> -1 bits PRBS sequence
	0	0	RW	N	PRBS_PATTERN_SEL[0]	

表 8-10. Channel Registers, 0 to 39 (continued)

ADDRESS (HEX)	BITS	DEFAULT VALUE (HEX)	MODE	EEPROM	FIELD NAME	DESCRIPTION
31	7	0	RW	N	PRBS_INT_EN	1: Enables interrupt for detection of PRBS errors. The PRBS checker must be properly configured for this feature to work.
	6	0	RW	Y	ADAPT_MODE[1]	00: no adaption
	5	1	RW	Y	ADAPT_MODE[0]	01: adapt CTLE only 10: adapt CTLE until optimal, then DFE, then CTLE again 11: adapt CTLE until lock, then DFE, then EQ until optimal Note: for ADAPT_MODE=2 or 3, the DFE must be enabled by setting Reg_0x1E[3]=0 and Reg_0x1E[1]=1. (Refer to the Programming Guide for more details)
	4	0	RW	Y	EQ_SM_FOM[1]	CTLE (EQ) adaption state machine figure of merit.
	3	0	RW	Y	EQ_SM_FOM[0]	00: (Default) SM uses both HEO and VEO 01: SM uses HEO only 10: SM uses VEO only 11: SM uses both HEO and VEO Additionally, if Reg_0x6E[7]=1, the Alternate FOM is used. Reg_0x6E[7] takes precedence over EQ_SM_FOM.
	2	0	RW	N	RESERVED	RESERVED
	1	0	RW	Y	CDR_LOCK_LOSS_INT_EN	Enable for CDR Lock Loss Interrupt. Observable in Reg_0x01[5]
	0	0	RW	Y	SIGNAL_DET_LOSS_INT_EN	Enable for Signal Detect Loss Interrupt. Observable in Reg_0x01[0]
32	7	0	RW	Y	HEO_INT_THRESH[3]	These bits set the threshold for the HEO and VEO interrupt. Each threshold bit represents 8 counts of HEO or VEO.
	6	0	RW	Y	HEO_INT_THRESH[2]	
	5	0	RW	Y	HEO_INT_THRESH[1]	
	4	1	RW	Y	HEO_INT_THRESH[0]	
	3	0	RW	Y	VEO_INT_THRESH[3]	
	2	0	RW	Y	VEO_INT_THRESH[2]	
	1	0	RW	Y	VEO_INT_THRESH[1]	
	0	1	RW	Y	VEO_INT_THRESH[0]	

**表 8-10. Channel Registers, 0 to 39 (continued)**

ADDRESS (HEX)	BITS	DEFAULT VALUE (HEX)	MODE	EEPROM	FIELD NAME	DESCRIPTION
33	7	1	RW	Y	HEO_THRESH[3]	In adapt mode 3, the register sets the minimum HEO and VEO required for CTLE adaption, before starting DFE adaption. This can be a max of 15.
	6	0	RW	Y	HEO_THRESH[2]	
	5	0	RW	Y	HEO_THRESH[1]	
	4	0	RW	Y	HEO_THRESH[0]	
	3	1	RW	Y	VEO_THRESH[3]	
	2	0	RW	Y	VEO_THRESH[2]	
	1	0	RW	Y	VEO_THRESH[1]	
	0	0	RW	Y	VEO_THRESH[0]	
34	7	0	R	N	PPM_ERR_RDY	1: Indicates that a PPM error count is read to be read from channel Reg_0x3B and Reg_0x3C
	6	0	RW	Y	LOW_POWER_MODE_DISABLE	By default, all blocks (except signal detect) power down after 100 ms after signal detect goes low. If set high, all blocks get powered on after the signal detect initially goes high.
	5	1	RW	Y	LOCK_COUNTER[1]	After achieving lock, the CDR continues to monitor the lock criteria. If the lock criteria fail, the lock is checked for a total of N number of times before declaring an out of lock condition, where N is set by this the value in these registers, with a max value of +3, for a total of 4. If during the N lock checks, lock is regained, then the lock condition is left HI, and the counter is reset back to zero.
	4	1	RW	Y	LOCK_COUNTER[0]	
	3	1	RW	Y	DFE_MAX_TAP2_5[3]	These four bits are used to set the maximum value by which DFE taps 2-5 are able to adapt with each subsequent adaptation. Same used for both polarities.
	2	1	RW	Y	DFE_MAX_TAP2_5[2]	
	1	1	RW	Y	DFE_MAX_TAP2_5[1]	
	0	1	RW	Y	DFE_MAX_TAP2_5[0]	

表 8-10. Channel Registers, 0 to 39 (continued)

ADDRESS (HEX)	BITS	DEFAULT VALUE (HEX)	MODE	EEPROM	FIELD NAME	DESCRIPTION
35	7	0	RW	Y	DATA_LOCK_PPM[1]	Modifies the value of the PPM delta tolerance from channel Reg_0x64: 00 - ppm_delta[7:0] =1 x ppm_delta[7:0] 01 - ppm_delta[7:0] =1 x ppm_delta[7:0] + ppm_delta[3:1] 10 - ppm_delta[7:0] =2 x ppm_delta[7:0] 11 - ppm_delta[7:0] =2 x ppm_delta[7:0] + ppm_delta[3:1]
	6	0	RW	Y	DATA_LOCK_PPM[0]	
	5	0	RW	N	GET_PPM_ERROR	Get PPM error from PPM_COUNT - clears when done. Normally updates continuously, but can be manually triggered with read value from Reg_0x3B and Reg_0x3C
	4	0	RW	Y	DFE_MAX_TAP1[4]	Limits DFE tap 1 maximum magnitude.
	3	1	RW	Y	DFE_MAX_TAP1[3]	
	2	1	RW	Y	DFE_MAX_TAP1[2]	
	1	1	RW	Y	DFE_MAX_TAP1[1]	
	0	1	RW	Y	DFE_MAX_TAP1[0]	
36	7	0	RW	N	RESERVED	RESERVED
	6	0	RW	Y	HEO_VEO_INT_EN	1: Enable HEO/VEO interrupt capability
	5	1	RW	Y	REF_MODE[1]	11: Normal Operation. Reference mode 3.
	4	1	RW	Y	REF_MODE[0]	
	3	0	RW	N	RESERVED	RESERVED
	2	0	RW	Y	RESERVED	RESERVED
	1	0	RW	N	RESERVED	RESERVED
	0	0	RW	N	RESERVED	RESERVED
37	7	0	R	N	CTLE_STATUS[7]	Feature is reserved for future use
	6	0	R	N	CTLE_STATUS[6]	
	5	0	R	N	CTLE_STATUS[5]	
	4	0	R	N	CTLE_STATUS[4]	
	3	0	R	N	CTLE_STATUS[3]	
	2	0	R	N	CTLE_STATUS[2]	
	1	0	R	N	CTLE_STATUS[1]	
	0	0	R	N	CTLE_STATUS[0]	

**表 8-10. Channel Registers, 0 to 39 (continued)**

ADDRESS (HEX)	BITS	DEFAULT VALUE (HEX)	MODE	EEPROM	FIELD NAME	DESCRIPTION
38	7	0	R	N	DFE_STATUS[7]	Feature is reserved for future use
	6	0	R	N	DFE_STATUS[6]	
	5	0	R	N	DFE_STATUS[5]	
	4	0	R	N	DFE_STATUS[4]	
	3	0	R	N	DFE_STATUS[3]	
	2	0	R	N	DFE_STATUS[2]	
	1	0	R	N	DFE_STATUS[1]	
	0	0	R	N	DFE_STATUS[0]	
39	7	0	RW	N	RESERVED	RESERVED
	6	1	RW	Y	MR_EOM_RATE[1]	With eom_ov = 1, these bits control the Eye Monitor Rate: 11: Use for full rate, fastest 10: Use for 1/2 Rate All other values are reserved
	5	1	RW	Y	MR_EOM_RATE[0]	
	4	0	RW	Y	RESERVED	RESERVED
	3	0	RW	Y	START_INDEX[3]	Start index for EQ adaptation
	2	0	RW	Y	START_INDEX[2]	
	1	0	RW	Y	START_INDEX[1]	
	0	0	RW	Y	START_INDEX[0]	

表 8-11. Channel Registers, 3A to A9

ADDRESS (Hex)	BITS	DEFAULT VALUE (Hex)	MODE	EEPROM	FIELD NAME	DESCRIPTION
3A	7	0	RW	Y	FIXED_EQ_BST0[1]	During adaptation, if the divider setting is >2, then a fixed EQ setting from this register will be used. However, if channel Reg_0x6F[7] is enabled, then an EQ adaptation will be performed instead
	6	0	RW	Y	FIXED_EQ_BST0[0]	
	5	0	RW	Y	FIXED_EQ_BST1[1]	
	4	0	RW	Y	FIXED_EQ_BST1[0]	
	3	0	RW	Y	FIXED_EQ_BST2[1]	
	2	0	RW	Y	FIXED_EQ_BST2[0]	
	1	0	RW	Y	FIXED_EQ_BST3[1]	
	0	0	RW	Y	FIXED_EQ_BST3[0]	
3B	7	0	R	N	PPM_COUNT[15]	PPM count MSB
	6	0	R	N	PPM_COUNT[14]	
	5	0	R	N	PPM_COUNT[13]	
	4	0	R	N	PPM_COUNT[12]	
	3	0	R	N	PPM_COUNT[11]	
	2	0	R	N	PPM_COUNT[10]	
	1	0	R	N	PPM_COUNT[9]	
	0	0	R	N	PPM_COUNT[8]	
3C	7	0	R	N	PPM_COUNT[7]	PPM count LSB
	6	0	R	N	PPM_COUNT[6]	
	5	0	R	N	PPM_COUNT[5]	
	4	0	R	N	PPM_COUNT[4]	
	3	0	R	N	PPM_COUNT[3]	
	2	0	R	N	PPM_COUNT[2]	
	1	0	R	N	PPM_COUNT[1]	
	0	0	R	N	PPM_COUNT[0]	
3D	7	0	RW	Y	EN_FIR_CURSOR	1: Enable Pre- and Post-cursor FIR 0: Disable Pre- and Post-cursor FIR (lower power)
	6	0	RW	Y	FIR_C0_SGN	Main-cursor sign bit 0: positive 1: negative
	5	0	RW	Y	DRV_SEL_LOW_RATE_LV	0: Default 1: Slow slew rate. Not recommended for divided-by-1 data rates
	4	1	RW	Y	FIR_C0[4]	Main-cursor magnitude (Refer to the Programming Guide for more details)
	3	1	RW	Y	FIR_C0[3]	
	2	0	RW	Y	FIR_C0[2]	
	1	1	RW	Y	FIR_C0[1]	
	0	0	RW	Y	FIR_C0[0]	

**表 8-11. Channel Registers, 3A to A9 (continued)**

ADDRESS (Hex)	BITS	DEFAULT VALUE (Hex)	MODE	EEPROM	FIELD NAME	DESCRIPTION
3E	7	0	RW	Y	FIR_PD_TX	
	6	1	RW	Y	FIR_CN1_SGN	Pre-cursor sign bit 1: negative 0: positive
	5	0	RW	Y	RESERVED	RESERVED
	4	0	RW	Y	RESERVED	RESERVED
	3	0	RW	Y	FIR_CN1[3]	Pre-cursor magnitude (Refer to the Programming Guide for more details)
	2	0	RW	Y	FIR_CN1[2]	
	1	0	RW	Y	FIR_CN1[1]	
	0	0	RW	Y	FIR_CN1[0]	
3F	7	0	RW	Y	RESERVED	RESERVED
	6	1	RW	Y	FIR_CP1_SGN	Post-cursor sign bit 1: negative 0: positive
	5	0	RW	Y	RESERVED	DS250DF230: rclk_sel_div_lv[1] Valid only inconjunction with mr_cipri_clk_div_sel_ov; Otherwise decoded from rate table Analog Div Digital Div 00: 30 11 01: 32 10 10: 36 11 11: 40 10
	4	0	RW	Y	RESERVED	DS250DF230: rclk_sel_div_lv[0], see more on MSB description
	3	0	RW	Y	FIR_CP1[3]	Post-cursor magnitude (Refer to the Programming Guide for more details)
	2	0	RW	Y	FIR_CP1[2]	
	1	0	RW	Y	FIR_CP1[1]	
0	0	RW	Y	FIR_CP1[0]		
40	7	0	RW	Y	EQ_ARRAY_INDEX_0_BST0[1]	DS250DF230: The first four indices use enable_byapss=1.
	6	0	RW	Y	EQ_ARRAY_INDEX_0_BST0[0]	
	5	0	RW	Y	EQ_ARRAY_INDEX_0_BST1[1]	
	4	0	RW	Y	EQ_ARRAY_INDEX_0_BST1[0]	
	3	0	RW	Y	EQ_ARRAY_INDEX_0_BST2[1]	
	2	0	RW	Y	EQ_ARRAY_INDEX_0_BST2[0]	
	1	0	RW	Y	EQ_ARRAY_INDEX_0_BST3[1]	
	0	0	RW	Y	EQ_ARRAY_INDEX_0_BST3[0]	DS250DF230: Reg_0x40=0x00

表 8-11. Channel Registers, 3A to A9 (continued)

ADDRESS (Hex)	BITS	DEFAULT VALUE (Hex)	MODE	EEPROM	FIELD NAME	DESCRIPTION
41	7	0	RW	Y	EQ_ARRAY_INDEX_1_BST0[1]	
	6	0	RW	Y	EQ_ARRAY_INDEX_1_BST0[0]	
	5	0	RW	Y	EQ_ARRAY_INDEX_1_BST1[1]	
	4	0	RW	Y	EQ_ARRAY_INDEX_1_BST1[0]	
	3	0	RW	Y	EQ_ARRAY_INDEX_1_BST2[1]	
	2	0	RW	Y	EQ_ARRAY_INDEX_1_BST2[0]	
	1	0	RW	Y	EQ_ARRAY_INDEX_1_BST3[1]	
	0	1	RW	Y	EQ_ARRAY_INDEX_1_BST3[0]	DS250DF230: Reg_0x41=0x01
42	7	0	RW	Y	EQ_ARRAY_INDEX_2_BST0[1]	
	6	0	RW	Y	EQ_ARRAY_INDEX_2_BST0[0]	
	5	0	RW	Y	EQ_ARRAY_INDEX_2_BST1[1]	
	4	0	RW	Y	EQ_ARRAY_INDEX_2_BST1[0]	
	3	0	RW	Y	EQ_ARRAY_INDEX_2_BST2[1]	
	2	0	RW	Y	EQ_ARRAY_INDEX_2_BST2[0]	
	1	1	RW	Y	EQ_ARRAY_INDEX_2_BST3[1]	
	0	0	RW	Y	EQ_ARRAY_INDEX_2_BST3[0]	DS250DF230: Reg_0x42=0x02
43	7	0	RW	Y	EQ_ARRAY_INDEX_3_BST0[1]	
	6	0	RW	Y	EQ_ARRAY_INDEX_3_BST0[0]	
	5	0	RW	Y	EQ_ARRAY_INDEX_3_BST1[1]	
	4	0	RW	Y	EQ_ARRAY_INDEX_3_BST1[0]	
	3	0	RW	Y	EQ_ARRAY_INDEX_3_BST2[1]	
	2	0	RW	Y	EQ_ARRAY_INDEX_3_BST2[0]	
	1	1	RW	Y	EQ_ARRAY_INDEX_3_BST3[1]	
	0	1	RW	Y	EQ_ARRAY_INDEX_3_BST3[0]	DS250DF230: Reg_0x43=0x03
44	7	0	RW	Y	EQ_ARRAY_INDEX_4_BST0[1]	
	6	0	RW	Y	EQ_ARRAY_INDEX_4_BST0[0]	
	5	0	RW	Y	EQ_ARRAY_INDEX_4_BST1[1]	
	4	0	RW	Y	EQ_ARRAY_INDEX_4_BST1[0]	
	3	0	RW	Y	EQ_ARRAY_INDEX_4_BST2[1]	
	2	0	RW	Y	EQ_ARRAY_INDEX_4_BST2[0]	
	1	0	RW	Y	EQ_ARRAY_INDEX_4_BST3[1]	
	0	0	RW	Y	EQ_ARRAY_INDEX_4_BST3[0]	DS250DF230: Reg_0x44=0x00

**表 8-11. Channel Registers, 3A to A9 (continued)**

ADDRESS (Hex)	BITS	DEFAULT VALUE (Hex)	MODE	EEPROM	FIELD NAME	DESCRIPTION
45	7	0	RW	Y	EQ_ARRAY_INDEX_5_BST0[1]	
	6	1	RW	Y	EQ_ARRAY_INDEX_5_BST0[0]	
	5	0	RW	Y	EQ_ARRAY_INDEX_5_BST1[1]	
	4	0	RW	Y	EQ_ARRAY_INDEX_5_BST1[0]	
	3	0	RW	Y	EQ_ARRAY_INDEX_5_BST2[1]	
	2	0	RW	Y	EQ_ARRAY_INDEX_5_BST2[0]	
	1	0	RW	Y	EQ_ARRAY_INDEX_5_BST3[1]	
	0	0	RW	Y	EQ_ARRAY_INDEX_5_BST3[0]	
46	7	0	RW	Y	EQ_ARRAY_INDEX_6_BST0[1]	DS250DF230: Reg_0x45=0x40
	6	1	RW	Y	EQ_ARRAY_INDEX_6_BST0[0]	
	5	0	RW	Y	EQ_ARRAY_INDEX_6_BST1[1]	
	4	1	RW	Y	EQ_ARRAY_INDEX_6_BST1[0]	
	3	0	RW	Y	EQ_ARRAY_INDEX_6_BST2[1]	
	2	0	RW	Y	EQ_ARRAY_INDEX_6_BST2[0]	
	1	0	RW	Y	EQ_ARRAY_INDEX_6_BST3[1]	
	0	0	RW	Y	EQ_ARRAY_INDEX_6_BST3[0]	DS250DF230: Reg_0x46=0x50
47	7	1	RW	Y	EQ_ARRAY_INDEX_7_BST0[1]	
	6	0	RW	Y	EQ_ARRAY_INDEX_7_BST0[0]	
	5	0	RW	Y	EQ_ARRAY_INDEX_7_BST1[1]	
	4	0	RW	Y	EQ_ARRAY_INDEX_7_BST1[0]	
	3	0	RW	Y	EQ_ARRAY_INDEX_7_BST2[1]	
	2	0	RW	Y	EQ_ARRAY_INDEX_7_BST2[0]	
	1	0	RW	Y	EQ_ARRAY_INDEX_7_BST3[1]	
	0	0	RW	Y	EQ_ARRAY_INDEX_7_BST3[0]	DS250DF230: Reg_0x47=0x80
48	7	1	RW	Y	EQ_ARRAY_INDEX_8_BST0[1]	
	6	0	RW	Y	EQ_ARRAY_INDEX_8_BST0[0]	
	5	0	RW	Y	EQ_ARRAY_INDEX_8_BST1[1]	
	4	1	RW	Y	EQ_ARRAY_INDEX_8_BST1[0]	
	3	0	RW	Y	EQ_ARRAY_INDEX_8_BST2[1]	
	2	0	RW	Y	EQ_ARRAY_INDEX_8_BST2[0]	
	1	0	RW	Y	EQ_ARRAY_INDEX_8_BST3[1]	
	0	0	RW	Y	EQ_ARRAY_INDEX_8_BST3[0]	DS250DF230: Reg_0x48=0x90

表 8-11. Channel Registers, 3A to A9 (continued)

ADDRESS (Hex)	BITS	DEFAULT VALUE (Hex)	MODE	EEPROM	FIELD NAME	DESCRIPTION
49	7	1	RW	Y	EQ_ARRAY_INDEX_9_BST0[1]	
	6	1	RW	Y	EQ_ARRAY_INDEX_9_BST0[0]	
	5	0	RW	Y	EQ_ARRAY_INDEX_9_BST1[1]	
	4	0	RW	Y	EQ_ARRAY_INDEX_9_BST1[0]	
	3	0	RW	Y	EQ_ARRAY_INDEX_9_BST2[1]	
	2	0	RW	Y	EQ_ARRAY_INDEX_9_BST2[0]	
	1	0	RW	Y	EQ_ARRAY_INDEX_9_BST3[1]	
	0	0	RW	Y	EQ_ARRAY_INDEX_9_BST3[0]	DS250DF230: Reg_0x49=0xC0
4A	7	1	RW	Y	EQ_ARRAY_INDEX_10_BST0[1]	
	6	1	RW	Y	EQ_ARRAY_INDEX_10_BST0[0]	
	5	0	RW	Y	EQ_ARRAY_INDEX_10_BST1[1]	
	4	1	RW	Y	EQ_ARRAY_INDEX_10_BST1[0]	
	3	0	RW	Y	EQ_ARRAY_INDEX_10_BST2[1]	
	2	0	RW	Y	EQ_ARRAY_INDEX_10_BST2[0]	
	1	0	RW	Y	EQ_ARRAY_INDEX_10_BST3[1]	
	0	0	RW	Y	EQ_ARRAY_INDEX_10_BST3[0]	DS250DF230: Reg_0x4A=0xD0
4B	7	1	RW	Y	EQ_ARRAY_INDEX_11_BST0[1]	
	6	1	RW	Y	EQ_ARRAY_INDEX_11_BST0[0]	
	5	0	RW	Y	EQ_ARRAY_INDEX_11_BST1[1]	
	4	1	RW	Y	EQ_ARRAY_INDEX_11_BST1[0]	
	3	0	RW	Y	EQ_ARRAY_INDEX_11_BST2[1]	
	2	0	RW	Y	EQ_ARRAY_INDEX_11_BST2[0]	
	1	0	RW	Y	EQ_ARRAY_INDEX_11_BST3[1]	
	0	1	RW	Y	EQ_ARRAY_INDEX_11_BST3[0]	DS250DF230: Reg_0x4B=0xD1
4C	7	1	RW	Y	EQ_ARRAY_INDEX_12_BST0[1]	
	6	1	RW	Y	EQ_ARRAY_INDEX_12_BST0[0]	
	5	0	RW	Y	EQ_ARRAY_INDEX_12_BST1[1]	
	4	1	RW	Y	EQ_ARRAY_INDEX_12_BST1[0]	
	3	0	RW	Y	EQ_ARRAY_INDEX_12_BST2[1]	
	2	1	RW	Y	EQ_ARRAY_INDEX_12_BST2[0]	
	1	0	RW	Y	EQ_ARRAY_INDEX_12_BST3[1]	
	0	1	RW	Y	EQ_ARRAY_INDEX_12_BST3[0]	DS250DF230: Reg_0x4C=0xD5

**表 8-11. Channel Registers, 3A to A9 (continued)**

ADDRESS (Hex)	BITS	DEFAULT VALUE (Hex)	MODE	EEPROM	FIELD NAME	DESCRIPTION
4D	7	1	RW	Y	EQ_ARRAY_INDEX_13_BST0[1]	
	6	1	RW	Y	EQ_ARRAY_INDEX_13_BST0[0]	
	5	0	RW	Y	EQ_ARRAY_INDEX_13_BST1[1]	
	4	1	RW	Y	EQ_ARRAY_INDEX_13_BST1[0]	
	3	1	RW	Y	EQ_ARRAY_INDEX_13_BST2[1]	
	2	0	RW	Y	EQ_ARRAY_INDEX_13_BST2[0]	
	1	0	RW	Y	EQ_ARRAY_INDEX_13_BST3[1]	
	0	0	RW	Y	EQ_ARRAY_INDEX_13_BST3[0]	DS250DF230: Reg_0x4D=0xD8
4E	7	1	RW	Y	EQ_ARRAY_INDEX_14_BST0[1]	
	6	1	RW	Y	EQ_ARRAY_INDEX_14_BST0[0]	
	5	1	RW	Y	EQ_ARRAY_INDEX_14_BST1[1]	
	4	0	RW	Y	EQ_ARRAY_INDEX_14_BST1[0]	
	3	1	RW	Y	EQ_ARRAY_INDEX_14_BST2[1]	
	2	0	RW	Y	EQ_ARRAY_INDEX_14_BST2[0]	
	1	1	RW	Y	EQ_ARRAY_INDEX_14_BST3[1]	
	0	0	RW	Y	EQ_ARRAY_INDEX_14_BST3[0]	DS250DF230: Reg_0x4E=0xEA
4F	7	1	RW	Y	EQ_ARRAY_INDEX_15_BST0[1]	
	6	1	RW	Y	EQ_ARRAY_INDEX_15_BST0[0]	
	5	1	RW	Y	EQ_ARRAY_INDEX_15_BST1[1]	
	4	1	RW	Y	EQ_ARRAY_INDEX_15_BST1[0]	
	3	0	RW	Y	EQ_ARRAY_INDEX_15_BST2[1]	
	2	1	RW	Y	EQ_ARRAY_INDEX_15_BST2[0]	
	1	1	RW	Y	EQ_ARRAY_INDEX_15_BST3[1]	
	0	1	RW	Y	EQ_ARRAY_INDEX_15_BST3[0]	DS250DF230: Reg_0x4F=0xF7
50	7	1	RW	N	RESERVED	RESERVED
	6	1	RW	N	RESERVED	RESERVED
	5	1	RW	N	RESERVED	RESERVED
	4	1	RW	N	RESERVED	RESERVED
	3	1	RW	N	RESERVED	RESERVED
	2	1	RW	N	RESERVED	RESERVED
	1	0	RW	N	RESERVED	RESERVED
	0	1	RW	N	RESERVED	DS250DF230: Reg_0x50=0xFD

表 8-11. Channel Registers, 3A to A9 (continued)

ADDRESS (Hex)	BITS	DEFAULT VALUE (Hex)	MODE	EEPROM	FIELD NAME	DESCRIPTION
51	7	1	RW	N	RESERVED	RESERVED
	6	1	RW	N	RESERVED	RESERVED
	5	1	RW	N	RESERVED	RESERVED
	4	0	RW	N	RESERVED	RESERVED
	3	1	RW	N	RESERVED	RESERVED
	2	1	RW	N	RESERVED	RESERVED
	1	1	RW	N	RESERVED	RESERVED
	0	0	RW	N	RESERVED	DS250DF230: Reg_0x51=0xEE
52	7	1	RW	N	RESERVED	RESERVED
	6	1	RW	N	RESERVED	RESERVED
	5	1	RW	N	RESERVED	RESERVED
	4	0	RW	N	RESERVED	RESERVED
	3	1	RW	N	RESERVED	RESERVED
	2	1	RW	N	RESERVED	RESERVED
	1	1	RW	N	RESERVED	RESERVED
	0	1	RW	N	RESERVED	DS250DF230: Reg_0x52=0xEF
53	7	1	RW	N	RESERVED	RESERVED
	6	1	RW	N	RESERVED	RESERVED
	5	1	RW	N	RESERVED	RESERVED
	4	1	RW	N	RESERVED	RESERVED
	3	1	RW	N	RESERVED	RESERVED
	2	1	RW	N	RESERVED	RESERVED
	1	1	RW	N	RESERVED	RESERVED
	0	1	RW	N	RESERVED	DS250DF230: Reg_0x53=0xFF
54	7	0	RW	N	RESERVED	RESERVED
	6	0	RW	N	RESERVED	RESERVED
	5	0	RW	N	RESERVED	RESERVED
	4	0	RW	N	RESERVED	RESERVED
	3	0	RW	N	RESERVED	RESERVED
	2	0	RW	N	RESERVED	RESERVED
	1	0	RW	N	RESERVED	RESERVED
	0	0	RW	N	RESERVED	DS250DF230: Reg_0x54=0x00

**表 8-11. Channel Registers, 3A to A9 (continued)**

ADDRESS (Hex)	BITS	DEFAULT VALUE (Hex)	MODE	EEPROM	FIELD NAME	DESCRIPTION
55	7	0	RW	N	RESERVED	RESERVED
	6	0	RW	N	RESERVED	RESERVED
	5	0	RW	N	RESERVED	RESERVED
	4	0	RW	N	RESERVED	RESERVED
	3	0	RW	N	RESERVED	RESERVED
	2	0	RW	N	RESERVED	RESERVED
	1	0	RW	N	RESERVED	RESERVED
	0	0	RW	N	RESERVED	DS250DF230: Reg_0x55=0x00
56	7	0	RW	N	RESERVED	RESERVED
	6	0	RW	N	RESERVED	RESERVED
	5	0	RW	N	RESERVED	RESERVED
	4	0	RW	N	RESERVED	RESERVED
	3	0	RW	N	RESERVED	RESERVED
	2	0	RW	N	RESERVED	RESERVED
	1	0	RW	N	RESERVED	RESERVED
	0	0	RW	N	RESERVED	DS250DF230: Reg_0x56=0x00
57	7	0	RW	N	RESERVED	RESERVED
	6	0	RW	N	RESERVED	RESERVED
	5	0	RW	N	RESERVED	RESERVED
	4	0	RW	N	RESERVED	RESERVED
	3	0	RW	N	RESERVED	RESERVED
	2	0	RW	N	RESERVED	RESERVED
	1	0	RW	N	RESERVED	RESERVED
	0	0	RW	N	RESERVED	DS250DF230: Reg_0x57=0x00
58	7	0	RW	N	RESERVED	RESERVED
	6	0	RW	N	RESERVED	RESERVED
	5	0	RW	N	RESERVED	RESERVED
	4	0	RW	N	RESERVED	RESERVED
	3	0	RW	N	RESERVED	RESERVED
	2	0	RW	N	RESERVED	RESERVED
	1	0	RW	N	RESERVED	RESERVED
	0	0	RW	N	RESERVED	DS250DF230: Reg_0x58=0x00

表 8-11. Channel Registers, 3A to A9 (continued)

ADDRESS (Hex)	BITS	DEFAULT VALUE (Hex)	MODE	EEPROM	FIELD NAME	DESCRIPTION
59	7	0	RW	N	RESERVED	RESERVED
	6	0	RW	N	RESERVED	RESERVED
	5	0	RW	N	RESERVED	RESERVED
	4	0	RW	N	RESERVED	RESERVED
	3	0	RW	N	RESERVED	RESERVED
	2	0	RW	N	RESERVED	RESERVED
	1	0	RW	N	RESERVED	RESERVED
	0	0	RW	N	RESERVED	DS250DF230: Reg_0x59=0x00
5A	7	0	RW	N	RESERVED	RESERVED
	6	0	RW	N	RESERVED	RESERVED
	5	0	RW	N	RESERVED	RESERVED
	4	0	RW	N	RESERVED	RESERVED
	3	0	RW	N	RESERVED	RESERVED
	2	0	RW	N	RESERVED	RESERVED
	1	0	RW	N	RESERVED	RESERVED
	0	0	RW	N	RESERVED	DS250DF230: Reg_0x5A=0x00
5B	7	0	RW	N	RESERVED	RESERVED
	6	0	RW	N	RESERVED	RESERVED
	5	0	RW	N	RESERVED	RESERVED
	4	0	RW	N	RESERVED	RESERVED
	3	0	RW	N	RESERVED	RESERVED
	2	0	RW	N	RESERVED	RESERVED
	1	0	RW	N	RESERVED	RESERVED
	0	0	RW	N	RESERVED	DS250DF230: Reg_0x5B=0x00
5C	7	0	RW	N	RESERVED	RESERVED
	6	0	RW	N	RESERVED	RESERVED
	5	0	RW	N	RESERVED	RESERVED
	4	0	RW	N	RESERVED	RESERVED
	3	0	RW	N	RESERVED	RESERVED
	2	0	RW	N	RESERVED	RESERVED
	1	0	RW	N	RESERVED	RESERVED
	0	0	RW	N	RESERVED	DS250DF230: Reg_0x5C=0x00

**表 8-11. Channel Registers, 3A to A9 (continued)**

ADDRESS (Hex)	BITS	DEFAULT VALUE (Hex)	MODE	EEPROM	FIELD NAME	DESCRIPTION
5D	7	0	RW	N	RESERVED	RESERVED
	6	0	RW	N	RESERVED	RESERVED
	5	0	RW	N	RESERVED	RESERVED
	4	0	RW	N	RESERVED	RESERVED
	3	0	RW	N	RESERVED	RESERVED
	2	0	RW	N	RESERVED	RESERVED
	1	0	RW	N	RESERVED	RESERVED
	0	0	RW	N	RESERVED	DS250DF230: Reg_0x5D=0x00
5E	7	0	RW	N	RESERVED	RESERVED
	6	0	RW	N	RESERVED	RESERVED
	5	0	RW	N	RESERVED	RESERVED
	4	0	RW	N	RESERVED	RESERVED
	3	0	RW	N	RESERVED	RESERVED
	2	0	RW	N	RESERVED	RESERVED
	1	0	RW	N	RESERVED	RESERVED
	0	0	RW	N	RESERVED	DS250DF230: Reg_0x5E=0x00
5F	7	0	RW	N	RESERVED	RESERVED
	6	0	RW	N	RESERVED	RESERVED
	5	0	RW	N	RESERVED	RESERVED
	4	0	RW	N	RESERVED	RESERVED
	3	0	RW	N	RESERVED	RESERVED
	2	0	RW	N	RESERVED	RESERVED
	1	0	RW	N	RESERVED	RESERVED
	0	0	RW	N	RESERVED	DS250DF230: Reg_0x5F=0x00
60	7	0	RW	Y	GRP0_OV_CNT[7]	Group 0 count LSB
	6	0	RW	Y	GRP0_OV_CNT[6]	
	5	0	RW	Y	GRP0_OV_CNT[5]	
	4	0	RW	Y	GRP0_OV_CNT[4]	
	3	0	RW	Y	GRP0_OV_CNT[3]	
	2	0	RW	Y	GRP0_OV_CNT[2]	
	1	0	RW	Y	GRP0_OV_CNT[1]	
	0	0	RW	Y	GRP0_OV_CNT[0]	

表 8-11. Channel Registers, 3A to A9 (continued)

ADDRESS (Hex)	BITS	DEFAULT VALUE (Hex)	MODE	EEPROM	FIELD NAME	DESCRIPTION
61	7	0	RW	Y	CNT_DLTA_OV_0	Override enable for group 0 manual data rate selection
	6	0	RW	Y	GRP0_OV_CNT[14]	Group 0 count MSB
	5	0	RW	Y	GRP0_OV_CNT[13]	
	4	0	RW	Y	GRP0_OV_CNT[12]	
	3	0	RW	Y	GRP0_OV_CNT[11]	
	2	0	RW	Y	GRP0_OV_CNT[10]	
	1	0	RW	Y	GRP0_OV_CNT[9]	
	0	0	RW	Y	GRP0_OV_CNT[8]	
62	7	0	RW	Y	GRP1_OV_CNT[7]	Group 1 count LSB
	6	0	RW	Y	GRP1_OV_CNT[6]	
	5	0	RW	Y	GRP1_OV_CNT[5]	
	4	0	RW	Y	GRP1_OV_CNT[4]	
	3	0	RW	Y	GRP1_OV_CNT[3]	
	2	0	RW	Y	GRP1_OV_CNT[2]	
	1	0	RW	Y	GRP1_OV_CNT[1]	
	0	0	RW	Y	GRP1_OV_CNT[0]	
63	7	0	RW	Y	CNT_DLTA_OV_1	Override enable for group 1 manual data rate selection
	6	0	RW	Y	GRP1_OV_CNT[14]	Group 1 count MSB
	5	0	RW	Y	GRP1_OV_CNT[13]	
	4	0	RW	Y	GRP1_OV_CNT[12]	
	3	0	RW	Y	GRP1_OV_CNT[11]	
	2	0	RW	Y	GRP1_OV_CNT[10]	
	1	0	RW	Y	GRP1_OV_CNT[9]	
	0	0	RW	Y	GRP1_OV_CNT[8]	
64	7	0	RW	Y	GRP0_OV_DLTA[3]	Sets the PPM delta tolerance for the PPM counter lock check for group 0. Must also program channel Reg_0x67[7].
	6	0	RW	Y	GRP0_OV_DLTA[2]	
	5	0	RW	Y	GRP0_OV_DLTA[1]	
	4	0	RW	Y	GRP0_OV_DLTA[0]	
	3	0	RW	Y	GRP1_OV_DLTA[3]	Sets the PPM delta tolerance for the PPM counter lock check for group 1. Must also program channel Reg_0x67[6].
	2	0	RW	Y	GRP1_OV_DLTA[2]	
	1	0	RW	Y	GRP1_OV_DLTA[1]	
	0	0	RW	Y	GRP1_OV_DLTA[0]	

**表 8-11. Channel Registers, 3A to A9 (continued)**

ADDRESS (Hex)	BITS	DEFAULT VALUE (Hex)	MODE	EEPROM	FIELD NAME	DESCRIPTION
65	7	0	RW	N	RESERVED	RESERVED
	6	0	RW	N	RESERVED	RESERVED
	5	0	RW	N	RESERVED	RESERVED
	4	0	RW	N	RESERVED	RESERVED
	3	0	RW	N	RESERVED	RESERVED
	2	0	RW	N	RESERVED	RESERVED
	1	0	RW	N	RESERVED	RESERVED
	0	0	RW	N	RESERVED	RESERVED
66	7	0	RW	N	RESERVED	RESERVED
	6	0	RW	N	RESERVED	RESERVED
	5	0	RW	N	RESERVED	RESERVED
	4	0	RW	N	RESERVED	RESERVED
	3	0	RW	N	RESERVED	RESERVED
	2	0	RW	N	RESERVED	RESERVED
	1	0	RW	N	RESERVED	RESERVED
	0	0	RW	N	RESERVED	RESERVED
67	7	0	RW	Y	GRP0_OV_DLTA[4]	
	6	0	RW	Y	GRP1_OV_DLTA[4]	
	5	1	RW	Y	HV_LOCKMON_EN	1: Enable periodic monitoring of HEO/VEO for lock qualification. 0: Disable periodic HEO/VEO monitoring for lock qualification.
	4	0	RW	N	RESERVED	RESERVED
	3	0	RW	N	RESERVED	RESERVED
	2	0	RW	N	RESERVED	RESERVED
	1	0	RW	N	RESERVED	RESERVED
	0	0	RW	N	RESERVED	RESERVED
68	7	0	RW	N	RESERVED	RESERVED
	6	0	RW	N	RESERVED	RESERVED
	5	0	RW	N	RESERVED	RESERVED
	4	0	RW	N	RESERVED	RESERVED
	3	0	RW	N	RESERVED	RESERVED
	2	0	RW	N	RESERVED	RESERVED
	1	0	RW	N	RESERVED	RESERVED
	0	0	RW	N	RESERVED	RESERVED

表 8-11. Channel Registers, 3A to A9 (continued)

ADDRESS (Hex)	BITS	DEFAULT VALUE (Hex)	MODE	EEPROM	FIELD NAME	DESCRIPTION
69	7	0	RW	N	RESERVED	RESERVED
	6	0	RW	N	RESERVED	RESERVED
	5	0	RW	N	RESERVED	RESERVED
	4	0	RW	N	RESERVED	RESERVED
	3	1	RW	Y	RESERVED	RESERVED
	2	0	RW	Y	RESERVED	RESERVED
	1	1	RW	Y	RESERVED	RESERVED
	0	0	RW	Y	RESERVED	RESERVED
6A	7	0	RW	Y	VEO_LCK_THRSH[3]	VEO threshold to meet before lock is established. The LSB step size is 4 counts of VEO.
	6	0	RW	Y	VEO_LCK_THRSH[2]	
	5	1	RW	Y	VEO_LCK_THRSH[1]	
	4	0	RW	Y	VEO_LCK_THRSH[0]	
	3	0	RW	Y	HEO_LCK_THRSH[3]	HEO threshold to meet before lock is established. The LSB step size is 4 counts of HEO.
	2	0	RW	Y	HEO_LCK_THRSH[2]	
	1	0	RW	Y	HEO_LCK_THRSH[1]	
	0	1	RW	Y	HEO_LCK_THRSH[0]	
6B	7	0	RW	Y	RESERVED	RESERVED
	6	1	RW	Y	FOM_A[6]	Alternate Figure of Merit variable A. Max value for this register is 128.
	5	0	RW	Y	FOM_A[5]	
	4	0	RW	Y	FOM_A[4]	
	3	0	RW	Y	FOM_A[3]	
	2	0	RW	Y	FOM_A[2]	
	1	0	RW	Y	FOM_A[1]	
	0	0	RW	Y	FOM_A[0]	
6C	7	0	RW	Y	FOM_B[7]	
	6	0	RW	Y	FOM_B[6]	
	5	0	RW	Y	FOM_B[5]	
	4	0	RW	Y	FOM_B[4]	
	3	0	RW	Y	FOM_B[3]	
	2	0	RW	Y	FOM_B[2]	
	1	0	RW	Y	FOM_B[1]	
	0	0	RW	Y	FOM_B[0]	

**表 8-11. Channel Registers, 3A to A9 (continued)**

ADDRESS (Hex)	BITS	DEFAULT VALUE (Hex)	MODE	EEPROM	FIELD NAME	DESCRIPTION
6D	7	0	RW	Y	FOM_C[7]	VEO adjustment for Alternate FoM, variable C
	6	0	RW	Y	FOM_C[6]	
	5	0	RW	Y	FOM_C[5]	
	4	0	RW	Y	FOM_C[4]	
	3	0	RW	Y	FOM_C[3]	
	2	0	RW	Y	FOM_C[2]	
	1	0	RW	Y	FOM_C[1]	
	0	0	RW	Y	FOM_C[0]	
6E	7	0	RW	Y	EN_NEW_FOM_CTLE	1: CTLE adaption state machine will use the alternate FoM $HEO\_ALT = (HEO-B)*A*2$ $VEO\_ALT = (VEO-C)*(1-A)*2$ The values of A,B,C are set in channel Reg_0x6B, 0x6C, and 0x6D. The value of A is equal to the register value divided by 128. The Alternate FoM = $(HEOB)*A*2 + (VEO-C)*(1-A)*2$
	6	0	RW	Y	EN_NEW_FOM_DFE	1: DFE adaption state machine will use the alternate FoM. $HEO\_ALT = (HEO-B)*A*2$ $VEO\_ALT = (VEO-C)*(1-A)*2$ The values of A,B,C are set in channel Reg_0x6B, 0x6C, and 0x6D. The value of A is equal to the register value divided by 128 The Alternate FoM = $(HEOB)*A*2 + (VEO-C)*(1-A)*2$
	5	0	RW	N	RESERVED	RESERVED
	4	0	RW	N	RESERVED	RESERVED
	3	0	RW	N	RESERVED	RESERVED
	2	0	RW	N	RESERVED	RESERVED
	1	0	RW	N	RESERVED	RESERVED
	0	0	RW	N	RESERVED	RESERVED

表 8-11. Channel Registers, 3A to A9 (continued)

ADDRESS (Hex)	BITS	DEFAULT VALUE (Hex)	MODE	EEPROM	FIELD NAME	DESCRIPTION
6F	7	0	RW	Y	MR_EN_LOW_DIVSEL_EQ	Normally, during adaptation, if the divider setting is >2, then a fixed EQ setting, from Reg_0x3A will be used. However, if Reg_0x6F[7]=1, then an EQ adaptation will be performed instead.
	6	0	RW	Y	RESERVED	RESERVED
	5	0	RW	Y	RESERVED	RESERVED
	4	0	RW	N	RESERVED	RESERVED
	3	0	RW	N	RESERVED	RESERVED
	2	0	RW	N	RESERVED	RESERVED
	1	0	RW	N	RESERVED	RESERVED
	0	0	RW	N	RESERVED	RESERVED
70	7	0	RW	N	RESERVED	RESERVED
	6	0	RW	N	RESERVED	RESERVED
	5	0	RW	N	RESERVED	RESERVED
	4	0	RW	N	RESERVED	RESERVED
	3	0	RW	Y	EQ_LB_CNT[3]	CTLE look-beyond count for adaptation
	2	1	RW	Y	EQ_LB_CNT[2]	
	1	0	RW	Y	EQ_LB_CNT[1]	
	0	1	RW	Y	EQ_LB_CNT[0]	
71	7	0	R	N	PRBS_INT	When enabled by Reg_0x31[7], goes HI if a PRBS stream is detected. Clears on reading. PRBS checker must be enabled with Reg_0x30[3]. Once cleared, if a PRBS error occurs, then the interrupt will again go HI. Clears on reading. If signal detect is lost, this is considered a PRBS error, and the interrupt will go HI. Clears on reading.
	6	0	R	N	RESERVED	RESERVED
	5	0	R	N	DFE_POL_1_OBS	DFE tap 1 polarity observation
	4	0	R	N	DFE_WT1_OBS[4]	DFE tap 1 weight observation
	3	0	R	N	DFE_WT1_OBS[3]	
	2	0	R	N	DFE_WT1_OBS[2]	
	1	0	R	N	DFE_WT1_OBS[1]	
	0	0	R	N	DFE_WT1_OBS[0]	

**表 8-11. Channel Registers, 3A to A9 (continued)**

ADDRESS (Hex)	BITS	DEFAULT VALUE (Hex)	MODE	EEPROM	FIELD NAME	DESCRIPTION
72	7	0	R	N	RESERVED	RESERVED
	6	0	R	N	RESERVED	RESERVED
	5	0	R	N	RESERVED	RESERVED
	4	0	R	N	DFE_POL_2_OBS	Primary observation point for DFE tap 2 polarity
	3	0	R	N	DFE_WT2_OBS[3]	Primary observation point for DFE tap 2 weight
	2	0	R	N	DFE_WT2_OBS[2]	
	1	0	R	N	DFE_WT2_OBS[1]	
	0	0	R	N	DFE_WT2_OBS[0]	
73	7	0	R	N	RESERVED	RESERVED
	6	0	R	N	RESERVED	RESERVED
	5	0	R	N	RESERVED	RESERVED
	4	0	R	N	DFE_POL_3_OBS	Primary observation point for DFE tap 3 polarity
	3	0	R	N	DFE_WT3_OBS[3]	Primary observation point for DFE tap 3 weight
	2	0	R	N	DFE_WT3_OBS[2]	
	1	0	R	N	DFE_WT3_OBS[1]	
	0	0	R	N	DFE_WT3_OBS[0]	
74	7	0	R	N	RESERVED	RESERVED
	6	0	R	N	RESERVED	RESERVED
	5	0	R	N	RESERVED	RESERVED
	4	0	R	N	DFE_POL_4_OBS	Primary observation point for DFE tap 4 polarity
	3	0	R	N	DFE_WT4_OBS[3]	Primary observation point for DFE tap 4 weight
	2	0	R	N	DFE_WT4_OBS[2]	
	1	0	R	N	DFE_WT4_OBS[1]	
	0	0	R	N	DFE_WT4_OBS[0]	
75	7	0	R	N	RESERVED	RESERVED
	6	0	R	N	RESERVED	RESERVED
	5	0	R	N	RESERVED	RESERVED
	4	0	R	N	DFE_POL_5_OBS	Primary observation point for DFE tap 5 polarity
	3	0	R	N	DFE_WT5_OBS[3]	Primary observation point for DFE tap 5 weight
	2	0	R	N	DFE_WT5_OBS[2]	
	1	0	R	N	DFE_WT5_OBS[1]	
	0	0	R	N	DFE_WT5_OBS[0]	

表 8-11. Channel Registers, 3A to A9 (continued)

ADDRESS (Hex)	BITS	DEFAULT VALUE (Hex)	MODE	EEPROM	FIELD NAME	DESCRIPTION	
76	7	0	RW	Y	POST_LOCK_VEO_THR[3]	VEO threshold after LOCK is established	
	6	0	RW	Y	POST_LOCK_VEO_THR[2]		
	5	1	RW	Y	POST_LOCK_VEO_THR[1]		
	4	0	RW	Y	POST_LOCK_VEO_THR[0]		
	77	3	0	RW	Y	POST_LOCK_HEO_THR[3]	HEO threshold after LOCK is established
		2	0	RW	Y	POST_LOCK_HEO_THR[2]	
		1	0	RW	Y	POST_LOCK_HEO_THR[1]	
		0	1	RW	Y	POST_LOCK_HEO_THR[0]	
77	7	0	RW	N	PRBS_GEN_POL_EN	1: Force polarity inversion on generated PRBS data	
	6	0	RW	Y	RESERVED	RESERVED	
	5	0	RW	Y	RESERVED	RESERVED	
	4	1	RW	Y	RESERVED	RESERVED	
	3	1	RW	Y	RESERVED	RESERVED	
	2	0	RW	Y	RESERVED	RESERVED	
	1	1	RW	Y	RESERVED	RESERVED	
	0	0	RW	N	RESERVED	RESERVED	

**表 8-11. Channel Registers, 3A to A9 (continued)**

ADDRESS (Hex)	BITS	DEFAULT VALUE (Hex)	MODE	EEPROM	FIELD NAME	DESCRIPTION
78	7	0	R	N	RESERVED	RESERVED
	6	0	R	N	RESERVED	RESERVED
	5	0	R	N	SD_STATUS	Primary observation point for signal detect status
	4	0	R	N	CDR_LOCK_STATUS	Primary observation point for CDR lock status
	3	0	R	N	CDR_LOCK_INT	Requires that channel Reg_0x79[1] be set. 1: Indicates CDR has achieved lock, lock goes from LOW to HIGH. This bit is cleared after reading. This bit will stay set until it has been cleared by reading.
	2	0	R	N	SD_INT	Requires that channel Reg_0x79[0] be set. 1: Indicates signal detect status has changed. This will trigger when signal detect goes from LOW to HIGH or HIGH to LOW. This bit is cleared after reading. This bit will stay set until it has been cleared by reading.
	1	0	R	N	EOM_VRANGE_LIMIT_ERROR	Goes high if GET_HEO_VEO indicates high during adaptation
	0	0	R	N	HEO_VEO_INT	Requires that channel Reg_0x36[6] be set. 1: Indicates that HEO/VEO dropped below the limits set in channel Reg_0x76 This bit is cleared after reading. This bit will stay set until it has been cleared by reading.
79	7	0	RW	N	RESERVED	RESERVED
	6	0	RW	N	PRBS_CHK_EN	1: Enable the PRBS checker. 0: Disable the PRBS checker
	5	0	RW	N	PRBS_GEN_EN	1: Enable the pattern generator 0: Disable the pattern generator
	4	1	RW	N	RESERVED	RESERVED
	3	0	RW	N	RESERVED	RESERVED
	2	0	RW	N	RESERVED	RESERVED
	1	0	RW	Y	CDR_LOCK_INT_EN	1: Enable CDR lock interrupt, observable in channel Reg_0x78[3] 0: Disable CDR lock interrupt
	0	0	RW	Y	SD_INT_EN	1: Enable signal detect interrupt, observable in channel Reg_0x78[3] 0: Disable signal detect interrupt

表 8-11. Channel Registers, 3A to A9 (continued)

ADDRESS (Hex)	BITS	DEFAULT VALUE (Hex)	MODE	EEPROM	FIELD NAME	DESCRIPTION
7A	7	0	RW	N	RESERVED	RESERVED
	6	0	RW	N	RESERVED	RESERVED
	5	0	RW	N	RESERVED	RESERVED
	4	0	RW	N	RESERVED	RESERVED
	3	0	RW	N	RESERVED	RESERVED
	2	0	RW	N	RESERVED	RESERVED
	1	0	RW	N	RESERVED	RESERVED
	0	0	RW	N	RESERVED	RESERVED
7B	7	0	RW	N	RESERVED	RESERVED
	6	0	RW	N	RESERVED	RESERVED
	5	0	RW	N	RESERVED	RESERVED
	4	0	RW	N	RESERVED	RESERVED
	3	0	RW	N	RESERVED	RESERVED
	2	0	RW	N	RESERVED	RESERVED
	1	0	RW	N	RESERVED	RESERVED
	0	0	RW	N	RESERVED	RESERVED
7C	7	0	R	N	PRBS_FIXED[7]	Pattern generator user defined pattern LSB. MSB located at channel Reg_0x97.
	6	0	R	N	PRBS_FIXED[6]	
	5	0	R	N	PRBS_FIXED[5]	
	4	0	R	N	PRBS_FIXED[4]	
	3	0	R	N	PRBS_FIXED[3]	
	2	0	R	N	PRBS_FIXED[2]	
	1	0	R	N	PRBS_FIXED[1]	
	0	0	R	N	PRBS_FIXED[0]	

**表 8-11. Channel Registers, 3A to A9 (continued)**

ADDRESS (Hex)	BITS	DEFAULT VALUE (Hex)	MODE	EEPROM	FIELD NAME	DESCRIPTION	
7D	7	0	RW	Y	CONT_ADAPT_HEO_CHNG_THRS[3]	Limit for HEO change before triggering a DFE adaption while continuous DFE adaption is enabled.	
	6	1	RW	Y	CONT_ADAPT_HEO_CHNG_THRS[2]		
	5	0	RW	Y	CONT_ADAPT_HEO_CHNG_THRS[1]		
	4	0	RW	Y	CONT_ADAPT_HEO_CHNG_THRS[0]		
	7E	3	1	RW	Y	CONT_ADAPT_VEO_CHNG_THRS[3]	Limit for VEO change before triggering a DFE adaption while continuous DFE adaption is enabled. (Refer to the Programming Guide for more details)
		2	0	RW	Y	CONT_ADAPT_VEO_CHNG_THRS[2]	
		1	0	RW	Y	CONT_ADAPT_VEO_CHNG_THRS[1]	
		0	0	RW	Y	CONT_ADAPT_VEO_CHNG_THRS[0]	
7E	7	0	RW	Y	CONT_ADPT_TAP_INCR[3]	Limit for allowable tap increase from the previous base point	
	6	0	RW	Y	CONT_ADPT_TAP_INCR[2]		
	5	0	RW	Y	CONT_ADPT_TAP_INCR[1]		
	4	1	RW	Y	CONT_ADPT_TAP_INCR[0]		
	3	0	RW	Y	RESERVED	RESERVED	
	2	0	RW	Y	RESERVED	RESERVED	
	1	1	RW	Y	RESERVED	RESERVED	
	0	1	RW	Y	RESERVED	RESERVED	

表 8-11. Channel Registers, 3A to A9 (continued)

ADDRESS (Hex)	BITS	DEFAULT VALUE (Hex)	MODE	EEPROM	FIELD NAME	DESCRIPTION
7F	7	0	RW	N	EN_OBS_ALT_FOM	1: Allows for alternate FoM calculation to be shown in channel registers Reg_0x27, Reg_0x28 and Reg_0x29 instead of HEO and VEO
	6	0	RW	N	RESERVED	RESERVED
	5	1	RW	Y	RESERVED	RESERVED
	4	0	RW	Y	EN_DFE_CONT_ADAPT	1: Continuous DFE adaption is enabled 0: DFE adapts only during lock and then freezes (Refer to the Programming Guide for more details)
	3	1	RW	Y	CONT_ADPT_CMP_BOTH	1: If continuous DFE adaption is enabled, a DFE adaption will trigger if either HEO or VEO degrades
	2	0	RW	Y	CONT_ADPT_COUNT[2]	Limit for number of weights the DFE can look ahead in continuous adaption. (Refer to the Programming Guide for more details)
	1	1	RW	Y	CONT_ADPT_COUNT[1]	
	0	0	RW	Y	CONT_ADPT_COUNT[0]	
80	7	0	R	N	RESERVED	RESERVED
	6	0	R	N	RESERVED	RESERVED
	5	0	R	N	RESERVED	RESERVED
	4	0	R	N	RESERVED	RESERVED
	3	0	R	N	RESERVED	RESERVED
	2	0	R	N	RESERVED	RESERVED
	1	0	R	N	RESERVED	RESERVED
	0	0	R	N	RESERVED	RESERVED
81	7	1	R	N	RESERVED	RESERVED
	6	1	R	N	RESERVED	RESERVED
	5	1	R	N	RESERVED	RESERVED
	4	0	R	N	RESERVED	RESERVED
	3	0	R	N	RESERVED	RESERVED
	2	1	R	N	RESERVED	RESERVED
	1	0	R	N	RESERVED	RESERVED
	0	0	R	N	RESERVED	RESERVED

**表 8-11. Channel Registers, 3A to A9 (continued)**

ADDRESS (Hex)	BITS	DEFAULT VALUE (Hex)	MODE	EEPROM	FIELD NAME	DESCRIPTION
82	7	0	RW	N	FREEZE_PRBS_CNTR	1: Freeze the PRBS error count to allow for readback. 0: Normal operation. Error counters is allowed to increment if the PRBS checker is properly configured
	6	0	RW	N	RST_PRBS_CNTR	1: Reset the PRBS error counter. 0: Normal operation. Error counter is released from reset.
	5	0	RW	N	PRBS_PATT_OV	1: Override PRBS pattern auto-detection. Forces the pattern checker to only lock onto the pattern defined in Reg_0x82[4:2]. 0: Normal operation. Pattern checker will automatically detect the PRBS pattern
	4	0	RW	N	PRBS_PATT[2]	Used with the PRBS checker. Usage is enabled with Reg_0x82[5]. Select PRBS pattern to be checked:
	3	0	RW	N	PRBS_PATT[1]	
	2	0	RW	N	PRBS_PATT[0]	
	1	0	RW	N	PRBS_POL_OV	1: Override PRBS pattern auto polarity detection. Forces the pattern checker to only lock onto the polarity defined in bit 0 of this register. 0: Normal operation, pattern checker will automatically detect the PRBS pattern polarity
	0	0	RW	N	PRBS_POL	Usage is enabled with Reg_0x82[1]=1 0: Forced polarity = true 1: Forced polarity = inverted
	83	7	0	R	N	RESERVED
6		0	R	N	RESERVED	RESERVED
5		0	R	N	RESERVED	RESERVED
4		0	R	N	RESERVED	RESERVED
3		0	R	N	RESERVED	RESERVED
2		0	R	N	PRBS_ERR_CNT[10]	PRBS checker error count
1		0	R	N	PRBS_ERR_CNT[9]	
0		0	R	N	PRBS_ERR_CNT[8]	

表 8-11. Channel Registers, 3A to A9 (continued)

ADDRESS (Hex)	BITS	DEFAULT VALUE (Hex)	MODE	EEPROM	FIELD NAME	DESCRIPTION
84	7	0	R	N	PRBS_ERR_CNT[7]	PRBS checker error count
	6	0	R	N	PRBS_ERR_CNT[6]	
	5	0	R	N	PRBS_ERR_CNT[5]	
	4	0	R	N	PRBS_ERR_CNT[4]	
	3	0	R	N	PRBS_ERR_CNT[3]	
	2	0	R	N	PRBS_ERR_CNT[2]	
	1	0	R	N	PRBS_ERR_CNT[1]	
	0	0	R	N	PRBS_ERR_CNT[0]	
85	7	0	R	N	RESERVED	RESERVED
	6	0	R	N	RESERVED	RESERVED
	5	0	R	N	RESERVED	RESERVED
	4	0	R	N	RESERVED	RESERVED
	3	0	R	N	RESERVED	RESERVED
	2	0	R	N	RESERVED	RESERVED
	1	0	R	N	RESERVED	RESERVED
	0	0	R	N	RESERVED	RESERVED
86	7	0	R	N	RESERVED	RESERVED
	6	0	R	N	RESERVED	RESERVED
	5	0	R	N	RESERVED	RESERVED
	4	0	R	N	RESERVED	RESERVED
	3	0	R	N	RESERVED	RESERVED
	2	0	R	N	RESERVED	RESERVED
	1	0	R	N	RESERVED	RESERVED
	0	0	R	N	RESERVED	RESERVED
87	7	0	R	N	RESERVED	RESERVED
	6	0	R	N	RESERVED	RESERVED
	5	0	R	N	RESERVED	RESERVED
	4	0	R	N	RESERVED	RESERVED
	3	0	R	N	RESERVED	RESERVED
	2	0	R	N	RESERVED	RESERVED
	1	0	R	N	RESERVED	RESERVED
	0	0	R	N	RESERVED	RESERVED

**表 8-11. Channel Registers, 3A to A9 (continued)**

ADDRESS (Hex)	BITS	DEFAULT VALUE (Hex)	MODE	EEPROM	FIELD NAME	DESCRIPTION
88	7	0	R	N	RESERVED	RESERVED
	6	0	R	N	RESERVED	RESERVED
	5	0	R	N	RESERVED	RESERVED
	4	0	R	N	RESERVED	RESERVED
	3	0	R	N	RESERVED	RESERVED
	2	0	R	N	RESERVED	RESERVED
	1	0	R	N	RESERVED	RESERVED
	0	0	R	N	RESERVED	RESERVED
89	7	0	R	N	RESERVED	RESERVED
	6	0	R	N	RESERVED	RESERVED
	5	0	R	N	RESERVED	RESERVED
	4	0	R	N	RESERVED	RESERVED
	3	0	R	N	RESERVED	RESERVED
	2	0	R	N	RESERVED	RESERVED
	1	0	R	N	RESERVED	RESERVED
	0	0	R	N	RESERVED	RESERVED
8A	7	0	R	N	RESERVED	RESERVED
	6	0	R	N	RESERVED	RESERVED
	5	0	R	N	RESERVED	RESERVED
	4	0	R	N	RESERVED	RESERVED
	3	0	R	N	RESERVED	RESERVED
	2	0	R	N	RESERVED	RESERVED
	1	0	R	N	RESERVED	RESERVED
	0	0	R	N	RESERVED	RESERVED
8B	7	0	RW	N	RESERVED	RESERVED
	6	0	RW	N	RESERVED	RESERVED
	5	0	RW	N	RESERVED	RESERVED
	4	0	RW	N	RESERVED	RESERVED
	3	0	RW	N	RESERVED	RESERVED
	2	0	RW	N	RESERVED	RESERVED
	1	0	RW	N	RESERVED	RESERVED
	0	0	RW	N	RESERVED	RESERVED

表 8-11. Channel Registers, 3A to A9 (continued)

ADDRESS (Hex)	BITS	DEFAULT VALUE (Hex)	MODE	EEPROM	FIELD NAME	DESCRIPTION
8C	7	0	RW	N	RESERVED	RESERVED
	6	0	RW	N	RESERVED	RESERVED
	5	0	RW	N	RESERVED	RESERVED
	4	0	RW	N	RESERVED	RESERVED
	3	0	RW	N	RESERVED	RESERVED
	2	0	RW	N	RESERVED	RESERVED
	1	0	RW	N	RESERVED	RESERVED
	0	0	RW	N	RESERVED	RESERVED
8D	7	0	RW	N	RESERVED	RESERVED
	6	0	RW	N	RESERVED	RESERVED
	5	0	RW	N	RESERVED	RESERVED
	4	0	RW	N	RESERVED	RESERVED
	3	0	RW	N	RESERVED	RESERVED
	2	0	RW	N	RESERVED	DS250DF230: RESERVED, 0
	1	1	RW	N	RESERVED	RESERVED
	0	0	RW	N	RESERVED	RESERVED
8E	7	0	RW	N	RESERVED	RESERVED
	6	0	RW	N	RESERVED	RESERVED
	5	0	RW	N	RESERVED	RESERVED
	4	0	RW	N	RESERVED	RESERVED
	3	0	RW	N	RESERVED	RESERVED
	2	0	RW	N	RESERVED	RESERVED
	1	0	RW	N	RESERVED	RESERVED
	0	0	RW	Y	VGA_SEL_GAIN	VGA selection bit : 1: VGA high-gain mode 0: VGA low-gain mode (Refer to the Programming Guide for more details)
8F	7	0	R	N	EQ_BST_TO_EQ[7]	Primary observation point for the EQ boost setting.
	6	0	R	N	EQ_BST_TO_EQ[6]	
	5	0	R	N	EQ_BST_TO_EQ[5]	
	4	0	R	N	EQ_BST_TO_EQ[4]	
	3	0	R	N	EQ_BST_TO_EQ[3]	
	2	0	R	N	EQ_BST_TO_EQ[2]	
	1	0	R	N	EQ_BST_TO_EQ[1]	
	0	0	R	N	EQ_BST_TO_EQ[0]	

**表 8-11. Channel Registers, 3A to A9 (continued)**

ADDRESS (Hex)	BITS	DEFAULT VALUE (Hex)	MODE	EEPROM	FIELD NAME	DESCRIPTION
90	7	0	RW	N	RESERVED	RESERVED
	6	0	RW	N	RESERVED	RESERVED
	5	0	RW	N	RESERVED	RESERVED
	4	0	RW	N	RESERVED	RESERVED
	3	0	RW	N	RESERVED	RESERVED
	2	0	RW	N	RESERVED	RESERVED
	1	0	RW	N	RESERVED	RESERVED
	0	0	RW	N	RESERVED	RESERVED
91	7	0	RW	N	RESERVED	RESERVED
	6	0	RW	N	RESERVED	RESERVED
	5	0	RW	N	RESERVED	RESERVED
	4	0	RW	N	RESERVED	RESERVED
	3	0	RW	N	RESERVED	RESERVED
	2	0	RW	N	RESERVED	RESERVED
	1	0	RW	N	RESERVED	RESERVED
	0	0	RW	N	RESERVED	RESERVED
92	7:0	0	RW	N	RESERVED	RESERVED
93	7:0	0	RW	N	RESERVED	RESERVED
94	7:0	0	RW	N	RESERVED	RESERVED
95	7	0	RW	N	SD_ENABLE	1: Force enable signal detect 0: Normal operation
	6	0	RW	N	SD_DISABLE	1: Force disable signal detect 0: Normal operation
	5	0	RW	N	DC_OFF_ENABLE	1: Force enable DC offset compensation 0: Normal operation
	4	0	RW	N	DC_OFF_DISABLE	1: Force disable DC offset compensation 0: Normal operation
	3	0	RW	N	EQ_ENABLE	DS250DF230: 0 1: Force enable the CTLE 0: Normal operation
	2	0	RW	N	EQ_DISABLE	1: Force disable the CTLE 0: Normal operation
	1	0	RW	N	RESERVED	RESERVED
	0	0	RW	N	RESERVED	RESERVED

表 8-11. Channel Registers, 3A to A9 (continued)

ADDRESS (Hex)	BITS	DEFAULT VALUE (Hex)	MODE	EEPROM	FIELD NAME	DESCRIPTION
96	7	0	RW	N	RESERVED	RESERVED
	6	0	RW	N	RESERVED	RESERVED
	5	0	RW	N	RESERVED	RESERVED
	4	0	RW	N	RESERVED	RESERVED
	3	1	RW	Y	EQ_EN_LOCAL	1: Enable the ebuf for the local output. Can be set independently of other controls. (Refer to the Programming Guide for more details)
	2	0	RW	Y	EQ_EN_FANOUT	1: Enable the ebuf for the fanout. Can be set independently of other controls. (Refer to the Programming Guide for more details)
	1	0	RW	Y	EQ_SEL_XPNT	1: Indicates to a channel where it is getting its data from. 0 indicates local. 1-indicates from the cross. (Refer to the Programming Guide for more details)
	0	0	RW	Y	XPNT_SLAVE	1: Indicates to a channel if it needs to wait for the other channel to complete its lock/adaptation. The need for this condition comes up when input of one channel is routed to the other channel or multiple channels. (Refer to the Programming Guide for more details)
97	7	0	R	N	PRBS_FIXED[15]	Pattern generator user defined pattern MSB. LSB located at channel Reg_0x7C.
	6	0	R	N	PRBS_FIXED[14]	
	5	0	R	N	PRBS_FIXED[13]	
	4	0	R	N	PRBS_FIXED[12]	
	3	0	R	N	PRBS_FIXED[11]	
	2	0	R	N	PRBS_FIXED[10]	
	1	0	R	N	PRBS_FIXED[9]	
	0	0	R	N	PRBS_FIXED[8]	
98	7:6	0	RW	N	RESERVED	RESERVED
	5:0	0	RW	Y	RESERVED	RESERVED

**表 8-11. Channel Registers, 3A to A9 (continued)**

ADDRESS (Hex)	BITS	DEFAULT VALUE (Hex)	MODE	EEPROM	FIELD NAME	DESCRIPTION
99	7	0	RW	Y	RESERVED	RESERVED
	6	0	RW	Y	RESERVED	RESERVED
	5	1	RW	Y	RESERVED	RESERVED
	4	1	RW	Y	RESERVED	RESERVED
	3	1	RW	Y	RESERVED	RESERVED
	2	1	RW	Y	RESERVED	RESERVED
	1	1	RW	Y	RESERVED	RESERVED
	0	1	RW	Y	RESERVED	RESERVED
9A	7	0	RW	Y	RESERVED	RESERVED
	6	0	RW	Y	RESERVED	RESERVED
	5	1	RW	Y	RESERVED	RESERVED
	4	1	RW	Y	RESERVED	RESERVED
	3	1	RW	Y	RESERVED	RESERVED
	2	1	RW	Y	RESERVED	RESERVED
	1	1	RW	Y	RESERVED	RESERVED
	0	1	RW	Y	RESERVED	RESERVED
9B	7	1	RW	Y	RESERVED	RESERVED
	6	1	RW	Y	RESERVED	RESERVED
	5	1	RW	Y	RESERVED	RESERVED
	4	0	RW	Y	RESERVED	RESERVED
	3	0	RW	Y	RESERVED	RESERVED
	2	0	RW	Y	RESERVED	RESERVED
	1	0	RW	N	RESERVED	RESERVED
	0	0	RW	N	RESERVED	RESERVED
9C	7	0	RW	N	RESERVED	RESERVED
	6	0	RW	N	RESERVED	RESERVED
	5	1	RW	Y	RESERVED	RESERVED
	4	0	RW	Y	RESERVED	RESERVED
	3	0	RW	Y	RESERVED	RESERVED
	2	1	RW	Y	RESERVED	RESERVED
	1	0	RW	Y	RESERVED	RESERVED
	0	0	RW	Y	RESERVED	RESERVED

表 8-11. Channel Registers, 3A to A9 (continued)

ADDRESS (Hex)	BITS	DEFAULT VALUE (Hex)	MODE	EEPROM	FIELD NAME	DESCRIPTION
9D	7	1	RW	N	RESERVED	RESERVED
	6	0	RW	N	RESERVED	RESERVED
	5	1	RW	N	RESERVED	RESERVED
	4	0	RW	N	RESERVED	RESERVED
	3	0	RW	Y	RESERVED	RESERVED
	2	1	RW	Y	RESERVED	RESERVED
	1	0	RW	Y	RESERVED	RESERVED
	0	1	RW	N	RESERVED	RESERVED
9E	7	0	RW	Y	CP_EN_IDAC_PD[2]	Phase detector charge pump setting, when override is enabled. See reg_0C for other bits.
	6	1	RW	Y	CP_EN_IDAC_PD[1]	
	5	0	RW	Y	CP_EN_IDAC_PD[0]	
	4	0	RW	Y	CP_EN_IDAC_FD[2]	Frequency detector charge pump setting, when override is enabled. See reg_0C for other bits.
	3	1	RW	Y	CP_EN_IDAC_FD[1]	
	2	0	RW	Y	CP_EN_IDAC_FD[0]	
	1	0	RW	N	RESERVED	RESERVED
	0	0	RW	N	RESERVED	RESERVED
9F	7:0	0	R	N	NOT USED	
A0	7:0	0	R	N	NOT USED	
A1	7:0	0	R	N	NOT USED	
A2	7:0	0	R	N	NOT USED	
A3	7:0	0	R	N	NOT USED	
A4	7:0	0	R	N	NOT USED	
A5	7	0	RW	Y	PFD_SEL_DATA_PSTLCK[2]	Output mode for when the CDR is in lock. For these values to take effect, Reg_0x09[5] must be set to 0, which is the default. 000: Raw Data 001: Retimed data (default) 100: PRBS Generator or Fixed Pattern Generator Data 101: 10M clock 111: Mute All other values are reserved. (Refer to the Programming Guide for more details)
	6	0	RW	Y	PFD_SEL_DATA_PSTLCK[1]	
	5	1	RW	Y	PFD_SEL_DATA_PSTLCK[0]	
	4	0	RW	N	RESERVED	RESERVED
	3	0	RW	N	RESERVED	RESERVED
	2	0	RW	N	RESERVED	RESERVED
	1	0	RW	N	RESERVED	RESERVED
	0	0	RW	N	RESERVED	RESERVED

**表 8-11. Channel Registers, 3A to A9 (continued)**

ADDRESS (Hex)	BITS	DEFAULT VALUE (Hex)	MODE	EEPROM	FIELD NAME	DESCRIPTION
A6	7	0	RW	N	INCR_HIST_TMR	Provides an option to increase EOM timer given by 0x2A[7:4] for histogram collection by +8 for selection values < 8
	6	1	RW	Y	EOM_TMR_ABRT_ON_HIT	Enables faster scan through the eye-matrix by moving on to the next matrix point as soon as hit is observed Note: This bit does not affect when slope measurement are in progress
	5	0	RW	Y	SLP_MIN_REQ_HITS[1]	Minimum required hit count for registering a hit during slope measurements.
	4	0	RW	Y	SLP_MIN_REQ_HITS[0]	
	3	0	RW	Y	LFT_SLP	0: allows slope measurement for the right side of the eye 1: allows slope measurement for the left side of the eye
	2	0	RW	Y	TOP_SLP	0: allows slope measurement for the bottom side of the eye 1: allows slope measurement for the top side of the eye
	1	1	RW	Y	DFE_BATHTUB_FOM	Enables slope-based bathtub FoM for DFE adaptation
	0	1	RW	Y	CTLE_BATHTUB_FOM	Enables slope-based bathtub FoM for CTLE adaptation
A7	7:0	0	R	N	RESERVED	RESERVED
A8	7:0	0	RW	N	RESERVED	RESERVED
A9	7:0	0	RW	Y	RESERVED	RESERVED
AC (DS250DF230 Only)	7	0	RW	N	MR_DIS_PRELCK_HV	Disable heo veo acquisition before lock
	6	1	RW	N	MR_LPF_SAR_ADJST_EN	Enables the use of temperature dependent LPF for Fastcap search
	5	0	RW	N	RESERVED	RESERVED
	4	1	RW	N	RESERVED	RESERVED
	3	0	RW	N	MR_CPRI_CLK_DIV_SEL_OV	clk divider enable for select, rclk_sel_div_lv
	2	1	RW	N	MR_VCO_TLR_EN	Enable the Cap extension of the VCO for TLR
	1	0	RW	N	RESERVED	RESERVED
	0	0	RW	N	RESERVED	RESERVED

## 9 Application and Implementation

### Note

以下のアプリケーション情報は、TI の製品仕様に含まれるものではなく、TI ではその正確性または完全性を保証いたしません。個々の目的に対する製品の適合性については、お客様の責任で判断していただくこととなります。お客様は自身の設計実装を検証しテストすることで、システムの機能を確認する必要があります。

### 9.1 Application Information

The DS250DF230 is a high-speed retimer which extends the reach of differential channels and cleans jitter and other signal impairments in the process. It can be deployed in a variety of different systems from backplanes to front ports to active cable assemblies. The following sections outline a few typical applications and their associated design considerations.

### 9.2 Typical Applications

The DS250DF230 is typically used in the following application scenarios:

1. [Front-Port Jitter Cleaning Applications](#)
2. [Active Cable Applications](#)
3. [Backplane and Mid-Plane Applications](#)





図 9-1. Typical Uses for the DS250DF230 in a System

### 9.2.1 Front-Port Jitter Cleaning Applications

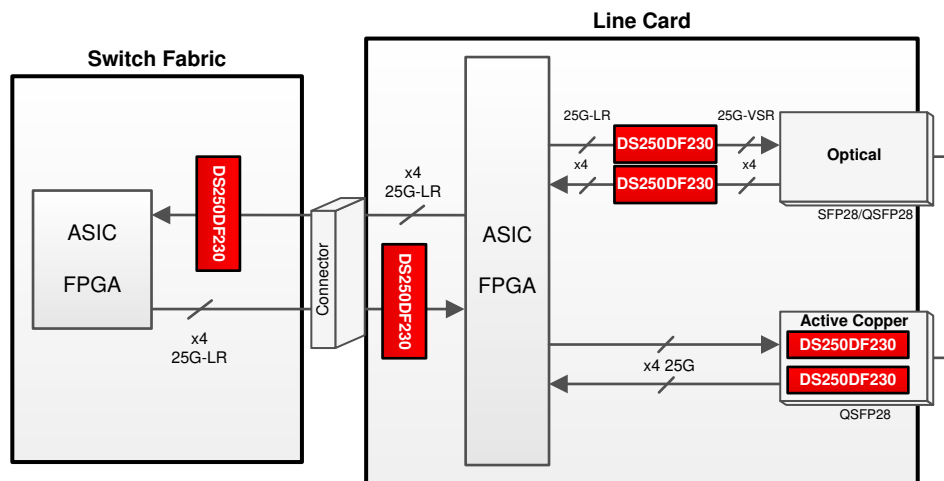

The DS250DF230 has strong equalization capabilities that allow it to equalize insertion loss, reduce jitter, and extend the reach of front-port interfaces. Two pieces DS250DF230 can be used to support all four egress channels for a 100GbE port. Another two pieces DS250DF230 can be used to support all four ingress channels for the same 100GbE ports. Alternatively, a single DS250DF230 can be used to support all egress channels for two 25GbE ports, and another DS250DF230 can be used to support all two ingress channels for the same four 25GbE ports.

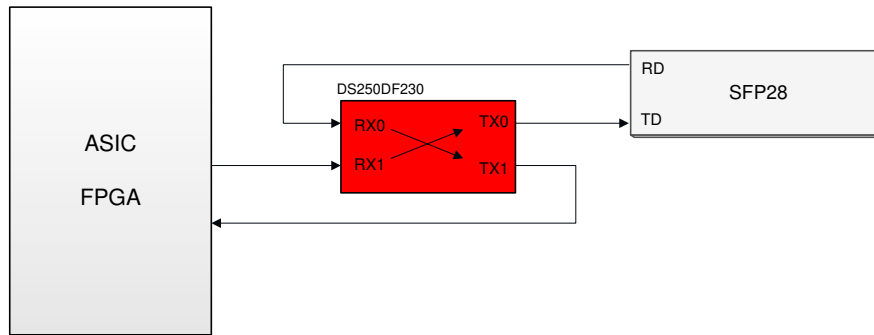
A flow-through pinout for the high-speed signals on DS250DF230 makes placement and routing easy for unidirectional application. By using the 2x2 cross point inside the device, DS250DF230 can also be configured for , where one single device supports both egress and ingress channels.



 **9-2. Bidirectional Application**

For applications which require IEEE802.3 100GBASE-CR4 or 25GBASE-CR auto-negotiation and link training, a linear repeater device such as the [DS280BR820](#) (or similar) is recommended.

 [9-3](#) shows this configuration, and  [9-4](#) shows an example simplified schematic for a typical front-port application.

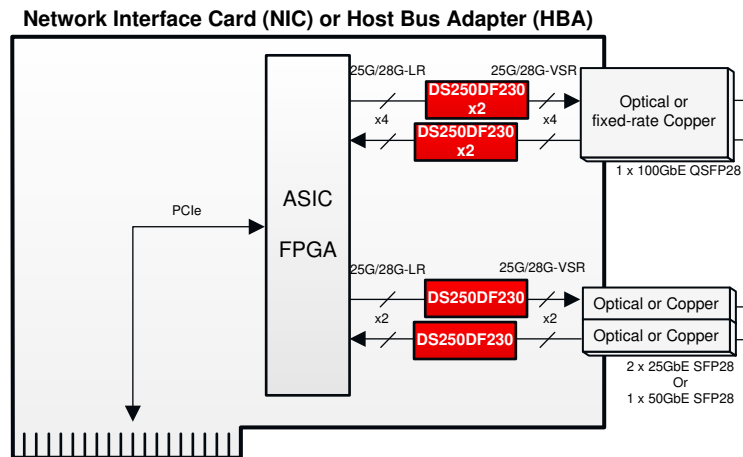

 **9-3. Front-Port Application Block Diagram**

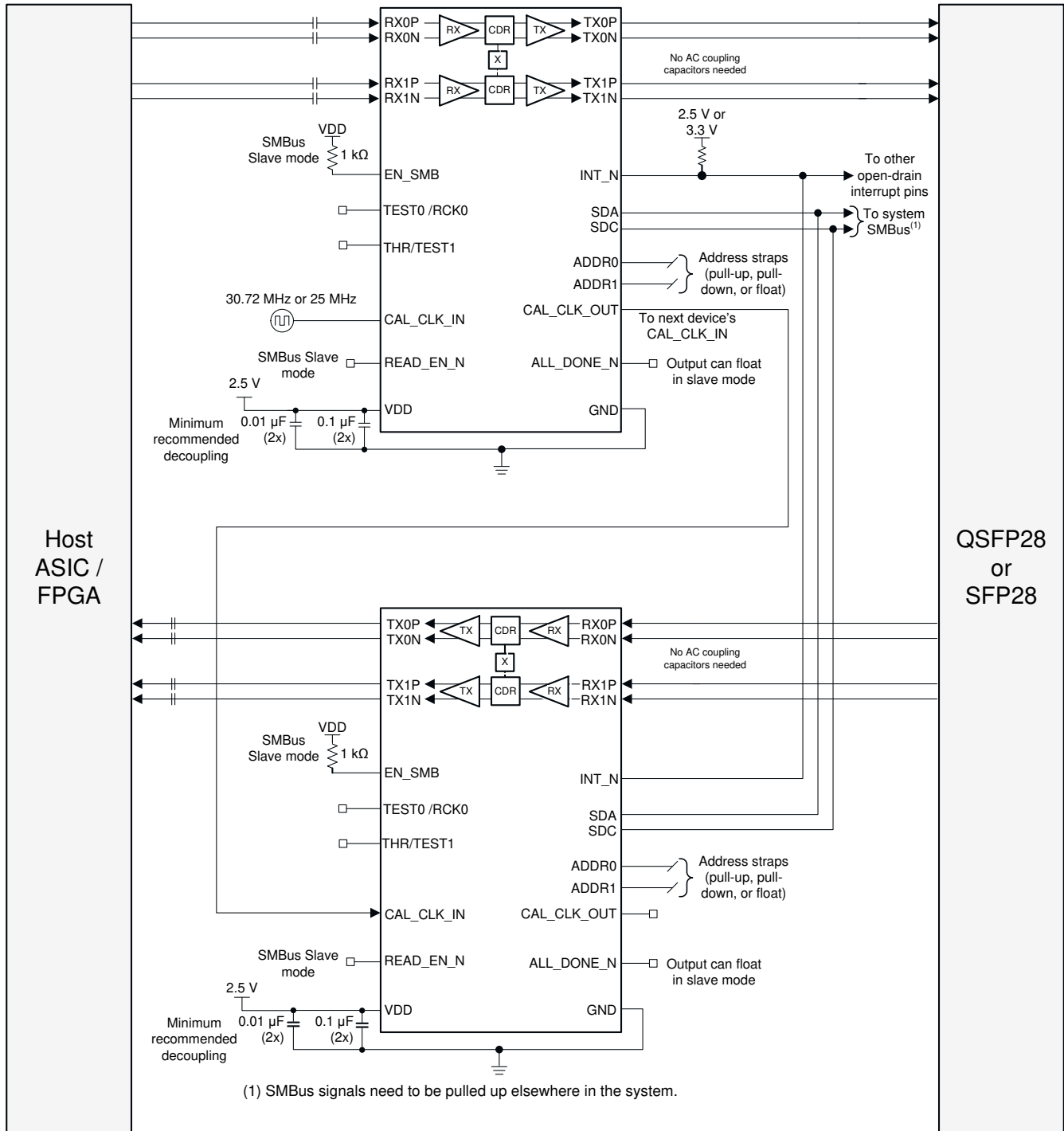

**9-4. Front-Port Application Schematic**

### 9.2.1.1 Design Requirements

For this design example, the following guidelines outlined in 表 9-1 apply.

**表 9-1. Front-Port Application Design Guidelines**

DESIGN PARAMETER	REQUIREMENT
AC-coupling capacitors	<i>Egress (ASIC-to-module) direction:</i> AC-coupling capacitors in the range of 100 to 220 nF are required for the RX inputs and are NOT required for the TX outputs. <i>Ingress (module-to-ASIC) direction:</i> AC-coupling capacitors in the range of 100 to 220 nF are required for the TX outputs and are NOT required for the RX inputs.
Input channel insertion loss	≤ 35 dB at 25.78125-Gbps Nyquist frequency (12.9 GHz)
Output channel insertion loss	<i>Egress (ASIC-to-module) direction:</i> Follow CAUI-4 / CEI-25G-VSR host channel requirements (approximately 7 dB at 12.9 GHz). <i>Ingress (module-to-ASIC) direction:</i> Depends on downstream ASIC / FPGA capabilities. The DS250DF230 has a low-jitter output driver with 3-tap FIR filter for equalizing a portion of the output channel.
Host ASIC TX launch amplitude	800 mVppd to 1200 mVppd.
Host ASIC TX FIR filter	Depends on channel loss. Refer to the <a href="#">Setting the Output V<sub>OD</sub>, Pre-Cursor, and Post-Cursor Equalization</a> section.

### 9.2.1.2 Detailed Design Procedure

The design procedure for front-port applications is as follows:

- Determine the total number of channels on the board which require a DS250DF230 for signal conditioning. This will dictate the total number of DS250DF230 devices required for the board. It is generally recommended that channels connected to the same front-port cage be grouped together in the same DS250DF230 device. This will simplify the device settings, as similar loss channels generally use similar settings.
- Determine the maximum current draw required for all DS250DF230 retimers. This may impact the selection of the regulator for the 2.5-V supply rail. To calculate the maximum current draw, multiply the maximum transient power supply current by the total number of DS250DF230 devices.
- Determine the maximum operational power consumption for the purpose of thermal analysis. There are two ways to approach this calculation:
  - Maximum mission-mode operational power consumption is when all channels are locked and re-transmitting the data which is received. PRBS pattern checkers/generators are not used in this mode because normal traffic cannot be checked with a PRBS checker. For this calculation, multiply the worst-case power consumption in mission mode by the total number of DS250DF230 devices.
  - Maximum debug-mode operational power consumption is when all channels are locked and re-transmitting the data which is received. At the same time, some channels' PRBS checkers or generators may be enabled. For this calculation, multiply the worst-case power consumption in debug mode by the total number of DS250DF230 devices.
- Determine the SMBus address scheme needed to uniquely address each DS250DF230 device on the board, depending on the total number of devices identified in step 2. Each DS250DF230 can be strapped with one of 16 unique SMBus addresses. If there are more DS250DF230 devices on the board than the number of unique SMBus addresses which can be assigned, then use an I2C expander like the **TCA/PCA family of I2C/SMBus switches and multiplexers** to split up the SMBus into multiple busses.
- Determine if the device will be configured from EEPROM (SMBus Master Mode) or from the system I2C bus (SMBus Slave Mode).
  - If SMBus Master Mode will be used, provisions must be made for an EEPROM on the board with 8-bit SMBus address 0xA0. Refer to [SMBus Master Mode](#) for more details on SMBus Master Mode including EEPROM size requirements.
  - If SMBus Slave Mode will be used for all device configurations, an EEPROM is not needed.
- Make provisions in the schematic and layout for standard decoupling capacitors between the device VDD supply and GND. Refer to the pin function description in [Pin Configuration and Functions](#) for more details.

7. Make provisions in the schematic and layout for a 30.72 MHz ( $\pm 100$  ppm) or 25 MHz ( $\pm 100$  ppm) single-ended CMOS clock. Each DS250DF230 retimer buffers the clock on the CAL\_CLK\_IN pin and presents the buffered clock on the CAL\_CLK\_OUT pin. This allows multiple (up to 20) retimers' calibration clocks to be daisy chained to avoid the need for multiple oscillators on the board. If the oscillator used on the board has a 2.5-V CMOS output, then no AC-coupling capacitor or resistor ladder is required at the input to CAL\_CLK\_IN. No AC coupling or resistor ladder is needed between one retimer's CAL\_CLK\_OUT output and the next retimer's CAL\_CLK\_IN input. The final retimer's CAL\_CLK\_OUT output can be left floating.
8. Connect the INT\_N open-drain output to an FPGA or CPU if interrupt monitoring is desired. Note that multiple retimers' INT\_N outputs can be connected together because this is an open-drain output. The common INT\_N net must be pulled high.
9. If the application requires initial CDR lock acquisition at the ambient temperature extremes defined in [Recommended Operating Conditions](#), take care to ensure the operating junction temperature is met as well as the CDR stay-in-lock junction temperature range defined in [Electrical Characteristics](#). For example, if initial CDR lock acquisition occurs at an junction temperature of 110°C, then maintaining CDR lock would require the ambient temperature surrounding the DS250DF230 to be kept above (110°C – TEMP\_LOCK-).

### 9.2.1.3 Application Curves

☒ 9-5 shows a typical output eye diagram for the DS250DF230 operating at 25.78125 Gbps with PRBS9 pattern using FIR main-cursor of +28, pre-cursor of 0 and post-cursor of +3. All other device settings are left at default.

☒ 9-6 shows an example of DS250DF230 FIR transmit equalization while operating at 25.78125 Gbps. In this example, the Tx FIR filter main-cursor is set to +25, post-cursor to –3 and pre-cursor to –3. An 8T pattern is used to evaluate the FIR filter, which consists of 0xFF00. All other device settings are left at default.

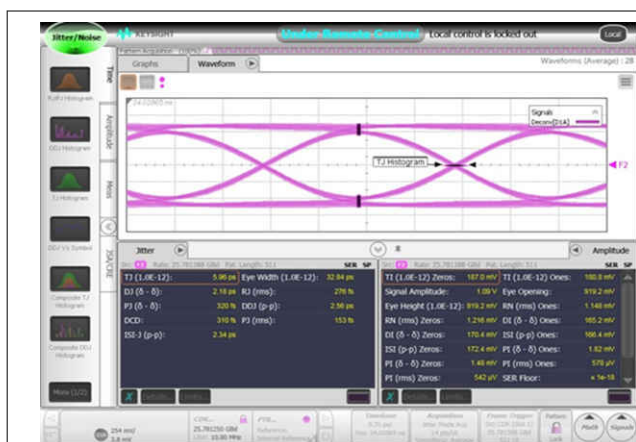



☒ 9-5. DS250DF230 Operating at 25.78125 Gbps



☒ 9-6. DS250DF230 FIR Transmit Equalization While Operating at 25.78125 Gbps

### 9.2.2 Active Cable Applications

The DS250DF230 has strong equalization capabilities that allow it to recover data over long and/or thin-gauge copper cables. Two pcs DS250DF230s can be used on a QSFP28 paddle card to create a half-active cable assembly which is longer and/or thinner than passive cables. Alternatively, four pcs DS250DF230 devices can be used on a QSFP28 paddle card to create a full-active cable assembly and achieve even longer reach and/or thinner cables.

 9-7 shows these configurations,  9-8 shows an example simplified schematic for a half-active cable application, and  9-9 shows an example simplified schematic for a full-active cable application.

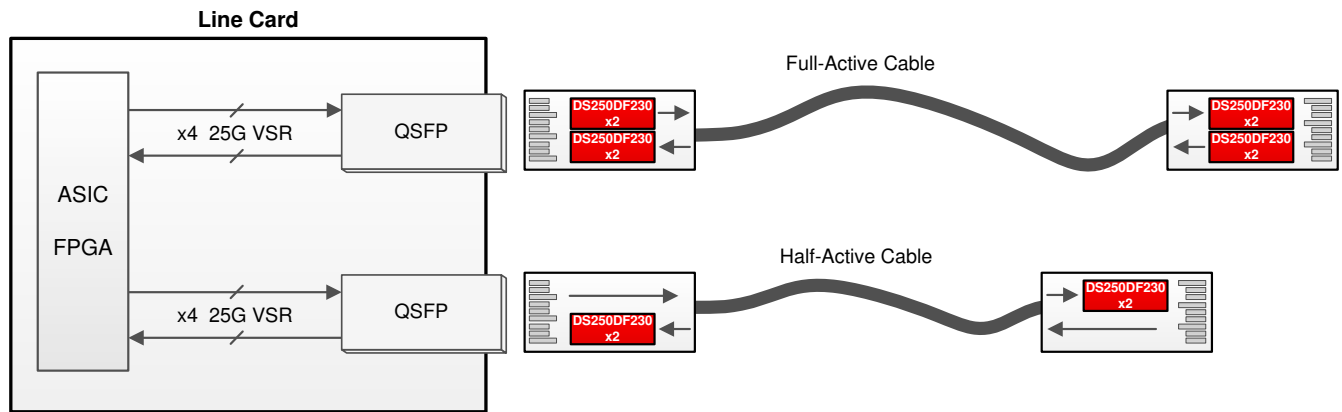

 9-7. Active Cable Application Block Diagram

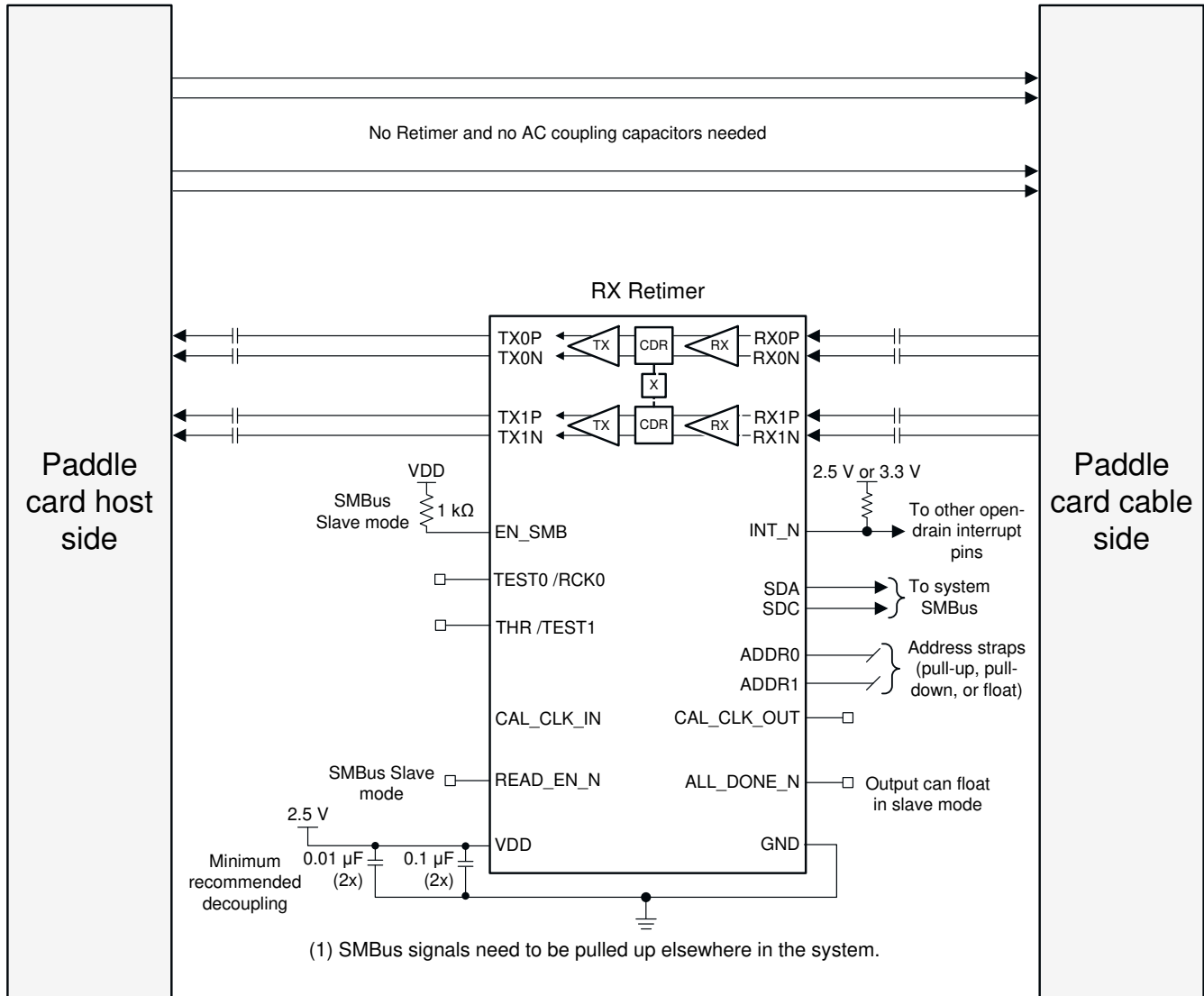

**图 9-8. Half-Active Cable Application Schematic**

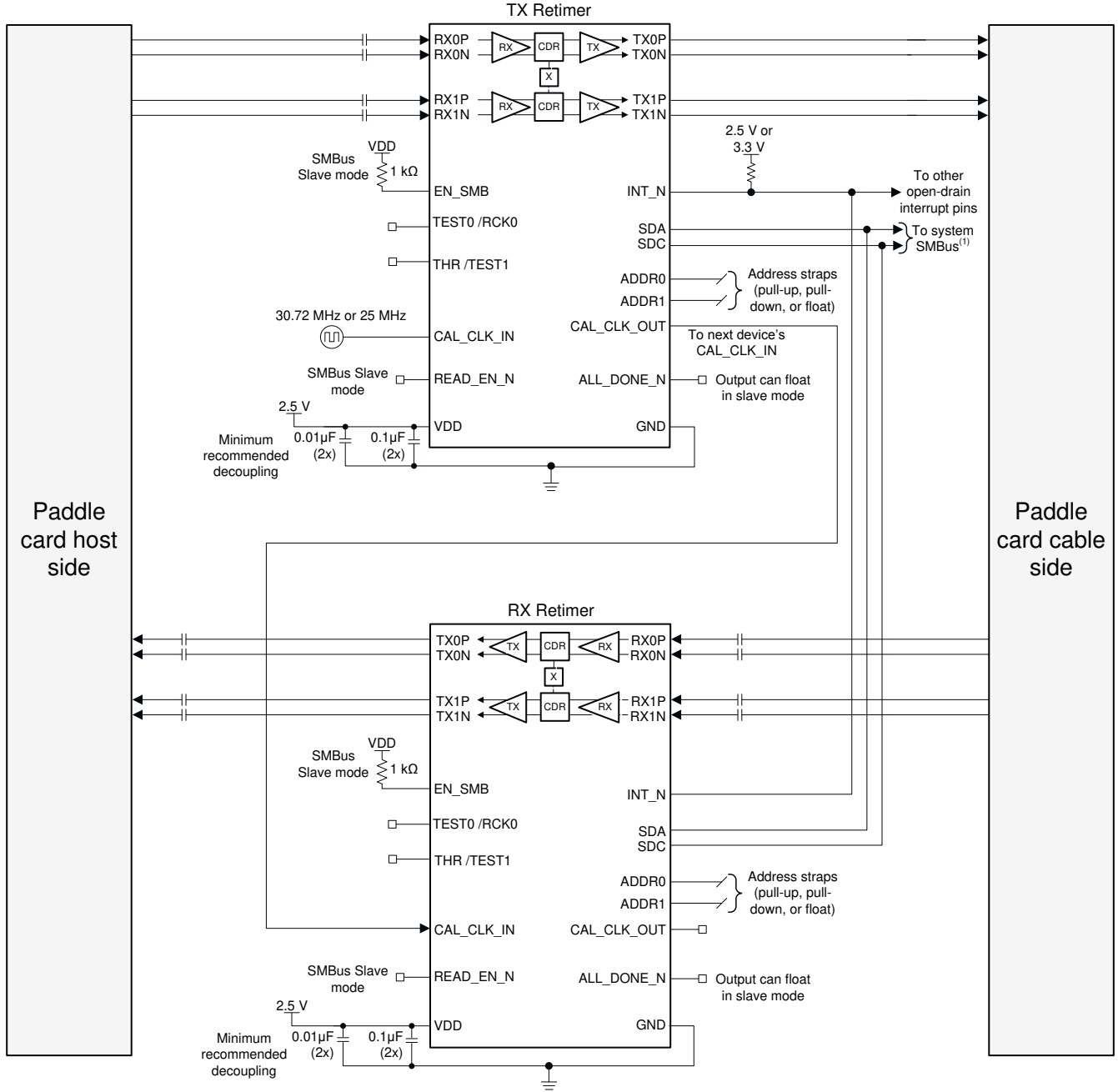

9-9. Full-Active Cable Application Schematic

### 9.2.2.1 Design Requirements

For this design example, the following guidelines outlined in 表 9-2 and 表 9-3 apply.

**表 9-2. Half-Active Cable Application Design Guidelines**

DESIGN PARAMETER	REQUIREMENT
Device placement	Place the DS250DF230s on the receive side of the paddle card such that it is receiving data from the cable, and transmitting towards the host.
AC-coupling capacitors	100-nF, AC-coupling capacitors are required for the RX inputs and the TX outputs.
Cable insertion loss	The raw cable insertion loss including the insertion loss of the paddle card must be $\leq 27$ dB at 25.78125-Gbps Nyquist frequency (12.9 GHz). This is to ensure that the total loss at the input to the DS250DF230 is $\leq 35$ dB at 12.9 GHz. Assuming a worst-case host-side PCB loss of 7 dB, plus a connector loss of 1 dB, the remaining loss allocated for the raw cable and paddle cards is 27 dB.

**表 9-3. Full-Active Cable Application Design Guidelines**

DESIGN PARAMETER	REQUIREMENT
Device placement	A full-active QSFP cable will use 4 pieces of DS250DF230 per paddle card. Typically, two devices will be placed on each side of the paddle card.
AC-coupling capacitors	<i>Transmit-side Retimer:</i> 100-nF, AC coupling capacitors are required for the RX inputs and are not required for the TX outputs. This link segment will be AC coupled on the paddle card at the opposite end of the cable. <i>Receive-side Retimer:</i> 100-nF, AC-coupling capacitors are required for the RX inputs and the TX outputs.
Cable insertion loss	The raw cable insertion loss including the insertion loss of the paddle card must be $\leq 35$ dB at 25.78125-Gbps Nyquist frequency (12.9 GHz).

### 9.2.2.2 Detailed Design Procedure

The design procedure for active cable applications is as follows:

- Determine the maximum current draw required for one or more of the DS250DF230 retimers on the paddle card. This may impact the selection of the regulator for the 2.5-V supply rail. To calculate the maximum current draw, multiply the maximum transient power supply current by the total number of DS250DF230 devices.
- Determine the maximum operational power consumption for the purpose of thermal analysis. There are two ways to approach this calculation:
  - Maximum mission-mode operational power consumption is when all channels are locked and re-transmitting the data which is received. PRBS pattern checkers/generators are not used in this mode because normal traffic cannot be checked with a PRBS checker. For this calculation, multiply the worst-case power consumption in mission mode by the total number of DS250DF230 devices.
  - Maximum debug-mode operational power consumption is when all channels are locked and re-transmitting the data which is received. At the same time, some channels' PRBS checkers or generators may be enabled. For this calculation, multiply the worst-case power consumption in debug mode by the total number of DS250DF230 devices.
- Determine the SMBus address for one or more of the DS250DF230 retimers. The ADDR[1:0] pins can be left floating for an 8-bit SMBus slave address of 0x44. For the second DS250DF230, a single pullup or pulldown resistor can be used on one address pin. For example, with ADDR0 = Float and ADDR1 = 1 k $\Omega$  to GND, the 8-bit SMBus slave address will be 0x34.

4. Determine if the device will be configured from EEPROM (SMBus Master Mode) or from the system I2C bus (SMBus Slave Mode).
  - a. If SMBus Master Mode will be used, provisions must be made for an EEPROM on the board with 8-bit SMBus address 0xA0. Refer to [SMBus Master Mode](#) for more details on SMBus Master Mode including EEPROM size requirements.
  - b. If SMBus Slave Mode will be used for all device configurations, for example when one or more of the retimers is configured with a microcontroller, an EEPROM is not needed.
5. Make provisions in the schematic and layout for standard decoupling capacitors between the device VDD supply and GND. Refer to the pin function description in [Pin Configuration and Functions](#) for more details.
6. Make provisions in the schematic and layout for a 30.72-MHz ( $\pm 100$  ppm) or 25-MHz ( $\pm 100$  ppm) single-ended CMOS clock. The DS250DF230 retimer buffers the clock on the CAL\_CLK\_IN pin and presents the buffered clock on the CAL\_CLK\_OUT pin. When using two Retimers on a paddle card, only one 30.72-MHz or 25-MHz clock is required. The CAL\_CLK\_OUT pin of one retimer can be connected to the CAL\_CLK\_IN pin of the other retimer.
7. Connect the INT\_N open-drain output to the paddle card MCU if interrupt monitoring is desired, otherwise leave it floating. Note that multiple retimers' INT\_N outputs can be connected together because this is an open-drain output. The common INT\_N net should be pulled high.
8. If the application requires initial CDR lock acquisition at the ambient temperature extremes defined in [Recommended Operating Conditions](#), take care to ensure the operating junction temperature is met as well as the CDR stay-in-lock junction temperature range defined in [Electrical Characteristics](#). For example, if initial CDR lock acquisition occurs at an junction temperature of 110°C, then maintaining CDR lock would require the junction temperature on DS250DF230 to be kept above (110°C – TEMP<sub>LOCK-</sub>).

### 9.2.2.3 Application Curves

See [Application Curves](#) in section [Front-Port Jitter Cleaning Applications](#).

### 9.2.3 Backplane and Mid-Plane Applications

The DS250DF230 has strong equalization capabilities that allow it to recover data over channels up to 35-dB insertion loss. As a result, the optimum placement for the DS250DF230 in a backplane/mid-plane application is with the higher-loss channel segment at the input and the lower-loss channel segment at the output. This reduces the equalization burden on the downstream ASIC/FPGA, as the DS250DF230 is equalizing a majority of the overall channel. This type of asymmetric placement is not a requirement, but when an asymmetric placement is required due to the presence of a passive backplane or mid-plane, then this becomes the recommended placement.

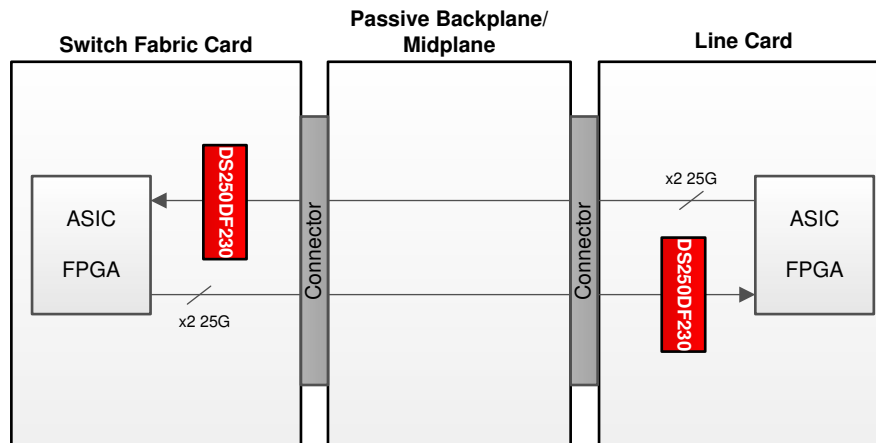

9-10. Backplane/Mid-Plane Application Block Diagram

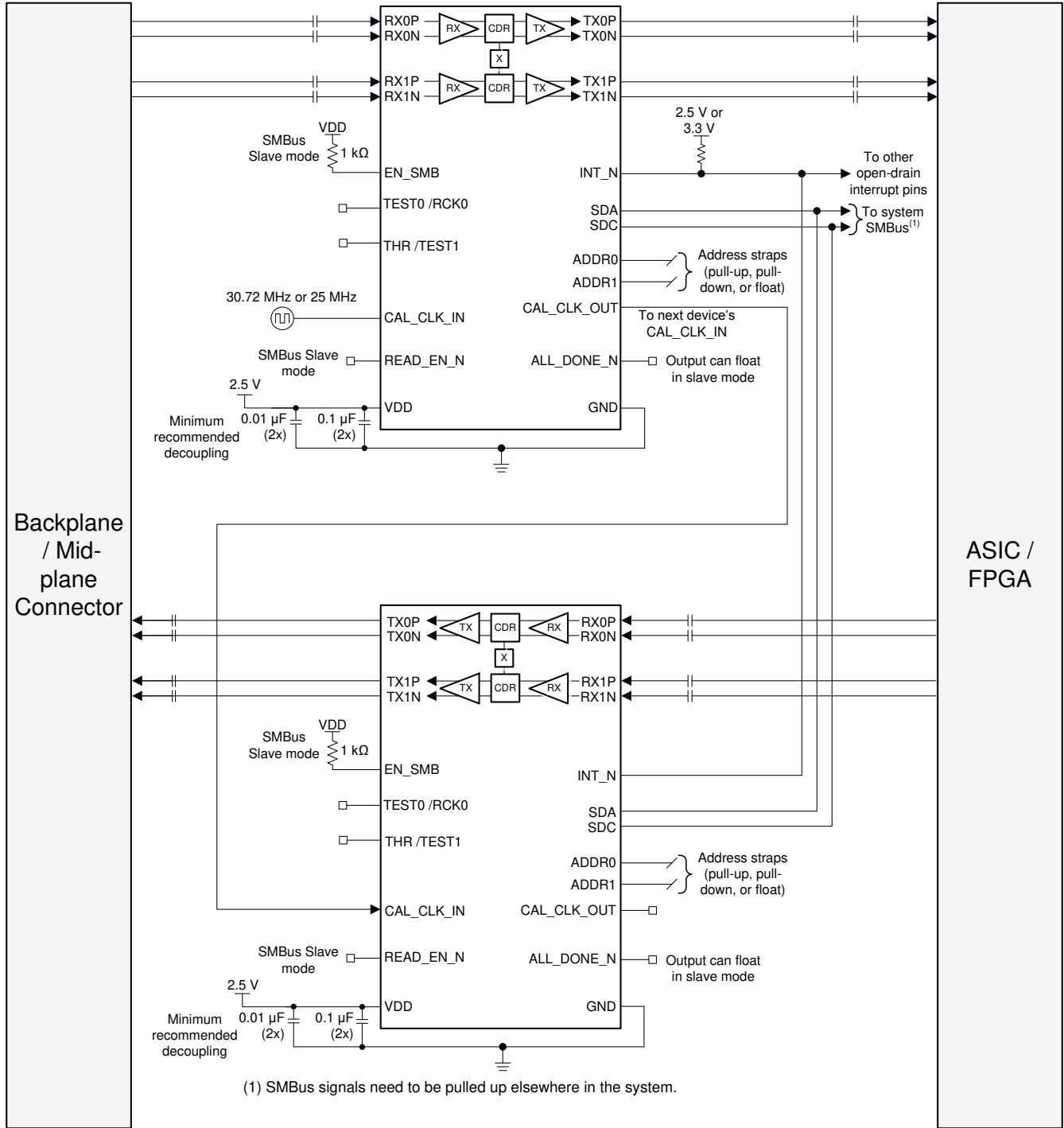

9-11. Backplane/Mid-Plane Application Schematic

### 9.2.3.1 Design Requirements

For this design example, the following guidelines outlined in 表 9-4 apply.

**表 9-4. Backplane/Mid-Plane Application Design Guidelines**

DESIGN PARAMETER	REQUIREMENT
AC coupling capacitors	AC-coupling capacitors in the range of 100 to 220 nF are required for the RX inputs and TX outputs.
Input channel insertion loss	≤ 35 dB at 25.78125-Gbps Nyquist frequency (12.9 GHz)
Output channel insertion loss	Depends on downstream ASIC / FPGA capabilities. The DS250DF230 has a low-jitter output driver with 3-tap FIR filter for equalizing a portion of the output channel.
Link partner TX launch amplitude	800 mVppd to 1200 mVppd
Link partner TX FIR filter	Depends on channel loss. Refer to the <a href="#">Setting the Output <math>V_{OD}</math>, Pre-Cursor, and Post-Cursor Equalization</a> section.

### 9.2.3.2 Detailed Design Procedure

The design procedure for backplane/mid-plane applications is as follows:

- Determine the total number of channels on the board which require a DS250DF230 for signal conditioning. This will dictate the total number of DS250DF230 devices required for the board. It is generally recommended that channels with similar total insertion loss on the board be grouped together in the same DS250DF230 device. This will simplify the device settings, as similar loss channels generally use similar settings.
- Determine the maximum current draw required for all DS250DF230 retimers. This may impact the selection of the regulator for the 2.5-V supply rail. To calculate the maximum current draw, multiply the maximum transient power supply current by the total number of DS250DF230 devices.
- Determine the maximum operational power consumption for the purpose of thermal analysis. There are two ways to approach this calculation:
  - Maximum mission-mode operational power consumption is when all channels are locked and re-transmitting the data which is received. PRBS pattern checkers/generators are not used in this mode because normal traffic cannot be checked with a PRBS checker. For this calculation, multiply the worst-case power consumption in mission mode by the total number of DS250DF230 devices.
  - Maximum debug-mode operational power consumption is when all channels are locked and re-transmitting the data which is received. At the same time, some channels' PRBS checkers or generators may be enabled. For this calculation, multiply the worst-case power consumption in debug mode by the total number of DS250DF230 devices.
- Determine the SMBus address scheme needed to uniquely address each DS250DF230 device on the board, depending on the total number of devices identified in step 2. Each DS250DF230 can be strapped with one of 16 unique SMBus addresses. If there are more DS250DF230 devices on the board than the number of unique SMBus addresses which can be assigned, then use an I2C expander like the **TCA/PCA family of I2C/SMBus switches and multiplexers** to split up the SMBus into multiple busses.
- Determine if the device will be configured from EEPROM (SMBus Master Mode) or from the system I2C bus (SMBus Slave Mode).
  - If SMBus Master Mode will be used, provisions must be made for an EEPROM on the board with 8-bit SMBus address 0xA0. Refer to [SMBus Master Mode](#) for more details on SMBus Master Mode including EEPROM size requirements.
  - If SMBus Slave Mode will be used for all device configurations, an EEPROM is not needed.
- Make provisions in the schematic and layout for standard decoupling capacitors between the device VDD supply and GND. Refer to the pin function description in [Pin Configuration and Functions](#) for more details.

7. Make provisions in the schematic and layout for a 30.72-MHz ( $\pm 100$  ppm) or 25-MHz ( $\pm 100$  ppm) single-ended CMOS clock. Each DS250DF230 retimer buffers the clock on the CAL\_CLK\_IN pin and presents the buffered clock on the CAL\_CLK\_OUT pin. This allows multiple (up to 20) retimers' calibration clocks to be daisy chained to avoid the need for multiple oscillators on the board. If the oscillator used on the board has a 2.5-V CMOS output, then no AC-coupling capacitor or resistor ladder is required at the input to CAL\_CLK\_IN. No AC coupling or resistor ladder is needed between one retimer's CAL\_CLK\_OUT output and the next retimer's CAL\_CLK\_IN input. The final retimer's CAL\_CLK\_OUT output can be left floating.
8. Connect the INT\_N open-drain output to an FPGA or CPU if interrupt monitoring is desired. Note that multiple retimers' INT\_N outputs can be connected together because this is an open-drain output. The common INT\_N net must be pulled high.
9. If the application requires initial CDR lock acquisition at the ambient temperature extremes defined in [Recommended Operating Conditions](#), take care to ensure the operating junction temperature is met as well as the CDR stay-in-lock junction temperature range defined in [Electrical Characteristics](#). For example, if initial CDR lock acquisition occurs at an junction temperature of 110 °C, then maintaining CDR lock would require the junction temperature on DS250DF230 to be kept above (110°C - TEMP<sub>LOCK</sub>).

### 9.2.3.3 Application Curves

See [Application Curves](#) in section [Front-Port Jitter Cleaning Applications](#).

## 10 Power Supply Recommendations

Follow these general guidelines when designing the power supply:

1. The power supply must be designed to provide the recommended operating conditions outlined in [Specifications](#) in terms of DC voltage, AC noise, and start-up ramp time.
2. The maximum current draw for the DS250DF230 is provided in [Specifications](#). This figure can be used to calculate the maximum current the power supply must provide. Typical mission-mode current draw can be inferred from the typical power consumption in [Specifications](#).
3. The DS250DF230 does not require any special power supply filtering (that is, ferrite bead), provided the recommended operating conditions are met. Only standard supply decoupling is required. Refer to the [Pin Configuration and Functions](#) section for details concerning the recommended supply decoupling.

## 11 Layout

### 11.1 Layout Guidelines

Follow these guidelines when designing the layout:

1. Decoupling capacitors must be placed as close to the VDD pins as possible. Placing them directly underneath the device is one option if the board design permits.
2. High-speed differential signals TXnP/TXnN and RXnP/RXnN must be tightly coupled, skew matched, and impedance controlled.
3. Vias must be avoided when possible on the high-speed differential signals. When vias must be used, take care to minimize the via stub, either by transitioning through most or all layers, or by back drilling.
4. GND relief can be used beneath the high-speed differential signal pads to improve signal integrity by counteracting the pad capacitance.
5. GND relief can be used beneath the AC-coupling capacitor pads to improve signal integrity by counteracting the pad capacitance.
6. GND vias must be placed directly beneath the device connecting the GND plane attached to the device to the GND planes on other layers. This has the added benefit of improving thermal conductivity from the device to the board.
7. If vias are used for the high-speed signals, the ground via must be implemented adjacent to the signal via to provide return path and isolation. For differential pair, the typical via configuration is *ground-signal-signal-ground*.

### 11.2 Layout Examples

The example layouts in [Figure 11-1](#) through [Figure 11-5](#) demonstrate how all signals can be escaped from the BGA array using microstrip routing on a generic multi-layer stackup.

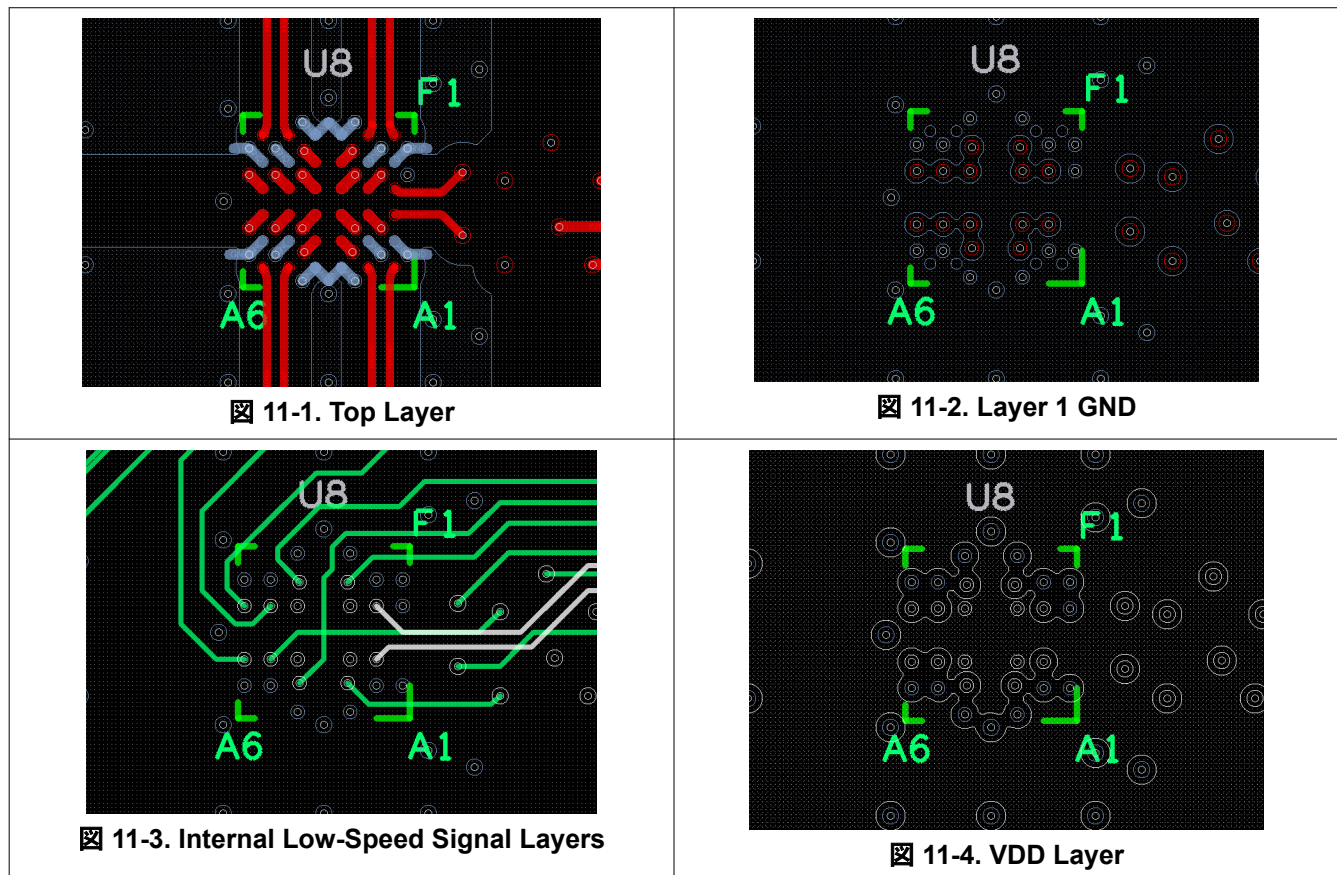

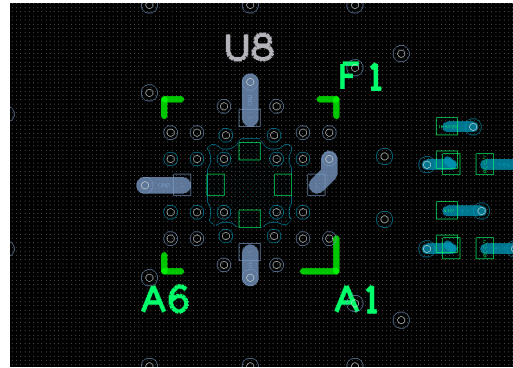

 11-5. Bottom Layer

## 12 Device and Documentation Support

### 12.1 Device Support

#### 12.1.1 Development Support

For additional information, see TI's Surface Mount Technology (SMT) References at:

<http://focus.ti.com/quality/docs> under the *Quality & Lead (Pb)-Free Data* menu.

For device and channel model simulation, refer to the DS250DF230 IBIS-AMI Model:

- Texas Instruments, [DS250DF230 IBIS-AMI Model IBIS Model](#)

Click [here](#) to request access to the DS250DF230 IBIS-AMI Model (SNLM215) in the DS250DF230 MySecure folder.

### 12.2 Documentation Support

#### 12.2.1 Related Documentation

For related documentation, see the following:

- Texas Instruments [DS2x0DF810](#), [DS250DFx10](#), [DS250DF230 Programmer's Guide](#)

Click [here](#) to request access to the DS250DF230 Programming Guide in the DS250DF230 MySecure folder.

### 12.3 Receiving Notification of Documentation Updates

To receive notification of documentation updates, navigate to the device product folder on [ti.com](#). Click on *Subscribe to updates* to register and receive a weekly digest of any product information that has changed. For change details, review the revision history included in any revised document.

### 12.4 サポート・リソース

TI E2E™ サポート・フォーラムは、エンジニアが検証済みの回答と設計に関するヒントをエキスパートから迅速かつ直接得ることができる場所です。既存の回答を検索したり、独自の質問をしたりすることで、設計に必要な支援を迅速に得ることができます。

リンクされているコンテンツは、該当する貢献者により、現状のまま提供されるものです。これらは TI の仕様を構成するものではなく、必ずしも TI の見解を反映したものではありません。TI の[使用条件](#)を参照してください。

### 12.5 Trademarks

TI E2E™ is a trademark of Texas Instruments.

すべての商標は、それぞれの所有者に帰属します。

## 13 Electrostatic Discharge Caution



This integrated circuit can be damaged by ESD. Texas Instruments recommends that all integrated circuits be handled with appropriate precautions. Failure to observe proper handling and installation procedures can cause damage.

ESD damage can range from subtle performance degradation to complete device failure. Precision integrated circuits may be more susceptible to damage because very small parametric changes could cause the device not to meet its published specifications.

## 14 Glossary

[TI Glossary](#) This glossary lists and explains terms, acronyms, and definitions.

## 15 Mechanical, Packaging, and Orderable Information

The following pages include mechanical, packaging, and orderable information. This information is the most current data available for the designated devices. This data is subject to change without notice and revision of this document. For browser-based versions of this data sheet, refer to the left-hand navigation.

**PACKAGING INFORMATION**

Orderable part number	Status (1)	Material type (2)	Package   Pins	Package qty   Carrier	RoHS (3)	Lead finish/ Ball material (4)	MSL rating/ Peak reflow (5)	Op temp (°C)	Part marking (6)
<a href="#">DS250DF230RTVR</a>	Active	Production	WQFN (RTV)   32	3000   LARGE T&R	Yes	SN	Level-1-260C-UNLIM	-40 to 85	DS250 DF2
DS250DF230RTVR.A	Active	Production	WQFN (RTV)   32	3000   LARGE T&R	Yes	SN	Level-1-260C-UNLIM	-40 to 85	DS250 DF2
DS250DF230RTVR.B	Active	Production	WQFN (RTV)   32	3000   LARGE T&R	Yes	SN	Level-1-260C-UNLIM	-40 to 85	DS250 DF2
<a href="#">DS250DF230RTVT</a>	Active	Production	WQFN (RTV)   32	250   SMALL T&R	Yes	SN	Level-1-260C-UNLIM	-40 to 85	DS250 DF2
DS250DF230RTVT.A	Active	Production	WQFN (RTV)   32	250   SMALL T&R	Yes	SN	Level-1-260C-UNLIM	-40 to 85	DS250 DF2
DS250DF230RTVT.B	Active	Production	WQFN (RTV)   32	250   SMALL T&R	Yes	SN	Level-1-260C-UNLIM	-40 to 85	DS250 DF2
DS250DF230RTVTG4	Active	Production	WQFN (RTV)   32	250   SMALL T&R	Yes	NIPDAU	Level-1-260C-UNLIM	-40 to 85	DS250 DF2
DS250DF230RTVTG4.A	Active	Production	WQFN (RTV)   32	250   SMALL T&R	Yes	NIPDAU	Level-1-260C-UNLIM	-40 to 85	DS250 DF2
DS250DF230RTVTG4.B	Active	Production	WQFN (RTV)   32	250   SMALL T&R	Yes	NIPDAU	Level-1-260C-UNLIM	-40 to 85	DS250 DF2
<a href="#">DS250DF230ZLSR</a>	Active	Production	NFBGA (ZLS)   36	3000   LARGE T&R	Yes	SNAGCU	Level-3-260C-168 HR	-40 to 85	D250DF230
DS250DF230ZLSR.A	Active	Production	NFBGA (ZLS)   36	3000   LARGE T&R	Yes	SNAGCU	Level-3-260C-168 HR	-40 to 85	D250DF230
DS250DF230ZLSR.B	Active	Production	NFBGA (ZLS)   36	3000   LARGE T&R	Yes	SNAGCU	Level-3-260C-168 HR	-40 to 85	D250DF230
<a href="#">DS250DF230ZLST</a>	Active	Production	NFBGA (ZLS)   36	250   SMALL T&R	Yes	SNAGCU	Level-3-260C-168 HR	-40 to 85	D250DF230
DS250DF230ZLST.A	Active	Production	NFBGA (ZLS)   36	250   SMALL T&R	Yes	SNAGCU	Level-3-260C-168 HR	-40 to 85	D250DF230
DS250DF230ZLST.B	Active	Production	NFBGA (ZLS)   36	250   SMALL T&R	Yes	SNAGCU	Level-3-260C-168 HR	-40 to 85	D250DF230

(1) **Status:** For more details on status, see our [product life cycle](#).

(2) **Material type:** When designated, preproduction parts are prototypes/experimental devices, and are not yet approved or released for full production. Testing and final process, including without limitation quality assurance, reliability performance testing, and/or process qualification, may not yet be complete, and this item is subject to further changes or possible discontinuation. If available for ordering, purchases will be subject to an additional waiver at checkout, and are intended for early internal evaluation purposes only. These items are sold without warranties of any kind.

(3) **RoHS values:** Yes, No, RoHS Exempt. See the [TI RoHS Statement](#) for additional information and value definition.

(4) **Lead finish/Ball material:** Parts may have multiple material finish options. Finish options are separated by a vertical ruled line. Lead finish/Ball material values may wrap to two lines if the finish value exceeds the maximum column width.

(5) **MSL rating/Peak reflow:** The moisture sensitivity level ratings and peak solder (reflow) temperatures. In the event that a part has multiple moisture sensitivity ratings, only the lowest level per JEDEC standards is shown. Refer to the shipping label for the actual reflow temperature that will be used to mount the part to the printed circuit board.

(6) **Part marking:** There may be an additional marking, which relates to the logo, the lot trace code information, or the environmental category of the part.

Multiple part markings will be inside parentheses. Only one part marking contained in parentheses and separated by a "~" will appear on a part. If a line is indented then it is a continuation of the previous line and the two combined represent the entire part marking for that device.

**Important Information and Disclaimer:** The information provided on this page represents TI's knowledge and belief as of the date that it is provided. TI bases its knowledge and belief on information provided by third parties, and makes no representation or warranty as to the accuracy of such information. Efforts are underway to better integrate information from third parties. TI has taken and continues to take reasonable steps to provide representative and accurate information but may not have conducted destructive testing or chemical analysis on incoming materials and chemicals. TI and TI suppliers consider certain information to be proprietary, and thus CAS numbers and other limited information may not be available for release.

In no event shall TI's liability arising out of such information exceed the total purchase price of the TI part(s) at issue in this document sold by TI to Customer on an annual basis.

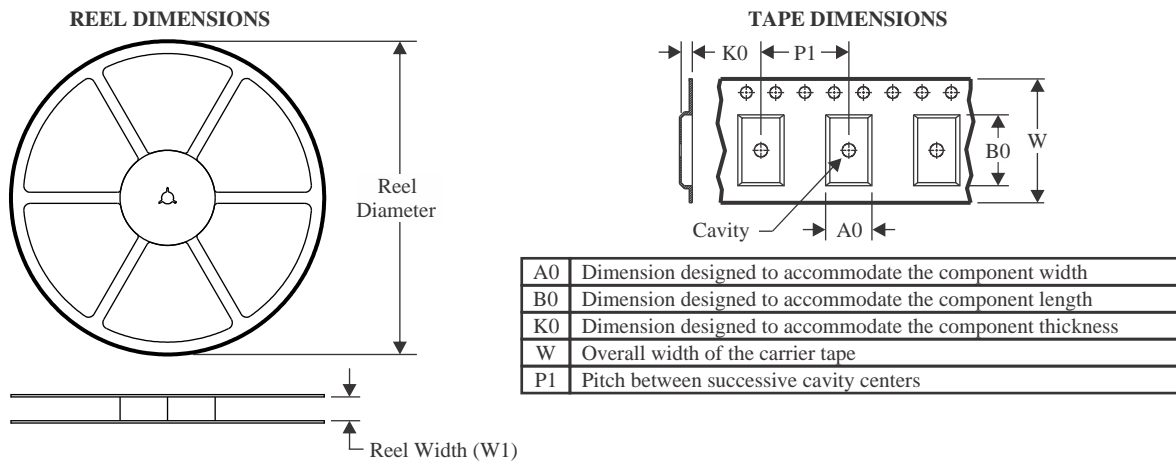
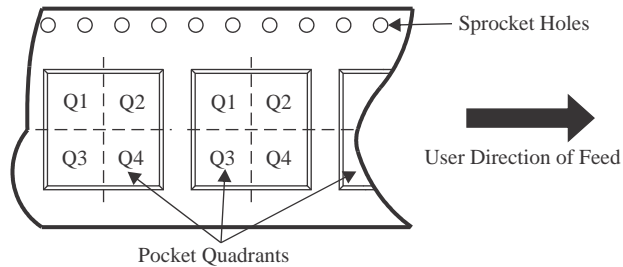
**TAPE AND REEL INFORMATION**

**QUADRANT ASSIGNMENTS FOR PIN 1 ORIENTATION IN TAPE**

\*All dimensions are nominal

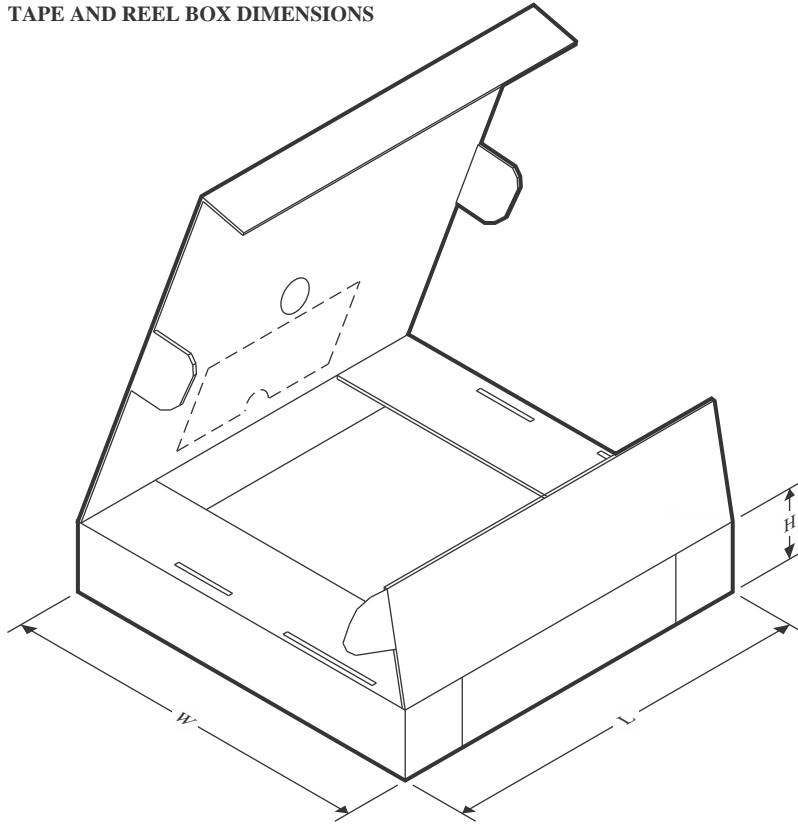
Device	Package Type	Package Drawing	Pins	SPQ	Reel Diameter (mm)	Reel Width W1 (mm)	A0 (mm)	B0 (mm)	K0 (mm)	P1 (mm)	W (mm)	Pin1 Quadrant
DS250DF230RTVR	WQFN	RTV	32	3000	330.0	12.4	5.3	5.3	1.1	8.0	12.0	Q2
DS250DF230RTVT	WQFN	RTV	32	250	180.0	12.4	5.3	5.3	1.1	8.0	12.0	Q2
DS250DF230RTVTG4	WQFN	RTV	32	250	180.0	12.4	5.3	5.3	1.1	8.0	12.0	Q2
DS250DF230ZLSR	NFBGA	ZLS	36	3000	330.0	12.4	5.3	5.3	1.65	8.0	12.0	Q1
DS250DF230ZLST	NFBGA	ZLS	36	250	330.0	12.4	5.3	5.3	1.65	8.0	12.0	Q1

**TAPE AND REEL BOX DIMENSIONS**

\*All dimensions are nominal

Device	Package Type	Package Drawing	Pins	SPQ	Length (mm)	Width (mm)	Height (mm)
DS250DF230RTVR	WQFN	RTV	32	3000	367.0	367.0	35.0
DS250DF230RTVT	WQFN	RTV	32	250	210.0	185.0	35.0
DS250DF230RTVTG4	WQFN	RTV	32	250	210.0	185.0	35.0
DS250DF230ZLSR	NFBGA	ZLS	36	3000	336.6	336.6	31.8
DS250DF230ZLST	NFBGA	ZLS	36	250	336.6	336.6	31.8

# RTV0032E

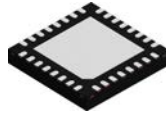

## PACKAGE OUTLINE

WQFN - 0.8 mm max height

PLASTIC QUAD FLATPACK - NO LEAD

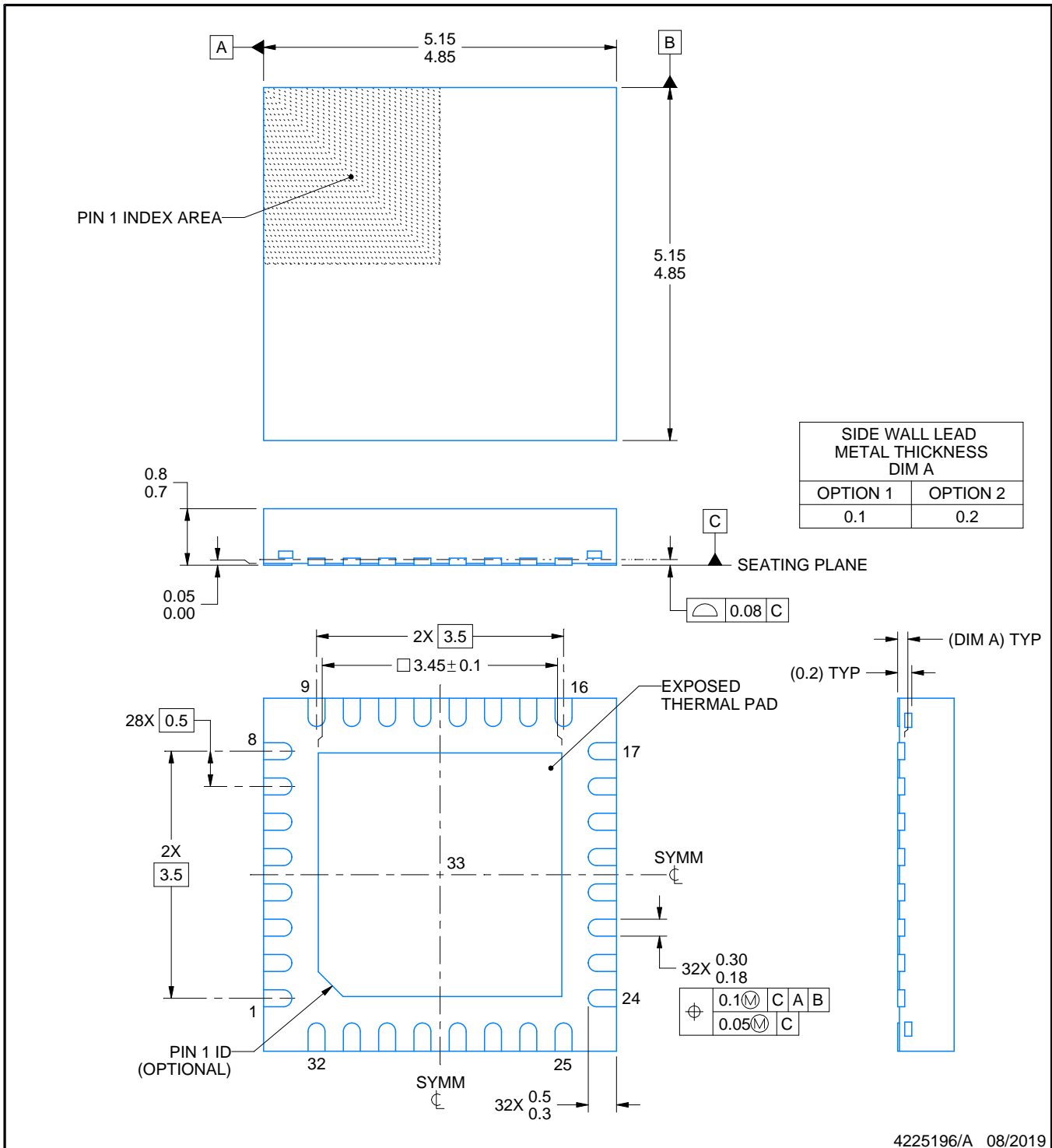

4225196/A 08/2019

**NOTES:**

1. All linear dimensions are in millimeters. Any dimensions in parenthesis are for reference only. Dimensioning and tolerancing per ASME Y14.5M.
2. This drawing is subject to change without notice.
3. The package thermal pad must be soldered to the printed circuit board for thermal and mechanical performance.

# EXAMPLE BOARD LAYOUT

RTV0032E

WQFN - 0.8 mm max height

PLASTIC QUAD FLATPACK - NO LEAD

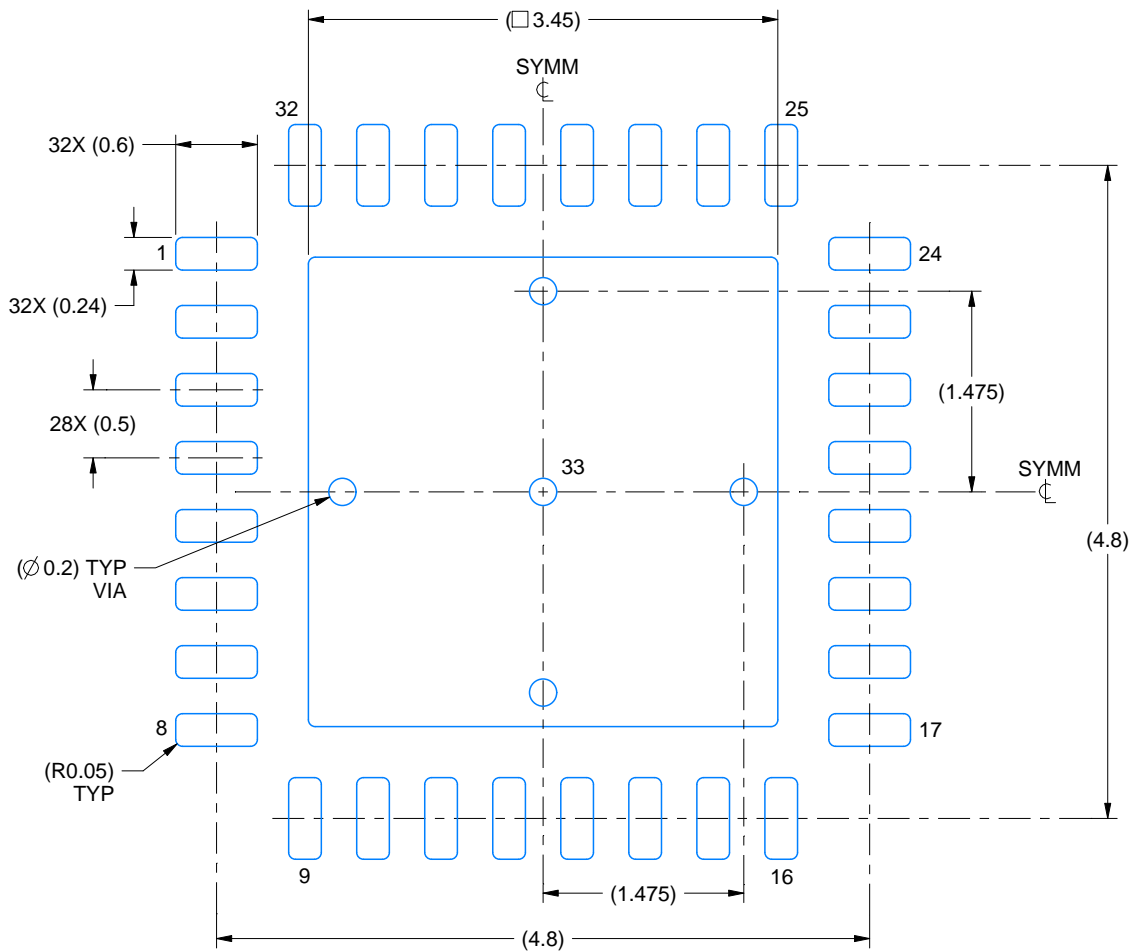

LAND PATTERN EXAMPLE  
SCALE:18X

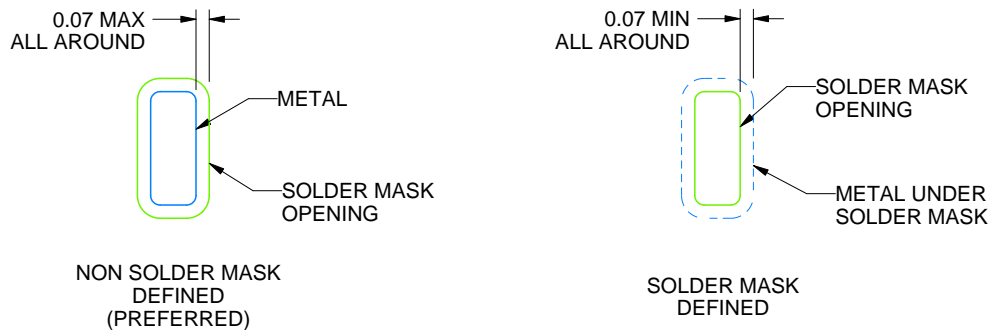

SOLDER MASK DETAILS

4225196/A 08/2019

NOTES: (continued)

4. This package is designed to be soldered to a thermal pad on the board. For more information, see Texas Instruments literature number SLUA271 ([www.ti.com/lit/sluea271](http://www.ti.com/lit/sluea271)).
5. Vias are optional depending on application, refer to device data sheet. If any vias are implemented, refer to their locations shown on this view. It is recommended that vias under paste be filled, plugged or tented.

# EXAMPLE STENCIL DESIGN

RTV0032E

WQFN - 0.8 mm max height

PLASTIC QUAD FLATPACK - NO LEAD

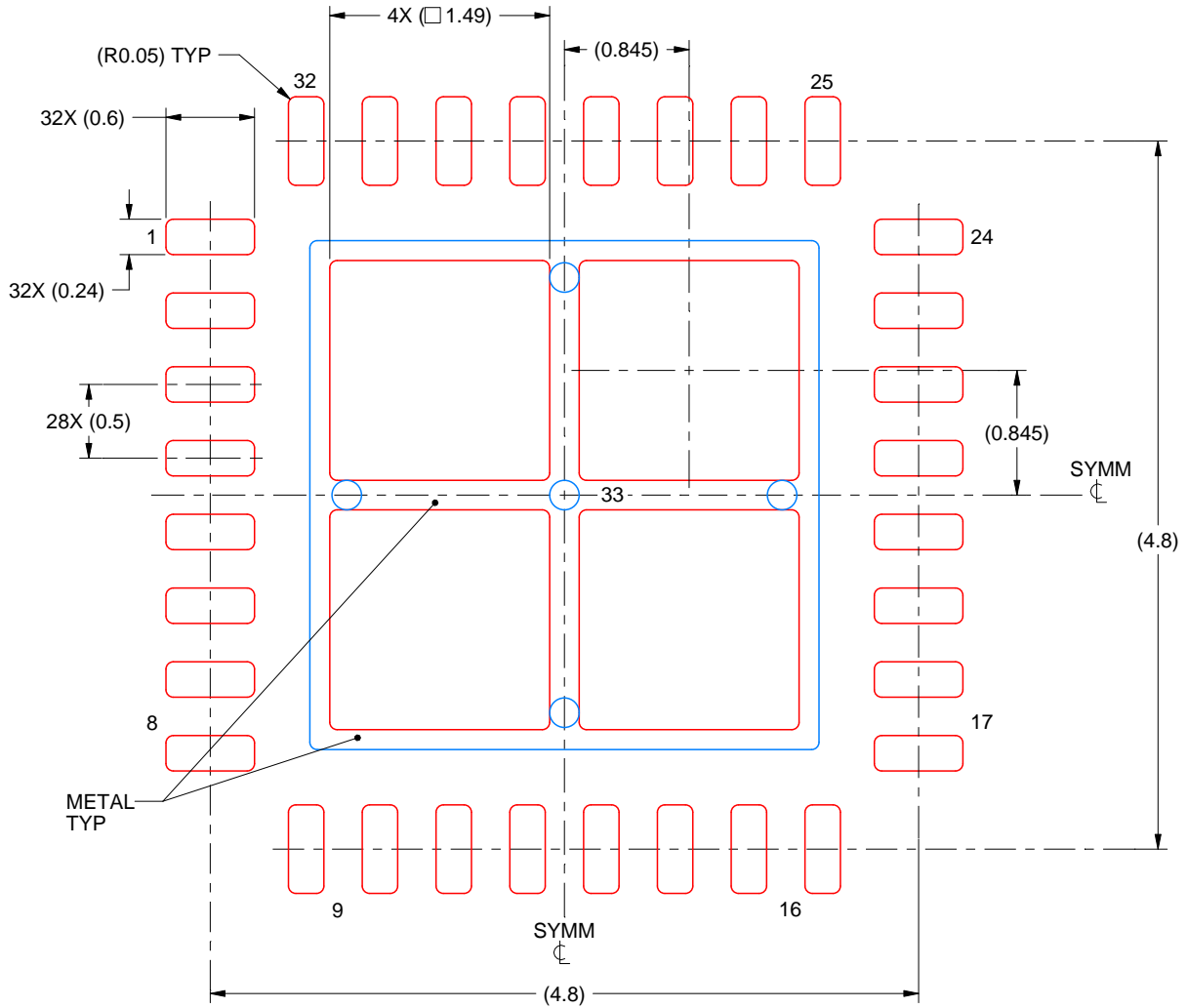

**SOLDER PASTE EXAMPLE**  
 BASED ON 0.125 mm THICK STENCIL

EXPOSED PAD 33:  
 75% PRINTED SOLDER COVERAGE BY AREA UNDER PACKAGE  
 SCALE:20X

4225196/A 08/2019

NOTES: (continued)

6. Laser cutting apertures with trapezoidal walls and rounded corners may offer better paste release. IPC-7525 may have alternate design recommendations.

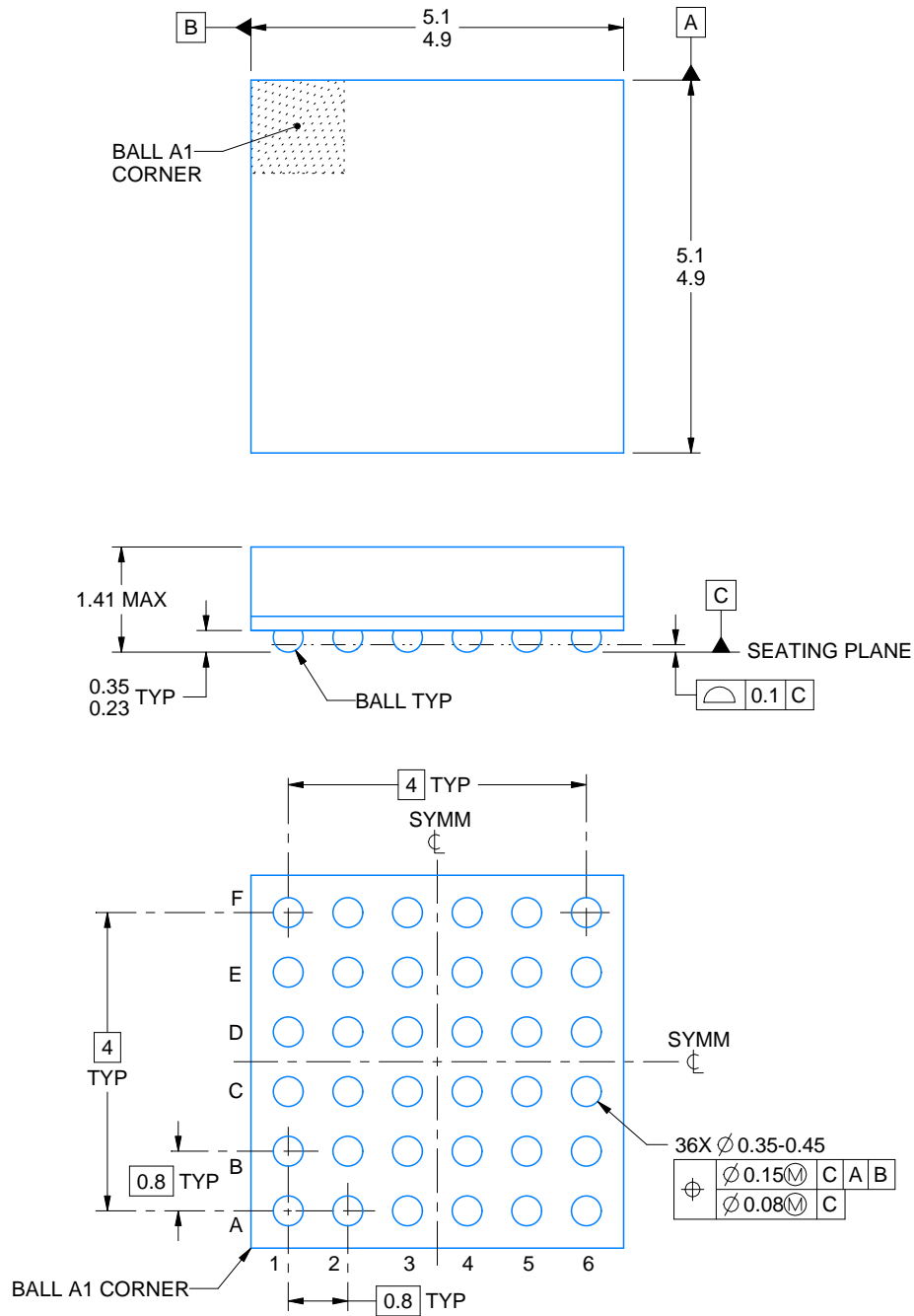
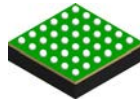

4220412/A 04/2017

NOTES:

1. All linear dimensions are in millimeters. Any dimensions in parenthesis are for reference only. Dimensioning and tolerancing per ASME Y14.5M.
2. This drawing is subject to change without notice.

# EXAMPLE BOARD LAYOUT

ZLS0036A

NFBGA - 1.41 mm max height

BALL GRID ARRAY

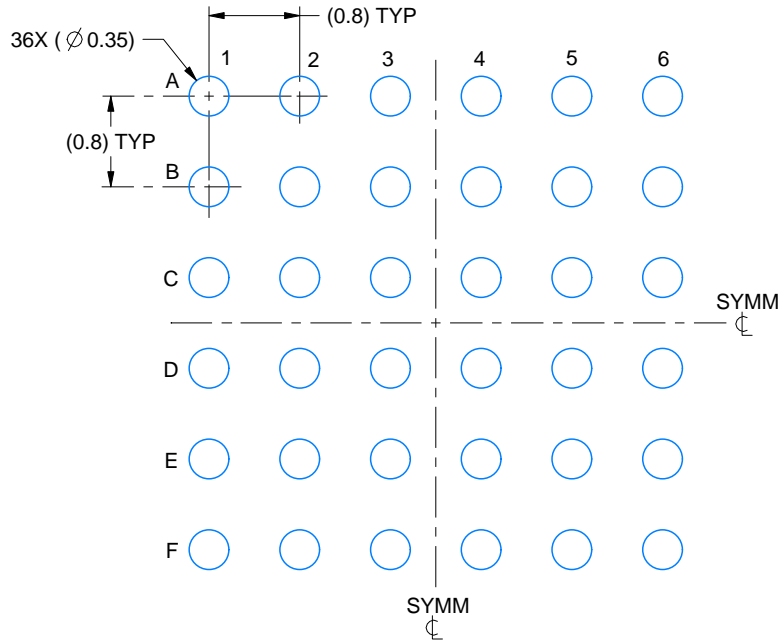

LAND PATTERN EXAMPLE  
EXPOSED METAL SHOWN  
SCALE:15X



SOLDER MASK DETAILS  
NOT TO SCALE

4220412/A 04/2017

NOTES: (continued)

- Final dimensions may vary due to manufacturing tolerance considerations and also routing constraints. For more information, see Texas Instruments Literature number SPRAA99 ([www.ti.com/lit/spraa99](http://www.ti.com/lit/spraa99)).

# EXAMPLE STENCIL DESIGN

ZLS0036A

NFBGA - 1.41 mm max height

BALL GRID ARRAY

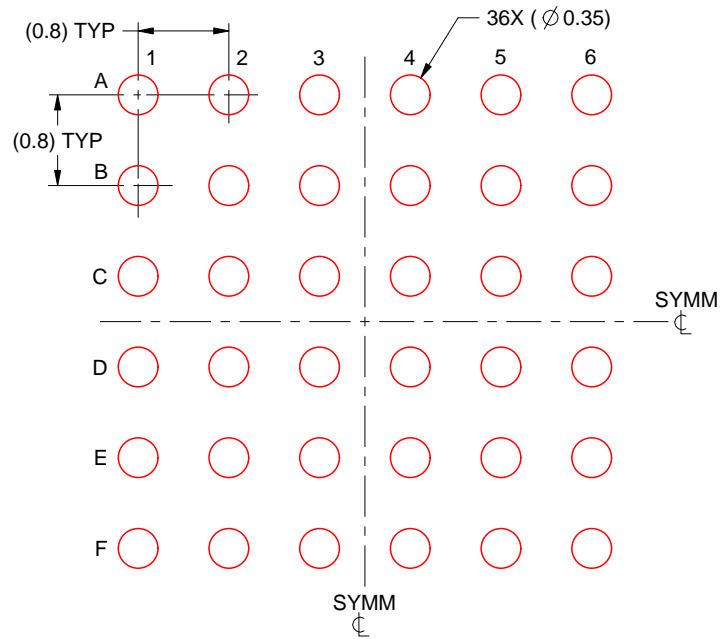

SOLDER PASTE EXAMPLE  
BASED ON 0.15 mm THICK STENCIL  
SCALE:15X

4220412/A 04/2017

NOTES: (continued)

4. Laser cutting apertures with trapezoidal walls and rounded corners may offer better paste release.

## 重要なお知らせと免責事項

TI は、技術データと信頼性データ (データシートを含みます)、設計リソース (リファレンス デザインを含みます)、アプリケーションや設計に関する各種アドバイス、Web ツール、安全性情報、その他のリソースを、欠陥が存在する可能性のある「現状のまま」提供しており、商品性および特定目的に対する適合性の黙示保証、第三者の知的財産権の非侵害保証を含むいかなる保証も、明示的または黙示的にかかわらず拒否します。

これらのリソースは、TI 製品を使用する設計の経験を積んだ開発者への提供を意図したものです。(1) お客様のアプリケーションに適した TI 製品の選定、(2) お客様のアプリケーションの設計、検証、試験、(3) お客様のアプリケーションに該当する各種規格や、その他のあらゆる安全性、セキュリティ、規制、または他の要件への確実な適合に関する責任を、お客様のみが単独で負うものとし、

上記の各種リソースは、予告なく変更される可能性があります。これらのリソースは、リソースで説明されている TI 製品を使用するアプリケーションの開発の目的でのみ、TI はその使用をお客様に許諾します。これらのリソースに関して、他の目的で複製することや掲載することは禁止されています。TI や第三者の知的財産権のライセンスが付与されている訳ではありません。お客様は、これらのリソースを自身で使用した結果発生するあらゆる申し立て、損害、費用、損失、責任について、TI およびその代理人を完全に補償するものとし、TI は一切の責任を拒否します。

TI の製品は、[TI の販売条件](#)、[TI の総合的な品質ガイドライン](#)、[ti.com](#) または TI 製品などに関連して提供される他の適用条件に従い提供されます。TI がこれらのリソースを提供することは、適用される TI の保証または他の保証の放棄の拡大や変更を意味するものではありません。TI がカスタム、またはカスタマー仕様として明示的に指定していない限り、TI の製品は標準的なカタログに掲載される汎用機器です。

お客様がいかなる追加条項または代替条項を提案する場合も、TI はそれらに異議を唱え、拒否します。

Copyright © 2026, Texas Instruments Incorporated

最終更新日 : 2025 年 10 月