

INA226 アラート搭載、36V、16 ビット、超高精度、I²C 出力電流、電圧、電力 モニタ

1 特長

- 0V~36V のバス電圧を検出
- ハイサイドまたはローサイドのセンシング
- 電流、電圧、電力を報告
- 高精度:
 - ゲイン誤差:0.1% (最大値)
 - オフセット:10μV (最大値)
- 平均化オプションを構成可能
- 16 個のプログラマブル アドレス
- 2.7V~5.5V 電源で動作
- 10 ピン DGS (VSSOP) パッケージ

2 アプリケーション

- ラック サーバー
- ワイヤレス インフラ
- 高性能コンピューティング
- パワー・マネージメント
- バッテリ セル モニタとバランサ
- 電源
- 試験装置

3 概要

INA226 は、I²C™ または SMBUS 互換インターフェイスを搭載した電流シャントおよび電力モニタです。このデバイスは、シャント電圧降下とバス電源電圧の両方を監視します。較正值、変換時間、平均化オプションをプログラム可能で、内蔵のマルチプライヤと組み合わせて電流のアンペア値や電力のワット値を直接読み出すことができます。

INA226 は、電源電圧とは無関係に、0V~36V の同相バス電圧の電流を検出できます。このデバイスは 2.7V~5.5V の単一電源で動作し、消費電流は 330μA (標準値) です。このデバイスは -40°C~125°C の動作温度範囲で動作が規定されており、I²C 互換インターフェイスで最大 16 個のアドレスをプログラム可能です。

パッケージ情報

部品番号	パッケージ (1)	パッケージ サイズ(2)
INA226	VSSOP (10)	3.00mm × 4.90 mm

- (1) 利用可能なすべてのパッケージについては、データシートの末尾にある注文情報を参照してください。
- (2) パッケージサイズ (長さ × 幅) は公称値であり、該当する場合はピンも含まれます。

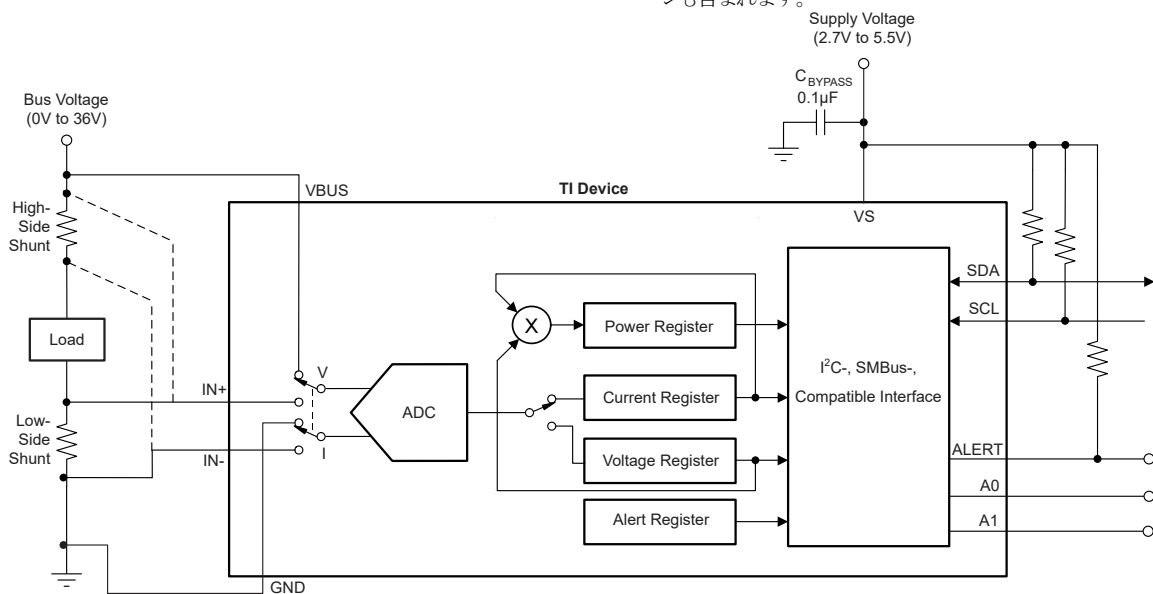

ハイサイドまたはローサイドのセンシング アプリケーション



Table of Contents

1 特長	1	7 Registers	22
2 アプリケーション	1	7.1 Register Maps.....	22
3 概要	1	8 Application and Implementation	23
4 Pin Configuration and Functions	3	8.1 Application Information.....	23
5 Specifications	4	8.2 Typical Applications.....	23
5.1 Absolute Maximum Ratings.....	4	8.3 Power Supply Recommendations.....	25
5.2 ESD Ratings.....	4	8.4 Layout.....	25
5.3 Recommended Operating Conditions.....	4	9 Device and Documentation Support	26
5.4 Thermal Information.....	4	9.1 Device Support.....	26
5.5 Electrical Characteristics.....	5	9.2 ドキュメントの更新通知を受け取る方法.....	26
5.6 Typical Characteristics.....	7	9.3 サポート・リソース.....	26
6 Detailed Description	10	9.4 Trademarks.....	26
6.1 Overview.....	10	9.5 静電気放電に関する注意事項.....	26
6.2 Functional Block Diagram.....	10	9.6 用語集.....	26
6.3 Feature Description.....	10	10 Revision History	26
6.4 Device Functional Modes.....	13	11 Mechanical, Packaging, and Orderable Information	27
6.5 Programming.....	15		

4 Pin Configuration and Functions



图 4-1. DGS Package 10-Pin VSSOP Top View

表 4-1. Pin Functions

PIN		Type	DESCRIPTION
NAME	NO.		
A0	2	Digital input	Address pin. Connect to GND, SCL, SDA, or VS. 表 6-2 shows pin settings and corresponding addresses.
A1	1	Digital input	Address pin. Connect to GND, SCL, SDA, or VS. 表 6-2 shows pin settings and corresponding addresses.
Alert	3	Digital output	Multi-functional alert, open-drain output.
GND	7	Analog	Ground.
IN+	10	Analog input	Connect to supply side of shunt resistor.
IN-	9	Analog input	Connect to load side of shunt resistor.
SCL	5	Digital input	Serial bus clock line, open-drain input.
SDA	4	Digital I/O	Serial bus data line, open-drain input/output.
VBUS	8	Analog input	Bus voltage input.
VS	6	Analog	Power supply, 2.7 V to 5.5 V.

5 Specifications

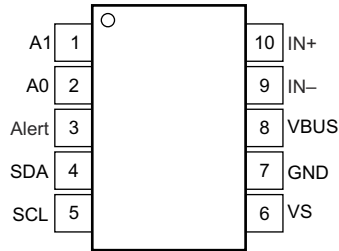
5.1 Absolute Maximum Ratings

over operating free-air temperature range (unless otherwise noted) ⁽¹⁾

		MIN	MAX	UNIT
V _{VS}	Supply voltage		6	V
Analog Inputs, IN+, IN-	Differential (V _{IN+} – V _{IN-}) ⁽²⁾	–40	40	V
	Common-Mode (V _{IN+} + V _{IN-}) / 2	–0.3	40	
V _{VBUS}		–0.3	40	V
V _{SDA}		GND – 0.3	6	V
V _{SCL}		GND – 0.3	V _{VS} + 0.3	V
I _{IN}	Input current into any pin		5	mA
I _{OUT}	Open-drain digital output current		10	mA
T _J	Junction temperature		150	°C
T _{stg}	Storage temperature range	–65	150	°C

- Operation outside the *Absolute Maximum Ratings* may cause permanent device damage. *Absolute Maximum Ratings* do not imply functional operation of the device at these or any other conditions beyond those listed under *Recommended Operating Conditions*. If used outside the *Recommended Operating Conditions* but within the *Absolute Maximum Ratings*, the device may not be fully functional, and this may affect device reliability, functionality, performance, and shorten the device lifetime.
- IN+ and IN– can have a differential voltage between –40 V and 40 V. However, the voltage at these pins must not exceed the range –0.3 V to 40 V.

5.2 ESD Ratings

			VALUE	UNIT
V _(ESD)	Electrostatic discharge	Human body model (HBM), per ANSI/ESDA/ JEDEC JS-001, all pins ⁽¹⁾	±2500	V
		Charged device model (CDM), per ANSI/ESDA/ JEDEC JS-002, all pins ⁽²⁾	±1000	

- JEDEC document JEP155 states that 500V HBM allows safe manufacturing with a standard ESD control process.
- JEDEC document JEP157 states that 250V CDM allows safe manufacturing with a standard ESD control process.

5.3 Recommended Operating Conditions

over operating free-air temperature range (unless otherwise noted)

		MIN	NOM	MAX	UNIT
V _{CM}	Common-mode input voltage		12		V
V _{VS}	Operating supply voltage		3.3		V
T _A	Operating free-air temperature	–40		125	°C

5.4 Thermal Information

THERMAL METRIC ⁽¹⁾		INA226	UNIT
		DGS (VSSOP)	
		10 PINS	
R _{θJA}	Junction-to-ambient thermal resistance	144.6	°C/W
R _{θJC(top)}	Junction-to-case (top) thermal resistance	53.3	°C/W
R _{θJB}	Junction-to-board thermal resistance	80.4	°C/W
Ψ _{JT}	Junction-to-top characterization parameter	3.5	°C/W
Υ _{JB}	Junction-to-board characterization parameter	78.9	°C/W
R _{θJC(bot)}	Junction-to-case (bottom) thermal resistance	N/A	°C/W

- For more information about traditional and new thermal metrics, see the [Semiconductor and IC Package Thermal Metrics](#) application note.

5.5 Electrical Characteristics

$T_A = 25^\circ\text{C}$, $V_{VS} = 3.3\text{ V}$, $V_{IN+} = 12\text{ V}$, $V_{SENSE} = (V_{IN+} - V_{IN-}) = 0\text{ mV}$ and $V_{VBUS} = 12\text{ V}$, unless otherwise noted

PARAMETER		TEST CONDITIONS	MIN	TYP	MAX	UNIT
INPUT						
	Shunt voltage input range		-81.9175		81.92	mV
	Bus voltage input range ⁽¹⁾		0		36	V
CMRR	Common-mode rejection	$0\text{ V} \leq V_{IN+} \leq 36\text{ V}$	126	140		dB
V_{OS}	Shunt offset voltage, RTI ⁽²⁾			±2.5	±10	µV
	Shunt offset voltage, RTI ⁽²⁾ vs temperature	$-40^\circ\text{C} \leq T_A \leq 125^\circ\text{C}$		0.02	0.1	µV/°C
PSRR	Shunt offset voltage, RTI ⁽²⁾ vs Power supply	$2.7\text{ V} \leq V_S \leq 5.5\text{ V}$		±2.5		µV/V
V_{OS}	Bus offset voltage, RTI ⁽²⁾			±1.25	±7.5	mV
	Bus offset voltage, RTI ⁽²⁾ vs temperature	$-40^\circ\text{C} \leq T_A \leq 125^\circ\text{C}$		10	40	µV/°C
PSRR	Bus offset voltage, RTI ⁽²⁾ vs power supply			±0.5		mV/V
I_B	Input bias current (I_{IN+} , I_{IN-} pins)			0.1		nA
	VBUS input impedance			830		kΩ
	Input leakage ⁽³⁾	(IN+ pin) + (IN- pin), Power-down mode		0.1	0.5	µA
DC ACCURACY						
	ADC native resolution			16		Bits
	1 LSB step size	Shunt voltage		2.5		µV
		Bus voltage		1.25		mV
	Shunt voltage gain error			0.02%	0.1%	
	Shunt voltage gain error vs temperature	$-40^\circ\text{C} \leq T_A \leq 125^\circ\text{C}$		10	50	ppm/°C
	Bus voltage gain error			0.02%	0.1%	
	Bus voltage gain error vs temperature	$-40^\circ\text{C} \leq T_A \leq 125^\circ\text{C}$		10	50	ppm/°C
	Differential nonlinearity			±0.1		LSB
t_{CT}	ADC conversion time	CT bit = 000		140	154	µs
		CT bit = 001		204	224	
		CT bit = 010		332	365	
		CT bit = 011		588	646	
		CT bit = 100		1.1	1.21	ms
		CT bit = 101		2.116	2.328	
		CT bit = 110		4.156	4.572	
		CT bit = 111		8.244	9.068	
SMBus						
	SMBus timeout ⁽⁴⁾			28	35	ms
DIGITAL INPUT/OUTPUT						
	Input capacitance			3		pF
	Leakage input current	$0\text{ V} \leq V_{SCL} \leq V_{VS}$, $0\text{ V} \leq V_{SDA} \leq V_{VS}$, $0\text{ V} \leq V_{Alert} \leq V_{VS}$, $0\text{ V} \leq V_{A0} \leq V_{VS}$, $0\text{ V} \leq V_{A1} \leq V_{VS}$		0.1	1	µA
V_{IH}	High-level input voltage		$0.7 \times V_{VS}$		6	V
V_{IL}	Low-level input voltage		-0.5		$0.3 \times V_{VS}$	V
V_{OL}	Low-level output voltage, SDA, Alert	$I_{OL} = 3\text{ mA}$	0		0.4	V
	Hysteresis			500		mV
POWER SUPPLY						
	Operating supply range		2.7		5.5	V
I_Q	Quiescent current			330	420	µA
	Quiescent current, power-down (shutdown) mode			0.5	2	µA

$T_A = 25^\circ\text{C}$, $V_{VS} = 3.3\text{ V}$, $V_{IN+} = 12\text{ V}$, $V_{SENSE} = (V_{IN+} - V_{IN-}) = 0\text{ mV}$ and $V_{VBUS} = 12\text{ V}$, unless otherwise noted

PARAMETER		TEST CONDITIONS	MIN	TYP	MAX	UNIT
V_{POR}	Power-on reset threshold			2		V

- (1) While the input range is 36 V, the full-scale range of the ADC scaling is 40.96 V. See the [セクション 6.3.1](#). Do not apply more than 36 V.
- (2) RTI = Referred-to-input.
- (3) Input leakage is positive (current flowing into the pin) for the conditions shown at the top of this table. Negative leakage currents can occur under different input conditions.
- (4) SMBus timeout in the device resets the interface any time SCL is low for more than 28 ms.

5.6 Typical Characteristics

At $T_A = 25^\circ\text{C}$, $V_{VS} = 3.3\text{ V}$, $V_{IN+} = 12\text{ V}$, $V_{SENSE} = (V_{IN+} - V_{IN-}) = 0\text{ mV}$ and $V_{VBUS} = 12\text{ V}$, unless otherwise noted.

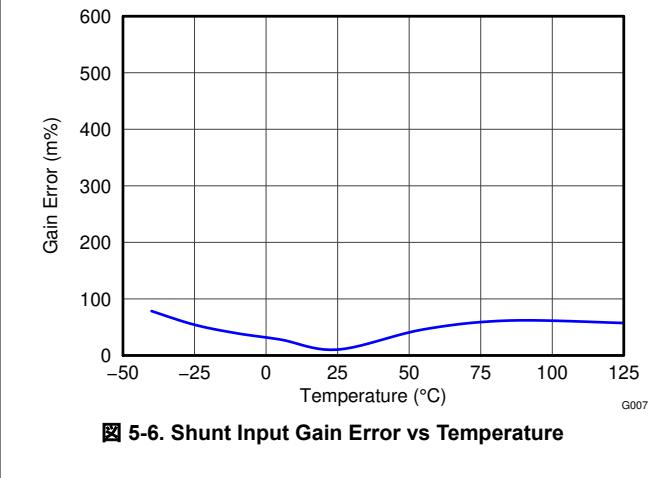
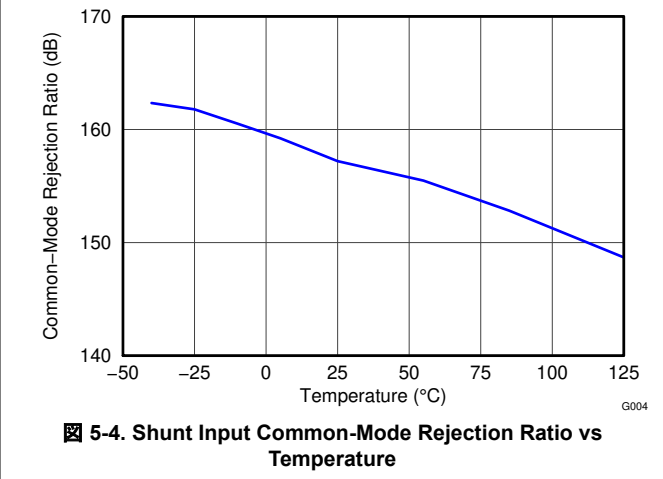
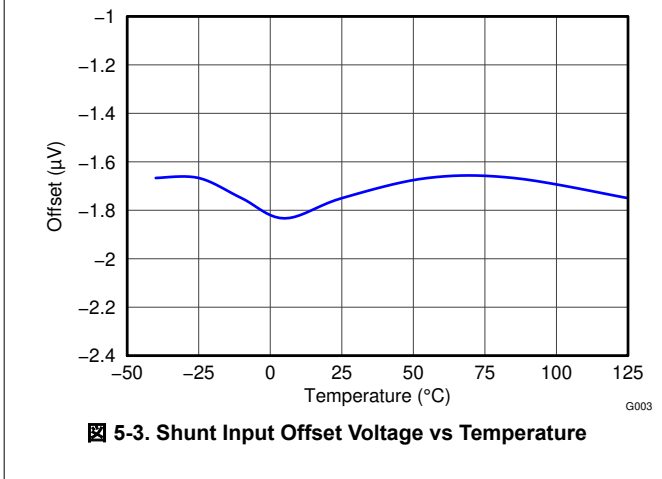
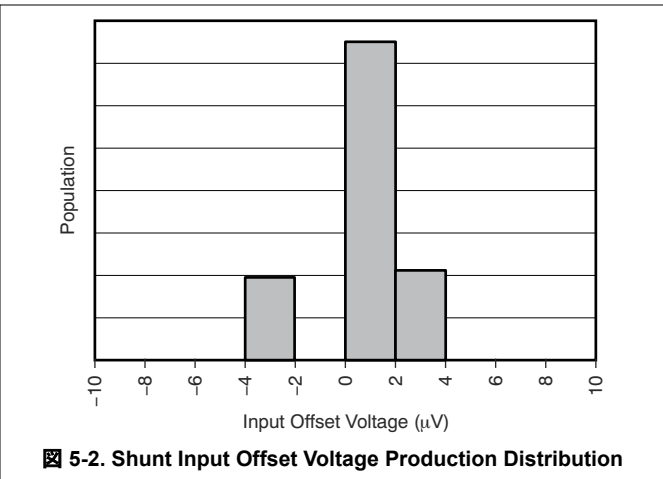
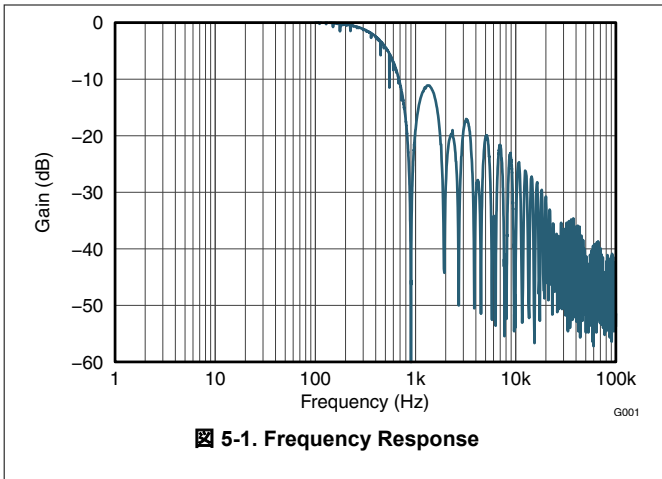

5.6 Typical Characteristics (continued)

At $T_A = 25^\circ\text{C}$, $V_{VS} = 3.3\text{ V}$, $V_{IN+} = 12\text{ V}$, $V_{SENSE} = (V_{IN+} - V_{IN-}) = 0\text{ mV}$ and $V_{VBUS} = 12\text{ V}$, unless otherwise noted.

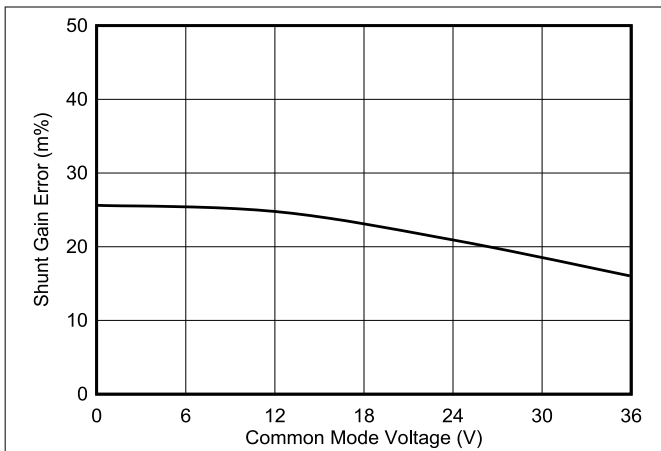

Figure 5-7. Shunt Input Gain Error vs Common-Mode Voltage

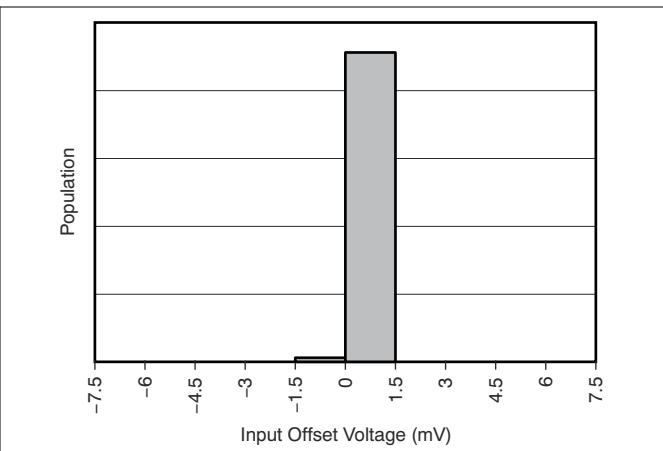

Figure 5-8. Bus Input Offset Voltage Production Distribution

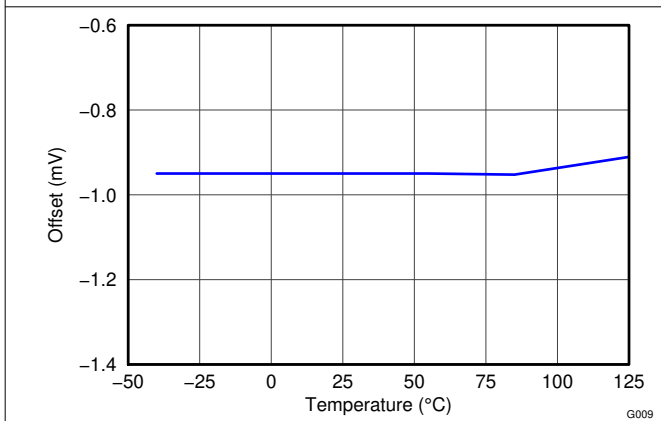

Figure 5-9. Bus Input Offset Voltage vs Temperature

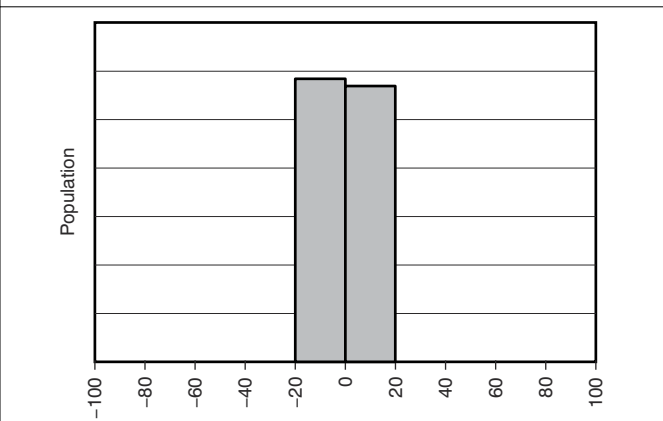

Figure 5-10. Bus Input Gain Error Production Distribution

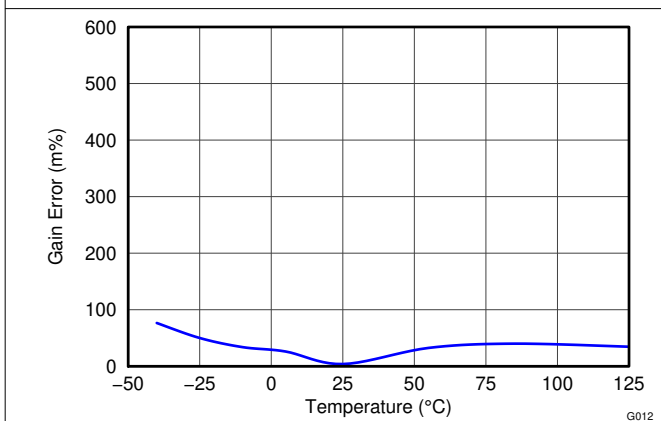

Figure 5-11. Bus Input Gain Error vs Temperature

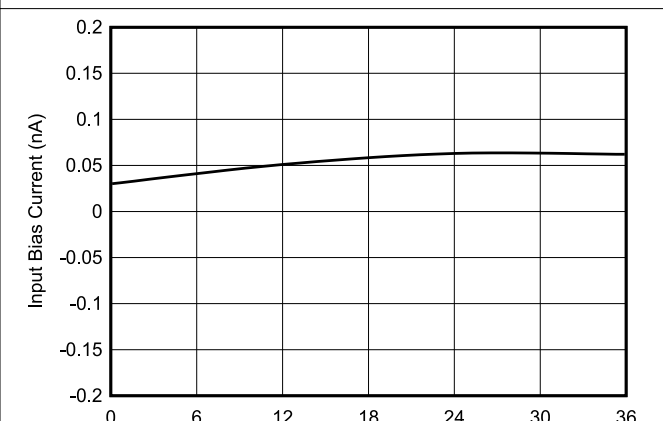

Figure 5-12. Input Bias Current vs Common-Mode Voltage

5.6 Typical Characteristics (continued)

At $T_A = 25^\circ\text{C}$, $V_{VS} = 3.3\text{ V}$, $V_{IN+} = 12\text{ V}$, $V_{SENSE} = (V_{IN+} - V_{IN-}) = 0\text{ mV}$ and $V_{VBUS} = 12\text{ V}$, unless otherwise noted.

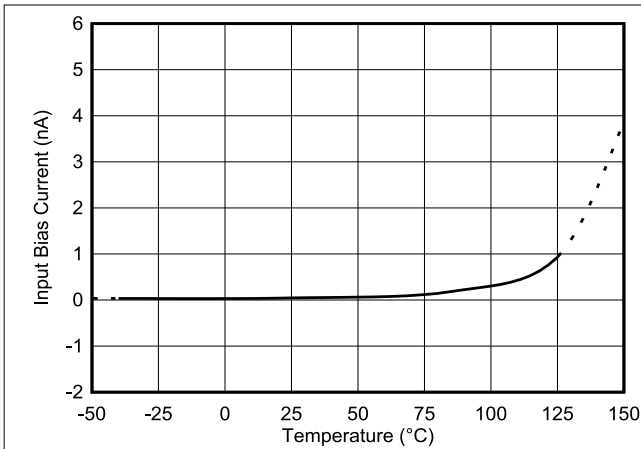

FIG 5-13. Input Bias Current vs Temperature

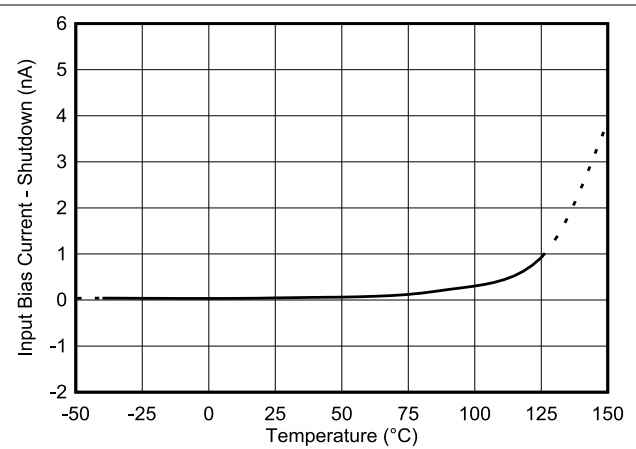

FIG 5-14. Input Bias Current vs Temperature, Shutdown

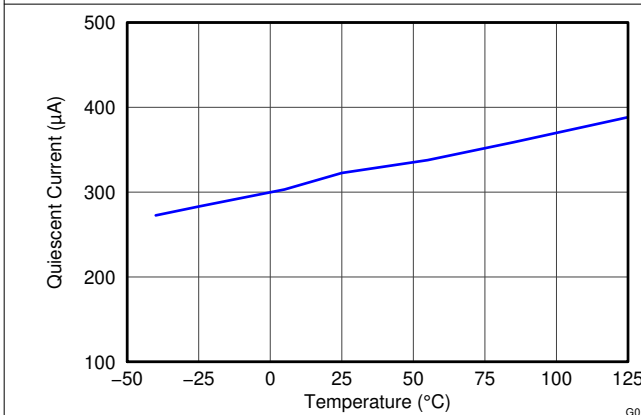

FIG 5-15. Active I_Q vs Temperature

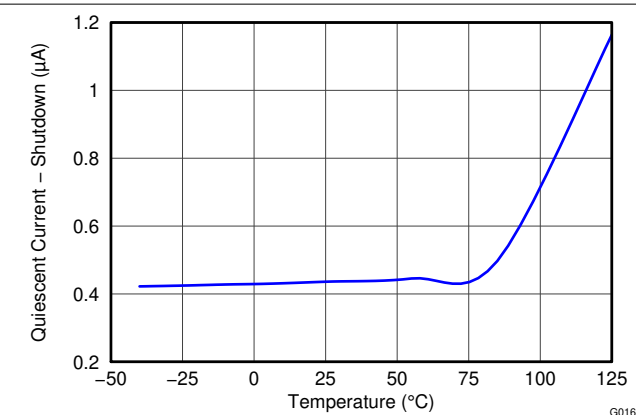

FIG 5-16. Shutdown I_Q vs Temperature

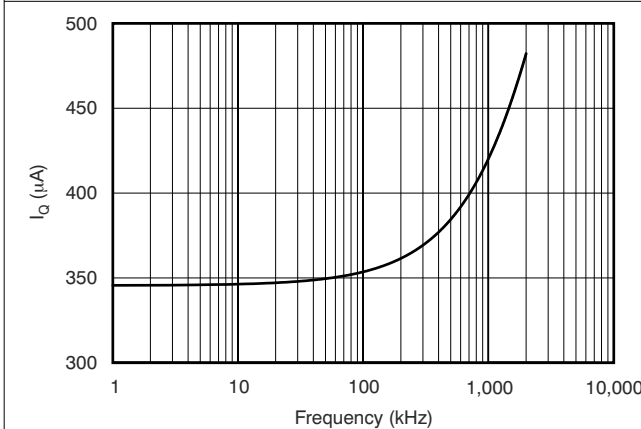

FIG 5-17. Active I_Q vs I^2C Clock Frequency

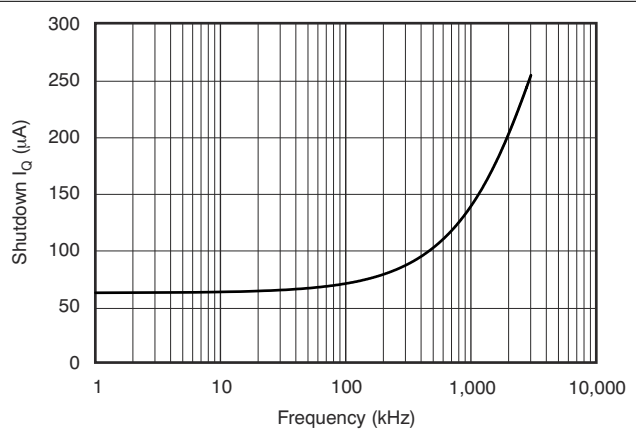

FIG 5-18. Shutdown I_Q vs I^2C Clock Frequency

6 Detailed Description

6.1 Overview

The INA226 is a digital current sense amplifier with an I²C- and SMBus-compatible interface. The device provides digital current, voltage, and power readings necessary for accurate decision-making in precisely-controlled systems. Programmable registers allow flexible configuration for measurement resolution as well as continuous-versus-triggered operation. Detailed register information appears at the end of this data sheet. See the [Functional Block Diagram](#) section for a block diagram of the INA226 device.

6.2 Functional Block Diagram

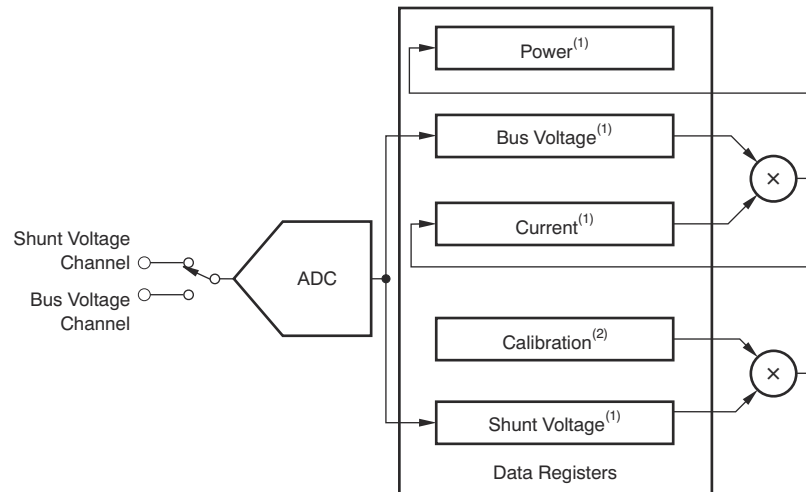

(1) Read-only

(2) Read/write

6.3 Feature Description

6.3.1 Basic ADC Functions

The INA226 device performs two measurements on the power-supply bus of interest. The voltage developed from the load current that flows through a shunt resistor creates a shunt voltage that is measured at the IN+ and IN– pins. The device can also measure the power supply bus voltage by connecting this voltage to the VBUS pin. The differential shunt voltage is measured with respect to the IN– pin while the bus voltage is measured with respect to ground.

The device is typically powered by a separate supply that can range from 2.7 V to 5.5 V. The bus that is being monitored can range in voltage from 0 V to 36 V. Based on the fixed 1.25-mV LSB for the Bus Voltage Register that a full-scale register results in a 40.96 V value.

注

Do not apply more than 36 V of actual voltage to the input pins.

There are no special considerations for power-supply sequencing because the common-mode input range and power-supply voltage are independent of each other; therefore, the bus voltage can be present with the supply voltage off, and reciprocally.

The device takes two measurements, shunt voltage and bus voltage. The device then converts these measurements to current, based on the Calibration Register value, and then calculates power. Refer to the [Programming the Calibration Register](#) section for additional information on programming the Calibration Register.

The device has two operating modes, continuous and triggered, that determine how the ADC operates following these conversions. When the device is in the normal operating mode (that is, MODE bits of the Configuration Register (00h) are set to '111'), the device continuously converts a shunt voltage reading followed by a bus voltage reading. After the shunt voltage reading, the current value is calculated (based on 式 3). This current value is then used to calculate the power result (using 式 4). These values are subsequently stored in an accumulator, and the measurement/calculation sequence repeats until the number of averages set in the Configuration Register (00h) is reached. Following every sequence, the present set of values measured and calculated are appended to previously collected values. After all of the averaging has been completed, the final values for shunt voltage, bus voltage, current, and power are updated in the corresponding registers that can then be read. These values remain in the data output registers until the values are replaced by the next fully completed conversion results. Reading the data output registers does not affect a conversion in progress.

The mode control in the Conversion Register (00h) also permits selecting modes to convert only the shunt voltage or the bus voltage to further allow the user to configure the monitoring function to fit the specific application requirements.

All current and power calculations are performed in the background and do not contribute to conversion time.

In triggered mode, writing any of the triggered convert modes into the Configuration Register (00h) (that is, MODE bits of the Configuration Register (00h) are set to '001', '010', or '011') triggers a single-shot conversion. This action produces a single set of measurements; thus, to trigger another single-shot conversion, the Configuration Register (00h) must be written to a second time, even if the mode does not change.

In addition to the two operating modes (continuous and triggered), the device also has a power-down mode that reduces the quiescent current and turns off current into the device inputs, reducing the impact of supply drain when the device is not being used. Full recovery from power-down mode requires 40µs. The registers of the device can be written to and read from while the device is in power-down mode. The device remains in power-down mode until one of the active modes settings are written into the Configuration Register (00h).

Although the device can be read at any time, and the data from the last conversion remain available, the Conversion Ready flag bit (Mask/Enable Register, CVRF bit) is provided to help coordinate one-shot or triggered conversions. The Conversion Ready flag (CVRF) bit is set after all conversions, averaging, and multiplication operations are complete.

The Conversion Ready flag (CVRF) bit clears under these conditions:

- Writing to the Configuration Register (00h), except when configuring the MODE bits for power-down mode; or
- Reading the Mask/Enable Register (06h)

6.3.1.1 Power Calculation

The Current and Power are calculated following shunt voltage and bus voltage measurements as shown in [Figure 6-1](#). Current is calculated following a shunt voltage measurement based on the value set in the Calibration Register. If there is no value loaded into the Calibration Register, the current value stored is zero. Power is calculated following the bus voltage measurement based on the previous current calculation and bus voltage measurement. If there is no value loaded in the Calibration Register, the power value stored is also zero. Again, these calculations are performed in the background and do not add to the overall conversion time. These current and power values are considered intermediate results (unless the averaging is set to 1) and are stored in an internal accumulation register, not the corresponding output registers. Following every measured sample, the newly-calculated values for current and power are appended to this accumulation register until all of the samples have been measured and averaged based on the number of averages set in the Configuration Register (00h).



図 6-1. Power Calculation Scheme

In addition to the current and power accumulating after every sample, the shunt and bus voltage measurements are also collected. After all of the samples have been measured and the corresponding current and power calculations have been made, the accumulated average for each of these parameters is then loaded to the corresponding output registers, where the average can then be read.

6.3.1.2 Alert Pin

The INA226 has a single Alert Limit Register (07h), that allows the Alert pin to be programmed to respond to a single user-defined event or to a Conversion Ready notification if desired. The Mask/Enable Register allows the user to select from one of the five available functions to monitor and/or set the Conversion Ready bit to control the response of the Alert pin. Based on the function being monitored, the user then enters a value into the Alert Limit Register to set the corresponding threshold value that asserts the Alert pin.

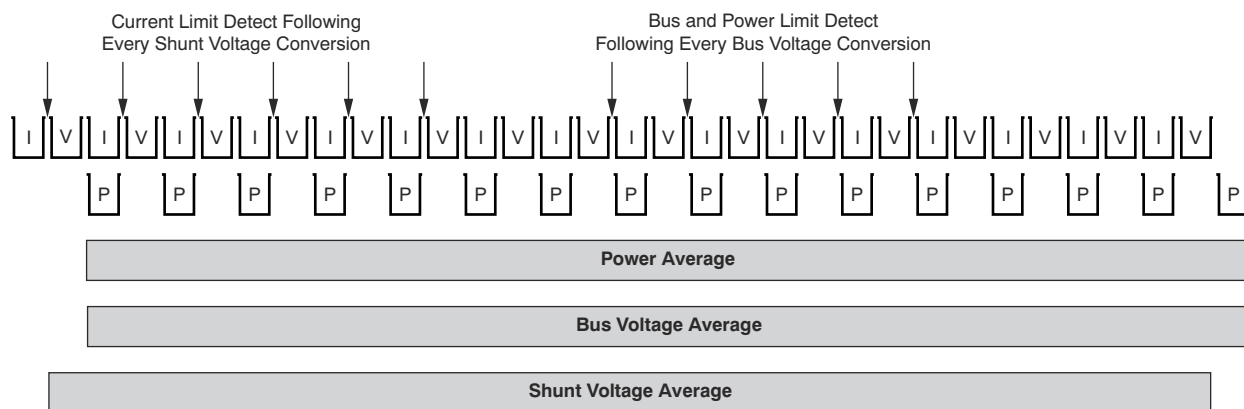
The Alert pin allows for one of several available alert functions to be monitored to determine if a user-defined threshold has been exceeded. The five alert functions that can be monitored are:

- Shunt Voltage Over-Limit (SOL)
- Shunt Voltage Under-Limit (SUL)
- Bus Voltage Over-Limit (BOL)
- Bus Voltage Under-Limit (BUL)
- Power Over-Limit (POL)

The Alert pin is an open-drain output. This pin is asserted when the alert function selected in the Mask/Enable Register exceeds the value programmed into the Alert Limit Register. Only one of these alert functions can be enabled and monitored at a time. If multiple alert functions are enabled, the selected function in the highest significant bit position takes priority and responds to the Alert Limit Register value. For example, if the Shunt Voltage Over-Limit function and the Shunt Voltage Under-Limit function are both selected, the Alert pin asserts when the Shunt Voltage Register exceeds the value in the Alert Limit Register.

The Conversion Ready state of the device can also be monitored at the Alert pin to inform the user when the device has completed the previous conversion and is ready to begin a new conversion. Conversion Ready can be monitored at the Alert pin along with one of the alert functions. If an alert function and the Conversion Ready are both enabled to be monitored at the Alert pin, after the Alert pin is asserted, the Mask/Enable Register must be read following the alert to determine the source of the alert. By reading the Conversion Ready Flag (CVRF, bit 3), and the Alert Function Flag (AFF, bit 4) in the Mask/Enable Register, the source of the alert can be determined. If the Conversion Ready feature is not desired and the CNVR bit is not set, the Alert pin only responds to an exceeded alert limit based on the alert function enabled.

If the alert function is not used, the Alert pin can be left floating without impacting the operation of the device.

Refer to [图 6-1](#) to see the relative timing of when the value in the Alert Limit Register is compared to the corresponding converted value. For example, if the alert function that is enabled is Shunt Voltage Over-Limit (SOL), following every shunt voltage conversion the value in the Alert Limit Register is compared to the

measured shunt voltage to determine if the measurements has exceeded the programmed limit. The AFF, bit 4 of the Mask/Enable Register, asserts high any time the measured voltage exceeds the value programmed into the Alert Limit Register. In addition to the AFF being asserted, the Alert pin is asserted based on the Alert Polarity Bit (APOL, bit 1 of the Mask/Enable Register). If the Alert Latch is enabled, the AFF and Alert pin remain asserted until either the Configuration Register (00h) is written to or the Mask/Enable Register is read.

The Bus Voltage alert functions compare the measured bus voltage to the Alert Limit Register following every bus voltage conversion and assert the AFF bit and Alert pin if the limit threshold is exceeded.

The Power Over-Limit alert function is also compared to the calculated power value following every bus voltage measurement conversion and asserts the AFF bit and Alert pin if the limit threshold is exceeded.

6.4 Device Functional Modes

6.4.1 Averaging and Conversion Time Considerations

The INA226 device offers programmable conversion times (t_{CT}) for both the shunt voltage and bus voltage measurements. The conversion times for these measurements can be selected from as fast as 140 μ s to as long as 8.244 ms. The conversion time settings, along with the programmable averaging mode, allow the device to be configured to optimize the available timing requirements in a given application. For example, if a system requires that data be read every 5ms, the device can be configured with the conversion times set to 588 μ s for both shunt and bus voltage measurements and the averaging mode set to 4. This configuration results in the data updating approximately every 4.7ms. The device can also be configured with a different conversion time setting for the shunt and bus voltage measurements. This type of approach is common in applications where the bus voltage tends to be relatively stable. This situation can allow for the time focused on the bus voltage measurement to be reduced relative to the shunt voltage measurement. The shunt voltage conversion time can be set to 4.156 ms with the bus voltage conversion time set to 588 μ s, with the averaging mode set to 1. This configuration also results in data updating approximately every 4.7 ms.

There are trade-offs associated with the settings for conversion time and the averaging mode used. The averaging feature can significantly improve the measurement accuracy by effectively filtering the signal. This approach allows the device to reduce any noise in the measurement that can be caused by noise coupling into the signal. A greater number of averages enables the device to be more effective in reducing the noise component of the measurement.

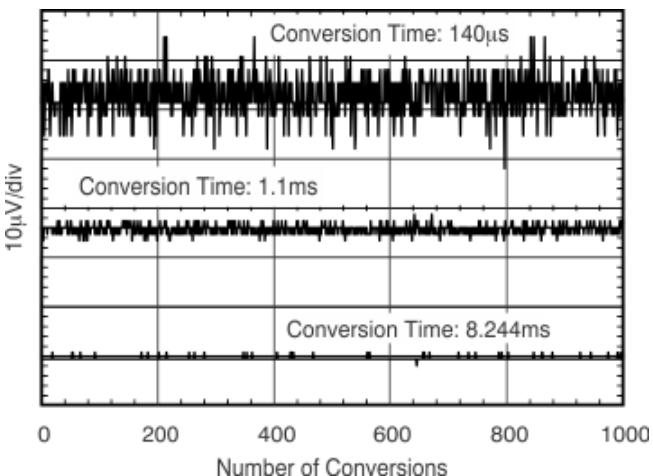
The conversion times selected can also have an impact on the measurement accuracy.  shows multiple conversion times to illustrate the impact of noise on the measurement. to achieve the highest accuracy measurement possible, use a combination of the longest allowable conversion times and highest number of averages, based on the timing requirements of the system.



図 6-2. Noise vs Conversion Time

6.4.2 Filtering and Input Considerations

Measuring current is often noisy, and such noise can be difficult to define. The INA226 device offers several options for filtering by allowing the conversion times and number of averages to be selected independently in the Configuration Register (00h). The conversion times can be set independently for the shunt voltage and bus voltage measurements to allow added flexibility in configuring the monitoring of the power-supply bus.

The internal ADC is based on a delta-sigma ($\Delta\Sigma$) front-end with a 500 kHz ($\pm 30\%$) typical sampling rate. This architecture has good inherent noise rejection; however, transients that occur at or very close to the sampling rate harmonics can cause problems. Because these signals are at 1 MHz and higher, the signals can be managed by incorporating filtering at the input of the device. The high frequency enables the use of low-value series resistors on the filter with negligible effects on measurement accuracy. In general, filtering the device input is only necessary if there are transients at exact harmonics of the 500 kHz ($\pm 30\%$) sampling rate (greater than 1 MHz). Filter using the lowest possible series resistance (typically 10 Ω or less) and a ceramic capacitor. Recommended values for this capacitor are between 0.1 μF and 1 μF .  6-3 shows the device with a filter added at the input.

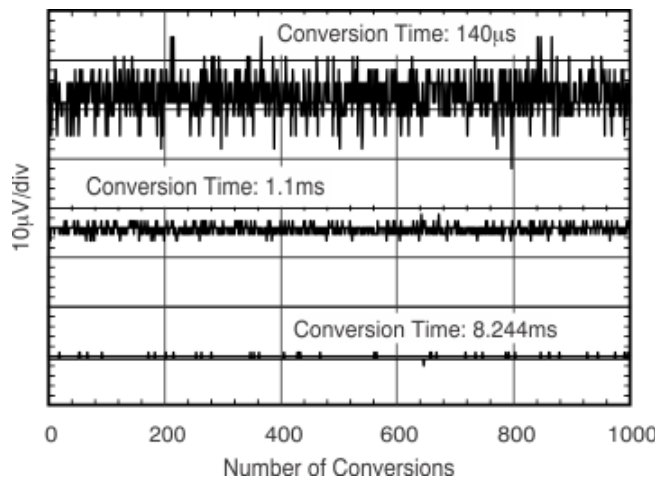
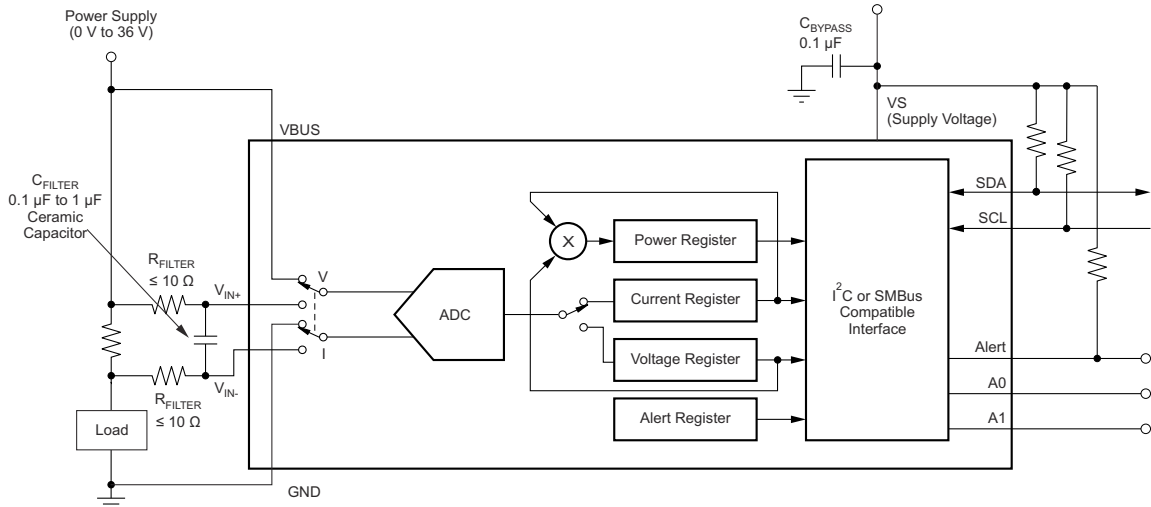
Overload conditions are another consideration for the device inputs. The device inputs are specified to tolerate 40 V across the inputs. A large differential scenario can be a short to ground on the load side of the shunt. This type of event can result in full power-supply voltage across the shunt (as long the power supply or energy storage capacitors support the voltage). Removing a short to ground can result in inductive kickbacks that can exceed the 40-V differential and common-mode rating of the device. Inductive kickback voltages are best controlled by Zener-type transient-absorbing devices (commonly called *transzorb*s) combined with sufficient energy storage capacitance. See the TI Design, *Transient Robustness for Current Shunt Monitors (TIDU473)*, which describes a high-side current shunt monitor used to measure the voltage developed across a current-sensing resistor when current passes through the resistor.

In applications that do not have large energy storage electrolytics on one or both sides of the shunt, an input overstress condition can result from an excessive dV/dt of the voltage applied to the input. A hard physical short is the most likely cause of this event, particularly in applications with no large electrolytics present. This problem occurs because an excessive dV/dt can activate the ESD protection in the device in systems where large currents are available. Testing demonstrates that the addition of 10- Ω resistors in series with each input of the device sufficiently protects the inputs against this dV/dt failure up to the 40-V rating of the device. Selecting these resistors in the range noted has minimal effect on accuracy.



図 6-3. Input Filtering

6.5 Programming

An important aspect of the INA226 is that the device does not necessarily measure current or power. The device measures both the differential voltage applied between the IN+ and IN- input pins and the voltage applied to the VBUS pin. For the device to report both current and power values, the user must program the resolution of the Current Register (04h) and the value of the shunt resistor present in the application to develop the differential voltage applied between the input pins. The Power Register (03h) is internally set to be 25 times the programmed Current_LSB. Both the Current_LSB and shunt resistor value are used in the calculation of the Calibration Register value the device uses to calculate the corresponding current and power values based on the measured shunt and bus voltages.

The Calibration Register is calculated based on 式 1. This equation includes the term Current_LSB, which is the programmed value for the LSB for the Current Register (04h). The user uses this value to convert the value in the Current Register (04h) to the actual current in amperes. The highest resolution for the Current Register (04h) can be obtained by using the smallest allowable Current_LSB based on the maximum expected current as shown in 式 2. While this value yields the highest resolution, selecting a value for the Current_LSB to the nearest round number above this value is common to simplify the conversion of the Current Register (04h) and Power Register (03h) to amperes and watts respectively. The R_{SHUNT} term is the value of the external shunt used to develop the differential voltage across the input pins.

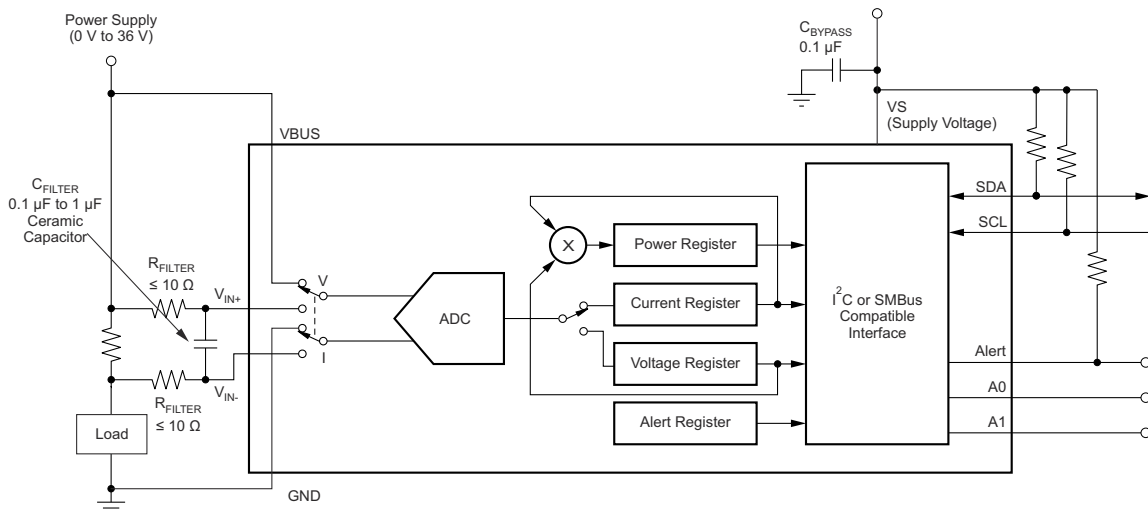
$$CAL = \frac{0.00512}{Current_LSB \times R_{SHUNT}} \quad (1)$$

where

- 0.00512 is an internal fixed value used to verify scaling is maintained properly

$$Current_LSB = \frac{Maximum\ Expected\ Current}{2^{15}} \quad (2)$$

After programming the Calibration Register, the Current Register (04h) and Power Register (03h) update accordingly based on the corresponding shunt voltage and bus voltage measurements. Until the Calibration Register is programmed, the Current Register (04h) and Power Register (03h) remain at zero.

6.5.1 Programming the Calibration Register

☒ 8-1 shows a nominal 10-A load that creates a differential voltage of 20 mV across a 2-mΩ shunt resistor. The bus voltage for the INA226 is measured at the external VBUS input pin, which in this example is connected to the IN- pin to measure the voltage level delivered to the load. For this example, the VBUS pin measures less than 12 V because the voltage at the IN- pin is 11.98 V as a result of the voltage drop across the shunt resistor.

For this example, assuming a maximum expected current of 15 A, the Current_LSB is calculated to be 457.7 μA/bit using 式 2. Using a value for the Current_LSB of 500 μA/Bit or 1 mA/Bit significantly simplifies the conversion from the Current Register (04h) and Power Register (03h) to amperes and watts. For this example, a value of 1 mA/bit is selected for the Current_LSB. Using this value for the Current_LSB does trade a small amount of resolution for having a simpler conversion process on the user side. Using 式 1 in this example with a Current_LSB value of 1 mA/bit and a shunt resistor of 2 mΩ results in a Calibration Register value of 2560, or A00h.

The Current Register (04h) is then calculated by multiplying the decimal value of the Shunt Voltage Register (01h) contents by the decimal value of the Calibration Register and then dividing by 2048, as shown in 式 3. For this example, the Shunt Voltage Register contains a value of 8,000 (representing 20 mV), which is multiplied by the Calibration Register value of 2560 and then divided by 2048 to yield a decimal value for the Current Register (04h) of 10000, or 2710h. Multiplying this value by 1 mA/bit results in the original 10-A level stated in the example.

$$Current = \frac{ShuntVoltage \times CalibrationRegister}{2048} \quad (3)$$

The LSB for the Bus Voltage Register (02h) is a fixed 1.25 mV/bit, which means that the 11.98 V present at the VBUS pin results in a register value of 2570h, or a decimal equivalent of 9584. Note that the MSB of the Bus Voltage Register (02h) is always zero because the VBUS pin is only able to measure positive voltages.

The Power Register (03h) is then be calculated by multiplying the decimal value of the Current Register, 10000, by the decimal value of the Bus Voltage Register (02h), 9584, and then dividing by 20,000, as defined in 式 4. For this example, the result for the Power Register (03h) is 12B8h, or a decimal equivalent of 4792. Multiplying this result by the power LSB (25 times the $[1 \times 10^{-3} \text{ Current_LSB}]$) results in a power calculation of $(4792 \times 25 \text{ mW/bit})$, or 119.82 W. The power LSB has a fixed ratio to the Current_LSB of 25. For this example, a programmed 1 mA/bit Current_LSB results in a power LSB of 25 mW/bit. This ratio is internally programmed to verify that the scaling of the power calculation is within an acceptable range. A manual calculation for the power being delivered to the load uses a bus voltage of 11.98 V ($12 V_{CM} - 20 \text{ mV shunt drop}$) multiplied by the load current of 10 A to give a result of 119.8 W.

$$\text{Power} = \frac{\text{Current} \times \text{BusVoltage}}{20000} \quad (4)$$

表 6-1 lists the steps for configuring, measuring, and calculating the values for current and power for this device.

表 6-1. Calculating Current and Power

STEP	REGISTER NAME	ADDRESS	CONTENTS	DEC	LSB	VALUE ⁽¹⁾
Step 1	Configuration Register	00h	4127h	—	—	—
Step 2	Shunt Register	01h	1F40h	8000	2.5 μ V	20 mV
Step 3	Bus Voltage Register	02h	2570h	9584	1.25 mV	11.98 V
Step 4	Calibration Register	05h	A00h	2560	—	—
Step 5	Current Register	04h	2710	10000	1 mA	10 A
Step 6	Power Register	03h	12B8h	4792	25 mW	119.82 W

(1) Conditions: Load = 10 A, $V_{CM} = 12 \text{ V}$, $R_{SHUNT} = 2 \text{ m}\Omega$, and $V_{VBUS} = 12 \text{ V}$.

6.5.2 Programming the Power Measurement Engine

6.5.2.1 Calibration Register and Scaling

The Calibration Register enables the user to scale the Current Register (04h) and Power Register (03h) to the most useful value for a given application. For example, set the Calibration Register such that the largest possible number is generated in the Current Register (04h) or Power Register (03h) at the expected full-scale point. This approach yields the highest resolution using the previously calculated minimum Current_LSB in the equation for the Calibration Register. The Calibration Register can also be selected to provide values in the Current Register (04h) and Power Register (03h) that either provide direct decimal equivalents of the values being measured, or yield a round LSB value for each corresponding register. After these choices are made, the Calibration Register also offers possibilities for end user system-level calibration. After determining the exact current by using an external ammeter, the value of the Calibration Register can then be adjusted based on the measured current result of the INA226 to cancel the total system error as shown in 式 5.

$$\text{Corrected_Full_Scale_Cal} = \text{trunc} \left[\frac{\text{Cal} \times \text{MeasShuntCurrent}}{\text{Device_Current}} \right] \quad (5)$$

6.5.3 Simple Current Shunt Monitor Usage (No Programming Necessary)

The device can be used without any programming if reading a shunt voltage drop and bus voltage with the default power-on reset configuration and continuous conversion of shunt and bus voltages is only necessary.

Without programming the device Calibration Register, the device is unable to provide either a valid current or power value, because these outputs are both derived using the values loaded into the Calibration Register.

6.5.4 Default Settings

The default power-up states of the registers are shown in the [Register Maps](#) section of this data sheet. These registers are volatile, and if programmed to a value other than the default values shown in [表 7-1](#), the registers must be re-programmed at every device power-up. Detailed information on programming the Calibration Register specifically is given in the [Programming](#) section and calculated based on [式 1](#).

6.5.5 Bus Overview

The INA226 offers compatibility with both I²C and SMBus interfaces. The I²C and SMBus protocols are essentially compatible with one another.

The I²C interface is used throughout this data sheet as the primary example, with SMBus protocol specified only when a difference between the two systems is discussed. Two lines, SCL and SDA, connect the device to the bus. Both SCL and SDA are open-drain connections.

The device that initiates a data transfer is called a *master*, and the devices controlled by the master are *slaves*. The bus must be controlled by a master device that generates the serial clock (SCL), controls the bus access, and generates START and STOP conditions.

To address a specific device, the master initiates a start condition by pulling the data signal line (SDA) from a high to a low logic level while SCL is high. All slaves on the bus shift in the slave address byte on the rising edge of SCL, with the last bit indicating whether a read or write operation is intended. During the ninth clock pulse, the slave being addressed responds to the master by generating an Acknowledge and pulling SDA low.

Data transfer is then initiated and eight bits of data are sent, followed by an *Acknowledge* bit. During data transfer, SDA must remain stable while SCL is high. Any change in SDA while SCL is high is interpreted as a start or stop condition.

After all data have been transferred, the master generates a stop condition, indicated by pulling SDA from low to high while SCL is high. The device includes a 28 ms timeout on the interface to prevent locking up the bus.

6.5.5.1 Serial Bus Address

To communicate with the INA226, the master must first address slave devices via a slave address byte. The slave address byte consists of seven address bits and a direction bit that indicates whether the action is to be a read or write operation.

The device has two address pins, A0 and A1. 表 6-2 lists the pin logic levels for each of the 16 possible addresses. The device samples the state of pins A0 and A1 on every bus communication. Establish the pin states before any activity on the interface occurs.

表 6-2. Address Pins and Slave Addresses

A1	A0	SLAVE ADDRESS
GND	GND	1000000
GND	VS	1000001
GND	SDA	1000010
GND	SCL	1000011
VS	GND	1000100
VS	VS	1000101
VS	SDA	1000110
VS	SCL	1000111
SDA	GND	1001000
SDA	VS	1001001
SDA	SDA	1001010
SDA	SCL	1001011
SCL	GND	1001100
SCL	VS	1001101
SCL	SDA	1001110
SCL	SCL	1001111

6.5.5.2 Serial Interface

The INA226 operates only as a slave device on both the I²C bus and the SMBus. Connections to the bus are made using the open-drain SDA and SCL lines. The SDA and SCL pins feature integrated spike suppression filters and Schmitt triggers to minimize the effects of input spikes and bus noise. Although the device integrates spike suppression into the digital I/O lines, proper layout techniques help minimize the amount of coupling into the communication lines. This noise introduction can occur from capacitively coupling signal edges between the two communication lines themselves or from other switching noise sources present in the system. Routing traces in parallel with ground in between layers on a printed circuit board (PCB) typically reduces the effects of coupling between the communication lines. Shielded communication lines reduces the possibility of unintended noise coupling into the digital I/O lines that can be incorrectly interpreted as start or stop commands.

The INA226 supports the transmission protocol for fast mode (1 kHz to 400 kHz) and high-speed mode (1 kHz to 2.94 MHz). All data bytes are transmitted most significant byte first.

6.5.5.3 Writing to and Reading From the INA226

Accessing a specific register on the INA226 is accomplished by writing the appropriate value to the register pointer. Refer to 表 7-1 for a complete list of registers and corresponding addresses. The value for the register pointer (as shown in 図 6-7) is the first byte transferred after the slave address byte with the R/ \bar{W} bit low. Every write operation to the device requires a value for the register pointer.

Writing to a register begins with the first byte transmitted by the master. This byte is the slave address, with the R/ \bar{W} bit low. The device then acknowledges receipt of a valid address. The next byte transmitted by the master is the address of the register which data is written to. This register address value updates the register pointer to the desired register. The next two bytes are written to the register addressed by the register pointer. The device

acknowledges receipt of each data byte. The master can terminate data transfer by generating a start or stop condition.

When reading from the device, the last value stored in the register pointer by a write operation determines which register is read during a read operation. To change the register pointer for a read operation, a new value must be written to the register pointer. This write is accomplished by issuing a slave address byte with the R/\bar{W} bit low, followed by the register pointer byte. No additional data are required. The master then generates a start condition and sends the slave address byte with the R/\bar{W} bit high to initiate the read command. The next byte is transmitted by the slave and is the most significant byte of the register indicated by the register pointer. This byte is followed by an *Acknowledge* from the master; then the slave transmits the least significant byte. The master acknowledges receipt of the data byte. The master can terminate data transfer by generating a *Not-Acknowledge* after receiving any data byte, or generating a start or stop condition. If repeated reads from the same register are desired, continually sending the register pointer bytes is not necessary; the device retains the register pointer value until the value is changed by the next write operation.

☒ 6-4 shows the write operation timing diagram. ☒ 6-5 shows the read operation timing diagram.

注

Register bytes are sent most-significant byte first, followed by the least significant byte.

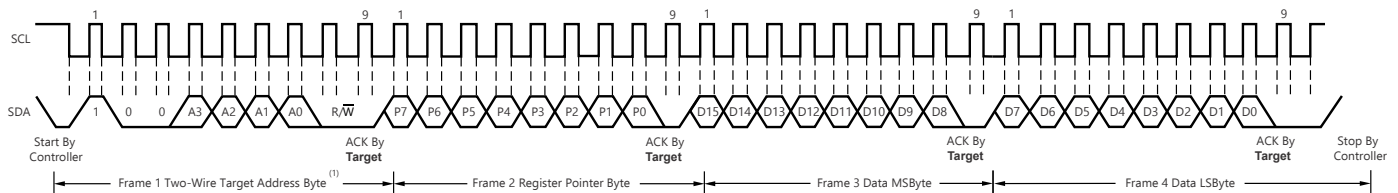

1. The value of the Slave Address byte is determined by the settings of the A0 and A1 pins. Refer to 表 6-2.

☒ 6-4. Timing Diagram for Write Word Format

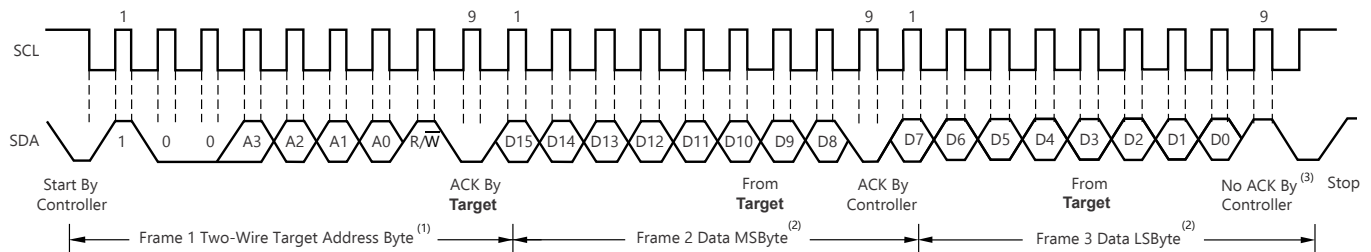

1. The value of the Slave Address byte is determined by the settings of the A0 and A1 pins. Refer to 表 6-2.
2. Read data is from the last register pointer location. If a new register is desired, the register pointer must be updated. See ☒ 6-7.
3. ACK by Master can also be sent.

☒ 6-5. Timing Diagram for Read Word Format

☒ 6-6 shows the timing diagram for the SMBus Alert response operation. ☒ 6-7 illustrates a typical register pointer configuration.

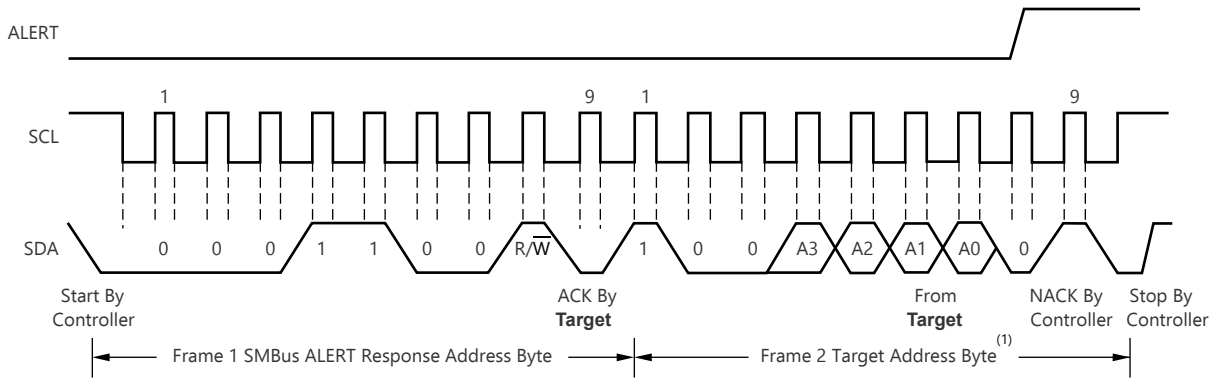

1. The value of the Slave Address Byte is determined by the settings of the A0 and A1 pins. Refer to 表 6-2.

図 6-6. Timing Diagram for SMBus ALERT

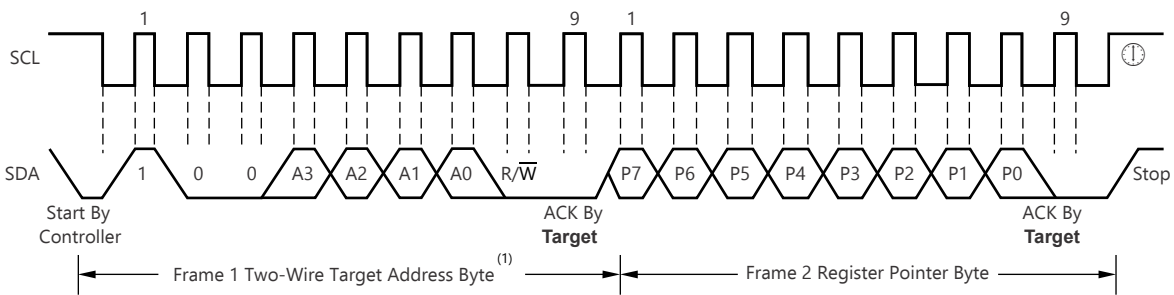

1. The value of the Slave Address Byte is determined by the settings of the A0 and A1 pins. Refer to 表 6-2.

図 6-7. Typical Register Pointer Set

6.5.5.3.1 High-Speed I²C Mode

When the bus is idle, both the SDA and SCL lines are pulled high by the pullup resistors. The master generates a start condition followed by a valid serial byte containing high-speed (HS) master code 00001XXX. This transmission is made in fast (400 kHz) or standard (100 kHz) (F/S) mode at no more than 400 kHz. The device does not acknowledge the HS master code, but does recognize the code and switches the internal filters to support 2.94 MHz operation.

The master then generates a repeated start condition (a repeated start condition has the same timing as the start condition). After this repeated start condition, the protocol is the same as F/S mode, except that transmission speeds up to 2.94 MHz are allowed. Instead of using a stop condition, use repeated start conditions to secure the bus in HS-mode. A stop condition ends the HS-mode and switches all the internal filters of the device to support the F/S mode.



図 6-8. Bus Timing Diagram

表 6-3. Bus Timing Diagram Definitions ⁽¹⁾

PARAMETER		FAST MODE		HIGH-SPEED MODE		UNIT
		MIN	MAX	MIN	MAX	
SCL operating frequency	$f_{(SCL)}$	0.001	0.4	0.001	2.94	MHz
Bus free time between stop and start conditions	$t_{(BUF)}$	600		160		ns
Hold time after repeated START condition. After this period, the first clock is generated.	$t_{(HDSTA)}$	100		100		ns
Repeated start condition setup time	$t_{(SUSTA)}$	100		100		ns
STOP condition setup time	$t_{(SUSTO)}$	100		100		ns
Data hold time	$t_{(HDDAT)}$	10	900	10	100	ns
Data setup time	$t_{(SUDAT)}$	100		20		ns
SCL clock low period	$t_{(LOW)}$	1300		200		ns
SCL clock high period	$t_{(HIGH)}$	600		60		ns
Data fall time	t_F		300		80	ns
Clock fall time	t_F		300		40	ns
Clock rise time	t_R		300		40	ns
Clock/data rise time for SCLK \leq 100kHz	t_R		1000			ns

(1) Values based on a statistical analysis of a one-time sample of devices. Minimum and maximum values are not guaranteed and not production tested.

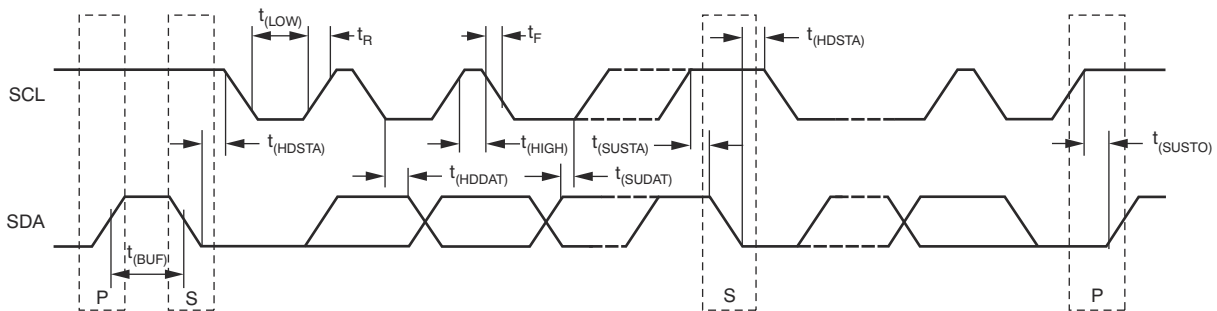
6.5.5.4 SMBus Alert Response

The INA226 is designed to respond to the SMBus Alert Response address. The SMBus Alert Response provides a quick fault identification for simple slave devices. When an Alert occurs, the master can broadcast the Alert Response slave address (0001 100) with the Read/Write bit set high. Following this Alert Response, any slave device that generates an alert identifies the slave device by acknowledging the Alert Response and sending the address on the bus.

The Alert Response can activate several different slave devices simultaneously, similar to the I²C General Call. If more than one slave attempts to respond, bus arbitration rules apply. The losing device does not generate an Acknowledge and continues to hold the Alert line low until the interrupt is cleared.

7 Registers

7.1 Register Maps

The INA226 uses a bank of registers for holding configuration settings, measurement results, minimum/maximum limits, and status information. 表 7-1 summarizes the device registers; refer to the [Functional Block Diagram](#) section for an illustration of the registers.

All 16-bit device registers are two 8-bit bytes via the I²C interface.

表 7-1. Register Set Summary

POINTER ADDRESS	REGISTER NAME	FUNCTION	POWER-ON RESET		TYPE ⁽¹⁾
			BINARY	HEX	
00h	Configuration Register	All-register reset, shunt voltage and bus voltage ADC conversion times and averaging, operating mode.	01000001 00100111	4127	R/ \bar{W}
01h	Shunt Voltage Register	Shunt voltage measurement data.	00000000 00000000	0000	R
02h	Bus Voltage Register	Bus voltage measurement data.	00000000 00000000	0000	R
03h	Power Register ⁽²⁾	Contains the value of the calculated power being delivered to the load.	00000000 00000000	0000	R
04h	Current Register ⁽²⁾	Contains the value of the calculated current flowing through the shunt resistor.	00000000 00000000	0000	R
05h	Calibration Register	Sets full-scale range and LSB of current and power measurements. Overall system calibration.	00000000 00000000	0000	R/ \bar{W}
06h	Mask/Enable Register	Alert configuration and Conversion Ready flag.	00000000 00000000	0000	R/ \bar{W}
07h	Alert Limit Register	Contains the limit value to compare to the selected Alert function.	00000000 00000000	0000	R/ \bar{W}
FEh	Manufacturer ID Register	Contains unique manufacturer identification number.	0101010001001001	5449	R
FFh	Die ID Register	Contains unique die identification number.	0010001001100000	2260	R

(1) Type: **R** = Read-Only, **R/ \bar{W}** = Read/Write.

(2) The Current Register (04h) and Power Register (03h) default to '0' because the Calibration register defaults to '0', yielding zero current and power values until the Calibration register is programmed.

8 Application and Implementation

注

以下のアプリケーション情報は、TI の製品仕様に含まれるものではなく、TI ではその正確性または完全性を保証いたしません。個々の目的に対する製品の適合性については、お客様の責任で判断していただくこととなります。お客様は自身の設計実装を検証しテストすることで、システムの機能を確認する必要があります。

8.1 Application Information

The INA226 is a current shunt and power monitor with an I²C™ compatible interface. The device monitors both a shunt voltage drop and bus supply voltage. Programmable calibration value, conversion times, and averaging, combined with an internal multiplier, enable direct readouts of current in amperes and power in watts.

8.2 Typical Applications

8.2.1 High-Side Sensing Circuit Application



図 8-1. Typical Circuit Configuration, INA226

8.2.1.1 Design Requirements

INA226 measures the voltage developed across a current-sensing resistor (R_{SHUNT}) when current passes through the resistor. The device also measures the bus supply voltage and can calculate power when calibrated. The device comes with alert capability where the alert pin can be programmed to respond to a user-defined event or to a conversion ready notification. This design illustrates the ability of the alert pin to respond to a set threshold.

8.2.1.2 Detailed Design Procedure

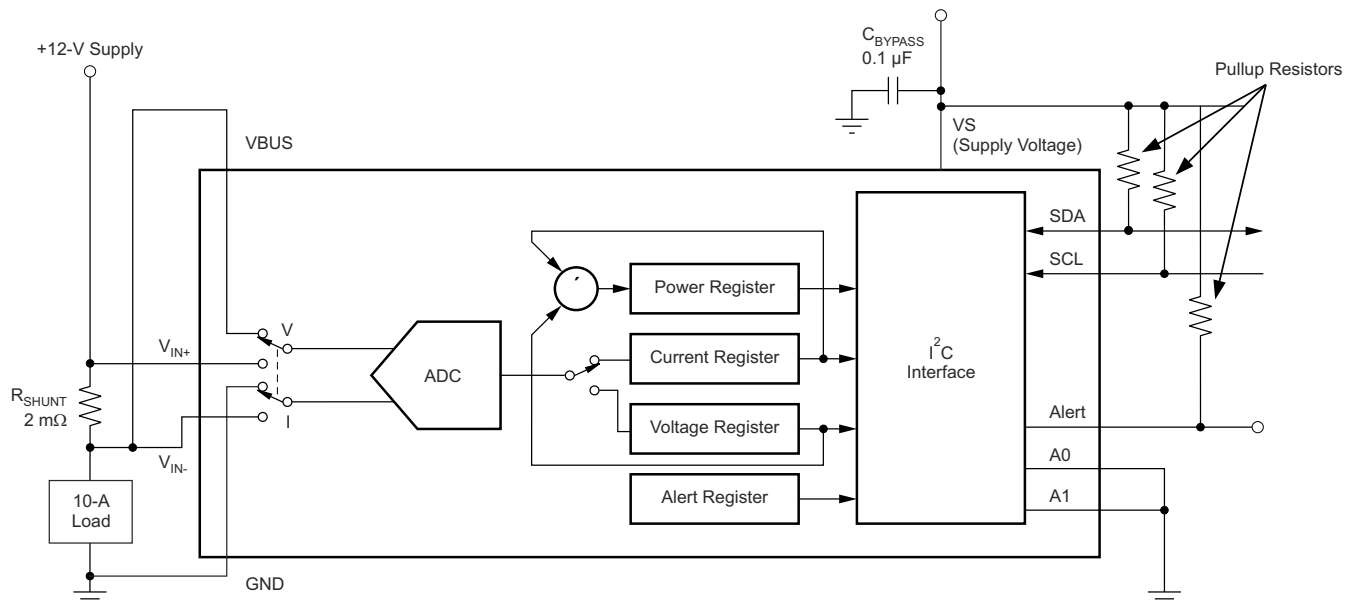
The Alert pin can be configured to respond to one of the five alert functions described in the [Alert Pin](#) section. The alert pin must be pulled up to the V_{VS} pin voltage via the pull-up resistors. The configuration register is set based on the required conversion time and averaging. The Mask/Enable Register is set to identify the required alert function and the Alert Limit Register is set to the limit value used for comparison.

8.2.1.3 Application Curves

☒ 8-2 shows the Alert pin response to a shunt voltage over-limit of 80 mV for a conversion time (t_{CT}) of 1.1 ms and averaging set to 1. ☒ 8-3 shows the response for the same limit but with the conversion time reduced to 140 μ s.



表 8-1. Configuration Register (00h) Settings for ☒ 8-2 (Value = 4025h)

BIT #	D15	D14	D13	D12	D11	D10	D9	D8	D7	D6	D5	D4	D3	D2	D1	D0
BIT NAME	RST	—	—	—	AVG2	AVG1	AVG0	VBUSCT ₂	VBUSCT ₁	VBUSCT ₀	V _{SH} CT2	V _{SH} CT1	V _{SH} CT0	MODE3	MODE2	MODE1
POR VALUE	0	1	0	0	0	0	0	0	0	0	1	0	0	1	0	1

表 8-2. Configuration Register (00h) Settings for ☒ 8-3 (Value = 4005h)

BIT #	D15	D14	D13	D12	D11	D10	D9	D8	D7	D6	D5	D4	D3	D2	D1	D0
BIT NAME	RST	—	—	—	AVG2	AVG1	AVG0	VBUSCT ₂	VBUSCT ₁	VBUSCT ₀	V _{SH} CT2	V _{SH} CT1	V _{SH} CT0	MODE3	MODE2	MODE1
POR VALUE	0	1	0	0	0	0	0	0	0	0	0	0	0	1	0	1

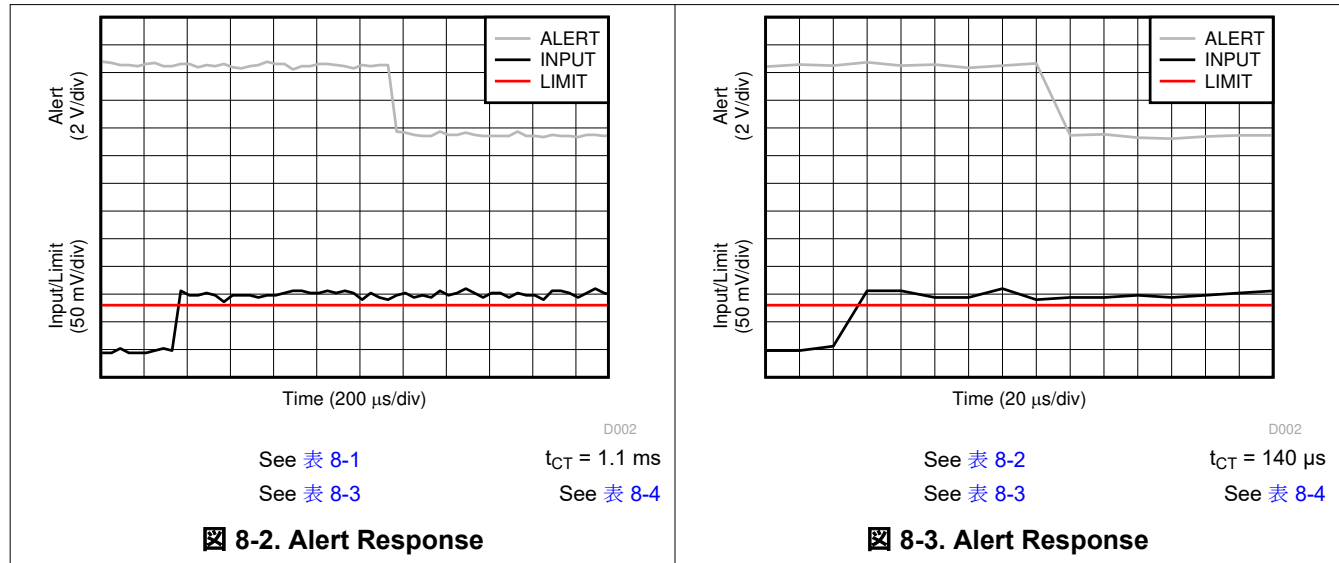
表 8-3. Mask/Enable Register (06h) Settings for ☒ 8-2 and ☒ 8-3 (Value = 8000h)

BIT #	D15	D14	D13	D12	D11	D10	D9	D8	D7	D6	D5	D4	D3	D2	D1	D0
BIT NAME	SOL	SUL	BOL	BUL	POL	CNVR	—	—	—	—	—	AFF	CVRF	OVF	APOL	LEN
POR VALUE	1	0	0	0	0	0	0	0	0	0	0	0	0	0	0	0

表 8-4. Alert Limit Register (07h) Settings for ☒ 8-2 and ☒ 8-3 (Value = 7D00)

BIT #	D15	D14	D13	D12	D11	D10	D9	D8	D7	D6	D5	D4	D3	D2	D1	D0
BIT NAME	AUL15	AUL14	AUL13	AUL12	AUL11	AUL10	AUL9	AUL8	AUL7	AUL6	AUL5	AUL4	AUL3	AUL2	AUL1	AUL0
POR VALUE	0	1	1	1	1	1	0	1	0	0	0	0	0	0	0	

8.3 Power Supply Recommendations

The input circuitry of the device can accurately measure signals on common-mode voltages beyond the power supply voltage, V_{VS} . For example, the voltage applied to the V_{VS} power supply terminal can be 5 V, whereas the load power-supply voltage being monitored (the common-mode voltage) can be as high as 36 V. Note also that the device can withstand the full 0-V to 36-V range at the input terminals, regardless of whether the device has power applied or not.

Place the required power-supply bypass capacitors as close as possible to the supply and ground terminals of the device to provide stability. A typical value for this supply bypass capacitor is 0.1 μ F. Applications with noisy or high-impedance power supplies can require additional decoupling capacitors to reject power-supply noise.

8.4 Layout

8.4.1 Layout Guidelines

Connect the input pins (IN+ and IN-) to the sensing resistor using a Kelvin connection or a 4-wire connection. These connection techniques verify that only the current-sensing resistor impedance is detected between the input pins. Poor routing of the current-sensing resistor commonly results in additional resistance present between the input pins. Given the very low ohmic value of the current-sensing resistor, any additional high-current carrying impedance causes significant measurement errors. Place the power-supply bypass capacitor as close as possible to the supply and ground pins.

8.4.2 Layout Example

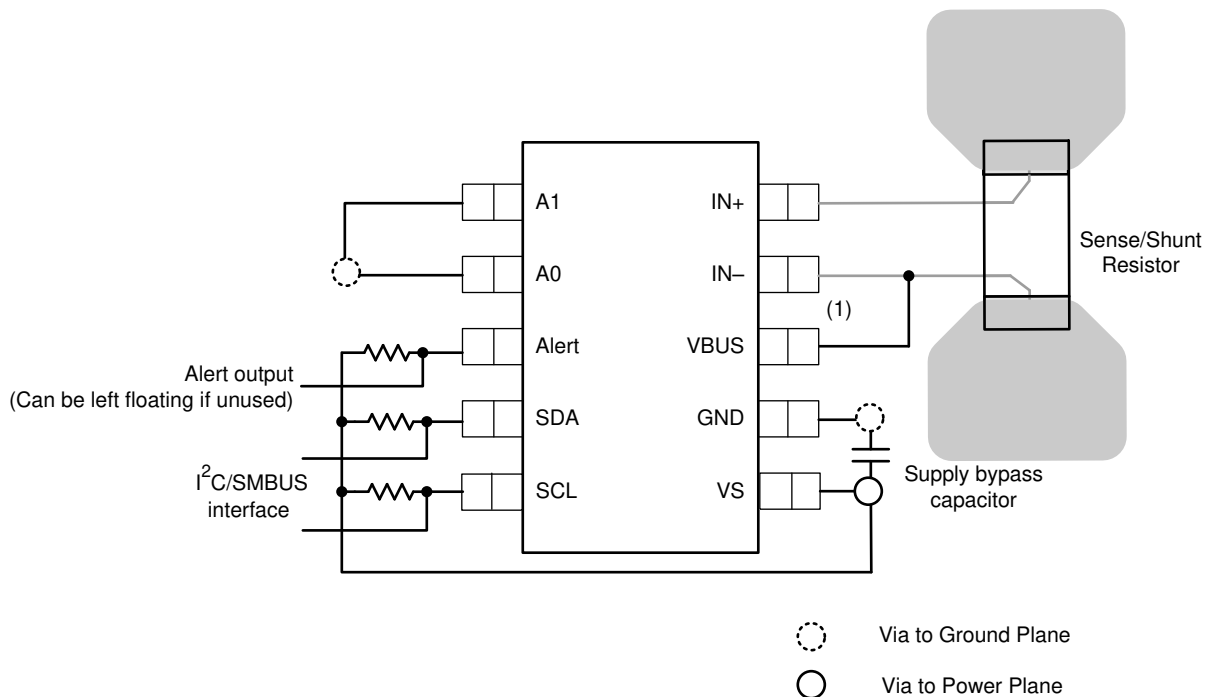

(1) connect the VBUS pin to the power supply rail.

8-4. INA226 Layout Example

9 Device and Documentation Support

9.1 Device Support

9.1.1 Development Support

- INA226EVM Evaluation Board and Software Tutorial ([SBOU113](#))

9.2 ドキュメントの更新通知を受け取る方法

ドキュメントの更新についての通知を受け取るには、www.tij.co.jp のデバイス製品フォルダを開いてください。[通知] をクリックして登録すると、変更されたすべての製品情報に関するダイジェストを毎週受け取ることができます。変更の詳細については、改訂されたドキュメントに含まれている改訂履歴をご覧ください。

9.3 サポート・リソース

テキサス・インスツルメンツ E2E™ サポート・フォーラムは、エンジニアが検証済みの回答と設計に関するヒントをエキスパートから迅速かつ直接得ることができる場所です。既存の回答を検索したり、独自の質問をしたりすることで、設計に必要な支援を迅速に得ることができます。

リンクされているコンテンツは、各寄稿者により「現状のまま」提供されるものです。これらはテキサス・インスツルメンツの仕様を構成するものではなく、必ずしもテキサス・インスツルメンツの見解を反映したものではありません。テキサス・インスツルメンツの[使用条件](#)を参照してください。

9.4 Trademarks

I2C™ is a trademark of I2C Technologies, Ltd.

テキサス・インスツルメンツ E2E™ is a trademark of Texas Instruments.

すべての商標は、それぞれの所有者に帰属します。

9.5 静電気放電に関する注意事項



この IC は、ESD によって破損する可能性があります。テキサス・インスツルメンツは、IC を取り扱う際には常に適切な注意を払うことを推奨します。正しい取り扱いおよび設置手順に従わない場合、デバイスを破損するおそれがあります。

ESD による破損は、わずかな性能低下からデバイスの完全な故障まで多岐にわたります。精密な IC の場合、パラメータがわずかに変化するだけで公表されている仕様から外れる可能性があるため、破損が発生しやすくなっています。

9.6 用語集

[テキサス・インスツルメンツ用語集](#) この用語集には、用語や略語の一覧および定義が記載されています。

10 Revision History

資料番号末尾の英字は改訂を表しています。その改訂履歴は英語版に準じています。

Changes from Revision A (August 2015) to Revision B (September 2024)	Page
ドキュメント全体にわたって表、図、相互参照の採番方法を更新。.....	1
Removed Machine Model from ESD Ratings.....	4
Updated thermal metric values to match thermal model.....	4
Added ± in front of typical values for PSRR specifications.....	5
Decreased input bias current typical value.....	5
Updated <i>Shunt Input Gain Error vs Common-Mode Voltage</i> graph and Input Bias current curves.....	7

Changes from Revision * (June 2011) to Revision A (August 2015)	Page
「取り扱い定格」の表、「機能説明」セクション、「デバイスの機能モード」セクション、「アプリケーションと実装」セクション、「電源に関する推奨事項」セクション、「レイアウト」セクション、「デバイスおよびドキュメントのサポート」セクション、「メカニカル、パッケージ、および注文情報」セクションを追加。.....	1

11 Mechanical, Packaging, and Orderable Information

The following pages include mechanical, packaging, and orderable information. This information is the most current data available for the designated devices. This data is subject to change without notice and revision of this document. For browser-based versions of this data sheet, refer to the left-hand navigation.

重要なお知らせと免責事項

テキサス・インスツルメンツは、技術データと信頼性データ (データシートを含みます)、設計リソース (リファレンス デザインを含みます)、アプリケーションや設計に関する各種アドバイス、Web ツール、安全性情報、その他のリソースを、欠陥が存在する可能性のある「現状のまま」提供しており、商品性および特定目的に対する適合性の黙示保証、第三者の知的財産権の非侵害保証を含むいかなる保証も、明示的または黙示的にかかわらず拒否します。

これらのリソースは、テキサス・インスツルメンツ製品を使用する設計の経験を積んだ開発者への提供を意図したものです。(1) お客様のアプリケーションに適した テキサス・インスツルメンツ製品の選定、(2) お客様のアプリケーションの設計、検証、試験、(3) お客様のアプリケーションに該当する各種規格や、その他のあらゆる安全性、セキュリティ、規制、または他の要件への確実な適合に関する責任を、お客様のみが単独で負うものとします。

上記の各種リソースは、予告なく変更される可能性があります。これらのリソースは、リソースで説明されている テキサス・インスツルメンツ製品を使用するアプリケーションの開発の目的でのみ、テキサス・インスツルメンツはその使用をお客様に許諾します。これらのリソースに関して、他の目的で複製することや掲載することは禁止されています。テキサス・インスツルメンツや第三者の知的財産権のライセンスが付与されている訳ではありません。お客様は、これらのリソースを自身で使用した結果発生するあらゆる申し立て、損害、費用、損失、責任について、テキサス・インスツルメンツおよびその代理人を完全に補償するものとし、テキサス・インスツルメンツは一切の責任を拒否します。

テキサス・インスツルメンツの製品は、[テキサス・インスツルメンツの販売条件](#)、または [ti.com](https://www.ti.com) やかかる テキサス・インスツルメンツ製品の関連資料などのいずれかを通じて提供する適用可能な条項の下で提供されています。テキサス・インスツルメンツがこれらのリソースを提供することは、適用されるテキサス・インスツルメンツの保証または他の保証の放棄の拡大や変更を意味するものではありません。

お客様がいかなる追加条項または代替条項を提案した場合でも、テキサス・インスツルメンツはそれらに異議を唱え、拒否します。

郵送先住所: Texas Instruments, Post Office Box 655303, Dallas, Texas 75265

Copyright © 2024, Texas Instruments Incorporated

PACKAGING INFORMATION

Orderable part number	Status (1)	Material type (2)	Package Pins	Package qty Carrier	RoHS (3)	Lead finish/ Ball material (4)	MSL rating/ Peak reflow (5)	Op temp (°C)	Part marking (6)
INA226AIDGSR	Active	Production	VSSOP (DGS) 10	2500 LARGE T&R	Yes	NIPDAU SN NIPDAUAG	Level-2-260C-1 YEAR	-40 to 125	226
INA226AIDGSR.A	Active	Production	VSSOP (DGS) 10	2500 LARGE T&R	Yes	NIPDAU	Level-2-260C-1 YEAR	-40 to 125	226
INA226AIDGSR.B	Active	Production	VSSOP (DGS) 10	2500 LARGE T&R	Yes	NIPDAU	Level-2-260C-1 YEAR	-40 to 125	226
INA226AIDGSRG4	Active	Production	VSSOP (DGS) 10	2500 LARGE T&R	Yes	NIPDAU	Level-1-260C-UNLIM	-40 to 125	226
INA226AIDGSRG4.A	Active	Production	VSSOP (DGS) 10	2500 LARGE T&R	Yes	NIPDAU	Level-1-260C-UNLIM	-40 to 125	226
INA226AIDGSRG4.B	Active	Production	VSSOP (DGS) 10	2500 LARGE T&R	Yes	NIPDAU	Level-1-260C-UNLIM	-40 to 125	226
INA226AIDGST	Active	Production	VSSOP (DGS) 10	250 SMALL T&R	Yes	NIPDAU SN NIPDAUAG	Level-2-260C-1 YEAR	-40 to 125	226
INA226AIDGST.A	Active	Production	VSSOP (DGS) 10	250 SMALL T&R	Yes	SN	Level-2-260C-1 YEAR	-40 to 125	226
INA226AIDGST.B	Active	Production	VSSOP (DGS) 10	250 SMALL T&R	Yes	SN	Level-2-260C-1 YEAR	-40 to 125	226

(1) **Status:** For more details on status, see our [product life cycle](#).

(2) **Material type:** When designated, preproduction parts are prototypes/experimental devices, and are not yet approved or released for full production. Testing and final process, including without limitation quality assurance, reliability performance testing, and/or process qualification, may not yet be complete, and this item is subject to further changes or possible discontinuation. If available for ordering, purchases will be subject to an additional waiver at checkout, and are intended for early internal evaluation purposes only. These items are sold without warranties of any kind.

(3) **RoHS values:** Yes, No, RoHS Exempt. See the [TI RoHS Statement](#) for additional information and value definition.

(4) **Lead finish/Ball material:** Parts may have multiple material finish options. Finish options are separated by a vertical ruled line. Lead finish/Ball material values may wrap to two lines if the finish value exceeds the maximum column width.

(5) **MSL rating/Peak reflow:** The moisture sensitivity level ratings and peak solder (reflow) temperatures. In the event that a part has multiple moisture sensitivity ratings, only the lowest level per JEDEC standards is shown. Refer to the shipping label for the actual reflow temperature that will be used to mount the part to the printed circuit board.

(6) **Part marking:** There may be an additional marking, which relates to the logo, the lot trace code information, or the environmental category of the part.

Multiple part markings will be inside parentheses. Only one part marking contained in parentheses and separated by a "~" will appear on a part. If a line is indented then it is a continuation of the previous line and the two combined represent the entire part marking for that device.

Important Information and Disclaimer: The information provided on this page represents TI's knowledge and belief as of the date that it is provided. TI bases its knowledge and belief on information provided by third parties, and makes no representation or warranty as to the accuracy of such information. Efforts are underway to better integrate information from third parties. TI has taken and continues to take reasonable steps to provide representative and accurate information but may not have conducted destructive testing or chemical analysis on incoming materials and chemicals. TI and TI suppliers consider certain information to be proprietary, and thus CAS numbers and other limited information may not be available for release.

In no event shall TI's liability arising out of such information exceed the total purchase price of the TI part(s) at issue in this document sold by TI to Customer on an annual basis.

OTHER QUALIFIED VERSIONS OF INA226 :

- Automotive : [INA226-Q1](#)

NOTE: Qualified Version Definitions:

- Automotive - Q100 devices qualified for high-reliability automotive applications targeting zero defects

TAPE AND REEL INFORMATION

QUADRANT ASSIGNMENTS FOR PIN 1 ORIENTATION IN TAPE

*All dimensions are nominal

Device	Package Type	Package Drawing	Pins	SPQ	Reel Diameter (mm)	Reel Width W1 (mm)	A0 (mm)	B0 (mm)	K0 (mm)	P1 (mm)	W (mm)	Pin1 Quadrant
INA226AIDGSR	VSSOP	DGS	10	2500	330.0	12.4	5.3	3.4	1.4	8.0	12.0	Q1
INA226AIDGSR	VSSOP	DGS	10	2500	330.0	12.4	5.25	3.35	1.25	8.0	12.0	Q1
INA226AIDGSR	VSSOP	DGS	10	2500	330.0	12.4	5.3	3.4	1.4	8.0	12.0	Q1
INA226AIDGSRG4	VSSOP	DGS	10	2500	330.0	12.4	5.3	3.4	1.4	8.0	12.0	Q1
INA226AIDGST	VSSOP	DGS	10	250	330.0	12.4	5.25	3.35	1.25	8.0	12.0	Q1

TAPE AND REEL BOX DIMENSIONS



*All dimensions are nominal

Device	Package Type	Package Drawing	Pins	SPQ	Length (mm)	Width (mm)	Height (mm)
INA226AIDGSR	VSSOP	DGS	10	2500	353.0	353.0	32.0
INA226AIDGSR	VSSOP	DGS	10	2500	366.0	364.0	50.0
INA226AIDGSR	VSSOP	DGS	10	2500	366.0	364.0	50.0
INA226AIDGSRG4	VSSOP	DGS	10	2500	353.0	353.0	32.0
INA226AIDGST	VSSOP	DGS	10	250	366.0	364.0	50.0

DGS0010A



PACKAGE OUTLINE

VSSOP - 1.1 mm max height

SMALL OUTLINE PACKAGE



NOTES:

1. All linear dimensions are in millimeters. Any dimensions in parenthesis are for reference only. Dimensioning and tolerancing per ASME Y14.5M.
2. This drawing is subject to change without notice.
3. This dimension does not include mold flash, protrusions, or gate burrs. Mold flash, protrusions, or gate burrs shall not exceed 0.15 mm per side.
4. This dimension does not include interlead flash. Interlead flash shall not exceed 0.25 mm per side.
5. Reference JEDEC registration MO-187, variation BA.

EXAMPLE BOARD LAYOUT

DGS0010A

VSSOP - 1.1 mm max height

SMALL OUTLINE PACKAGE



LAND PATTERN EXAMPLE
SCALE:10X



SOLDER MASK DETAILS
NOT TO SCALE

4221984/A 05/2015

NOTES: (continued)

- 6. Publication IPC-7351 may have alternate designs.
- 7. Solder mask tolerances between and around signal pads can vary based on board fabrication site.

EXAMPLE STENCIL DESIGN

DGS0010A

VSSOP - 1.1 mm max height

SMALL OUTLINE PACKAGE



SOLDER PASTE EXAMPLE
BASED ON 0.125 mm THICK STENCIL
SCALE:10X

4221984/A 05/2015

NOTES: (continued)

8. Laser cutting apertures with trapezoidal walls and rounded corners may offer better paste release. IPC-7525 may have alternate design recommendations.
9. Board assembly site may have different recommendations for stencil design.

重要なお知らせと免責事項

TI は、技術データと信頼性データ (データシートを含みます)、設計リソース (リファレンス デザインを含みます)、アプリケーションや設計に関する各種アドバイス、Web ツール、安全性情報、その他のリソースを、欠陥が存在する可能性のある「現状のまま」提供しており、商品性および特定目的に対する適合性の黙示保証、第三者の知的財産権の非侵害保証を含むいかなる保証も、明示的または黙示的にかかわらず拒否します。

これらのリソースは、TI 製品を使用する設計の経験を積んだ開発者への提供を意図したものです。(1) お客様のアプリケーションに適した TI 製品の選定、(2) お客様のアプリケーションの設計、検証、試験、(3) お客様のアプリケーションに該当する各種規格や、その他のあらゆる安全性、セキュリティ、規制、または他の要件への確実な適合に関する責任を、お客様のみが単独で負うものとし、

上記の各種リソースは、予告なく変更される可能性があります。これらのリソースは、リソースで説明されている TI 製品を使用するアプリケーションの開発の目的でのみ、TI はその使用をお客様に許諾します。これらのリソースに関して、他の目的で複製することや掲載することは禁止されています。TI や第三者の知的財産権のライセンスが付与されている訳ではありません。お客様は、これらのリソースを自身で使用した結果発生するあらゆる申し立て、損害、費用、損失、責任について、TI およびその代理人を完全に補償するものとし、TI は一切の責任を拒否します。

TI の製品は、[TI の販売条件](#)、[TI の総合的な品質ガイドライン](#)、[ti.com](#) または TI 製品などに関連して提供される他の適用条件に従い提供されます。TI がこれらのリソースを提供することは、適用される TI の保証または他の保証の放棄の拡大や変更を意味するものではありません。TI がカスタム、またはカスタマー仕様として明示的に指定していない限り、TI の製品は標準的なカタログに掲載される汎用機器です。

お客様がいかなる追加条項または代替条項を提案する場合も、TI はそれらに異議を唱え、拒否します。

Copyright © 2026, Texas Instruments Incorporated

最終更新日 : 2025 年 10 月