

LM10-MIL オペアンプおよび基準電圧

1 特長

- 入力オフセット電圧: 2mV (最大値)
- 入力オフセット電流: 0.7nA (最大値)
- 入力バイアス電流: 20nA (最大値)
- 基準レギュレーション: 0.1% (最大値)
- オフセット電圧ドリフト係数: $2\mu\text{V}/^\circ\text{C}$
- 基準ドリフト係数: 0.002%/ $^\circ\text{C}$

2 アプリケーション

- リモート・アンプ
- バッテリ残量インジケータ
- 熱電対トランスミッタ
- 電圧および電流レギュレータ

3 概要

LM10-MILはモノリシックなリアICで、高精度の基準電圧、可変の基準バッファ、独立した高品質のオペアンプで構成されます。

このユニットは最低1.1V、最高40Vの合計電源電圧で動作でき、消費電流はわずか $270\mu\text{A}$ です。補完出力段は電源端子の15mV以内にシングするか、または $\pm 0.4\text{V}$ の飽和で $\pm 20\text{mA}$ の出力電流を供給します。基準電圧出力は最低200mVに設定できます。

この回路は携帯用機器向けに推奨され、単一の電源セルからの動作が完全に規定されています。一方で、電圧と電流の両方での高い出力駆動能力と、熱過負荷からの保護を備えているため、要求の厳しい汎用アプリケーションにも適しています。

このデバイスは、固定電源に依存しないフローティング・モードで動作できます。リモート・コンパレータ、信号コンディショナ、SCRコントローラまたはアナログ信号トランスミッタとして機能し、処理した信号を電源と同じラインで送出できます。このデバイスは、広範な電圧および電流レギュレータ・アプリケーションでの使用にも適しており、低電圧から数百ボルトまでに対応でき、既存のICよりも高い精度が得られます。

このシリーズは3つの標準温度範囲で利用可能で、商用部品では制限が緩和されています。さらに、低電圧仕様(接尾辞L)が用意されており、温度範囲が制限される代わりにコストを低減できます。

製品情報⁽¹⁾

型番	パッケージ	本体サイズ(公称)
LM10-MIL	SOIC (14)	8.992mm×7.498mm
	SDIP (8)	8.255mm×8.255mm
	PDIP (8)	9.81mm×6.35mm

(1) 提供されているすべてのパッケージについては、巻末の注文情報を参照してください。

オペアンプ回路図

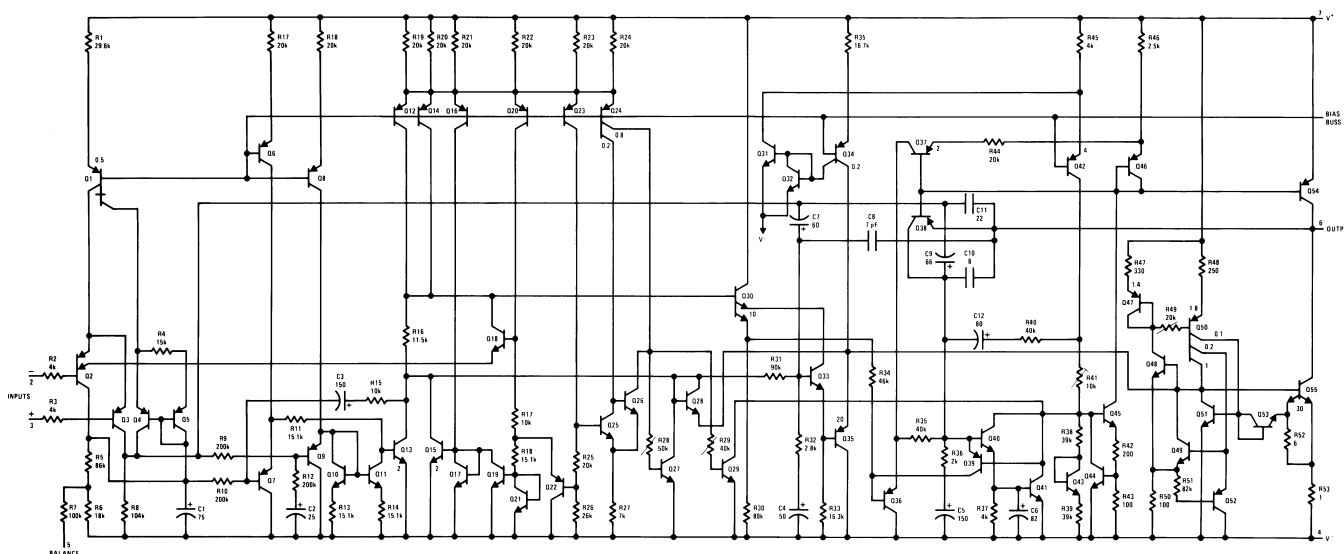

(ピン番号は8ピン・パッケージのもので)



目次

1	特長	1	8	Application and Implementation	14
2	アプリケーション	1	8.1	Application Information.....	14
3	概要	1	8.2	Typical Application	14
4	改訂履歴	2	8.3	System Examples	15
5	Pin Configuration and Functions	3	9	Power Supply Recommendations	23
6	Specifications	4	10	Layout	23
6.1	Absolute Maximum Ratings	4	10.1	Layout Guidelines	23
6.2	Recommended Operating Conditions	4	10.2	Layout Example	23
6.3	Thermal Information	4	11	デバイスおよびドキュメントのサポート	24
6.4	Electrical Characteristics.....	5	11.1	デバイス・サポート	24
6.5	Typical Characteristics	7	11.2	ドキュメントのサポート.....	24
7	Detailed Description	13	11.3	コミュニティ・リソース	24
7.1	Overview	13	11.4	商標	24
7.2	Functional Block Diagram	13	11.5	静電気放電に関する注意事項	25
7.3	Feature Description.....	13	11.6	Glossary	25
7.4	Device Functional Modes.....	13	12	メカニカル、パッケージ、および注文情報	25

4 改訂履歴

日付	改訂内容	注
2017年6月	*	初版

5 Pin Configuration and Functions

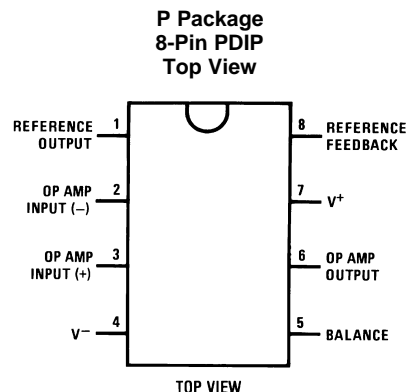
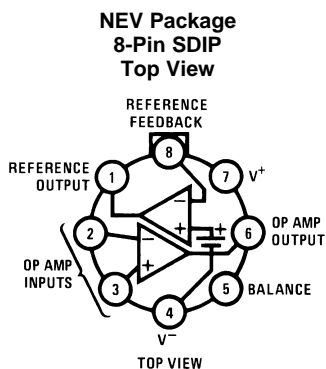

Pin Functions — 8-Pin SDIP or PDIP

PIN		I/O	DESCRIPTION
NAME	NO.		
Balance	5	I	Used for offset nulling
Op Amp Input (+)	3	I	Noninverting input of operational amplifier
Op Amp Input (-)	2	I	Inverting input of operational amplifier
Op Amp Output	6	O	Output terminal of operational amplifier
Reference Feedback	8	I	Feedback terminal of reference
Reference Output	1	O	Output terminal of reference
V+	7	I	Positive supply voltage
V-	4	I	Negative supply voltage

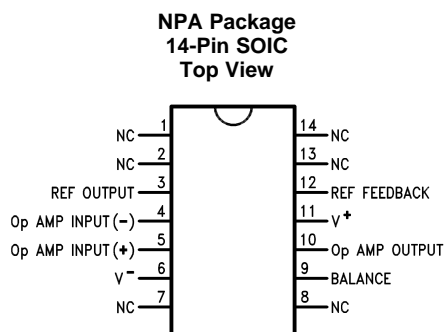

Pin Functions — 14-Pin SOIC

PIN		I/O	DESCRIPTION
NAME	NO.		
Balance	9	I	Used for offset nulling
NC	1, 2, 7, 8, 14, 13	—	No connection
Op Amp Input (-)	4	I	Inverting input of operational amplifier
Op Amp Input (+)	5	I	Noninverting input of operational amplifier
Op Amp Output	10	O	Output terminal of operational amplifier
Reference Feedback	12	I	Feedback terminal of reference
Reference Output	3	O	Output terminal of reference
V+	11	I	Positive supply voltage
V-	6	I	Negative supply voltage

6 Specifications

6.1 Absolute Maximum Ratings

 See ⁽¹⁾⁽²⁾⁽³⁾

		MIN	MAX	UNIT
Total supply voltage			45	V
Differential input voltage ⁽⁴⁾			±40	V
Power dissipation ⁽⁵⁾		Internally limited		
Output short-circuit duration ⁽⁶⁾		Continuous		
Lead temperature	TO	Soldering (10 seconds)		300 °C
	DIP	Soldering (10 seconds)		260 °C
		Vapor phase (60 seconds)		215 °C
		Infrared (15 seconds)		220 °C
Maximum junction temperature			150	°C
Storage temperature, T _{stg}		-55	150	°C

- (1) Refer to RETS10X for LM10H military specifications.
- (2) Stresses beyond those listed under *Absolute Maximum Ratings* may cause permanent damage to the device. These are stress ratings only, and functional operation of the device at these or any other conditions beyond those indicated under *Recommended Operating Conditions* is not implied. Exposure to absolute-maximum-rated conditions for extended periods may affect device reliability.
- (3) If Military/Aerospace specified devices are required, please contact the TI Sales Office/Distributors for availability and specifications.
- (4) The Input voltage can exceed the supply voltages provided that the voltage from the input to any other terminal does not exceed the maximum differential input voltage and excess dissipation is accounted for when $V_{IN} < V^-$.
- (5) The maximum, operating-junction temperature is 150°C for the LM10-MIL. At elevated temperatures, devices must be derated based on package thermal resistance.
- (6) Internal thermal limiting prevents excessive heating that could result in sudden failure, but the IC can be subjected to accelerated stress with a shorted output and worst-case conditions.

6.2 Recommended Operating Conditions

over operating free-air temperature range (unless otherwise noted)

		MIN	NOM	MAX	UNIT
V _S	Supply input voltage range (V ⁻) – (V ⁺)	1.2		40	V
V _{CM}	Common-mode voltage	(V ⁻)		(V ⁺) – 0.85	V
V _{REF}	Reference voltage		0.2		V
I _{REF}	Reference current	0		1	mA

6.3 Thermal Information

THERMAL METRIC ⁽¹⁾		LM10-MIL			UNIT
		NEV (SDIP)	NPA (SOIC)	P (PDIP)	
		8 PINS	14 PINS	8 PINS	
R _{θJA}	Junction-to-ambient thermal resistance	150	90	87	°C/W
R _{θJC(top)}	Junction-to-case (top) thermal resistance	45	—	—	°C/W

- (1) For more information about traditional and new thermal metrics, see the *Semiconductor and IC Package Thermal Metrics* application report, [SPRA953](#).

6.4 Electrical Characteristics

 $T_J = 25^\circ\text{C}$ unless otherwise specified⁽¹⁾

PARAMETER	TEST CONDITIONS	MIN	TYP	MAX	UNIT
Input offset voltage	$T_J = 25^\circ\text{C}$		0.3	2	mV
	$T_{\text{MIN}} \leq T_J \leq T_{\text{MAX}}$ (see ⁽¹⁾)			3	mV
Input offset current ⁽²⁾	$T_J = 25^\circ\text{C}$		0.25	0.7	nA
	$T_{\text{MIN}} \leq T_J \leq T_{\text{MAX}}$ (see ⁽¹⁾)			1.5	nA
Input bias current	$T_J = 25^\circ\text{C}$		10	20	nA
	$T_{\text{MIN}} \leq T_J \leq T_{\text{MAX}}$ (see ⁽¹⁾)			30	nA
Input resistance	$T_J = 25^\circ\text{C}$	250	500		k Ω
	$T_{\text{MIN}} \leq T_J \leq T_{\text{MAX}}$ (see ⁽¹⁾)	150			k Ω
Large signal voltage gain	$V_S = \pm 20\text{ V}$, $I_{\text{OUT}} = 0$	120	400		V/mV
	$V_{\text{OUT}} = \pm 19.95\text{ V}$, $T_{\text{MIN}} \leq T_J \leq T_{\text{MAX}}$ (see ⁽¹⁾)	80			V/mV
	$V_S = \pm 20\text{ V}$, $V_{\text{OUT}} = \pm 19.4\text{ V}$	50	130		V/mV
	$I_{\text{OUT}} = \pm 20\text{ mA}$, $T_{\text{MIN}} \leq T_J \leq T_{\text{MAX}}$ (see ⁽¹⁾)	20			V/mV
	$I_{\text{OUT}} = \pm 15\text{ mA}$, $T_{\text{MIN}} \leq T_J \leq T_{\text{MAX}}$ (see ⁽¹⁾)	20			V/mV
	$V_S = \pm 0.6\text{ V}$, $I_{\text{OUT}} = \pm 2\text{ mA}$	1.5	3		V/mV
	$V_S = \pm 0.65\text{ V}$, $I_{\text{OUT}} = \pm 2\text{ mA}$, $T_{\text{MIN}} \leq T_J \leq T_{\text{MAX}}$ (see ⁽¹⁾)	1.5	3		V/mV
	$V_{\text{OUT}} = \pm 0.4\text{ V}$, $T_{\text{MIN}} \leq T_J \leq T_{\text{MAX}}$ (see ⁽¹⁾)	0.5			V/mV
Shunt gain ⁽³⁾	$V_{\text{OUT}} = \pm 0.3\text{ V}$, $V_{\text{CM}} = -0.4\text{ V}$, $T_{\text{MIN}} \leq T_J \leq T_{\text{MAX}}$ (see ⁽¹⁾)	0.5			V/mV
	$1.2\text{ V} \leq V_{\text{OUT}} \leq 40\text{ V}$, $R_L = 1.1\text{ k}\Omega$	14	33		V/mV
	$1.3\text{ V} \leq V_{\text{OUT}} \leq 40\text{ V}$, $R_L = 1.1\text{ k}\Omega$, $T_{\text{MIN}} \leq T_J \leq T_{\text{MAX}}$ (see ⁽¹⁾)	14	33		V/mV
	$0.1\text{ mA} \leq I_{\text{OUT}} \leq 5\text{ mA}$, $T_{\text{MIN}} \leq T_J \leq T_{\text{MAX}}$ (see ⁽¹⁾)	6			V/mV
	$1.5\text{ V} \leq V^+ \leq 40\text{ V}$, $R_L = 250\ \Omega$	8	25		V/mV
Common-mode rejection	$0.1\text{ mA} \leq I_{\text{OUT}} \leq 20\text{ mA}$, $T_{\text{MIN}} \leq T_J \leq T_{\text{MAX}}$ (see ⁽¹⁾)	4			V/mV
	$-20\text{ V} \leq V_{\text{CM}} \leq 19.15\text{ V}$	93	102		dB
	$-20\text{ V} \leq V_{\text{CM}} \leq 19\text{ V}$, $T_{\text{MIN}} \leq T_J \leq T_{\text{MAX}}$ (see ⁽¹⁾)	93	102		dB
Supply-voltage rejection	$V_S = \pm 20\text{ V}$, $T_{\text{MIN}} \leq T_J \leq T_{\text{MAX}}$ (see ⁽¹⁾)	87			dB
	$-0.2\text{ V} \geq V^- \geq -39\text{ V}$	90	96		dB
	$V^+ = 1\text{ V}$, $T_{\text{MIN}} \leq T_J \leq T_{\text{MAX}}$ (see ⁽¹⁾)	84			dB
	$V^+ = 1.1\text{ V}$, $T_{\text{MIN}} \leq T_J \leq T_{\text{MAX}}$ (see ⁽¹⁾)	84			dB
	$1\text{ V} \leq V^+ \leq 39.8\text{ V}$	96	106		dB
	$1.1\text{ V} \leq V^+ \leq 39.8\text{ V}$, $T_{\text{MIN}} \leq T_J \leq T_{\text{MAX}}$ (see ⁽¹⁾)	96	106		dB
Offset voltage drift	$V^- = -0.2\text{ V}$, $T_{\text{MIN}} \leq T_J \leq T_{\text{MAX}}$ (see ⁽¹⁾)	90			dB
			2		$\mu\text{V}/^\circ\text{C}$
Offset current drift			2		$\text{pA}/^\circ\text{C}$
Bias current drift	$T_C < 100^\circ\text{C}$		60		$\text{pA}/^\circ\text{C}$
Line regulation	$1.2\text{ V} \leq V_S \leq 40\text{ V}$		0.001	0.003	%/V
	$1.3\text{ V} \leq V_S \leq 40\text{ V}$, $T_{\text{MIN}} \leq T_J \leq T_{\text{MAX}}$ (see ⁽¹⁾)		0.001	0.003	%/V
	$0 \leq I_{\text{REF}} \leq 1\text{ mA}$, $V_{\text{REF}} = 200\text{ mV}$, $T_{\text{MIN}} \leq T_J \leq T_{\text{MAX}}$ (see ⁽¹⁾)			0.006	%/V
Load regulation	$0 \leq I_{\text{REF}} \leq 1\text{ mA}$		0.01%	0.1%	
	$V^+ - V_{\text{REF}} \geq 1\text{ V}$, $T_{\text{MIN}} \leq T_J \leq T_{\text{MAX}}$ (see ⁽¹⁾)			0.15%	
	$V^+ - V_{\text{REF}} \geq 1.1\text{ V}$, $T_{\text{MIN}} \leq T_J \leq T_{\text{MAX}}$ (see ⁽¹⁾)			0.15%	

(1) These specifications apply for $V^- \leq V_{\text{CM}} \leq V^+ - 0.85\text{ V}$, 1 V ($T_{\text{MIN}} \leq T_J \leq T_{\text{MAX}}$), 1.2 V , 1.3 V ($T_{\text{MIN}} \leq T_J \leq T_{\text{MAX}}$) $< V_S \leq V_{\text{MAX}}$, $V_{\text{REF}} = 0.2\text{ V}$ and $0 \leq I_{\text{REF}} \leq 1\text{ mA}$, unless otherwise specified: $V_{\text{MAX}} = 40\text{ V}$ for the standard part and 6.5 V for the low voltage part. The full-temperature-range operation is -55°C to 125°C for the LM10-MIL. The specifications do not include the effects of thermal gradients ($\tau_1 \approx 20\text{ ms}$), die heating ($\tau_2 \approx 0.2\text{ s}$) or package heating. Gradient effects are small and tend to offset the electrical error (see curves).

(2) For $T_J > 90^\circ\text{C}$, I_{OS} may exceed 1.5 nA for $V_{\text{CM}} = V^-$. With $T_J = 125^\circ\text{C}$ and $V^- \leq V_{\text{CM}} \leq V^- + 0.1\text{ V}$, $I_{\text{OS}} \leq 5\text{ nA}$.

(3) This defines operation in floating applications such as the bootstrapped regulator or two-wire transmitter. Output is connected to the V^+ terminal of the IC and input common mode is referred to V^- (see [System Examples](#)). Effect of larger output-voltage swings with higher load resistance can be accounted for by adding the positive-supply rejection error.

Electrical Characteristics (continued)
 $T_J = 25^\circ\text{C}$ unless otherwise specified⁽¹⁾

PARAMETER	TEST CONDITIONS		MIN	TYP	MAX	UNIT
Amplifier gain	$0.2\text{ V} \leq V_{\text{REF}} \leq 35\text{ V}$	$T_J = 25^\circ\text{C}$	50	75		V/mV
		$T_{\text{MIN}} \leq T_J \leq T_{\text{MAX}}$ (see ⁽¹⁾)	23			V/mV
Feedback sense voltage	$T_J = 25^\circ\text{C}$		195	200	205	mV
	$T_{\text{MIN}} \leq T_J \leq T_{\text{MAX}}$ (see ⁽¹⁾)		194		206	mV
Feedback current	$T_J = 25^\circ\text{C}$			20	50	nA
	$T_{\text{MIN}} \leq T_J \leq T_{\text{MAX}}$ (see ⁽¹⁾)				65	nA
Reference drift				0.002		%/ $^\circ\text{C}$
Supply current	$T_J = 25^\circ\text{C}$			270	400	μA
	$T_{\text{MIN}} \leq T_J \leq T_{\text{MAX}}$ (see ⁽¹⁾)				500	μA
Supply current change	$1.2\text{ V} \leq V_S \leq 40\text{ V}$	$T_J = 25^\circ\text{C}$		15		μA
		$T_{\text{MIN}} \leq T_J \leq T_{\text{MAX}}$ (see ⁽¹⁾)			75	μA
	$1.3\text{ V} \leq V_S \leq 40\text{ V}$	$T_J = 25^\circ\text{C}$		15		μA
		$T_{\text{MIN}} \leq T_J \leq T_{\text{MAX}}$ (see ⁽¹⁾)			75	μA

6.5 Typical Characteristics

6.5.1 Typical Characteristics (Op Amp)

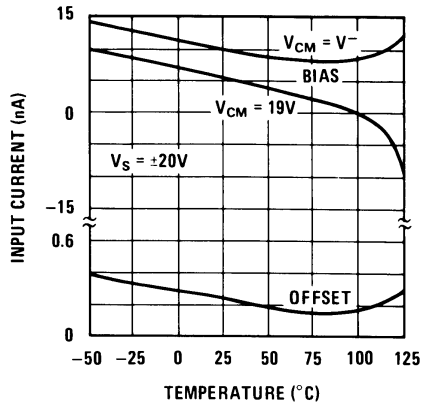

Figure 1. Input Current

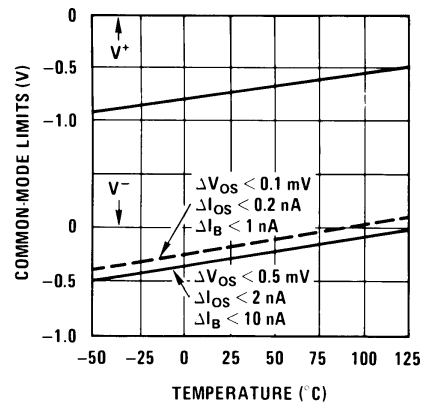

Figure 2. Common-Mode Limits

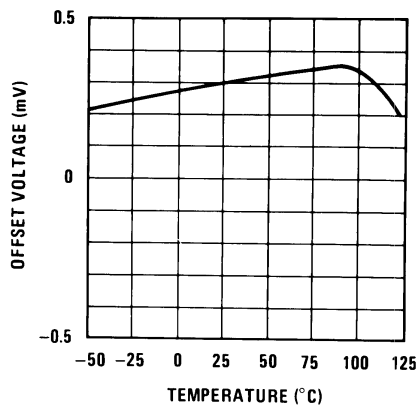

Figure 3. Output Voltage Drift

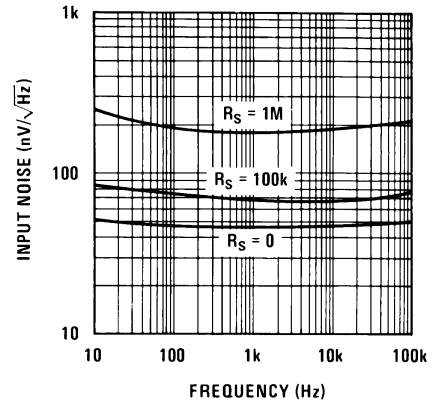

Figure 4. Input Noise Voltage

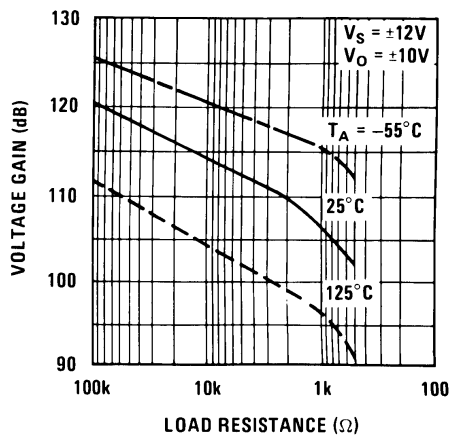

Figure 5. DC Voltage Gain

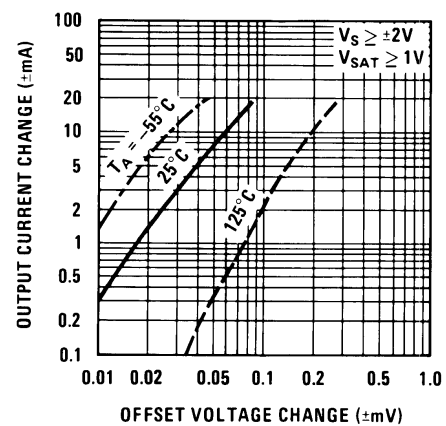

Figure 6. Transconductance

Typical Characteristics (Op Amp) (continued)

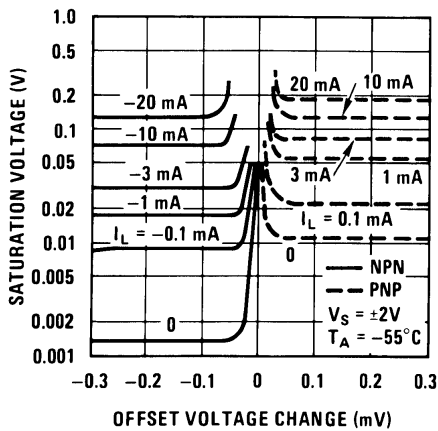

Figure 7. Output Saturation Characteristics

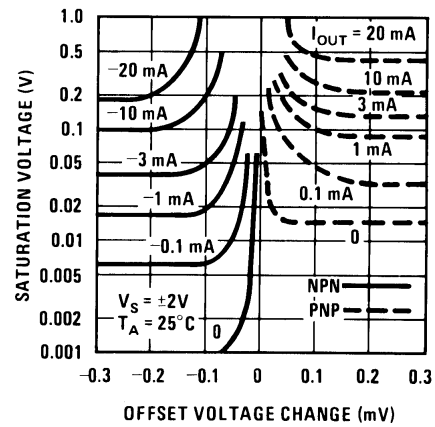

Figure 8. Output Saturation Characteristics

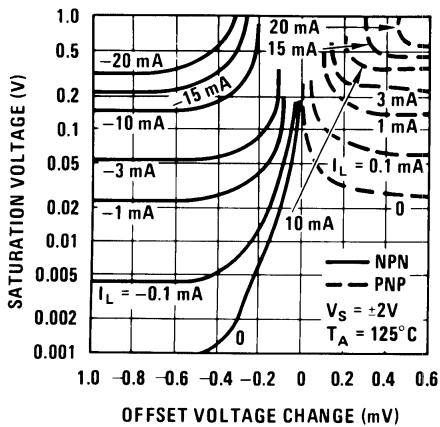

Figure 9. Output Saturation Characteristics

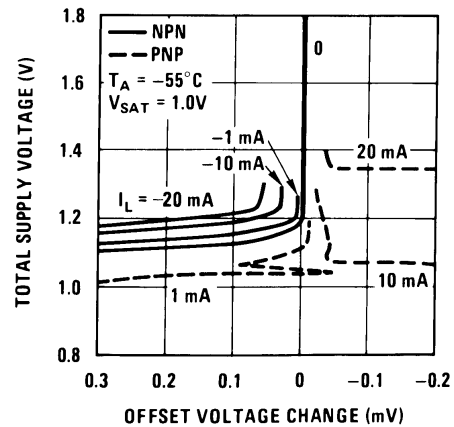

Figure 10. Minimum Supply Voltage

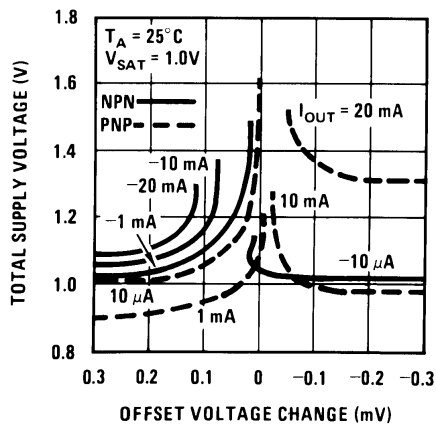

Figure 11. Minimum Supply Voltage

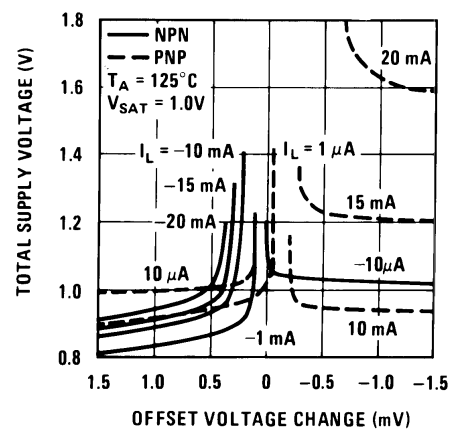

Figure 12. Minimum Supply Voltage

Typical Characteristics (Op Amp) (continued)

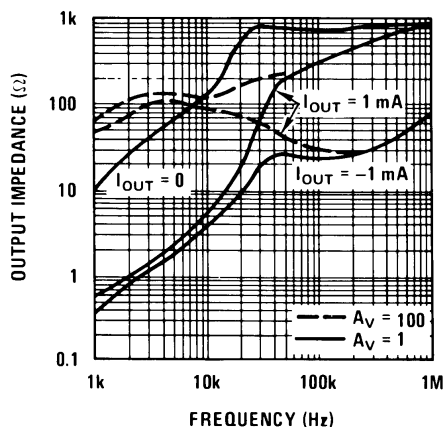

Figure 13. Output Impedance

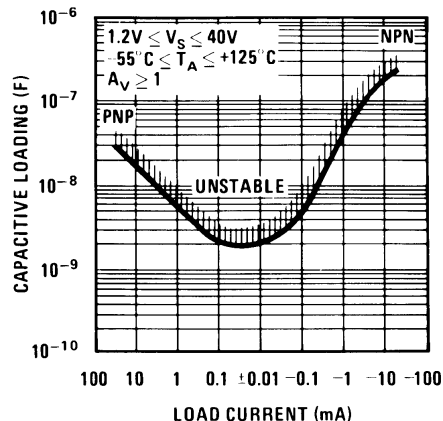

Figure 14. Typical Stability Range

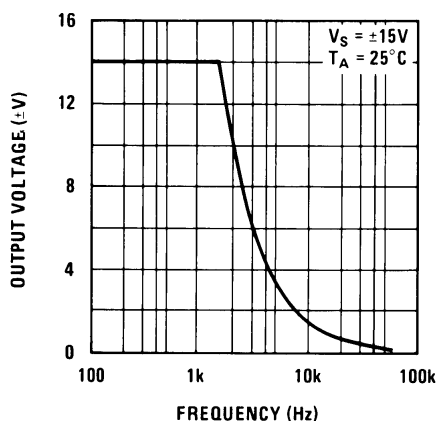

Figure 15. Large Signal Response

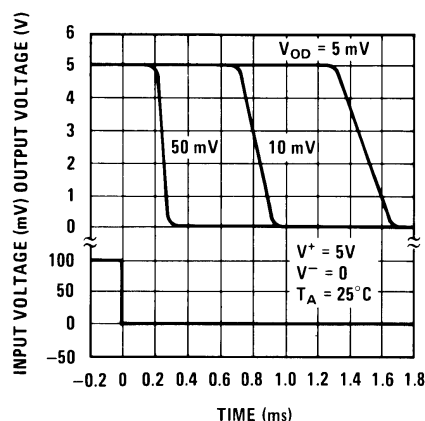

Figure 16. Comparator Response Time For Various Input Overdrives

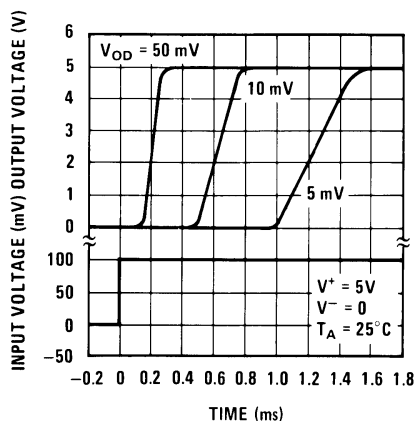

Figure 17. Comparator Response Time For Various Input Overdrives

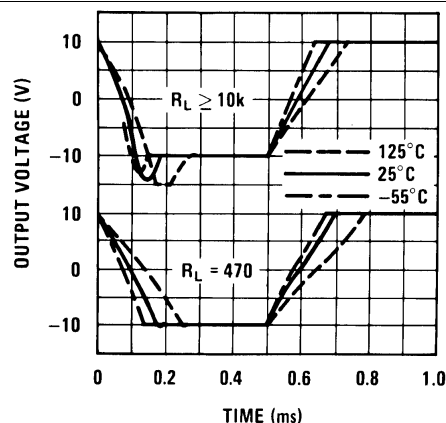

Figure 18. Follower Pulse Response

Typical Characteristics (Op Amp) (continued)

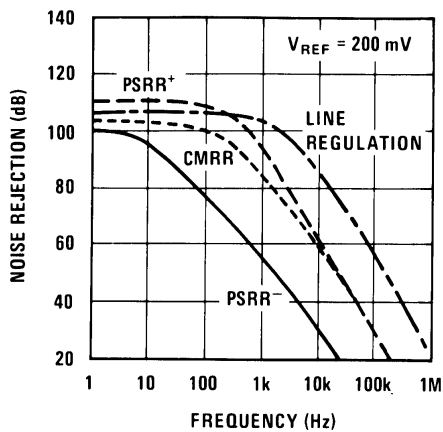

Figure 19. Noise Rejection

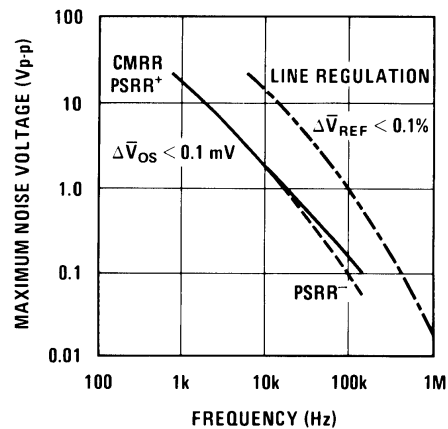

Figure 20. Rejection Slew Limiting

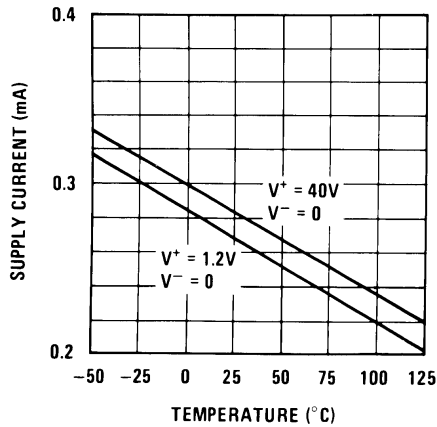

Figure 21. Supply Current

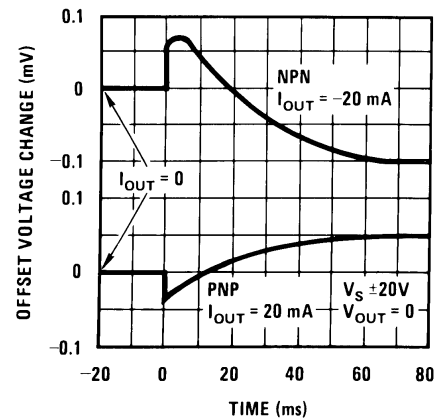

Figure 22. Thermal Gradient Feedback

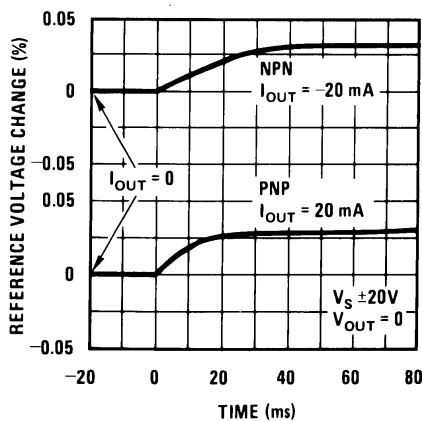

Figure 23. Thermal Gradient Cross-Coupling

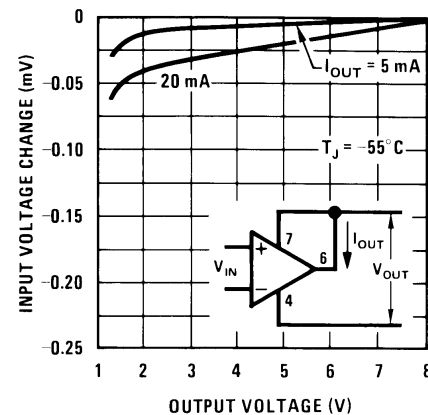

Figure 24. Shunt Gain

Typical Characteristics (Op Amp) (continued)

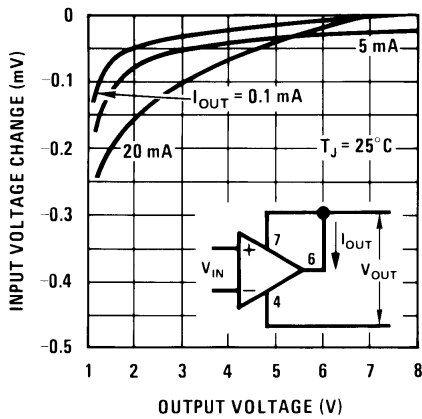

Figure 25. Shunt Gain

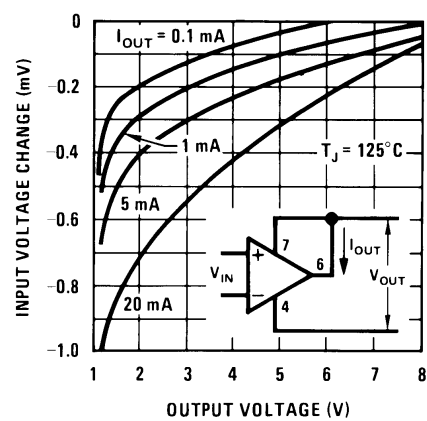

Figure 26. Shunt Gain

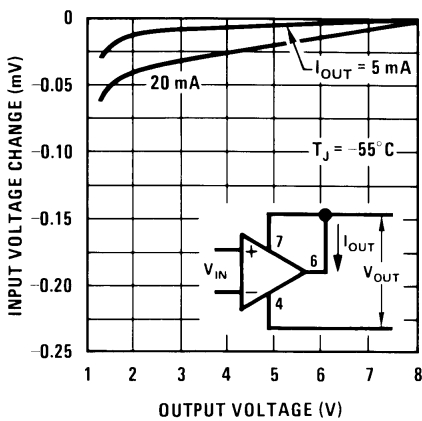

Figure 27. Shunt Gain

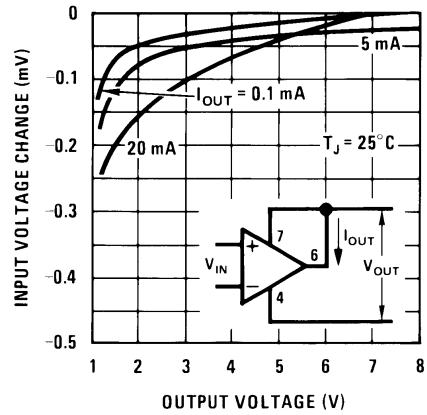

Figure 28. Shunt Gain

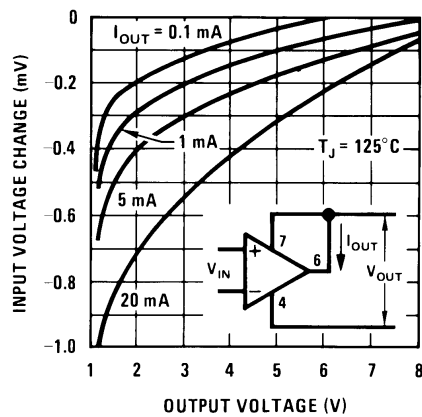

Figure 29. Shunt Gain

6.5.2 Typical Characteristics (Reference)

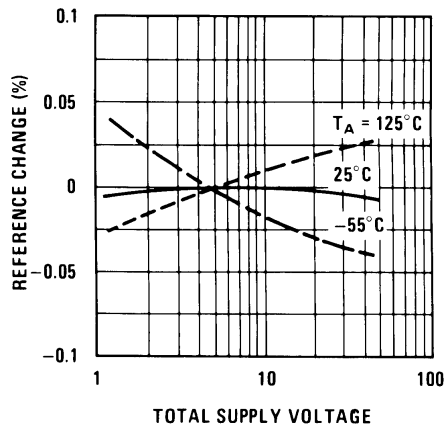

Figure 30. Line Regulation

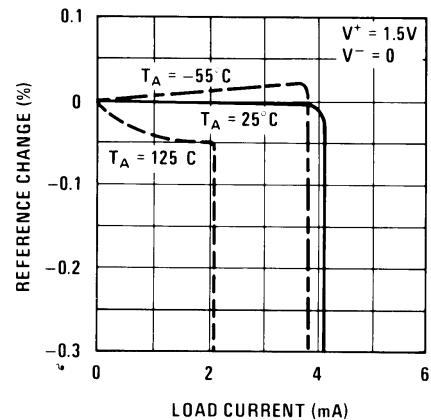

Figure 31. Load Regulation

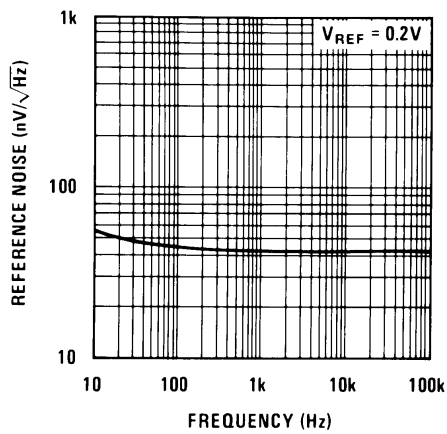

Figure 32. Reference Noise Voltage

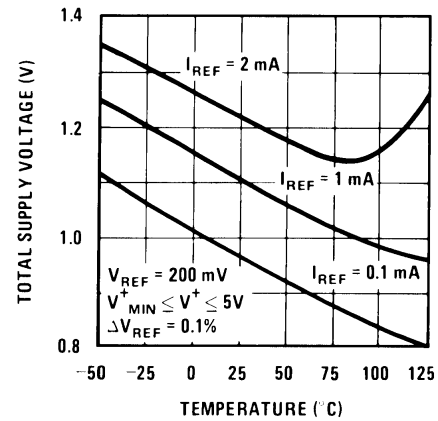

Figure 33. Minimum Supply Voltage

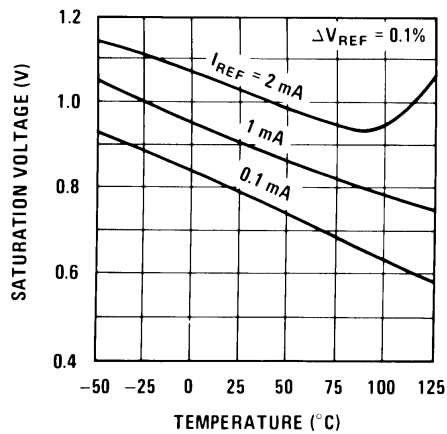

Figure 34. Output Saturation

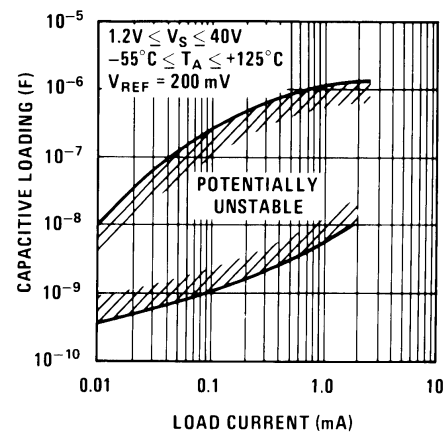

Figure 35. Typical Stability Range

7 Detailed Description

7.1 Overview

The LM10-MIL is a dual-operational amplifier combined with a voltage reference capable of a single-supply operation down to 1.1 V. It provides high overall performance, making it ideal for many general-purpose applications. The circuit can also operate in a floating mode, powered by residual voltage, independent of fixed supplies and it is well-protected from temperature drift.

7.2 Functional Block Diagram

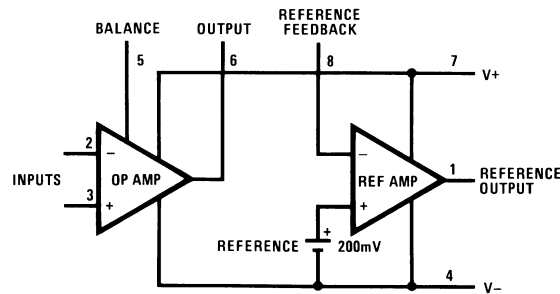

7.3 Feature Description

7.3.1 Operating Characteristics

The LM10-MIL is specified for operation from 1.2 V to 40 V. Many of the specifications apply from -55°C to 125°C . Parameters that can exhibit significant variance with regard to operating voltage or temperature are presented in electrical characteristics tables under [Specifications](#) and in the [Typical Characteristics](#) section.

7.3.2 Common-Mode Voltage Range

The input common-mode voltage range of the LM10-MIL extends from the negative rail to 0.85 V less than the positive rail.

7.3.3 Operational Amplifier

The minimum operating voltage is reduced to nearly one volt and the current gain is less affected by temperature, resulting in a fairly flat bias current over temperature.

7.3.4 Voltage Reference

Second-order nonlinearities are compensated for which eliminates the bowed characteristics of conventional designs, resulting in better temperature stability.

7.4 Device Functional Modes

7.4.1 Floating Mode

To use the device in a floating mode, the operational amplifier output is shorted to $V+$ which disables the PNP portion of the output stage. Thus, with a positive input signal, neither halves of the output conducts and the current between the supply terminals is equal to the quiescent supply current. With negative input signals, the NPN portion of the output begins to turn on, reaching the short circuit current for a few hundred microvolts overdrive.

7.4.2 Linear Operation

This device can also operate linearly while in the floating mode. An example of this is shown in the [Typical Application](#) section.

8 Application and Implementation

NOTE

Information in the following applications sections is not part of the TI component specification, and TI does not warrant its accuracy or completeness. TI's customers are responsible for determining suitability of components for their purposes. Customers should validate and test their design implementation to confirm system functionality.

8.1 Application Information

With heavy amplifier loading to V^- , resistance drops in the V^- lead can adversely affect reference regulation. Lead resistance can approach $1\ \Omega$. Therefore, the common to the reference circuitry should be connected as close as possible to the package.

8.2 Typical Application

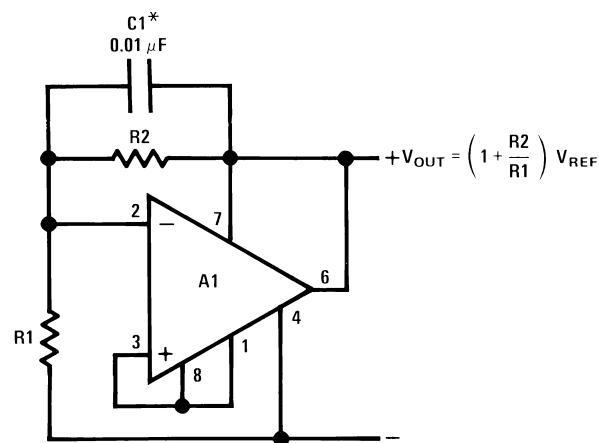

* required for capacitive loading

Figure 36. Shunt Voltage Regulator

8.2.1 Design Requirements

Table 1 lists the design parameters for this example.

Table 1. Design Parameters

DESIGN PARAMETERS	EXAMPLE VALUE
Ambient Temperature Range	–55°C to 125°C
Supply Voltage Range	1.2 V to 40 V
Common-Mode Input Range	(V^-) to (V^+) – 0.85 V

8.2.2 Detailed Design Procedure

Given that the transfer function of this circuit is:

$$V_{OUT} = \left(1 + \frac{R_2}{R_1}\right) V_{REF} \quad (1)$$

the output can be set between 0.2 V and the breakdown voltage of the IC by selecting an appropriate value for R_2 . The circuit regulates for input voltages within a saturation drop of the output (typically 0.4 V at 20 mA and 0.15 V at 5 mA). The regulator is protected from shorts or overloads by current limiting and thermal shutdown.

Typical regulation is about 0.05% load and 0.003%/V line. A substantial improvement in regulation can be effected by connecting the operational amplifier as a follower and setting the reference to the desired output voltage. This has the disadvantage that the minimum input-output differential is increased to a little more than a diode drop. If the operational amplifier were connected for a gain of 2, the output could again saturate. But this requires an additional pair of precision resistors.

The regulator in Figure 36 could be made adjustable to zero by connecting the operational amplifier to a potentiometer on the reference output. This has the disadvantage that the regulation at the lower voltage settings is not as good as it might otherwise be.

8.2.3 Application Curve

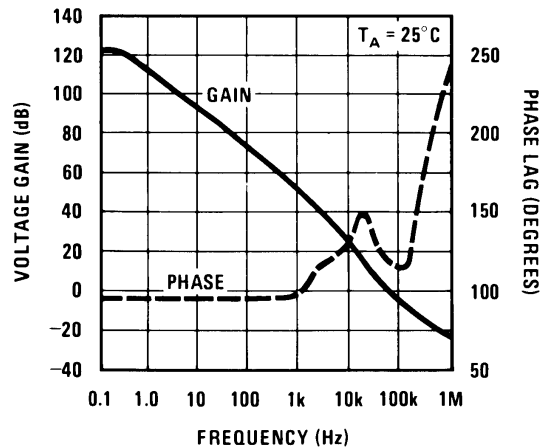

Figure 37. Frequency Response

8.3 System Examples

Circuit descriptions available in application note AN-211 ([SNOA638](#)).

8.3.1 Operational Amplifier Offset Adjustment

(Pin numbers are for 8-pin packages)

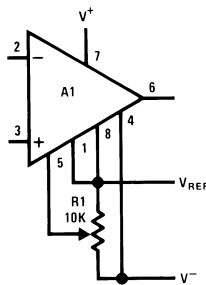

Figure 38. Standard

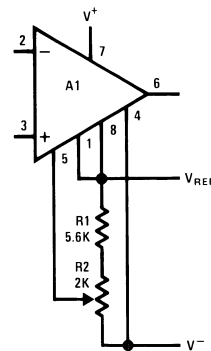

Figure 39. Limited Range

System Examples (continued)

(Pin numbers are for 8-pin packages)

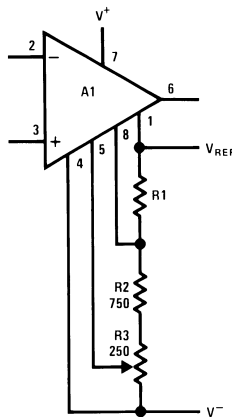

Figure 40. Limited Range With Boosted Reference

8.3.2 Positive Regulators

(Pin numbers are for 8-pin packages)

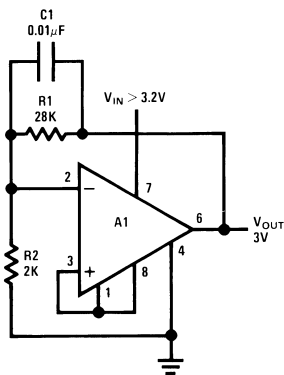

Figure 41. Low Voltage

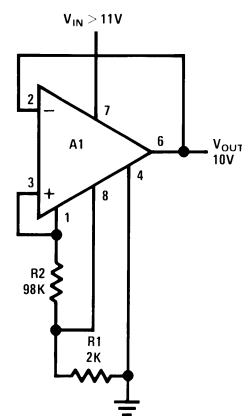
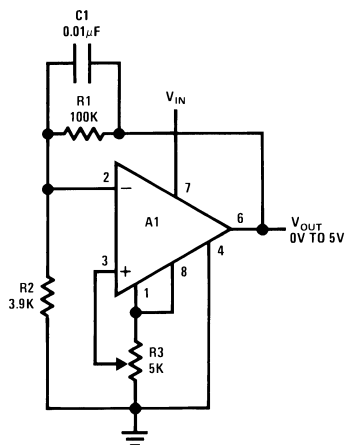

Figure 42. Best Regulation



Use only electrolytic output capacitors.

Figure 43. Zero Output

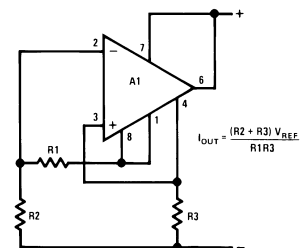
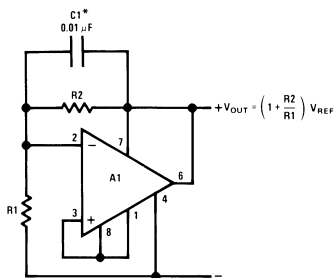

Figure 44. Current Regulator

System Examples (continued)

(Pin numbers are for 8-pin packages)



Required For Capacitive Loading

Figure 45. Shunt Regulator

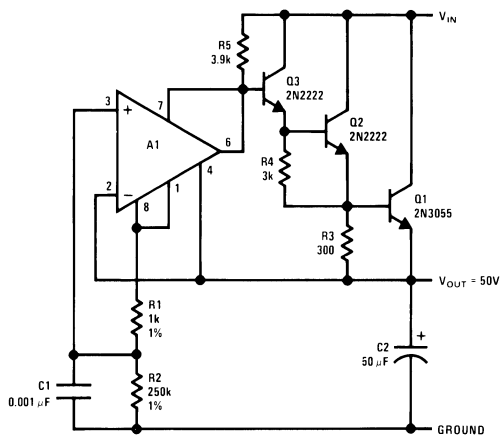
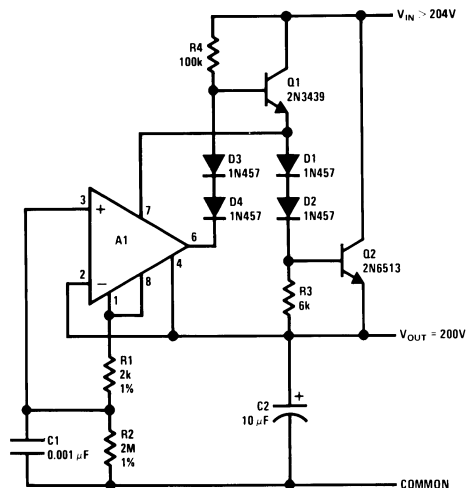
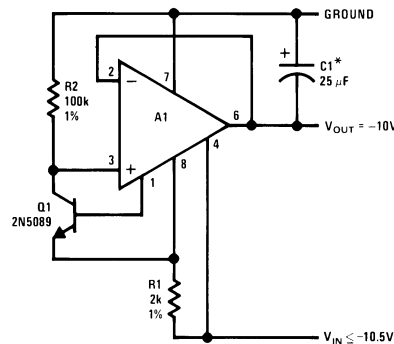

Figure 47. Precision Regulator



$$V_{OUT} = \frac{R_2}{R_1} V_{REF}$$

Figure 49. HV Regulator



*Electrolytic

Figure 46. Negative Regulator

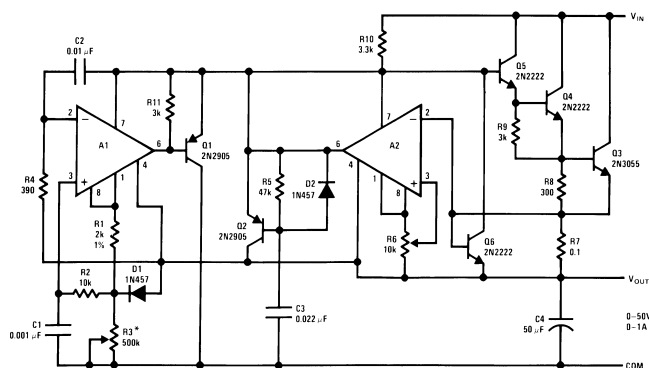

$$*V_{OUT} = 10^{-4} R_3$$

Figure 48. Laboratory Power Supply

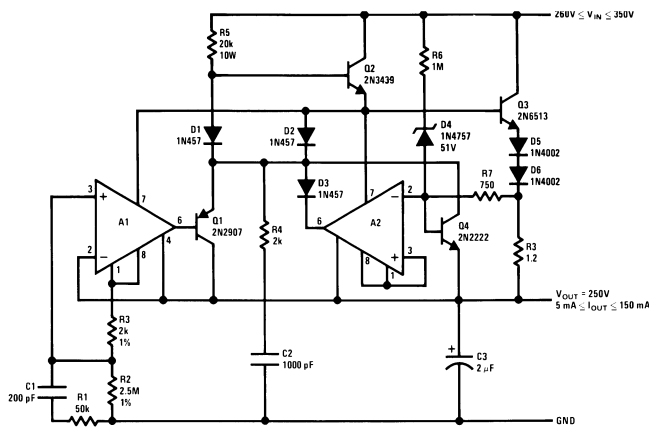
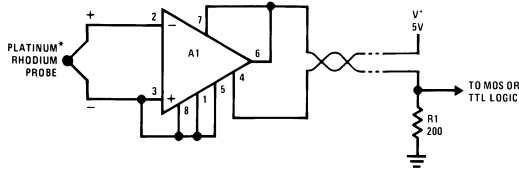

Figure 50. Protected HV Regulator

System Examples (continued)

(Pin numbers are for 8-pin packages)



*800°C Threshold Is Established By Connecting Balance To V_{REF}.

Figure 51. Flame Detector

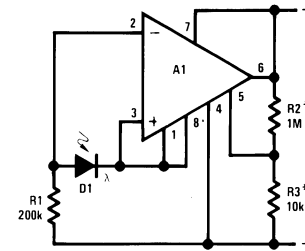

*Provides Hysteresis

Figure 52. Light Level Sensor

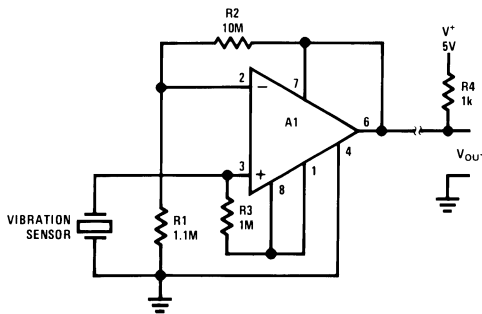

Figure 53. Remote Amplifier

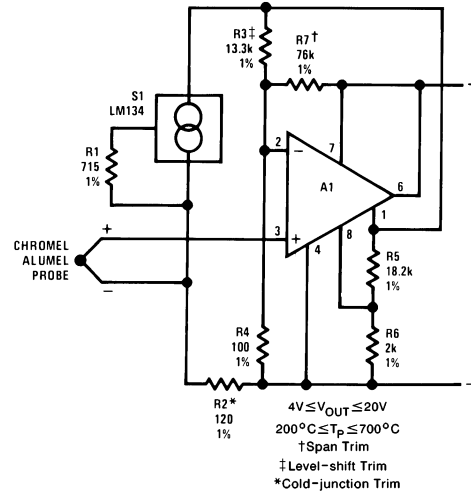

Figure 54. Remote Thermocouple Amplifier

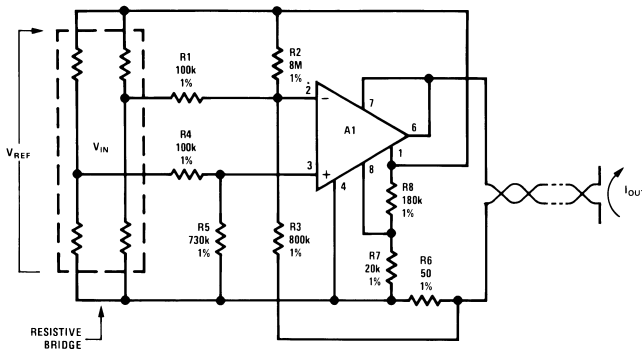
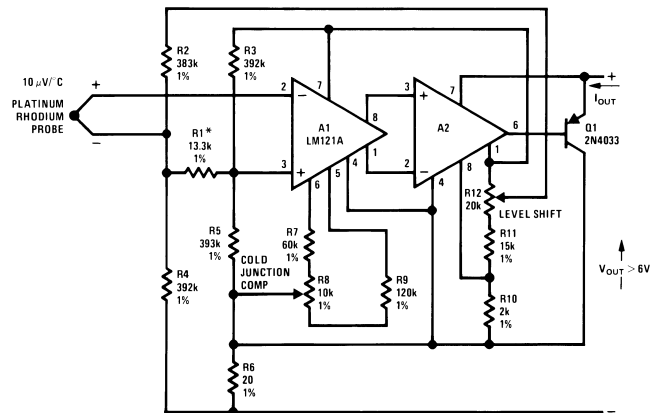

Figure 55. Transmitter for Bridge Sensor



$10 \mu V/^\circ C$
 $10 \text{ mA} \leq I_{OUT} \leq 50 \text{ mA}$
 $500^\circ C \leq T_P \leq 1500^\circ C$
 *Gain Trim

Figure 56. Precision Thermocouple Transmitter

System Examples (continued)

(Pin numbers are for 8-pin packages)

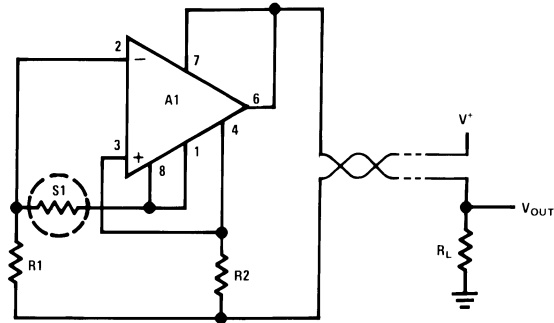
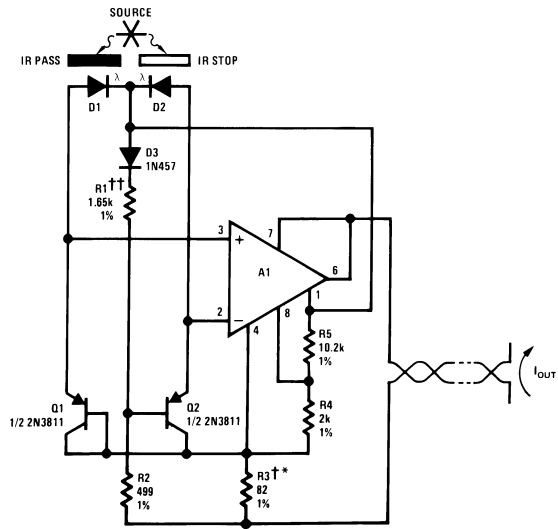
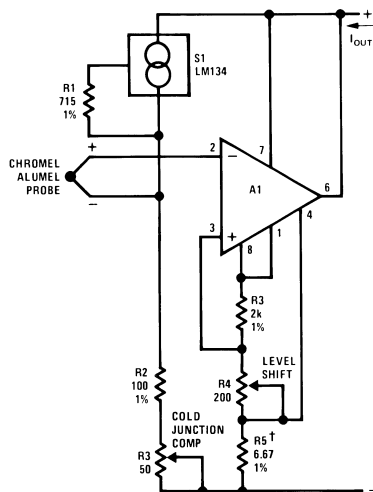

Figure 57. Resistance Thermometer Transmitter



††Level-shift Trim
 *Scale Factor Trim
 †Copper Wire Wound
 $1 \text{ mA} \leq I_{OUT} \leq 5 \text{ mA}$
 $0.01 \leq \frac{I_{D2}}{I_{D1}} \leq 100$

Figure 58. Optical Pyrometer



$200^{\circ}\text{C} \leq T_p \leq 700^{\circ}\text{C}$
 $1 \text{ mA} \leq I_{OUT} \leq 5 \text{ mA}$
 †Gain Trim

Figure 59. Thermocouple Transmitter

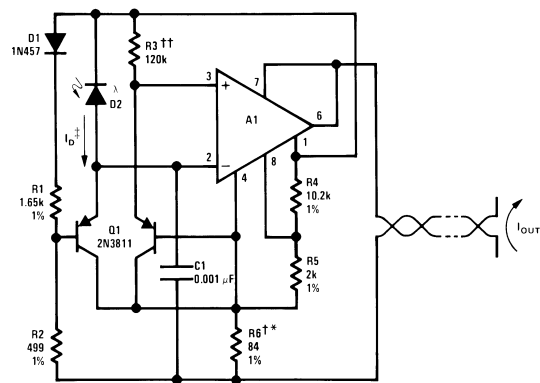

$1 \text{ mA} \leq I_{OUT} \leq 5 \text{ mA}$
 $\pm 50 \mu\text{A} \leq I_D \leq 500 \mu\text{A}$
 ††Center Scale Trim
 †Scale Factor Trim
 *Copper Wire Wound

Figure 60. Logarithmic Light Sensor

System Examples (continued)

(Pin numbers are for 8-pin packages)

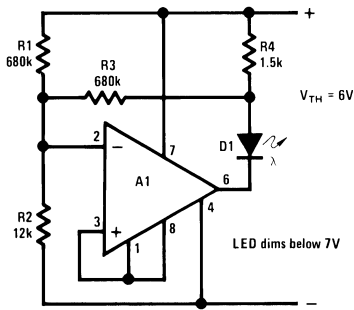

Figure 61. Battery-level Indicator

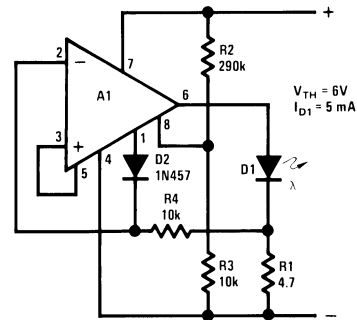
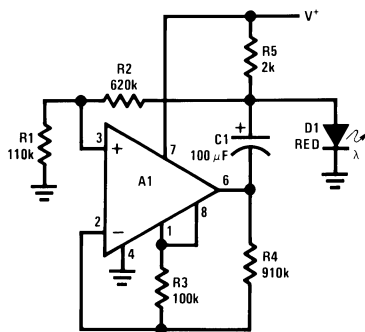
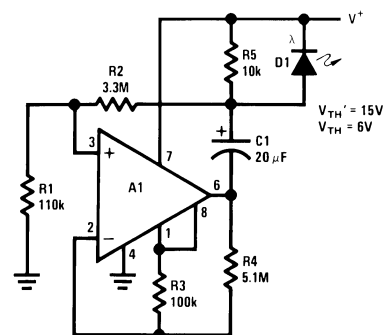

Figure 62. Battery-threshold Indicator



Flashes Above 1.2V
Rate Increases With
Voltage

Figure 63. Single-cell Voltage Monitor



Flash Rate Increases
Above 6V and Below 15V

Figure 64. Double-ended Voltage Monitor

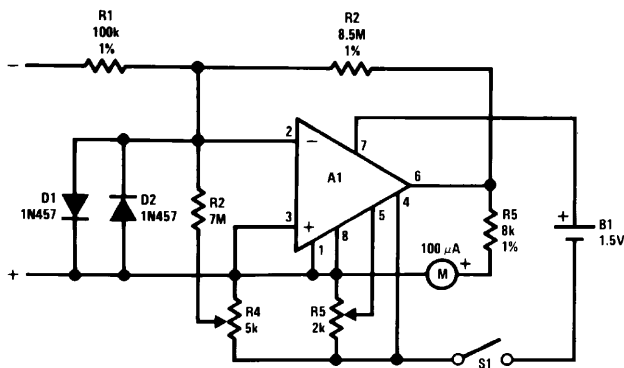

INPUT
10 mV, 100nA
FULL-SCALE

Figure 65. Meter Amplifier

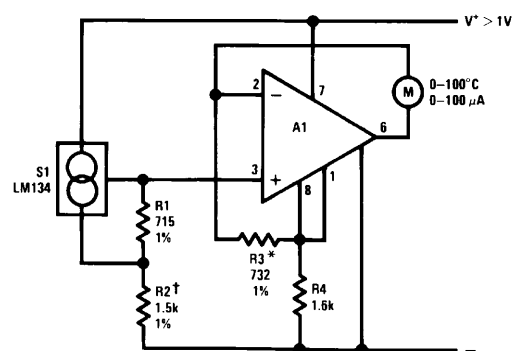

*Trim For Span
†Trim For Zero

Figure 66. Thermometer

System Examples (continued)

(Pin numbers are for 8-pin packages)

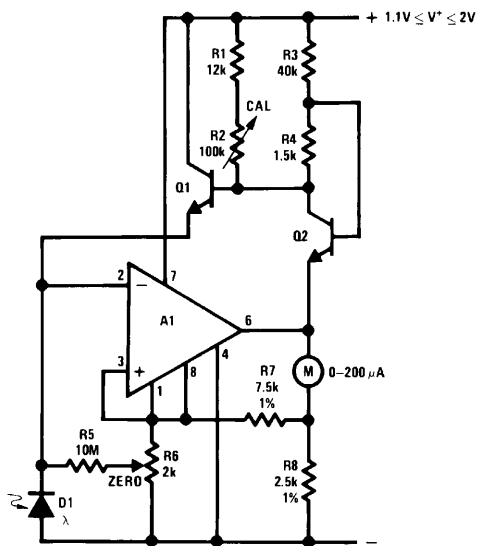

$1 \leq \lambda/\lambda_0 \leq 10^5$

Figure 67. Light Meter

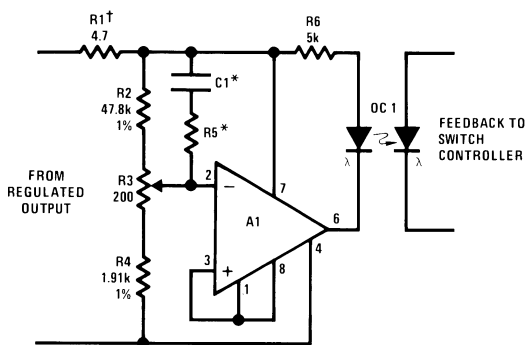

†Controls "Loop Gain"
*Optional Frequency Shaping

Figure 69. Isolated Voltage Sensor

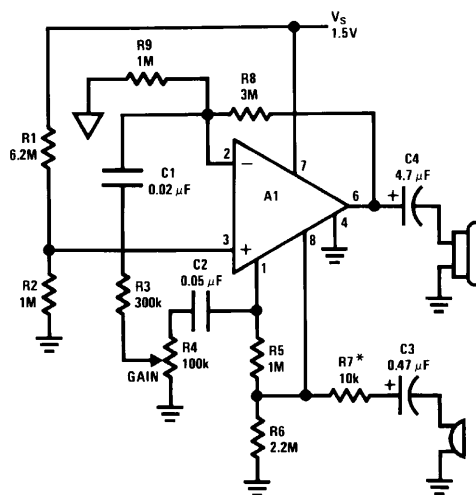

$Z_{OUT} \sim 680\Omega @ 5 \text{ kHz}$
 $A_V \leq 1k$
 $f_1 \sim 100 \text{ Hz}$
 $f_2 \sim 5 \text{ kHz}$
 $R_L \sim 500$
*Max Gain Trim

Figure 68. Microphone Amplifier

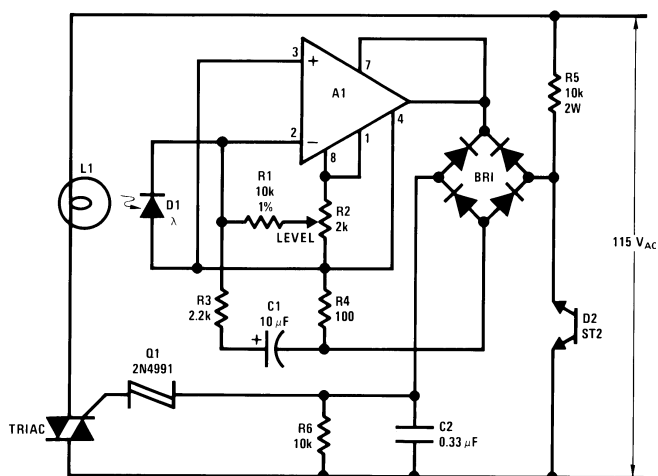

Figure 70. Light-Level Controller

System Examples (continued)

(Pin numbers are for 8-pin packages)

8.3.3 Reference and Internal Regulator

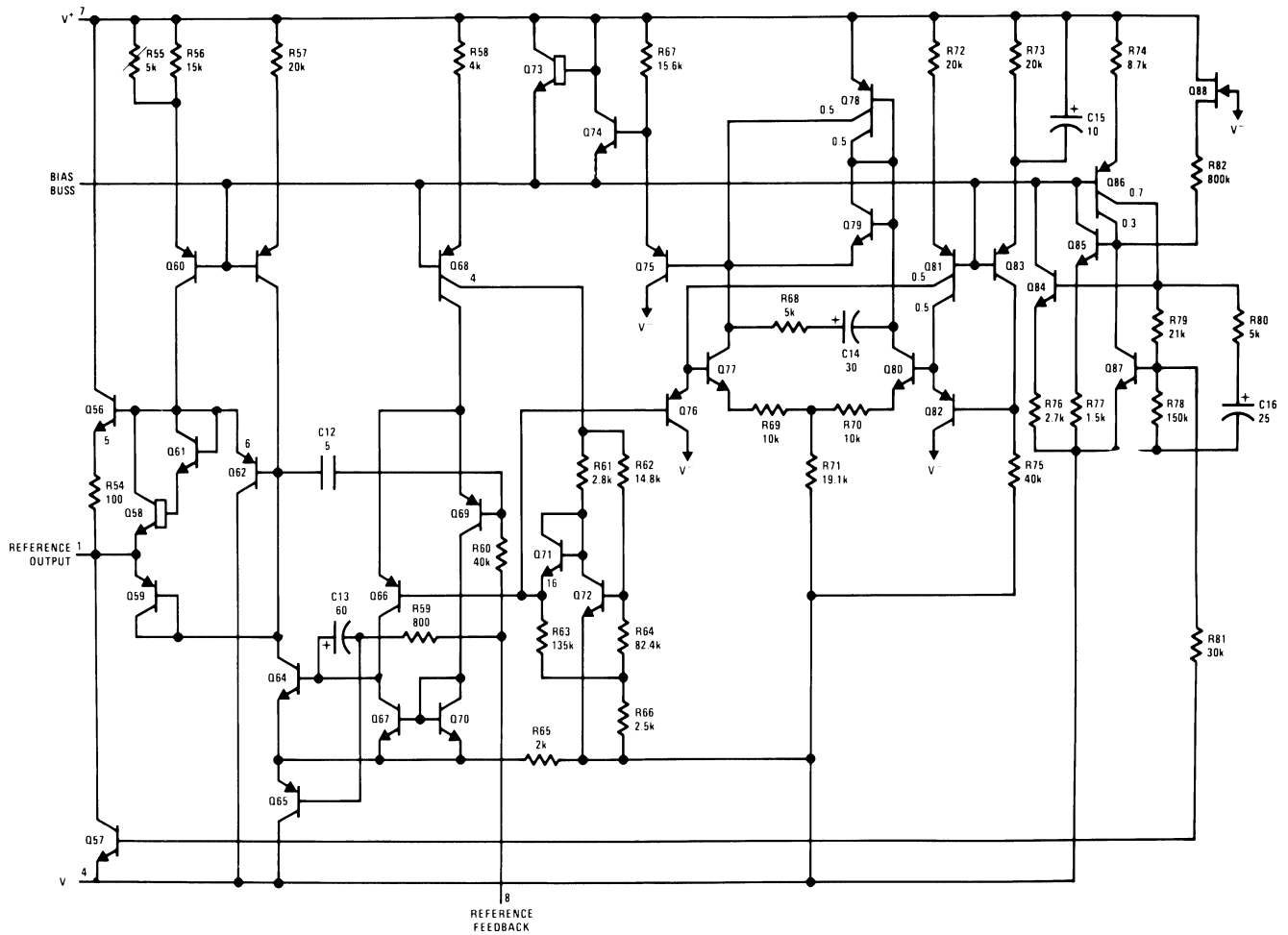

Figure 71. Reference and Internal Regulator

9 Power Supply Recommendations

The LM10-MIL is specified for operation from 1.2 V to 40 V unless otherwise stated. Many specifications apply from -55°C to 125°C . Parameters that can exhibit significant variance with regard to operating voltage or temperature are presented in the [Specifications](#) section.

CAUTION

Supply voltages larger than 40 V can permanently damage the device; see the [Absolute Maximum Ratings](#) table.

10 Layout

10.1 Layout Guidelines

For best operational performance of the device, good printed-circuit board (PCB) layout practices are recommended. Low-loss, 0.1- μF bypass capacitors should be connected between each supply pin and ground, placed as close to the device as possible. A single bypass capacitor from $V+$ to ground is applicable to single-supply applications.

10.2 Layout Example

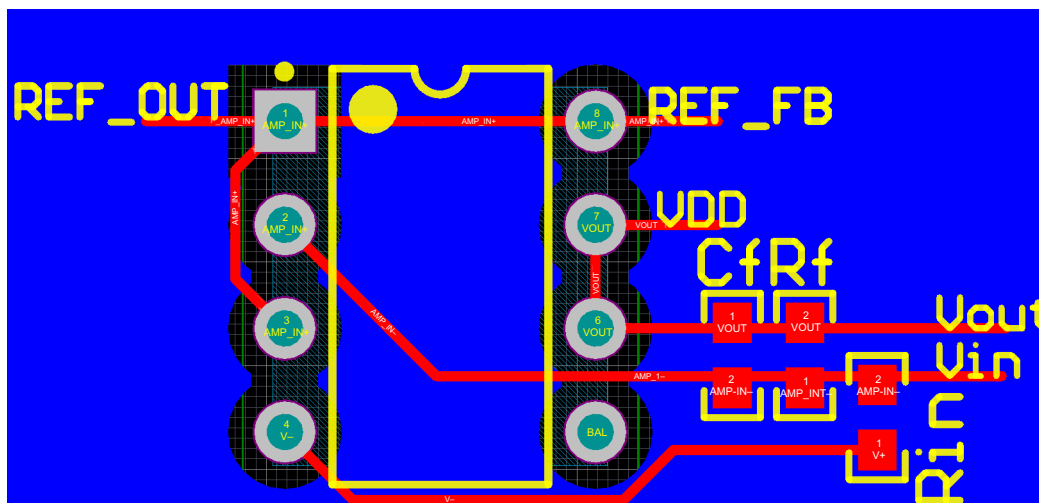

Figure 72. Layout Example

11 デバイスおよびドキュメントのサポート

11.1 デバイス・サポート

11.1.1 デバイスの関連用語

11.1.1.1 用語の定義

入力オフセット電圧: 無負荷時の出力を線形領域内にバイアスするため、入力端子間に印加する必要がある電圧。

入力オフセット電流: 無負荷時の出力が線形領域内にあるとき、入力端子における電流の差分。

入力バイアス電流: 2つの入力電流の平均の絶対値。

入力抵抗: 一方の入力端子が接地しているとき、もう一方の入力における入力電圧の変化と、入力電流の変化との比率。

大信号電圧ゲイン: 指定された出力電圧スイングと、それを生成するため必要な差動入力電圧の変化との比率。

シャント・ゲイン: 出力がICのV⁺端子に接続されているとき、指定された出力電圧スイングと、それを生成するため必要な差動入力電圧の変化との比率。負荷と電源はV⁺端子とV⁻端子との間に接続され、入力同相モードはV⁻端子を基準とします。

同相除去: 入力電圧範囲と、両極間のオフセット電圧変化との比率。

電源電圧除去: 指定された電源電圧変化と、両極間のオフセット電圧変化との比率。

ライン・レギュレーション: 指定された電源電圧範囲全体にわたる基準出力電圧の平均変化量。

負荷レギュレーション: 無負荷から、指定された負荷までにわたる基準出力電圧の変化。

帰還検知電圧: レギュレーション動作中の基準帰還端子の電圧で、V⁻を基準とします。

基準アンプ・ゲイン: 指定された基準出力電圧変化と、それを生成するために必要な帰還検知電圧の変化との比率。

帰還電流: レギュレーション動作中の、帰還端子における電流の絶対値。

消費電流: アンプと基準電圧の出力が無負荷で、線形範囲内で動作しているとき、アンプと基準電圧が動作するため電源から供給する必要がある電流。

11.2 ドキュメントのサポート

11.2.1 関連資料

関連資料については、以下を参照してください。

『AN-211 新しいオペアンプのアイデア』、[SNOA638](#)

11.3 コミュニティ・リソース

The following links connect to TI community resources. Linked contents are provided "AS IS" by the respective contributors. They do not constitute TI specifications and do not necessarily reflect TI's views; see TI's [Terms of Use](#).

TI E2E™ オンライン・コミュニティ TIのE2E (*Engineer-to-Engineer*) コミュニティ。エンジニア間の共同作業を促進するために開設されたものです。e2e.ti.comでは、他のエンジニアに質問し、知識を共有し、アイデアを検討して、問題解決に役立てることができます。

設計サポート TIの設計サポート役に立つE2Eフォーラムや、設計サポート・ツールをすばやく見つけることができます。技術サポート用の連絡先情報も参照できます。

11.4 商標

E2E is a trademark of Texas Instruments.

All other trademarks are the property of their respective owners.

11.5 静電気放電に関する注意事項



これらのデバイスは、限定的なESD(静電破壊)保護機能を内蔵しています。保存時または取り扱い時は、MOSゲートに対する静電破壊を防止するために、リード線同士をショートさせておくか、デバイスを導電フォームに入れる必要があります。

11.6 Glossary

[SLYZ022](#) — *TI Glossary*.

This glossary lists and explains terms, acronyms, and definitions.

12 メカニカル、パッケージ、および注文情報

以降のページには、メカニカル、パッケージ、および注文に関する情報が記載されています。この情報は、そのデバイスについて利用可能な最新のデータです。このデータは予告なく変更されることがあり、ドキュメントが改訂される場合もあります。本データシートのブラウザ版を使用されている場合は、画面左側の説明をご覧ください。

PACKAGING INFORMATION

Orderable part number	Status (1)	Material type (2)	Package Pins	Package qty Carrier	RoHS (3)	Lead finish/ Ball material (4)	MSL rating/ Peak reflow (5)	Op temp (°C)	Part marking (6)
LM10BH	Active	Production	TO-CAN (LMG) 8	500 TRAY NON-STD	No	Call TI	Level-1-NA-UNLIM	-40 to 85	(LM10BH, LM10BH)
LM10BH/NOPB	Active	Production	TO-CAN (LMG) 8	500 TRAY NON-STD	Yes	Call TI	Level-1-NA-UNLIM	-40 to 85	(LM10BH, LM10BH)
LM10CH	Active	Production	TO-CAN (LMG) 8	500 TRAY NON-STD	No	Call TI	Level-1-NA-UNLIM	0 to 70	(LM10CH, LM10CH)
LM10CH/NOPB	Active	Production	TO-CAN (LMG) 8	500 OTHER	Yes	Call TI	Level-1-NA-UNLIM	0 to 70	(LM10CH, LM10CH)

(1) **Status:** For more details on status, see our [product life cycle](#).

(2) **Material type:** When designated, preproduction parts are prototypes/experimental devices, and are not yet approved or released for full production. Testing and final process, including without limitation quality assurance, reliability performance testing, and/or process qualification, may not yet be complete, and this item is subject to further changes or possible discontinuation. If available for ordering, purchases will be subject to an additional waiver at checkout, and are intended for early internal evaluation purposes only. These items are sold without warranties of any kind.

(3) **RoHS values:** Yes, No, RoHS Exempt. See the [TI RoHS Statement](#) for additional information and value definition.

(4) **Lead finish/Ball material:** Parts may have multiple material finish options. Finish options are separated by a vertical ruled line. Lead finish/Ball material values may wrap to two lines if the finish value exceeds the maximum column width.

(5) **MSL rating/Peak reflow:** The moisture sensitivity level ratings and peak solder (reflow) temperatures. In the event that a part has multiple moisture sensitivity ratings, only the lowest level per JEDEC standards is shown. Refer to the shipping label for the actual reflow temperature that will be used to mount the part to the printed circuit board.

(6) **Part marking:** There may be an additional marking, which relates to the logo, the lot trace code information, or the environmental category of the part.

Multiple part markings will be inside parentheses. Only one part marking contained in parentheses and separated by a "~" will appear on a part. If a line is indented then it is a continuation of the previous line and the two combined represent the entire part marking for that device.

Important Information and Disclaimer: The information provided on this page represents TI's knowledge and belief as of the date that it is provided. TI bases its knowledge and belief on information provided by third parties, and makes no representation or warranty as to the accuracy of such information. Efforts are underway to better integrate information from third parties. TI has taken and continues to take reasonable steps to provide representative and accurate information but may not have conducted destructive testing or chemical analysis on incoming materials and chemicals. TI and TI suppliers consider certain information to be proprietary, and thus CAS numbers and other limited information may not be available for release.

In no event shall TI's liability arising out of such information exceed the total purchase price of the TI part(s) at issue in this document sold by TI to Customer on an annual basis.

PACKAGE OUTLINE

LMG0008A

TO-CAN - 5.72 mm max height

TRANSISTOR OUTLINE

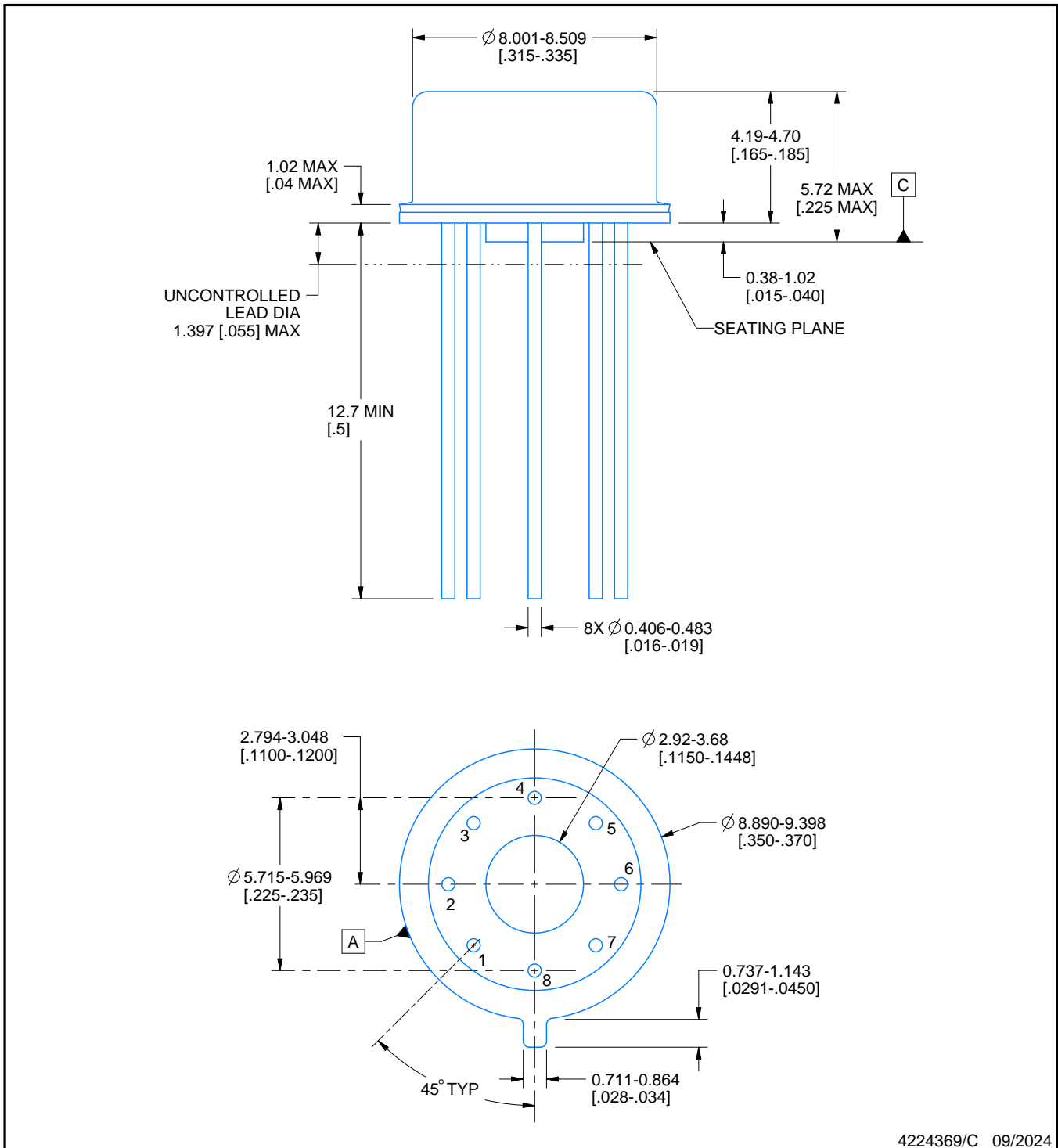

4224369/C 09/2024

NOTES:

1. All linear dimensions are in millimeters [inches]. Any dimensions in parenthesis are for reference only. Dimensioning and tolerancing per ASME Y14.5M.
2. This drawing is subject to change without notice.

EXAMPLE BOARD LAYOUT

LMG0008A

TO-CAN - 5.72 mm max height

TRANSISTOR OUTLINE

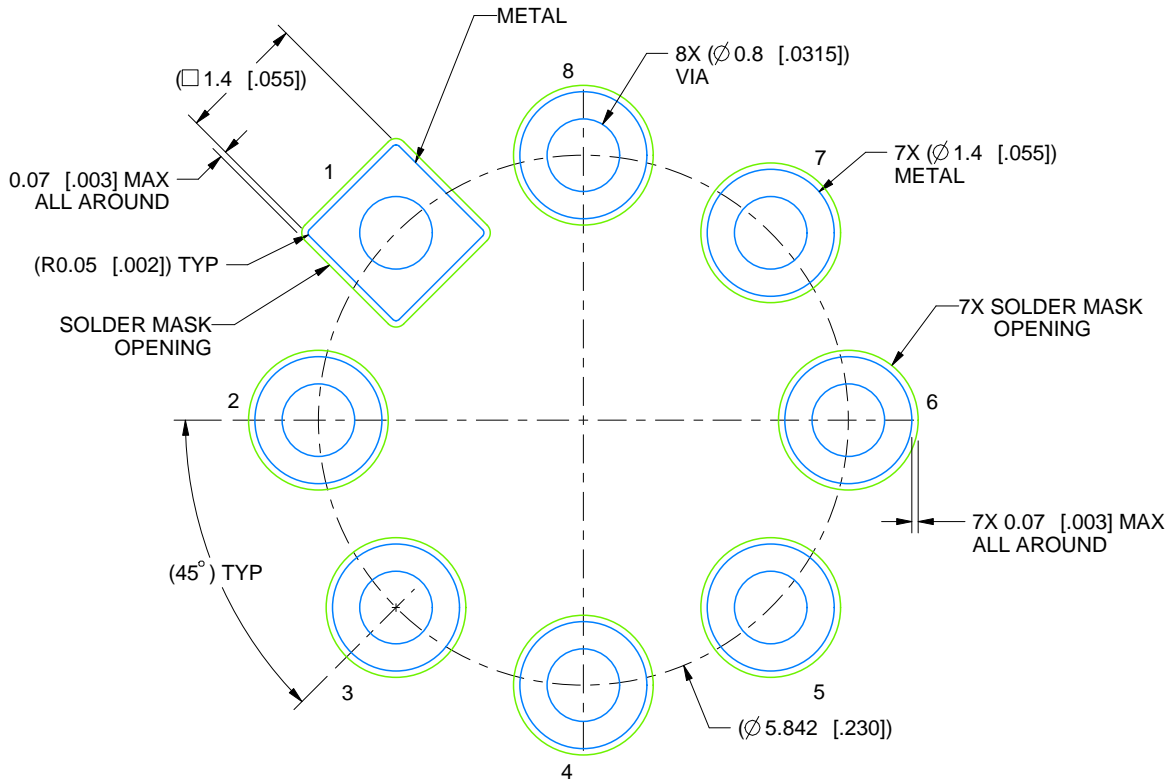

LAND PATTERN EXAMPLE
NON-SOLDER MASK DEFINED
SCALE: 12X

4224369/C 09/2024

重要なお知らせと免責事項

TI は、技術データと信頼性データ (データシートを含みます)、設計リソース (リファレンス デザインを含みます)、アプリケーションや設計に関する各種アドバイス、Web ツール、安全性情報、その他のリソースを、欠陥が存在する可能性のある「現状のまま」提供しており、商品性および特定目的に対する適合性の黙示保証、第三者の知的財産権の非侵害保証を含むいかなる保証も、明示的または黙示的にかかわらず拒否します。

これらのリソースは、TI 製品を使用する設計の経験を積んだ開発者への提供を意図したものです。(1) お客様のアプリケーションに適した TI 製品の選定、(2) お客様のアプリケーションの設計、検証、試験、(3) お客様のアプリケーションに該当する各種規格や、その他のあらゆる安全性、セキュリティ、規制、または他の要件への確実な適合に関する責任を、お客様のみが単独で負うものとし、

上記の各種リソースは、予告なく変更される可能性があります。これらのリソースは、リソースで説明されている TI 製品を使用するアプリケーションの開発の目的でのみ、TI はその使用をお客様に許諾します。これらのリソースに関して、他の目的で複製することや掲載することは禁止されています。TI や第三者の知的財産権のライセンスが付与されている訳ではありません。お客様は、これらのリソースを自身で使用した結果発生するあらゆる申し立て、損害、費用、損失、責任について、TI およびその代理人を完全に補償するものとし、TI は一切の責任を拒否します。

TI の製品は、[TI の販売条件](#)、[TI の総合的な品質ガイドライン](#)、[ti.com](#) または TI 製品などに関連して提供される他の適用条件に従い提供されます。TI がこれらのリソースを提供することは、適用される TI の保証または他の保証の放棄の拡大や変更を意味するものではありません。TI がカスタム、またはカスタマー仕様として明示的に指定していない限り、TI の製品は標準的なカタログに掲載される汎用機器です。

お客様がいかなる追加条項または代替条項を提案する場合も、TI はそれらに異議を唱え、拒否します。

Copyright © 2026, Texas Instruments Incorporated

最終更新日 : 2025 年 10 月