

LM2590HV SIMPLE SWITCHER®電力コンバータ、150kHz 1A降圧型電圧レギュレータ

1 特長

- 3.3V、5V、および可変出力のバージョン
- 可変タイプの出力電圧範囲1.2V~57V、入力と負荷の全条件で最大±4%の許容誤差
- 1Aの出力負荷電流を保証
- 7ピンのTO-220およびTO-263 (表面実装)パッケージで供給
- 最大60Vまでの入力電圧範囲
- 150kHz固定周波数の自己発振器
- シャットダウンおよびソフトスタート
- レギュレーション範囲外エラー・フラグ
- エラー・フラグ遅延
- 低消費電力のスタンバイ・モード、 I_Q の標準値90 μ A
- 高効率
- サーマル・シャットダウンおよび電流制限保護

2 アプリケーション

- シンプルな高効率降圧型(バック)レギュレータ
- リニア・レギュレータ用の高効率プリレギュレータ
- オンカードのスイッチング・レギュレータ
- 正負反転コンバータ

3 概要

この LM2590HV シリーズのレギュレータは、モノリシックな集積回路で、降圧型(バック)スイッチング・レギュレータのすべてのアクティブ機能を提供し、優れたラインおよび負荷レギュレーションで1Aの負荷を駆動できます。これらのデバイスは、3.3Vおよび5Vの固定出力電圧と、可変出力バージョンで利用可能です。

このシリーズのスイッチング・レギュレータはLM2591HVと類似ですが、監視機能や制御機能が追加されています。

これらのレギュレータは、必要な外付け部品数が最小限で、使いやすく、内部的な周波数補正、ラインおよび負荷仕様の強化、固定周波数発振器、シャットダウン/ソフトスタート、出力エラー・フラグ、フラグ遅延の機能を備えています。

LM2590HVは150kHzのスイッチング周波数で動作するため、低周波数で動作するスイッチング・レギュレータと比較して、サイズの小さいフィルタ部品を使用できます。標準的な7ピンのTO-220パッケージで、いくつかの異なるリードフォーミング品で供給されるほか、7ピンのTO-263表面実装パッケージでも供給されます。

他の特長として、入力電圧と出力負荷のあらゆる条件において、出力電圧について±4%、発振器の周波数について±15%の許容誤差が保証されています。外部シャットダウン機能を備え、スタンバイ電流は標準値で90 μ Aです。自己保護機能として、出力スイッチには2段階の電流制限回路が搭載されており、フォルト状況では過熱シャットダウンにより完全な保護が行われます。

製品情報⁽¹⁾

型番	パッケージ	本体サイズ(公称)
LM2590HV	TO-220 (7)	14.99mm×10.16mm
	TO-263 (7)	10.10mm×8.89mm

(1) 提供されているすべてのパッケージについては、巻末の注文情報を参照してください。

代表的なアプリケーション (固定出力電圧バージョン)

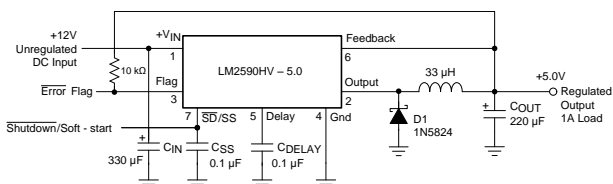

Copyright © 2016, Texas Instruments Incorporated



目次

1	特長	1	8.2	Functional Block Diagram	15
2	アプリケーション	1	8.3	Feature Description	15
3	概要	1	8.4	Device Functional Modes	18
4	改訂履歴	2	9	Application and Implementation	19
5	Pin Configuration and Functions	3	9.1	Application Information	19
6	Specifications	5	9.2	Typical Application	21
6.1	Absolute Maximum Ratings	5	10	Power Supply Recommendations	25
6.2	ESD Ratings	5	11	Layout	25
6.3	Recommended Operating Conditions	5	11.1	Layout Guidelines	25
6.4	Thermal Information	5	11.2	Layout Examples	25
6.5	Electrical Characteristics	6	11.3	Thermal Considerations	26
6.6	Electrical Characteristics – 3.3-V Version	7	12	デバイスおよびドキュメントのサポート	28
6.7	Electrical Characteristics – 5-V Version	7	12.1	ドキュメントのサポート	28
6.8	Electrical Characteristics – Adjustable Version	7	12.2	ドキュメントの更新通知を受け取る方法	28
6.9	Typical Characteristics	9	12.3	コミュニティ・リソース	28
7	Parameter Measurement Information	13	12.4	商標	28
7.1	Test Circuits	13	12.5	静電気放電に関する注意事項	28
8	Detailed Description	15	12.6	Glossary	28
8.1	Overview	15	13	メカニカル、パッケージ、および注文情報	28

4 改訂履歴

Revision B (December 2001) から Revision C に変更

Page

• 「ESD定格」の表、「機能説明」セクション、「デバイスの機能モード」セクション、「アプリケーションと実装」セクション、「電源に関する推奨事項」セクション、「レイアウト」セクション、「デバイスおよびドキュメントのサポート」セクション、「メカニカル、パッケージ、および注文情報」セクションを追加	1
---	---

5 Pin Configuration and Functions

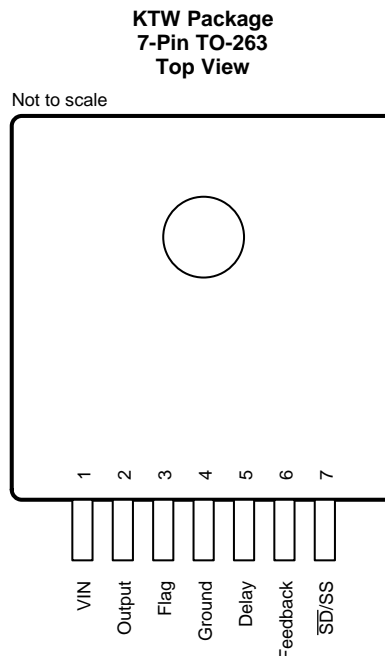
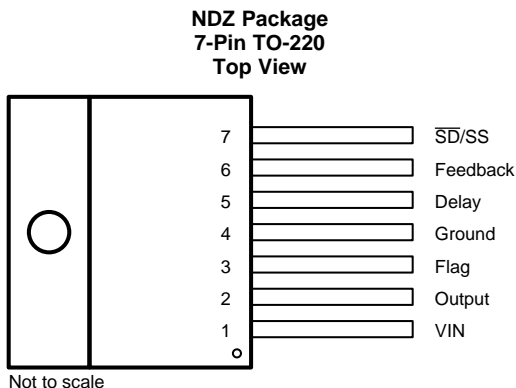

Pin Functions

PIN		TYPE ⁽¹⁾	DESCRIPTION
NO.	NAME		
1	V _{IN}	I	This is the positive input supply for the IC switching regulator. A suitable input bypass capacitor must be present at this pin to minimize voltage transients and to supply the switching currents needed by the regulator.
2	Output	O	Internal switch. The voltage at this pin switches between approximately (+V _{IN} – V _{SAT}) and approximately –0.5 V, with a duty cycle of V _{OUT} /V _{IN} .
3	Flag	O	Open collector output that goes active low (≤ 1 V) when the output of the switching regulator is out of regulation (less than 95% of its nominal value). In this state it can sink maximum 3 mA. When not low, it can be pulled high to signal that the output of the regulator is in regulation (power good). During power-up, it can be programmed to go high after a certain delay as set by the Delay pin (Pin 5). The maximum rating of this pin must not be exceeded, so if the rail to which it will be pulled-up to is higher than 45 V, a resistive divider must be used instead of a single pull-up resistor, as indicated in Test Circuits .
4	Ground	G	Circuit ground
5	Delay	O	This sets a programmable power-up delay from the moment that the output reaches regulation, to the high signal output (power good) on Pin 3. A capacitor on this pin starts charging up by means on an internal (3 μ A) current source when the regulated output rises to within 5% of its nominal value. Pin 3 goes high (with an external pull-up) when the voltage on the capacitor on Pin 5 exceeds 1.3 V. The voltage on this pin is clamped internally to about 1.7 V. If the regulated output drops out of regulation (less than 95% of its nominal value), the capacitor on Pin 5 is rapidly discharged internally and Pin 3 will be forced low in about 1/1000th of the set power-up delay time.
6	Feedback	I	Senses the regulated output voltage to complete the feedback loop. This pin is directly connected to the Output for the fixed voltage versions, but is set to 1.23 V by means of a resistive divider from the output for the adjustable version. If a feedforward capacitor is used (adjustable version), then a negative voltage spike is generated on this pin whenever the output is shorted. This happens because the feedforward capacitor cannot discharge fast enough, and since one end of it is dragged to Ground, the other end goes momentarily negative. To prevent the energy rating of this pin from being exceeded, a small-signal Schottky diode to Ground is recommended for DC input voltages above 40 V whenever a feedforward capacitor is present (see Test Circuits). Feedforward capacitor values larger than 0.1 μ F are not recommended for the same reason, whatever be the DC input voltage.

(1) G = Ground, I = Input, O = Output

Pin Functions (continued)

PIN		TYPE ⁽¹⁾	DESCRIPTION
NO.	NAME		
7	$\overline{SD/SS}$	I	<p>Shutdown/Soft-start: The regulator is in shutdown mode, drawing about 90 μA, when this pin is driven to a low level (≤ 0.6 V), and is in normal operation when this Pin is left floating (internal-pullup) or driven to a high level (≥ 2 V). The typical value of the threshold is 1.3 V and the pin is internally clamped to a maximum of about 7 V. If it is driven higher than the clamp voltage, it must be ensured by means of an external resistor that the current into the pin does not exceed 1 mA. The duty cycle is minimum (0%) if this Pin is below 1.8 V, and increases as the voltage on the pin is increased. The maximum duty cycle (100%) occurs when this pin is at 2.8 V or higher. So adding a capacitor to this pin produces a soft-start feature. An internal current source will charge the capacitor from zero to its internally clamped value. The charging current is about 5 μA when the pin is below 1.3 V but is reduced to only 1.6 μA above 1.3 V, so as to allow the use of smaller soft-start capacitors.</p>

6 Specifications

6.1 Absolute Maximum Ratings

over operating free-air temperature range (unless otherwise noted)⁽¹⁾

			MIN	MAX	UNIT
Supply voltage, V_{IN}				63	V
\overline{SD}/SS pin input voltage ⁽²⁾				6	V
Delay pin voltage ⁽²⁾				1.5	V
Flag pin voltage			-0.3	45	V
Feedback pin voltage			-0.3	25	V
Output voltage to ground, steady-state				-1	V
Power dissipation			Internally limited		
Lead temperature	S package	Vapor phase (60 s)		215	°C
		Infrared (10 s)		245	
	T package, soldering (10 s)		260		
Maximum junction temperature				150	°C
Storage temperature, T_{stg}			-65	150	°C

- (1) Stresses beyond those listed under *Absolute Maximum Ratings* may cause permanent damage to the device. These are stress ratings only, which do not imply functional operation of the device at these or any other conditions beyond those indicated under *Recommended Operating Conditions*. Exposure to absolute-maximum-rated conditions for extended periods may affect device reliability.
- (2) Voltage internally clamped. If clamp voltage is exceeded, limit current to a maximum of 1 mA.

6.2 ESD Ratings

			VALUE	UNIT
V_{ESD}	Electrostatic discharge	Human-body model (HBM), per ANSI/ESDA/JEDEC JS-001 ⁽¹⁾	±2000	V

- (1) JEDEC document JEP155 states that 500-V HBM allows safe manufacturing with a standard ESD control process.

6.3 Recommended Operating Conditions

over operating free-air temperature range (unless otherwise noted)

			MIN	MAX	UNIT
Supply voltage			4.5	60	V
T_J	Temperature		-40	125	°C

6.4 Thermal Information

THERMAL METRIC ⁽¹⁾		LM2590HV		UNIT
		NDZ (TO-220)	KTW (TO-263)	
		7 PINS	7 PINS	
$R_{\theta JA}$	Junction-to-ambient thermal resistance	See ⁽²⁾	50	°C/W
		See ⁽³⁾	—	
		See ⁽⁴⁾	50	
		See ⁽⁵⁾	30	
$R_{\theta JC}$	Junction-to-case thermal resistance	—	20	°C/W
		2	2	

- (1) For more information about traditional and new thermal metrics, see the [Semiconductor and IC Package Thermal Metrics](#) application report.
- (2) Junction to ambient thermal resistance (no external heat sink) for the package mounted TO-220 package mounted vertically, with the leads soldered to a printed-circuit board with (1 oz.) copper area of approximately 1 in².
- (3) Junction to ambient thermal resistance with the TO-263 package tab soldered to a single sided printed-circuit board with 0.5 in² of (1 oz.) copper area.
- (4) Junction to ambient thermal resistance with the TO-263 package tab soldered to a single sided printed-circuit board with 2.5 in² of (1 oz.) copper area.
- (5) Junction to ambient thermal resistance with the TO-263 package tab soldered to a double sided printed circuit board with 3 in 2 of (1 oz.) copper area on the LM2590HVS side of the board, and approximately 16 in² of copper on the other side of the PCB. See [Application Information](#) in this data sheet.

6.5 Electrical Characteristics

 $T_J = 25^\circ\text{C}$, $V_{IN} = 12\text{ V}$ for the 3.3-V, 5-V, and adjustable version, and $I_{LOAD} = 500\text{ mA}$ (unless otherwise noted)

PARAMETER		TEST CONDITIONS		MIN ⁽¹⁾	TYP ⁽²⁾	MAX ⁽¹⁾	UNIT
I_b	Feedback bias current	Adjustable version only, $V_{FB} = 1.3\text{ V}$	$T_J = 25^\circ\text{C}$	10	50		nA
			$T_J = -40^\circ\text{C to } 125^\circ\text{C}$			100	
f_O	Oscillator frequency ⁽³⁾		$T_J = 25^\circ\text{C}$	127	150	173	kHz
			$T_J = -40^\circ\text{C to } 125^\circ\text{C}$	110		173	
V_{SAT}	Saturation voltage		$I_{OUT} = 1\text{ A}$ ⁽⁴⁾⁽⁵⁾	1.2	0.95	1.3	V
DC	Max duty cycle (ON) ⁽⁵⁾			100%			
	Min duty cycle (OFF) ⁽⁶⁾			0%			
I_{CLIM}	Switch current limit	Peak current ⁽⁴⁾⁽⁵⁾	$T_J = 25^\circ\text{C}$	1.3	1.9	2.8	A
			$T_J = -40^\circ\text{C to } 125^\circ\text{C}$	1.2		3	
I_L	Output leakage current	$V_{IN} = 60\text{ V}$ ⁽⁴⁾⁽⁶⁾	Output = 0 V			50	μA
			Output = -1 V		5	30	mA
I_Q	Operating quiescent current		$\overline{SD/SS}$ pin open ⁽⁶⁾		5	10	mA
I_{STBY}	Standby quiescent current	$\overline{SD/SS}$ pin = 0 V, $V_{IN} = 60\text{ V}$	$T_J = 25^\circ\text{C}$		90	200	μA
			$T_J = -40^\circ\text{C to } 125^\circ\text{C}$			250	
SHUTDOWN AND SOFT-START CONTROL (see Test Circuits)							
V_{SD}	Shutdown threshold voltage		$T_J = 25^\circ\text{C}$		1.3		V
			$T_J = -40^\circ\text{C to } 125^\circ\text{C}$	Low (shutdown mode)		0.6	
				High (soft-start mode)	2		
V_{SS}	Soft-start voltage		$V_{OUT} = 20\%$ of nominal output voltage		2		V
			$V_{OUT} = 100\%$ of nominal output voltage		3		
I_{SD}	Shutdown current		$\overline{V_{SHUTDOWN}} = 0.5\text{ V}$		5	10	μA
I_{SS}	Soft-start current		$V_{\text{Soft-start}} = 2.5\text{ V}$		1.5	5	μA
FLAG AND DELAY CONTROL (see Test Circuits)							
	Regulator dropout detector threshold voltage		Low (flag ON)	92%	96%	98%	
V_{FSAT}	Flag output saturation and voltage		$I_{SINK} = 3\text{ mA}$	0.7	0.3	1	V
I_{FL}	Flag output leakage current		$V_{FLAG} = 60\text{ V}$		0.3		μA
	Delay pin threshold voltage		Low (flag ON)	1.21	1.25		mV
			High (flag OFF) and V_{OUT} regulated		1.25	1.29	
	Delay pin source current		$V_{DELAY} = 0.5\text{ V}$		3	6	mV
	Delay pin saturation		Low (flag ON)	$T_J = 25^\circ\text{C}$	70	350	mV
				$T_J = -40^\circ\text{C to } 125^\circ\text{C}$			

- All limits specified at room temperature and at temperature extremes. All room temperature limits are 100% production tested. All limits at temperature extremes are specified via correlation using standard Statistical Quality Control (SQC) methods. All limits are used to calculate Average Outgoing Quality Level (AOQL).
- Typical numbers are at 25°C and represent the most likely norm.
- The switching frequency is reduced when the second stage current limit is activated. The amount of reduction is determined by the severity of current overload.
- No diode, inductor or capacitor connected to output pin.
- Feedback pin removed from output and connected to 0 V to force the output transistor switch ON.
- Feedback pin removed from output and connected to 12 V for the 3.3-V, 5-V, and the ADJ version to force the output transistor switch OFF.

6.6 Electrical Characteristics – 3.3-V Version

 $T_J = 25^\circ\text{C}$ (unless otherwise noted)⁽¹⁾

PARAMETER	TEST CONDITIONS	MIN ⁽²⁾	TYP ⁽³⁾	MAX ⁽²⁾	UNIT	
V_{OUT} Output voltage	$4.5\text{ V} \leq V_{IN} \leq 60\text{ V}$, $0.2\text{ A} \leq I_{LOAD} \leq 1\text{ A}$	$T_J = 25^\circ\text{C}$	3.168	3.3	3.432	V
		$T_J = -40^\circ\text{C}$ to 125°C	3.135		3.465	
η Efficiency	$V_{IN} = 12\text{ V}$, $I_{LOAD} = 1\text{ A}$	77%				

- (1) External components such as the catch diode, inductor, input and output capacitors can affect switching regulator system performance. When the LM2590HV is used as shown in [Test Circuits](#), system performance will be as shown in system parameters section of [Electrical Characteristics](#).
- (2) All limits specified at room temperature and at temperature extremes. All room temperature limits are 100% production tested. All limits at temperature extremes are specified via correlation using standard Statistical Quality Control (SQC) methods. All limits are used to calculate Average Outgoing Quality Level (AOQL).
- (3) Typical numbers are at 25°C and represent the most likely norm.

6.7 Electrical Characteristics – 5-V Version

 $T_J = 25^\circ\text{C}$ (unless otherwise noted)⁽¹⁾

PARAMETER	TEST CONDITIONS	MIN ⁽²⁾	TYP ⁽³⁾	MAX ⁽²⁾	UNIT	
V_{OUT} Output voltage	$7\text{ V} \leq V_{IN} \leq 60\text{ V}$, $0.2\text{ A} \leq I_{LOAD} \leq 1\text{ A}$	$T_J = 25^\circ\text{C}$	4.8	5	5.2	V
		$T_J = -40^\circ\text{C}$ to 125°C	4.75		5.25	
η Efficiency	$V_{IN} = 12\text{ V}$, $I_{LOAD} = 1\text{ A}$	82%				

- (1) External components such as the catch diode, inductor, input and output capacitors can affect switching regulator system performance. When the LM2590HV is used as shown in [Test Circuits](#), system performance will be as shown in system parameters section of [Electrical Characteristics](#).
- (2) All limits specified at room temperature and at temperature extremes. All room temperature limits are 100% production tested. All limits at temperature extremes are specified via correlation using standard Statistical Quality Control (SQC) methods. All limits are used to calculate Average Outgoing Quality Level (AOQL).
- (3) Typical numbers are at 25°C and represent the most likely norm.

6.8 Electrical Characteristics – Adjustable Version

 $T_J = 25^\circ\text{C}$ (unless otherwise noted)⁽¹⁾

PARAMETER	TEST CONDITIONS	MIN ⁽²⁾	TYP ⁽³⁾	MAX ⁽²⁾	UNIT	
V_{FB} Feedback voltage	$4.5\text{ V} \leq V_{IN} \leq 60\text{ V}$, $0.2\text{ A} \leq I_{LOAD} \leq 1\text{ A}$, V_{OUT} programmed for 3 V (see Test Circuits)	$T_J = 25^\circ\text{C}$	1.193	1.23	1.267	V
		$T_J = -40^\circ\text{C}$ to 125°C	1.18		1.28	
η Efficiency	$V_{IN} = 12\text{ V}$, $V_{OUT} = 3\text{ V}$, $I_{LOAD} = 1\text{ A}$	76%				

- (1) External components such as the catch diode, inductor, input and output capacitors can affect switching regulator system performance. When the LM2590HV is used as shown in [Test Circuits](#), system performance will be as shown in system parameters section of [Electrical Characteristics](#).
- (2) All limits specified at room temperature and at temperature extremes. All room temperature limits are 100% production tested. All limits at temperature extremes are specified via correlation using standard Statistical Quality Control (SQC) methods. All limits are used to calculate Average Outgoing Quality Level (AOQL).
- (3) Typical numbers are at 25°C and represent the most likely norm.

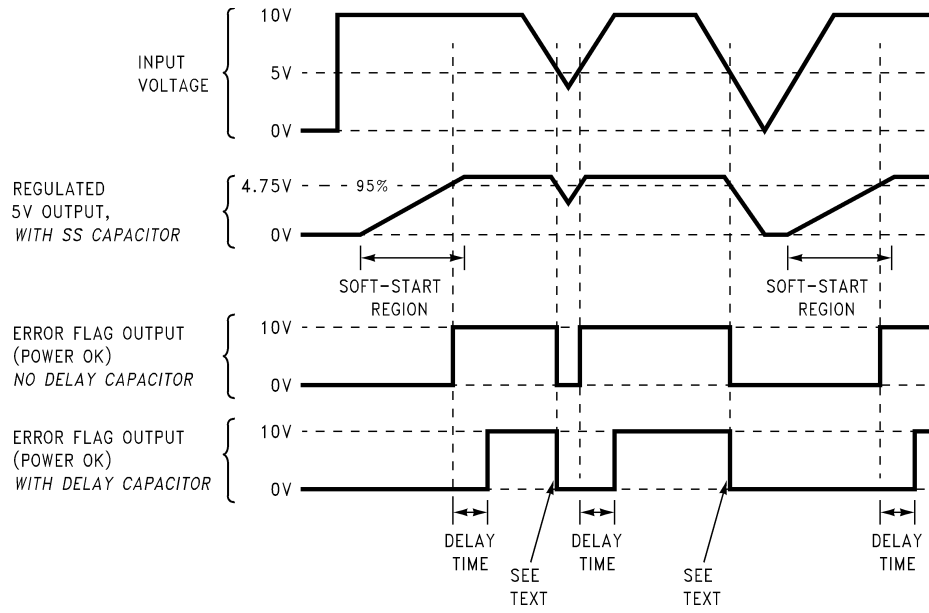

Figure 1. Timing Diagram for 5-V Output

6.9 Typical Characteristics

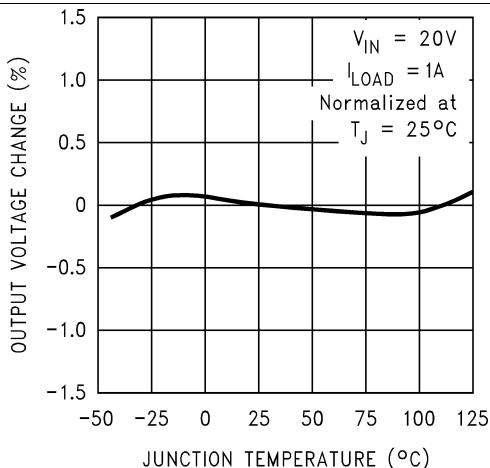

Figure 2. Normalized Output Voltage

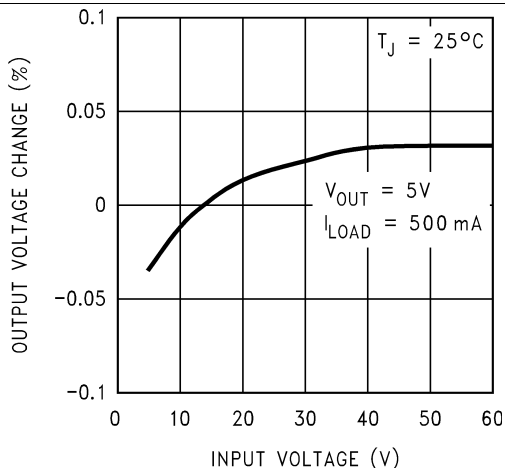

Figure 3. Line Regulation

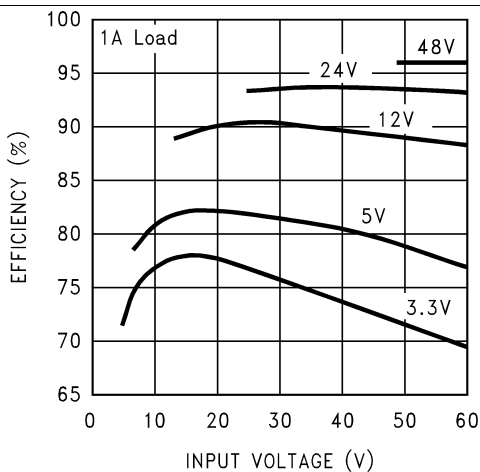

Figure 4. Efficiency

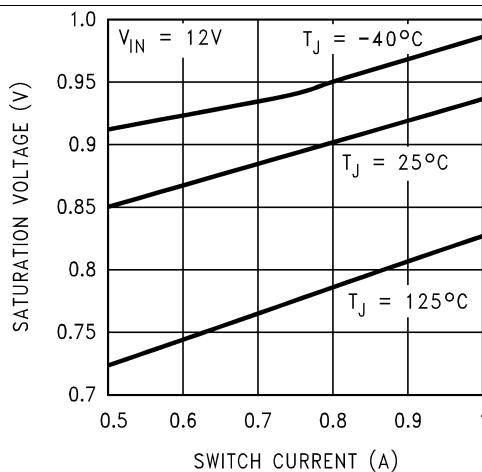

Figure 5. Switch Saturation Voltage

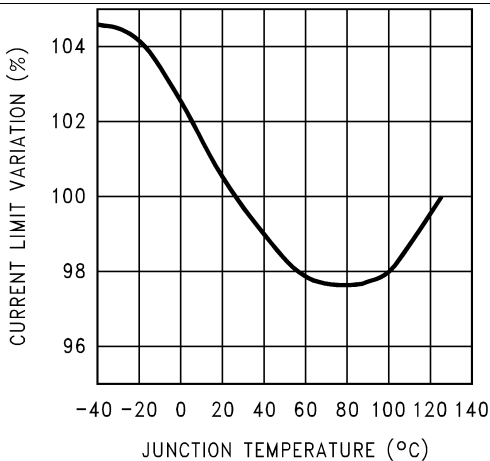

Figure 6. Switch Current Limit

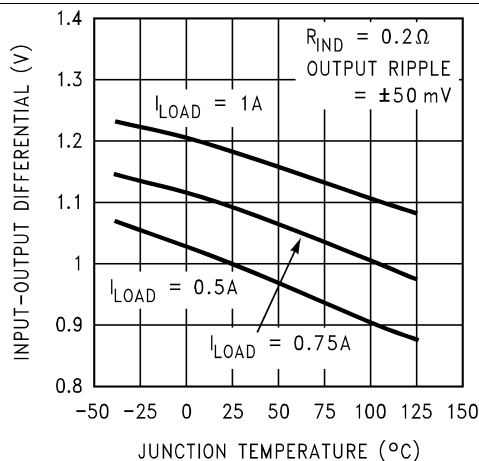

Figure 7. Dropout Voltage

Typical Characteristics (continued)

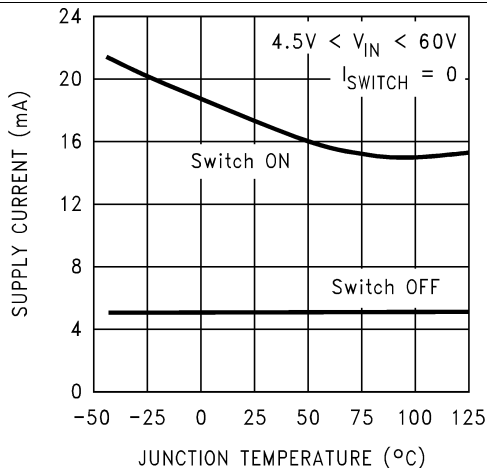

Figure 8. Operating Quiescent Current

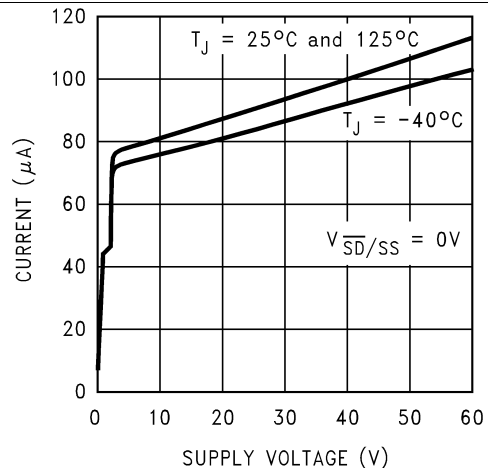

Figure 9. Shutdown Quiescent Current

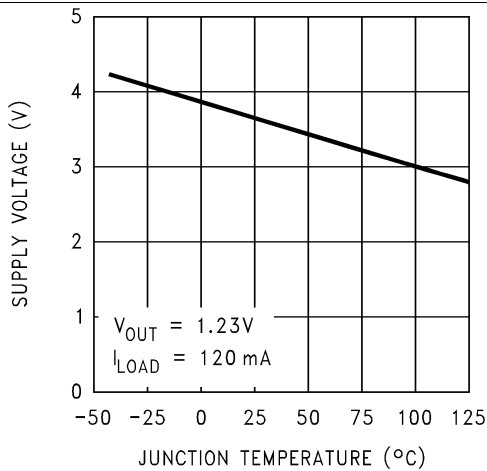

Figure 10. Minimum Operating Supply Voltage

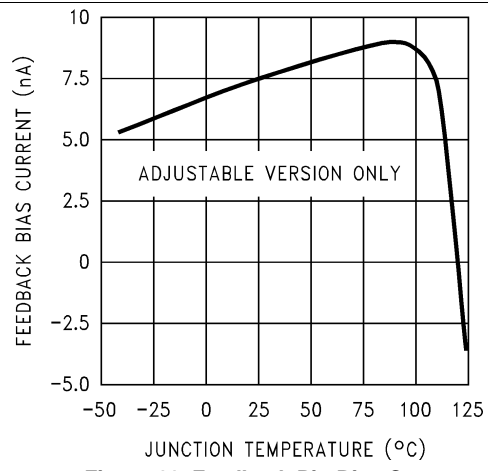

Figure 11. Feedback Pin Bias Current

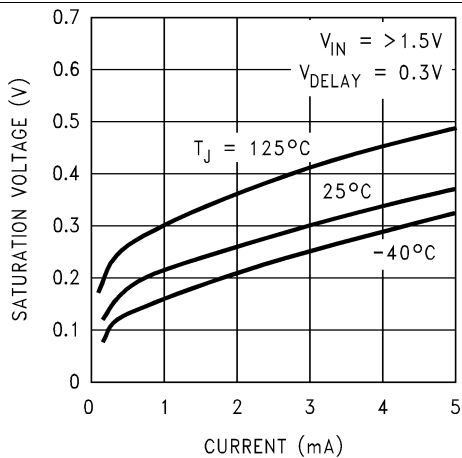

Figure 12. Flag Saturation Voltage

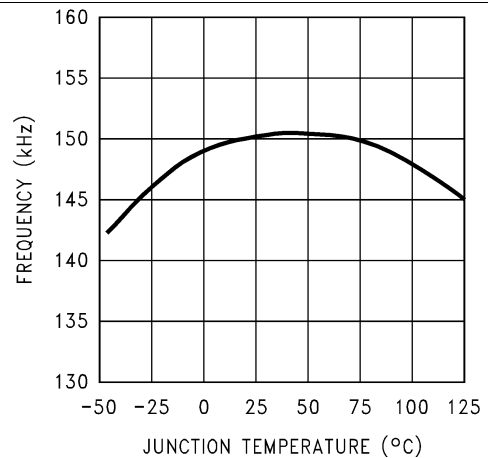

Figure 13. Switching Frequency

Typical Characteristics (continued)

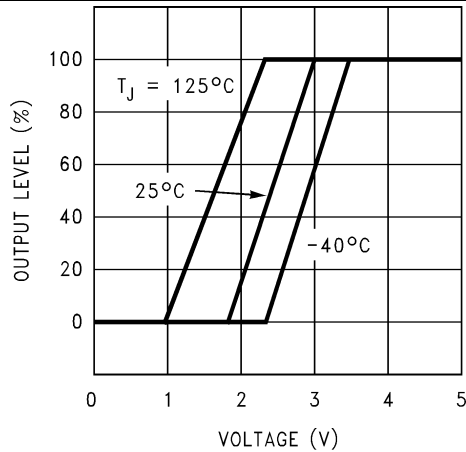

Figure 14. Soft-Start

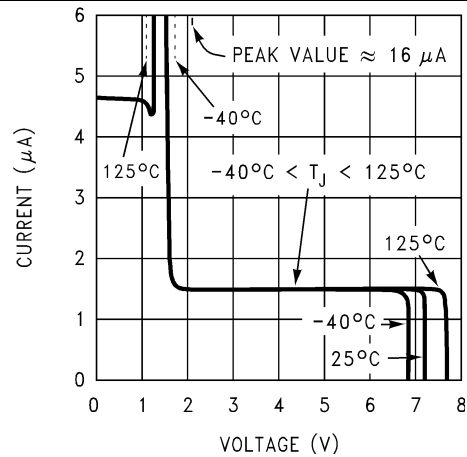

Figure 15. Shutdown/Soft-Start Current

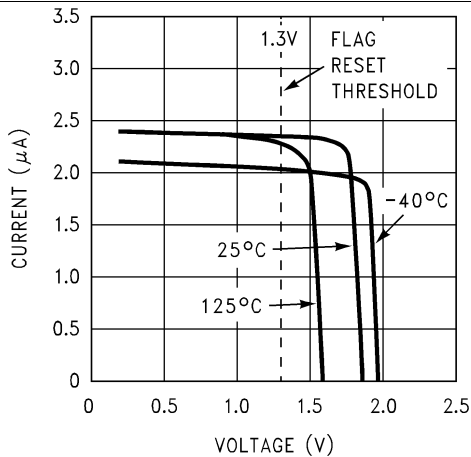

Figure 16. Delay Pin Current

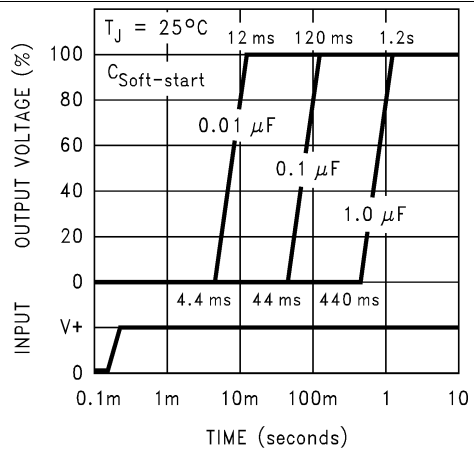

Figure 17. Soft-Start Response

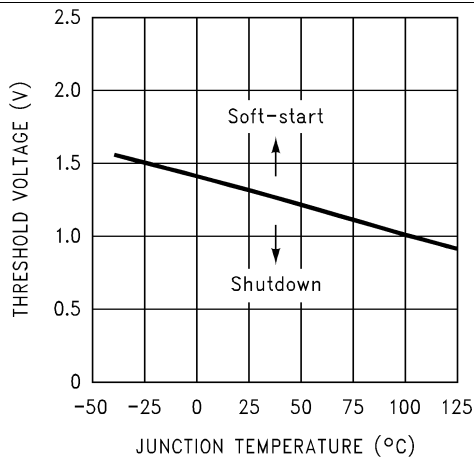

Figure 18. Shutdown/Soft-start Threshold Voltage

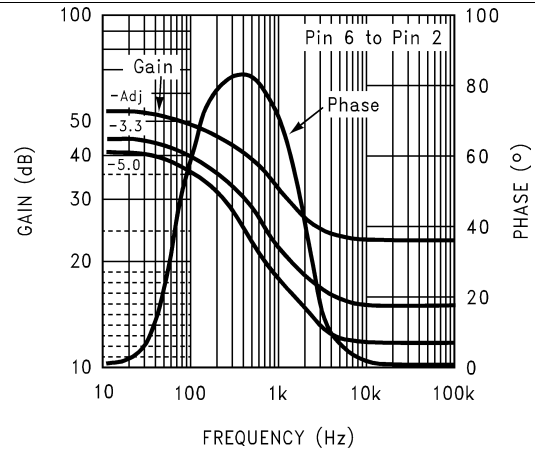
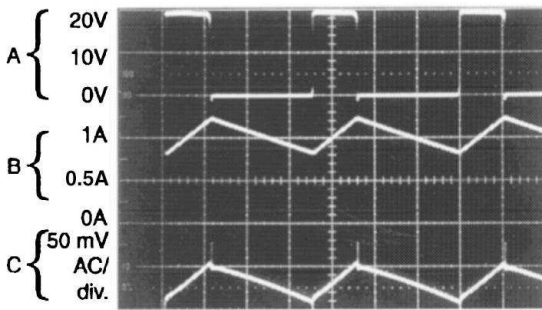
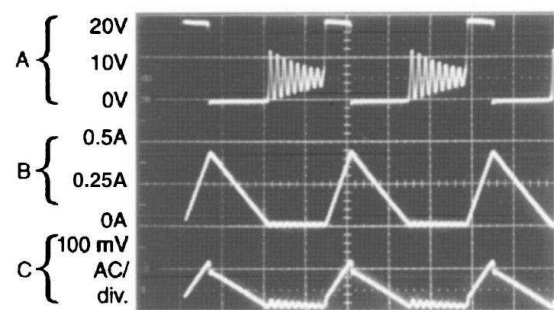

Figure 19. Internal Gain-Phase Characteristics

Typical Characteristics (continued)

Horizontal Time Base: 2 μ s/div.
 $V_{IN} = 20$ V, $V_{OUT} = 5$ V, $I_{LOAD} = 1$ A,
 $L = 52$ μ H, $C_{OUT} = 100$ μ F, C_{OUT} ESR = 100 m Ω
 Output Pin Voltage, 10 V/div.
 Inductor Current, 0.5 A/div.
 Output Ripple Voltage, 50 mV/div.

Figure 20. Continuous Mode Switching Waveforms

Horizontal Time Base: 2 μ s/div.
 $V_{IN} = 20$ V, $V_{OUT} = 5$ V, $I_{LOAD} = 250$ mA,
 $L = 52$ μ H, $C_{OUT} = 150$ μ F, C_{OUT} ESR = 100 m Ω
 Output Pin Voltage, 10 V/div.
 Inductor Current, 0.25 A/div.
 Output Ripple Voltage, 100 mV/div.

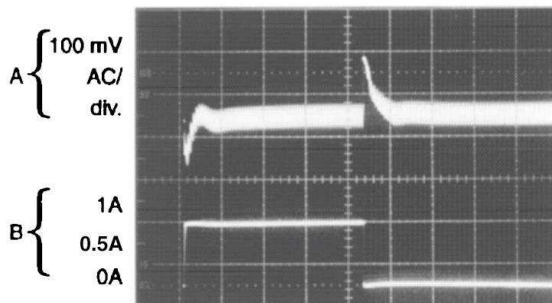
Figure 21. Discontinuous Mode Switching Waveforms

Horizontal Time Base: 50 μ s/div.
 $V_{IN} = 20$ V, $V_{OUT} = 5$ V, $I_{LOAD} = 250$ mA,
 $L = 52$ μ H, $C_{OUT} = 100$ μ F, C_{OUT} ESR = 100 m Ω
 Output Voltage, 100 mV/div. (AC)
 250-mA to 1-A Load Pulse

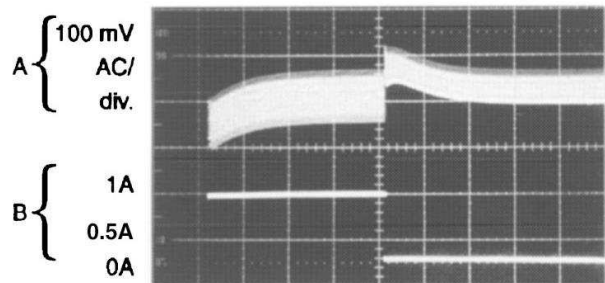
**Figure 22. Load Transient Response
for Continuous Mode**

Horizontal Time Base: 200 μ s/div.
 $V_{IN} = 20$ V, $V_{OUT} = 5$ V, $I_{LOAD} = 250$ mA to 1 A,
 $L = 15$ μ H, $C_{OUT} = 150$ μ F, C_{OUT} ESR = 90 m Ω
 Output Voltage, 100 mV/div. (AC)
 250-mA to 1-A Load Pulse

**Figure 23. Load Transient Response
for Discontinuous Mode**

7 Parameter Measurement Information

7.1 Test Circuits

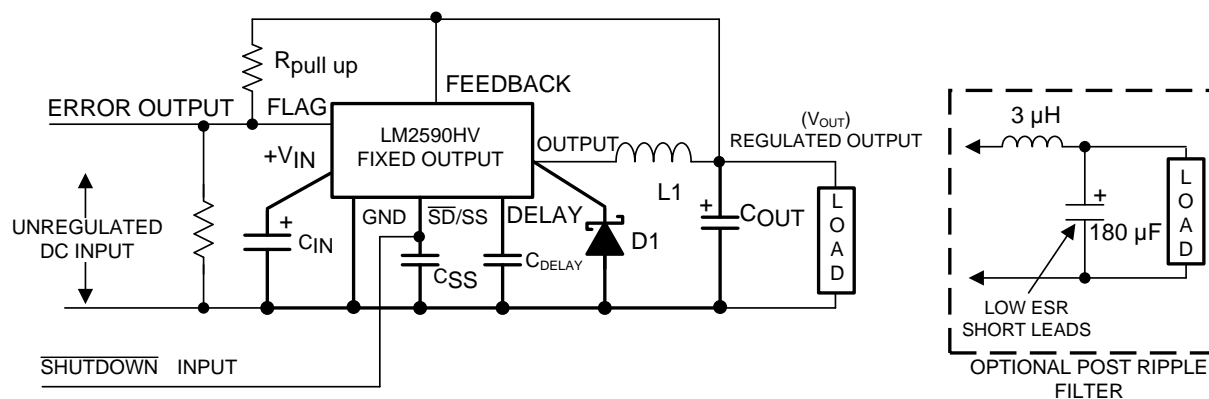

Copyright © 2016, Texas Instruments Incorporated

Component Values shown are for $V_{IN} = 15\text{ V}$,
 $V_{OUT} = 5\text{ V}$, $I_{LOAD} = 1\text{ A}$.
 C_{IN} — 470- μF , 50-V aluminum electrolytic Nichicon *PM Series*
 C_{OUT} — 220- μF , 25-V aluminum electrolytic Nichicon *PM Series*
 $D1$ — 2-A, 60-V Schottky Rectifier, 21DQ06 (international rectifier)
 $L1$ — 68 μH , see [Inductor Selection Procedure](#)

Figure 24. Fixed Output Voltage Versions

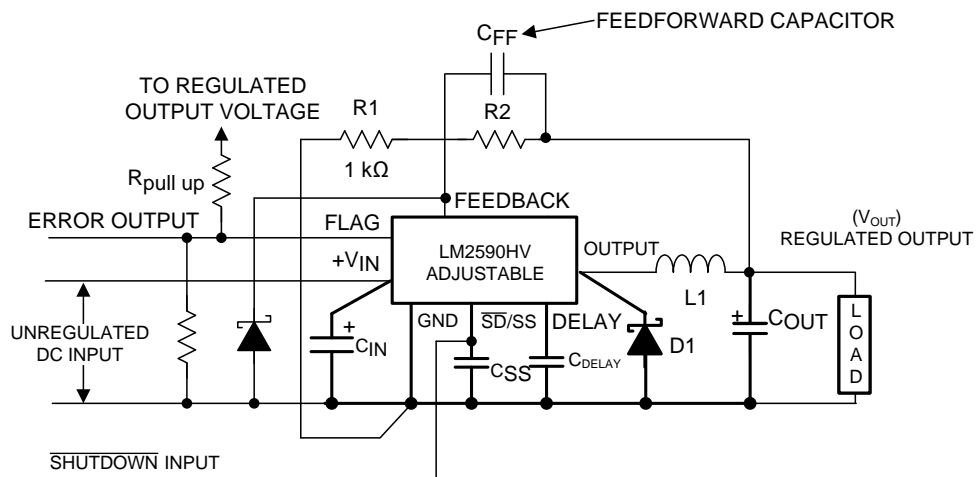
Test Circuits (continued)

Copyright © 2016, Texas Instruments Incorporated

Select R_1 to be approximately 1 k Ω , use a 1% resistor for best stability.

Component values shown are for $V_{IN} = 20$ V,

$V_{OUT} = 10$ V, $I_{LOAD} = 1$ A.

C_{IN} — 470- μ F, 35-V aluminum electrolytic Nichicon *PM Series*

C_{OUT} — 220- μ F, 35-V aluminum electrolytic Nichicon *PM Series*

D1 — 2-A, 60-V Schottky Rectifier, 21DQ06 (international rectifier)

L1 — 100 μ H, see [Inductor Selection Procedure](#)

R_1 — 1 k Ω , 1%

R_2 — 7.15 k, 1%

C_{FF} — 3.3 nF

Typical Values

C_{SS} — 0.1 μ F

C_{DELAY} — 0.1 μ F

$R_{PULL\ UP}$ — 4.7 k (use 22 k if V_{OUT} is ≥ 45 V)

† Resistive divider is required to avoid exceeding maximum rating of 45 V, 3 mA on or into flag pin.

†† Small signal Schottky diode to prevent damage to feedback pin by negative spike when output is shorted.

Required if $V_{IN} > 40$ V

Figure 25. Adjustable Output Voltage Versions

8 Detailed Description

8.1 Overview

The LM2590HV SIMPLE SWITCHER® regulator is an easy to use non-synchronous step-down DC-DC converter with a wide input voltage range up to 60 V. It is capable of delivering up to 1-A DC load current with excellent line and load regulation. These devices are available in fixed output voltages of 3.3-V, 5-V, 12-V and an adjustable output version. The family requires few external components and the pin arrangement was designed for simple, optimum PCB layout.

8.2 Functional Block Diagram

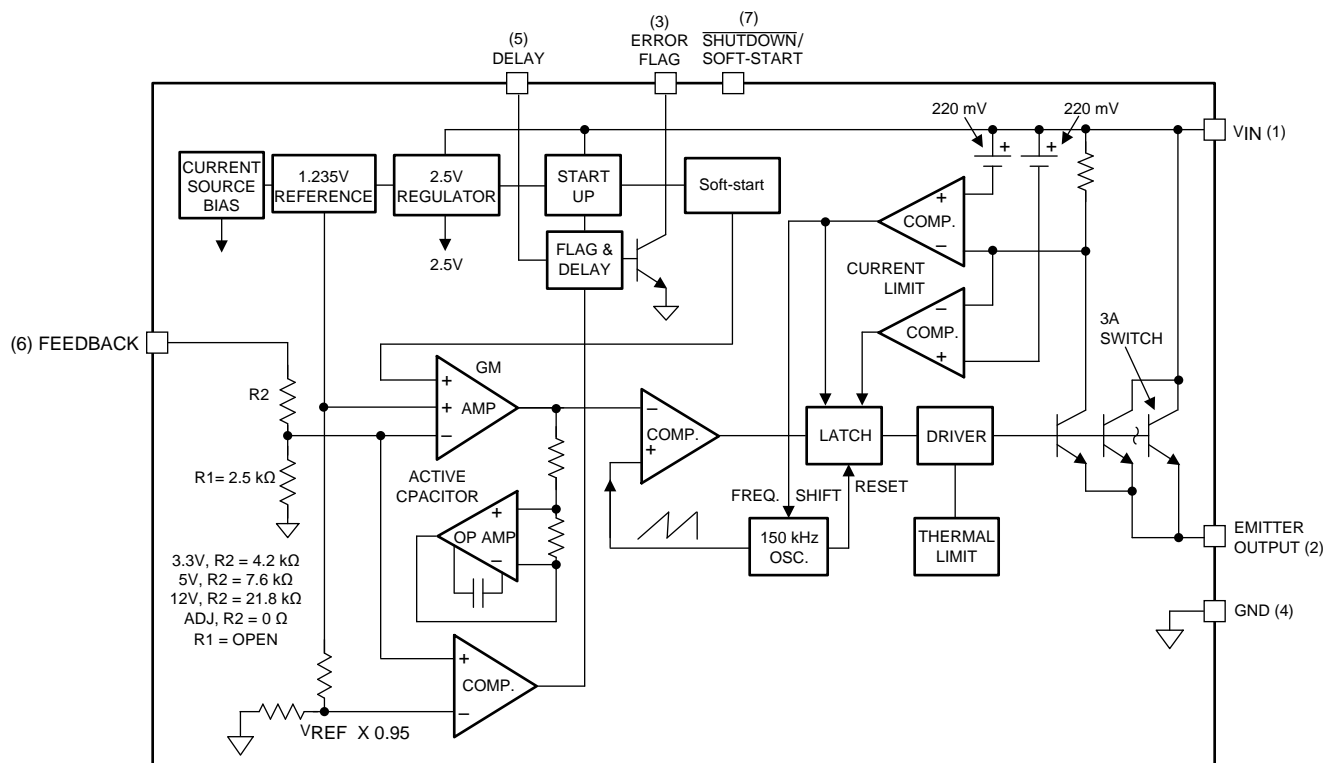

Copyright © 2016, Texas Instruments Incorporated

8.3 Feature Description

8.3.1 Undervoltage Lockout

Some applications require the regulator to remain off until the input voltage reaches a predetermined voltage. [Figure 26](#) contains an undervoltage lockout circuit for a buck configuration, while [Figure 27](#) and [Figure 28](#) are for the inverting types (only the circuitry pertaining to the undervoltage lockout is shown). [Figure 26](#) uses a Zener diode to establish the threshold voltage when the switcher begins operating. When the input voltage is less than the Zener voltage, resistors R1 and R2 hold the SHUTDOWN/SOFT-START pin low, keeping the regulator in the shutdown mode. As the input voltage exceeds the Zener voltage, the Zener conducts, pulling the SHUTDOWN/SOFT-START pin high, allowing the regulator to begin switching. The threshold voltage for the undervoltage lockout feature is approximately 1.5 V greater than the Zener voltage.

Feature Description (continued)

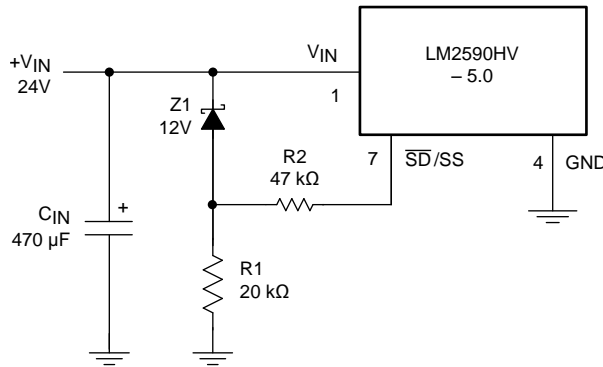

Copyright © 2016, Texas Instruments Incorporated

Figure 26. Undervoltage Lockout for a Buck Regulator

Figure 27 and Figure 28 apply the same feature to an inverting circuit. Figure 27 features a constant threshold voltage for turn on and turn off (Zener voltage plus approximately 1 V). If hysteresis is needed, the circuit in Figure 28 has a turn ON voltage which is different than the turn OFF voltage. The amount of hysteresis is approximately equal to the value of the output voltage. Since the $\overline{SD/SS}$ pin has an internal 7-V Zener clamp, R2 is needed to limit the current into this pin to approximately 1 mA when Q1 is on.

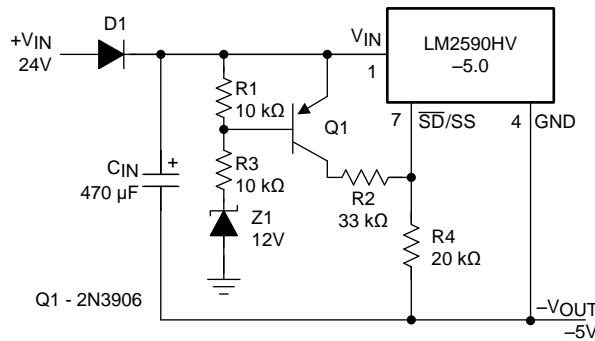

Copyright © 2016, Texas Instruments Incorporated

Figure 27. Undervoltage Lockout Without Hysteresis for an Inverting Regulator

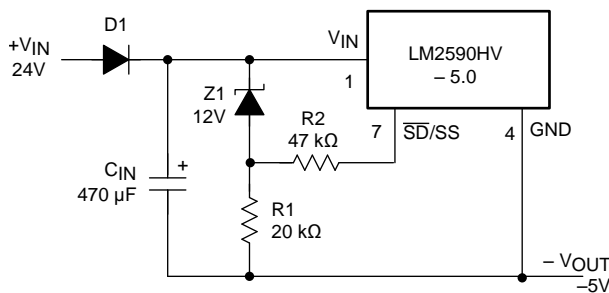

Copyright © 2016, Texas Instruments Incorporated

Figure 28. Undervoltage Lockout With Hysteresis for an Inverting Regulator

Feature Description (continued)

8.3.2 SHUTDOWN/SOFT-START

This reduction in start up current is useful in situations where the input power source is limited in the amount of current it can deliver. In some applications Soft-start can be used to replace undervoltage lockout or delayed startup functions.

If a very slow output voltage ramp is desired, the Soft-start capacitor can be made much larger. Many seconds or even minutes are possible.

If only the shutdown feature is needed, the Soft-start capacitor can be eliminated.

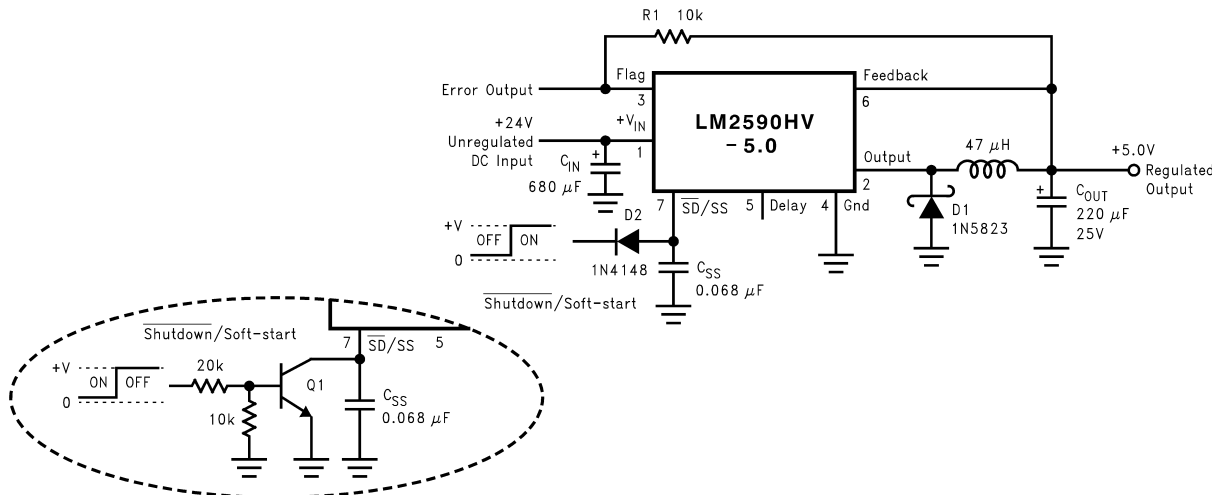

Figure 29. Typical Circuit Using SHUTDOWN/SOFT-START and Error Flag Features

Feature Description (continued)

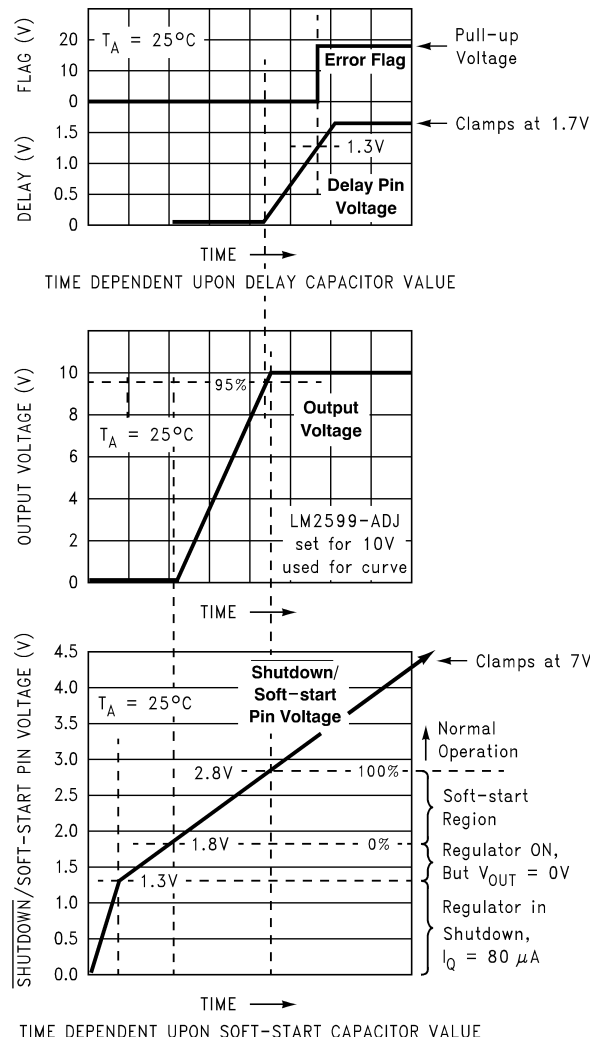

Figure 30. Soft-Start, Delay, Error Output

8.4 Device Functional Modes

8.4.1 Shutdown Mode

The $\overline{\text{SD}}/\text{SS}$ pin provides electrical ON and OFF control for the LM2590HV. When the voltage of this pin is less than 0.6 V, the device is in shutdown mode. The typical standby current in this mode is 90 μA .

8.4.2 Active Mode

When the $\overline{\text{SD}}/\text{SS}$ pin is left floating or pull above 2 V, the device will start switching and the output voltage will rise until it reaches a normal regulation voltage.

9 Application and Implementation

NOTE

Information in the following applications sections is not part of the TI component specification, and TI does not warrant its accuracy or completeness. TI's customers are responsible for determining suitability of components for their purposes. Customers should validate and test their design implementation to confirm system functionality.

9.1 Application Information

9.1.1 Feedforward Capacitor, C_{FF}

(Adjustable output voltage version only)

A feedforward capacitor shown across R2 in [Test Circuits](#) is used when the output voltage is greater than 10 V or when C_{OUT} has a very low ESR. This capacitor adds lead compensation to the feedback loop and increases the phase margin for better loop stability.

If the output voltage ripple is large (>5% of the nominal output voltage), this ripple can be coupled to the feedback pin through the feedforward capacitor and cause the error comparator to trigger the error flag. In this situation, adding a resistor, R_{FF} , in series with the feedforward capacitor, approximately 3 times R1, will attenuate the ripple voltage at the feedback pin.

9.1.2 Input Capacitor, C_{IN}

A low-ESR aluminum or tantalum bypass capacitor is needed between the input pin and ground pin. It must be located near the regulator using short leads. This capacitor prevents large voltage transients from appearing at the input, and provides the instantaneous current needed each time the switch turns on.

The important parameters for the input capacitor are the voltage rating and the RMS current rating. Because of the relatively high RMS currents flowing in the input capacitor of the buck regulator, this capacitor must be chosen for its RMS current rating rather than its capacitance or voltage ratings, although the capacitance value and voltage rating are directly related to the RMS current rating. The voltage rating of the capacitor and its RMS ripple current capability must never be exceeded.

9.1.3 Output Capacitor, C_{OUT}

An output capacitor is required to filter the output and provide regulator loop stability. Low-impedance or low-ESR Electrolytic or solid tantalum capacitors designed for switching regulator applications must be used. When selecting an output capacitor, the important capacitor parameters are; the 100-kHz equivalent series resistance (ESR), the RMS ripple current rating, voltage rating, and capacitance value. For the output capacitor, the ESR value is the most important parameter. The ESR must generally not be less than 100 mΩ or there will be loop instability. If the ESR is too large, efficiency and output voltage ripple are effected. So ESR must be chosen carefully.

9.1.4 Catch Diode

Buck regulators require a diode to provide a return path for the inductor current when the switch turns off. This must be a fast diode and must be located close to the LM2590HV using short leads and short printed circuit traces.

Because of their very fast switching speed and low forward voltage drop, Schottky diodes provide the best performance, especially in low output voltage applications (5 V and lower). Ultra-fast recovery, or high-efficiency rectifiers are also a good choice, but some types with an abrupt turnoff characteristic may cause instability or EMI problems. Ultra-fast recovery diodes typically have reverse recovery times of 50 ns or less. The diode must be chosen for its average or RMS current rating and maximum voltage rating. The voltage rating of the diode must be greater than the DC input voltage (not the output voltage).

Application Information (continued)

9.1.5 Inverting Regulator

The circuit in [Figure 31](#) converts a positive input voltage to a negative output voltage with a common ground. The circuit operates by bootstrapping the regulator's ground pin to the negative output voltage, then grounding the feedback pin, the regulator senses the inverted output voltage and regulates it.

This example uses the LM2590HV 5-V to generate a -5-V output, but other output voltages are possible by selecting other output voltage versions, including the adjustable version. Since this regulator topology can produce an output voltage that is either greater than or less than the input voltage, the maximum output current greatly depends on both the input and output voltage.

To determine how much load current is possible before the internal device current limit is reached (and power limiting occurs), the system must be evaluated as a buck-boost configuration rather than as a buck. The peak switch current in Amperes, for such a configuration is given in [Equation 1](#).

$$I_{PEAK} = I_{LOAD} \times \left(\frac{V_{IN} + V_{OUT}}{V_{IN}} \right) + \frac{V_{IN} \times V_{OUT} \times 10^6}{2 \times L \times f \times (V_{IN} + V_{OUT})}$$

where

- L is in μH
- f is in Hz

(1)

The maximum possible load current, I_{LOAD} , is limited by the requirement that $I_{PEAK} \leq I_{CLIM}$. While checking for this, take I_{CLIM} to be the lowest possible current limit value (minimum across tolerance and temperature is 2.3 A for the LM2590HV). Also to account for inductor tolerances, we must take the minimum value of Inductance for L in the equation above (typically 20% less than the nominal value). Further, the above equation disregards the drop across the Switch and the diode. This is equivalent to assuming 100% efficiency, which is never so. Therefore expect I_{PEAK} to be an additional 10% to 20% higher than calculated from the above equation. Refer to [AN-1197 Selecting Inductors for Buck Converters](#) (SNVA038) for examples based on positive to negative configuration. The maximum voltage appearing across the regulator is the absolute sum of the input and output voltage, and this must be limited to a maximum of 60 V. In this example, when converting 20 V to -5 V, the regulator would see 25 V between the input pin and ground pin. The LM2590HV has a maximum input voltage rating of 60 V. An additional diode is required in this regulator configuration. Diode D1 is used to isolate input voltage ripple or noise from coupling through the C_{IN} capacitor to the output, under light or no load conditions. Also, this diode isolation changes the topology to closely resemble a buck configuration thus providing good closed loop stability. A Schottky diode is recommended for low input voltages, (because of its lower voltage drop) but for higher input voltages, a IN5400 diode could be used. Because of differences in the operation of the inverting regulator, the standard design procedure is not used to select the inductor value. In the majority of designs, a 33- μH , 4-A inductor is the best choice. Capacitor selection can also be narrowed down to just a few values. This type of inverting regulator can require relatively large amounts of input current when starting up, even with light loads. Input currents as high as the LM2590HV current limit (approximately 4 A) are needed for 2 ms or more, until the output reaches its nominal output voltage. The actual time depends on the output voltage and the size of the output capacitor. Input power sources that are current limited or sources that can not deliver these currents without getting loaded down, may not work correctly. Because of the relatively high startup currents required by the inverting topology, the soft-start feature shown in [Figure 31](#) is recommended. Also shown in [Figure 31](#) are several shutdown methods for the inverting configuration. With the inverting configuration, some level shifting is required, because the ground pin of the regulator is no longer at ground, but is now at the negative output voltage. The shutdown methods shown accept ground referenced shutdown signals.

Application Information (continued)

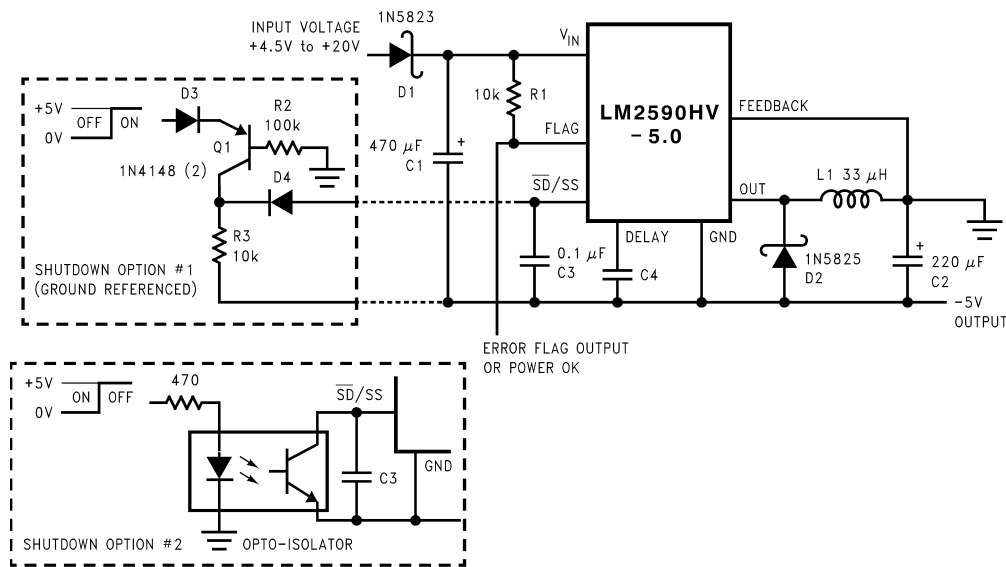
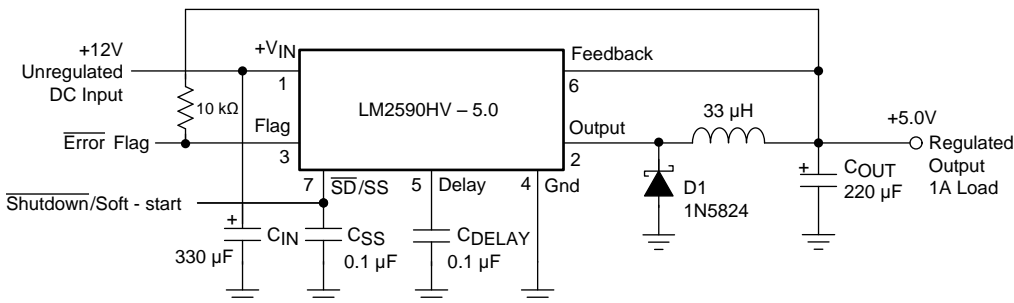

Figure 31. Inverting, -5-V Regulator With Shutdown and Soft-Start

9.2 Typical Application



Copyright © 2016, Texas Instruments Incorporated

Figure 32. LM2590HV 5-V Example Application

9.2.1 Design Requirements

Table 1 lists the example values for this typical application.

Table 1. Design Parameters

PARAMETER	VALUE
Regulated output voltage (3.3 V, 5 V, or adjustable), V_{OUT}	5 V
Maximum input voltage, $V_{IN(max)}$	24 V
Maximum load current, $I_{LOAD(max)}$	1 A
Switching frequency, F	Fixed at a nominal 150 kHz

9.2.2 Detailed Design Procedure

9.2.2.1 Inductor Selection Procedure

For a quick-start, refer to the nomographs provided in [Figure 33](#) to [Figure 35](#). To widen the choices to a more general selection of available inductors, the nomographs provide the required inductance and also the energy in the core expressed in microjoules (μJ), as an alternative to just prescribing custom parts. The following points need to be highlighted:

1. The energy values shown on the nomographs apply to steady operation at the corresponding x-coordinate (rated maximum load current). However under start-up, without soft-start, or a short-circuit on the output, the current in the inductor will momentarily/repetitively hit the current limit I_{CLIM} of the device, and this current could be much higher than the rated load, I_{LOAD} . This represents an overload situation, and can cause the Inductor to saturate (if it has been designed only to handle the energy of steady operation). However most types of core structures used for such applications have a large inherent air gap (for example powdered iron types or ferrite rod inductors), and so the inductance does not fall off too sharply under an overload. The device is usually able to protect itself by not allowing the current to ever exceed I_{CLIM} . But if the DC input voltage to the regulator is over 40 V, the current can slew up so fast under core saturation, that the device may not be able to act fast enough to restrict the current. The current can then rise without limit till destruction of the device takes place. Therefore to ensure reliability, TI recommends that if the DC input voltage exceeds 40 V the inductor must always be sized to handle an instantaneous current equal to I_{CLIM} without saturating, irrespective of the type of core structure or material.

2. Use [Equation 2](#) to calculate the energy under steady operation.

$$e = \frac{1}{2} \times L \times I_{\text{PEAK}}^2 \quad \mu\text{J}$$

where

- L is in μH
 - I_{PEAK} is the peak of the inductor current waveform with the regulator delivering I_{LOAD}
- (2)

These are the energy values shown in the nomographs. See [Example 1](#).

3. The energy under overload is [Equation 3](#).

$$e_{\text{CLIM}} = \frac{1}{2} \times L \times I_{\text{CLIM}}^2 \quad \mu\text{J}$$
(3)

If $V_{\text{IN}} > 40 \text{ V}$, the inductor must be sized to handle e_{CLIM} instead of the steady energy values. The worst case I_{CLIM} for the LM2590HV is 3 A. The energy rating depends on the inductance. See [Example 2](#).

4. The nomographs were generated by allowing a greater amount of percentage current ripple in the Inductor as the maximum rated load decreases (see [Figure 36](#)). This was done to permit the use of smaller inductors at light loads. However, [Figure 36](#) shows only the *median* value of the current ripple. In reality there may be a great spread around this because the nomographs approximate the exact calculated inductance to standard available values. Refer to [AN-1197 Selecting Inductors for Buck Converters](#) (SNVA038) for detailed calculations if a certain maximum inductor current ripple is required for various possible reasons. Also consider the rather wide tolerance on the nominal inductance of commercial inductors.
5. [Figure 35](#) shows the inductor selection curves for the Adjustable version. The y-axis is Et , in $V\mu\text{secs}$. It is the applied volts across the inductor during the ON time of the switch ($V_{\text{IN}} - V_{\text{SAT}} - V_{\text{OUT}}$) multiplied by the time for which the switch is on in μsecs . See [Example 3](#).

9.2.2.1.1 Example 1: $V_{\text{IN}} \leq 40 \text{ V}$, 5-V Version, $V_{\text{IN}} = 24 \text{ V}$, Output = 5 V at 1 A

1. A first pass inductor selection is based upon Inductance and rated max load current. We choose an inductor with the Inductance value indicated by the nomograph (see [Figure 34](#)) and a current rating equal to the maximum load current. We therefore quick-select a 68- μH , 1-A inductor (designed for 150 kHz operation) for this application
2. We must confirm that it is rated to handle 50 μJ (see [Figure 34](#)) by either estimating the peak current or by a detailed calculation as shown in [AN-1197 Selecting Inductors for Buck Converters](#) (SNVA038), and also that the losses are acceptable.

9.2.2.1.2 Example 2: $V_{\text{IN}} > 40 \text{ V}$, 5-V Version, $V_{\text{IN}} = 48 \text{ V}$, Output = 5 V at 1.5 A

1. A first pass inductor selection is based upon Inductance and the switch current limit. We choose an inductor

with the Inductance value indicated by the nomograph (see [Figure 34](#)) and a current rating equal to I_{CLIM} . We therefore quick-select a 68- μ H, 4-A inductor (designed for 150 kHz operation) for this application.

- We must confirm that it is rated to handle e_{CLIM} by the procedure shown in [AN-1197 Selecting Inductors for Buck Converters](#) (SNVA038) and that the losses are acceptable. Here e_{CLIM} is [Equation 4](#).

$$e_{CLIM} = \frac{1}{2} \times 100 \times 3^2 = 450 \mu\text{J} \quad (4)$$

9.2.2.1.3 Example 3: $V_{IN} \leq 40$ V, Adjustable Version, $V_{IN} = 20$ V, Output = 10 V at 2 A

- Since input voltage is less than 40 V, a first pass inductor selection is based upon Inductance and rated max load current. We choose an inductor with the Inductance value indicated by the nomograph [Figure 35](#) and a current rating equal to the maximum load. But we first need to calculate Et for the given application. The Duty cycle is [Equation 5](#).

$$D = \frac{V_{OUT} + V_D}{V_{IN} - V_{SAT} + V_D}$$

where

- V_D is the drop across the catch diode (0.5 V for a Schottky)
- V_{SAT} the drop across the switch (1.5 V)

So this yields [Equation 6](#).

$$D = \frac{10 + 0.5}{20 - 1.5 + 0.5} = 0.55 \quad (6)$$

- The switch ON time is calculated with [Equation 7](#).

$$t_{ON} = \frac{D}{f} \times 10^6 \mu\text{s}$$

where

- f is the switching frequency in Hz

So this yields [Equation 8](#).

$$\begin{aligned} Et &= (V_{IN} - V_{SAT} - V_{OUT}) \times t_{ON} \\ &= (20 - 1.5 - 10) \times \frac{0.55}{150000} \times 10^6 \text{ V}\mu\text{secs} \\ &= 31.3 \text{ V}\mu\text{secs} \end{aligned} \quad (8)$$

- Therefore, looking at [Figure 33](#), quick-select a 47- μ H, 2-A inductor (designed for 150 kHz operation) for this application.
- Confirm that it is rated to handle 200 μ J (see [Figure 35](#)) by the procedure shown in [AN-1197 Selecting Inductors for Buck Converters](#) (SNVA038) and that the losses are acceptable. (If the DC Input voltage had been greater than 40 V we would need to consider e_{CLIM} as in [Example 2](#)). This completes the simplified inductor selection procedure. For more general applications and better optimization, refer to [AN-1197 Selecting Inductors for Buck Converters](#) (SNVA038).

LM2590HV

JAJS710C – DECEMBER 2001 – REVISED JULY 2016

www.ti.com

9.2.3 Application Curves

For continuous mode operation

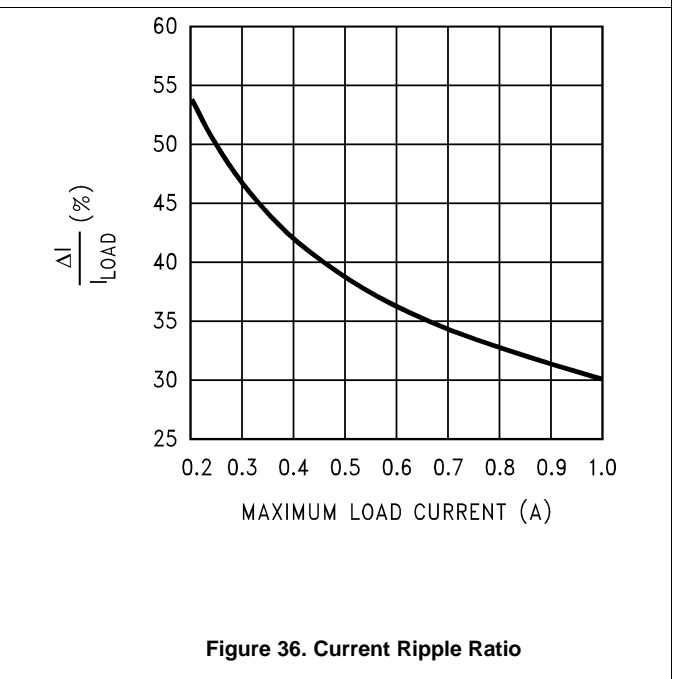
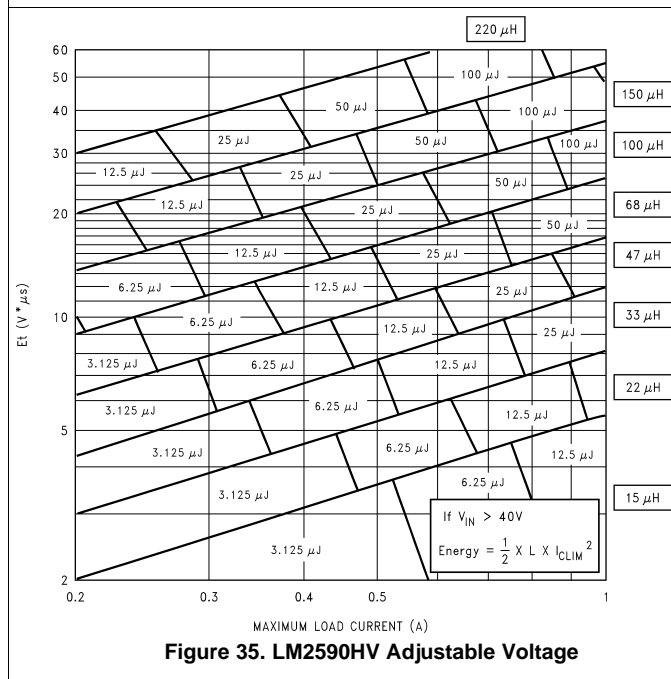
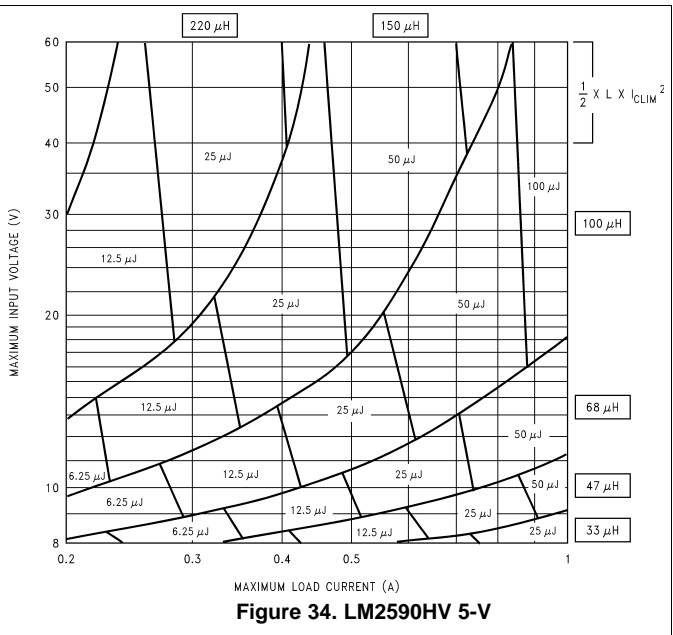
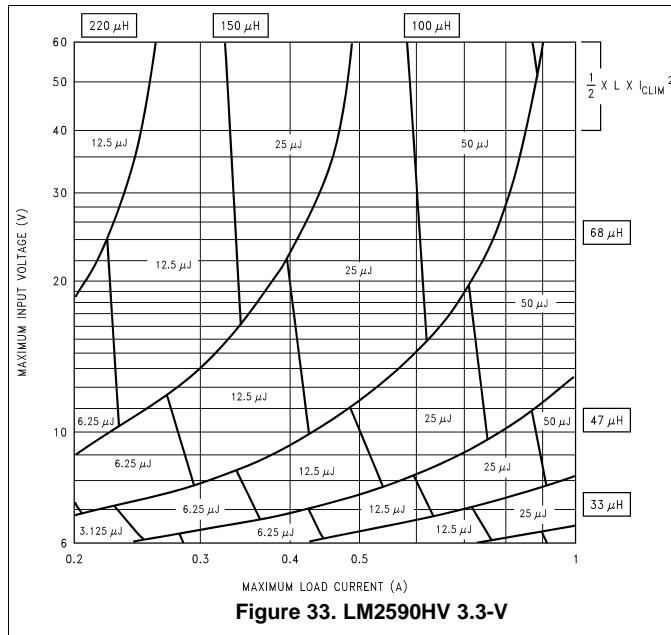

10 Power Supply Recommendations

The LM2590HV is designed to operate from an input voltage supply up to 60 V. This input supply must be well regulated and able to withstand maximum input current and maintain a stable voltage.

11 Layout

11.1 Layout Guidelines

As in any switching regulator, layout is very important. Rapidly switching currents associated with wiring inductance can generate voltage transients which can cause problems. For minimal inductance and ground loops, with reference to [Test Circuits](#), the wires indicated by heavy lines must be wide printed circuit traces and must be kept as short as possible. For best results, external components must be located as close to the switcher IC as possible using ground plane construction or single point grounding.

If open-core inductors are used, special care must be taken as to the location and positioning of this type of inductor. Allowing the inductor flux to intersect sensitive feedback, IC groundpath and C_{OUT} wiring can cause problems.

When using the adjustable version, take special care as to the location of the feedback resistors and the associated wiring. Physically locate both resistors near the IC, and route the wiring away from the inductor, especially an open-core type of inductor.

11.2 Layout Examples

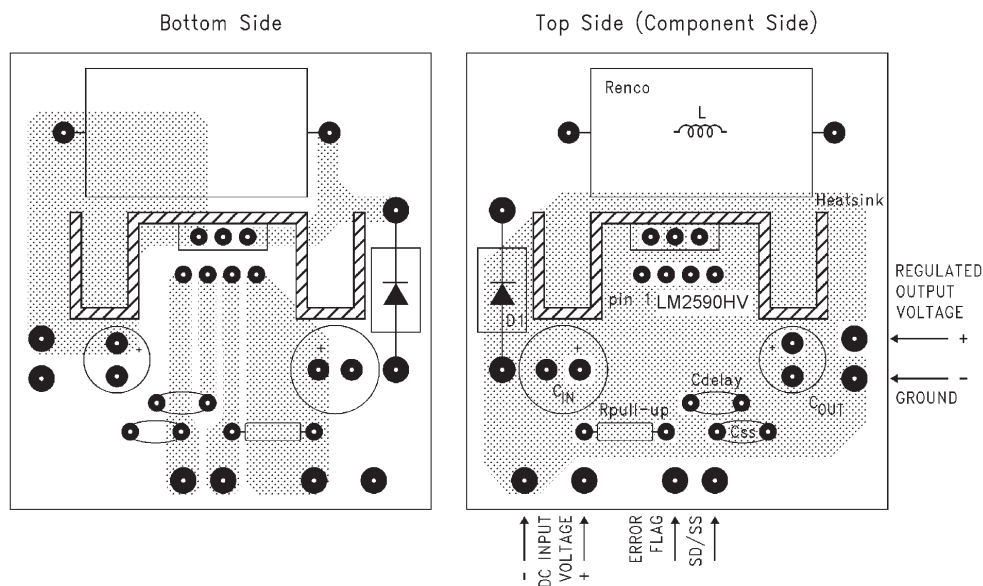

C_{IN} = 470- μ F, 50-V aluminum electrolytic Panasonic *HFQ Series*
 C_{OUT} = 330- μ F, 35-V aluminum electrolytic Panasonic *HFQ Series*
 $D1$ = 5-A, 40-V Schottky rectifier, 1N5825
 $L1$ = 47- μ H, L39 Renco through-hole
 $R_{PULL\ UP}$ = 10k
 C_{DELAY} = 0.1 μ F
 $C_{SD/SS}$ = 0.1 μ F
 Thermalloy heat sink #7020

Figure 37. Typical Through-Hole PCB Layout, Fixed Output (1x Size), Double-Sided

Layout Examples (continued)

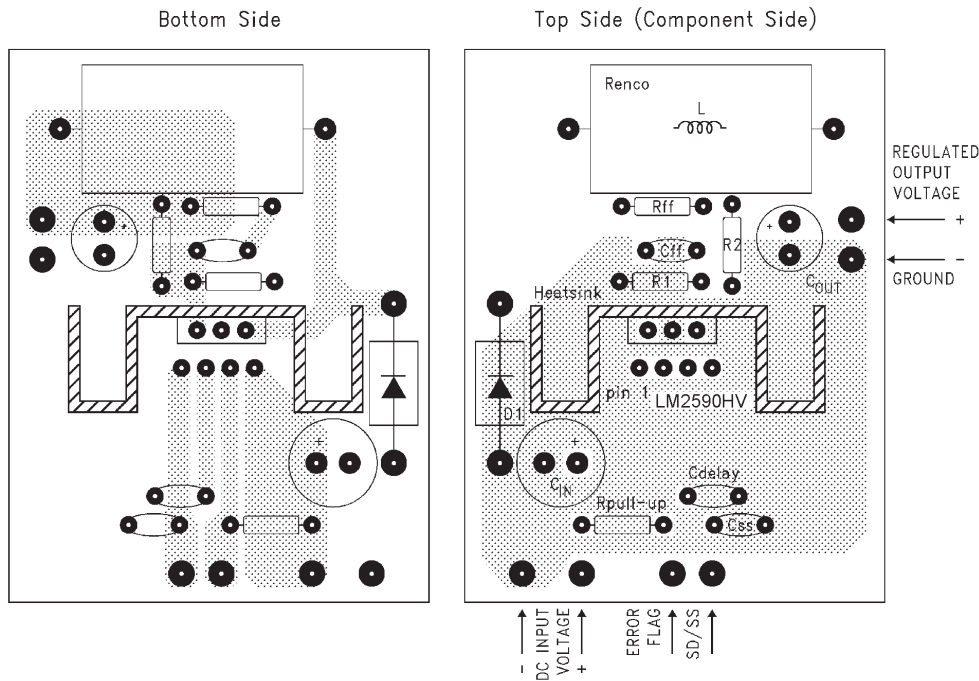

- C_{IN} = 470- μ F, 50-V aluminum electrolytic Panasonic *HFQ Series*
- C_{OUT} = 220- μ F, 35-V aluminum electrolytic Panasonic *HFQ Series*
- D1 = 5-A, 40-V Schottky Rectifier, 1N5825
- L1 = 47- μ H, L39 Renco, through-hole
- R_1 = 1 k Ω , 1%
- R_2 = Use formula in [Detailed Design Procedure](#)
- C_{FF} = See [Feedforward Capacitor, \$C_{FF}\$](#)
- R_{FF} = See [Feedforward Capacitor, \$C_{FF}\$](#)
- $R_{PULL\ UP}$ = 10k
- C_{DELAY} = 0.1 μ F
- $C_{SD/SS}$ = 0.1 μ F
- Thermalloy heat sink #7020

Figure 38. Typical Through-Hole PCB Layout, Adjustable Output (1x Size), Double-Sided

11.3 Thermal Considerations

The LM2590HV is available in two packages, a 5-pin TO-220 (T) and a 5-pin surface-mount TO-263 (S). The TO-220 package needs a heat sink under most conditions. The size of the heatsink depends on the input voltage, the output voltage, the load current and the ambient temperature. Higher ambient temperatures require more heat sinking. The TO-263 surface-mount package tab is designed to be soldered to the copper on a printed circuit board. The copper and the board are the heat sink for this package and the other heat producing components, such as the catch diode and inductor. The PCB copper area that the package is soldered to must be at least 0.4 in², and ideally must have 2 or more square inches of 2 oz. (0.0028) in. copper. Additional copper area improves the thermal characteristics, but with copper areas greater than approximately 6 in², only small improvements in heat dissipation are realized. If further thermal improvements are needed, double-sided, multilayer PC board with large copper areas or airflow are recommended. The curves shown in [Figure 39](#) show the LM2590HV (TO-263 package) junction temperature rise above ambient temperature with a 2-A load for various input and output voltages. This data was taken with the circuit operating as a buck switching regulator with all components mounted on a PCB to simulate the junction temperature under actual operating conditions. This curve can be used for a quick check for the approximate junction temperature for various conditions, but be aware that there are many factors that can affect the junction temperature. When load currents higher than 2 A

Thermal Considerations (continued)

are used, double-sided or multilayer boards with large copper areas or airflow might be needed, especially for high ambient temperatures and high output voltages. For the best thermal performance, wide copper traces and generous amounts of printed circuit board copper must be used in the board layout. One exception to this is the output (switch) pin, which must not have large areas of copper. Large areas of copper provide the best transfer of heat (lower thermal resistance) to the surrounding air, and moving air lowers the thermal resistance even further. Package thermal resistance and junction temperature rise numbers are all approximate, and there are many factors that will affect these numbers. Some of these factors include board size, shape, thickness, position, location, and even board temperature. Other factors are, trace width, total printed circuit copper area, copper thickness, single- or double-sided, multilayer board and the amount of solder on the board. The effectiveness of the PCB to dissipate heat also depends on the size, quantity and spacing of other components on the board, as well as whether the surrounding air is still or moving. Furthermore, some of these components such as the catch diode will add heat to the PCB and the heat can vary as the input voltage changes. For the inductor, depending on the physical size, type of core material and the DC resistance, it could either act as a heat sink taking heat away from the board, or it could add heat to the board.

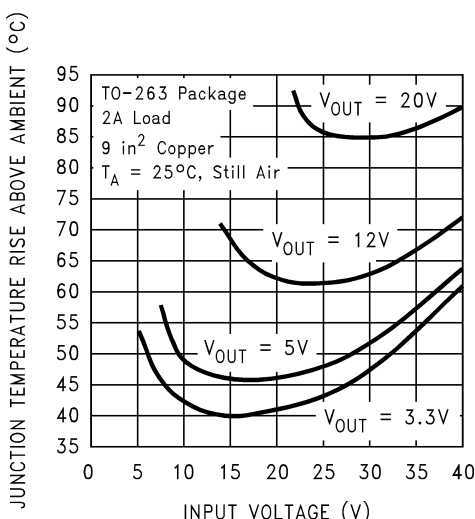

Figure 39. Junction Temperature Rise, TO-263

12 デバイスおよびドキュメントのサポート

12.1 ドキュメントのサポート

12.1.1 関連資料

関連資料については、以下を参照してください。

『[AN-1197 バック・コンバータ用のインダクタの選択](#)』(SNVA038)

12.2 ドキュメントの更新通知を受け取る方法

ドキュメントの更新についての通知を受け取るには、ti.comのデバイス製品フォルダを開いてください。右上の隅にある「通知を受け取る」をクリックして登録すると、変更されたすべての製品情報に関するダイジェストを毎週受け取れます。変更の詳細については、修正されたドキュメントに含まれている改訂履歴をご覧ください。

12.3 コミュニティ・リソース

The following links connect to TI community resources. Linked contents are provided "AS IS" by the respective contributors. They do not constitute TI specifications and do not necessarily reflect TI's views; see TI's [Terms of Use](#).

TI E2E™ Online Community *TI's Engineer-to-Engineer (E2E) Community*. Created to foster collaboration among engineers. At e2e.ti.com, you can ask questions, share knowledge, explore ideas and help solve problems with fellow engineers.

Design Support *TI's Design Support* Quickly find helpful E2E forums along with design support tools and contact information for technical support.

12.4 商標

E2E is a trademark of Texas Instruments.

All other trademarks are the property of their respective owners.

12.5 静電気放電に関する注意事項



これらのデバイスは、限定的なESD(静電破壊)保護機能を内蔵しています。保存時または取り扱い時は、MOSゲートに対する静電破壊を防止するために、リード線同士をショートさせておくか、デバイスを導電フォームに入れる必要があります。

12.6 Glossary

[SLYZ022](#) — *TI Glossary*.

This glossary lists and explains terms, acronyms, and definitions.

13 メカニカル、パッケージ、および注文情報

以降のページには、メカニカル、パッケージ、および注文に関する情報が記載されています。これらの情報は、指定のデバイスに対して提供されている最新のデータです。このデータは予告なく変更されることがあり、ドキュメントが改訂される場合もあります。本データシートのブラウザ版を使用されている場合は、画面左側の説明をご覧ください。

PACKAGING INFORMATION

Orderable part number	Status (1)	Material type (2)	Package Pins	Package qty Carrier	RoHS (3)	Lead finish/ Ball material (4)	MSL rating/ Peak reflow (5)	Op temp (°C)	Part marking (6)
LM2590HVS-3.3/NOPB	Active	Production	DDPAK/TO-263 (KTW) 7	45 TUBE	ROHS Exempt	SN	Level-3-245C-168 HR	-40 to 125	LM2590HVS -3.3 P+
LM2590HVS-3.3/NOPB.B	Active	Production	DDPAK/TO-263 (KTW) 7	45 TUBE	ROHS Exempt	SN	Level-3-245C-168 HR	-40 to 125	LM2590HVS -3.3 P+
LM2590HVS-5.0/NOPB	Active	Production	DDPAK/TO-263 (KTW) 7	45 TUBE	ROHS Exempt	SN	Level-3-245C-168 HR	-40 to 125	LM2590HVS -5.0 P+
LM2590HVS-5.0/NOPB.B	Active	Production	DDPAK/TO-263 (KTW) 7	45 TUBE	ROHS Exempt	SN	Level-3-245C-168 HR	-40 to 125	LM2590HVS -5.0 P+
LM2590HVS-ADJ/NOPB	Active	Production	DDPAK/TO-263 (KTW) 7	45 TUBE	ROHS Exempt	SN	Level-3-245C-168 HR	-40 to 125	LM2590HVS -ADJ P+
LM2590HVS-ADJ/NOPB.B	Active	Production	DDPAK/TO-263 (KTW) 7	45 TUBE	ROHS Exempt	SN	Level-3-245C-168 HR	-40 to 125	LM2590HVS -ADJ P+
LM2590HVSX-3.3/NOPB	Active	Production	DDPAK/TO-263 (KTW) 7	500 LARGE T&R	ROHS Exempt	SN	Level-3-245C-168 HR	-40 to 125	LM2590HVS -3.3 P+
LM2590HVSX-5.0/NOPB	Active	Production	DDPAK/TO-263 (KTW) 7	500 LARGE T&R	ROHS Exempt	SN	Level-3-245C-168 HR	-40 to 125	LM2590HVS -5.0 P+
LM2590HVSX-ADJ/NOPB	Active	Production	DDPAK/TO-263 (KTW) 7	500 LARGE T&R	ROHS Exempt	SN	Level-3-245C-168 HR	-40 to 125	LM2590HVS -ADJ P+
LM2590HVT-5.0/NOPB	Active	Production	TO-220 (NDZ) 7	45 TUBE	Yes	SN	Level-1-NA-UNLIM	-40 to 125	LM2590HVT -5.0 P+
LM2590HVT-5.0/NOPB.B	Active	Production	TO-220 (NDZ) 7	45 TUBE	Yes	SN	Level-1-NA-UNLIM	-40 to 125	LM2590HVT -5.0 P+
LM2590HVT-ADJ/NOPB	Active	Production	TO-220 (NDZ) 7	45 TUBE	Yes	SN	Level-1-NA-UNLIM	-40 to 125	LM2590HVT -ADJ P+
LM2590HVT-ADJ/NOPB.B	Active	Production	TO-220 (NDZ) 7	45 TUBE	Yes	SN	Level-1-NA-UNLIM	-40 to 125	LM2590HVT -ADJ P+

(1) **Status:** For more details on status, see our [product life cycle](#).

(2) **Material type:** When designated, preproduction parts are prototypes/experimental devices, and are not yet approved or released for full production. Testing and final process, including without limitation quality assurance, reliability performance testing, and/or process qualification, may not yet be complete, and this item is subject to further changes or possible discontinuation. If available for ordering, purchases will be subject to an additional waiver at checkout, and are intended for early internal evaluation purposes only. These items are sold without warranties of any kind.

(3) **RoHS values:** Yes, No, RoHS Exempt. See the [TI RoHS Statement](#) for additional information and value definition.

(4) **Lead finish/Ball material:** Parts may have multiple material finish options. Finish options are separated by a vertical ruled line. Lead finish/Ball material values may wrap to two lines if the finish value exceeds the maximum column width.

(5) **MSL rating/Peak reflow:** The moisture sensitivity level ratings and peak solder (reflow) temperatures. In the event that a part has multiple moisture sensitivity ratings, only the lowest level per JEDEC standards is shown. Refer to the shipping label for the actual reflow temperature that will be used to mount the part to the printed circuit board.

(6) **Part marking:** There may be an additional marking, which relates to the logo, the lot trace code information, or the environmental category of the part.

Multiple part markings will be inside parentheses. Only one part marking contained in parentheses and separated by a "~" will appear on a part. If a line is indented then it is a continuation of the previous line and the two combined represent the entire part marking for that device.

Important Information and Disclaimer: The information provided on this page represents TI's knowledge and belief as of the date that it is provided. TI bases its knowledge and belief on information provided by third parties, and makes no representation or warranty as to the accuracy of such information. Efforts are underway to better integrate information from third parties. TI has taken and continues to take reasonable steps to provide representative and accurate information but may not have conducted destructive testing or chemical analysis on incoming materials and chemicals. TI and TI suppliers consider certain information to be proprietary, and thus CAS numbers and other limited information may not be available for release.

In no event shall TI's liability arising out of such information exceed the total purchase price of the TI part(s) at issue in this document sold by TI to Customer on an annual basis.

TAPE AND REEL INFORMATION

QUADRANT ASSIGNMENTS FOR PIN 1 ORIENTATION IN TAPE



*All dimensions are nominal

Device	Package Type	Package Drawing	Pins	SPQ	Reel Diameter (mm)	Reel Width W1 (mm)	A0 (mm)	B0 (mm)	K0 (mm)	P1 (mm)	W (mm)	Pin1 Quadrant
LM2590HVSX-3.3/NOPB	DDPAK/TO-263	KTW	7	500	330.0	24.4	10.75	14.85	5.0	16.0	24.0	Q2
LM2590HVSX-5.0/NOPB	DDPAK/TO-263	KTW	7	500	330.0	24.4	10.75	14.85	5.0	16.0	24.0	Q2
LM2590HVSX-ADJ/NOPB	DDPAK/TO-263	KTW	7	500	330.0	24.4	10.75	14.85	5.0	16.0	24.0	Q2

TAPE AND REEL BOX DIMENSIONS

*All dimensions are nominal

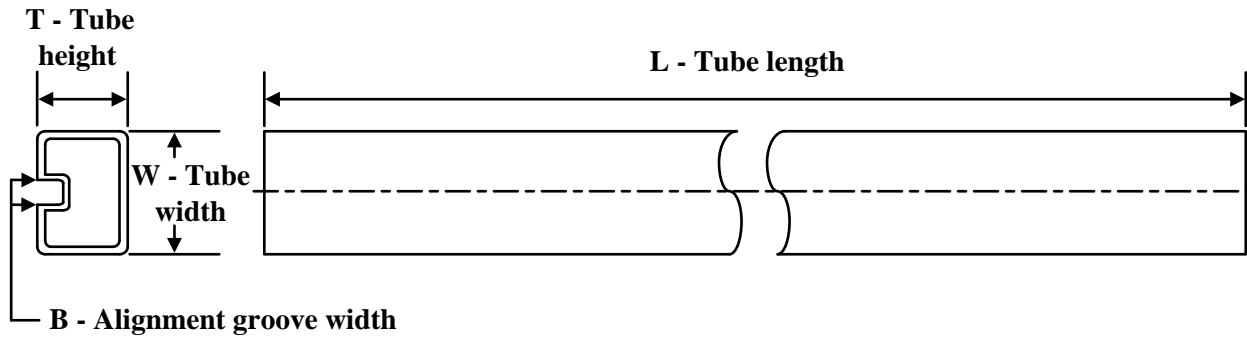
Device	Package Type	Package Drawing	Pins	SPQ	Length (mm)	Width (mm)	Height (mm)
LM2590HVSX-3.3/NOPB	DDPAK/TO-263	KTW	7	500	356.0	356.0	45.0
LM2590HVSX-5.0/NOPB	DDPAK/TO-263	KTW	7	500	356.0	356.0	45.0
LM2590HVSX-ADJ/NOPB	DDPAK/TO-263	KTW	7	500	356.0	356.0	45.0

TUBE

*All dimensions are nominal

Device	Package Name	Package Type	Pins	SPQ	L (mm)	W (mm)	T (μm)	B (mm)
LM2590HVS-3.3/NOPB	KTW	TO-263	7	45	502	25	8204.2	9.19
LM2590HVS-3.3/NOPB.B	KTW	TO-263	7	45	502	25	8204.2	9.19
LM2590HVS-5.0/NOPB	KTW	TO-263	7	45	502	25	8204.2	9.19
LM2590HVS-5.0/NOPB.B	KTW	TO-263	7	45	502	25	8204.2	9.19
LM2590HVS-ADJ/NOPB	KTW	TO-263	7	45	502	25	8204.2	9.19
LM2590HVS-ADJ/NOPB.B	KTW	TO-263	7	45	502	25	8204.2	9.19
LM2590HVT-5.0/NOPB	NDZ	TO-220	7	45	502	30	30048.2	10.74
LM2590HVT-5.0/NOPB.B	NDZ	TO-220	7	45	502	30	30048.2	10.74
LM2590HVT-ADJ/NOPB	NDZ	TO-220	7	45	502	30	30048.2	10.74
LM2590HVT-ADJ/NOPB.B	NDZ	TO-220	7	45	502	30	30048.2	10.74

NDZ0007B

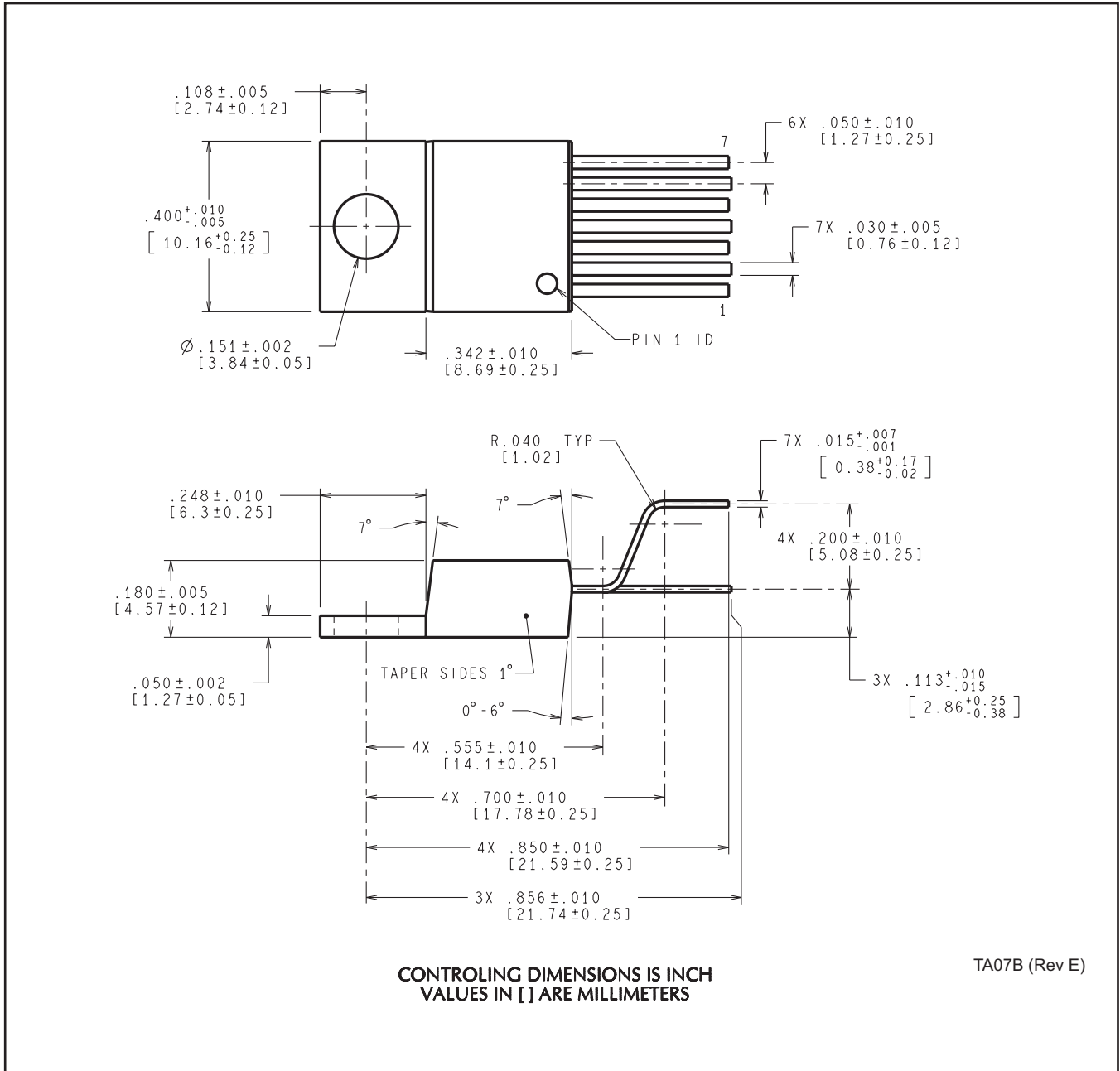

KTW0007B

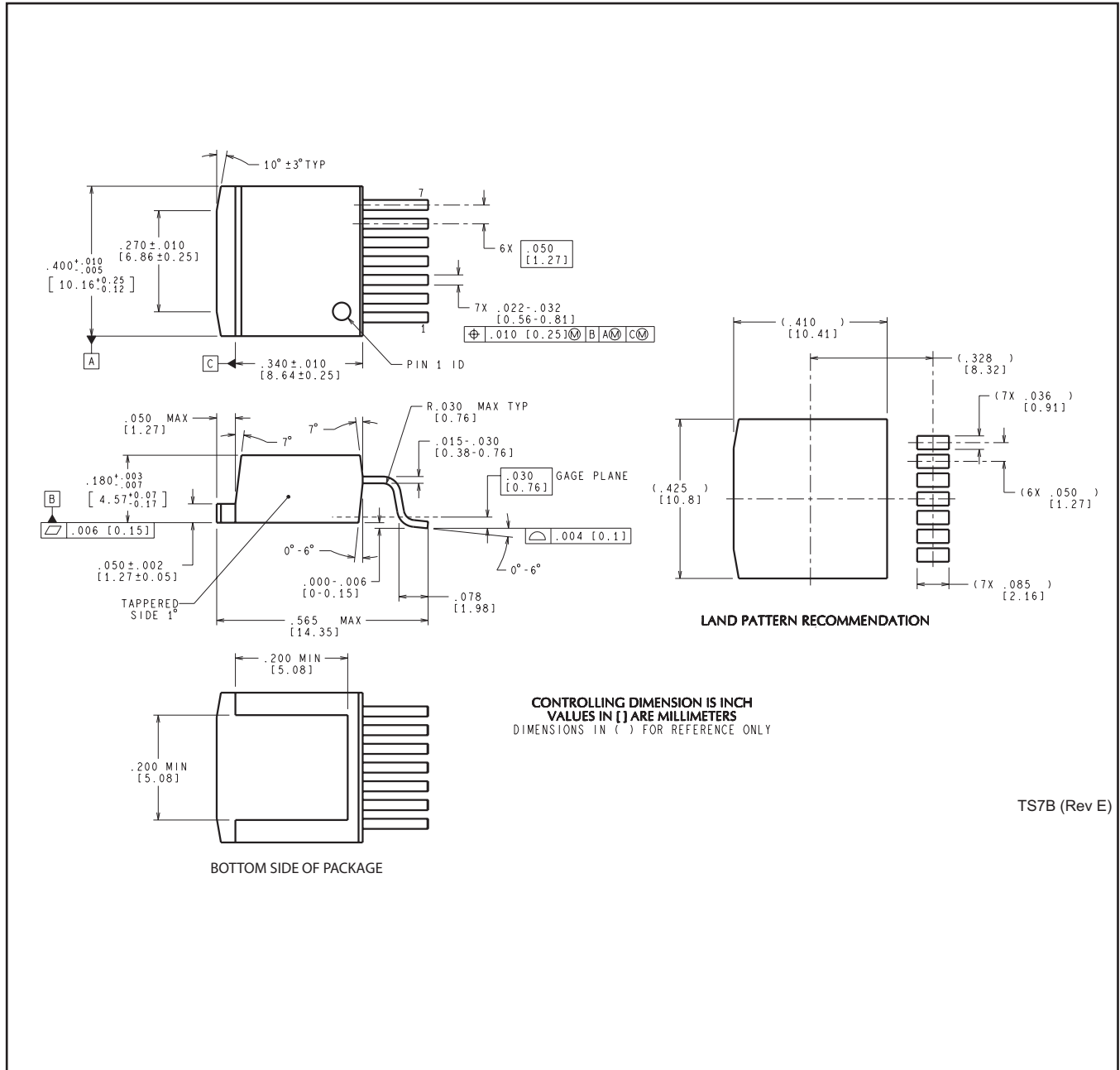

TS7B (Rev E)

重要なお知らせと免責事項

TI は、技術データと信頼性データ (データシートを含みます)、設計リソース (リファレンス デザインを含みます)、アプリケーションや設計に関する各種アドバイス、Web ツール、安全性情報、その他のリソースを、欠陥が存在する可能性のある「現状のまま」提供しており、商品性および特定目的に対する適合性の黙示保証、第三者の知的財産権の非侵害保証を含むいかなる保証も、明示的または黙示的にかかわらず拒否します。

これらのリソースは、TI 製品を使用する設計の経験を積んだ開発者への提供を意図したものです。(1) お客様のアプリケーションに適した TI 製品の選定、(2) お客様のアプリケーションの設計、検証、試験、(3) お客様のアプリケーションに該当する各種規格や、その他のあらゆる安全性、セキュリティ、規制、または他の要件への確実な適合に関する責任を、お客様のみが単独で負うものとし、

上記の各種リソースは、予告なく変更される可能性があります。これらのリソースは、リソースで説明されている TI 製品を使用するアプリケーションの開発の目的でのみ、TI はその使用をお客様に許諾します。これらのリソースに関して、他の目的で複製することや掲載することは禁止されています。TI や第三者の知的財産権のライセンスが付与されている訳ではありません。お客様は、これらのリソースを自身で使用した結果発生するあらゆる申し立て、損害、費用、損失、責任について、TI およびその代理人を完全に補償するものとし、TI は一切の責任を拒否します。

TI の製品は、[TI の販売条件](#)、[TI の総合的な品質ガイドライン](#)、[ti.com](#) または TI 製品などに関連して提供される他の適用条件に従い提供されます。TI がこれらのリソースを提供することは、適用される TI の保証または他の保証の放棄の拡大や変更を意味するものではありません。TI がカスタム、またはカスタマー仕様として明示的に指定していない限り、TI の製品は標準的なカタログに掲載される汎用機器です。

お客様がいかなる追加条項または代替条項を提案する場合も、TI はそれらに異議を唱え、拒否します。

Copyright © 2026, Texas Instruments Incorporated

最終更新日 : 2025 年 10 月