

LMK1D1204P ピン制御 OE、低付加ジッタ LVDS バッファ

1 特長

- 2 入力、4 出力 (2:4) 高性能 LVDS クロック・バッファ・ファミリ
- 出力周波数: 最大 2GHz
- 個別の出力イネーブル / ディセーブル用ハードウェア・ピン
- 電源電圧: 1.8V / 2.5V / 3.3V ±5%
- 小さい付加ジッタ: 156.25MHz 時、12kHz~20MHz の範囲で最大 60fs rms
 - 非常に小さい位相ノイズ・フロア: -164dBc/Hz (標準値)
- 非常に小さい伝搬遅延: 575ps (最大値)
- 出力スキュー: 20ps (最大値)
- フェイルセーフ入力
- ユニバーサル入力は LVDS、LVPECL、LVCMOS、HCSL、CML の信号レベルに対応
- LVDS リファレンス電圧 V_{AC_REF} は、容量性結合入力に使用可能
- 産業用温度範囲: -40°C~105°C
- パッケージ:
 - 5mm × 5mm、28 ピン VQFN (RHD)

2 アプリケーション

- テレコミュニケーションおよびネットワーク機器
- 医療用画像処理
- 試験 / 測定機器
- ワイヤレス・インフラ
- 業務用オーディオ、ビデオ、サイネージ

3 概要

LMK1D1204P クロック・バッファは、2 つのクロック入力 (IN0 および IN1) のいずれか 1 つを 4 ペアの差動 LVDS クロック出力 (OUT0~OUT3) に分配します。このとき、クロック分配のスキューを最小限に抑えます。入力は LVDS、LVPECL、LVCMOS、HCSL、CML のいずれかに対応可能です。

LMK1D1204P は、50Ω 伝送経路の駆動に特化して設計されています。シングルエンド・モードで入力を駆動する場合は、未使用の負入力ピンに適切なバイアス電圧を印加する必要があります (図 9-6 参照)。IN_SEL ピンは、どの入力を出力に転送するかを選択します。このデバイスは、フェイルセーフ入力機能をサポートしています。さらに、このデバイスは入力ヒステリシスを備えており、入力信号が存在しないときに出力がランダムに発振することを防止します。

各 LVDS 差動出力は、対応する OEx ピンをロジック HIGH 「1」に設定するとイネーブルになります。このピンがロジック LOW 「0」に設定されている場合、出力がディセーブルされて HIGH Z 状態になり、消費電力の低減につながります。

このデバイスは、1.8V、2.5V または 3.3V 電源で動作し、-40°C~105°C (周囲温度) で動作が規定されています。

パッケージ情報

部品番号	パッケージ(1)	パッケージ・サイズ (公称) (2)
LMK1D1204P	VQFN (28)	5.00mm × 5.00mm

- 利用可能なすべてのパッケージについては、データシートの末尾にある注文情報を参照してください。
- パッケージ・サイズ (長さ × 幅) は公称値であり、該当する場合はピンも含まれます。

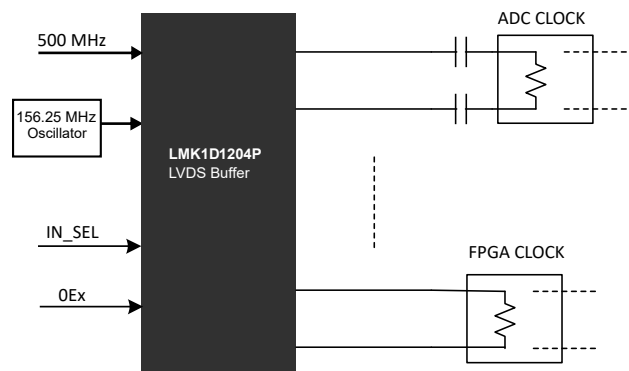

アプリケーションの例



Table of Contents

1 特長	1	9.2 Functional Block Diagram.....	13
2 アプリケーション	1	9.3 Feature Description.....	14
3 概要	1	9.4 Device Functional Modes.....	14
4 Revision History	2	10 Application and Implementation	17
5 Device Comparison	3	10.1 Application Information.....	17
6 Pin Configuration and Functions	4	10.2 Typical Application.....	17
7 Specifications	6	10.3 Power Supply Recommendations.....	20
7.1 Absolute Maximum Ratings.....	6	10.4 Layout.....	21
7.2 ESD Ratings.....	6	11 Device and Documentation Support	23
7.3 Recommended Operating Conditions.....	6	11.1 Documentation Support.....	23
7.4 Thermal Information.....	7	11.2 サポート・リソース.....	23
7.5 Electrical Characteristics.....	7	11.3 Trademarks.....	23
7.6 Typical Characteristics.....	10	11.4 静電気放電に関する注意事項.....	23
8 Parameter Measurement Information	11	11.5 用語集.....	23
9 Detailed Description	13	12 Mechanical, Packaging, and Orderable Information	23
9.1 Overview.....	13		

4 Revision History

資料番号末尾の英字は改訂を表しています。その改訂履歴は英語版に準じています。

Changes from Revision * (September 2021) to Revision A (June 2023)

	Page
• LMK1D1208P データシートのリリースに合わせてデータシートのフォーマットを更新.....	1
• 表のタイトルを「製品情報」から「パッケージ情報」に変更。.....	1
• Added information to the <i>Fail-Safe Input</i> section.....	14
• Removed the word 'or' in the phrase 'In this example, the PHY, ASIC, FPGA and CPU'.....	18
• Moved the <i>Power Supply Recommendations</i> and <i>Layout</i> section to the <i>Application and Implementation</i> section.....	20
• Changed 0.1 μ F (x3) to 0.1 μ F (x4) in ☒ 10-4	20

5 Device Comparison

表 5-1. Device Comparison

DEVICE	DEVICE TYPE	FEATURES	OUTPUT SWING	PACKAGE	BODY SIZE
LMK1D2108	Dual 1:8	Global output enable and swing control via pin control	350 mV	VQFN (48)	7.00 mm × 7.00 mm
			500 mV		
LMK1D2106	Dual 1:6	Global output enable and swing control via pin control	350 mV	VQFN (40)	6.00 mm × 6.00 mm
			500 mV		
LMK1D2104	Dual 1:4	Global output enable and swing control via pin control	350 mV	VQFN (28)	5.00 mm × 5.00 mm
			500 mV		
LMK1D2102	Dual 1:2	Global output enable and swing control via pin control	350 mV	VQFN (16)	3.00 mm × 3.00 mm
			500 mV		
LMK1D1216	2:16	Global output enable control via pin control	350 mV	VQFN (48)	7.00 mm × 7.00 mm
			500 mV		
LMK1D1212	2:12	Global output enable control via pin control	350 mV	VQFN (40)	6.00 mm × 6.00 mm
			500 mV		
LMK1D1208P	2:8	Individual output enable control via pin control	350 mV	VQGN (40)	6.00 mm × 6.00 mm
			500 mV		
LMK1D1208I	2:8	Individual output enable control via I2C	350 mV	VQFN (40)	6.00 mm × 6.00 mm
			500 mV		
LMK1D1208	2:8	Global output enable control via pin control	350 mV	VQFN (28)	5.00 mm × 5.00 mm
LMK1D1204P	2:4	Individual output enable control via pin control	350 mV	VQGN (28)	5.00 mm × 5.00 mm
LMK1D1204	2:4	Global output enable control via pin control	350 mV	VQFN (16)	3.00 mm × 3.00 mm

6 Pin Configuration and Functions



图 6-1. LMK1D1204P: RHD Package 28-Pin VQFN Top View

表 6-1. Pin Functions

NAME	NO.	TYPE ⁽¹⁾	DESCRIPTION
DIFFERENTIAL/SINGLE-ENDED CLOCK INPUT			
IN0_P	9	I	Primary: Differential input pair or single-ended input
IN0_N	10		
IN1_P	5	I	Secondary: Differential input pair or single-ended input. Note that INP0, INN0 are used indistinguishably with IN0_P, IN0_N.
IN1_N	6		
INPUT SELECT			
IN_SEL	2	I	Input Selection with an internal 500-kΩ pullup and 320-kΩ pulldown, selects input port. See 表 9-1.
OUTPUT ENABLE			
OE0	13	I	Output Enable for channel 0 HIGH (default): Enable output channel 0 LOW: Disable output channel 0 in Hi-Z state
OE1	19	I	Output Enable for channel 1 HIGH (default): Enable output channel 1 LOW: Disable output channel 1 in Hi-Z state
OE2	24	I	Output Enable for channel 2 HIGH (default): Enable output channel 2 LOW: Disable output channel 2 in Hi-Z state
OE3	3	I	Output Enable for channel 3 HIGH (default): Enable output channel 3 LOW: Disable output channel 3 in Hi-Z state
BIAS VOLTAGE OUTPUT			
VAC_REF0	11	O	Bias voltage output for capacitive-coupled inputs. If used, TI recommends using a 0.1-μF capacitor to GND on this pin.
VAC_REF1	7		
DIFFERENTIAL CLOCK OUTPUT			
OUT0_P	16	O	Differential LVDS output pair number 0
OUT0_N	17		

表 6-1. Pin Functions (continued)

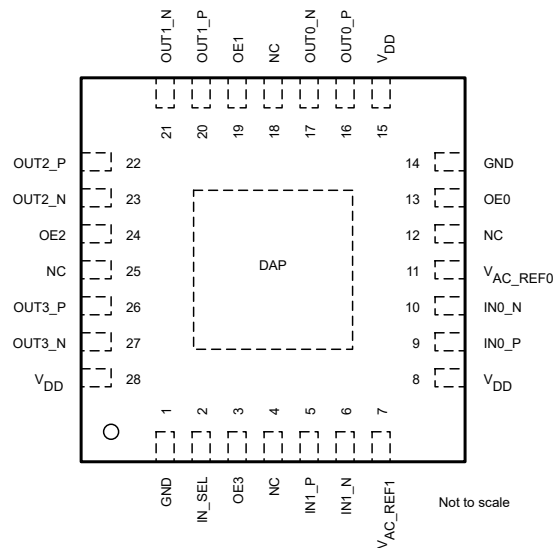
NAME	NO.	TYPE ⁽¹⁾	DESCRIPTION
OUT1_P	20	O	Differential LVDS output pair number 1
OUT1_N	21		
OUT2_P	22	O	Differential LVDS output pair number 2
OUT2_N	23		
OUT3_P	26	O	Differential LVDS output pair number 3
OUT3_N	27		
SUPPLY VOLTAGE			
V _{DD}	8, 15, 28	P	Device power supply (1.8 V, 2.5 V, or 3.3 V)
GROUND			
GND	1, 14	G	Ground
MISC			
DAP	DAP	GND	Die Attach Pad. Connect to the printed circuit board (PCB) ground plane for heat dissipation.
NC	4, 12, 18, 25	NC	No Connection. Leave floating

(1) G = Ground, I = Input, O = Output, P = Power

7 Specifications

7.1 Absolute Maximum Ratings

over operating free-air temperature range (unless otherwise noted)⁽¹⁾

		MIN	MAX	UNIT
V _{DD}	Supply voltage	-0.3	3.6	V
V _{IN}	Input voltage	-0.3	3.6	V
V _O	Output voltage	-0.3	V _{DD} + 0.3	V
I _{IN}	Input current	-20	20	mA
I _O	Continuous output current	-50	50	mA
T _J	Junction temperature		135	°C
T _{stg}	Storage temperature ⁽²⁾	-65	150	°C

(1) Operation outside the *Absolute Maximum Ratings* may cause permanent device damage. *Absolute Maximum Ratings* do not imply functional operation of the device at these or any other conditions beyond those listed under *Recommended Operating Conditions*. If used outside the *Recommended Operating Conditions* but within the *Absolute Maximum Ratings*, the device may not be fully functional, and this may affect device reliability, functionality, performance, and shorten the device lifetime.

(2) Device unpowered

7.2 ESD Ratings

			VALUE	UNIT
V _(ESD)	Electrostatic discharge	Human body model (HBM), per ANSI/ESDA/ JEDEC JS-001, all pins ⁽¹⁾	±3000	V
		Charged device model (CDM), per ANSI/ESDA/ JEDEC JS-002, all pins ⁽²⁾	±1000	

(1) JEDEC document JEP155 states that 500-V HBM allows safe manufacturing with a standard ESD control process.

(2) JEDEC document JEP157 states that 250-V CDM allows safe manufacturing with a standard ESD control process.

7.3 Recommended Operating Conditions

over operating free-air temperature range (unless otherwise noted)

			MIN	NOM	MAX	UNIT
V _{DD}	Core supply voltage	3.3-V supply	3.135	3.3	3.465	V
		2.5-V supply	2.375	2.5	2.625	
		1.8-V supply	1.71	1.8	1.89	
Supply Ramp	Supply voltage ramp	Requires monotonic ramp (10-90% of V _{DD})	0.1		20	ms
T _A	Operating free-air temperature		-40		105	°C
T _J	Operating junction temperature		-40		135	°C

7.4 Thermal Information

THERMAL METRIC ⁽¹⁾		LMK1D1204P	UNIT
		RHD (VQFN)	
		28 PINS	
R _{θJA}	Junction-to-ambient thermal resistance	38.9	°C/W
R _{θJC(top)}	Junction-to-case (top) thermal resistance	32.1	°C/W
R _{θJB}	Junction-to-board thermal resistance	18.7	°C/W
Ψ _{JT}	Junction-to-top characterization parameter	1	°C/W
Ψ _{JB}	Junction-to-board characterization parameter	18.7	°C/W
R _{θJC(bot)}	Junction-to-case (bottom) thermal resistance	8.2	°C/W

(1) For more information about traditional and new thermal metrics, see the [Semiconductor and IC Package Thermal Metrics](#) application report.

7.5 Electrical Characteristics

V_{DD} = 1.8 V ± 5 %, –40°C ≤ T_A ≤ 105°C. Typical values are at V_{DD} = 1.8 V, 25°C (unless otherwise noted)

PARAMETER		TEST CONDITIONS	MIN	TYP	MAX	UNIT
POWER SUPPLY CHARACTERISTICS						
IDD _{STAT}	LMK1D1204P	All-outputs enabled and unterminated, f = 0 Hz ⁽¹⁾		50		mA
IDD _{100M}	LMK1D1204P	All-outputs enabled, R _L = 100 Ω, f = 100 MHz		60	72	mA
INPUT CHARACTERISTICS (Applies to V_{DD} = 1.8 V ± 5%, 2.5 V ± 5% and 3.3 V ± 5%)						
V _{dI3}	3-state input	Open		0.4 × V _{CC}		V
V _{IH}	Input high voltage	Minimum input voltage for a logical "1" state	0.7 × V _{CC}		V _{CC} + 0.3	V
V _{IL}	Input low voltage	Maximum input voltage for a logical "0" state	–0.3		0.3 × V _{CC}	V
I _{IH}	Input high current	V _{DD} can be 1.8V/2.5V/3.3V with V _{IH} = V _{DD}			30	μA
I _{IL}	Input low current	V _{DD} can be 1.8V/2.5V/3.3V with V _{IH} = V _{DD}	–30			μA
R _{pull-up(EN)}	Input pullup resistor			500		kΩ
R _{pull-down(EN)}	Input pulldown resistor			320		kΩ
SINGLE-ENDED LVCMOS/LVTTL CLOCK INPUT (Applies to V_{DD} = 1.8 V ± 5%, 2.5 V ± 5% and 3.3 V ± 5%)						
f _{IN}	Input frequency	Clock input	DC		250	MHz
V _{IN_S-E}	Single-ended Input Voltage Swing	Assumes a square wave input with two levels	0.4		3.465	V
dVIN/dt	Input Slew Rate (20% to 80% of the amplitude)		0.05			V/ns
I _{IH}	Input high current	V _{DD} = 3.465 V, V _{IH} = 3.465 V			50	μA
I _{IL}	Input low current	V _{DD} = 3.465 V, V _{IL} = 0 V	–30			μA
C _{IN_SE}	Input capacitance	at 25°C		3.5		pF
DIFFERENTIAL CLOCK INPUT (Applies to V_{DD} = 1.8 V ± 5%, 2.5 V ± 5% and 3.3 V ± 5%)						
f _{IN}	Input frequency	Clock input			2	GHz
V _{IN,DIFF(P-P)}	Differential input voltage peak-to-peak {2*(V _{INP} -V _{INN})}	V _{ICM} = 1 V (V _{DD} = 1.8 V)	0.3		2.4	V _{PP}
		V _{ICM} = 1.25 V (V _{DD} = 2.5 V/3.3 V)	0.3		2.4	
V _{ICM}	Input common mode voltage	V _{IN,DIFF(P-P)} > 0.4 V (V _{DD} = 1.8 V/2.5/3.3 V)	0.25		2.3	V
I _{IH}	Input high current	V _{DD} = 3.465 V, V _{INP} = 2.4 V, V _{INN} = 1.2 V			30	μA

V_{DD} = 1.8 V ± 5 %, –40°C ≤ T_A ≤ 105°C. Typical values are at V_{DD} = 1.8 V, 25°C (unless otherwise noted)

PARAMETER		TEST CONDITIONS	MIN	TYP	MAX	UNIT
I _{IL}	Input low current	V _{DD} = 3.465 V, V _{INP} = 0 V, V _{INN} = 1.2 V	–30			μA
C _{IN,S-E}	Input capacitance (Single-ended)	at 25°C		3.5		pF
LVDS DC OUTPUT CHARACTERISTICS						
VOD	Differential output voltage magnitude V _{OUTP} - V _{OUTN}	V _{IN,DIFF(P-P)} = 0.3 V, R _{LOAD} = 100 Ω	250	350	450	mV
ΔVOD	Change in differential output voltage magnitude. Per output, defined as the difference between VOD in logic hi/lo states.	V _{IN,DIFF(P-P)} = 0.3 V, R _{LOAD} = 100 Ω	–15		15	mV
V _{OC(SS)}	Steady-state common mode output voltage	V _{IN,DIFF(P-P)} = 0.3 V, R _{LOAD} = 100 Ω (V _{DD} = 1.8 V)	1		1.2	V
		V _{IN,DIFF(P-P)} = 0.3 V, R _{LOAD} = 100 Ω (V _{DD} = 2.5 V/3.3 V)	1.1		1.375	
ΔV _{OC(SS)}	Change in steady-state common mode output voltage. Per output, defined as the difference in VOC in logic hi/lo states.	V _{IN,DIFF(P-P)} = 0.3 V, R _{LOAD} = 100 Ω	–15		15	mV
LVDS AC OUTPUT CHARACTERISTICS						
V _{ring}	Output overshoot and undershoot	V _{IN,DIFF(P-P)} = 0.3 V, R _{LOAD} = 100 Ω, f _{OUT} = 491.52 MHz	–0.1		0.1	V _{OD}
V _{OS}	Output AC common mode	V _{IN,DIFF(P-P)} = 0.3 V, R _{LOAD} = 100 Ω		50	100	mV _{pp}
I _{OS}	Short-circuit output current (differential)	V _{OUTP} = V _{OUTN}	–12		12	mA
I _{OS(cm)}	Short-circuit output current (common-mode)	V _{OUTP} = V _{OUTN} = 0	–24		24	mA
t _{PD}	Propagation delay	V _{IN,DIFF(P-P)} = 0.3 V, R _{LOAD} = 100 Ω ⁽²⁾	0.3		0.575	ns
t _{SK,O}	Output skew	Skew between outputs with the same load conditions			20	ps
t _{SK,PP}	Part-to-part skew	Skew between outputs on different parts subjected to the same operating conditions with the same input and output loading.			250	ps
t _{SK,P}	Pulse skew	50% duty cycle input, crossing point-to-crossing-point distortion ⁽⁴⁾	–20		20	ps
t _{RJIT(ADD)}	Random additive Jitter (rms)	f _{IN} = 156.25 MHz with 50% duty-cycle, Input slew rate = 1.5V/ns, Integration range = 12 kHz – 20 MHz, with output load R _{LOAD} = 100 Ω		50	60	fs, RMS
Phase noise	Phase Noise for a carrier frequency of 156.25 MHz with 50% duty-cycle, Input slew rate = 1.5V/ns with output load R _{LOAD} = 100 Ω	PN _{1kHz}		–143		dBc/Hz
		PN _{10kHz}		–152		
		PN _{100kHz}		–157		
		PN _{1MHz}		–160		
		PN _{floor}		–164		
MUX _{ISO}	Mux Isolation	f _{IN} = 156.25 MHz. The difference in power level at f _{IN} when the selected clock is active and the unselected clock is static versus when the selected clock is inactive and the unselected clock is active.		80		dB
ODC	Output duty cycle	With 50% duty cycle input	45		55	%

$V_{DD} = 1.8\text{ V} \pm 5\%$, $-40^{\circ}\text{C} \leq T_A \leq 105^{\circ}\text{C}$. Typical values are at $V_{DD} = 1.8\text{ V}$, 25°C (unless otherwise noted)

PARAMETER		TEST CONDITIONS	MIN	TYP	MAX	UNIT
t_R/t_F	Output rise and fall time	20% to 80% with $R_{LOAD} = 100\ \Omega$			300	ps
V_{AC_REF}	Reference output voltage	$V_{DD} = 2.5\text{ V}$, $I_{LOAD} = 100\ \mu\text{A}$	0.9	1.25	1.375	V
POWER SUPPLY NOISE REJECTION (PSNR) $V_{DD} = 2.5\text{ V}/3.3\text{ V}$						
PSNR	Power Supply Noise Rejection ($f_{carrier} = 156.25\text{ MHz}$)	10 kHz, 100 mVpp ripple injected on V_{DD}		-70		dBc
		1 MHz, 100 mVpp ripple injected on V_{DD}		-50		

- (1) A typical 4-mA current reduction per disabled output can be expected.
- (2) Measured between single-ended/differential input crossing point to the differential output crossing point.
- (3) Defined as the magnitude of the time difference between the high-to-low and low-to-high propagation delay times at an output.

7.6 Typical Characteristics

Figure 7-1 captures the variation of the LMK1D1204P current consumption with input frequency and supply voltage. Figure 7-2 shows the variation of the differential output voltage (VOD) swept across frequency.

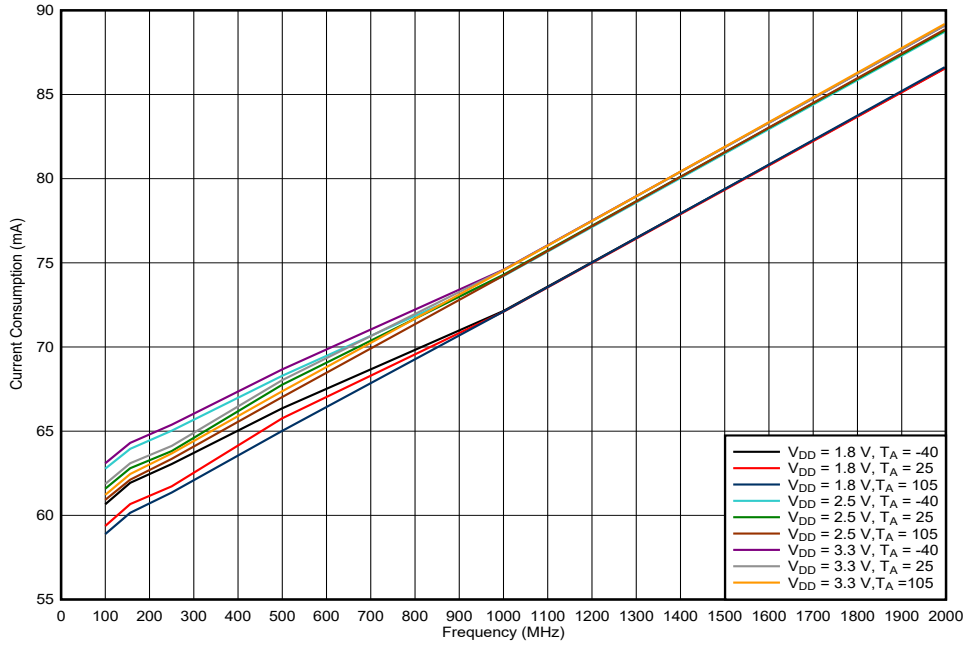

Figure 7-1. LMK1D1204P Current Consumption vs Frequency

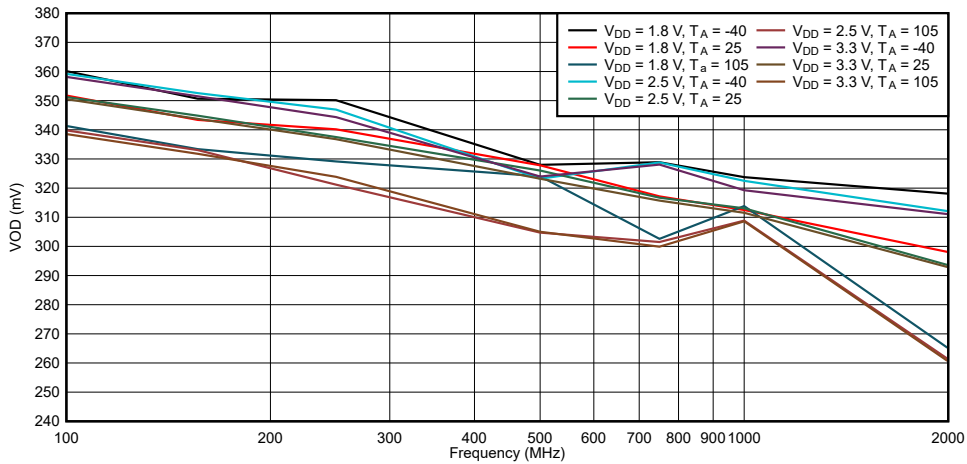
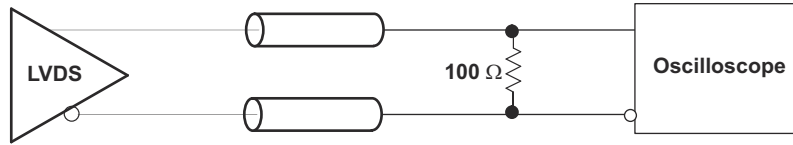
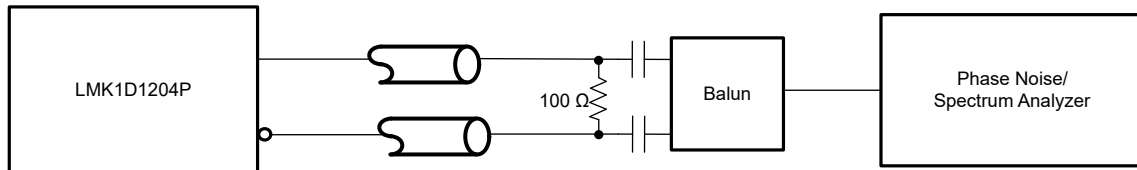

Figure 7-2. LMK1D1204P VOD vs Frequency

8 Parameter Measurement Information



8-1. LVDS Output DC Configuration During Device Test



8-2. LVDS Output AC Configuration During Device Test

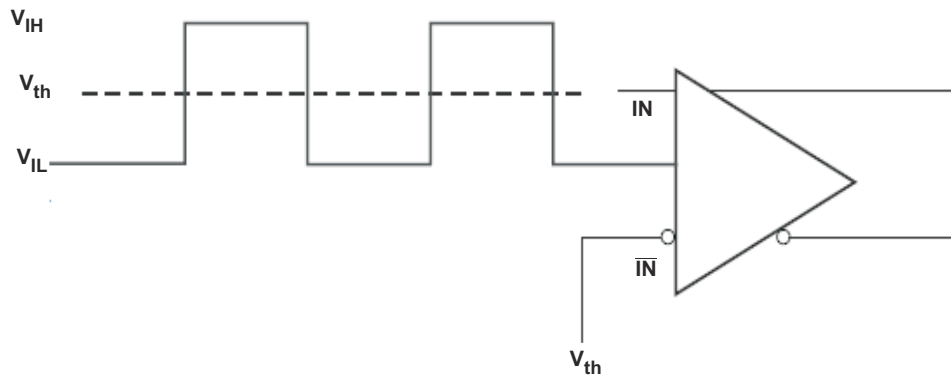

8-3. DC-Coupled LVCMOS Input During Device Test

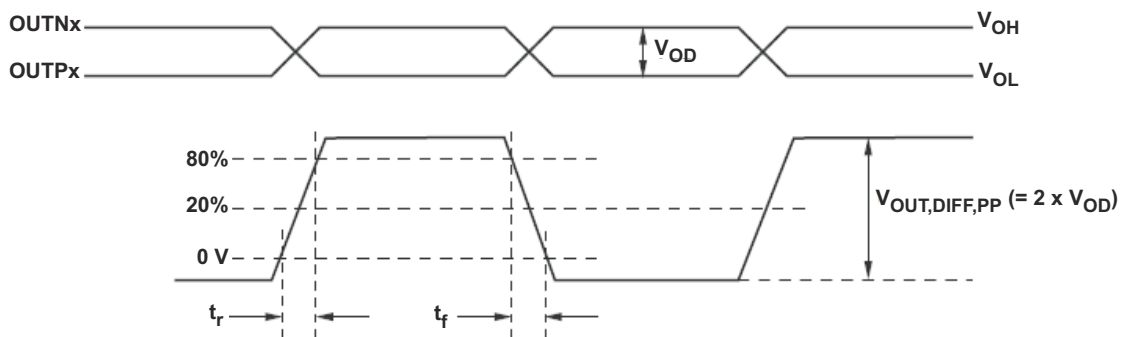

8-4. Output Voltage and Rise/Fall Time

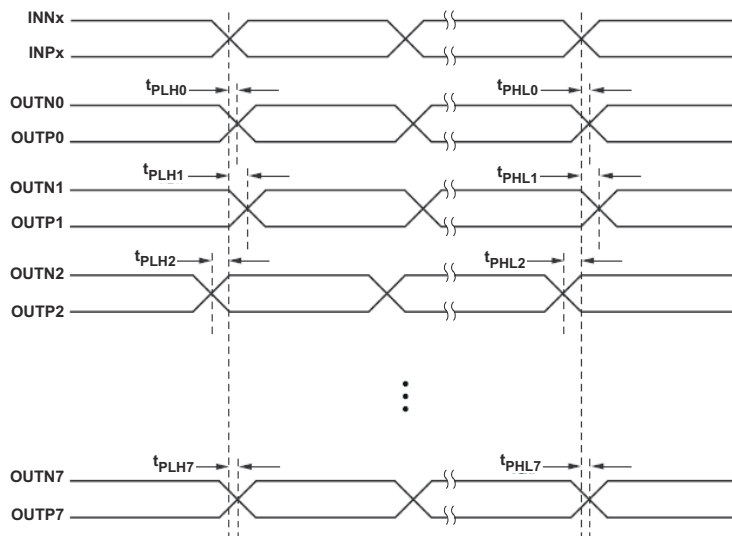

- A. Output skew is calculated as the greater of the following: the difference between the fastest and the slowest t_{PLHn} or the difference between the fastest and the slowest t_{PHLn} ($n = 0, 1, 2, \dots, 7$)
- B. Part to part skew is calculated as the greater of the following: the difference between the fastest and the slowest t_{PLHn} or the difference between the fastest and the slowest t_{PHLn} across multiple devices ($n = 0, 1, 2, \dots, 7$)

8-5. Output Skew and Part-to-Part Skew

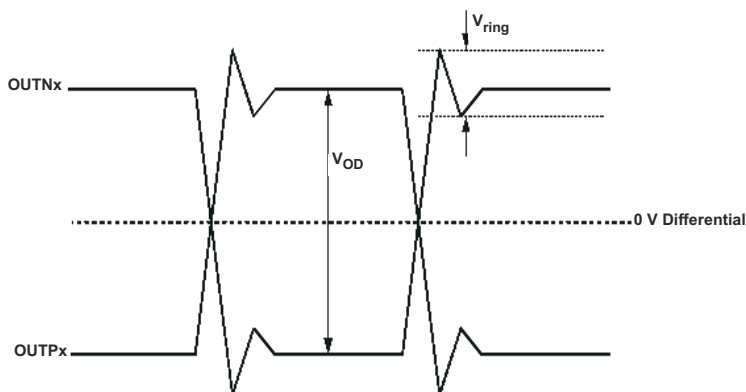

8-6. Output Overshoot and Undershoot

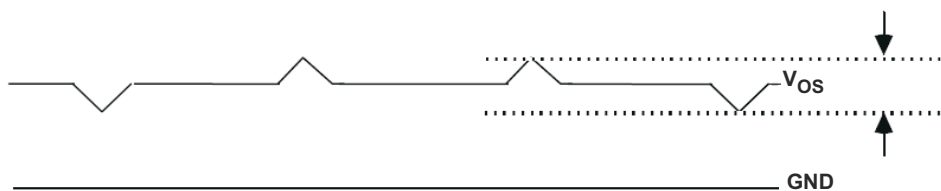

8-7. Output AC Common Mode

9 Detailed Description

9.1 Overview

The LMK1D1204P LVDS drivers use CMOS transistors to control the output current. Therefore, proper biasing and termination are required to ensure correct operation of the device and to maximize signal integrity.

The proper LVDS termination for signal integrity over two 50-Ω lines is 100 Ω between the outputs on the receiver end. Either DC-coupled termination or AC-coupled termination can be used for LVDS outputs. TI recommends placing a termination resistor close to the receiver. If the receiver is internally biased to a voltage different than the output common-mode voltage of the LMK1D1204P, AC coupling must be used. If the LVDS receiver has internal 100-Ω termination, external termination must be omitted.

9.2 Functional Block Diagram

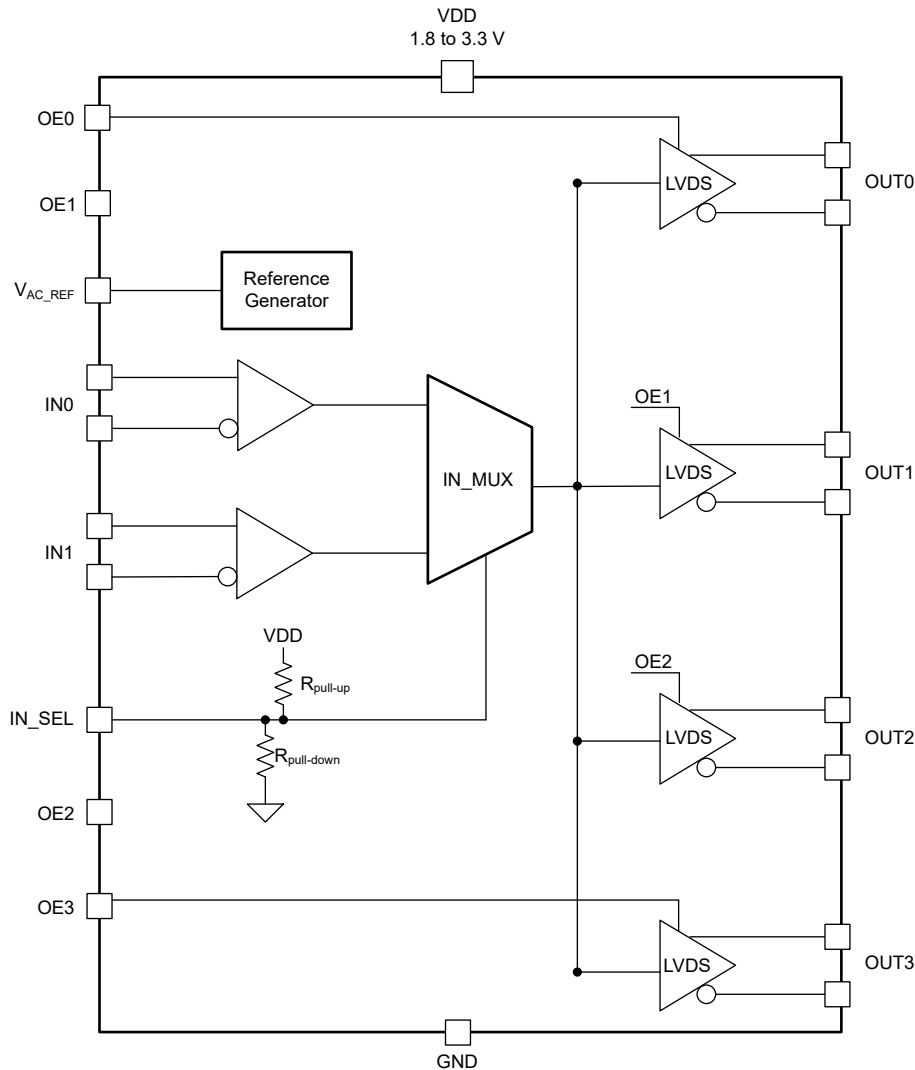

9.3 Feature Description

The LMK1D1204P is a low additive jitter LVDS fan-out buffer that can generate up to four copies of two selectable LVPECL, LVDS, HCSL, CML, or LVCMOS inputs. The LMK1D1204P can accept reference clock frequencies up to 2 GHz while providing low output skew.

9.3.1 Fail-Safe Input

The LMK1D120x family of devices is designed to support fail-safe input operation feature. This feature allows the user to drive the device inputs before V_{DD} is applied without damaging the device. Refer to [Specifications](#) for more information on the maximum input supported by the device. The user should note that incorporating the fail-safe inputs also results in a slight increase in clock input pin capacitance. The device also incorporates an input hysteresis which prevents random oscillation in absence of an input signal. Furthermore, this feature allows the input pins to be left open.

9.4 Device Functional Modes

The two inputs of the LMK1D1204P are internally muxed together and can be selected through the control pin (see [表 9-1](#)). Unused inputs can be left floating to reduce overall component cost. Both AC- and DC-coupling schemes can be used with the LMK1D1204P to provide greater system flexibility.

表 9-1. Input Selection Table

IN_SEL	ACTIVE CLOCK INPUT
0	IN0_P, IN0_N
1	IN1_P, IN1_N
Open	None ⁽¹⁾

- (1) The input buffers are disabled and the state of the outputs are dependent on the state of OEx (see [表 9-2](#)). If OEx = 0, the corresponding output will be disabled in Hi-Z state, whereas if OEx = 1 (default), the corresponding output will be logic low.

The outputs of the LMK1D1204P can be individually enabled or disabled using the OEx hardware pins (see [表 9-2](#)). The disabled state of the outputs is Hi-Z (high impedance) as this reduces the power consumption and also prevents back-biasing of the devices connected to these outputs.

Unused outputs should be disabled to eliminate the need for a termination resistor. In the case of enabled unused outputs, TI recommends a 100-Ω termination for optimal performance.

表 9-2. Output Control

OEx	CLOCK OUTPUTS
0	OUTPx, OUTNx disabled in Hi-Z state
1 (default)	OUTPx, OUTNx enabled

9.4.1 LVDS Output Termination

TI recommends that unused outputs are terminated differentially with a 100-Ω resistor for optimum performance, although unterminated outputs are also okay but will result in slight degradation in performance (Output AC common-mode V_{OS}) in the outputs being used.

The LMK1D1204P can be connected to LVDS receiver inputs with DC and AC coupling as shown in [图 9-1](#) and [图 9-2](#), respectively.

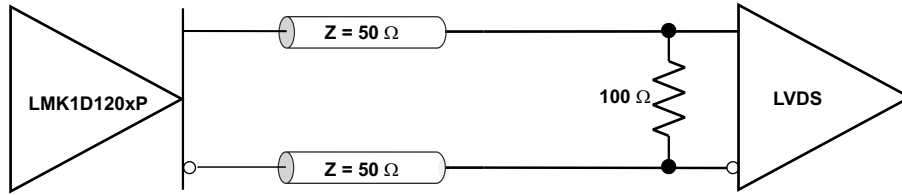

9-1. Output DC Termination

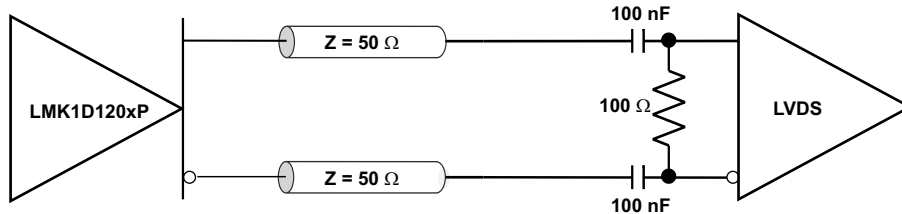

9-2. Output AC Termination (With the Receiver Internally Biased)

9.4.2 Input Termination

The LMK1D1204P inputs can be interfaced with LVDS, LVPECL, HCSL, or LVCMOS drivers.

LVDS drivers can be connected to LMK1D1204P inputs with DC and AC coupling as shown 9-3 and 9-4, respectively.

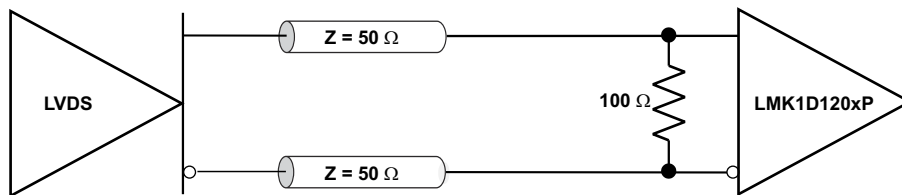

9-3. LVDS Clock Driver Connected to LMK1D1204P Input (DC-Coupled)

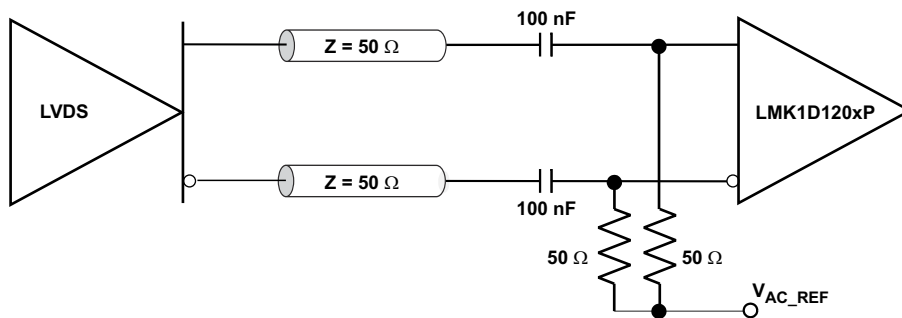

9-4. LVDS Clock Driver Connected to LMK1D1204P Input (AC-Coupled)

9-5 shows how to connect LVPECL inputs to the LMK1D1204P. The series resistors are required to reduce the LVPECL signal swing if the signal swing is $>1.6 V_{PP}$.

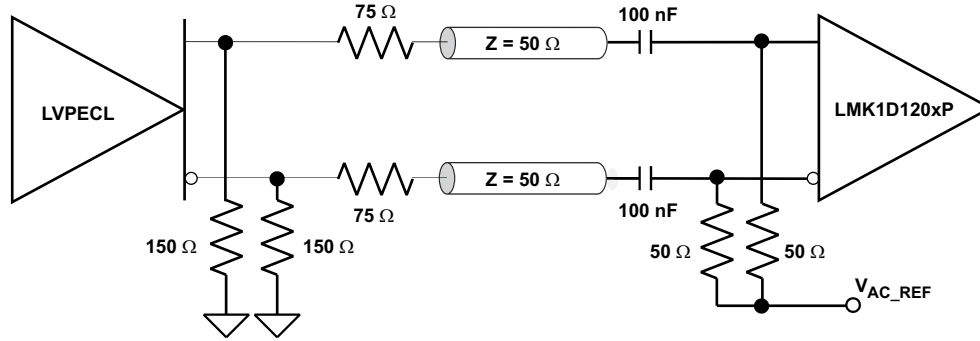

Figure 9-5. LVPECL Clock Driver Connected to LMK1D1204P Input

Figure 9-6 shows how to couple a LVCMOS clock input to the LMK1D1204P directly.

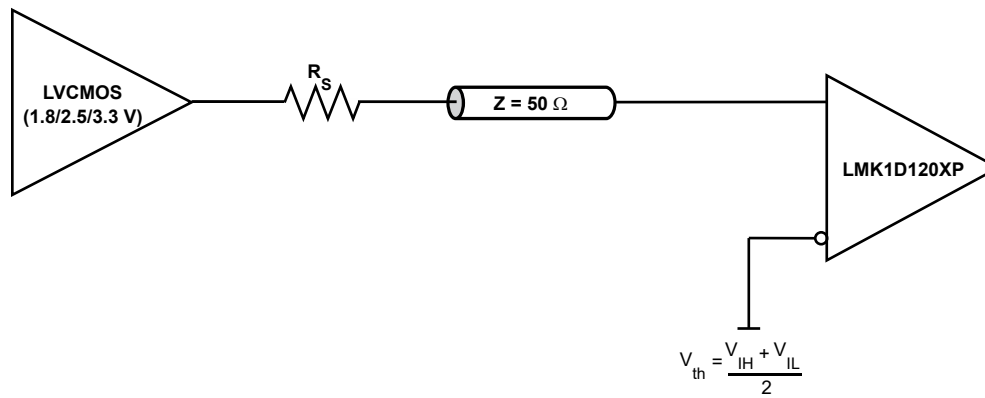

Figure 9-6. 1.8-V, 2.5-V, or 3.3-V LVCMOS Clock Driver Connected to LMK1D1204P Input

For unused input, TI recommends grounding both input pins (INP, INN) using 1-kΩ resistors.

10 Application and Implementation

注

Information in the following applications sections is not part of the TI component specification, and TI does not warrant its accuracy or completeness. TI's customers are responsible for determining suitability of components for their purposes, as well as validating and testing their design implementation to confirm system functionality.

10.1 Application Information

The LMK1D1204P is a low additive jitter universal to LVDS fan-out buffer with two selectable inputs and pin controlled output enables. The small package size, low output skew, low propagation delay and low additive jitter of this device is designed for applications that require high-performance clock distribution as well as for low-power and space-constraint applications.

10.2 Typical Application



图 10-1. Fan-Out Buffer for Line Card Application

10.2.1 Design Requirements

The LMK1D1204P shown in [Figure 10-1](#) is configured to select two inputs: a 156.25-MHz LVDS clock from the backplane, or a secondary 156.25-MHz, LVCMOS, 2.5-V oscillator. The LVDS clock is AC-coupled and biased using the integrated reference voltage generator. A resistor divider is used to set the threshold voltage correctly for the LVCMOS clock. 0.1- μ F capacitors are used to reduce noise on both V_{AC_REF} and $SECRET_N$. Either input signal can be then fanned out to desired devices, as shown. The configuration example is driving 4 LVDS receivers in a line card application with the following properties:

- The PHY device is capable of DC coupling with an LVDS driver such as the LMK1D1204P. This PHY device features internal termination so no additional components are required for proper operation.
- The ASIC LVDS receiver features internal termination and operates at the same common-mode voltage as the LMK1D1204P. Again, no additional components are required.
- The FPGA requires external AC coupling, but has internal termination. 0.1- μ F capacitors are placed to provide AC coupling. Similarly, the CPU is internally terminated, and requires only external AC-coupling capacitors.
- The unused outputs of the LMK1D1204P can be disabled using the corresponding OEx pin. This results in a lower power consumption.

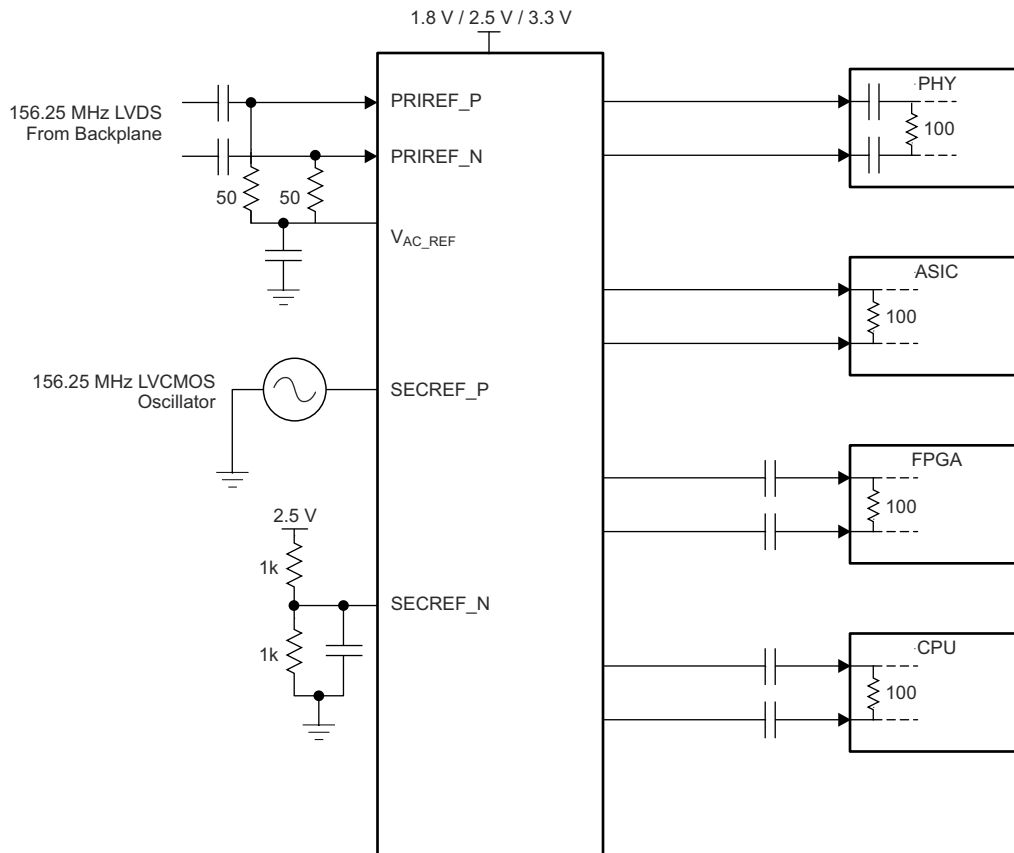
10.2.2 Detailed Design Procedure

See [Input Termination](#) for proper input terminations, dependent on single-ended or differential inputs.

See [LVDS Output Termination](#) for output termination schemes depending on the receiver application.

Unused outputs can be disabled using the corresponding OEx pin setting according to [Table 9-2](#). Disabling the outputs also eliminates requirement of termination resistors.

In this example, the PHY, ASIC, FPGA and CPU require different schemes. Power supply filtering and bypassing is critical for low-noise applications.

See [Power Supply Recommendations](#) for recommended filtering techniques. A reference layout is provided in [Low-Additive Jitter, Four LVDS Outputs Clock Buffer Evaluation Board user's guide](#) (SCAU043).

10.2.3 Application Curves

This section shows the low additive noise for the LMK1D1204P. The low noise 156.25-MHz source with 24-fs RMS jitter shown in [10-2](#) drives the LMK1D1204P, resulting in 46.4-fs RMS when integrated from 12 kHz to 20 MHz (see [10-3](#)). The resultant additive jitter is 39.7-fs RMS for this configuration.

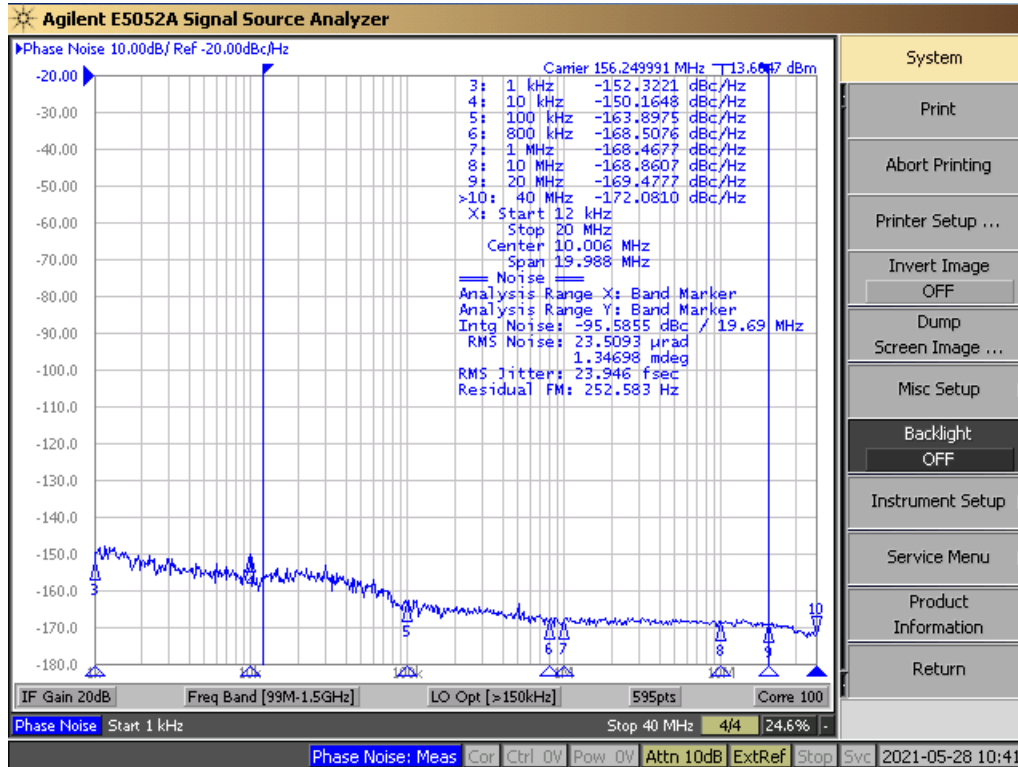

Note: Reference signal is a low-noise Rhode and Schwarz SMA100B

10-2. LMK1D1204P Reference Phase Noise, 156.25 MHz, 24-fs RMS (12 kHz to 20 MHz)

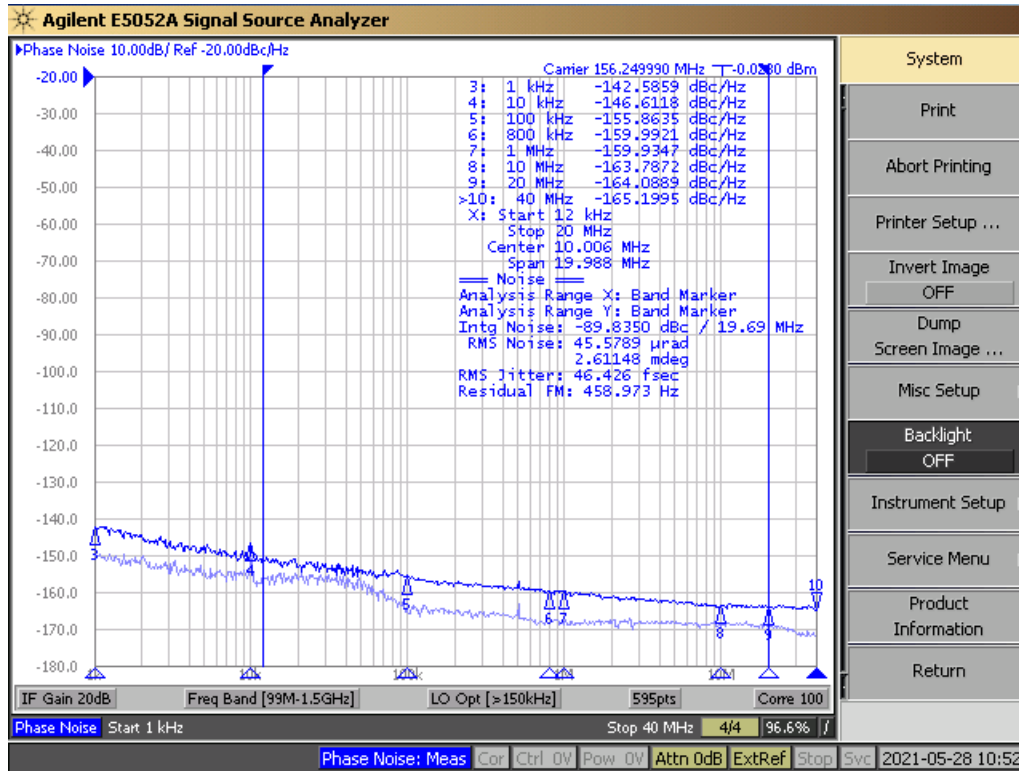

10-3. LMK1D1204P Output Phase Noise, 156.25 MHz, 46.4-fs RMS (12 kHz to 20 MHz)

10.3 Power Supply Recommendations

High-performance clock buffers are sensitive to noise on the power supply, which can dramatically increase the additive jitter of the buffer. Thus, it is essential to reduce noise from the system power supply, especially when jitter or phase noise is critical to applications.

Filter capacitors are used to eliminate the low-frequency noise from the power supply, where the bypass capacitors provide the low impedance path for high-frequency noise and guard the power-supply system against the induced fluctuations. These bypass capacitors also provide instantaneous current surges as required by the device and must have low equivalent series resistance (ESR). To properly use the bypass capacitors, they must be placed close to the power-supply pins and laid out with short loops to minimize inductance. TI recommends adding as many high-frequency (for example, 0.1-µF) bypass capacitors as there are supply pins in the package. TI recommends, but does not require, inserting a ferrite bead between the board power supply and the chip power supply that isolates the high-frequency switching noises generated by the clock driver. These ferrite beads prevent the switching noise from leaking into the board supply. Choose an appropriate ferrite bead with low DC resistance because it is imperative to provide adequate isolation between the board supply and the chip supply, as well as to maintain a voltage at the supply pins that is greater than the minimum voltage required for proper operation.

10-4 shows this recommended power-supply decoupling method.

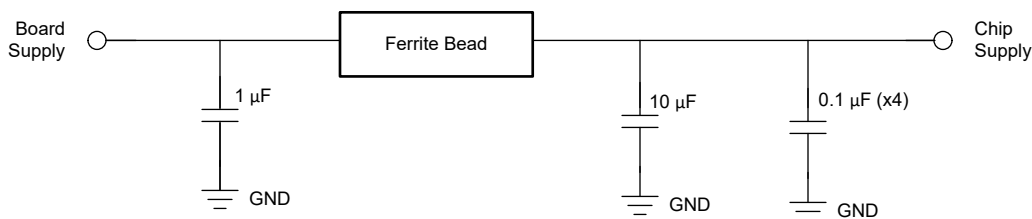

10-4. Power Supply Decoupling

10.4 Layout

10.4.1 Layout Guidelines

For reliability and performance reasons, the die temperature must be limited to a maximum of 135°C.

The device package has an exposed pad that provides the primary heat removal path to the PCB. To maximize the heat dissipation from the package, a thermal landing pattern including multiple vias to a ground plane must be incorporated into the PCB within the footprint of the package. The thermal pad must be soldered down to ensure adequate heat conduction to of the package. [✕ 10-5](#) and [✕ 10-6](#) show the recommended land and via patterns for the 28-pin LMK1D1204P device.

10.4.2 Layout Examples

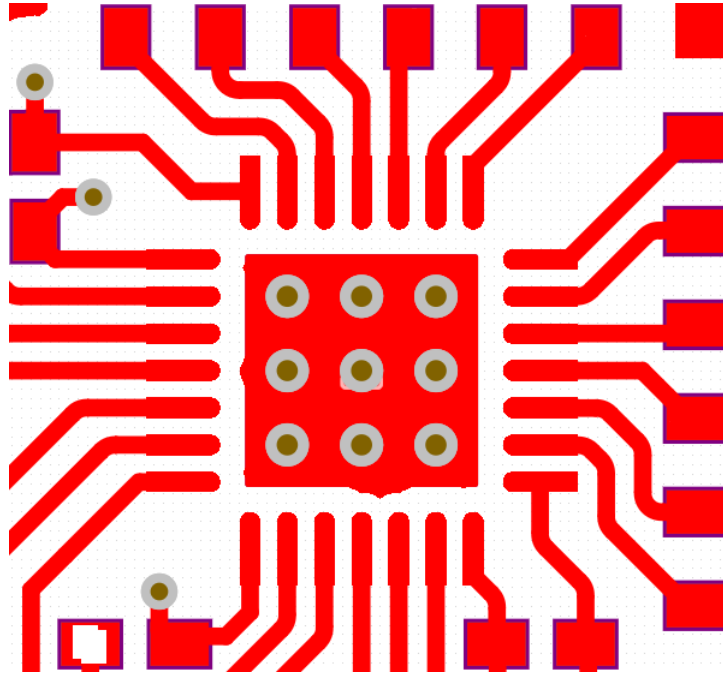

[✕ 10-5](#). Recommended PCB Layout, Top Layer



图 10-6. Recommended PCB Layout, GND Layer

11 Device and Documentation Support

11.1 Documentation Support

11.1.1 Related Documentation

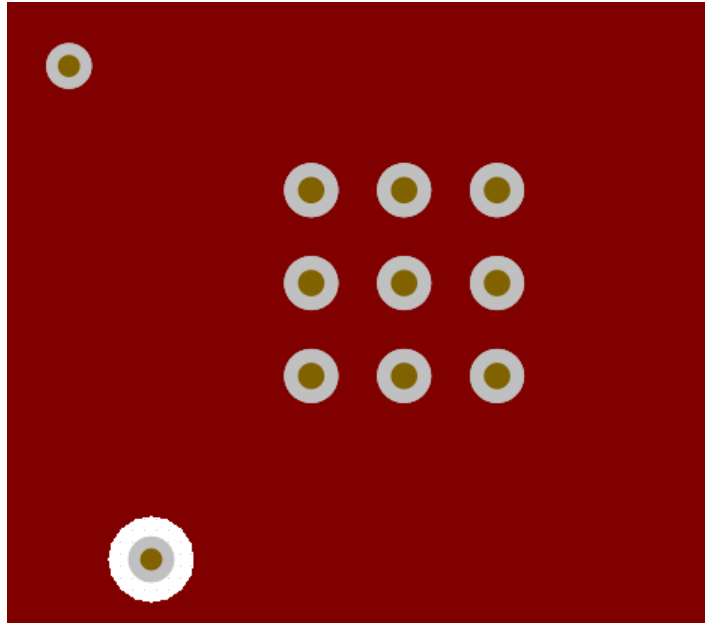
For related documentation see the following:

- Texas Instruments, [Low-Additive Jitter, Four LVDS Outputs Clock Buffer Evaluation Board user's guide](#)
- Texas Instruments, [Power Consumption of LVPECL and LVDS Analog Design Journal](#)
- Texas Instruments, [Using Thermal Calculation Tools for Analog Components application note](#)

11.2 サポート・リソース

TI E2E™ サポート・フォーラムは、エンジニアが検証済みの回答と設計に関するヒントをエキスパートから迅速かつ直接得ることができる場所です。既存の回答を検索したり、独自の質問をしたりすることで、設計に必要な支援を迅速に得ることができます。

リンクされているコンテンツは、該当する貢献者により、現状のまま提供されるものです。これらは TI の仕様を構成するものではなく、必ずしも TI の見解を反映したものではありません。TI の [使用条件](#) を参照してください。

11.3 Trademarks

TI E2E™ is a trademark of Texas Instruments.

すべての商標は、それぞれの所有者に帰属します。

11.4 静電気放電に関する注意事項



この IC は、ESD によって破損する可能性があります。テキサス・インスツルメンツは、IC を取り扱う際には常に適切な注意を払うことを推奨します。正しい取り扱いおよび設置手順に従わない場合、デバイスを破損するおそれがあります。

ESD による破損は、わずかな性能低下からデバイスの完全な故障まで多岐にわたります。精密な IC の場合、パラメータがわずかに変化するだけで公表されている仕様から外れる可能性があるため、破損が発生しやすくなっています。

11.5 用語集

[テキサス・インスツルメンツ用語集](#) この用語集には、用語や略語の一覧および定義が記載されています。

12 Mechanical, Packaging, and Orderable Information

The following pages include mechanical, packaging, and orderable information. This information is the most current data available for the designated devices. This data is subject to change without notice and revision of this document. For browser-based versions of this data sheet, refer to the left-hand navigation.

PACKAGING INFORMATION

Orderable part number	Status (1)	Material type (2)	Package Pins	Package qty Carrier	RoHS (3)	Lead finish/ Ball material (4)	MSL rating/ Peak reflow (5)	Op temp (°C)	Part marking (6)
LMK1D1204PRHDR	Active	Production	VQFN (RHD) 28	3000 LARGE T&R	Yes	POST PLATE AG RING	Level-1-260C-UNLIM	-40 to 105	LMK1D 1204P
LMK1D1204PRHDR.B	Active	Production	VQFN (RHD) 28	3000 LARGE T&R	Yes	POST PLATE AG RING	Level-1-260C-UNLIM	-40 to 105	LMK1D 1204P
LMK1D1204PRHDT	Active	Production	VQFN (RHD) 28	250 SMALL T&R	Yes	POST PLATE AG RING	Level-1-260C-UNLIM	-40 to 105	LMK1D 1204P
LMK1D1204PRHDT.B	Active	Production	VQFN (RHD) 28	250 SMALL T&R	Yes	POST PLATE AG RING	Level-1-260C-UNLIM	-40 to 105	LMK1D 1204P

(1) **Status:** For more details on status, see our [product life cycle](#).

(2) **Material type:** When designated, preproduction parts are prototypes/experimental devices, and are not yet approved or released for full production. Testing and final process, including without limitation quality assurance, reliability performance testing, and/or process qualification, may not yet be complete, and this item is subject to further changes or possible discontinuation. If available for ordering, purchases will be subject to an additional waiver at checkout, and are intended for early internal evaluation purposes only. These items are sold without warranties of any kind.

(3) **RoHS values:** Yes, No, RoHS Exempt. See the [TI RoHS Statement](#) for additional information and value definition.

(4) **Lead finish/Ball material:** Parts may have multiple material finish options. Finish options are separated by a vertical ruled line. Lead finish/Ball material values may wrap to two lines if the finish value exceeds the maximum column width.

(5) **MSL rating/Peak reflow:** The moisture sensitivity level ratings and peak solder (reflow) temperatures. In the event that a part has multiple moisture sensitivity ratings, only the lowest level per JEDEC standards is shown. Refer to the shipping label for the actual reflow temperature that will be used to mount the part to the printed circuit board.

(6) **Part marking:** There may be an additional marking, which relates to the logo, the lot trace code information, or the environmental category of the part.

Multiple part markings will be inside parentheses. Only one part marking contained in parentheses and separated by a "-" will appear on a part. If a line is indented then it is a continuation of the previous line and the two combined represent the entire part marking for that device.

Important Information and Disclaimer: The information provided on this page represents TI's knowledge and belief as of the date that it is provided. TI bases its knowledge and belief on information provided by third parties, and makes no representation or warranty as to the accuracy of such information. Efforts are underway to better integrate information from third parties. TI has taken and continues to take reasonable steps to provide representative and accurate information but may not have conducted destructive testing or chemical analysis on incoming materials and chemicals. TI and TI suppliers consider certain information to be proprietary, and thus CAS numbers and other limited information may not be available for release.

In no event shall TI's liability arising out of such information exceed the total purchase price of the TI part(s) at issue in this document sold by TI to Customer on an annual basis.

TAPE AND REEL INFORMATION

QUADRANT ASSIGNMENTS FOR PIN 1 ORIENTATION IN TAPE

*All dimensions are nominal

Device	Package Type	Package Drawing	Pins	SPQ	Reel Diameter (mm)	Reel Width W1 (mm)	A0 (mm)	B0 (mm)	K0 (mm)	P1 (mm)	W (mm)	Pin1 Quadrant
LMK1D1204PRHDR	VQFN	RHD	28	3000	330.0	12.4	5.3	5.3	1.1	8.0	12.0	Q2
LMK1D1204PRHDT	VQFN	RHD	28	250	180.0	12.4	5.3	5.3	1.1	8.0	12.0	Q2

TAPE AND REEL BOX DIMENSIONS

*All dimensions are nominal

Device	Package Type	Package Drawing	Pins	SPQ	Length (mm)	Width (mm)	Height (mm)
LMK1D1204PRHDR	VQFN	RHD	28	3000	367.0	367.0	35.0
LMK1D1204PRHDT	VQFN	RHD	28	250	210.0	185.0	35.0

GENERIC PACKAGE VIEW

RHD 28

VQFN - 1 mm max height

5 x 5 mm, 0.5 mm pitch

PLASTIC QUAD FLATPACK - NO LEAD

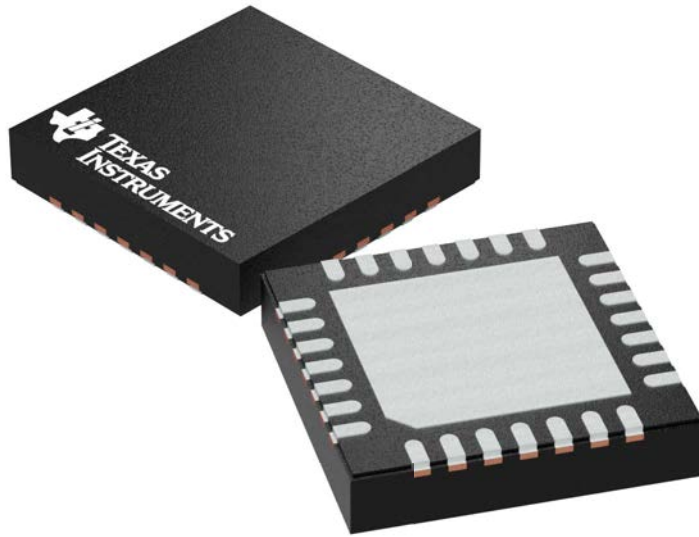

Images above are just a representation of the package family, actual package may vary.
Refer to the product data sheet for package details.

4204400/G

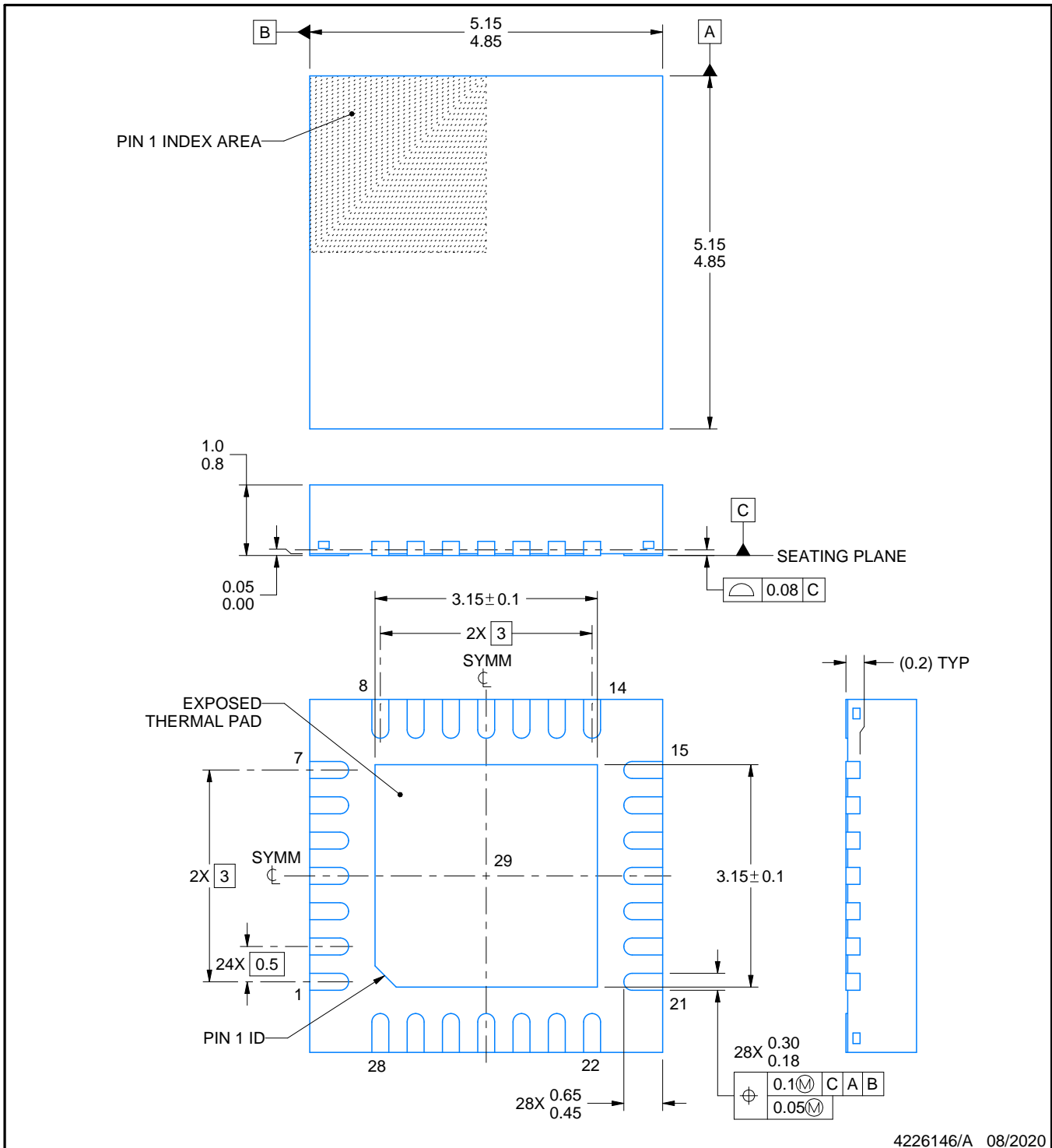
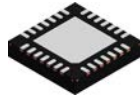

4226146/A 08/2020

NOTES:

1. All linear dimensions are in millimeters. Any dimensions in parenthesis are for reference only. Dimensioning and tolerancing per ASME Y14.5M.
2. This drawing is subject to change without notice.
3. The package thermal pad must be soldered to the printed circuit board for thermal and mechanical performance.

EXAMPLE BOARD LAYOUT

RHD0028B

VQFN - 1 mm max height

PLASTIC QUAD FLATPACK - NO LEAD

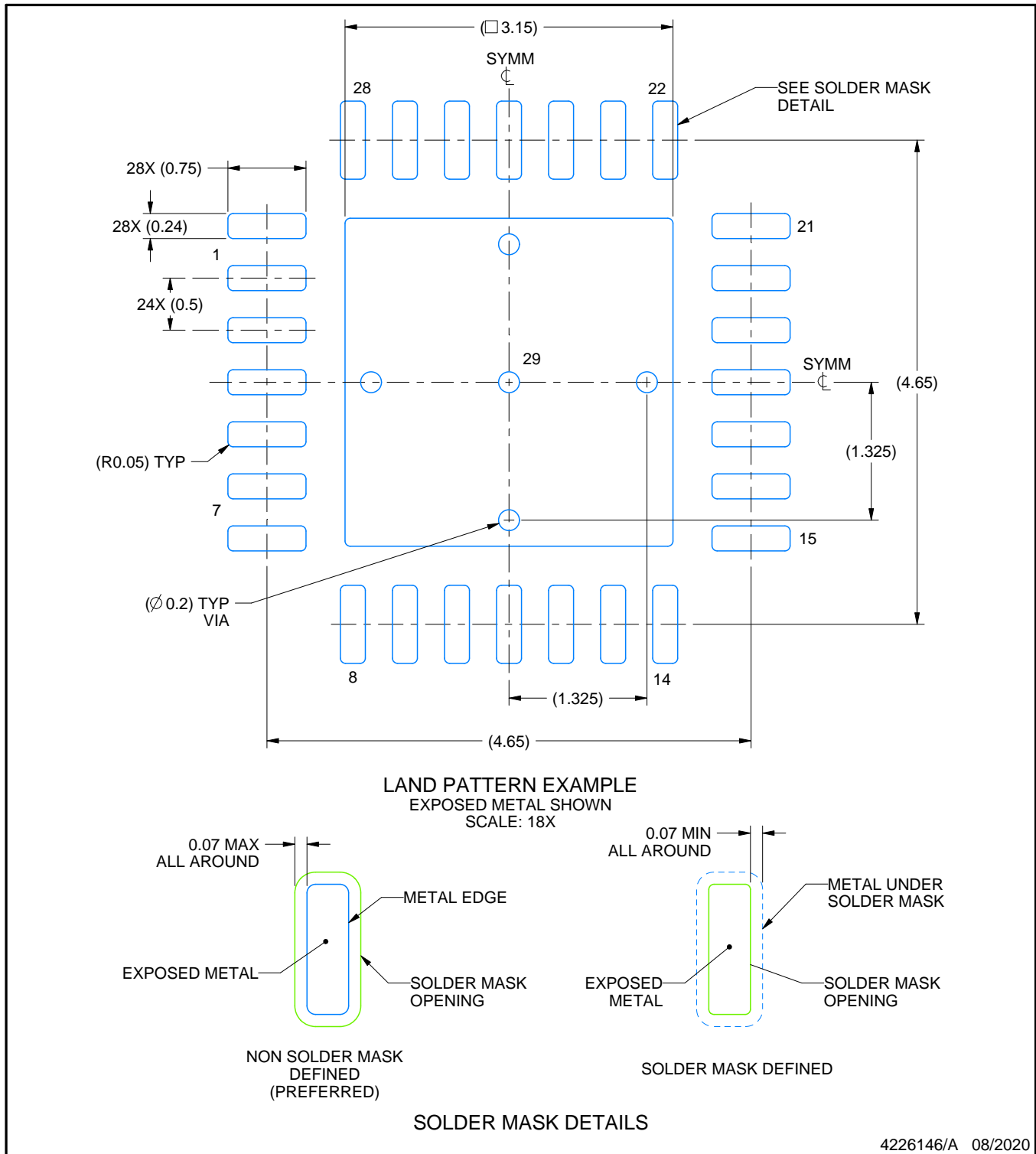

NOTES: (continued)

4. This package is designed to be soldered to a thermal pad on the board. For more information, see Texas Instruments literature number SLUA271 (www.ti.com/lit/sluea271).
5. Vias are optional depending on application, refer to device data sheet. If any vias are implemented, refer to their locations shown on this view. It is recommended that vias under paste be filled, plugged or tented.

EXAMPLE STENCIL DESIGN

RHD0028B

VQFN - 1 mm max height

PLASTIC QUAD FLATPACK - NO LEAD

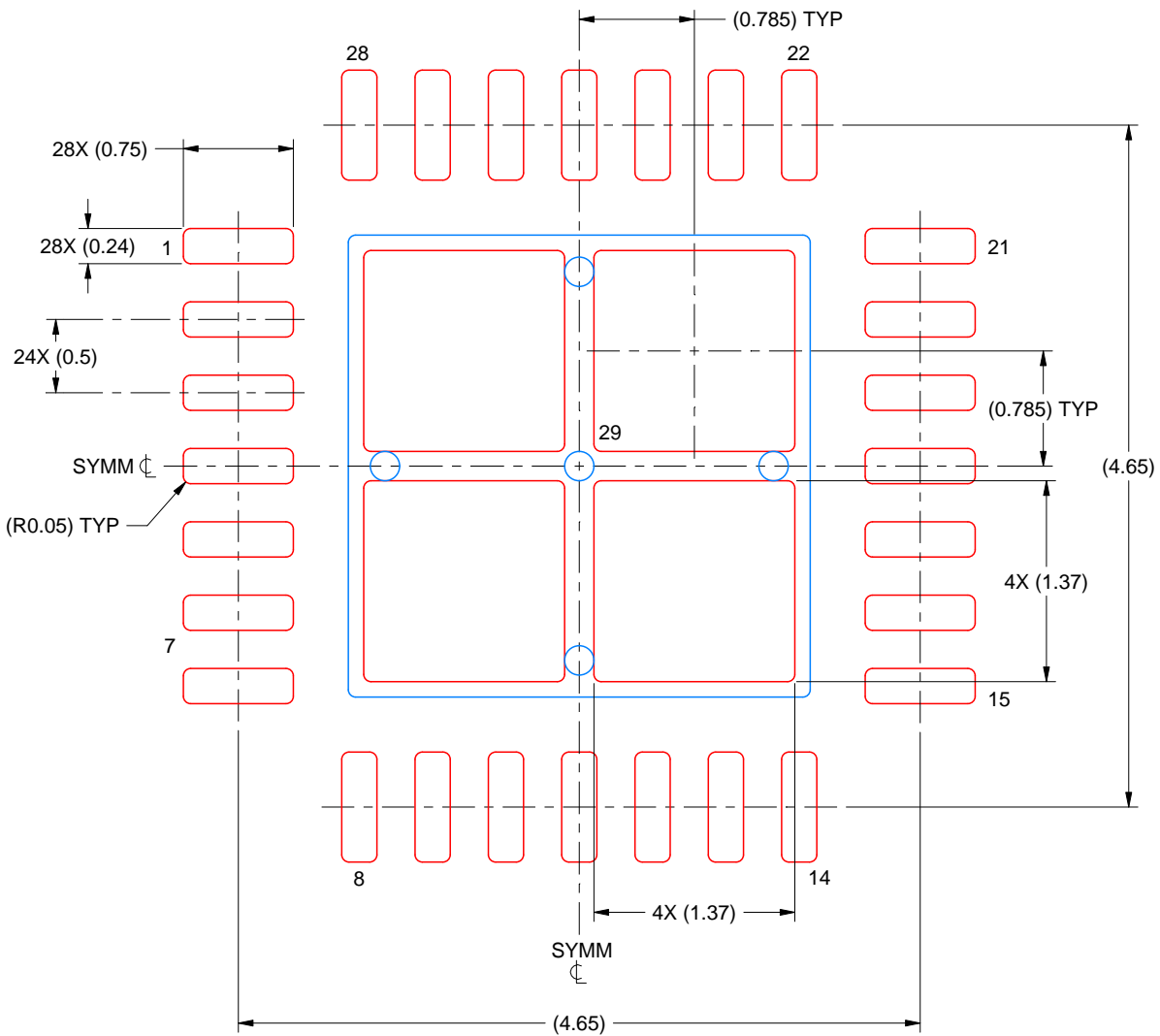

SOLDER PASTE EXAMPLE
 BASED ON 0.125 MM THICK STENCIL
 SCALE: 20X

EXPOSED PAD 29
 76% PRINTED SOLDER COVERAGE BY AREA UNDER PACKAGE

4226146/A 08/2020

NOTES: (continued)

6. Laser cutting apertures with trapezoidal walls and rounded corners may offer better paste release. IPC-7525 may have alternate design recommendations.

重要なお知らせと免責事項

TI は、技術データと信頼性データ (データシートを含みます)、設計リソース (リファレンス デザインを含みます)、アプリケーションや設計に関する各種アドバイス、Web ツール、安全性情報、その他のリソースを、欠陥が存在する可能性のある「現状のまま」提供しており、商品性および特定目的に対する適合性の黙示保証、第三者の知的財産権の非侵害保証を含むいかなる保証も、明示的または黙示的にかかわらず拒否します。

これらのリソースは、TI 製品を使用する設計の経験を積んだ開発者への提供を意図したものです。(1) お客様のアプリケーションに適した TI 製品の選定、(2) お客様のアプリケーションの設計、検証、試験、(3) お客様のアプリケーションに該当する各種規格や、その他のあらゆる安全性、セキュリティ、規制、または他の要件への確実な適合に関する責任を、お客様のみが単独で負うものとし、

上記の各種リソースは、予告なく変更される可能性があります。これらのリソースは、リソースで説明されている TI 製品を使用するアプリケーションの開発の目的でのみ、TI はその使用をお客様に許諾します。これらのリソースに関して、他の目的で複製することや掲載することは禁止されています。TI や第三者の知的財産権のライセンスが付与されている訳ではありません。お客様は、これらのリソースを自身で使用した結果発生するあらゆる申し立て、損害、費用、損失、責任について、TI およびその代理人を完全に補償するものとし、TI は一切の責任を拒否します。

TI の製品は、[TI の販売条件](#)、[TI の総合的な品質ガイドライン](#)、[ti.com](#) または TI 製品などに関連して提供される他の適用条件に従い提供されます。TI がこれらのリソースを提供することは、適用される TI の保証または他の保証の放棄の拡大や変更を意味するものではありません。TI がカスタム、またはカスタマー仕様として明示的に指定していない限り、TI の製品は標準的なカタログに掲載される汎用機器です。

お客様がいかなる追加条項または代替条項を提案する場合も、TI はそれらに異議を唱え、拒否します。

Copyright © 2026, Texas Instruments Incorporated

最終更新日 : 2025 年 10 月