

# MUX36xxx 低容量、低リーク電流、36V高精度アナログ・マルチプレクサ

## 1 特長

- 小さいオン容量
  - MUX36S16: 13.5pF
  - MUX36D08: 8.7pF
- 少ない入力リーク電流: 1pA
- 少ない電荷注入: 0.31pC
- レール・ツー・レール動作
- 広い電源電圧範囲:  $\pm 5V \sim \pm 18V$ 、 $10V \sim 36V$
- 小さいオン抵抗: 125 $\Omega$
- 遷移時間: 97ns
- Break-Before-Make の切り替え動作
- EN ピンを  $V_{DD}$  に接続可能
- ロジック・レベル:  $2V \sim V_{DD}$
- 低い消費電流: 45 $\mu A$
- ESD 保護 (HBM): 2000V
- 業界標準の TSSOP/SOIC パッケージと、小型の WQFN パッケージのオプション

## 2 アプリケーション

- ファクトリ・オートメーションと産業用プロセス制御
- プログラマブル・ロジック・コントローラ (PLC)
- アナログ入力モジュール
- ATE 試験装置
- デジタル・マルチメータ
- バッテリ・モニタリング・システム

## 3 概要

MUX36S16およびMUX36D08 (MUX36xxx)は、最新のCMOS (相補型金属酸化膜半導体)高精度アナログ・マルチプレクサ(MUX)です。MUX36S16は16:1シングルエンド・チャンネル、MUX36D08は差動8:1またはデュアル8:1シングルエンド・チャンネルを提供します。MUX36S16およびMUX36D08は、デュアル電源( $\pm 5V \sim \pm 18V$ )でも単電源( $10V \sim 36V$ )でも正常に動作します。また、対称電源( $V_{DD} = 12V$ 、 $V_{SS} = -12V$ など)でも、非対称電源( $V_{DD} = 12V$ 、 $V_{SS} = -5V$ など)でも正常に動作します。すべてのデジタル入力は、TTL (トランジスタ・トランジスタ・ロジック)互換しきい値を備えており、有効電源電圧範囲内で動作するときTTLおよびCMOS両方のロジック互換性を提供します。

MUX36S16およびMUX36D08のオン/オフ・リーク電流は非常に低いため、入力インピーダンスの高い信号源からの信号を最小限の誤差でスイッチング可能です。45 $\mu A$ の低い消費電流により、低消費電力が重要なアプリケーションで使用できます。

### 製品情報<sup>(1)</sup>

型番	パッケージ	本体サイズ(公称)
MUX36S16	TSSOP (28)	9.70mm×6.40mm
	SOIC (28)	17.9mm×7.50mm
MUX36D08	WQFN (RTV) (32)	5.00mm×5.00mm
	WQFN (RSN) (32)	4.00mm×4.00mm

(1) 利用可能なすべてのパッケージについては、このデータシートの末尾にあるパッケージ・オプションについての付録を参照してください。

概略回路図

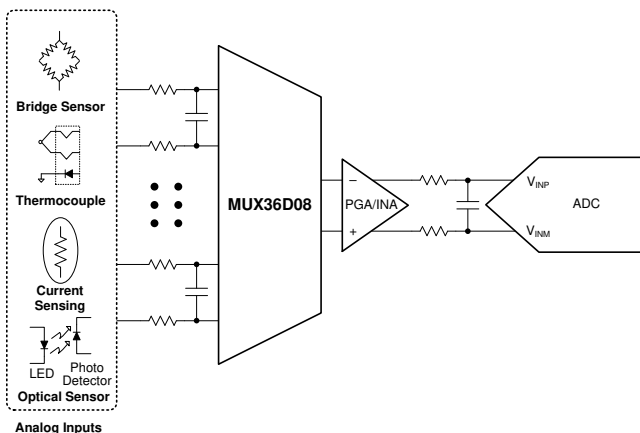

リーク電流と温度

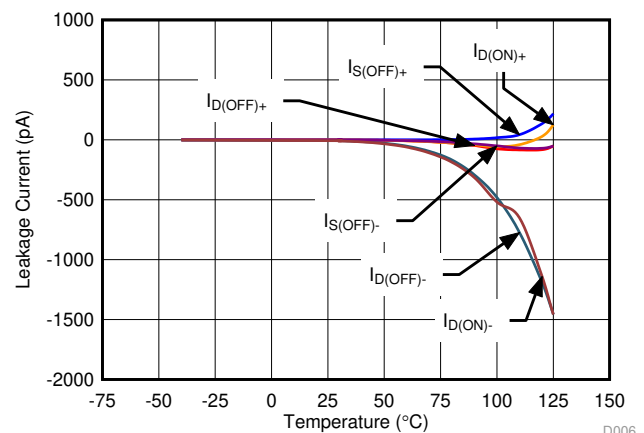

D006



## 目次

1	特長	1	8.3	Feature Description	26
2	アプリケーション	1	8.4	Device Functional Modes	28
3	概要	1	9	<b>Application and Implementation</b>	29
4	改訂履歴	2	9.1	Application Information	29
5	<b>Pin Configuration and Functions</b>	3	9.2	Typical Application	29
6	<b>Specifications</b>	7	10	<b>Power Supply Recommendations</b>	31
6.1	Absolute Maximum Ratings	7	11	<b>Layout</b>	32
6.2	ESD Ratings	7	11.1	Layout Guidelines	32
6.3	Recommended Operating Conditions	7	11.2	Layout Example	32
6.4	Thermal Information	8	12	デバイスおよびドキュメントのサポート	34
6.5	Electrical Characteristics: Dual Supply	8	12.1	ドキュメントのサポート	34
6.6	Electrical Characteristics: Single Supply	10	12.2	関連リンク	34
6.7	Typical Characteristics	12	12.3	ドキュメントの更新通知を受け取る方法	34
7	<b>Parameter Measurement Information</b>	17	12.4	コミュニティ・リソース	34
7.1	Truth Tables	17	12.5	商標	34
8	<b>Detailed Description</b>	25	12.6	静電気放電に関する注意事項	34
8.1	Overview	25	12.7	Glossary	34
8.2	Functional Block Diagram	25	13	メカニカル、パッケージ、および注文情報	34

## 4 改訂履歴

資料番号末尾の英字は改訂を表しています。その改訂履歴は英語版に準じています。

Revision B (April 2018) から Revision C に変更	Page
• Added BW, THD+N, and C <sub>IN</sub> rows to the <i>Electrical Characteristics: Dual Supply</i>	9
• Changed V <sub>DD</sub> and V <sub>SS</sub> supply current MAX values for ±15V supplies in <i>Electrical Characteristics: Dual Supply</i>	9
• Changed V <sub>DD</sub> and V <sub>SS</sub> supply current MAX values for 12V supplies in <i>Electrical Characteristics: Single Supply</i>	11

Revision A (November 2017) から Revision B に変更	Page
• 「特長」に WQFN パッケージ・オプションを追加	1
• 「製品情報」に WQFN パッケージ・オプションを追加	1
• Added pinout information for WQFN packages	3
• Added data for WQFN packages to <i>Thermal Information</i>	8

2016年11月発行のものから更新	Page
• 「特長」一覧で遷移時間を 85ns から 97ns (標準値) に変更	1
• 「特長」および「製品情報」に SOIC パッケージを追加	1
• Added the DW (SOIC) package to the <i>Pin Configuration and Functions</i> section	3
• Added SOIC package to the <i>Thermal Information</i> table	8
• Changed Transition time Typ value From 85: ns To: 97ns for ±15 V supplies in the <i>Electrical Characteristics: Dual Supply</i> table	9
• Added additional specifications for the SOIC packages (Q <sub>J</sub> , Off-isolation, and channel-to-channel crosstalk) for ±15 V supplies in <i>Electrical Characteristics: Dual Supply</i>	9
• Changed Transition time Typ value From: 91 To: 102 ns for 12 V supply in the <i>Electrical Characteristics: Single Supply</i> table	11
• Added additional specifications for the SOIC packages (Q <sub>J</sub> , Off-isolation, and channel-to-channel crosstalk) for 12 V supply in <i>Electrical Characteristics: Single Supply</i>	11

## 5 Pin Configuration and Functions

MUX36S16: DW and PW Package  
28-Pin SOIC and TSSOP  
Top View

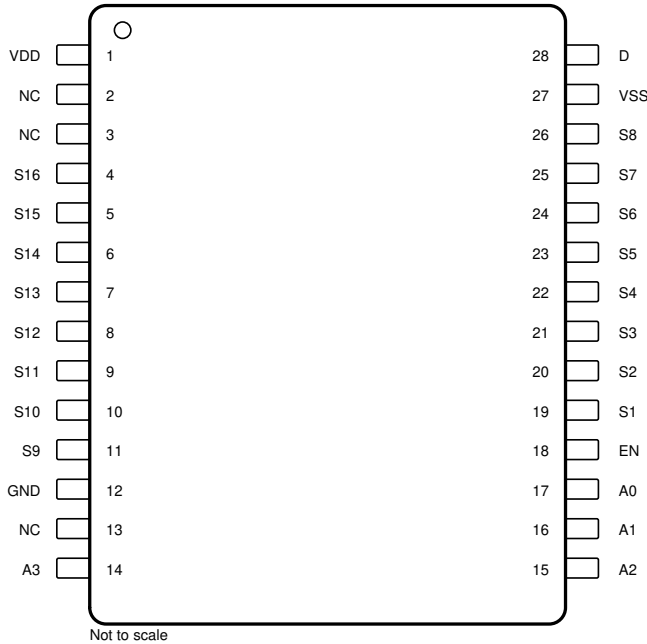

MUX36S16: RTV and RSN Package  
32-Pin WQFN  
Top View

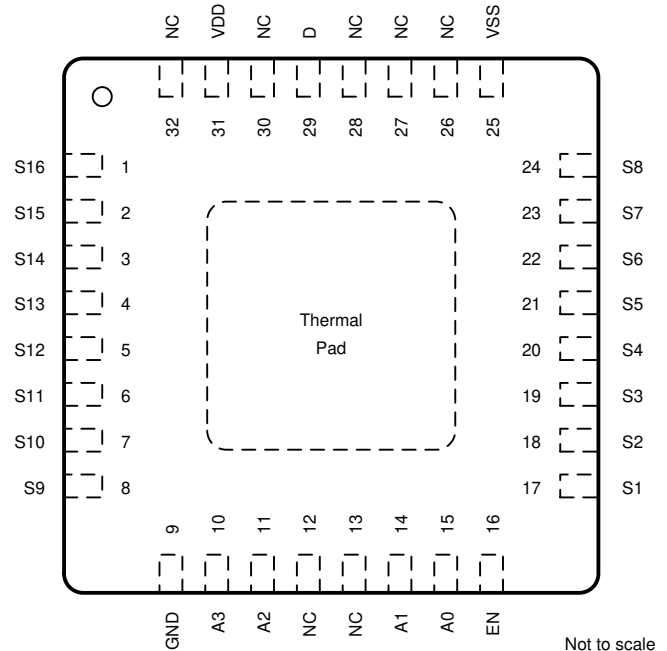

### Pin Functions, MUX36S16

PIN		FUNCTION	DESCRIPTION
NAME	TSSOP/ SOIC		
A0	17	15	Digital input Address line 0
A1	16	14	Digital input Address line 1
A2	15	11	Digital input Address line 2
A3	14	10	Digital input Address line 3
D	28	29	Analog input or output Drain pin. Can be an input or output.
EN	18	16	Digital input Active high digital input. When this pin is low, all switches are turned off. When this pin is high, the A[3:0] logic inputs determine which switch is turned on.
GND	12	9	Power supply Ground (0 V) reference
NC	2, 3, 13	12, 13, 26, 27, 28, 30, 32	No connect Do not connect
S1	19	17	Analog input or output Source pin 1. Can be an input or output.
S2	20	18	Analog input or output Source pin 2. Can be an input or output.
S3	21	19	Analog input or output Source pin 3. Can be an input or output.
S4	22	20	Analog input or output Source pin 4. Can be an input or output.
S5	23	21	Analog input or output Source pin 5. Can be an input or output.
S6	24	22	Analog input or output Source pin 6. Can be an input or output.
S7	25	23	Analog input or output Source pin 7. Can be an input or output.
S8	26	24	Analog input or output Source pin 8. Can be an input or output.
S9	11	8	Analog input or output Source pin 9. Can be an input or output.
S10	10	7	Analog input or output Source pin 10. Can be an input or output.

**Pin Functions, MUX36S16 (continued)**

PIN			FUNCTION	DESCRIPTION
NAME	TSSOP/ SOIC	WQFN		
S11	9	6	Analog input or output	Source pin 11. Can be an input or output.
S12	8	5	Analog input or output	Source pin 12. Can be an input or output.
S13	7	4	Analog input or output	Source pin 13. Can be an input or output.
S14	6	3	Analog input or output	Source pin 14. Can be an input or output.
S15	5	2	Analog input or output	Source pin 15. Can be an input or output.
S16	4	1	Analog input or output	Source pin 16. Can be an input or output.
VDD	1	31	Power supply	Positive power supply. This pin is the most positive power-supply potential. For reliable operation, connect a decoupling capacitor ranging from 0.1 $\mu$ F to 10 $\mu$ F between $V_{DD}$ and GND.
VSS	27	25	Power supply	Negative power supply. This pin is the most negative power-supply potential. In single-supply applications, this pin can be connected to ground. For reliable operation, connect a decoupling capacitor ranging from 0.1 $\mu$ F to 10 $\mu$ F between $V_{SS}$ and GND.

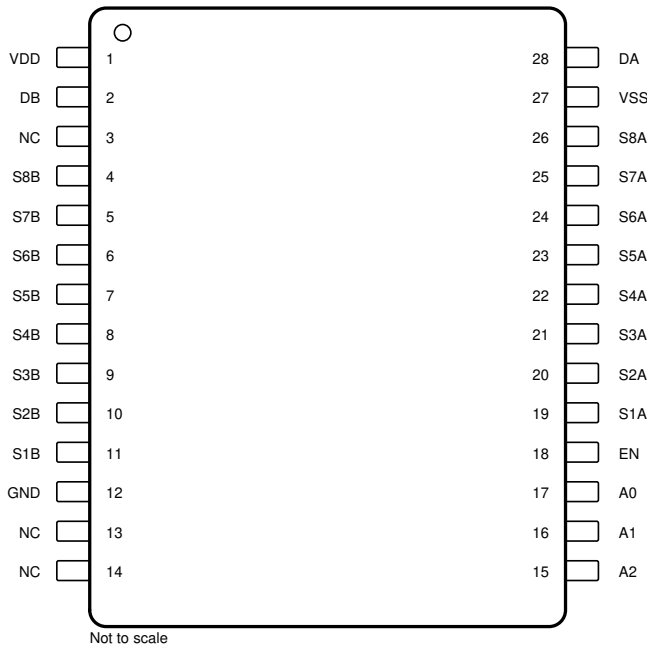
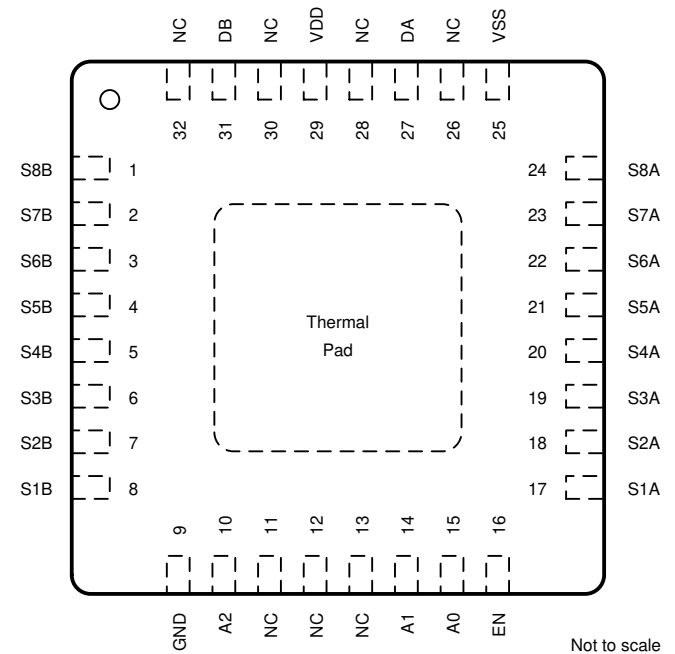
**MUX36D08: DW and PW Package  
28-Pin SOIC and TSSOP  
Top View**

**MUX36D08: RTV and RSN Package  
32-Pin WQFN  
Top View**

**Pin Functions: MUX36D08**

NAME	PIN		FUNCTION	DESCRIPTION
	TSSOP/ SOIC	WQFN		
A0	17	15	Digital input	Address line 0
A1	16	14	Digital input	Address line 1
A2	15	10	Digital input	Address line 2
DA	28	27	Analog input or output	Drain pin A. Can be an input or output.
DB	2	31	Analog input or output	Drain pin B. Can be an input or output.
EN	18	16	Digital input	Active high digital input. When this pin is low, all switches are turned off. When this pin is high, the A[2:0] logic inputs determine which pair of switches is turned on.
GND	12	9	Power supply	Ground (0 V) reference
NC	3, 13, 14	11, 12, 13, 26, 28, 30, 32	No connect	Do not connect
S1A	19	17	Analog input or output	Source pin 1A. Can be an input or output.
S2A	20	18	Analog input or output	Source pin 2A. Can be an input or output.
S3A	21	19	Analog input or output	Source pin 3A. Can be an input or output.
S4A	22	20	Analog input or output	Source pin 4A. Can be an input or output.
S5A	23	21	Analog input or output	Source pin 5A. Can be an input or output.
S6A	24	22	Analog input or output	Source pin 6A. Can be an input or output.
S7A	25	23	Analog input or output	Source pin 7A. Can be an input or output.
S8A	26	24	Analog input or output	Source pin 8A. Can be an input or output.
S1B	11	8	Analog input or output	Source pin 1B. Can be an input or output.
S2B	10	7	Analog input or output	Source pin 2B. Can be an input or output.
S3B	9	6	Analog input or output	Source pin 3B. Can be an input or output.

**Pin Functions: MUX36D08 (continued)**

PIN			FUNCTION	DESCRIPTION
NAME	TSSOP/ SOIC	WQFN		
S4B	8	5	Analog input or output	Source pin 4B. Can be an input or output.
S5B	7	4	Analog input or output	Source pin 5B. Can be an input or output.
S6B	6	3	Analog input or output	Source pin 6B. Can be an input or output.
S7B	5	2	Analog input or output	Source pin 7B. Can be an input or output.
S8B	4	1	Analog input or output	Source pin 8B. Can be an input or output.
VDD	1	29	Power supply	Positive power supply. This pin is the most positive power supply potential. For reliable operation, connect a decoupling capacitor ranging from 0.1 $\mu\text{F}$ to 10 $\mu\text{F}$ between $V_{DD}$ and GND.
VSS	27	25	Power supply	Negative power supply. This pin is the most negative power supply potential. In single-supply applications, this pin can be connected to ground. For reliable operation, connect a decoupling capacitor ranging from 0.1 $\mu\text{F}$ to 10 $\mu\text{F}$ between $V_{SS}$ and GND.

## 6 Specifications

### 6.1 Absolute Maximum Ratings

over operating free-air temperature range (unless otherwise noted)<sup>(1)</sup>

		MIN	MAX	UNIT	
Voltage	Supply	$V_{DD}$	-0.3	40	V
		$V_{SS}$	-40	0.3	
		$V_{DD} - V_{SS}$		40	
	Digital pins <sup>(2)</sup> : EN, A0, A1, A2, A3	$V_{SS} - 0.3$	$V_{DD} + 0.3$		
	Analog pins <sup>(2)</sup> : Sx, SxA, SxB, D, DA, DB	$V_{SS} - 2$	$V_{DD} + 2$		
Current <sup>(3)</sup>		-30	30	mA	
Temperature	Operating, $T_A$	-55	150	°C	
	Junction, $T_J$		150		
	Storage, $T_{stg}$	-65	150		

(1) Stresses beyond those listed under *Absolute Maximum Ratings* may cause permanent damage to the device. These are stress ratings only, which do not imply functional operation of the device at these or any other conditions beyond those indicated under *Recommended Operating Conditions*. Exposure to absolute-maximum-rated conditions for extended periods may affect device reliability.

(2) Voltage limits are valid if current is limited to  $\pm 30$  mA.

(3) Only one pin at a time.

### 6.2 ESD Ratings

		VALUE	UNIT	
$V_{(ESD)}$	Electrostatic discharge	Human-body model (HBM), per ANSI/ESDA/JEDEC JS-001 <sup>(1)</sup>	2000	V
		Charged-device model (CDM), per JEDEC specification JESD22-C101 <sup>(2)</sup>	500	

(1) JEDEC document JEP155 states that 500-V HBM allows safe manufacturing with a standard ESD control process.

(2) JEDEC document JEP157 states that 250-V CDM allows safe manufacturing with a standard ESD control process.

### 6.3 Recommended Operating Conditions

		MIN	NOM	MAX	UNIT
$V_{DD}$ <sup>(1)</sup>	Positive power-supply voltage	Dual supply	5	18	V
		Single supply	10	36	
$V_{SS}$ <sup>(2)</sup>	Negative power-supply voltage (dual supply)	-5		-18	V
$V_{DD} - V_{SS}$	Supply voltage	10		36	V
$V_S$	Source pins voltage <sup>(3)</sup>	$V_{SS}$		$V_{DD}$	V
$V_D$	Drain pins voltage	$V_{SS}$		$V_{DD}$	V
$V_{EN}$	Enable pin voltage	$V_{SS}$		$V_{DD}$	V
$V_A$	Address pins voltage	$V_{SS}$		$V_{DD}$	V
$I_{CH}$	Channel current ( $T_A = 25^\circ\text{C}$ )	-25		25	mA
$T_A$	Operating temperature	-40		125	°C

(1) When  $V_{SS} = 0$  V,  $V_{DD}$  can range from 10 V to 36 V.

(2)  $V_{DD}$  and  $V_{SS}$  can be any value as long as  $10 \text{ V} \leq (V_{DD} - V_{SS}) \leq 36 \text{ V}$ .

(3)  $V_S$  is the voltage on all the S pins.

## 6.4 Thermal Information

THERMAL METRIC <sup>(1)</sup>		MUX36S16/ MUX36D08				UNIT
		PW (TSSOP)	DW (SOIC)	RTV (WQFN)	RSN (WQFN)	
		28 PINS	28 PINS	32 PINS	32 PINS	
R <sub>θJA</sub>	Junction-to-ambient thermal resistance	79.8	53.6	33.0	33.7	°C/W
R <sub>θJC(top)</sub>	Junction-to-case (top) thermal resistance	24.0	30.1	20.8	26.5	°C/W
R <sub>θJB</sub>	Junction-to-board thermal resistance	37.6	28.5	13.9	13.4	°C/W
Ψ <sub>JT</sub>	Junction-to-top characterization parameter	1.2	9.0	0.3	0.3	°C/W
Ψ <sub>JB</sub>	Junction-to-board characterization parameter	37.1	28.4	13.8	13.4	°C/W
R <sub>θJC(bot)</sub>	Junction-to-case (bottom) thermal resistance	N/A	N/A	4.1	4.1	°C/W

(1) For more information about traditional and new thermal metrics, see the [Semiconductor and IC Package Thermal Metrics](#) application report.

## 6.5 Electrical Characteristics: Dual Supply

at T<sub>A</sub> = 25°C, V<sub>DD</sub> = 15 V, and V<sub>SS</sub> = -15 V (unless otherwise noted)

PARAMETER		TEST CONDITIONS		MIN	TYP	MAX	UNIT
<b>ANALOG SWITCH</b>							
Analog signal range		T <sub>A</sub> = -40°C to +125°C		V <sub>SS</sub>		V <sub>DD</sub>	V
R <sub>ON</sub>	On-resistance	V <sub>S</sub> = 0 V, I <sub>S</sub> = -1 mA			125	170	Ω
		V <sub>S</sub> = ±10 V, I <sub>S</sub> = -1 mA	T <sub>A</sub> = -40°C to +85°C		145	200	
			T <sub>A</sub> = -40°C to +125°C			230	
ΔR <sub>ON</sub>	On-resistance mismatch between channels	V <sub>S</sub> = ±10 V, I <sub>S</sub> = -1 mA			6	9	Ω
		T <sub>A</sub> = -40°C to +125°C				14	
R <sub>FLAT</sub>	On-resistance flatness	V <sub>S</sub> = 10 V, 0 V, -10 V			20	45	Ω
		T <sub>A</sub> = -40°C to +85°C				53	
		T <sub>A</sub> = -40°C to +125°C				58	
On-resistance drift		V <sub>S</sub> = 0 V			0.62		Ω/°C
I <sub>S(OFF)</sub>	Input leakage current	Switch state is off, V <sub>S</sub> = ±10 V, V <sub>D</sub> = ±10 V <sup>(1)</sup>		-0.04	0.001	0.04	nA
		T <sub>A</sub> = -40°C to +85°C		-0.15		0.15	
		T <sub>A</sub> = -40°C to +125°C		-1.2		1.2	
I <sub>D(OFF)</sub>	Output off-leakage current	Switch state is off, V <sub>S</sub> = ±10 V, V <sub>D</sub> = ±10 V <sup>(1)</sup>		-0.15	0.01	0.15	nA
		T <sub>A</sub> = -40°C to +85°C		-1		1	
		T <sub>A</sub> = -40°C to +125°C		-4.5		4.5	
I <sub>D(ON)</sub>	Output on-leakage current	Switch state is on, V <sub>D</sub> = ±10 V, V <sub>S</sub> = floating		-0.2	0.01	0.2	nA
		T <sub>A</sub> = -40°C to +85°C		-1		1	
		T <sub>A</sub> = -40°C to +125°C		-5.3		5.3	
I <sub>DL(ON)</sub>	Differential on-leakage current	Switch state is on, V <sub>DA</sub> = V <sub>DB</sub> = ±10 V, V <sub>S</sub> = floating		-15	3	15	pA
		T <sub>A</sub> = -40°C to +85°C		-100		100	
		T <sub>A</sub> = -40°C to +125°C		-500		500	
<b>LOGIC INPUT</b>							
V <sub>IH</sub>	Logic voltage high			2			V
V <sub>IL</sub>	Logic voltage low					0.8	V
I <sub>D</sub>	Input current					0.1	μA

(1) When V<sub>S</sub> is positive, V<sub>D</sub> is negative, and vice versa.

**Electrical Characteristics: Dual Supply (continued)**

at  $T_A = 25^\circ\text{C}$ ,  $V_{DD} = 15\text{ V}$ , and  $V_{SS} = -15\text{ V}$  (unless otherwise noted)

PARAMETER		TEST CONDITIONS		MIN	TYP	MAX	UNIT
<b>SWITCH DYNAMICS<sup>(2)</sup></b>							
$t_{ON}$	Enable turn-on time	$V_S = \pm 10\text{ V}$ , $R_L = 300\ \Omega$ , $C_L = 35\text{ pF}$	$T_A = -40^\circ\text{C to } +85^\circ\text{C}$		82	136	ns
			$T_A = -40^\circ\text{C to } +125^\circ\text{C}$			145	
						151	
$t_{OFF}$	Enable turn-off time	$V_S = \pm 10\text{ V}$ , $R_L = 300\ \Omega$ , $C_L = 35\text{ pF}$	$T_A = -40^\circ\text{C to } +85^\circ\text{C}$		63	78	ns
			$T_A = -40^\circ\text{C to } +125^\circ\text{C}$			89	
						97	
$t_t$	Transition time	$V_S = 10\text{ V}$ , $R_L = 300\ \Omega$ , $C_L = 35\text{ pF}$ ,	$T_A = -40^\circ\text{C to } +85^\circ\text{C}$		97	143	ns
			$T_A = -40^\circ\text{C to } +125^\circ\text{C}$			151	
						157	
$t_{BBM}$	Break-before-make time delay	$V_S = 10\text{ V}$ , $R_L = 300\ \Omega$ , $C_L = 35\text{ pF}$ , $T_A = -40^\circ\text{C to } +125^\circ\text{C}$		30	54		ns
$Q_J$	Charge injection	$C_L = 1\text{ nF}$ , $R_S = 0\ \Omega$	$V_S = 0\text{ V}$	TSSOP package	0.31		pC
				SOIC package	0.67		
			$V_S = -15\text{ V to } +15\text{ V}$	TSSOP package	$\pm 0.9$		
				SOIC package	$\pm 1.1$		
Off-isolation	$R_L = 50\ \Omega$ , $V_S = 1\text{ V}_{RMS}$ , $f = 1\text{ MHz}$	Nonadjacent channel to D, DA, DB	TSSOP package	-98		dB	
			SOIC package	-94			
			TSSOP package	-94			
			SOIC package	-88			
Channel-to-channel crosstalk	$R_L = 50\ \Omega$ , $V_S = 1\text{ V}_{RMS}$ , $f = 1\text{ MHz}$	Nonadjacent channels	TSSOP package	-100		dB	
			SOIC package	-96			
		Adjacent channels	TSSOP package	-88			
			SOIC package	-83			
BW	-3dB Bandwidth	$V_S = 1\text{ V}_{RMS}$ , $R_L = 50\ \Omega$ , $C_L = 5\text{ pF}$	MUX36S16		260		dB
			MUX36D08		430		
THD + N	Total harmonic distortion plus noise	$V_S = 0\text{ V or } V_{DD}$ , $R_L = 600\ \Omega$ , $C_L = 50\text{ pF}$ , $f = 20\text{ Hz to } 20\text{ kHz}$			0.09%		
$C_{IN}$	Digital input capacitance	$V_{IN} = 0\text{ V or } V_{DD}$			1.1		pF
$C_{S(OFF)}$	Input off-capacitance	$f = 1\text{ MHz}$ , $V_S = 0\text{ V}$			2.1	3	pF
$C_{D(OFF)}$	Output off-capacitance	$f = 1\text{ MHz}$ , $V_S = 0\text{ V}$	MUX36S16		11.1	12.2	pF
			MUX36D08		6.4	7.5	
$C_{S(ON)}$ , $C_{D(ON)}$	Output on-capacitance	$f = 1\text{ MHz}$ , $V_S = 0\text{ V}$	MUX36S16		13.5	15	pF
			MUX36D08		8.7	10.2	
<b>POWER SUPPLY</b>							
$V_{DD}$ supply current	All $V_A = 0\text{ V or } 3.3\text{ V}$ , $V_S = 0\text{ V}$ , $V_{EN} = 3.3\text{ V}$ ,		$T_A = -40^\circ\text{C to } +85^\circ\text{C}$		45	59	$\mu\text{A}$
			$T_A = -40^\circ\text{C to } +125^\circ\text{C}$			62	
						69	
$V_{SS}$ supply current	All $V_A = 0\text{ V or } 3.3\text{ V}$ , $V_S = 0\text{ V}$ , $V_{EN} = 3.3\text{ V}$ ,		$T_A = -40^\circ\text{C to } +85^\circ\text{C}$		26	33	$\mu\text{A}$
			$T_A = -40^\circ\text{C to } +125^\circ\text{C}$			36	
						43	

(2) Specified by design; not subject to production testing.

## 6.6 Electrical Characteristics: Single Supply

 at  $T_A = 25^\circ\text{C}$ ,  $V_{DD} = 12\text{ V}$ , and  $V_{SS} = 0\text{ V}$  (unless otherwise noted)

PARAMETER		TEST CONDITIONS		MIN	TYP	MAX	UNIT	
<b>ANALOG SWITCH</b>								
Analog signal range		$T_A = -40^\circ\text{C}$ to $+125^\circ\text{C}$		$V_{SS}$		$V_{DD}$	V	
$R_{ON}$	On-resistance	$V_S = 10\text{ V}$ , $I_S = -1\text{ mA}$		235	340		$\Omega$	
			$T_A = -40^\circ\text{C}$ to $+85^\circ\text{C}$			390		
			$T_A = -40^\circ\text{C}$ to $+125^\circ\text{C}$			430		
$\Delta R_{ON}$	On-resistance match	$V_S = 10\text{ V}$ , $I_S = -1\text{ mA}$		7	20		$\Omega$	
			$T_A = -40^\circ\text{C}$ to $+85^\circ\text{C}$			35		
			$T_A = -40^\circ\text{C}$ to $+125^\circ\text{C}$			40		
On-resistance drift		$V_S = 10\text{ V}$			1.07		$\Omega/^\circ\text{C}$	
$I_{S(OFF)}$	Input leakage current	Switch state is off, $V_S = 1\text{ V}$ and $V_D = 10\text{ V}$ , or $V_S = 10\text{ V}$ and $V_D = 1\text{ V}$ <sup>(1)</sup>		-0.04	0.001	0.04	nA	
			$T_A = -40^\circ\text{C}$ to $+85^\circ\text{C}$			0.15		
			$T_A = -40^\circ\text{C}$ to $+125^\circ\text{C}$			1.2		
$I_{D(OFF)}$	Output off leakage current	Switch state is off, $V_S = 1\text{ V}$ and $V_D = 10\text{ V}$ , or $V_S = 10\text{ V}$ and $V_D = 1\text{ V}$ <sup>(1)</sup>		-0.15	0.01	0.15	nA	
			$T_A = -40^\circ\text{C}$ to $+85^\circ\text{C}$			0.75		
			$T_A = -40^\circ\text{C}$ to $+125^\circ\text{C}$			2.4		
$I_{D(ON)}$	Output on leakage current	Switch state is on, $V_D = 1\text{ V}$ and $10\text{ V}$ , $V_S =$ floating		-0.15	0.01	0.15	nA	
			$T_A = -40^\circ\text{C}$ to $+85^\circ\text{C}$			0.75		
			$T_A = -40^\circ\text{C}$ to $+125^\circ\text{C}$			2.5		
$I_{DL(ON)}$	Differential on-leakage current	Switch state is on, $V_{DA} = V_{DB} = 1\text{ V}$ and $10\text{ V}$ , $V_S =$ floating		-15	3	15	pA	
			$T_A = -40^\circ\text{C}$ to $+85^\circ\text{C}$			100		
			$T_A = -40^\circ\text{C}$ to $+125^\circ\text{C}$			500		
<b>LOGIC INPUT</b>								
$V_{IH}$	Logic voltage high			2.0			V	
$V_{IL}$	Logic voltage low					0.8	V	
$I_D$	Input current					0.1	$\mu\text{A}$	

 (1) When  $V_S$  is 1 V,  $V_D$  is 10 V, and vice versa.

**Electrical Characteristics: Single Supply (continued)**

at  $T_A = 25^\circ\text{C}$ ,  $V_{DD} = 12\text{ V}$ , and  $V_{SS} = 0\text{ V}$  (unless otherwise noted)

PARAMETER		TEST CONDITIONS		MIN	TYP	MAX	UNIT
<b>SWITCH DYNAMIC CHARACTERISTICS<sup>(2)</sup></b>							
$t_{ON}$	Enable turn-on time	$V_S = 8\text{ V}$ , $R_L = 300\ \Omega$ , $C_L = 35\text{ pF}$			90	145	ns
			$T_A = -40^\circ\text{C}$ to $+85^\circ\text{C}$			145	
			$T_A = -40^\circ\text{C}$ to $+125^\circ\text{C}$			149	
$t_{OFF}$	Enable turn-off time	$V_S = 8\text{ V}$ , $R_L = 300\ \Omega$ , $C_L = 35\text{ pF}$			66	84	ns
			$T_A = -40^\circ\text{C}$ to $+85^\circ\text{C}$			94	
			$T_A = -40^\circ\text{C}$ to $+125^\circ\text{C}$			102	
$t_t$	Transition time	$V_S = 8\text{ V}$ , $C_L = 35\text{ pF}$			107	147	ns
		$V_S = 8\text{ V}$ , $R_L = 300\ \Omega$ , $C_L = 35\text{ pF}$ ,	$T_A = -40^\circ\text{C}$ to $+85^\circ\text{C}$			153	
		$V_S = 8\text{ V}$ , $R_L = 300\ \Omega$ , $C_L = 35\text{ pF}$ ,	$T_A = -40^\circ\text{C}$ to $+125^\circ\text{C}$			155	
$t_{BBM}$	Break-before-make time delay	$V_S = 8\text{ V}$ , $R_L = 300\ \Omega$ , $C_L = 35\text{ pF}$ , $T_A = -40^\circ\text{C}$ to $+125^\circ\text{C}$		30	54		ns
$Q_J$	Charge injection	$C_L = 1\text{ nF}$ , $R_S = 0\ \Omega$	$V_S = 6\text{ V}$	TSSOP package	0.12		pC
				SOIC package	0.38		
			$V_S = 0\text{ V}$ to $12\text{ V}$	TSSOP	$\pm 0.17$		
				SOIC package	$\pm 0.48$		
Off-isolation	$R_L = 50\ \Omega$ , $V_S = 1\text{ V}_{RMS}$ , $f = 1\text{ MHz}$	Nonadjacent channel to D, DA, DB	TSSOP package	-97		dB	
			SOIC package	-94			
		Adjacent channel to D, DA, DB	TSSOP package	-94			
			SOIC package	-88			
Channel-to-channel crosstalk	$R_L = 50\ \Omega$ , $V_S = 1\text{ V}_{RMS}$ , $f = 1\text{ MHz}$	Nonadjacent channels	TSSOP package	-100		dB	
			SOIC package	-99			
		Adjacent channels	TSSOP	-88			
			SOIC package	-83			
$C_{S(OFF)}$	Input off-capacitance	$f = 1\text{ MHz}$ , $V_S = 6\text{ V}$			2.4	3.4	pF
$C_{D(OFF)}$	Output off-capacitance	$f = 1\text{ MHz}$ , $V_S = 6\text{ V}$	MUX36S16		14	15.4	pF
			MUX36D08		7.8	9.1	
$C_{S(ON)}$ , $C_{D(ON)}$	Output on-capacitance	$f = 1\text{ MHz}$ , $V_S = 6\text{ V}$	MUX36S16		16.2	18	pF
			MUX36D08		9.9	11.6	
<b>POWER SUPPLY</b>							
$V_{DD}$ supply current	All $V_A = 0\text{ V}$ or $3.3\text{ V}$ , $V_S = 0\text{ V}$ , $V_{EN} = 3.3\text{ V}$				41	59	$\mu\text{A}$
		$T_A = -40^\circ\text{C}$ to $+85^\circ\text{C}$				56	
		$T_A = -40^\circ\text{C}$ to $+125^\circ\text{C}$				62	
$V_{SS}$ supply current	All $V_A = 0\text{ V}$ or $3.3\text{ V}$ , $V_S = 0\text{ V}$ , $V_{EN} = 3.3\text{ V}$				22	29	$\mu\text{A}$
		$T_A = -40^\circ\text{C}$ to $+85^\circ\text{C}$				31	
		$T_A = -40^\circ\text{C}$ to $+125^\circ\text{C}$				37	

(2) Specified by design, not subject to production test.

### 6.7 Typical Characteristics

at  $T_A = 25^\circ\text{C}$ ,  $V_{DD} = 15\text{ V}$ , and  $V_{SS} = -15\text{ V}$  (unless otherwise noted)



图 1. On-Resistance vs Source or Drain Voltage



图 2. On-Resistance vs Source or Drain Voltage

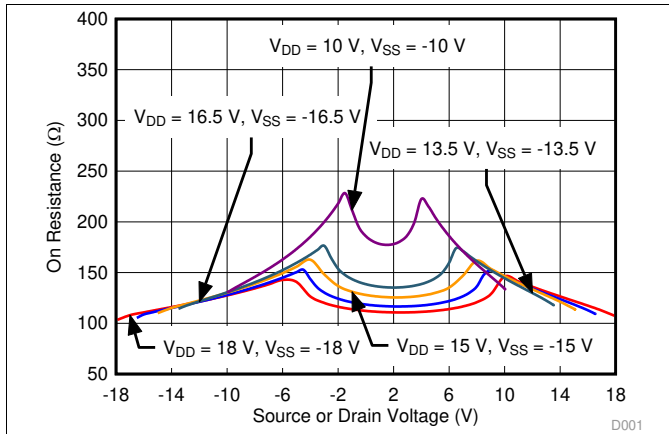

图 3. On-Resistance vs Source or Drain Voltage

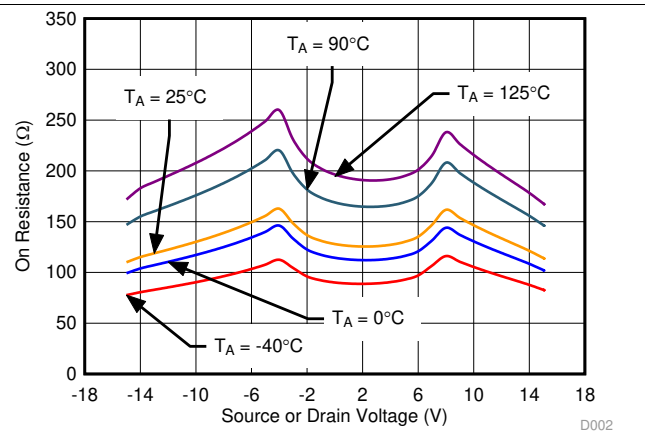

图 4. On-Resistance vs Source or Drain Voltage

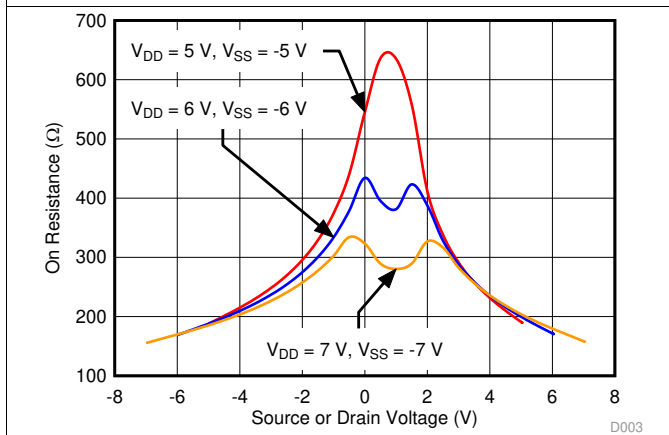

图 5. On-Resistance vs Source or Drain Voltage

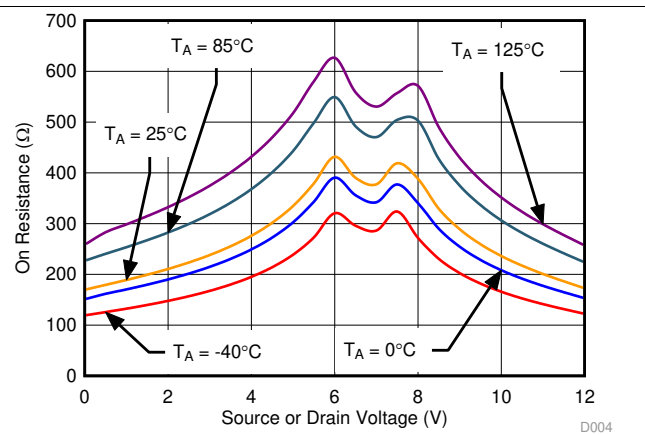

图 6. On-Resistance vs Source or Drain Voltage

**Typical Characteristics (continued)**

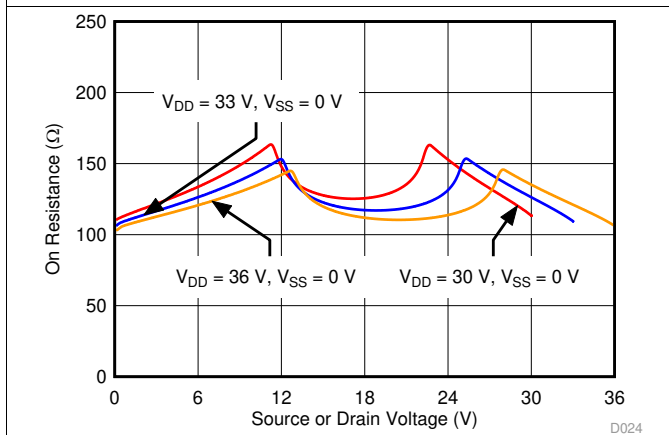
at  $T_A = 25^\circ\text{C}$ ,  $V_{DD} = 15\text{ V}$ , and  $V_{SS} = -15\text{ V}$  (unless otherwise noted)

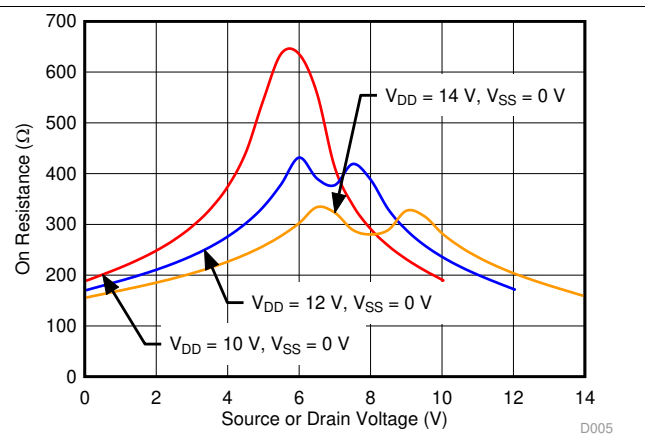
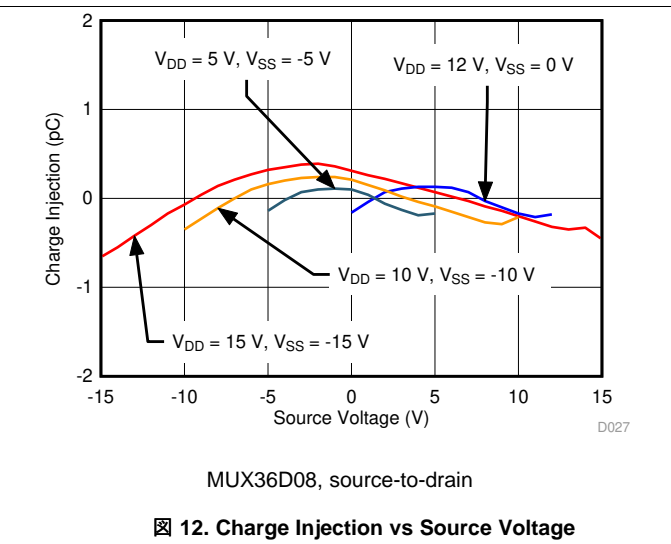
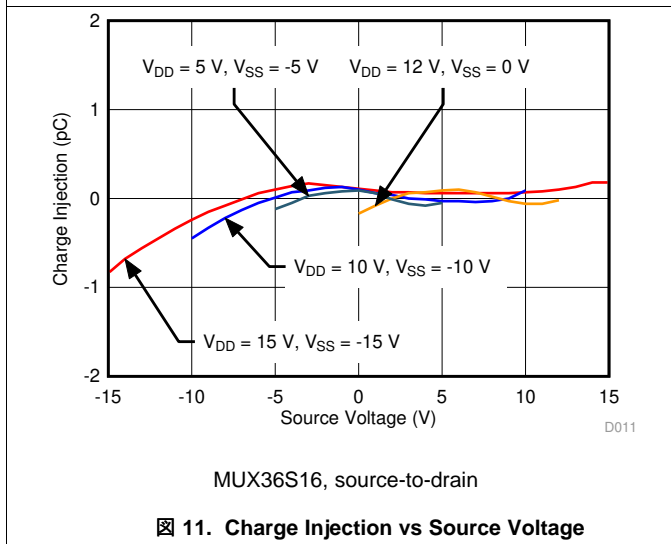
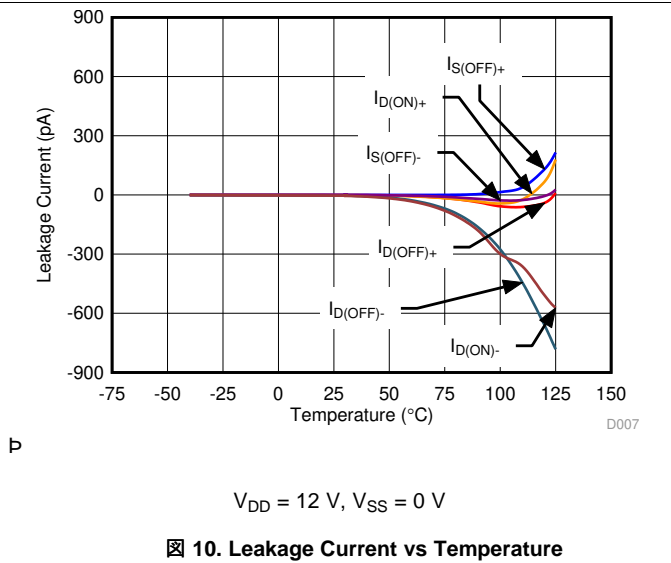
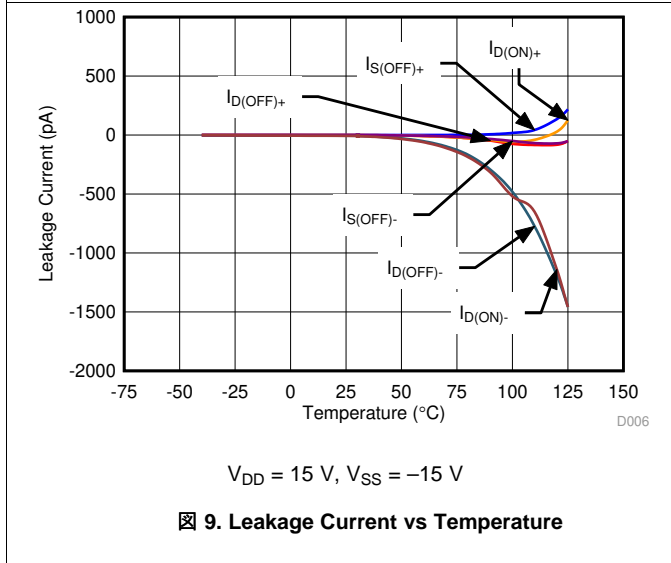
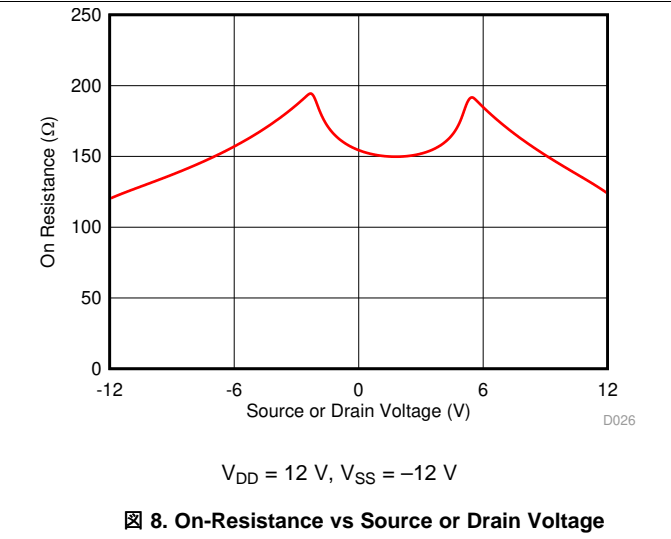
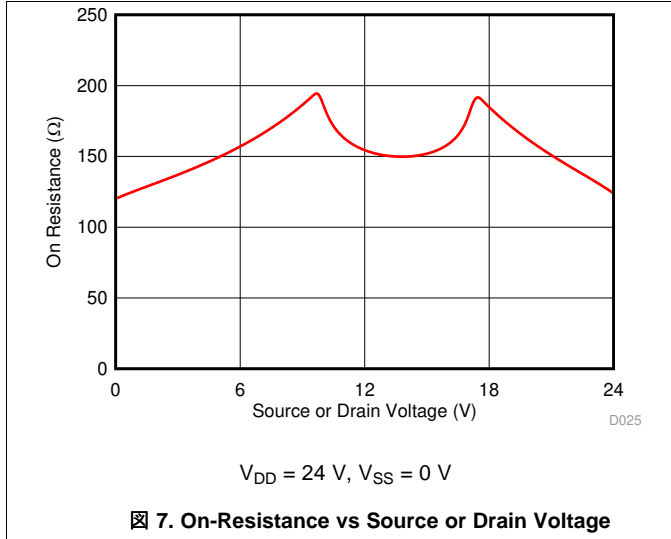

**Typical Characteristics (continued)**

at  $T_A = 25^\circ\text{C}$ ,  $V_{DD} = 15\text{ V}$ , and  $V_{SS} = -15\text{ V}$  (unless otherwise noted)

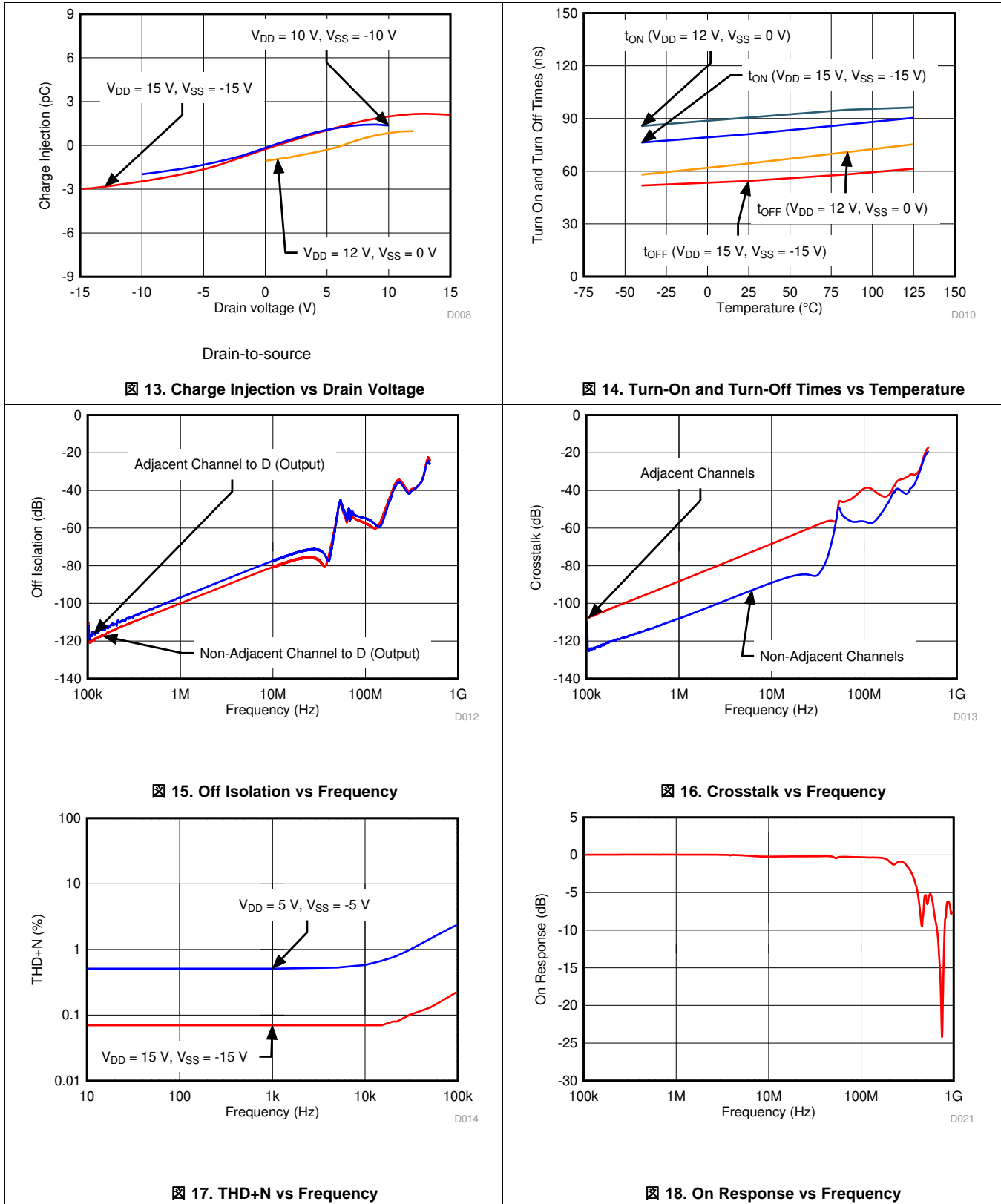

Typical Characteristics (continued)

at  $T_A = 25^\circ\text{C}$ ,  $V_{DD} = 15\text{ V}$ , and  $V_{SS} = -15\text{ V}$  (unless otherwise noted)

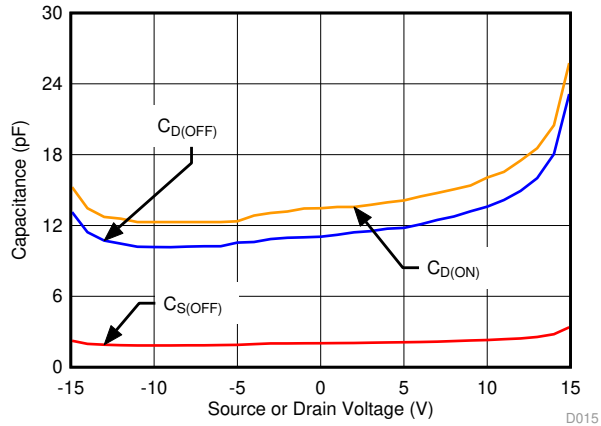

MUX36S16,  $V_{DD} = 15\text{ V}$ ,  $V_{SS} = -15\text{ V}$

19. Capacitance vs Source Voltage

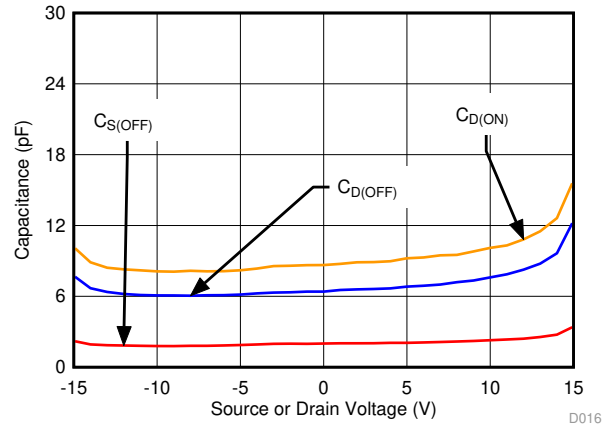

MUX36D08,  $V_{DD} = 15\text{ V}$ ,  $V_{SS} = -15\text{ V}$

20. Capacitance vs Source Voltage

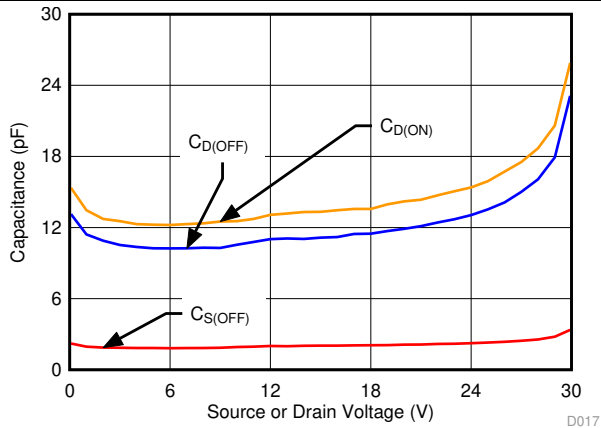

MUX36S16,  $V_{DD} = 30\text{ V}$ ,  $V_{SS} = 0\text{ V}$

21. Capacitance vs Source Voltage

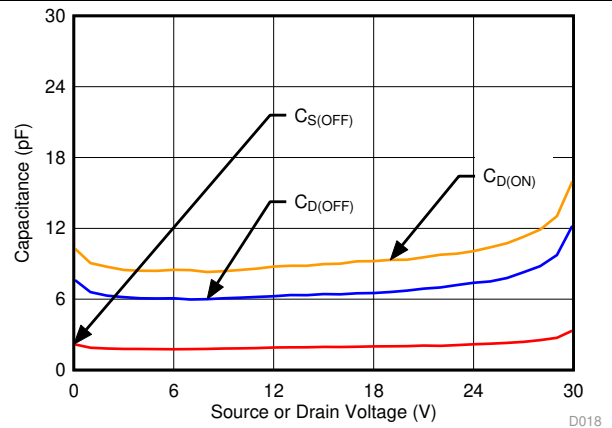

MUX36D08,  $V_{DD} = 30\text{ V}$ ,  $V_{SS} = 0\text{ V}$

22. Capacitance vs Source Voltage

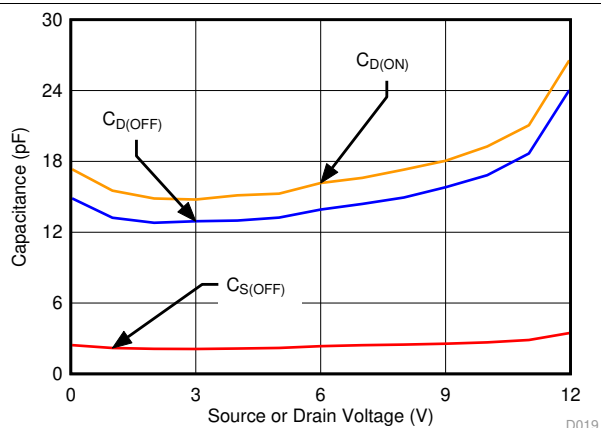

MUX36S16,  $V_{DD} = 12\text{ V}$ ,  $V_{SS} = 0\text{ V}$

23. Capacitance vs Source Voltage

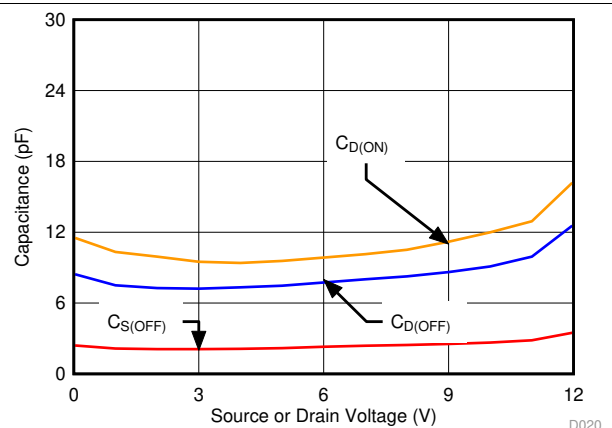

MUX36D08,  $V_{DD} = 12\text{ V}$ ,  $V_{SS} = 0\text{ V}$

24. Capacitance vs Source Voltage

**Typical Characteristics (continued)**

at  $T_A = 25^\circ\text{C}$ ,  $V_{DD} = 15\text{ V}$ , and  $V_{SS} = -15\text{ V}$  (unless otherwise noted)

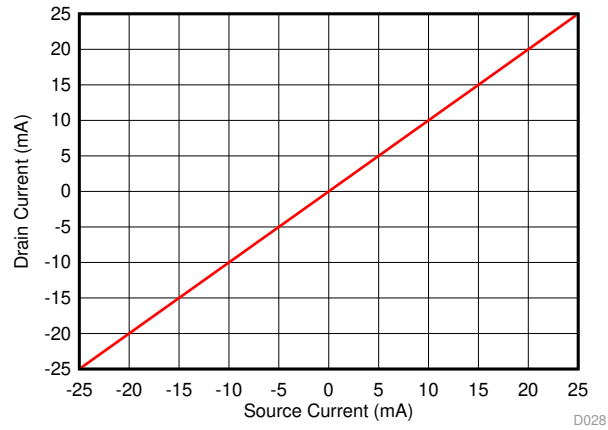

⊠ 25. Source Current vs Drain Current

## 7 Parameter Measurement Information

### 7.1 Truth Tables

**表 1. MUX36S16**

EN	A3	A2	A1	A0	ON-CHANNEL
0	X <sup>(1)</sup>	X <sup>(1)</sup>	X <sup>(1)</sup>	X <sup>(1)</sup>	All channels are off
1	0	0	0	0	Channel 1
1	0	0	0	1	Channel 2
1	0	0	1	0	Channel 3
1	0	0	1	1	Channel 4
1	0	1	0	0	Channel 5
1	0	1	0	1	Channel 6
1	0	1	1	0	Channel 7
1	0	1	1	1	Channel 8
1	1	0	0	0	Channel 9
1	1	0	0	1	Channel 10
1	1	0	1	0	Channel 11
1	1	0	1	1	Channel 12
1	1	1	0	0	Channel 13
1	1	1	0	1	Channel 14
1	1	1	1	0	Channel 15
1	1	1	1	1	Channel 16

(1) X denotes *don't care*.

**表 2. MUX36D08**

EN	A2	A1	A0	ON-CHANNEL
0	X <sup>(1)</sup>	X <sup>(1)</sup>	X <sup>(1)</sup>	All channels are off
1	0	0	0	Channels 1A and 1B
1	0	0	1	Channels 2A and 2B
1	0	1	0	Channels 3A and 3B
1	0	1	1	Channels 4A and 4B
1	1	0	0	Channels 5A and 5B
1	1	0	1	Channels 6A and 6B
1	1	1	0	Channels 7A and 7B
1	1	1	1	Channels 8A and 8B

(1) X denotes *don't care*.

### 7.1.1 On-Resistance

The on-resistance of the MUX36xxx is the ohmic resistance across the source (Sx, SxA, or SxB) and drain (D, DA, or DB) pins of the device. The on-resistance varies with input voltage and supply voltage. The symbol  $R_{ON}$  is used to denote on-resistance. The measurement setup used to measure  $R_{ON}$  is shown in [Figure 26](#). Voltage (V) and current ( $I_{CH}$ ) are measured using this setup, and  $R_{ON}$  is computed as shown in [Equation 1](#):

$$R_{ON} = V / I_{CH} \tag{1}$$

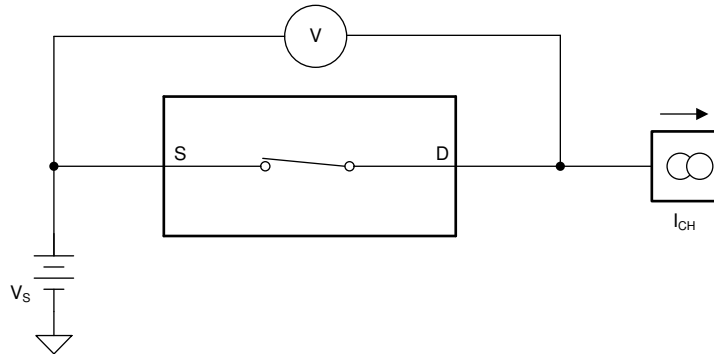

**Figure 26. On-Resistance Measurement Setup**

### 7.1.2 Off Leakage

There are two types of leakage currents associated with a switch during the OFF state:

1. Source off-leakage current
2. Drain off-leakage current

Source leakage current is defined as the leakage current flowing into or out of the source pin when the switch is off. This current is denoted by the symbol  $I_{S(OFF)}$ .

Drain leakage current is defined as the leakage current flowing into or out of the drain pin when the switch is off. This current is denoted by the symbol  $I_{D(OFF)}$ .

The setup used to measure both off-leakage currents is shown in [Figure 27](#).

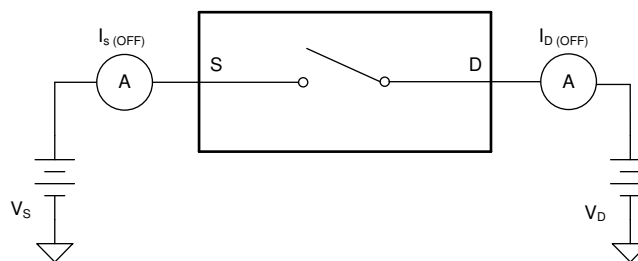

**Figure 27. Off-Leakage Measurement Setup**

### 7.1.3 On-Leakage Current

On-leakage current is defined as the leakage current that flows into or out of the drain pin when the switch is in the ON state. The source pin is left floating during the measurement. [Figure 28](#) shows the circuit used for measuring the on-leakage current, denoted by  $I_{D(ON)}$ .

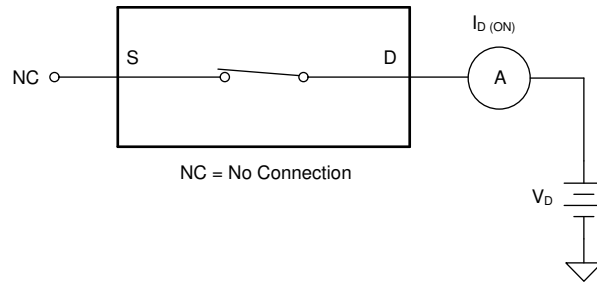

**Figure 28. On-Leakage Measurement Setup**

### 7.1.4 Differential On-Leakage Current

In case of a differential signal, the on-leakage current is defined as the differential leakage current that flows into, or out of, the drain pins when the switches are in the ON state. The source pins are left floating during the measurement. [Figure 29](#) shows the circuit used for measuring the on-leakage current on each signal path, denoted by  $I_{DA(ON)}$  and  $I_{DB(ON)}$ . The absolute difference between these two currents is defined as the differential on-leakage current, denoted by  $I_{DL(ON)}$ .

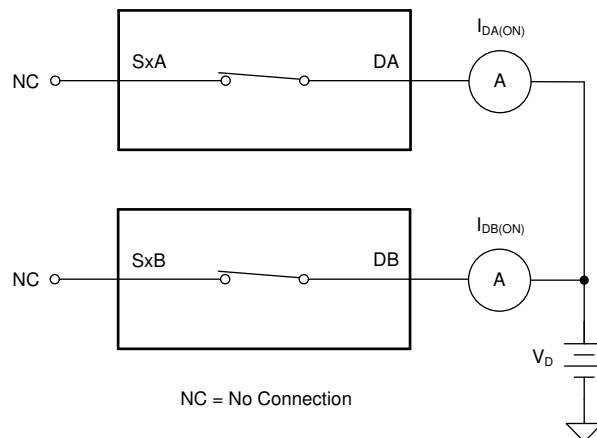

**Figure 29. Differential On-Leakage Measurement Setup**

### 7.1.5 Transition Time

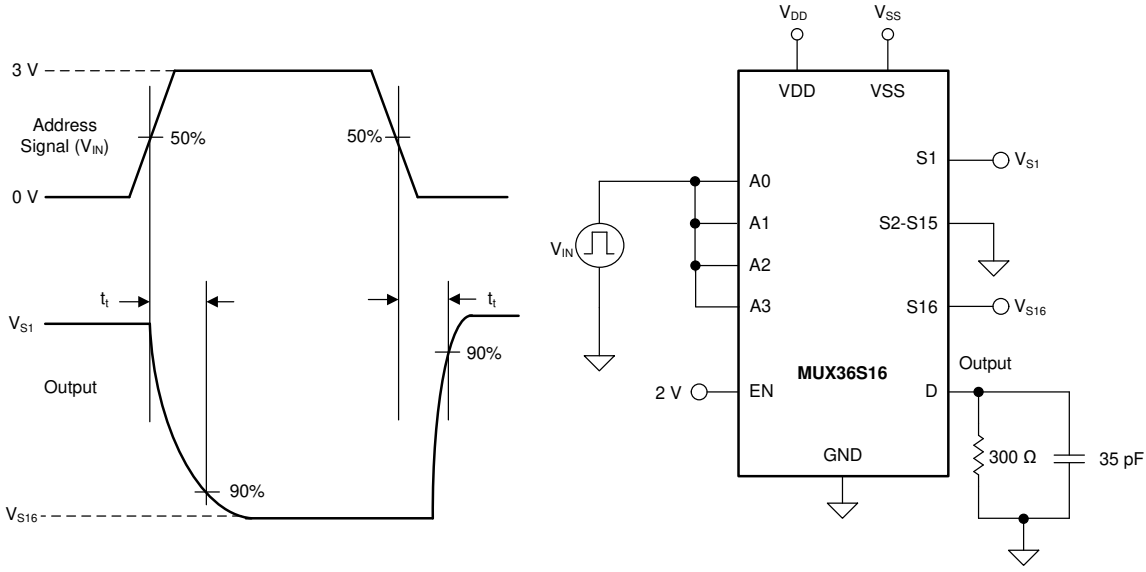
Transition time is defined as the time taken by the output of the MUX36xxx to rise or fall to 90% of the transition after the digital address signal has fallen or risen to 50% of the transition.  30 shows the setup used to measure transition time, denoted by the symbol  $t_t$ .

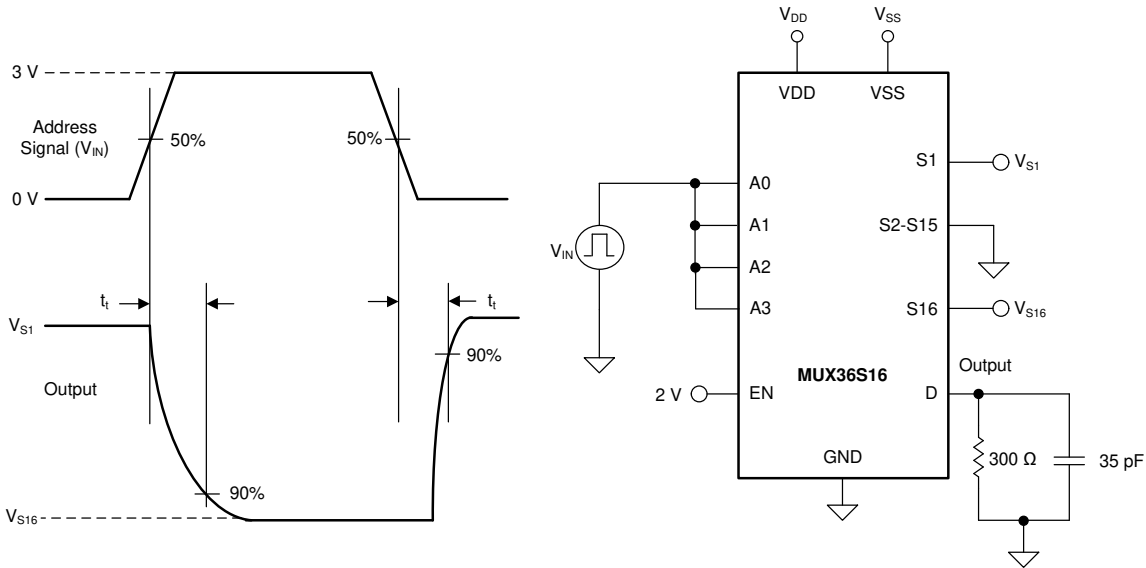

 **30. Transition-Time Measurement Setup**

### 7.1.6 Break-Before-Make Delay

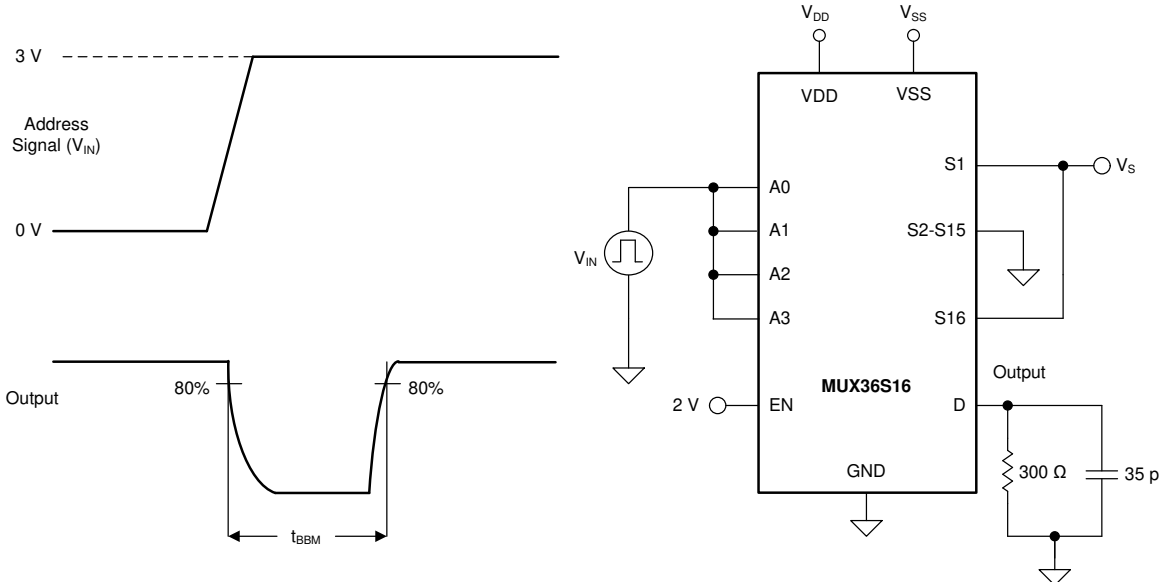
Break-before-make delay is a safety feature that prevents two inputs from connecting when the MUX36xxx is switching. The MUX36xxx output first breaks from the ON-state switch before making the connection with the next ON-state switch. The time delay between the *break* and the *make* is known as break-before-make delay.  31 shows the setup used to measure break-before-make delay, denoted by the symbol  $t_{BBM}$ .

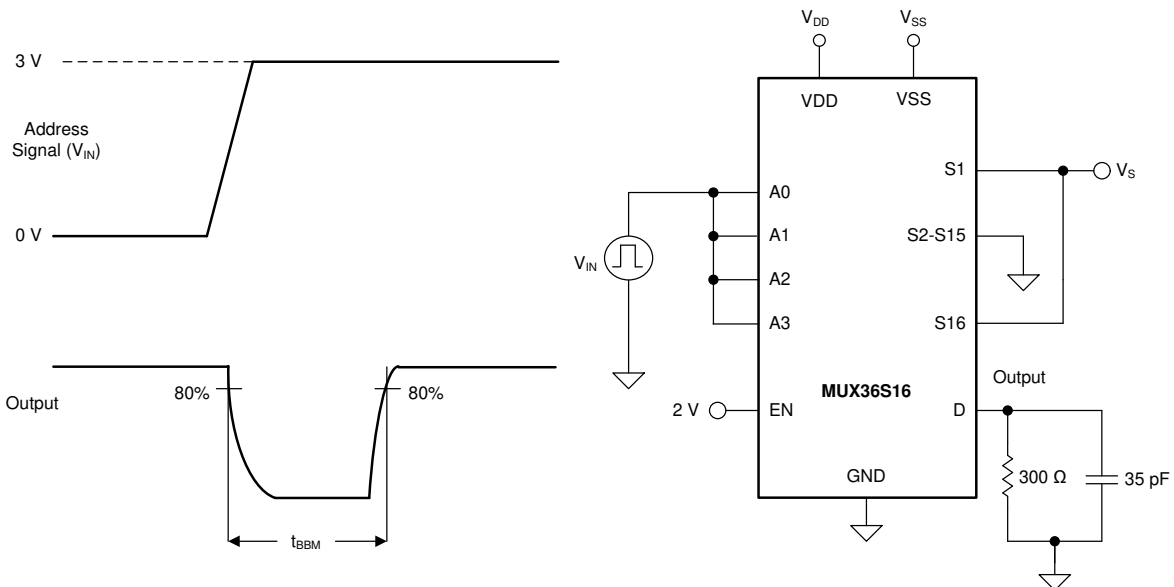

 **31. Break-Before-Make Delay Measurement Setup**

### 7.1.7 Turn-On and Turn-Off Time

Turn-on time is defined as the time taken by the output of the MUX36xxx to rise to 90% final value after the enable signal has risen to 50% final value.  32 shows the setup used to measure turn-on time. Turn-on time is denoted by the symbol  $t_{ON}$ .

Turn off time is defined as the time taken by the output of the MUX36xxx to fall to 10% initial value after the enable signal has fallen to 50% initial value.  32 shows the setup used to measure turn-off time. Turn-off time is denoted by the symbol  $t_{OFF}$ .

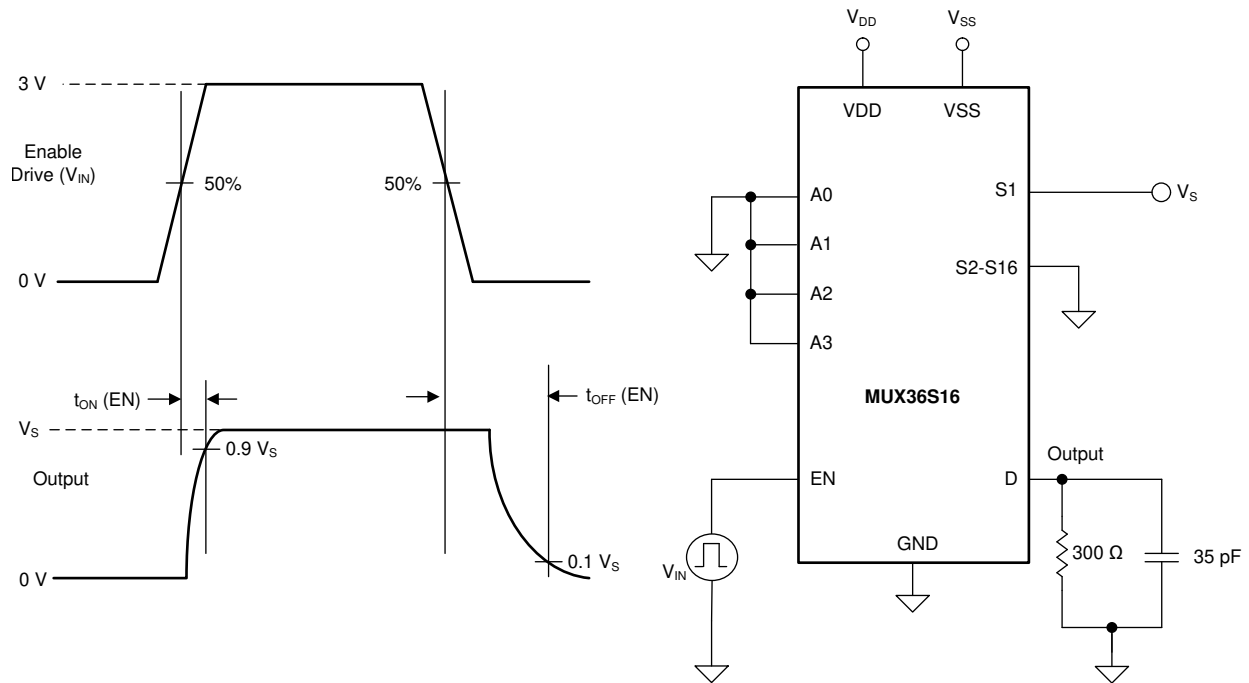

 32. Turn-On and Turn-Off Time Measurement Setup

### 7.1.8 Charge Injection

The MUX36xxx have a simple transmission-gate topology. Any mismatch in capacitance between the NMOS and PMOS transistors results in a charge injected into the source or drain of the device. The amount of charge injected into the source or drain of the device is known as charge injection, and is denoted by the symbol  $Q_{INJ}$ . [Figure 33](#) shows the setup used to measure charge injection.

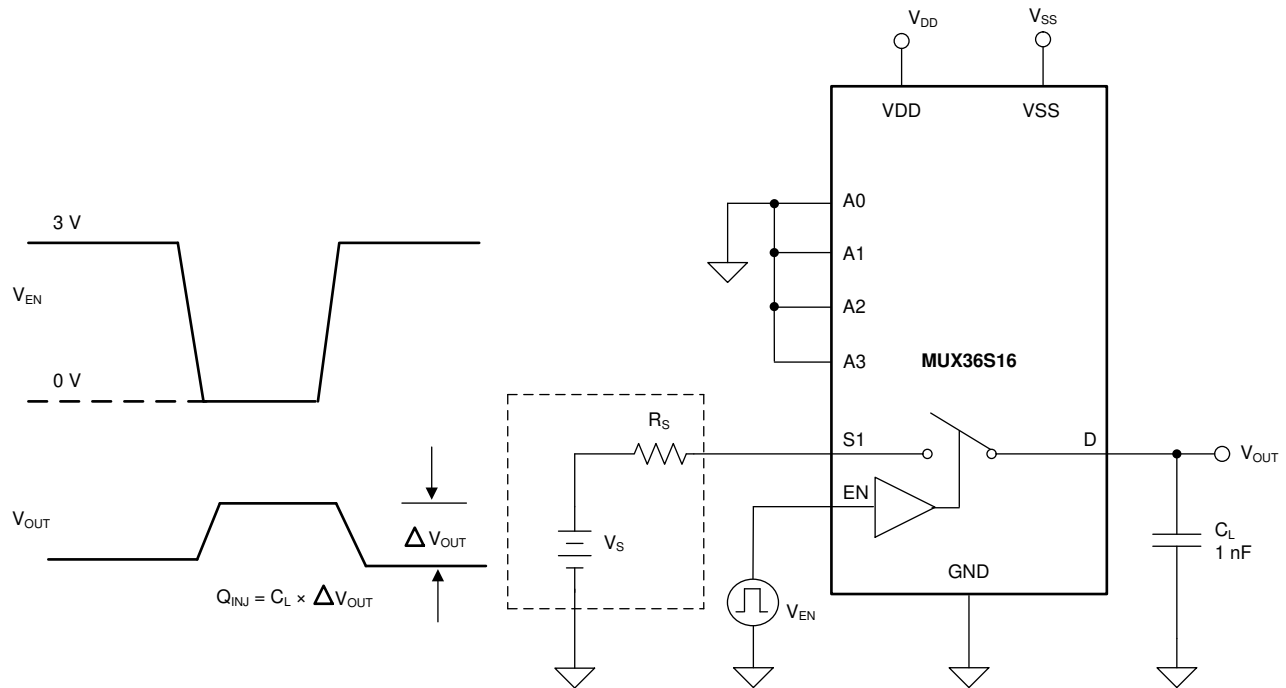

**Figure 33. Charge-Injection Measurement Setup**

### 7.1.9 Off Isolation

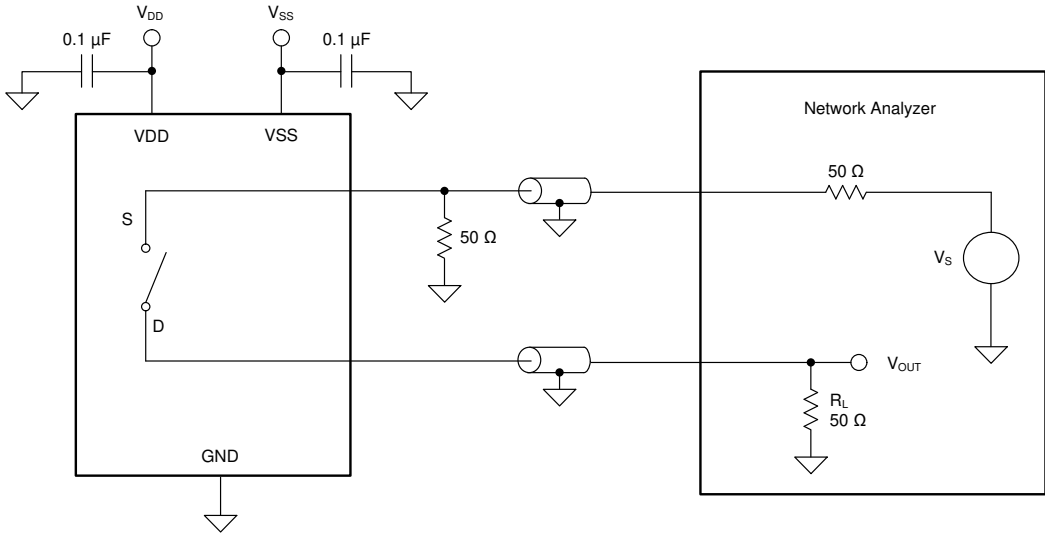
Off isolation is defined as the voltage at the drain pin (D, DA, or DB) of the MUX36xxx when a 1- $V_{RMS}$  signal is applied to the source pin ( $S_x$ ,  $S_{xA}$ , or  $S_{xB}$ ) of an off-channel.  shows the setup used to measure off isolation. Use [式 2](#) to compute off isolation.

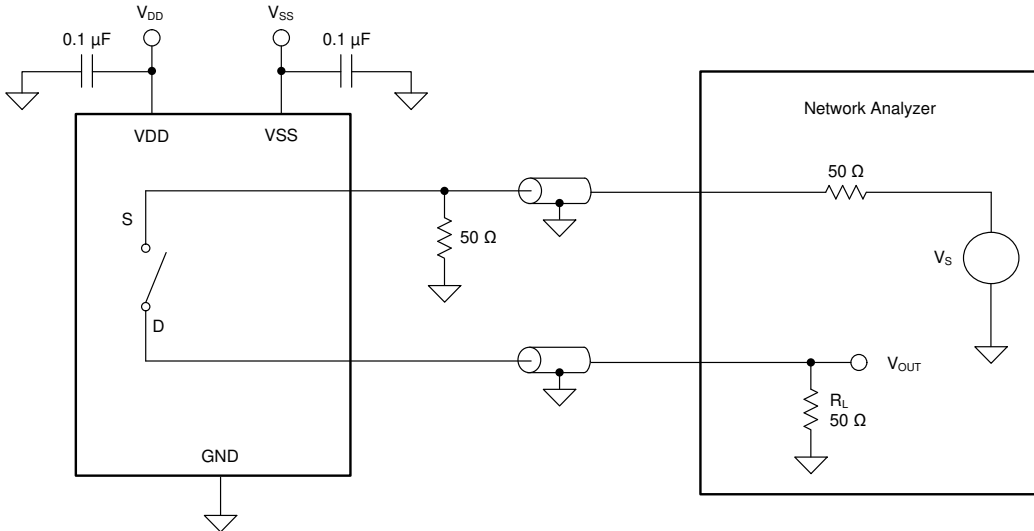

 **34. Off Isolation Measurement Setup**

$$\text{Off Isolation} = 20 \cdot \text{Log} \left( \frac{V_{OUT}}{V_S} \right) \tag{2}$$

### 7.1.10 Channel-to-Channel Crosstalk

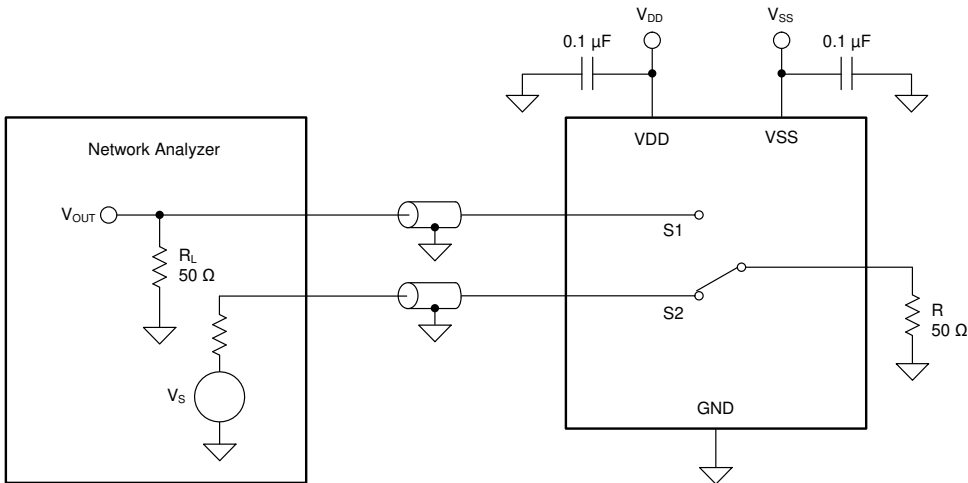
Channel-to-channel crosstalk is defined as the voltage at the source pin ( $S_x$ ,  $S_{xA}$ , or  $S_{xB}$ ) of an off-channel, when a 1- $V_{RMS}$  signal is applied at the source pin of an on-channel.  shows the setup used to measure channel-to-channel crosstalk. Use [式 3](#) to compute, channel-to-channel crosstalk.

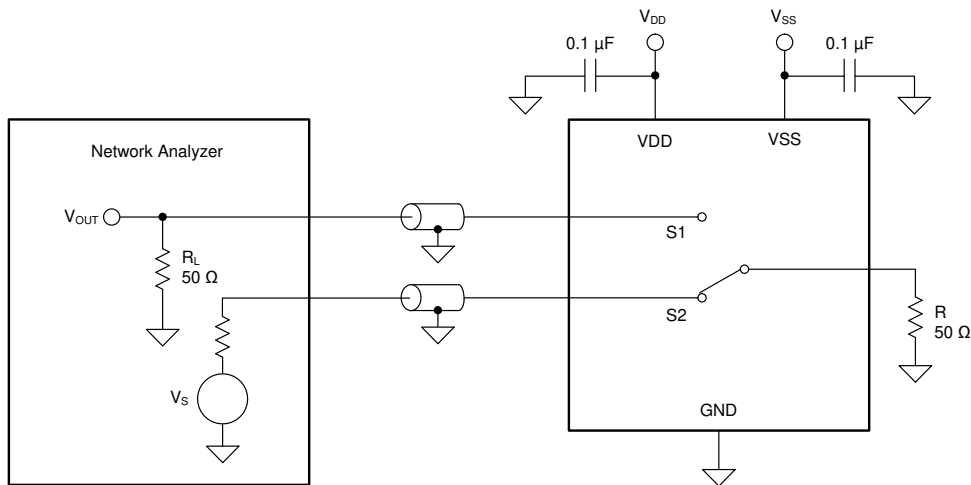

 **35. Channel-to-Channel Crosstalk Measurement Setup**

$$\text{Channel-to-Channel Crosstalk} = 20 \cdot \text{Log} \left( \frac{V_{OUT}}{V_S} \right) \tag{3}$$

### 7.1.11 Bandwidth

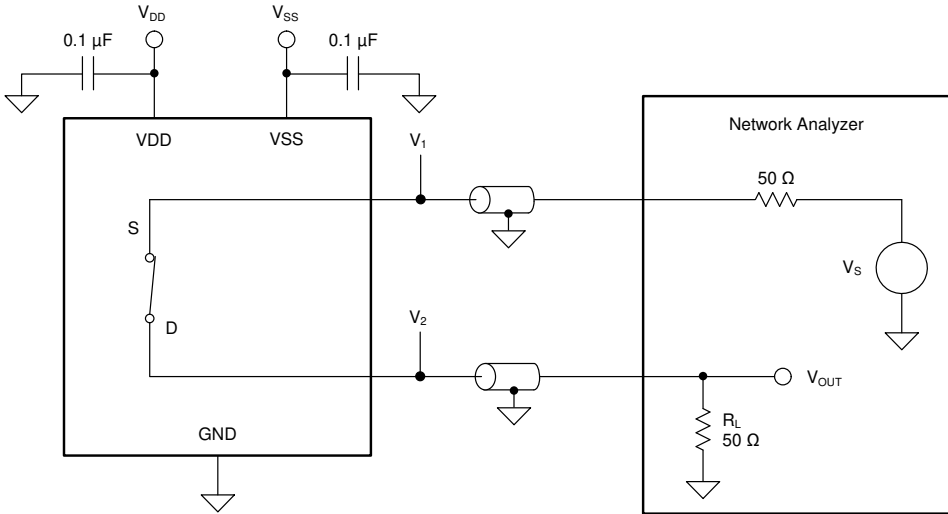
Bandwidth is defined as the range of frequencies that are attenuated by less than 3 dB when the input is applied to the source pin of an on-channel, and the output measured at the drain pin of the MUX36xxx.  shows the setup used to measure bandwidth of the mux. Use [Equation 4](#) to compute the attenuation.

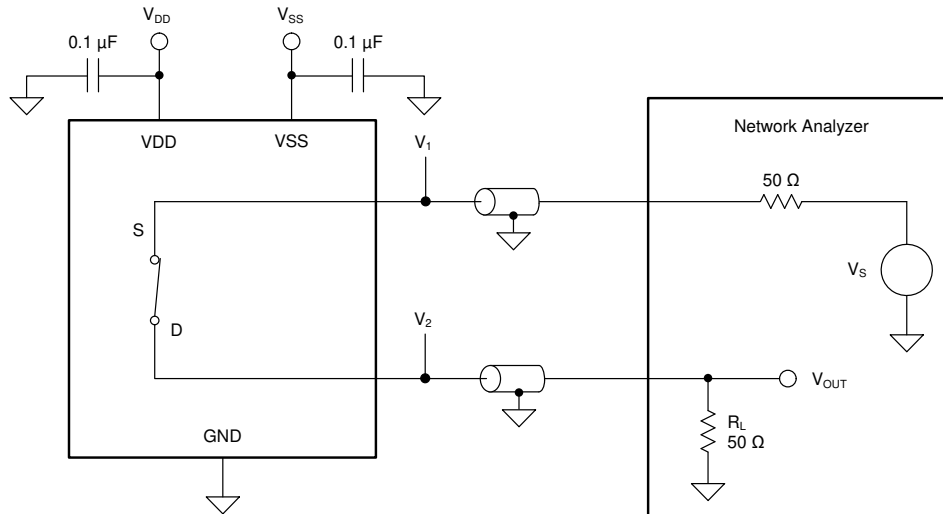

 **36. Bandwidth Measurement Setup**

$$\text{Attenuation} = 20 \cdot \text{Log} \left( \frac{V_2}{V_1} \right)$$

(4)

### 7.1.12 THD + Noise

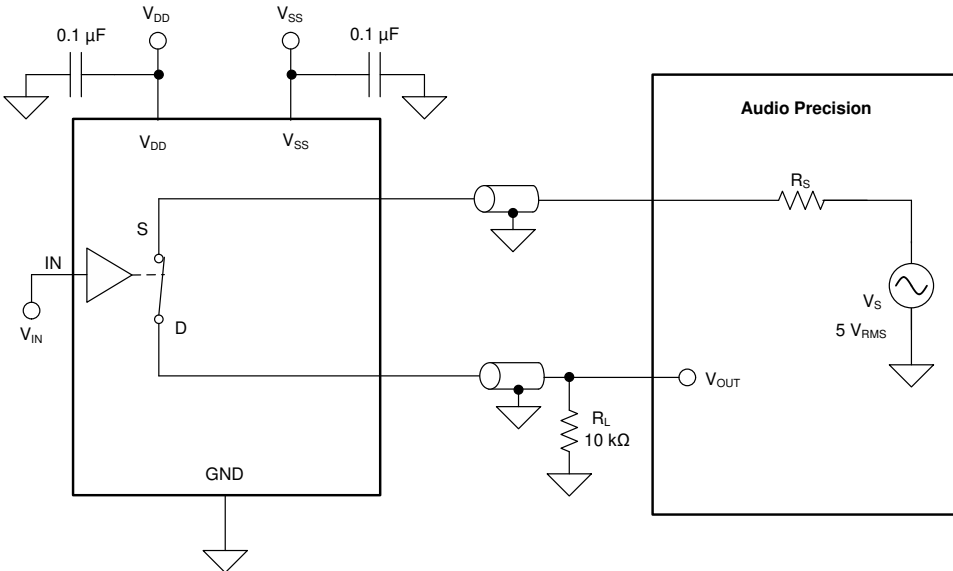
The total harmonic distortion (THD) of a signal is a measurement of the harmonic distortion, and is defined as the ratio of the sum of the powers of all harmonic components to the power of the fundamental frequency at the mux output. The on-resistance of the MUX36xxx varies with the amplitude of the input signal and results in distortion when the drain pin is connected to a low-impedance load. Total harmonic distortion plus noise is denoted as THD+N.  shows the setup used to measure THD+N of the MUX36xxx.

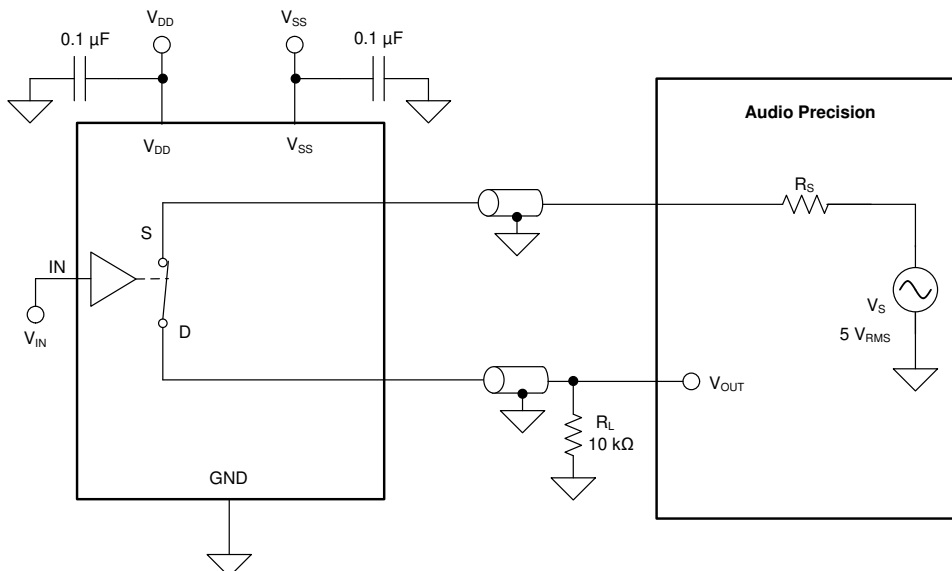

 **37. THD+N Measurement Setup**

## 8 Detailed Description

### 8.1 Overview

The MUX36xxx are a family of analog multiplexers. The *Functional Block Diagram* section provides a top-level block diagram of both the MUX36S16 and MUX36D08. The MUX36S16 is a 16-channel, single-ended, analog mux. The MUX36D08 is an 8-channel, differential or dual 8:1, single-ended, analog mux. Each channel is turned on or turned off based on the state of the address lines and enable pin.

### 8.2 Functional Block Diagram

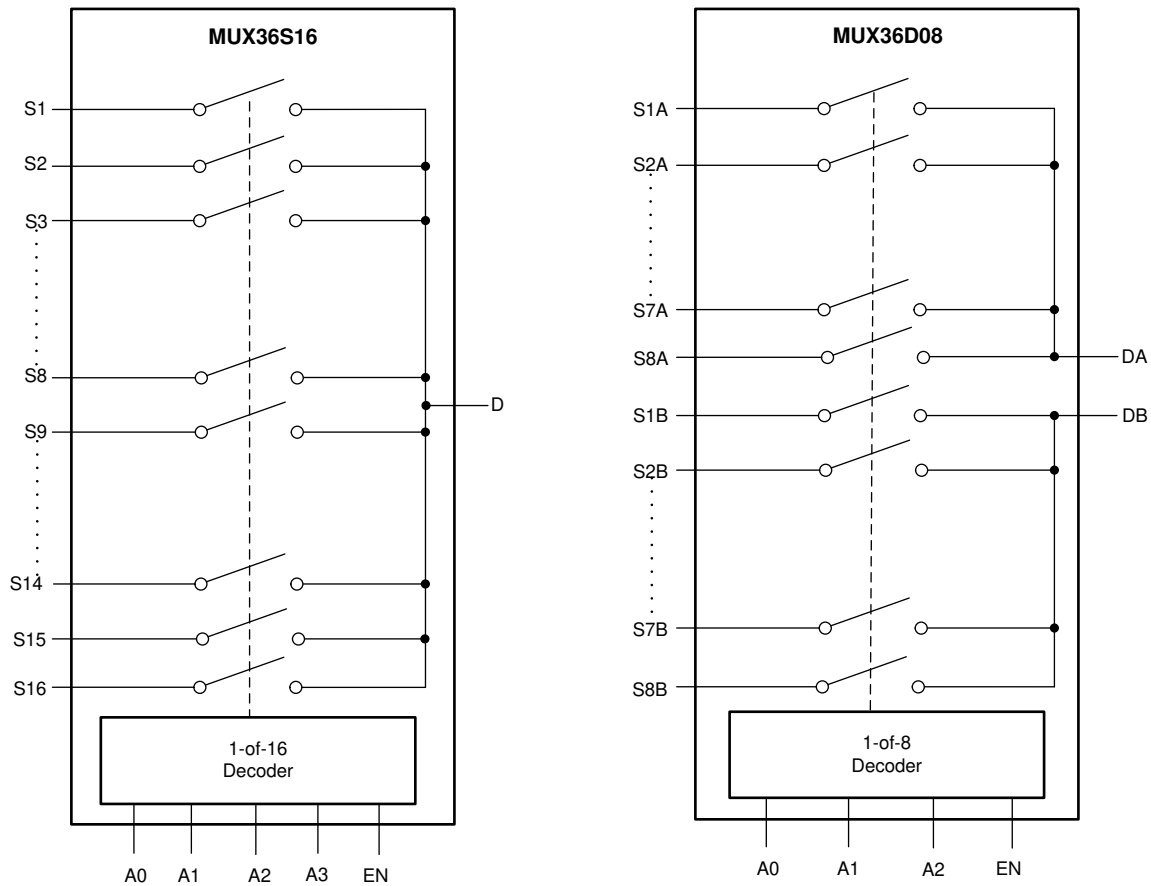

### 8.3 Feature Description

#### 8.3.1 Ultralow Leakage Current

The MUX36xxx provide extremely low on- and off-leakage currents. The MUX36xxx are capable of switching signals from high source-impedance inputs into a high input-impedance op amp with minimal offset error because of the ultra-low leakage currents. [Figure 38](#) shows typical leakage currents of the MUX36xxx versus temperature.

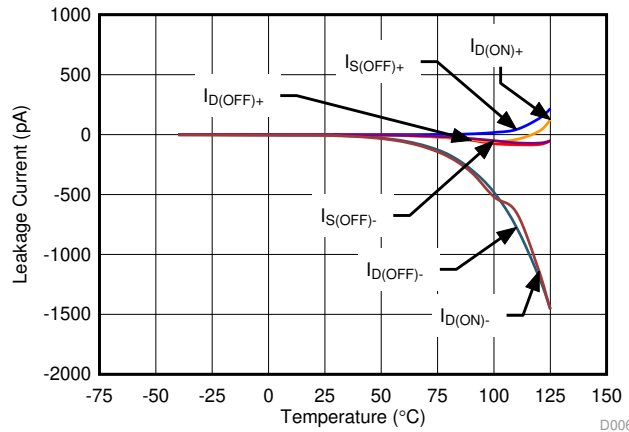

**Figure 38. Leakage Current vs Temperature**

#### 8.3.2 Ultralow Charge Injection

The MUX36xxx have a simple transmission gate topology, as shown in [Figure 39](#). Any mismatch in the stray capacitance associated with the NMOS and PMOS causes an output level change whenever the switch is opened or closed.

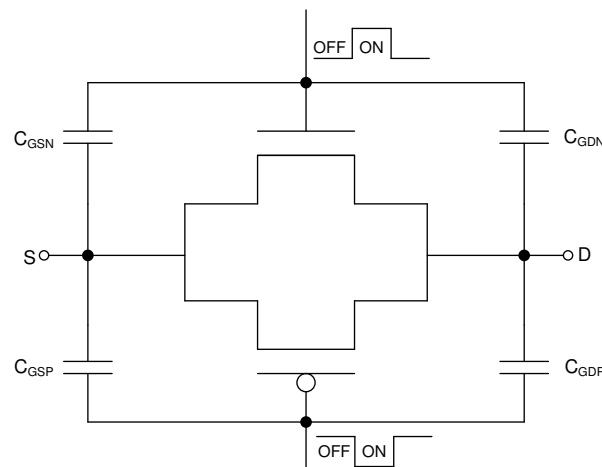

**Figure 39. Transmission Gate Topology**

### Feature Description (continued)

The MUX36xxx have special charge-injection cancellation circuitry that reduces the source-to-drain charge injection to as low as 0.31 pC at  $V_S = 0$  V, and  $\pm 0.9$  pC in the full signal range, as shown in [Figure 40](#).

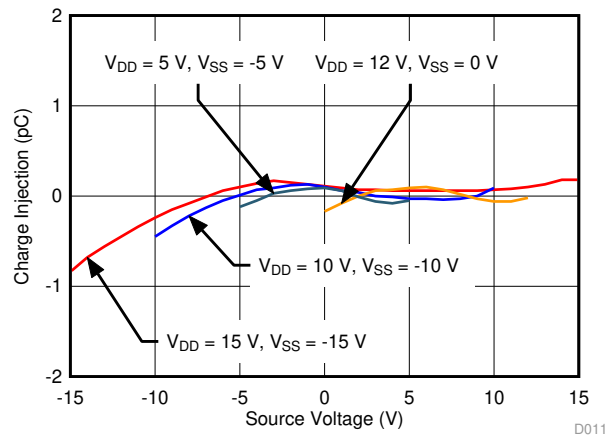

**Figure 40. Source-to-Drain Charge Injection**

The drain-to-source charge injection becomes important when the device is used as a demultiplexer (demux), where D becomes the input and Sx becomes the output. [Figure 41](#) shows the drain-to-source charge injection across the full signal range.

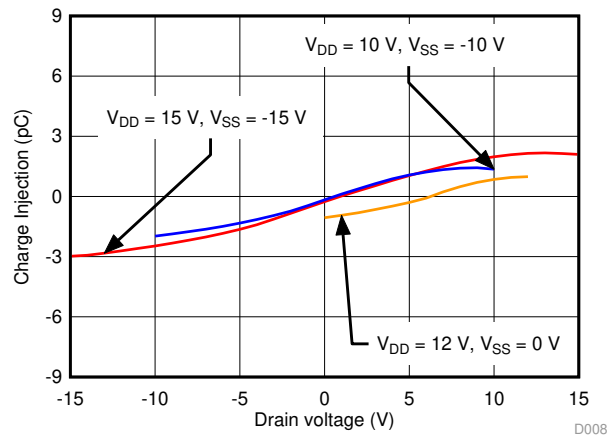

**Figure 41. Drain-to-Source Charge Injection**

## Feature Description (continued)

### 8.3.3 Bidirectional Operation

The MUX36xxx are operable as both a mux and demux. The source (Sx, SxA, SxB) and drain (D, DA, DB) pins of the MUX36xxx are used either as input or output. Each MUX36xxx channel has very similar characteristics in both directions.

### 8.3.4 Rail-to-Rail Operation

The valid analog signal for the MUX36xxx ranges from  $V_{SS}$  to  $V_{DD}$ . The input signal to the MUX36xxx swings from  $V_{SS}$  to  $V_{DD}$  without any significant degradation in performance. The on-resistance of the MUX36xxx varies with input signal, as shown in [Figure 42](#)

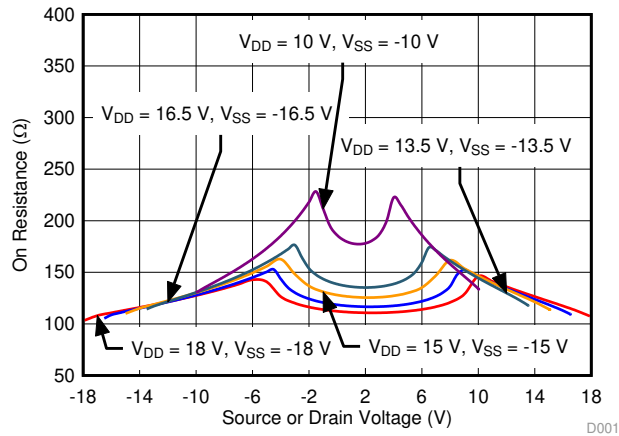

**Figure 42. On-resistance vs Source or Drain Voltage**

## 8.4 Device Functional Modes

When the EN pin of the MUX36xxx is pulled high, one of the switches is closed based on the state of the address lines. When the EN pin is pulled low, all the switches are in an open state irrespective of the state of the address lines. The EN pin can be connected to  $V_{DD}$  (as high as 36 V).

## 9 Application and Implementation

### 注

Information in the following applications sections is not part of the TI component specification, and TI does not warrant its accuracy or completeness. TI's customers are responsible for determining suitability of components for their purposes. Customers should validate and test their design implementation to confirm system functionality.

### 9.1 Application Information

The MUX36xxx family offers outstanding input/output leakage currents and ultra-low charge injection. These devices operate up to 36 V, and offer true rail-to-rail input and output. The on-capacitance of the MUX36xxx is very low. These features makes the MUX36xxx a family of precision, robust, high-performance analog multiplexer for high-voltage, industrial applications.

### 9.2 Typical Application

Figure 43 shows a 16-bit, differential, 8-channel, multiplexed, data-acquisition system. This example is typical in industrial applications that require low distortion and a high-voltage differential input. The circuit uses the ADS8864, a 16-bit, 400-kSPS successive-approximation-resistor (SAR) analog-to-digital converter (ADC), along with a precision, high-voltage, signal-conditioning front end, and a 4-channel differential mux. This TI Precision Design details the process for optimizing the precision, high-voltage, front-end drive circuit using the MUX36D08, OPA192 and OPA140 to achieve excellent dynamic performance and linearity with the ADS8864.

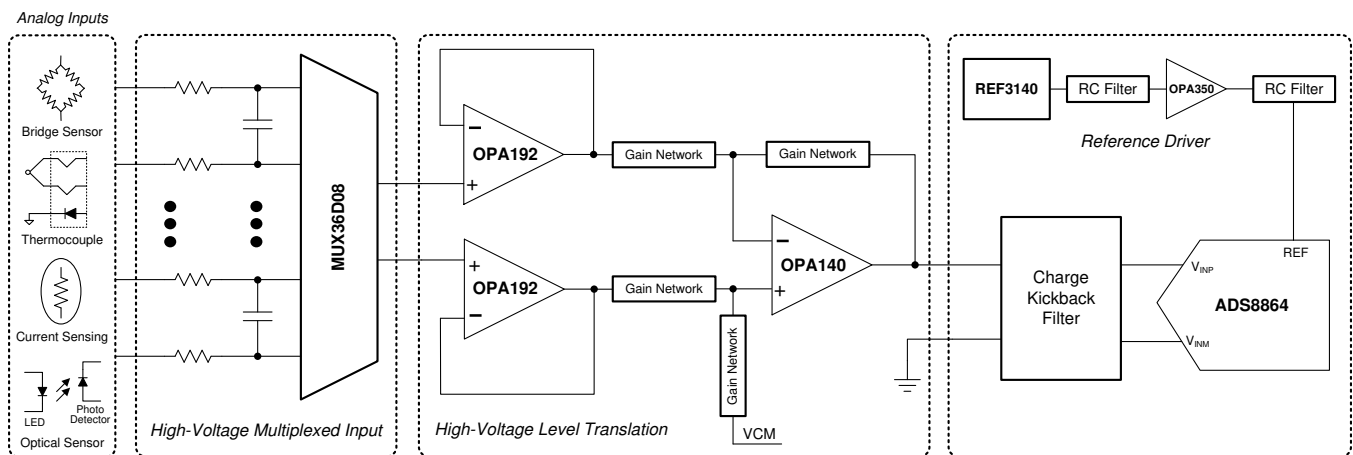

Figure 43. 16-Bit Precision Multiplexed Data-Acquisition System for High-Voltage Inputs With Lowest Distortion

#### 9.2.1 Design Requirements

The primary objective is to design a  $\pm 20$  V, differential, 8-channel, multiplexed, data-acquisition system with lowest distortion using the 16-bit ADS8864 at a throughput of 400 kSPS for a 10-kHz, full-scale, pure, sine-wave input. The design requirements for this block design are:

- System supply voltage:  $\pm 15$  V
- ADC supply voltage: 3.3 V
- ADC sampling rate: 400 kSPS
- ADC reference voltage (REFP): 4.096 V
- System input signal: A high-voltage differential input signal with a peak amplitude of 20 V and frequency ( $f_{IN}$ ) of 10 kHz are applied to each differential input of the mux.

## Typical Application (continued)

### 9.2.2 Detailed Design Procedure

The purpose of this precision design is to design an optimal, high-voltage, multiplexed, data-acquisition system for highest system linearity and fast settling. The overall system block diagram is illustrated in [Figure 43](#). The circuit is a multichannel, data-acquisition signal chain consisting of an input low-pass filter, mux, mux output buffer, attenuating SAR ADC driver, and the reference driver. The architecture allows fast sampling of multiple channels using a single ADC, providing a low-cost solution. This design systematically approaches each analog circuit block to achieve a 16-bit settling for a full-scale input stage voltage and linearity for a 10-kHz sinusoidal input signal at each input channel. Detailed design considerations and component selection procedure can be found in the TI Precision Design [TIPD151](#), *16-Bit, 400-kSPS, 4-Channel Multiplexed Data-Acquisition System for High-Voltage Inputs with Lowest Distortion*.

### 9.2.3 Application Curve

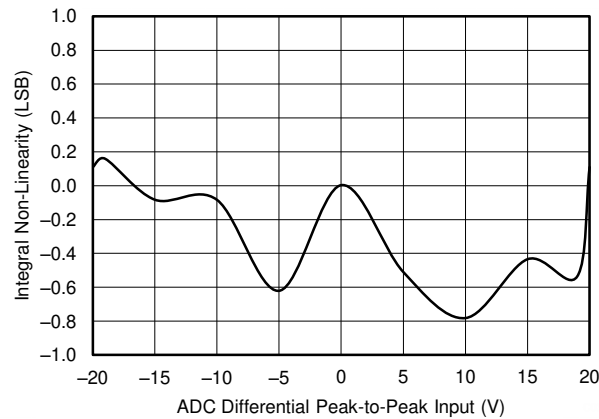
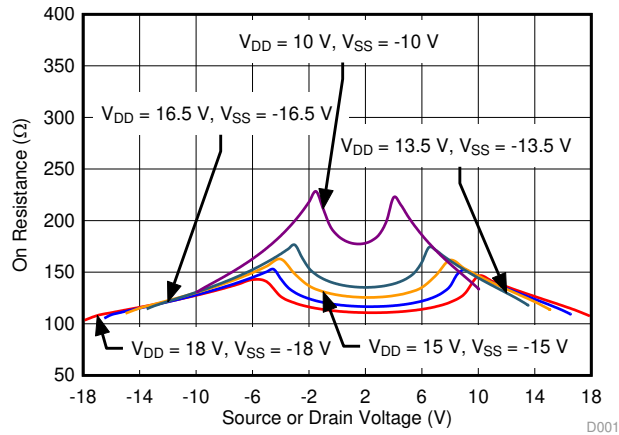

**Figure 44. ADC 16-Bit Linearity Error for the Multiplexed Data-Acquisition Block**

## 10 Power Supply Recommendations

The MUX36xxx operates across a wide supply range of  $\pm 5$  V to  $\pm 18$  V (10 V to 36 V in single-supply mode). The devices also perform well with unsymmetric supplies such as  $V_{DD} = 12$  V and  $V_{SS} = -5$  V. For reliable operation, use a supply decoupling capacitor ranging between 0.1  $\mu$ F to 10  $\mu$ F at both the VDD and VSS pins to ground.

The on-resistance of the MUX36xxx varies with supply voltage, as illustrated in [Figure 45](#)



**Figure 45. On-Resistance Variation With Supply and Input Voltage**

## 11 Layout

### 11.1 Layout Guidelines

☒ 46 illustrates an example of a PCB layout with the MUX36S16IPW, and ☒ 47 illustrates an example of a PCB layout with MUX36D08IPW.

Some key considerations are:

1. Decouple the VDD and VSS pins with a 0.1- $\mu$ F capacitor, placed as close to the pin as possible. Make sure that the capacitor voltage rating is sufficient for the  $V_{DD}$  and  $V_{SS}$  supplies.
2. Keep the input lines as short as possible. In case of the differential signal, make sure the A inputs and B inputs are as symmetric as possible.
3. Use a solid ground plane to help distribute heat and reduce electromagnetic interference (EMI) noise pickup.
4. Do not run sensitive analog traces in parallel with digital traces. Avoid crossing digital and analog traces if possible, and only make perpendicular crossings when necessary.

### 11.2 Layout Example

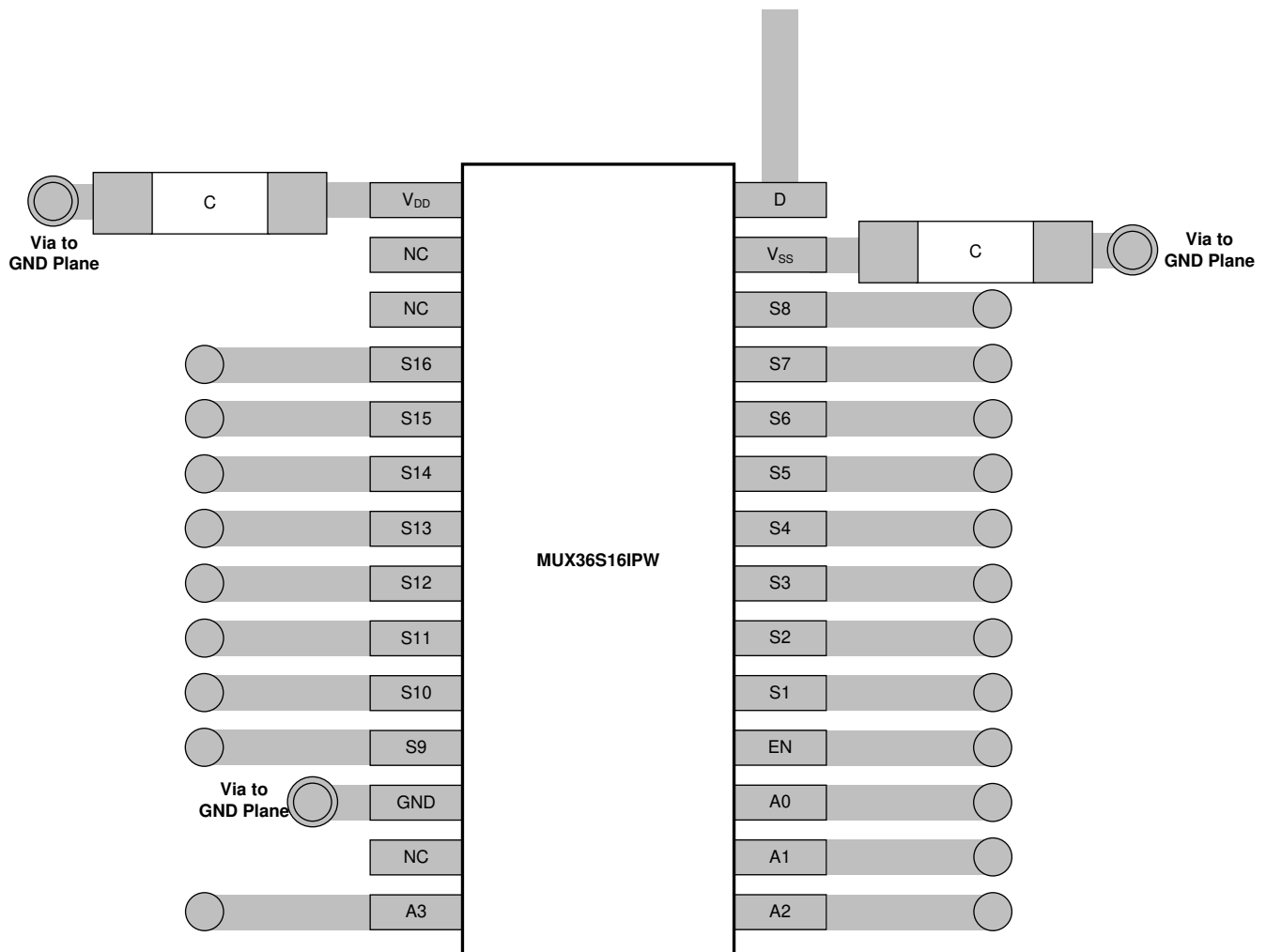

☒ 46. MUX36S16IPW Layout Example

**Layout Example (continued)**

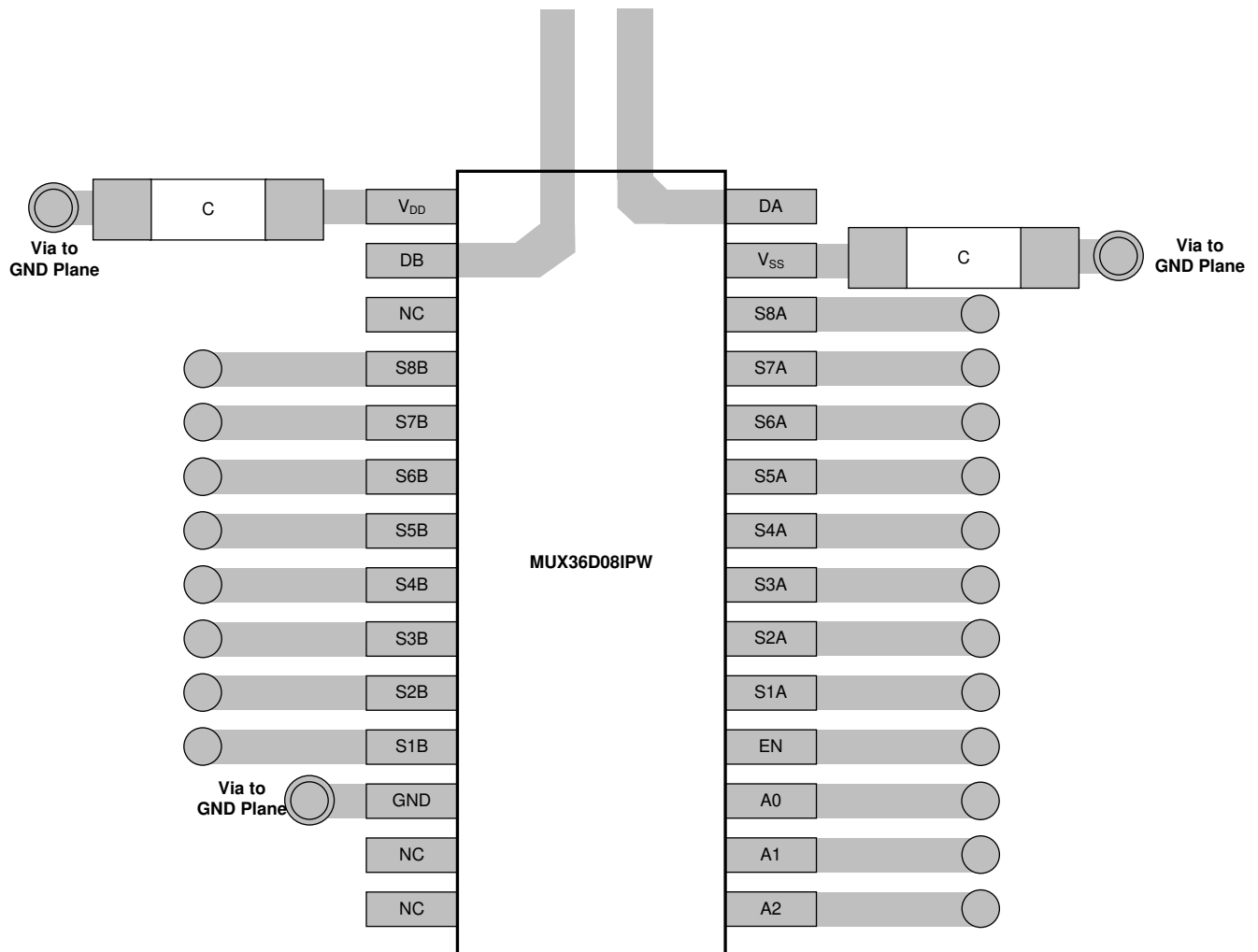

**图 47. MUX36D08IPW Layout Example**

## 12 デバイスおよびドキュメントのサポート

### 12.1 ドキュメントのサポート

#### 12.1.1 関連資料

関連資料については、以下を参照してください。

- 『ADS8864 16ビット、400kSPS、シリアル・インターフェイス、microPower、小型、シングルエンド入力、SARアナログ・デジタル・コンバータ』(SBAS572)
- 『OPAx192 36V、高精度、レール・ツー・レール入力/出力、低オフセット電圧、e-trim低入力バイアス電流オペアンプ』(SBOS620)
- 『OPAx140高精度、低ノイズ、レール・ツー・レール出力、11MHz JFETオペアンプ』(SBOS498)

### 12.2 関連リンク

次の表に、クイック・アクセス・リンクを示します。カテゴリには、技術資料、サポートおよびコミュニティ・リソース、ツールとソフトウェア、およびご注文へのクイック・アクセスが含まれます。

表 3. 関連リンク

製品	プロダクト・フォルダ	ご注文はこちら	技術資料	ツールとソフトウェア	サポートとコミュニティ
MUX36S16	<a href="#">ここをクリック</a>	<a href="#">ここをクリック</a>	<a href="#">ここをクリック</a>	<a href="#">ここをクリック</a>	<a href="#">ここをクリック</a>
MUX36D08	<a href="#">ここをクリック</a>	<a href="#">ここをクリック</a>	<a href="#">ここをクリック</a>	<a href="#">ここをクリック</a>	<a href="#">ここをクリック</a>

### 12.3 ドキュメントの更新通知を受け取る方法

ドキュメントの更新についての通知を受け取るには、ti.comのデバイス製品フォルダを開いてください。右上の「アラートを受け取る」をクリックして登録すると、変更されたすべての製品情報に関するダイジェストを毎週受け取れます。変更の詳細については、修正されたドキュメントに含まれている改訂履歴をご覧ください。

### 12.4 コミュニティ・リソース

TI E2E™ support forums are an engineer's go-to source for fast, verified answers and design help — straight from the experts. Search existing answers or ask your own question to get the quick design help you need.

Linked content is provided "AS IS" by the respective contributors. They do not constitute TI specifications and do not necessarily reflect TI's views; see TI's [Terms of Use](#).

### 12.5 商標

E2E is a trademark of Texas Instruments.  
All other trademarks are the property of their respective owners.

### 12.6 静電気放電に関する注意事項



すべての集積回路は、適切なESD保護方法を用いて、取扱いと保存を行うようにして下さい。

静電気放電はわずかな性能の低下から完全なデバイスの故障に至るまで、様々な損傷を与えます。高精度の集積回路は、損傷に対して敏感であり、極めてわずかなパラメータの変化により、デバイスに規定された仕様に適合しなくなる場合があります。

### 12.7 Glossary

SLYZ022 — TI Glossary.

This glossary lists and explains terms, acronyms, and definitions.

## 13 メカニカル、パッケージ、および注文情報

以降のページには、メカニカル、パッケージ、および注文に関する情報が記載されています。この情報は、そのデバイスについて利用可能な最新のデータです。このデータは予告なく変更されることがあり、ドキュメントが改訂される場合もあります。本データシートのブラウザ版を使用されている場合は、画面左側の説明をご覧ください。

**PACKAGING INFORMATION**

Orderable part number	Status (1)	Material type (2)	Package   Pins	Package qty   Carrier	RoHS (3)	Lead finish/ Ball material (4)	MSL rating/ Peak reflow (5)	Op temp (°C)	Part marking (6)
<a href="#">MUX36D08IDWR</a>	Active	Production	SOIC (DW)   28	1000   LARGE T&R	Yes	NIPDAU	Level-3-260C-168 HR	-40 to 125	MUX36D08D
MUX36D08IDWR.B	Active	Production	SOIC (DW)   28	1000   LARGE T&R	Yes	NIPDAU	Level-3-260C-168 HR	-40 to 125	MUX36D08D
MUX36D08IDWRG4	Active	Production	SOIC (DW)   28	1000   LARGE T&R	Yes	NIPDAU	Level-3-260C-168 HR	-40 to 125	MUX36D08D
MUX36D08IDWRG4.B	Active	Production	SOIC (DW)   28	1000   LARGE T&R	Yes	NIPDAU	Level-3-260C-168 HR	-40 to 125	MUX36D08D
<a href="#">MUX36D08IPW</a>	Active	Production	TSSOP (PW)   28	50   TUBE	Yes	NIPDAU	Level-3-260C-168 HR	-40 to 125	MUX36D080A
MUX36D08IPW.B	Active	Production	TSSOP (PW)   28	50   TUBE	Yes	NIPDAU	Level-3-260C-168 HR	-40 to 125	MUX36D080A
<a href="#">MUX36D08IPWR</a>	Active	Production	TSSOP (PW)   28	2000   LARGE T&R	Yes	NIPDAU	Level-3-260C-168 HR	-40 to 125	MUX36D080A
MUX36D08IPWR.B	Active	Production	TSSOP (PW)   28	2000   LARGE T&R	Yes	NIPDAU	Level-3-260C-168 HR	-40 to 125	MUX36D080A
MUX36D08IPWRG4	Active	Production	TSSOP (PW)   28	2000   LARGE T&R	Yes	NIPDAU	Level-3-260C-168 HR	-40 to 125	MUX36D080A
MUX36D08IPWRG4.B	Active	Production	TSSOP (PW)   28	2000   LARGE T&R	Yes	NIPDAU	Level-3-260C-168 HR	-40 to 125	MUX36D080A
<a href="#">MUX36D08IRSNR</a>	Active	Production	QFN (RSN)   32	3000   LARGE T&R	Yes	SN	Level-1-260C-UNLIM	-40 to 125	MUX 36D08
MUX36D08IRSNR.B	Active	Production	QFN (RSN)   32	3000   LARGE T&R	Yes	SN	Level-1-260C-UNLIM	-40 to 125	MUX 36D08
MUX36D08IRSNRG4	Active	Production	QFN (RSN)   32	3000   LARGE T&R	Yes	NIPDAU	Level-1-260C-UNLIM	-40 to 125	MUX 36D08
MUX36D08IRSNRG4.B	Active	Production	QFN (RSN)   32	3000   LARGE T&R	Yes	NIPDAU	Level-1-260C-UNLIM	-40 to 125	MUX 36D08
<a href="#">MUX36D08IRTVR</a>	Active	Production	WQFN (RTV)   32	3000   LARGE T&R	Yes	NIPDAU	Level-1-260C-UNLIM	-40 to 125	MUX 36D08
MUX36D08IRTVR.B	Active	Production	WQFN (RTV)   32	3000   LARGE T&R	Yes	NIPDAU	Level-1-260C-UNLIM	-40 to 125	MUX 36D08
<a href="#">MUX36S16IDWR</a>	Active	Production	SOIC (DW)   28	1000   LARGE T&R	Yes	NIPDAU	Level-3-260C-168 HR	-40 to 125	MUX36S16DA
MUX36S16IDWR.B	Active	Production	SOIC (DW)   28	1000   LARGE T&R	Yes	NIPDAU	Level-3-260C-168 HR	-40 to 125	MUX36S16DA
<a href="#">MUX36S16IPW</a>	Active	Production	TSSOP (PW)   28	50   TUBE	Yes	NIPDAU	Level-3-260C-168 HR	-40 to 125	MUX36S160A
MUX36S16IPW.B	Active	Production	TSSOP (PW)   28	50   TUBE	Yes	NIPDAU	Level-3-260C-168 HR	-40 to 125	MUX36S160A
<a href="#">MUX36S16IPWR</a>	Active	Production	TSSOP (PW)   28	2000   LARGE T&R	Yes	NIPDAU	Level-3-260C-168 HR	-40 to 125	MUX36S160A
MUX36S16IPWR.B	Active	Production	TSSOP (PW)   28	2000   LARGE T&R	Yes	NIPDAU	Level-3-260C-168 HR	-40 to 125	MUX36S160A
<a href="#">MUX36S16IRSNR</a>	Active	Production	QFN (RSN)   32	3000   LARGE T&R	Yes	NIPDAU	Level-1-260C-UNLIM	-40 to 125	MUX 36S16

Orderable part number	Status (1)	Material type (2)	Package   Pins	Package qty   Carrier	RoHS (3)	Lead finish/ Ball material (4)	MSL rating/ Peak reflow (5)	Op temp (°C)	Part marking (6)
MUX36S16IRSNR.B	Active	Production	QFN (RSN)   32	3000   LARGE T&R	Yes	NIPDAU	Level-1-260C-UNLIM	-40 to 125	MUX 36S16
MUX36S16IRSNRG4	Active	Production	QFN (RSN)   32	3000   LARGE T&R	Yes	NIPDAU	Level-1-260C-UNLIM	-40 to 125	MUX 36S16
MUX36S16IRSNRG4.B	Active	Production	QFN (RSN)   32	3000   LARGE T&R	Yes	NIPDAU	Level-1-260C-UNLIM	-40 to 125	MUX 36S16
<a href="#">MUX36S16IRTVR</a>	Active	Production	WQFN (RTV)   32	3000   LARGE T&R	Yes	NIPDAU	Level-1-260C-UNLIM	-40 to 125	MUX 36S16
MUX36S16IRTVR.B	Active	Production	WQFN (RTV)   32	3000   LARGE T&R	Yes	NIPDAU	Level-1-260C-UNLIM	-40 to 125	MUX 36S16

(1) **Status:** For more details on status, see our [product life cycle](#).

(2) **Material type:** When designated, preproduction parts are prototypes/experimental devices, and are not yet approved or released for full production. Testing and final process, including without limitation quality assurance, reliability performance testing, and/or process qualification, may not yet be complete, and this item is subject to further changes or possible discontinuation. If available for ordering, purchases will be subject to an additional waiver at checkout, and are intended for early internal evaluation purposes only. These items are sold without warranties of any kind.

(3) **RoHS values:** Yes, No, RoHS Exempt. See the [TI RoHS Statement](#) for additional information and value definition.

(4) **Lead finish/Ball material:** Parts may have multiple material finish options. Finish options are separated by a vertical ruled line. Lead finish/Ball material values may wrap to two lines if the finish value exceeds the maximum column width.

(5) **MSL rating/Peak reflow:** The moisture sensitivity level ratings and peak solder (reflow) temperatures. In the event that a part has multiple moisture sensitivity ratings, only the lowest level per JEDEC standards is shown. Refer to the shipping label for the actual reflow temperature that will be used to mount the part to the printed circuit board.

(6) **Part marking:** There may be an additional marking, which relates to the logo, the lot trace code information, or the environmental category of the part.

Multiple part markings will be inside parentheses. Only one part marking contained in parentheses and separated by a "~" will appear on a part. If a line is indented then it is a continuation of the previous line and the two combined represent the entire part marking for that device.

**Important Information and Disclaimer:** The information provided on this page represents TI's knowledge and belief as of the date that it is provided. TI bases its knowledge and belief on information provided by third parties, and makes no representation or warranty as to the accuracy of such information. Efforts are underway to better integrate information from third parties. TI has taken and continues to take reasonable steps to provide representative and accurate information but may not have conducted destructive testing or chemical analysis on incoming materials and chemicals. TI and TI suppliers consider certain information to be proprietary, and thus CAS numbers and other limited information may not be available for release.

In no event shall TI's liability arising out of such information exceed the total purchase price of the TI part(s) at issue in this document sold by TI to Customer on an annual basis.

**TAPE AND REEL INFORMATION**

**QUADRANT ASSIGNMENTS FOR PIN 1 ORIENTATION IN TAPE**



\*All dimensions are nominal

Device	Package Type	Package Drawing	Pins	SPQ	Reel Diameter (mm)	Reel Width W1 (mm)	A0 (mm)	B0 (mm)	K0 (mm)	P1 (mm)	W (mm)	Pin1 Quadrant
MUX36D08IDWR	SOIC	DW	28	1000	330.0	32.4	11.35	18.67	3.1	16.0	32.0	Q1
MUX36D08IDWRG4	SOIC	DW	28	1000	330.0	32.4	11.35	18.67	3.1	16.0	32.0	Q1
MUX36D08IPWR	TSSOP	PW	28	2000	330.0	16.4	6.9	10.2	1.8	12.0	16.0	Q1
MUX36D08IPWR	TSSOP	PW	28	2000	330.0	16.4	6.9	10.2	1.8	12.0	16.0	Q1
MUX36D08IPWRG4	TSSOP	PW	28	2000	330.0	16.4	6.9	10.2	1.8	12.0	16.0	Q1
MUX36D08IPWRG4	TSSOP	PW	28	2000	330.0	16.4	6.9	10.2	1.8	12.0	16.0	Q1
MUX36D08IRSNR	QFN	RSN	32	3000	330.0	12.4	4.25	4.25	1.15	8.0	12.0	Q2
MUX36D08IRSNRG4	QFN	RSN	32	3000	330.0	12.4	4.25	4.25	1.15	8.0	12.0	Q2
MUX36D08IRTVR	WQFN	RTV	32	3000	330.0	12.4	5.3	5.3	1.1	8.0	12.0	Q2
MUX36S16IDWR	SOIC	DW	28	1000	330.0	32.4	11.35	18.67	3.1	16.0	32.0	Q1
MUX36S16IPWR	TSSOP	PW	28	2000	330.0	16.4	6.9	10.2	1.8	12.0	16.0	Q1
MUX36S16IPWR	TSSOP	PW	28	2000	330.0	16.4	6.9	10.2	1.8	12.0	16.0	Q1
MUX36S16IRSNR	QFN	RSN	32	3000	330.0	12.4	4.25	4.25	1.15	8.0	12.0	Q2
MUX36S16IRSNRG4	QFN	RSN	32	3000	330.0	12.4	4.25	4.25	1.15	8.0	12.0	Q2
MUX36S16IRTVR	WQFN	RTV	32	3000	330.0	12.4	5.3	5.3	1.1	8.0	12.0	Q2

**TAPE AND REEL BOX DIMENSIONS**

\*All dimensions are nominal

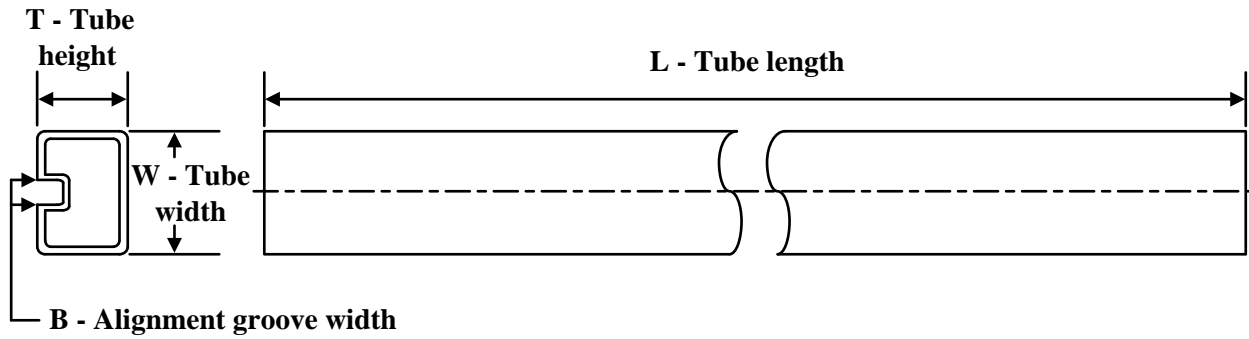
Device	Package Type	Package Drawing	Pins	SPQ	Length (mm)	Width (mm)	Height (mm)
MUX36D08IDWR	SOIC	DW	28	1000	350.0	350.0	66.0
MUX36D08IDWRG4	SOIC	DW	28	1000	350.0	350.0	66.0
MUX36D08IPWR	TSSOP	PW	28	2000	350.0	350.0	43.0
MUX36D08IPWR	TSSOP	PW	28	2000	350.0	350.0	43.0
MUX36D08IPWRG4	TSSOP	PW	28	2000	350.0	350.0	43.0
MUX36D08IPWRG4	TSSOP	PW	28	2000	350.0	350.0	43.0
MUX36D08IRSNR	QFN	RSN	32	3000	367.0	367.0	35.0
MUX36D08IRSNRG4	QFN	RSN	32	3000	367.0	367.0	35.0
MUX36D08IRTVR	WQFN	RTV	32	3000	367.0	367.0	35.0
MUX36S16IDWR	SOIC	DW	28	1000	350.0	350.0	66.0
MUX36S16IPWR	TSSOP	PW	28	2000	350.0	350.0	43.0
MUX36S16IPWR	TSSOP	PW	28	2000	350.0	350.0	43.0
MUX36S16IRSNR	QFN	RSN	32	3000	367.0	367.0	35.0
MUX36S16IRSNRG4	QFN	RSN	32	3000	367.0	367.0	35.0
MUX36S16IRTVR	WQFN	RTV	32	3000	367.0	367.0	35.0

**TUBE**

\*All dimensions are nominal

Device	Package Name	Package Type	Pins	SPQ	L (mm)	W (mm)	T (μm)	B (mm)
MUX36D08IPW	PW	TSSOP	28	50	530	10.2	3600	3.5
MUX36D08IPW.B	PW	TSSOP	28	50	530	10.2	3600	3.5
MUX36S16IPW	PW	TSSOP	28	50	530	10.2	3600	3.5
MUX36S16IPW.B	PW	TSSOP	28	50	530	10.2	3600	3.5

RTV (S-PWQFN-N32)

PLASTIC QUAD FLATPACK NO-LEAD

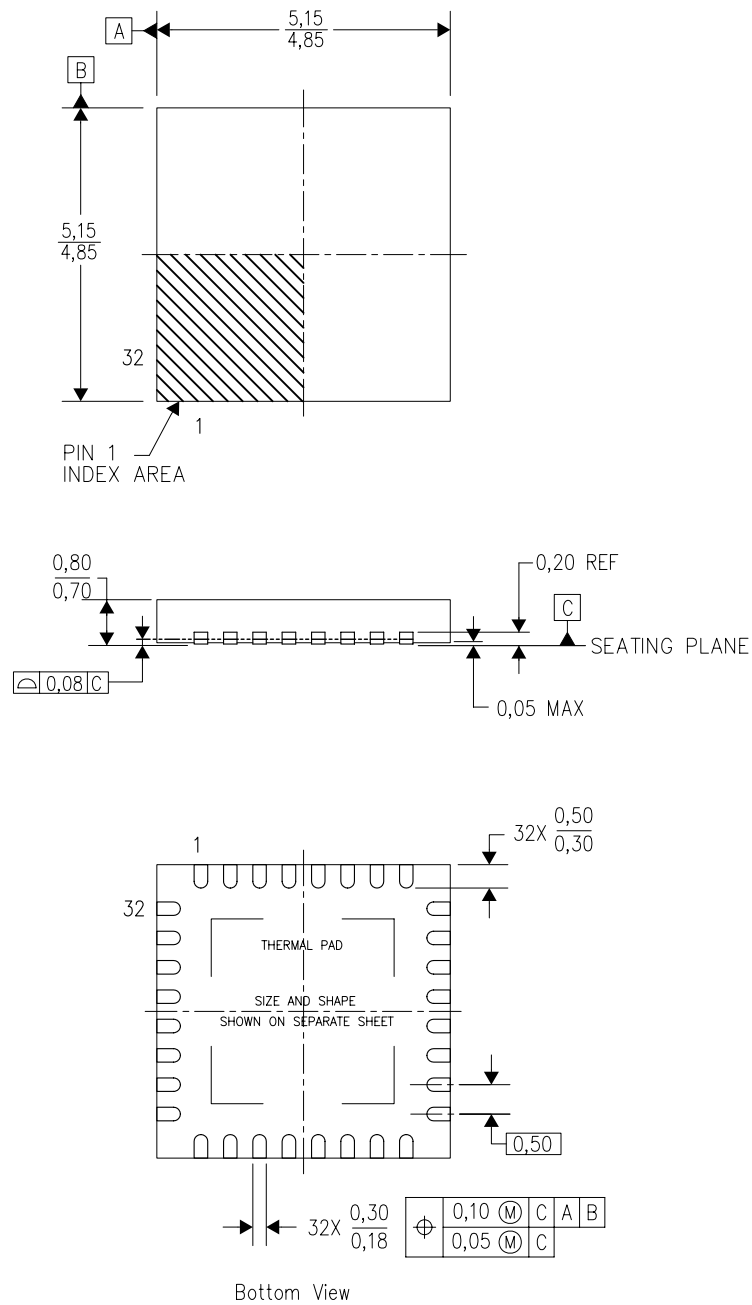

4206245/C 10/11

- NOTES:
- A. All linear dimensions are in millimeters. Dimensioning and tolerancing per ASME Y14.5-1994.
  - B. This drawing is subject to change without notice.
  - C. Quad Flatpack, No-Leads (QFN) package configuration.
  - D. The package thermal pad must be soldered to the board for thermal and mechanical performance.
  - E. See the additional figure in the Product Data Sheet for details regarding the exposed thermal pad features and dimensions.
  - F. Falls within JEDEC MO-220.

# RTV0032E

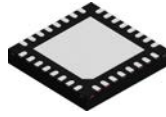

## PACKAGE OUTLINE

WQFN - 0.8 mm max height

PLASTIC QUAD FLATPACK - NO LEAD

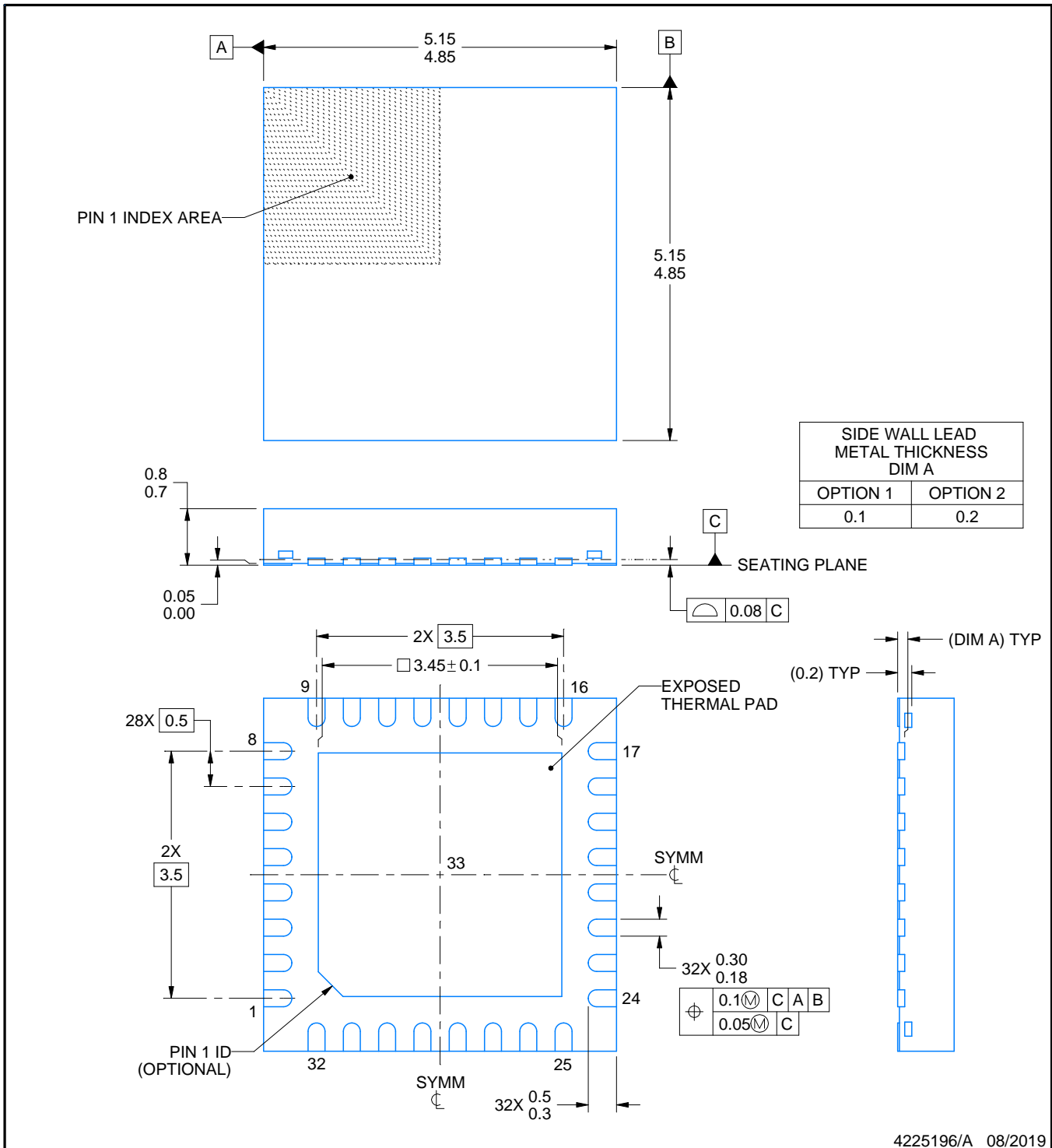

4225196/A 08/2019

### NOTES:

1. All linear dimensions are in millimeters. Any dimensions in parenthesis are for reference only. Dimensioning and tolerancing per ASME Y14.5M.
2. This drawing is subject to change without notice.
3. The package thermal pad must be soldered to the printed circuit board for thermal and mechanical performance.



# EXAMPLE STENCIL DESIGN

RTV0032E

WQFN - 0.8 mm max height

PLASTIC QUAD FLATPACK - NO LEAD

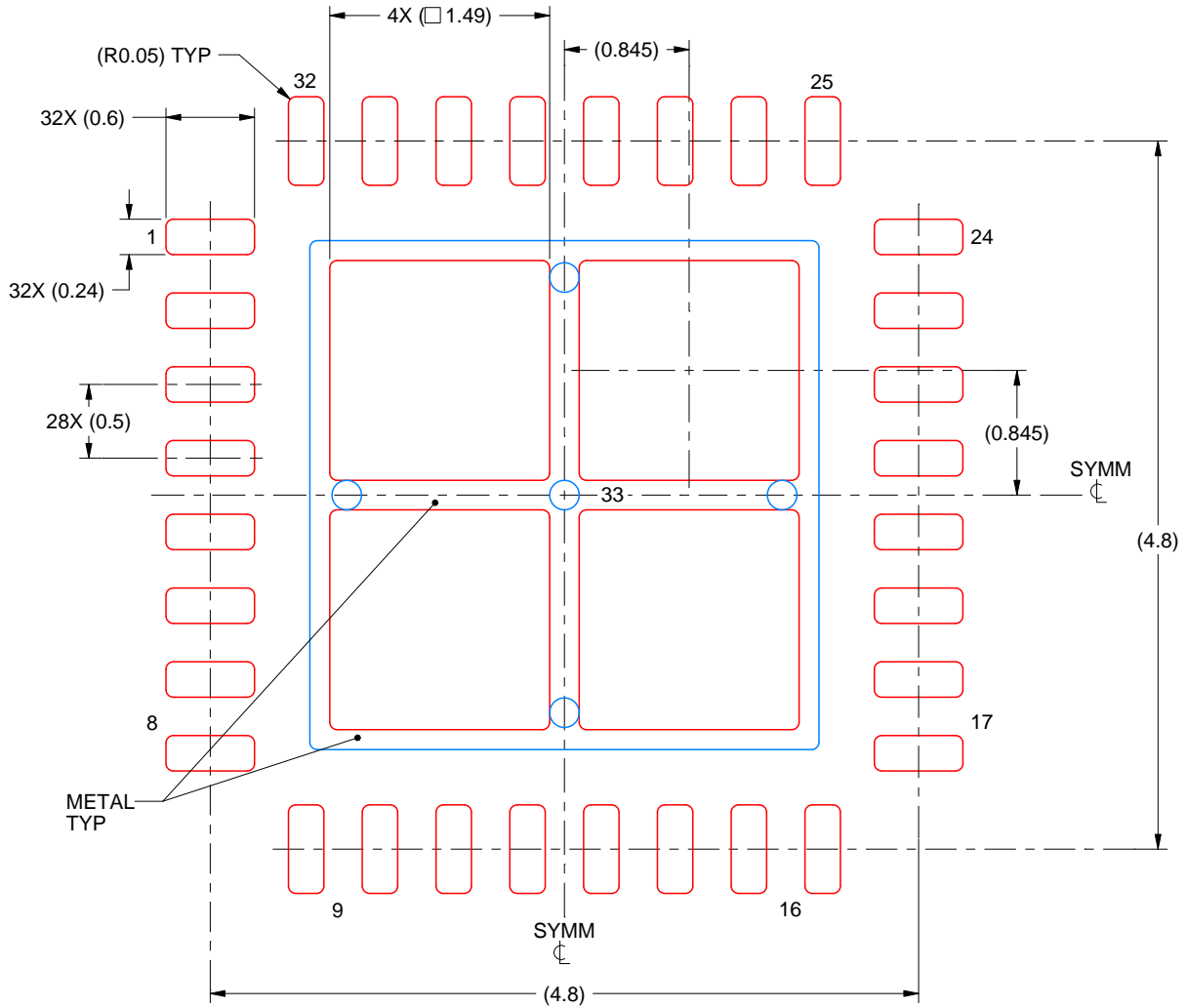

**SOLDER PASTE EXAMPLE**  
 BASED ON 0.125 mm THICK STENCIL

EXPOSED PAD 33:  
 75% PRINTED SOLDER COVERAGE BY AREA UNDER PACKAGE  
 SCALE:20X

4225196/A 08/2019

NOTES: (continued)

6. Laser cutting apertures with trapezoidal walls and rounded corners may offer better paste release. IPC-7525 may have alternate design recommendations.

## GENERIC PACKAGE VIEW

**RSN 32**

**WQFN - 0.8 mm max height**

4 x 4, 0.4 mm pitch

PLASTIC QUAD FLATPACK - NO LEAD

This image is a representation of the package family, actual package may vary.  
Refer to the product data sheet for package details.

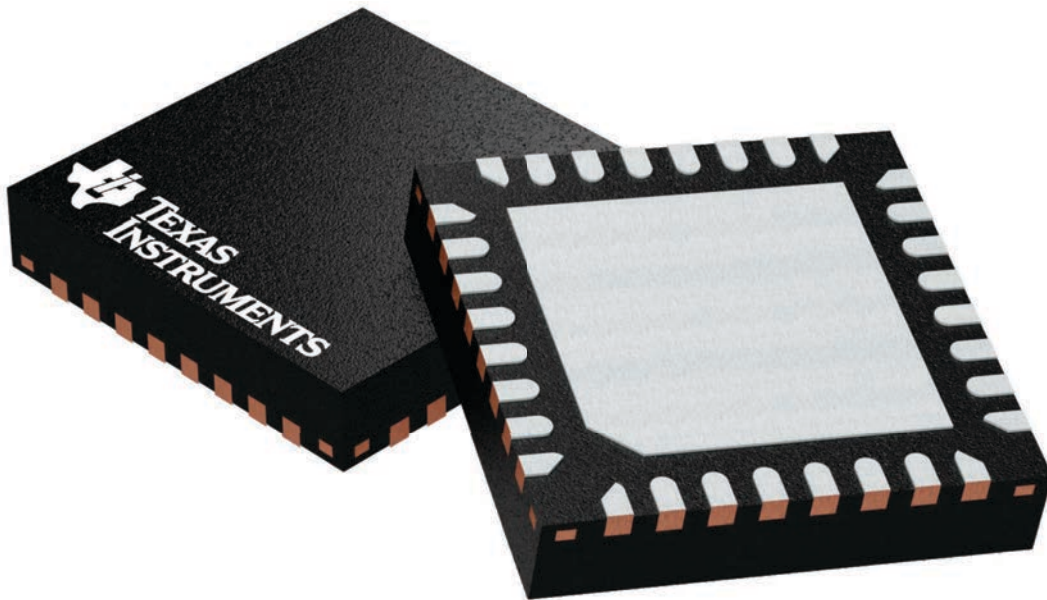

4225265/A

# RSN0032B

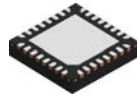

# PACKAGE OUTLINE

## WQFN - 0.8 mm max height

PLASTIC QUAD FLATPACK - NO LEAD

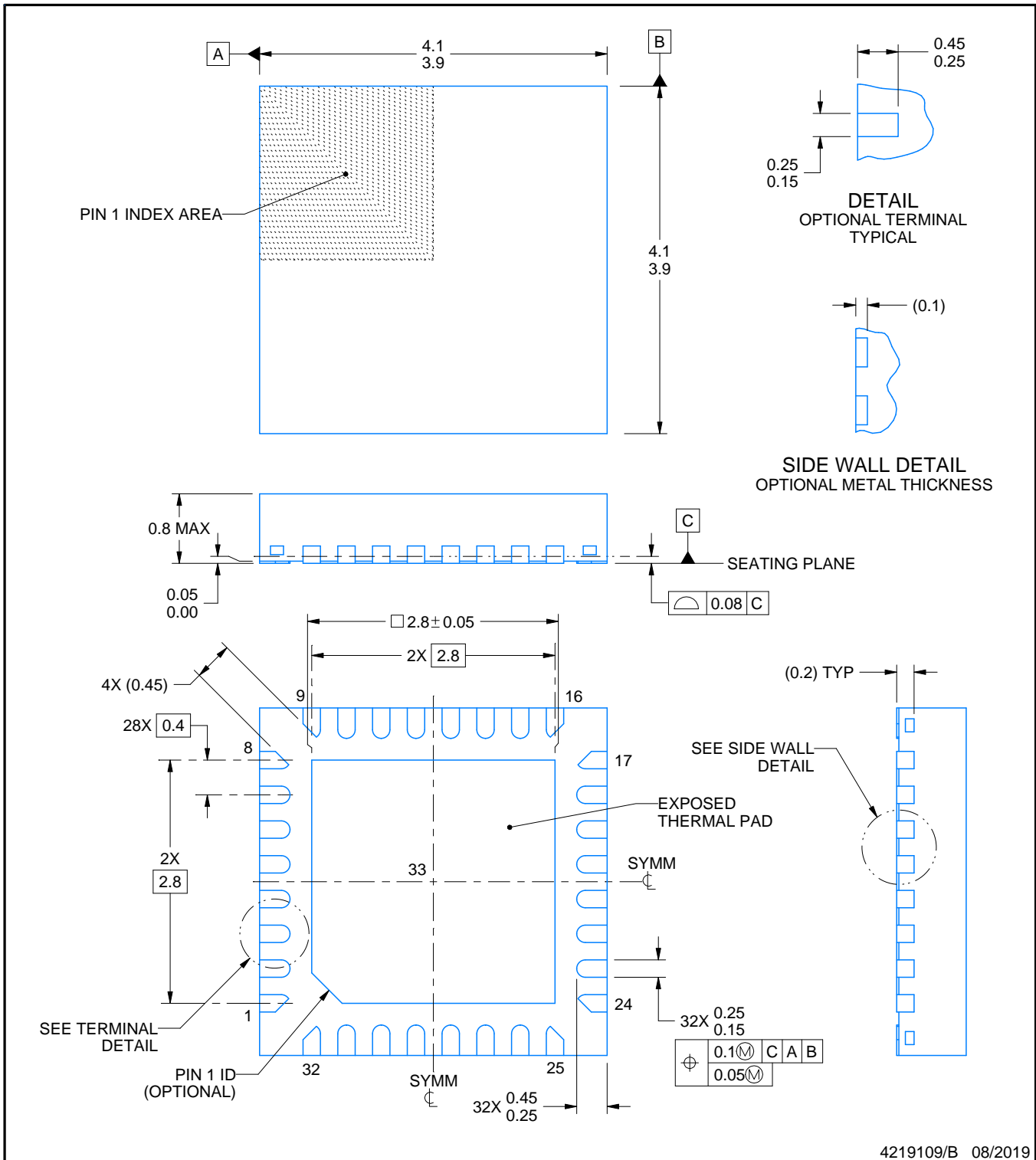

4219109/B 08/2019

### NOTES:

1. All linear dimensions are in millimeters. Any dimensions in parenthesis are for reference only. Dimensioning and tolerancing per ASME Y14.5M.
2. This drawing is subject to change without notice.
3. The package thermal pad must be soldered to the printed circuit board for thermal and mechanical performance.





DW (R-PDSO-G28)

PLASTIC SMALL OUTLINE

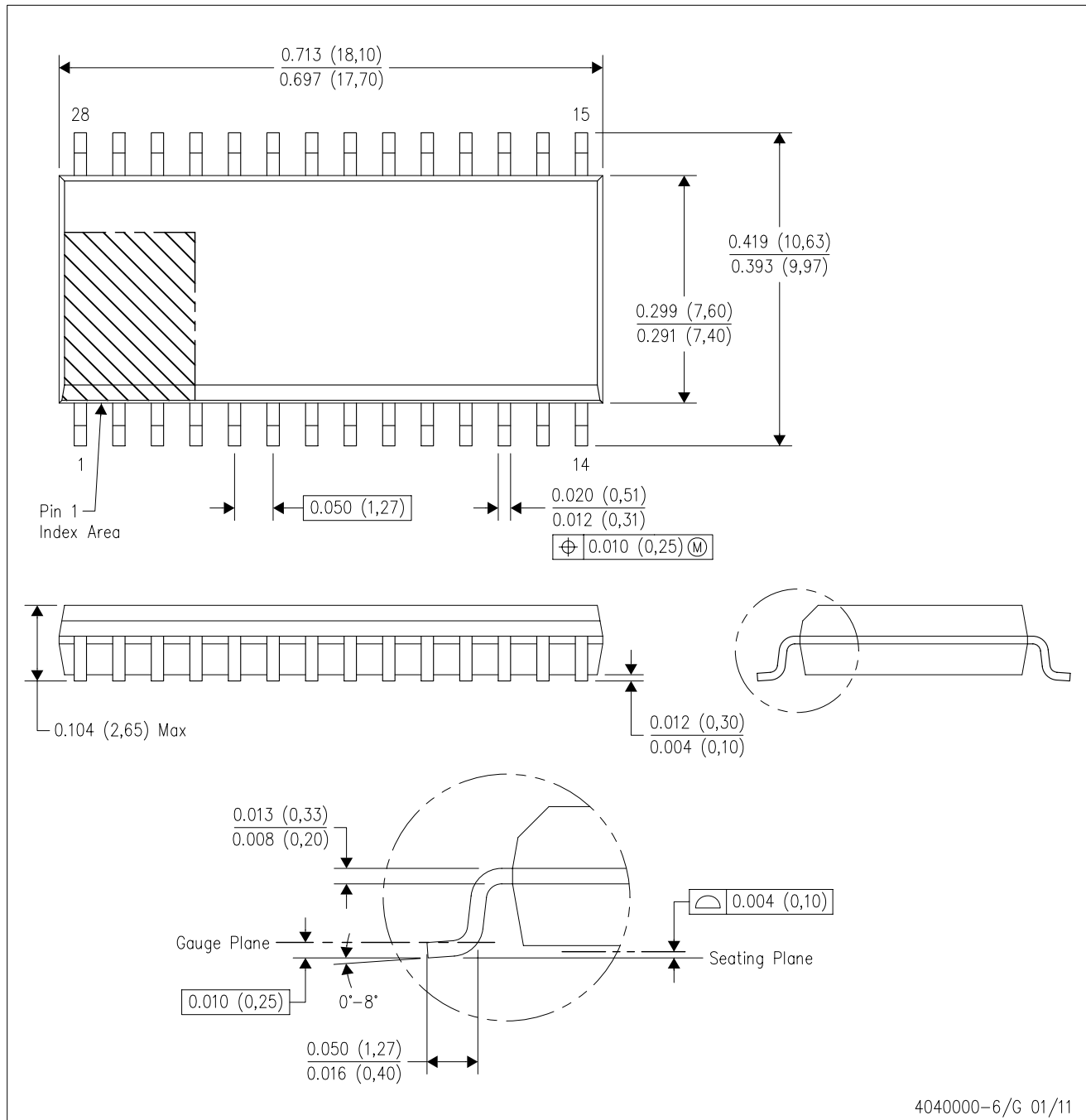

- NOTES:
- All linear dimensions are in inches (millimeters). Dimensioning and tolerancing per ASME Y14.5M-1994.
  - This drawing is subject to change without notice.
  - Body dimensions do not include mold flash or protrusion not to exceed 0.006 (0,15).
  - Falls within JEDEC MS-013 variation AE.

DW (R-PDSO-G28)

PLASTIC SMALL OUTLINE

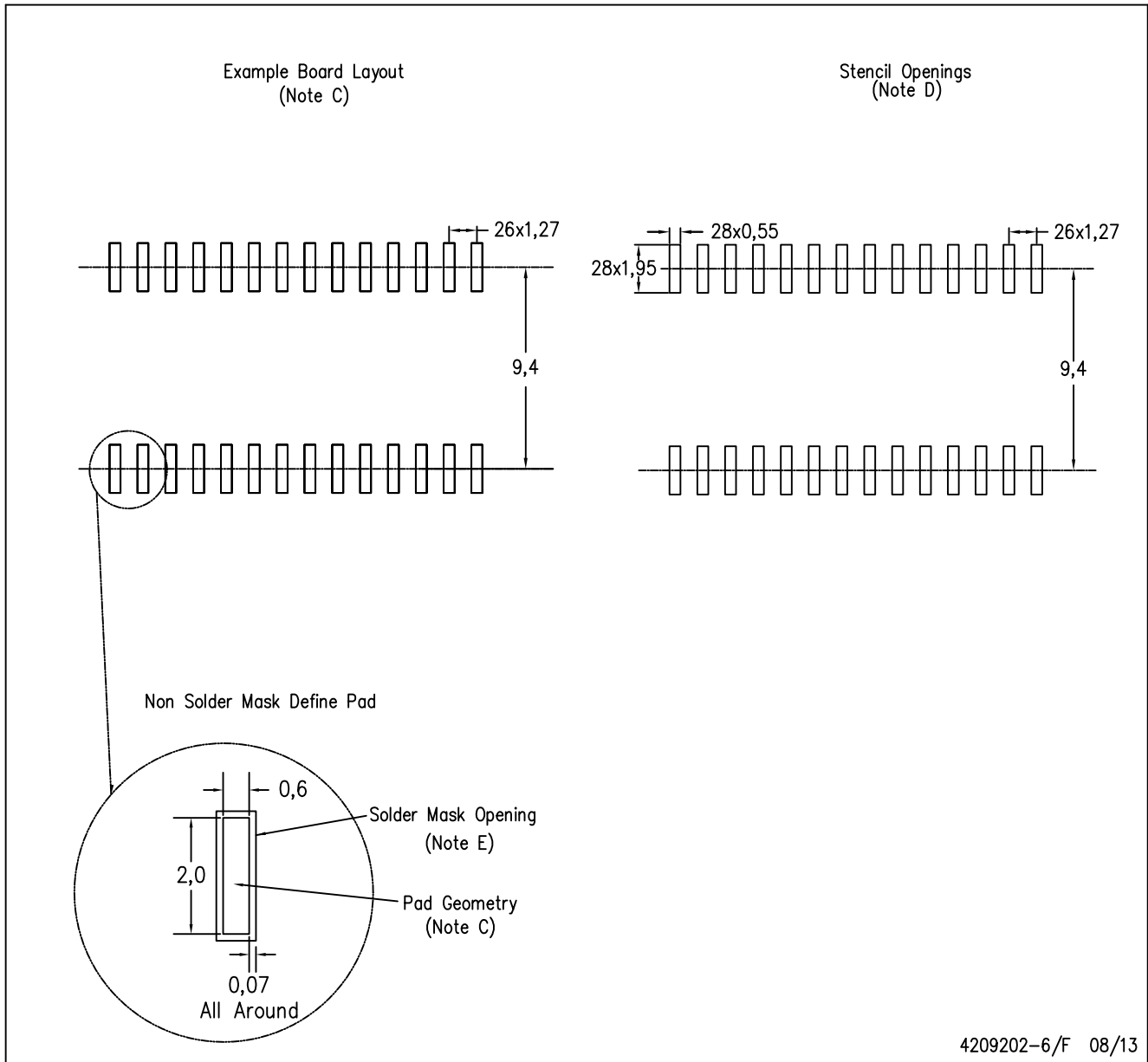

- NOTES:
- A. All linear dimensions are in millimeters.
  - B. This drawing is subject to change without notice.
  - C. Refer to IPC7351 for alternate board design.
  - D. Laser cutting apertures with trapezoidal walls and also rounding corners will offer better paste release. Customers should contact their board assembly site for stencil design recommendations. Refer to IPC-7525
  - E. Customers should contact their board fabrication site for solder mask tolerances between and around signal pads.



# MECHANICAL DATA

PW (R-PDSO-G28)

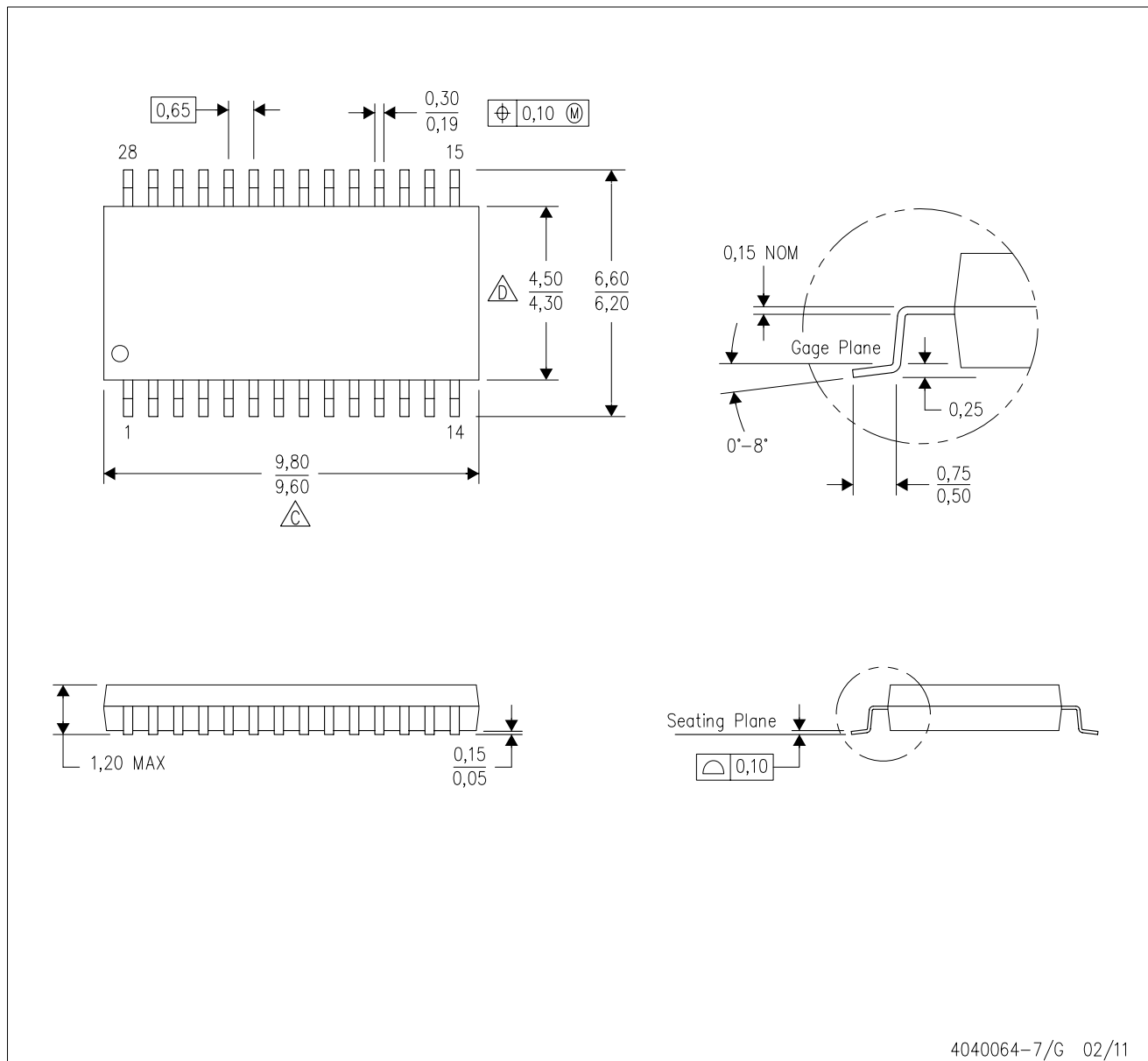
PLASTIC SMALL OUTLINE



4040064-7/G 02/11

- NOTES:
- A. All linear dimensions are in millimeters. Dimensioning and tolerancing per ASME Y14.5M-1994.
  - B. This drawing is subject to change without notice.
  -  C. Body length does not include mold flash, protrusions, or gate burrs. Mold flash, protrusions, or gate burrs shall not exceed 0,15 each side.
  -  D. Body width does not include interlead flash. Interlead flash shall not exceed 0,25 each side.
  - E. Falls within JEDEC MO-153

## 重要なお知らせと免責事項

TI は、技術データと信頼性データ (データシートを含みます)、設計リソース (リファレンス デザインを含みます)、アプリケーションや設計に関する各種アドバイス、Web ツール、安全性情報、その他のリソースを、欠陥が存在する可能性のある「現状のまま」提供しており、商品性および特定目的に対する適合性の黙示保証、第三者の知的財産権の非侵害保証を含むいかなる保証も、明示的または黙示的にかかわらず拒否します。

これらのリソースは、TI 製品を使用する設計の経験を積んだ開発者への提供を意図したものです。(1) お客様のアプリケーションに適した TI 製品の選定、(2) お客様のアプリケーションの設計、検証、試験、(3) お客様のアプリケーションに該当する各種規格や、その他のあらゆる安全性、セキュリティ、規制、または他の要件への確実な適合に関する責任を、お客様のみが単独で負うものとし、

上記の各種リソースは、予告なく変更される可能性があります。これらのリソースは、リソースで説明されている TI 製品を使用するアプリケーションの開発の目的でのみ、TI はその使用をお客様に許諾します。これらのリソースに関して、他の目的で複製することや掲載することは禁止されています。TI や第三者の知的財産権のライセンスが付与されている訳ではありません。お客様は、これらのリソースを自身で使用した結果発生するあらゆる申し立て、損害、費用、損失、責任について、TI およびその代理人を完全に補償するものとし、TI は一切の責任を拒否します。

TI の製品は、[TI の販売条件](#)、[TI の総合的な品質ガイドライン](#)、[ti.com](#) または TI 製品などに関連して提供される他の適用条件に従い提供されます。TI がこれらのリソースを提供することは、適用される TI の保証または他の保証の放棄の拡大や変更を意味するものではありません。TI がカスタム、またはカスタマー仕様として明示的に指定していない限り、TI の製品は標準的なカタログに掲載される汎用機器です。

お客様がいかなる追加条項または代替条項を提案する場合も、TI はそれらに異議を唱え、拒否します。

Copyright © 2026, Texas Instruments Incorporated

最終更新日 : 2025 年 10 月