

# OPAx187 0.001 $\mu$ V/ $^{\circ}$ Cドリフト、低消費電力、レール・ツー・レール出力、36Vオペアンプ、ゼロ・ドリフト・シリーズ

## 1 特長

- 低いオフセット電圧: 10 $\mu$ V (最大値)
- ゼロ・ドリフト: 0.001 $\mu$ V/ $^{\circ}$ C
- 低ノイズ: 15nV/ $\sqrt{\text{Hz}}$
- PSRR: 160dB
- CMRR: 140dB
- AOL: 160dB
- 静止電流: 100 $\mu$ A
- 広い電源電圧範囲:  $\pm$ 2.25V $\sim$  $\pm$ 18V
- レール・ツー・レール出力動作
- 入力に負のレールも含む
- 低いバイアス電流: 100pA (標準値)
- EMIフィルタ付き入力
- Microsizeパッケージ

## 2 アプリケーション

- ブリッジ・アンプ
- 歪みゲージ
- テストおよび計測機器
- トランスデューサ・アプリケーション
- 温度測定
- 電子計測器
- 医療用計測機器
- RTDアンプ
- 高精度アクティブ・フィルタ
- ローサイド電流監視

## 3 概要

OPAx187シリーズのオペアンプは、オートゼロ方式を採用して、低いオフセット電圧(1 $\mu$ V)と、時間や温度の変化に対してほぼゼロのドリフト係数を同時に実現しています。これらのアンプは小型、高精度で、静止電流が低く、入力インピーダンスが高く、高インピーダンスの負荷に対してレールの5mV以内のレール・ツー・レール出力を供給します。入力同相範囲には、負のレールも含まれます。4.5V $\sim$ 36Vの範囲( $\pm$ 2.25Vから $\pm$ 18Vまで)の単一電源またはデュアル電源を使用できます。

OPAx187 デバイスのシングル・バージョンは、Microsize 8ピン VSSOP、5ピン SOT-23、8ピン SOIC のパッケージで供給されます。デュアル・バージョンは、8ピン VSSOP および 8ピン SOIC のパッケージで供給されます。クワッド・バージョンは、14ピン SOIC、14ピン TSSOP、16ピン WQFNパッケージで供給されます。どのバージョンも、-40 $^{\circ}$ C $\sim$ +125 $^{\circ}$ Cでの動作が規定されています。

### 製品情報<sup>(1)</sup>

型番	パッケージ	本体サイズ(公称)
OPA187	SOIC (8)	4.90mm $\times$ 3.91mm
	SOT-23 (5)	2.90mm $\times$ 1.60mm
	VSSOP (8)	3.00mm $\times$ 3.00mm
OPA2187	SOIC (8)	4.90mm $\times$ 3.91mm
	VSSOP (8)	3.00mm $\times$ 3.00mm
OPA4187	SOIC (14)	8.70mm $\times$ 3.90mm
	TSSOP (14)	5.00mm $\times$ 4.40mm
	WQFN (16)(プレビュー)	4.00mm $\times$ 4.00mm

(1) 利用可能なすべてのパッケージについては、このデータシートの末尾にあるパッケージ・オプションについての付録を参照してください。

### OPAx187による高精度のローサイド電流測定

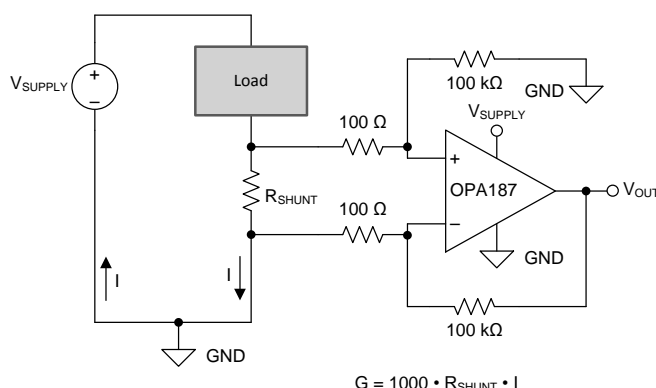

$$G = 1000 \cdot R_{\text{SHUNT}} \cdot I$$



## 目次

1	特長	1	7.4	Device Functional Modes	20
2	アプリケーション	1	<b>8</b>	<b>Application and Implementation</b>	<b>21</b>
3	概要	1	8.1	Application Information	21
4	改訂履歴	2	8.2	Typical Applications	21
<b>5</b>	<b>Pin Configuration and Functions</b>	<b>3</b>	<b>9</b>	<b>Power Supply Recommendations</b>	<b>25</b>
<b>6</b>	<b>Specifications</b>	<b>5</b>	<b>10</b>	<b>Layout</b>	<b>26</b>
6.1	Absolute Maximum Ratings	5	10.1	Layout Guidelines	26
6.2	ESD Ratings	5	10.2	Layout Example	26
6.3	Recommended Operating Conditions	5	<b>11</b>	デバイスおよびドキュメントのサポート	<b>27</b>
6.4	Thermal Information: OPA187	6	11.1	デバイス・サポート	27
6.5	Thermal Information: OPA2187	6	11.2	ドキュメントのサポート	27
6.6	Thermal Information: OPA4187	6	11.3	関連リンク	28
6.7	Electrical Characteristics: High-Voltage Operation	7	11.4	ドキュメントの更新通知を受け取る方法	28
6.8	Electrical Characteristics: Low-Voltage Operation	8	11.5	コミュニティ・リソース	28
6.9	Typical Characteristics	9	11.6	商標	28
<b>7</b>	<b>Detailed Description</b>	<b>16</b>	11.7	静電気放電に関する注意事項	28
7.1	Overview	16	11.8	Glossary	28
7.2	Functional Block Diagram	16	<b>12</b>	メカニカル、パッケージ、および注文情報	<b>28</b>
7.3	Feature Description	17			

## 4 改訂履歴

資料番号末尾の英字は改訂を表しています。その改訂履歴は英語版に準じています。

Revision C (December 2018) から Revision D に変更	Page
• OPA4187 の SOIC および TSSOP パッケージを製品プレビューから量産データに変更	1
• Changed offset drift (high and low supply) max to $\pm 15 \text{ nV}/^\circ\text{C}$	8

Revision B (October 2018) から Revision C に変更	Page
• 量産 OPA187 SOIC デバイスの最初のリリース	1

Revision A (July 2017) から Revision B に変更	Page
• OPA187 SOIC のステータスをプレビューに変更	1
• OPA4187 の SOIC、TSSOP、WQFN のステータスをプレビューに変更	1
• Changed offset drift (high supply) typical from $\pm 5 \text{ nV}/^\circ\text{C}$ to $\pm 1 \text{ nV}/^\circ\text{C}$ and max from $\pm 50 \text{ nV}/^\circ\text{C}$ to $\pm 20 \text{ nV}/^\circ\text{C}$	7
• Changed input bias current max (high supply) from $\pm 5 \text{ nA}$ to $\pm 7.5 \text{ nA}$	7
• Changed input offset current max (high supply) from $\pm 5 \text{ nA}$ to $\pm 14.5 \text{ nA}$	7
• Changed offset drift (low supply) typical from $\pm 5 \text{ nV}/^\circ\text{C}$ to $\pm 1 \text{ nV}/^\circ\text{C}$ and max from $\pm 50 \text{ nV}/^\circ\text{C}$ to $\pm 20 \text{ nV}/^\circ\text{C}$	8
• 変更 Offset Voltage Production Distribution figure	10

2016年12月発行のものから更新	Page
• 「概要」から VSON パッケージ・オプションを削除	1
• 「製品情報」表から VSON パッケージ・オプションを削除	1
• 「製品情報」表に WQFN パッケージ・オプションを追加	1
• Deleted OPA187 DRG package option from <i>Pin Configuration and Functions</i>	3
• Added WQFN package to <i>Pin Configuration and Functions</i>	4

## 5 Pin Configuration and Functions

**OPA187: DBV Package  
5-Pin SOT-23  
Top View**

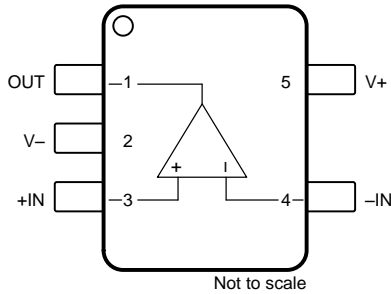

**OPA187: D and DGK Packages  
8-Pin SOIC and 8-pin VSSOP  
Top View**

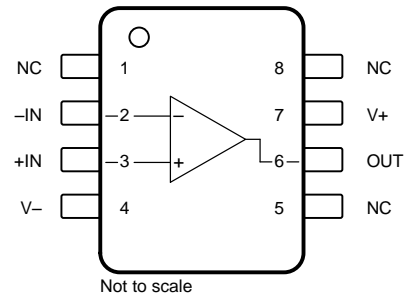

(1) NC denotes no internal connection.

### Pin Functions: OPA187

NAME	PIN		I/O	DESCRIPTION
	DBV	D and DGK		
+IN	3	3	I	Non-inverting input
-IN	4	2	I	Inverting input
NC	—	1, 5, 8	—	No connection (can be left floating)
OUT	1	6	O	Output signal
V+	5	7	—	Positive (highest) supply voltage
V-	2	4	—	Negative (lowest) supply voltage

**OPA2187: D and DGK Packages  
8-Pin SOIC and 8-Pin VSSOP  
Top View**

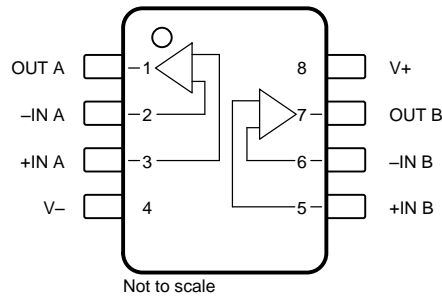

### Pin Functions: OPA2187

NAME	PIN		I/O	DESCRIPTION
	D and DGK			
+IN A	3		I	Non-inverting input, channel A
-IN A	2		I	Inverting input, channel A
+IN B	5		I	Non-inverting input, channel B
-IN B	6		I	Inverting input, channel B
OUT A	1		O	Output, channel A
OUT B	7		O	Output, channel B
V+	8		—	Positive (highest) supply voltage
V-	4		—	Negative (lowest) supply voltage

**OPA4187: D and PW Packages**  
**14-pin SOIC and 14-Pin TSSOP**  
**Top View**

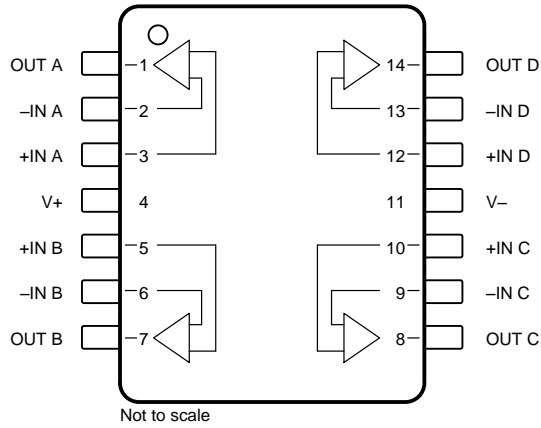

**OPA4187: RUM Package (Preview)**  
**16-pin WQFN**  
**Top View**

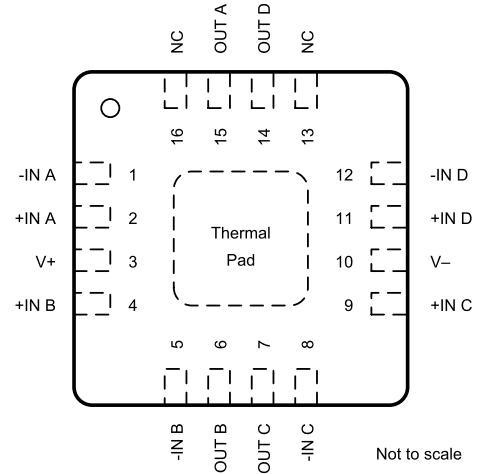

**Pin Functions: OPA4187**

NAME	PIN		I/O	DESCRIPTION
	D and PW	RUM		
+IN A	3	2	I	Non-inverting input, channel A
-IN A	2	1	I	Inverting input, channel A
+IN B	5	4	I	Non-inverting input, channel B
-IN B	6	5	I	Inverting input, channel B
+IN C	10	9	I	Non-inverting input, channel C
-IN C	9	8	I	Inverting input, channel C
+IN D	12	11	I	Non-inverting input, channel D
-IN D	13	12	I	Inverting input, channel D
OUT A	1	15	O	Output, channel A
OUT B	7	6	O	Output, channel B
OUT C	8	7	O	Output, channel C
OUT D	14	14	O	Output, channel D
V+	4	3	—	Positive (highest) supply voltage
V-	11	10	—	Negative (lowest) supply voltage
NC	—	13, 16	—	No internal connection (can be left floating)

## 6 Specifications

### 6.1 Absolute Maximum Ratings

over operating free-air temperature range (unless otherwise noted)<sup>(1)</sup>

		MIN	MAX	UNIT
Voltage	Supply, $V_S = (V^+) - (V^-)$		40	V
	Signal input pin <sup>(2)</sup>	$(V^-) - 0.5$	$(V^+) + 0.5$	
	Signal output pin <sup>(3)</sup>	$(V^-) - 0.5$	$(V^+) + 0.5$	
Current	Signal input pin <sup>(2)</sup>	-10	10	mA
	Signal output pin <sup>(3)</sup>	-55	55	mA
	Output short-circuit <sup>(4)</sup>	Continuous	Continuous	Continuous
Temperature	Operating range, $T_A$	-55	150	°C
	Junction, $T_J$		150	
	Storage, $T_{stg}$	-65	150	

- (1) Stresses beyond those listed under *Absolute Maximum Ratings* may cause permanent damage to the device. These are stress ratings only, which do not imply functional operation of the device at these or any other conditions beyond those indicated under *Recommended Operating Conditions*. Exposure to absolute-maximum-rated conditions for extended periods may affect device reliability.
- (2) Input terminals are diode-clamped to the power-supply rails. Input signals that can swing more than 0.5 V beyond the supply rails should be current limited to  $\pm 10$  mA or less.
- (3) Output terminals are diode-clamped to the power-supply rails. Output signals that can swing more than 0.5 V beyond the supply rails should be current limited to  $\pm 55$  mA or less.
- (4) Short-circuit to ground, one amplifier per package.

### 6.2 ESD Ratings

			VALUE	UNIT
$V_{(ESD)}$	Electrostatic discharge	Human-body model (HBM), per ANSI/ESDA/JEDEC JS-001 <sup>(1)</sup>	$\pm 4000$	V
		Charged-device model (CDM), per JEDEC specification JESD22-C101 <sup>(2)</sup>	$\pm 1500$	

- (1) JEDEC document JEP155 states that 500-V HBM allows safe manufacturing with a standard ESD control process.
- (2) JEDEC document JEP157 states that 250-V CDM allows safe manufacturing with a standard ESD control process.

### 6.3 Recommended Operating Conditions

over operating free-air temperature range (unless otherwise noted)

		MIN	NOM	MAX	UNIT
$(V^+) - (V^-)$	Supply voltage	4.5 ( $\pm 2.25$ )		36 ( $\pm 18$ )	V
$T_A$	Operating temperature	-40		150	°C

#### 6.4 Thermal Information: OPA187

THERMAL METRIC <sup>(1)</sup>		OPA187			UNIT
		5 PINS	8 PINS		
		DBV (SOT-23)	DGK (VSSOP)	D (SOIC)	
$R_{\theta JA}$	Junction-to-ambient thermal resistance	273.8	159	100.1	°C/W
$R_{\theta JC(top)}$	Junction-to-case (top) thermal resistance	126.8	37	42.4	°C/W
$R_{\theta JB}$	Junction-to-board thermal resistance	85.9	49	41.0	°C/W
$\Psi_{JT}$	Junction-to-top characterization parameter	10.9	1.2	4.8	°C/W
$\Psi_{JB}$	Junction-to-board characterization parameter	84.9	77.1	40.3	°C/W
$R_{\theta JC(bot)}$	Junction-to-case (bottom) thermal resistance	n/a	n/a	n/a	°C/W

(1) For more information about traditional and new thermal metrics, see the [Semiconductor and IC Package Thermal Metrics](#) application report.

#### 6.5 Thermal Information: OPA2187

THERMAL METRIC <sup>(1)</sup>		OPA2187		UNIT
		8 PINS		
		DGK (VSSOP)	D (SOIC)	
$R_{\theta JA}$	Junction-to-ambient thermal resistance	159	100.1	°C/W
$R_{\theta JC(top)}$	Junction-to-case (top) thermal resistance	37	42.4	°C/W
$R_{\theta JB}$	Junction-to-board thermal resistance	49	41.0	°C/W
$\Psi_{JT}$	Junction-to-top characterization parameter	1.2	4.8	°C/W
$\Psi_{JB}$	Junction-to-board characterization parameter	77.1	40.3	°C/W
$R_{\theta JC(bot)}$	Junction-to-case (bottom) thermal resistance	n/a	n/a	°C/W

(1) For more information about traditional and new thermal metrics, see the [Semiconductor and IC Package Thermal Metrics](#) application report.

#### 6.6 Thermal Information: OPA4187

THERMAL METRIC <sup>(1)</sup>		OPA4187			UNIT
		14 PINS		16 PINS	
		PW (TSSOP)	D (SOIC)	RUM (WQFN)	
$R_{\theta JA}$	Junction-to-ambient thermal resistance	107.8	83.8	35.3	°C/W
$R_{\theta JC(top)}$	Junction-to-case (top) thermal resistance	29.6	70.7	32.7	°C/W
$R_{\theta JB}$	Junction-to-board thermal resistance	52.6	59.5	12.9	°C/W
$\Psi_{JT}$	Junction-to-top characterization parameter	1.5	11.6	0.3	°C/W
$\Psi_{JB}$	Junction-to-board characterization parameter	51.6	37.7	12.9	°C/W
$R_{\theta JC(bot)}$	Junction-to-case (bottom) thermal resistance	n/a	n/a	3.3	°C/W

(1) For more information about traditional and new thermal metrics, see the [Semiconductor and IC Package Thermal Metrics](#) application report.

## 6.7 Electrical Characteristics: High-Voltage Operation

at  $T_A = +25^\circ\text{C}$ ,  $V_S = \pm 4\text{ V}$  to  $\pm 18\text{ V}$  ( $V_S = +8\text{ V}$  to  $+36\text{ V}$ ),  $R_L = 10\text{ k}\Omega$  connected to  $V_S / 2^{(1)}$ , and  $V_{CM} = V_{OUT} = V_S / 2^{(1)}$  (unless otherwise noted)

PARAMETER		CONDITIONS	MIN	TYP	MAX	UNIT
<b>OFFSET VOLTAGE</b>						
$V_{OS}$	Input offset voltage			$\pm 1$	$\pm 10$	$\mu\text{V}$
		$T_A = -40^\circ\text{C}$ to $+125^\circ\text{C}$		$\pm 0.001$	$\pm 0.015$	$\mu\text{V}/^\circ\text{C}$
PSRR	Power-supply rejection ratio	$V_S = 4.5\text{ V}$ to $36\text{ V}$ , $T_A = -40^\circ\text{C}$ to $+125^\circ\text{C}$		$\pm 0.01$	$\pm 1$	$\mu\text{V}/\text{V}$
<b>INPUT BIAS CURRENT</b>						
$I_B$	Input bias current	$V_{CM} = V_S / 2$		$\pm 100$	$\pm 350$	$\text{pA}$
		$T_A = -40^\circ\text{C}$ to $+125^\circ\text{C}$			$\pm 7.5$	$\text{nA}$
$I_{OS}$	Input offset current			$\pm 100$	$\pm 500$	$\text{pA}$
		$T_A = -40^\circ\text{C}$ to $+125^\circ\text{C}$			$\pm 14.5$	$\text{nA}$
<b>NOISE</b>						
$e_n$	Input voltage noise	$f = 0.1\text{ Hz}$ to $10\text{ Hz}$		0.4		$\mu\text{V}_{PP}$
		$f = 0.1\text{ Hz}$ to $10\text{ Hz}$		60		$\text{nV}_{RMS}$
	Input voltage noise density	$f = 1\text{ kHz}$		20		$\text{nV}/\sqrt{\text{Hz}}$
$i_n$	Input current noise density	$f = 1\text{ kHz}$		160		$\text{fA}/\sqrt{\text{Hz}}$
<b>INPUT VOLTAGE RANGE</b>						
$V_{CM}$	Common-mode voltage range		$(V-) - 0.1$		$(V+) - 2$	$\text{V}$
CMRR	Common-mode rejection ratio	$(V-) - 0.1\text{ V} < V_{CM} < (V+) - 2\text{ V}$ , $V_S = \pm 18\text{ V}$	126	140		$\text{dB}$
		$(V-) < V_{CM} < (V+) - 2\text{ V}$ , $V_S = \pm 18\text{ V}$ , $T_A = -40^\circ\text{C}$ to $+125^\circ\text{C}$	130	145		$\text{dB}$
<b>INPUT IMPEDANCE</b>						
$Z_{ID}$	Differential			$100 \parallel 6$		$\text{M}\Omega \parallel \text{pF}$
$Z_{IC}$	Common-mode			$6 \parallel 4.2$		$10^{12}\ \Omega \parallel \text{pF}$
<b>OPEN-LOOP GAIN</b>						
$A_{OL}$	Open-loop voltage gain	$T_A = -40^\circ\text{C}$ to $+125^\circ\text{C}$ , $V_S = \pm 4\text{ V}$ to $\pm 18\text{ V}$ , $(V-) + 0.3\text{ V} < V_O < (V+) - 0.3\text{ V}$ , $R_L = 10\text{ k}\Omega$	132	160		$\text{dB}$
<b>FREQUENCY RESPONSE</b>						
GBW	Gain-bandwidth product			550		$\text{kHz}$
SR	Slew rate	$V_O = 10\text{-V}$ step, $G = +1$		0.2		$\text{V}/\mu\text{s}$
$t_S$	Settling time	0.1%	$V_S = \pm 18\text{ V}$ , $G = 1$ , $10\text{-V}$ step	46		$\mu\text{s}$
		0.01%	$V_S = \pm 18\text{ V}$ , $G = 1$ , $10\text{-V}$ step	48		$\mu\text{s}$
$t_{OR}$	Overload recovery time	$V_{IN} \times G = V_S$		8		$\mu\text{s}$
THD+N	Total harmonic distortion + noise	1 kHz, $G = +1$ , $V_{OUT} = 3.5\text{ V}_{RMS}$ , No Load		0.035%		
<b>OUTPUT</b>						
	Voltage output swing from rail	$V_S = \pm 4\text{ V}$ to $\pm 18\text{ V}$ , No Load		5	15	$\text{mV}$
		$V_S = \pm 4\text{ V}$ to $\pm 18\text{ V}$ , $R_L = 10\text{ k}\Omega$		75	100	
		$V_S = \pm 4\text{ V}$ to $\pm 18\text{ V}$ , $R_L = 10\text{ k}\Omega$ , $T_A = -40^\circ\text{C}$ to $+125^\circ\text{C}$		100	125	
$I_{SC}$	Short-circuit current	$V_S = \pm 18\text{ V}$ , Sinking		-30		$\text{mA}$
		$V_S = \pm 18\text{ V}$ , Sourcing		+30		$\text{mA}$
$R_O$	Open-loop output resistance	$f = 550\text{ kHz}$ , $I_O = 0$ , See <a href="#">Figure 21</a>		1.4		$\text{k}\Omega$
$C_{LOAD}$	Capacitive load drive					See <a href="#">Typical Characteristics</a>
<b>POWER SUPPLY</b>						
$I_Q$	Quiescent current (per amplifier)	$V_S = \pm 4\text{ V}$ to $V_S = \pm 18\text{ V}$		100	145	$\mu\text{A}$
		$I_O = 0\text{ mA}$ , $T_A = -40^\circ\text{C}$ to $+125^\circ\text{C}$				150

(1)  $V_S / 2 = \text{midsupply}$ .

## 6.8 Electrical Characteristics: Low-Voltage Operation

at  $T_A = +25^\circ\text{C}$ ,  $V_S = \pm 2.25\text{ V}$  to  $\pm 4\text{ V}$  ( $V_S = +4.5\text{ V}$  to  $< +8\text{ V}$ ),  $R_L = 10\text{ k}\Omega$  connected to  $V_S / 2^{(1)}$ , and  $V_{CM} = V_{OUT} = V_S / 2^{(1)}$  (unless otherwise noted)

PARAMETER		CONDITIONS	MIN	TYP	MAX	UNIT
<b>OFFSET VOLTAGE</b>						
$V_{OS}$	Input offset voltage			$\pm 1$	$\pm 15$	$\mu\text{V}$
		$T_A = -40^\circ\text{C}$ to $+125^\circ\text{C}$		$\pm 0.001$	$\pm 0.015$	$\mu\text{V}/^\circ\text{C}$
PSRR	Power-supply rejection ratio	$V_S = 4.5\text{ V}$ to $36\text{ V}$ , $T_A = -40^\circ\text{C}$ to $+125^\circ\text{C}$		$\pm 0.01$	$\pm 1$	$\mu\text{V}/\text{V}$
<b>INPUT BIAS CURRENT</b>						
$I_B$	Input bias current	$V_{CM} = V_S / 2$		$\pm 100$	$\pm 350$	$\text{pA}$
		$T_A = -40^\circ\text{C}$ to $+125^\circ\text{C}$			$\pm 5$	$\text{nA}$
$I_{OS}$	Input offset current			$\pm 100$	$\pm 500$	$\text{pA}$
		$T_A = -40^\circ\text{C}$ to $+125^\circ\text{C}$			$\pm 5$	$\text{nA}$
<b>NOISE</b>						
$e_n$	Input voltage noise	$f = 0.1\text{ Hz}$ to $10\text{ Hz}$		0.4		$\mu\text{V}_{PP}$
		$f = 0.1\text{ Hz}$ to $10\text{ Hz}$		60		$\text{nV}_{rms}$
	Input voltage noise density	$f = 1\text{ kHz}$		20		$\text{nV}/\sqrt{\text{Hz}}$
$i_n$	Input current noise density	$f = 1\text{ kHz}$		160		$\text{fA}/\sqrt{\text{Hz}}$
<b>INPUT VOLTAGE RANGE</b>						
$V_{CM}$	Common-mode voltage range		$(V-) - 0.1$		$(V+) - 2$	$\text{V}$
CMRR	Common-mode rejection ratio	$(V-) - 0.1\text{ V} < V_{CM} < (V+) - 2\text{ V}$ , $V_S = \pm 2.25\text{ V}$	114	130		$\text{dB}$
		$(V-) < V_{CM} < (V+) - 2\text{ V}$ , $V_S = \pm 2.25\text{ V}$ , $T_A = -40^\circ\text{C}$ to $+125^\circ\text{C}$	120	137		$\text{dB}$
<b>INPUT IMPEDANCE</b>						
$Z_{ID}$	Differential			$100 \parallel 6$		$\text{M}\Omega \parallel \text{pF}$
$Z_{IC}$	Common-mode			$6 \parallel 4.2$		$10^{12}\ \Omega \parallel \text{pF}$
<b>OPEN-LOOP GAIN</b>						
$A_{OL}$	Open-loop voltage gain	$T_A = -40^\circ\text{C}$ to $+125^\circ\text{C}$ , $V_S = \pm 2.25\text{ V}$ to $\pm 4\text{ V}$ , $(V-) + 0.3\text{ V} < V_O < (V+) - 0.3\text{ V}$ , $R_L = 10\text{ k}\Omega$	120	140		$\text{dB}$
<b>FREQUENCY RESPONSE</b>						
GBW	Gain-bandwidth product			550		$\text{kHz}$
SR	Slew rate	$V_O = 1\text{-V}$ step, $G = +1$		0.2		$\text{V}/\mu\text{s}$
$t_{OR}$	Overload recovery time	$V_{IN} \times G = V_S$		8		$\mu\text{s}$
THD+N	Total harmonic distortion + noise	1 kHz, $G = +1$ , $V_{OUT} = 1\text{ V}_{rms}$ , No Load		0.05%		
<b>OUTPUT</b>						
	Voltage output swing from rail	$V_S = \pm 2.25\text{ V}$ to $\pm 4\text{ V}$ , No Load		5	15	$\text{mV}$
		$V_S = \pm 2.25\text{ V}$ to $\pm 4\text{ V}$ , $R_L = 10\text{ k}\Omega$		15	25	
		$V_S = \pm 2.25\text{ V}$ to $\pm 4\text{ V}$ , $R_L = 10\text{ k}\Omega$ , $T_A = -40^\circ\text{C}$ to $+125^\circ\text{C}$		15	30	
$I_{SC}$	Short-circuit current	$V_S = \pm 2.25$ , Sinking		-20		$\text{mA}$
		$V_S = \pm 2.25$ , Sourcing		+20		$\text{mA}$
$R_O$	Open-loop output resistance	$f = 550\text{ kHz}$ , $I_O = 0$ , See <a href="#">Figure 21</a>		1.4		$\text{k}\Omega$
$C_{LOAD}$	Capacitive load drive					See <a href="#">Typical Characteristics</a>
<b>POWER SUPPLY</b>						
$I_Q$	Quiescent current (per amplifier)	$V_S = \pm 2.25\text{ V}$ to $V_S = \pm 4\text{ V}$		100	145	$\mu\text{A}$
		$I_O = 0\text{ mA}$ , $T_A = -40^\circ\text{C}$ to $+125^\circ\text{C}$				150

(1)  $V_S / 2 = \text{midsupply}$ .

## 6.9 Typical Characteristics

**表 1. Typical Characteristic Graphs**

DESCRIPTION	FIGURE
Offset Voltage Production Distribution	<a href="#">图 1</a>
Offset Voltage Drift Distribution	<a href="#">图 2</a>
Offset Voltage vs Temperature	<a href="#">图 3</a>
Offset Voltage vs Common-Mode Voltage	<a href="#">图 4</a>
Offset Voltage vs Power Supply	<a href="#">图 5</a>
Open-Loop Gain and Phase vs Frequency	<a href="#">图 6</a>
Closed-Loop Gain vs Frequency	<a href="#">图 7</a>
$I_B$ vs Common-Mode Voltage	<a href="#">图 8</a>
Input Bias Current vs Temperature	<a href="#">图 9</a>
Output Voltage Swing vs Output Current	<a href="#">图 10</a>
CMRR and PSRR vs Frequency (Referred-to-Input)	<a href="#">图 11</a>
CMRR vs Temperature	<a href="#">图 12</a>
PSRR vs Temperature	<a href="#">图 13</a>
0.1-Hz to 10-Hz Noise	<a href="#">图 14</a>
Input Voltage Noise Spectral Density vs Frequency	<a href="#">图 15</a>
THD+N Ratio vs Frequency	<a href="#">图 16</a>
THD+N vs Output Amplitude	<a href="#">图 17</a>
Quiescent Current vs Supply Voltage	<a href="#">图 18</a>
Quiescent Current vs Temperature	<a href="#">图 19</a>
Open-Loop Gain vs Temperature	<a href="#">图 20</a>
Open-Loop Output Impedance vs Frequency	<a href="#">图 21</a>
Small-Signal Overshoot vs Capacitive Load ( $G = 1$ ) (10-mV Output Step)	<a href="#">图 22</a>
No Phase Reversal	<a href="#">图 23</a>
Positive Overload Recovery	<a href="#">图 24</a>
Negative Overload Recovery	<a href="#">图 25</a>
Small-Signal Step Response (10 mV)	<a href="#">图 26</a> , <a href="#">图 27</a>
Large-Signal Step Response	<a href="#">图 28</a> , <a href="#">图 29</a>
Large-Signal Settling Time (10-V Positive Step)	<a href="#">图 30</a>
Large-Signal Settling Time (10-V Negative Step)	<a href="#">图 31</a>
Short-Circuit Current vs Temperature	<a href="#">图 32</a>
Maximum Output Voltage vs Frequency	<a href="#">图 33</a>
Crosstalk vs Frequency	<a href="#">图 34</a>
EMIRR IN+ vs Frequency	<a href="#">图 35</a>

at  $V_S = \pm 18\text{ V}$ ,  $V_{CM} = V_S / 2$ ,  $R_{LOAD} = 10\text{ k}\Omega$  connected to  $V_S / 2$ , and  $C_L = 100\text{ pF}$  (unless otherwise noted)

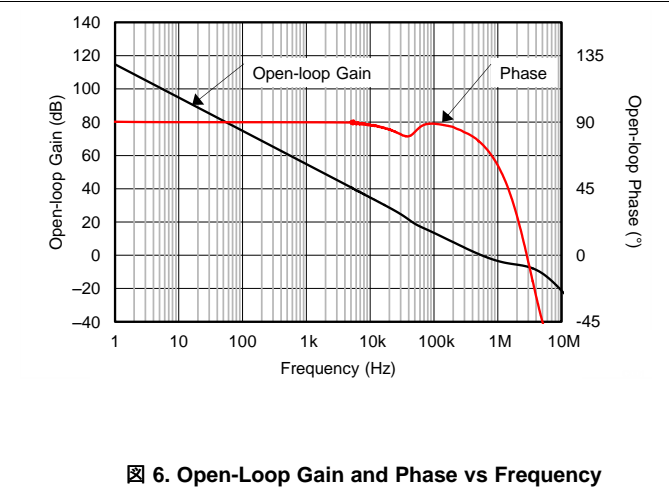
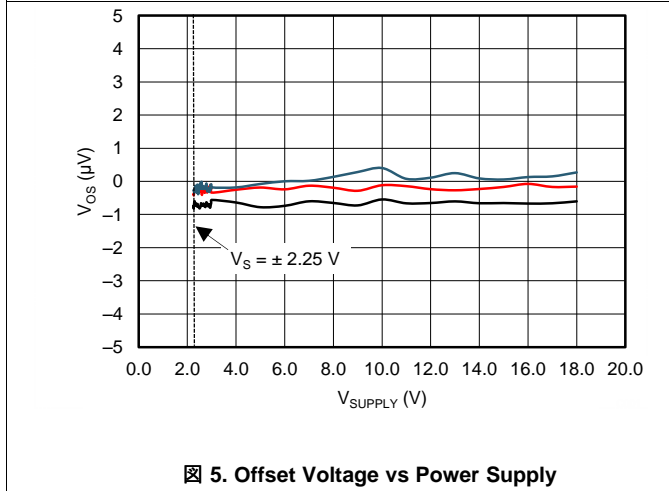
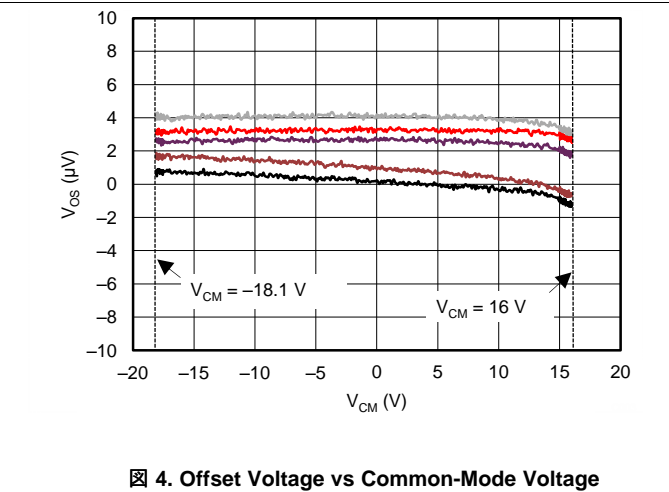
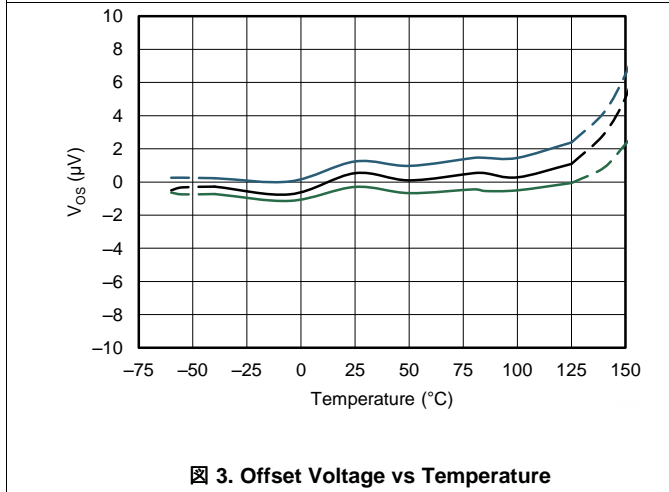
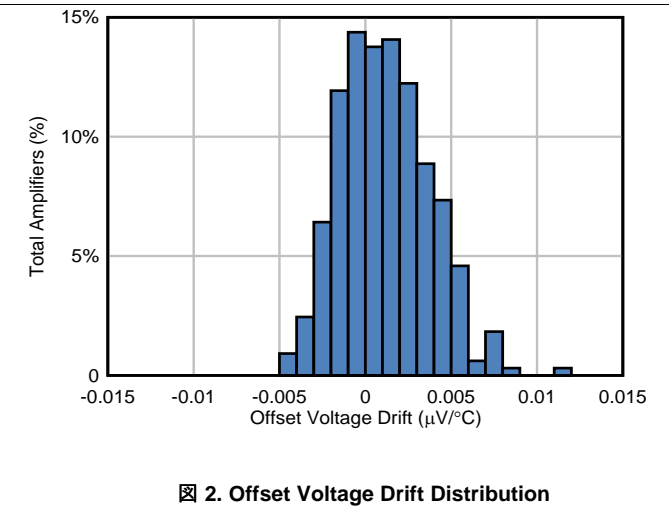
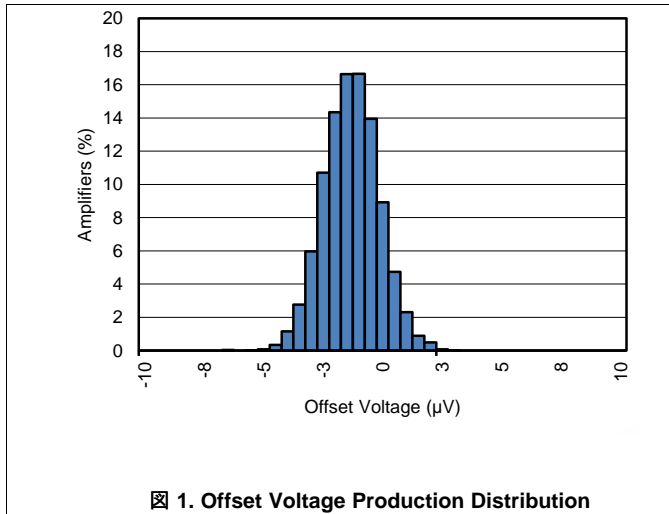

at  $V_S = \pm 18\text{ V}$ ,  $V_{CM} = V_S / 2$ ,  $R_{LOAD} = 10\text{ k}\Omega$  connected to  $V_S / 2$ , and  $C_L = 100\text{ pF}$  (unless otherwise noted)

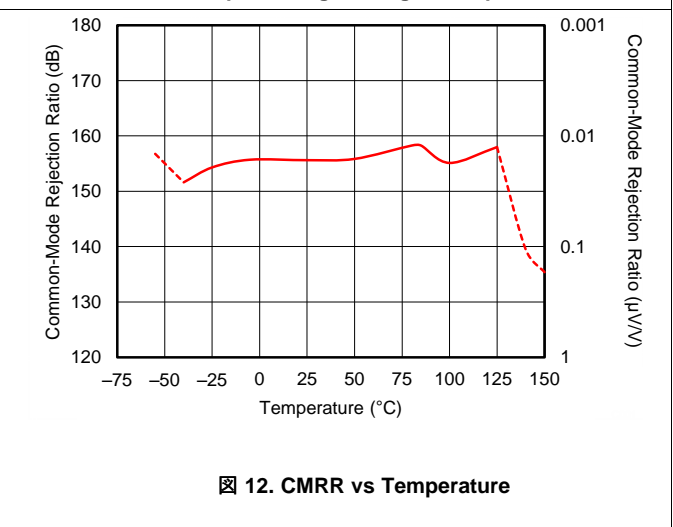
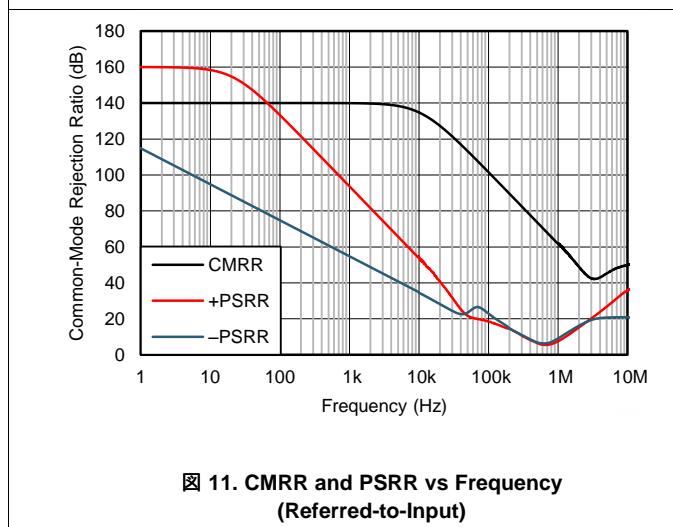
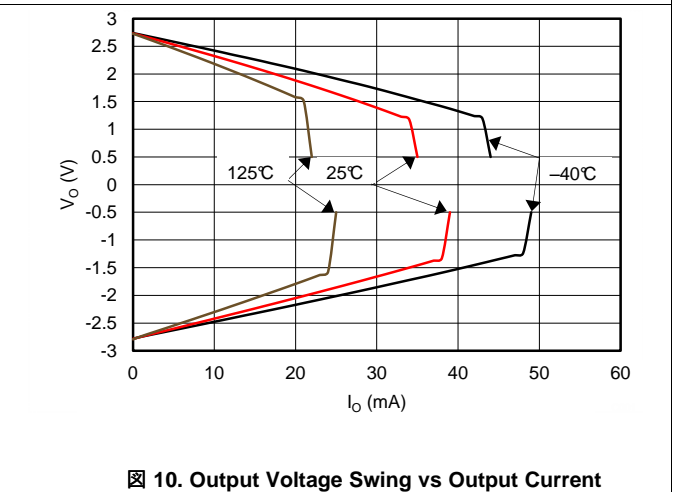
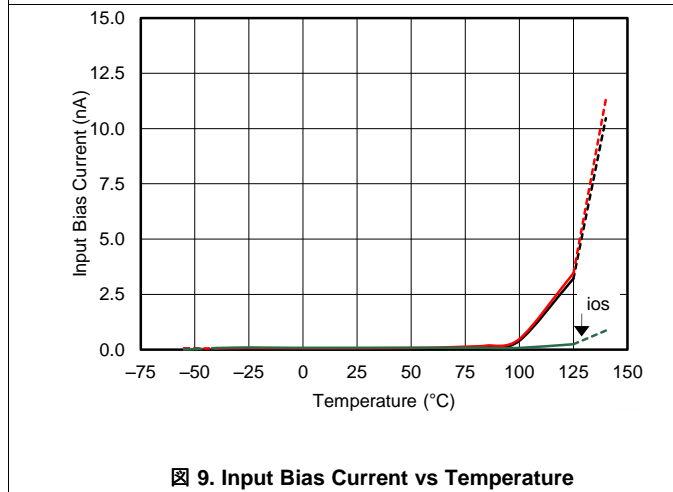
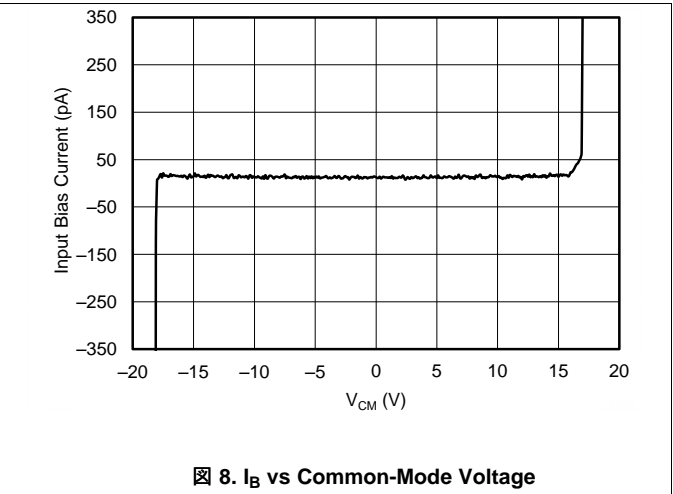
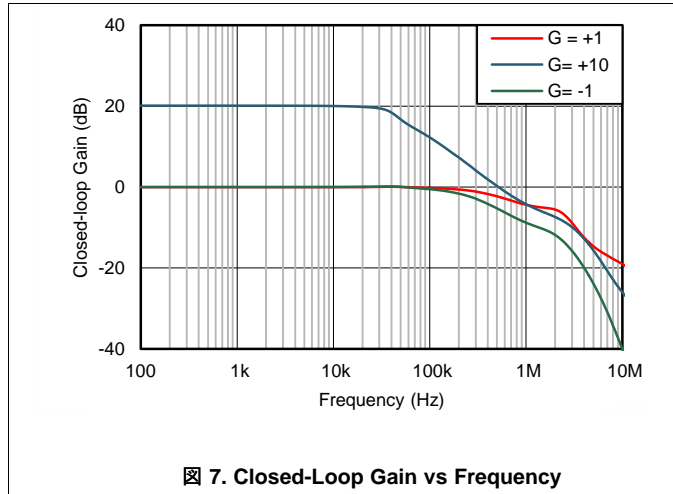

at  $V_S = \pm 18\text{ V}$ ,  $V_{CM} = V_S / 2$ ,  $R_{LOAD} = 10\text{ k}\Omega$  connected to  $V_S / 2$ , and  $C_L = 100\text{ pF}$  (unless otherwise noted)

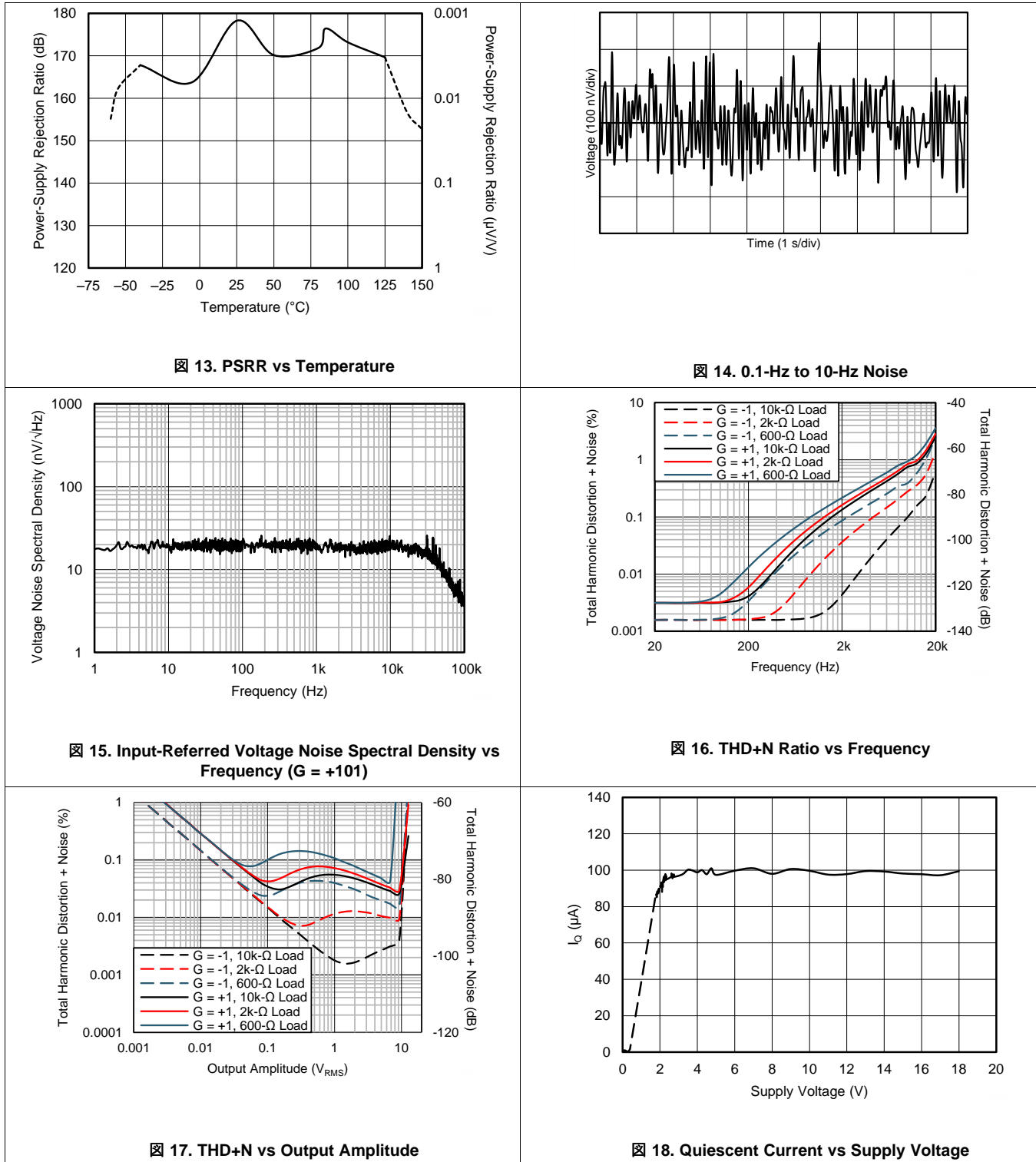

at  $V_S = \pm 18\text{ V}$ ,  $V_{CM} = V_S / 2$ ,  $R_{LOAD} = 10\text{ k}\Omega$  connected to  $V_S / 2$ , and  $C_L = 100\text{ pF}$  (unless otherwise noted)

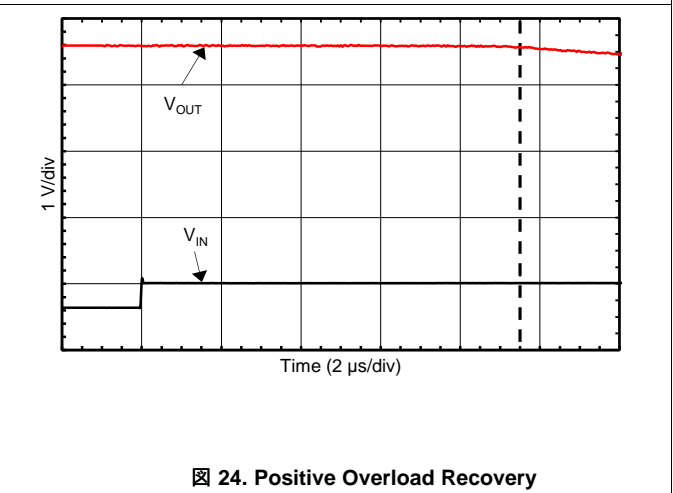
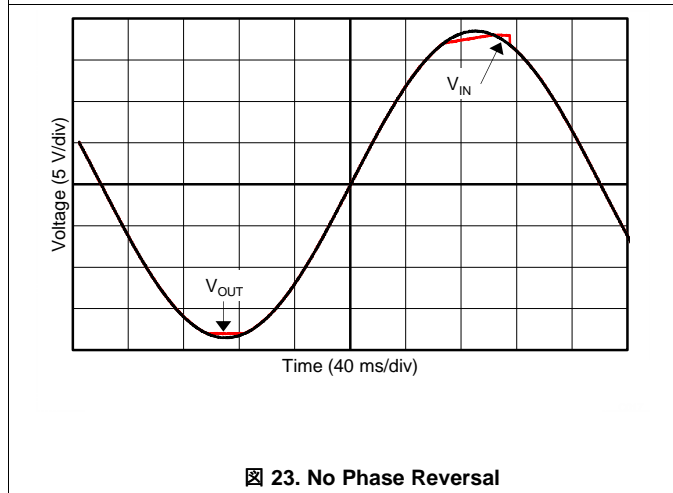
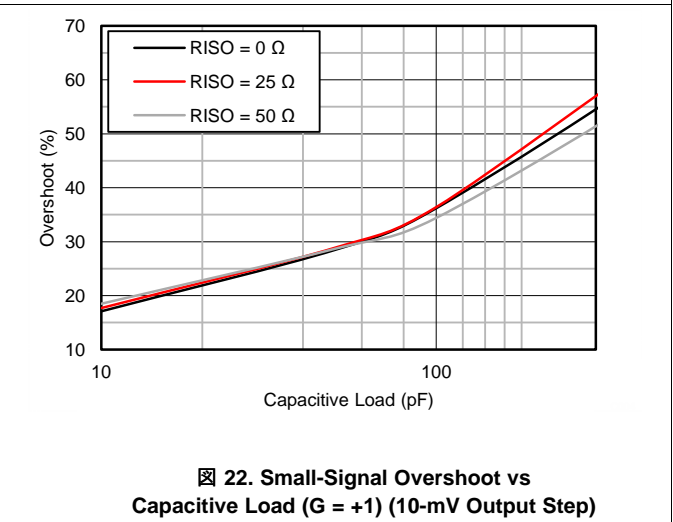
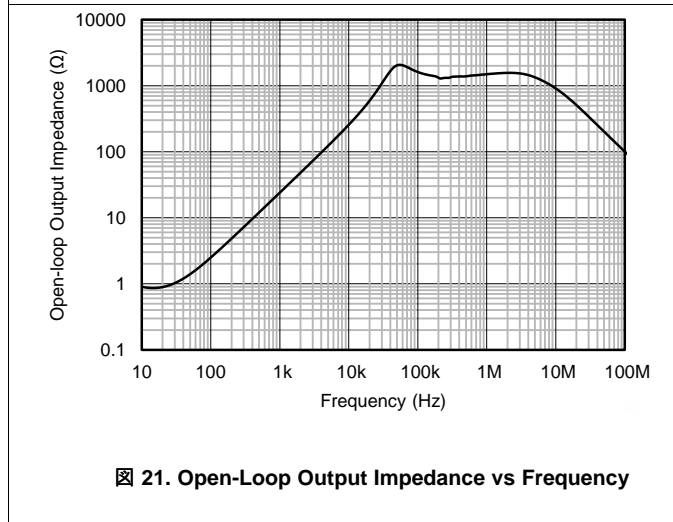
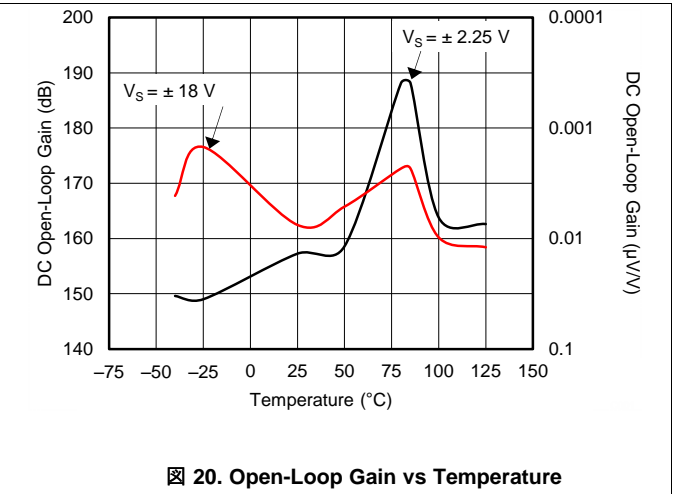
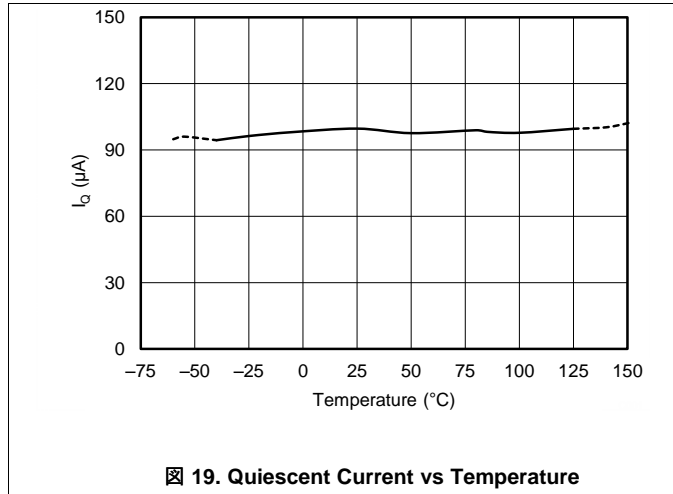

at  $V_S = \pm 18\text{ V}$ ,  $V_{CM} = V_S / 2$ ,  $R_{LOAD} = 10\text{ k}\Omega$  connected to  $V_S / 2$ , and  $C_L = 100\text{ pF}$  (unless otherwise noted)

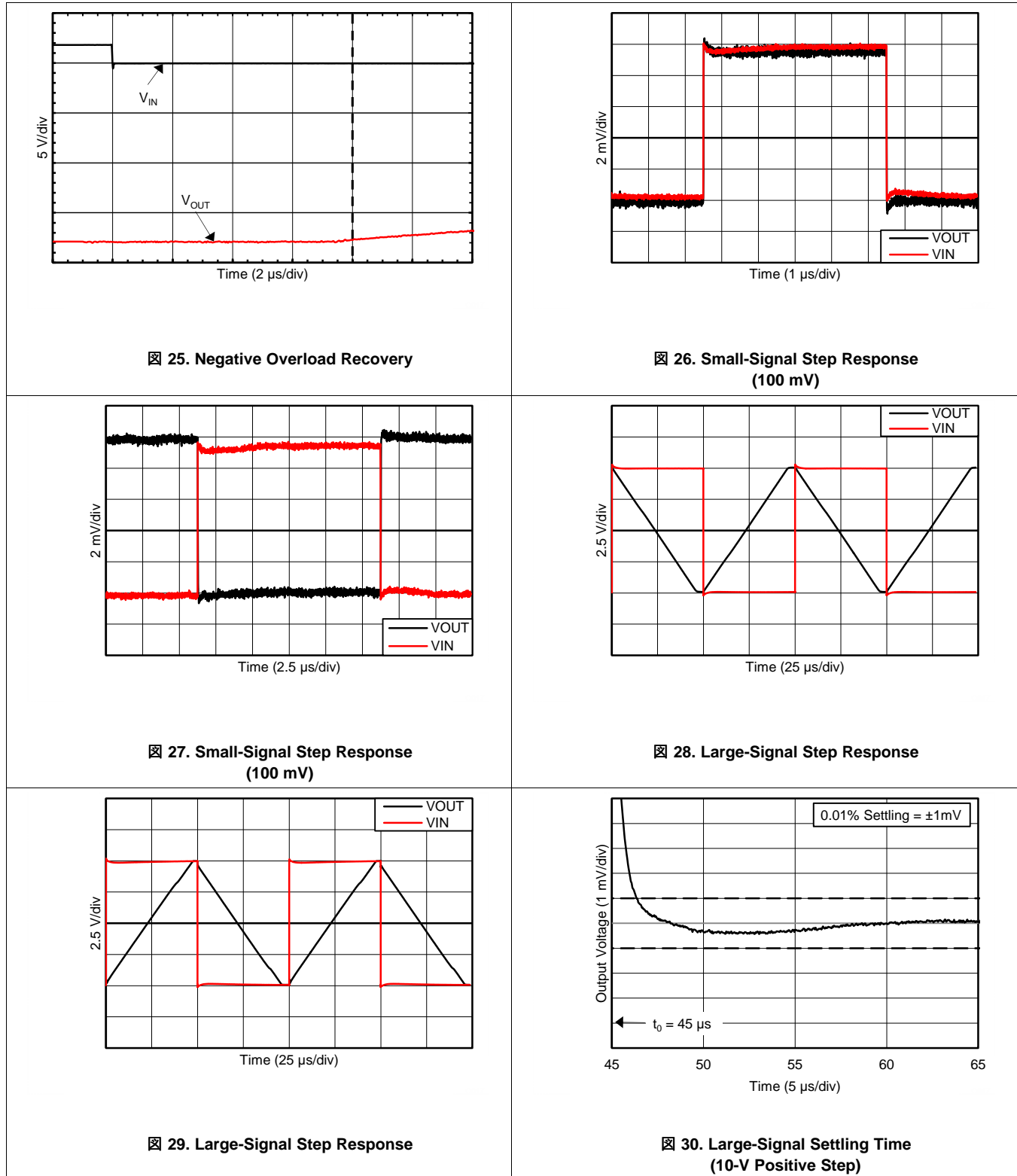

at  $V_S = \pm 18\text{ V}$ ,  $V_{CM} = V_S / 2$ ,  $R_{LOAD} = 10\text{ k}\Omega$  connected to  $V_S / 2$ , and  $C_L = 100\text{ pF}$  (unless otherwise noted)

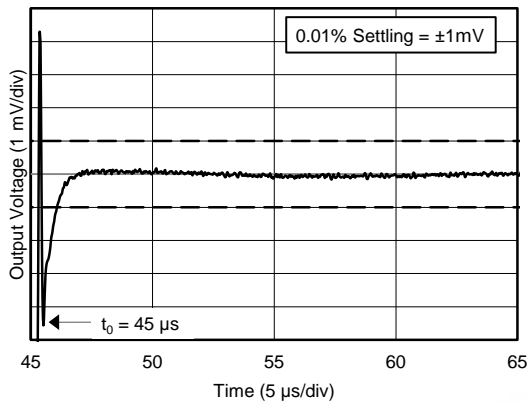

31. Large-Signal Settling Time (10-V Negative Step)

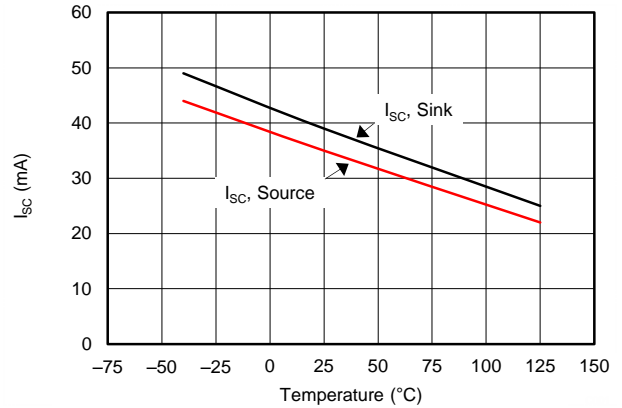

32. Short-Circuit Current vs Temperature

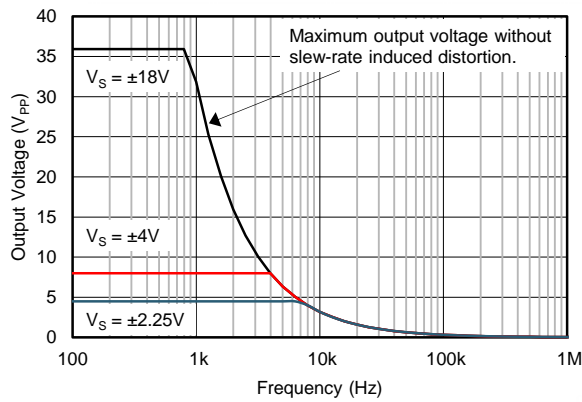

33. Maximum Output Voltage vs Frequency

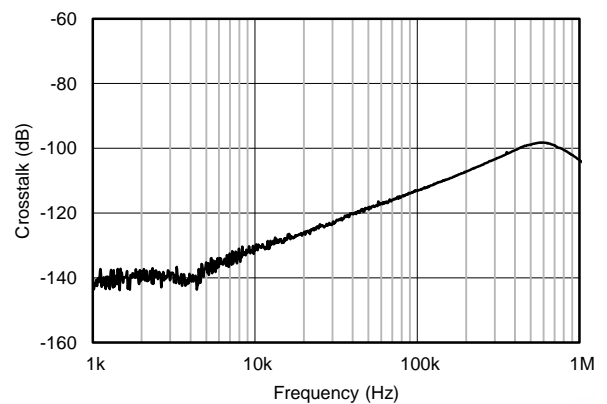

34. Crosstalk vs Frequency

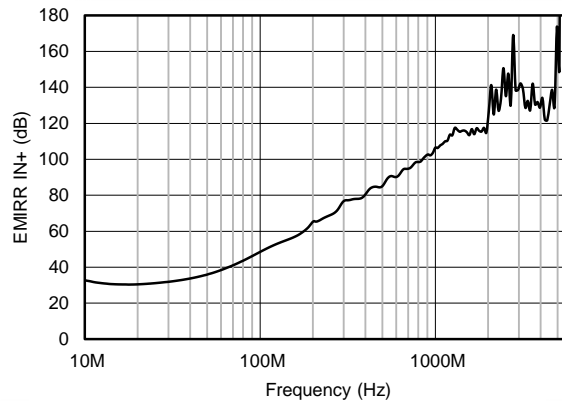

35. EMIRR IN+ vs Frequency

## 7 Detailed Description

### 7.1 Overview

The OPAx187 operational amplifier combines precision offset and drift with excellent overall performance, making the device ideal for many precision applications. The precision offset drift of only  $0.001 \mu\text{V}/^\circ\text{C}$  provides stability over the entire temperature range. In addition, this device offers excellent overall performance with high CMRR, PSRR, and  $A_{OL}$ . As with all amplifiers, applications with noisy or high-impedance power supplies require decoupling capacitors close to the device pins. In most cases,  $0.1\text{-}\mu\text{F}$  capacitors are adequate.

The OPAx187 device is part of a family of zero-drift, low-power, rail-to-rail output operational amplifiers. These devices operate from  $4.5\text{ V}$  to  $36\text{ V}$ , are unity-gain stable, and are suitable for a wide range of general-purpose applications. The zero-drift architecture provides ultra-low input offset voltage and near-zero input offset voltage drift over temperature and time. This choice of architecture also offers outstanding ac performance, such as ultra-low broadband noise and zero flicker noise.

### 7.2 Functional Block Diagram

Figure 36 shows a representation of the proprietary OPAx187 architecture. Functional blocks CHOP1 and CHOP2 operate such that the non-idealities of GM1 are cancelled while the input signal is left in-phase. The integrated notch filter of the OPAx187 family suppresses most of the auto-zero amplifier carrier.

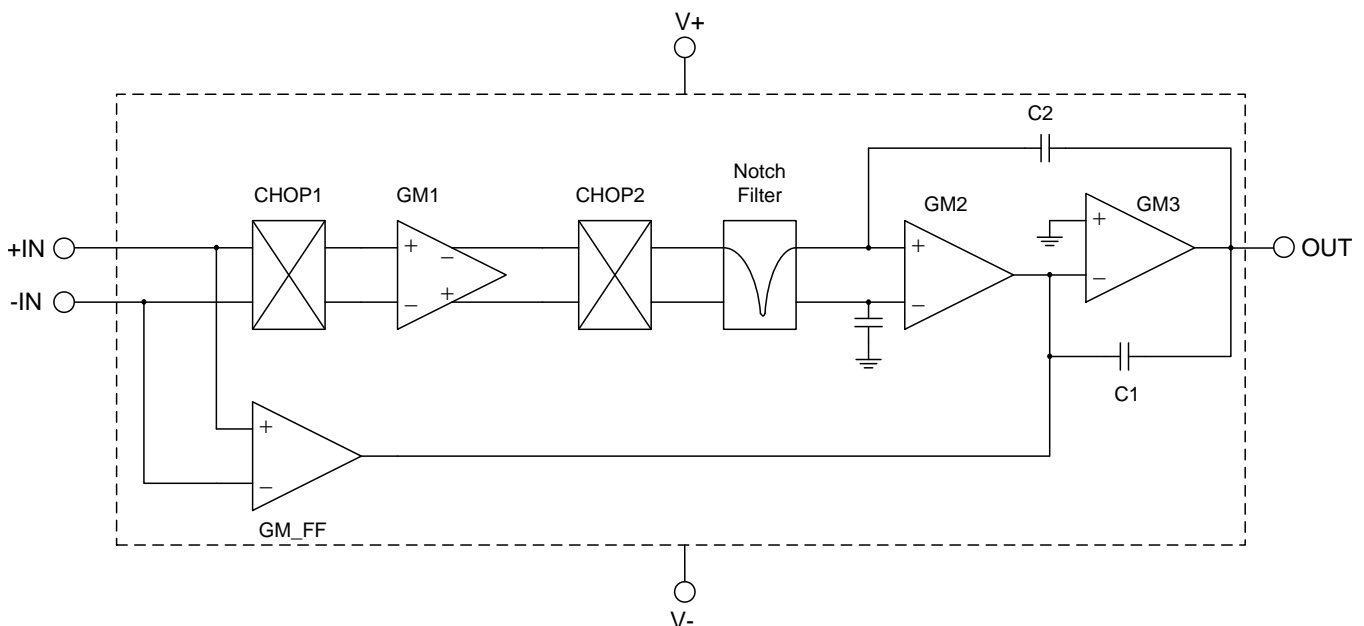

Copyright © 2016, Texas Instruments Incorporated

Figure 36. Functional Block Diagram

### 7.3 Feature Description

The OPAx187 is unity-gain stable and free from unexpected output phase reversal. This device uses a proprietary, periodic autocalibration technique to provide ultra-low input offset voltage and near zero input offset voltage drift over temp and temperature. For lowest offset voltage and precision performance, optimize circuit layout and mechanical conditions. Avoid temperature gradients that create thermoelectric (Seebeck) effects in the thermocouple junctions formed from connecting dissimilar conductors. Cancel these thermally-generated potentials by making sure they are equal on both input pins. Other layout and design considerations include:

Use low thermoelectric-coefficient conditions (avoid dissimilar metals).

Thermally isolate components from power supplies or other heat sources.

Shield operational amplifier and input circuitry from air currents, such as cooling fans.

Follow these guidelines to reduce the likelihood of junctions being at different temperatures, which may cause thermoelectric voltages of 0.1  $\mu\text{V}/^\circ\text{C}$  or higher, depending on the materials used.

#### 7.3.1 Operating Characteristics

The OPAx187 device is specified for operation from 4.5 V to 36 V ( $\pm 2.25$  V to  $\pm 18$  V). Many specifications apply from  $-40^\circ\text{C}$  to  $+125^\circ\text{C}$ . Parameters that can exhibit significant variance with regard to operating voltage or temperature are presented in the [Typical Characteristics](#) section.

#### 7.3.2 Phase-Reversal Protection

The OPAx187 device has an internal phase-reversal protection. Many op amps exhibit a phase reversal when the input is driven beyond its linear common-mode range. This condition is most often encountered in non-inverting circuits when the input is driven beyond the specified common-mode voltage range, causing the output to reverse into the opposite rail. The OPAx187 input prevents phase reversal with excessive common-mode voltage. Instead, the output limits into the appropriate rail. [Figure 37](#) shows this performance.

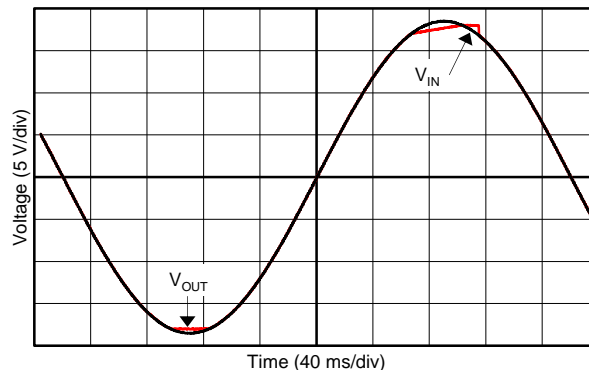

**Figure 37. No Phase Reversal**

#### 7.3.3 Input Bias Current Clock Feedthrough

Zero-drift amplifiers, such as the OPAx187, use switching on their inputs to correct for the intrinsic offset and drift of the amplifier. Charge injection from the integrated switches on the inputs can introduce very short transients in the input bias current of the amplifier. The extremely short duration of these pulses prevents them from being amplified, however they may be coupled to the output of the amplifier through the feedback network. The most effective method to prevent transients in the input bias current from producing additional noise at the amplifier output is to use a low-pass filter such as an RC network.

#### 7.3.4 Internal Offset Correction

The OPAx187 op amp uses an auto-calibration technique with a time-continuous 125-kHz op amp in the signal path. This amplifier is zero-corrected every 22  $\mu\text{s}$  using a proprietary technique. Upon power-up, the amplifier requires approximately 100  $\mu\text{s}$  to achieve the specified  $V_{OS}$  accuracy. This design has no aliasing or flicker noise.

## Feature Description (continued)

### 7.3.5 EMI Rejection

The OPAx187 device uses integrated electromagnetic interference (EMI) filtering to reduce the effects of EMI interference from sources such as wireless communications and densely-populated boards with a mix of analog signal chain and digital components. EMI immunity can be improved with circuit design techniques; the OPAx187 benefits from these design improvements. Texas Instruments has developed the ability to accurately measure and quantify the immunity of an operational amplifier over a broad frequency spectrum extending from 10 MHz to 6 GHz. [Figure 38](#) shows the results of this testing on the OPAx187. [Table 2](#) lists the EMIRR IN+ values for the OPAx187 at particular frequencies commonly encountered in real-world applications. Applications listed in [Table 2](#) may be centered on or operated near the particular frequency shown. Detailed information can also be found in *EMI Rejection Ratio of Operational Amplifiers*, available for download from [www.ti.com](http://www.ti.com).

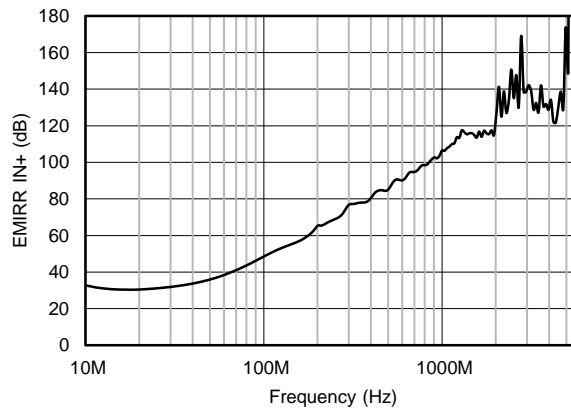

**Figure 38. EMIRR Testing**

**Table 2. OPAx187 EMIRR IN+ for Frequencies of Interest**

FREQUENCY	APPLICATION/ALLOCATION	EMIRR IN+
400 MHz	Mobile radio, mobile satellite, space operation, weather, radar, ultra-high frequency (UHF) applications	81.8 dB
900 MHz	Global system for mobile communications (GSM) applications, radio communication, navigation, GPS (to 1.6 GHz), GSM, aeronautical mobile, UHF applications	102.7 dB
1.8 GHz	GSM applications, mobile personal communications, broadband, satellite, L-band (1 GHz to 2 GHz)	115.4 dB
2.4 GHz	802.11b, 802.11g, 802.11n, Bluetooth®, mobile personal communications, industrial, scientific and medical (ISM) radio band, amateur radio and satellite, S-band (2 GHz to 4 GHz)	150.7 dB
3.6 GHz	Radiolocation, aero communication and navigation, satellite, mobile, S-band	142.0 dB
5 GHz	802.11a, 802.11n, aero communication and navigation, mobile communication, space and satellite operation, C-band (4 GHz to 8 GHz)	173.8 dB

### 7.3.6 Capacitive Load and Stability

The device dynamic characteristics are optimized for a range of common operating conditions. The combination of low closed-loop gain and high capacitive loads decreases the amplifier phase margin and can lead to gain peaking or oscillations. As a result, larger capacitive loads must be isolated from the output. The simplest way to achieve this isolation is to add a small resistor (for example,  $R_{OUT}$  equal to 50  $\Omega$ ) in series with the output. [Figure 39](#) illustrates small-signal overshoot versus capacitive load for several values of  $R_{OUT}$ . Also, for details of analysis techniques and application circuits, refer to *Feedback Plots Define Op Amp AC Performance*, available for download from [www.ti.com](http://www.ti.com).

G = 1, R<sub>L</sub> = 10 kΩ, 10-mV Output Step

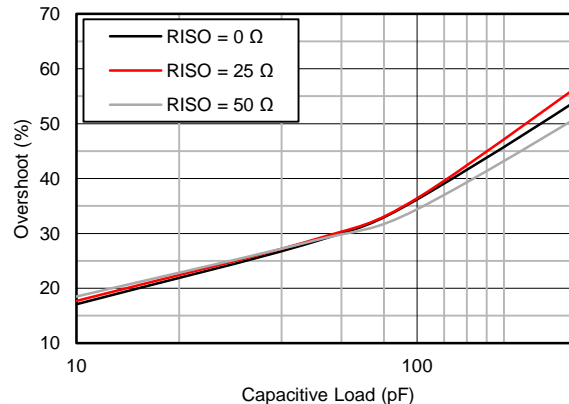

Figure 39. Small-Signal Overshoot Versus Capacitive Load

### 7.3.7 Electrical Overstress

Designers often ask questions about the capability of an operational amplifier to withstand electrical overstress. These questions tend to focus on the device inputs, but may involve the supply voltage pins or even the output pin. Each of these different pin functions have electrical stress limits determined by the voltage breakdown characteristics of the particular semiconductor fabrication process and specific circuits connected to the pin. Additionally, internal electrostatic discharge (ESD) protection is built into these circuits to protect them from accidental ESD events both before and during product assembly.

Having a good understanding of this basic ESD circuitry and its relevance to an electrical overstress event is helpful. See Figure 40 for an illustration of the ESD circuits contained in the OPAx187 (indicated by the dashed line area). The ESD protection circuitry involves several current-steering diodes connected from the input and output pins and routed back to the internal power-supply lines, where the diodes meet at an absorption device internal to the operational amplifier. This protection circuitry is intended to remain inactive during normal circuit operation.

An ESD event produces a short-duration, high-voltage pulse that is transformed into a short-duration, high-current pulse while discharging through a semiconductor device. The ESD protection circuits are designed to provide a current path around the operational amplifier core to prevent damage. The energy absorbed by the protection circuitry is then dissipated as heat.

When an ESD voltage develops across two or more amplifier device pins, current flows through one or more steering diodes. Depending on the path that the current takes, the absorption device may activate. The absorption device has a trigger, or threshold voltage, that is above the normal operating voltage of the OPAx187 but below the device breakdown voltage level. When this threshold is exceeded, the absorption device quickly activates and clamps the voltage across the supply rails to a safe level.

When the operational amplifier connects into a circuit (as shown in Figure 40), the ESD protection components are intended to remain inactive and do not become involved in the application circuit operation. However, circumstances may arise where an applied voltage exceeds the operating voltage range of a given pin. Should this condition occur, there is a risk that some internal ESD protection circuits may be biased on, and conduct current. Any such current flow occurs through steering-diode paths and rarely involves the absorption device.

Figure 40 shows a specific example where the input voltage, V<sub>IN</sub>, exceeds the positive supply voltage (+V<sub>S</sub>) by 500 mV or more. Much of what happens in the circuit depends on the supply characteristics. If +V<sub>S</sub> can sink the current, one of the upper input steering diodes conducts and directs current to +V<sub>S</sub>. Excessively high current levels can flow with increasingly higher V<sub>IN</sub>. As a result, the data sheet specifications recommend that applications limit the input current to 10 mA.

If the supply is not capable of sinking the current, V<sub>IN</sub> may begin sourcing current to the operational amplifier, and then take over as the source of positive supply voltage. The danger in this case is that the voltage can rise to levels that exceed the operational amplifier absolute maximum ratings.

Another common question involves what happens to the amplifier if an input signal is applied to the input while the power supplies  $+V_S$  or  $-V_S$  are at 0 V. Again, this question depends on the supply characteristic while at 0 V, or at a level below the input signal amplitude. If the supplies appear as high impedance, then the operational amplifier supply current may be supplied by the input source via the current-steering diodes. This state is not a normal bias condition; the amplifier most likely will not operate normally. If the supplies are low impedance, then the current through the steering diodes can become quite high. The current level depends on the ability of the input source to deliver current, and any resistance in the input path.

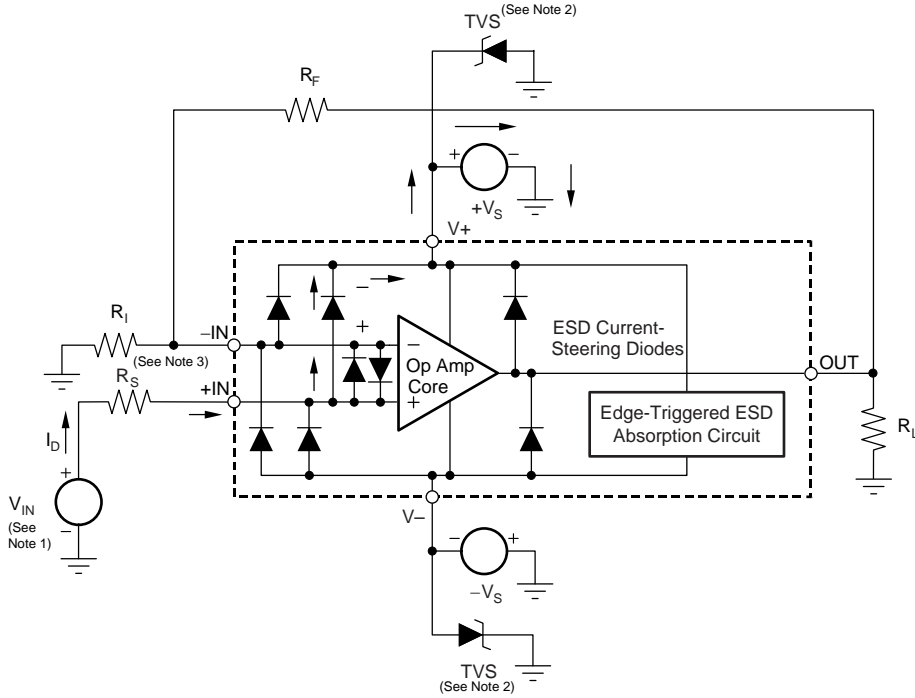
If there is any uncertainty about the ability of the supply to absorb this current, external TVS (Transient Voltage Suppressor) diodes may be added to the supply pins, as shown in . The TVS voltage must be selected such that the diode does not turn on during normal operation. However, the TVS voltage should be low enough so that the TVS diode conducts if the supply pin begins to rise above the safe operating supply voltage level.

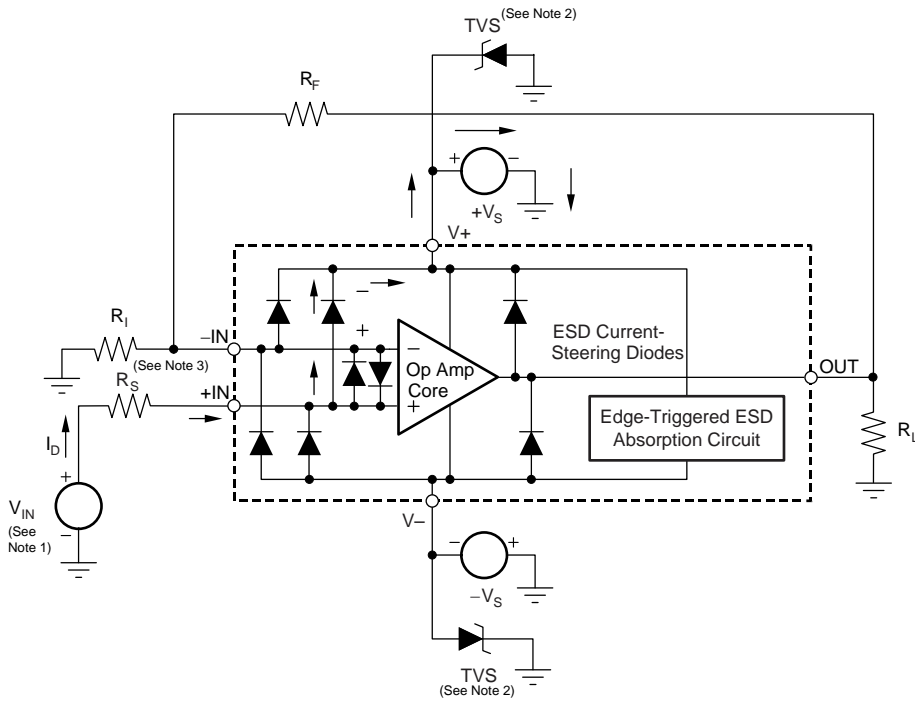



Copyright © 2016, Texas Instruments Incorporated

NOTE 1:  $V_{IN} = +V_S + 500 \text{ mV}$ .

NOTE 2: TVS:  $+V_{S(max)} > V_{TVSBR (min)} > +V_S$ .

NOTE 3: Suggested value is approximately 1 k $\Omega$ .

 40. Equivalent Internal ESD Circuitry Relative to a Typical Circuit Application

The OPAx187 input terminals are protected from excessive differential voltage with back-to-back diodes, as shown in . In most circuit applications, the input protection circuitry has no consequence. However, in low-gain or  $G = 1$  circuits, fast-ramping input signals can forward-bias these diodes because the output of the amplifier cannot respond rapidly enough to the input ramp. If the input signal is fast enough to create this forward-bias condition, the input signal current must be limited to 10 mA or less. If the input signal current is not inherently limited, an input series resistor can be used to limit the signal input current. This input series resistor degrades the low-noise performance of the OPAx187.  shows an example configuration that implements a current-limiting feedback resistor.

### 7.4 Device Functional Modes

The OPAx187 has a single functional mode and is operational when the power-supply voltage is greater than 4.5 V ( $\pm 2.25 \text{ V}$ ). The maximum power supply voltage for the OPAx187 is 36 V ( $\pm 18 \text{ V}$ ).

## 8 Application and Implementation

### 注

Information in the following applications sections is not part of the TI component specification, and TI does not warrant its accuracy or completeness. TI's customers are responsible for determining suitability of components for their purposes. Customers should validate and test their design implementation to confirm system functionality.

### 8.1 Application Information

The OPAx187 operational amplifier combines precision offset and drift with excellent overall performance, making it ideal for many precision applications. The precision offset drift of only  $0.001 \mu\text{V}/^\circ\text{C}$  provides stability over the entire temperature range. In addition, the device pairs excellent CMRR, PSRR, and  $A_{OL}$  dc performance with outstanding low-noise operation. As with all amplifiers, applications with noisy or high-impedance power supplies require decoupling capacitors close to the device pins. In most cases,  $0.1\text{-}\mu\text{F}$  capacitors are adequate.

The following application examples highlight only a few of the circuits where the OPAx187 can be used.

### 8.2 Typical Applications

#### 8.2.1 High-Side Voltage-to-Current (V-I) Converter

The circuit shown in [Figure 41](#) is a high-side voltage-to-current (V-I) converter. The converter translates an input voltage of  $0\text{ V}$  to  $2\text{ V}$  into an output current of  $0\text{ mA}$  to  $100\text{ mA}$ . [Figure 42](#) shows the measured transfer function for this circuit. The low offset voltage and offset drift of the OPA2187 facilitate excellent dc accuracy for the circuit.

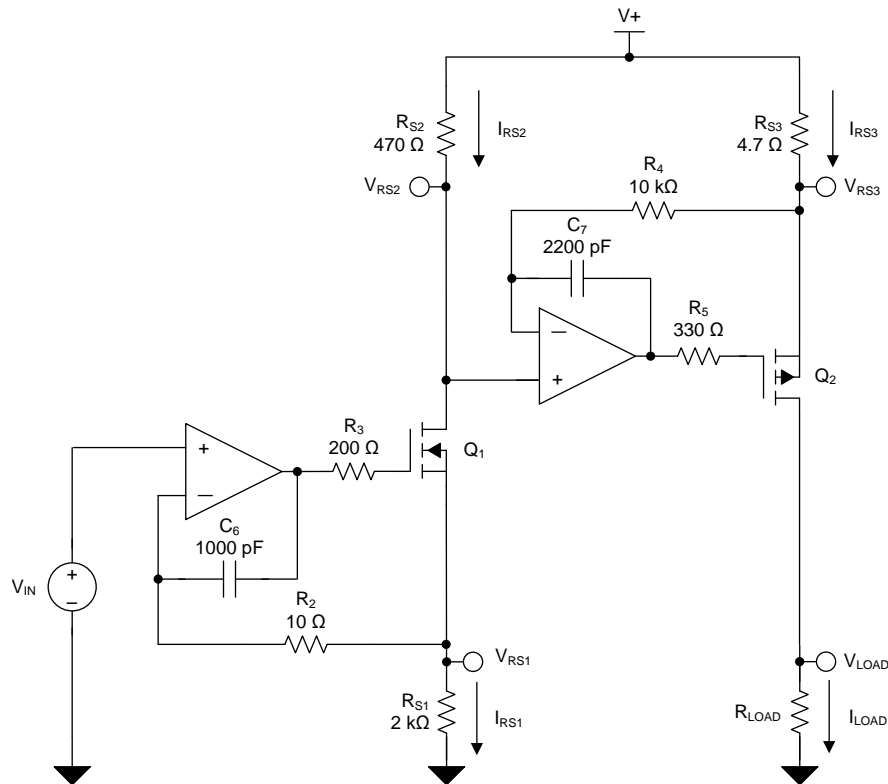

Copyright © 2016, Texas Instruments Incorporated

**Figure 41. High-Side Voltage-to-Current (V-I) Converter**

#### 8.2.1.1 Design Requirements

The design requirements are:

## Typical Applications (continued)

- Supply voltage: 5 V DC
- Input: 0 V to 2 V DC
- Output: 0 mA to 100 mA DC

### 8.2.1.2 Detailed Design Procedure

The V-I transfer function of the circuit is based on the relationship between the input voltage,  $V_{IN}$ , and the three current sensing resistors,  $R_{S1}$ ,  $R_{S2}$ , and  $R_{S3}$ . The relationship between  $V_{IN}$  and  $R_{S1}$  determines the current that flows through the first stage of the design. The current gain from the first stage to the second stage is based on the relationship between  $R_{S2}$  and  $R_{S3}$ .

This application benefits from an operational amplifier with low offset voltage, low temperature drift, and rail-to-rail output. The OPAx187 CMOS operational amplifier is a high-precision, ultra-low offset, ultra-low drift amplifier, optimized for wide-voltage, single-supply operation, with an output swing to within 5 mV of the positive rail. The OPAx187 family uses chopping techniques to provide low initial offset voltage and near-zero drift over time and temperature. Low offset voltage and low drift reduce the offset error in the system, making this device appropriate for precise dc control. The rail-to-rail output stage of the OPAx187 makes sure that the output swing of the operational amplifier is able to fully control the gate of the MOSFET devices within the supply rails.

A detailed error analysis, design procedure, and additional measured results are given in reference design TIPD102, a step-by-step process to design a [High-Side Voltage-to-Current \(V-I\) Converter](#).



For step-by-step design procedure, circuit schematics, bill of materials, PCB files, simulation results, and test results, refer to [TI Precision Design TIPD102, High-Side Voltage-to-Current \(V-I\) Converter \(SLAU502\)](#).

### 8.2.1.3 Application Curve

Figure 42 shows the measured transfer function for the high-side voltage-to-current converter shown in Figure 41.

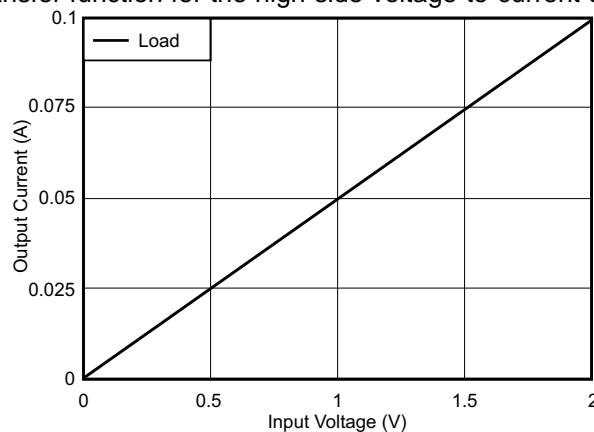

Figure 42. Measured Transfer Function for High-Side V-I Converter

## 8.2.2 Discrete INA + Attenuation for ADC With 3.3-V Supply

### 注

The TINA-TI files shown in the following sections require that either the TINA software (from DesignSoft™) or TINA-TI software be installed. Download the free TINA-TI software from the [TINA-TI folder](#).

Figure 43 shows an example of how the OPAx187 is used as a high-voltage, high-impedance front-end for a precision, discrete instrumentation amplifier with attenuation. The INA159 provides the attenuation that allows this circuit to easily interface with 3.3-V or 5-V analog-to-digital converters (ADCs). Click the following link to download the TINA-TI file: [Discrete INA](#).

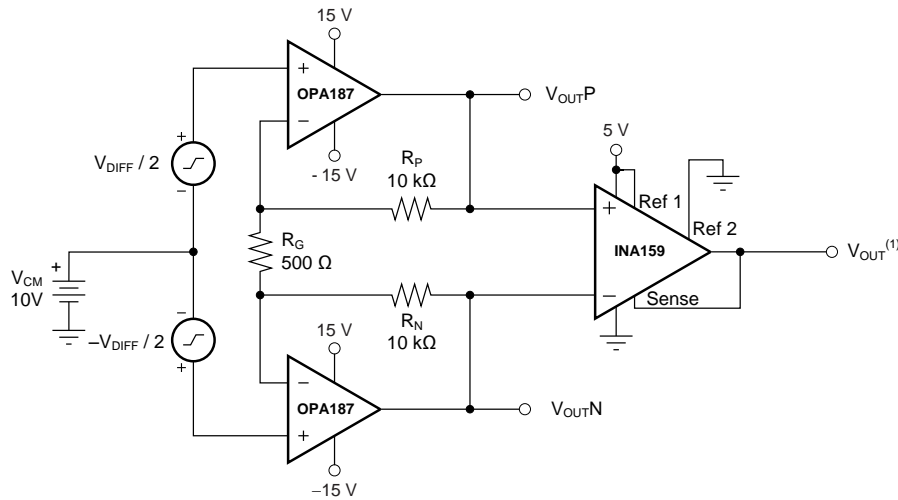

Copyright © 2016, Texas Instruments Incorporated

$$(1) V_{OUT} = V_{DIFF} \times (41 / 5) + (Ref 1) / 2.$$

Figure 43. Discrete INA + Attenuation for ADC With 3.3-V Supply

### 8.2.3 Bridge Amplifier

Figure 44 shows the basic configuration for a bridge amplifier. Click the following link to download the TINA-TI file: [Bridge Amplifier Circuit](#).

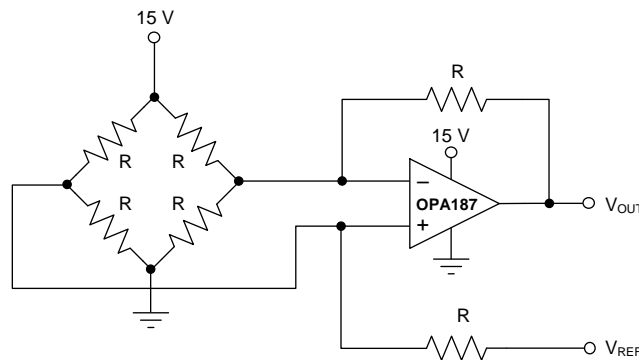

Copyright © 2016, Texas Instruments Incorporated

Figure 44. Bridge Amplifier

### 8.2.4 Low-Side Current Monitor

Figure 45 shows the OPAx187 configured in a low-side current-sensing application. The load current ( $I_{LOAD}$ ) creates a voltage drop across the shunt resistor ( $R_{SHUNT}$ ). This voltage is amplified by the OPAx187, with a gain of 201. The load current is set from 0 A to 500 mA, which corresponds to an output voltage range from 0 V to 10 V. The output range can be adjusted by changing the shunt resistor or gain of the configuration. Click the following link to download the TINA-TI file: [Current-Sensing Circuit](#).

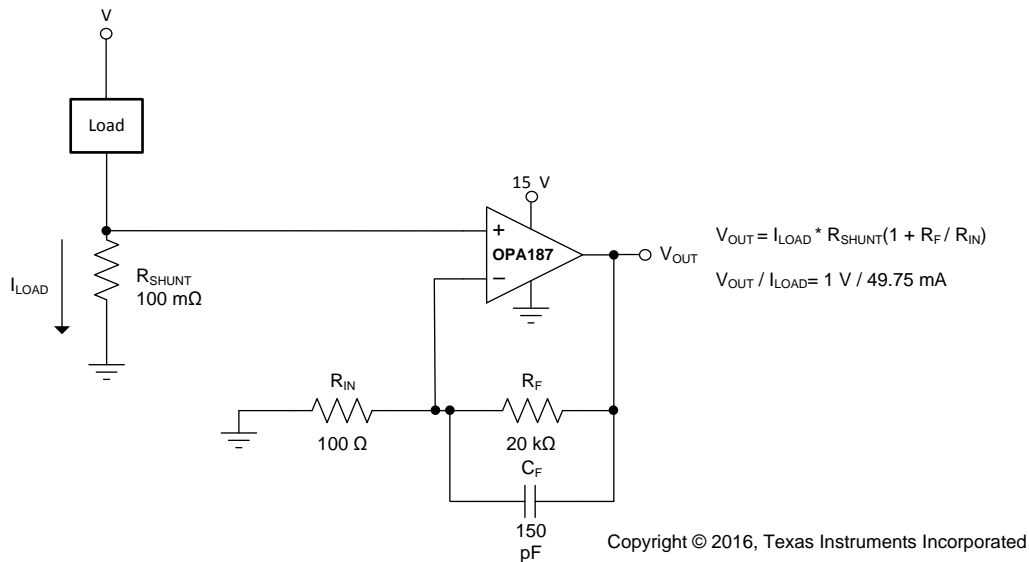
**☒ 45. Low-Side Current Monitor**

### 8.2.5 Programmable Power Supply

☒ 46 shows the OPAx187 configured as a precision programmable power supply using the 16-bit, voltage output DAC8581 and the OPA548 high-current amplifier. This application amplifies the digital-to-analog converter (DAC) voltage by a value of five, and handles a large variety of capacitive and current loads. The OPAx187 in the front-end provides precision and low drift across a wide range of inputs and conditions. Click the following link to download the TINA-TI file: [Programmable Power-Supply Circuit](#).

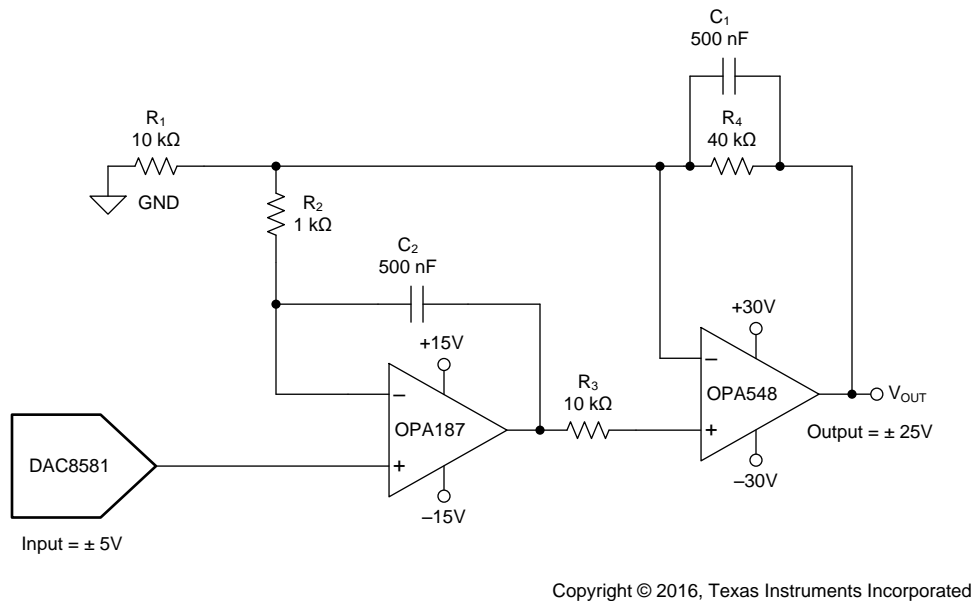
**☒ 46. Programmable Power Supply**

### 8.2.6 RTD Amplifier With Linearization

See [Analog Linearization Of Resistance Temperature Detectors](#), for an in-depth analysis of [Figure 47](#). Click the following link to download the TINA-TI file: [RTD Amplifier With Linearization](#).

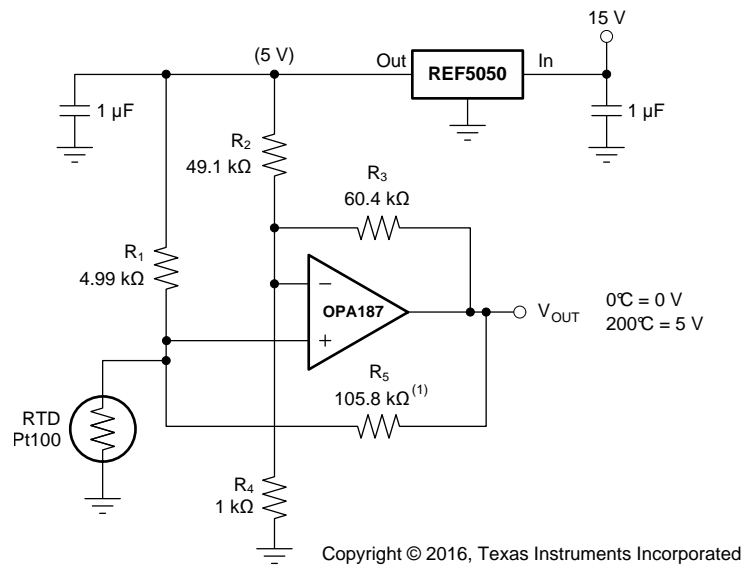

(1)  $R_5$  provides positive-varying excitation to linearize output.

**Figure 47. RTD Amplifier With Linearization**

## 9 Power Supply Recommendations

The OPAx187 is specified for operation from 4.5 V to 36 V ( $\pm 2.25$  V to  $\pm 18$  V); many specifications apply from  $-40^\circ\text{C}$  to  $+125^\circ\text{C}$ . The [Typical Characteristics](#) presents parameters that can exhibit significant variance with regard to operating voltage or temperature.

### 注意

Supply voltages larger than 40 V can permanently damage the device (see the [Absolute Maximum Ratings](#)).

Place 0.1- $\mu\text{F}$  bypass capacitors close to the power-supply pins to reduce errors coupling in from noisy or high-impedance power supplies. For more detailed information on bypass capacitor placement, see the [Layout](#) section.

## 10 Layout

### 10.1 Layout Guidelines

For best operational performance of the device, use good printed circuit board (PCB) layout practices, including:

- Low-ESR, 0.1- $\mu$ F ceramic bypass capacitors must be connected between each supply pin and ground; place the capacitors as close to the device as possible. A single bypass capacitor from V+ to ground is applicable to single-supply applications.
- To reduce parasitic coupling, run the input traces as far away from the supply lines as possible.
- A ground plane helps distribute heat and reduces EMI noise pickup.
- Place the external components as close to the device as possible. This configuration prevents parasitic errors (such as the Seebeck effect) from occurring.
- Consider a driven, low-impedance guard ring around the critical traces. A guard ring can significantly reduce leakage currents from nearby traces that are at different potentials.

### 10.2 Layout Example

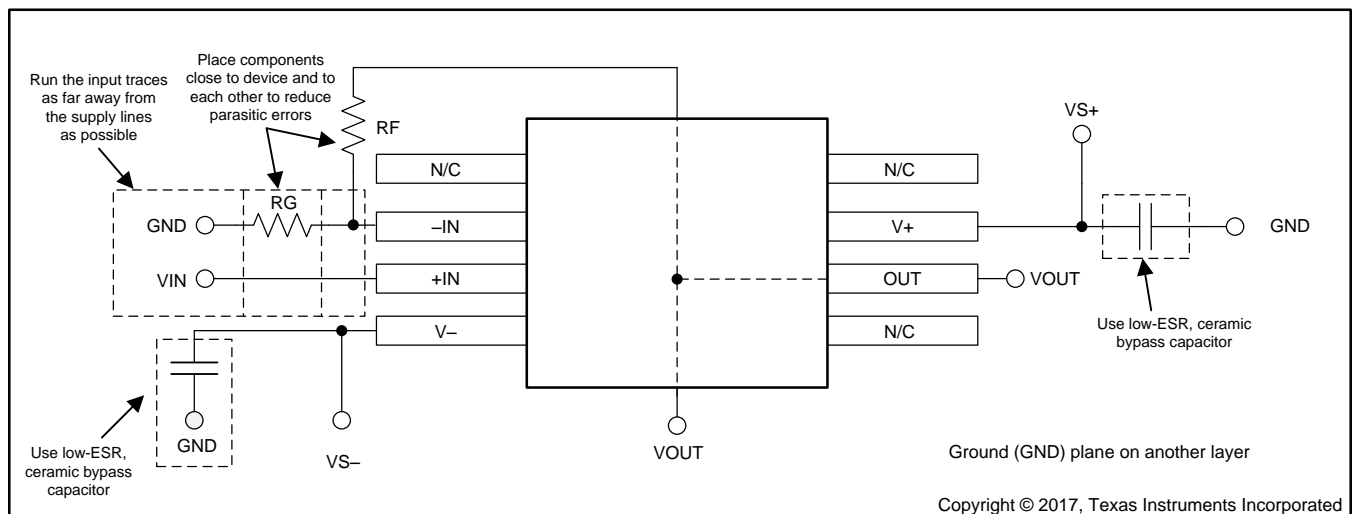
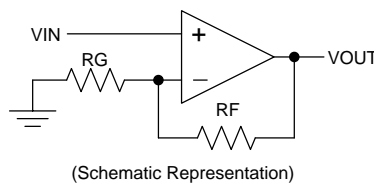

⊠ 48. Layout Example

## 11 デバイスおよびドキュメントのサポート

### 11.1 デバイス・サポート

#### 11.1.1 開発サポート

##### 11.1.1.1 TINA-TI™ (無料のダウンロード・ソフトウェア)

TINA™は、SPICEエンジンをベースにした単純かつ強力な、使いやすい回路シミュレーション・プログラムです。また、TINA-TI™はTINAソフトウェアの無料バージョンで、完全な機能を持ち、パッシブとアクティブ両方の広範なモデルに加えて、マクロ・モデルのライブラリがプリロードされています。TINA-TIには従来型のDC、過渡、および周波数ドメインのSPICEによる分析と、追加の設計機能が搭載されています。

TINA-TIはAnalog eLab Design Centerから無料でダウンロードでき、ユーザーが結果をさまざまな方法でフォーマットできる、広範な後処理機能を備えています。仮想計測器により、入力波形を選択し、回路ノード、電圧、および波形をプローブして、動的なクイック・スタート・ツールを作成できます。

#### 注

これらのファイルを使用するには、TINA ソフトウェア ( DesignSoft™製) またはTINA-TIソフトウェアがインストールされている必要があります。TINA-TIフォルダから、無料のTINA-TIソフトウェアをダウンロードしてください。

##### 11.1.1.2 TI Precision Designs

TI Precision Designsは、TIの高精度アナログ・アプリケーションの専門家により作成されたアナログ・ソリューションで、多くの有用な回路に関して、動作理論、コンポーネント選択、シミュレーション、完全なPCB回路図とレイアウト、部品表、性能測定結果を提供します。TI Precision Designs は、<http://www.ti.com/ww/en/analog/precision-designs/> からオンラインで入手できます。

##### 11.1.1.3 WEBENCH® Filter Designer

WEBENCH® Filter Designerは単純で強力な、使いやすいアクティブ・フィルタ設計プログラムです。WEBENCH Filter Designerを使用すると、TIのベンダ・パートナーからのTI製オペアンプやパッシブ・コンポーネントを使用して、最適なフィルタ設計を作成できます。

WEBENCH® Filter Designerは、WEBENCH Design CenterからWebベースのツールとして利用でき、完全な複数段アクティブ・フィルタ・ソリューションをわずか数分で設計、最適化、シミュレーションできます。

## 11.2 ドキュメントのサポート

### 11.2.1 関連資料

関連資料については、以下を参照してください。

- テキサス・インスツルメンツ、『オペアンプのゲイン安定性、第3部: ACゲイン誤差の解析』
- テキサス・インスツルメンツ、『オペアンプのゲイン安定性、第2部: DCゲイン誤差の解析』
- テキサス・インスツルメンツ、『完全差動アクティブ・フィルタにおける無限ゲイン、MFBフィルタ・トポロジの使用』
- テキサス・インスツルメンツ、『オペアンプの性能分析』
- テキサス・インスツルメンツ、『オペアンプの単一電源動作』
- テキサス・インスツルメンツ、『アンプのチューニング』
- テキサス・インスツルメンツ、『鉛フリー仕上げ部品の保管寿命評価』

### 11.3 関連リンク

表 3 に、クイック・アクセス・リンクの一覧を示します。カテゴリには、技術資料、サポートおよびコミュニティ・リソース、ツールとソフトウェア、およびサンプル注文またはご購入へのクイック・アクセスが含まれます。

表 3. 関連リンク

製品	プロダクト・フォルダ	サンプルと購入	技術資料	ツールとソフトウェア	サポートとコミュニティ
OPA187	<a href="#">ここをクリック</a>	<a href="#">ここをクリック</a>	<a href="#">ここをクリック</a>	<a href="#">ここをクリック</a>	<a href="#">ここをクリック</a>
OPA2187	<a href="#">ここをクリック</a>	<a href="#">ここをクリック</a>	<a href="#">ここをクリック</a>	<a href="#">ここをクリック</a>	<a href="#">ここをクリック</a>
OPA4187	<a href="#">ここをクリック</a>	<a href="#">ここをクリック</a>	<a href="#">ここをクリック</a>	<a href="#">ここをクリック</a>	<a href="#">ここをクリック</a>

### 11.4 ドキュメントの更新通知を受け取る方法

ドキュメントの更新についての通知を受け取るには、[ti.com](http://ti.com)のデバイス製品フォルダを開いてください。右上の「アラートを受け取る」をクリックして登録すると、変更されたすべての製品情報に関するダイジェストを毎週受け取れます。変更の詳細については、修正されたドキュメントに含まれている改訂履歴をご覧ください。

### 11.5 コミュニティ・リソース

The following links connect to TI community resources. Linked contents are provided "AS IS" by the respective contributors. They do not constitute TI specifications and do not necessarily reflect TI's views; see TI's [Terms of Use](#).

**TI E2E™オンライン・コミュニティ** *TIのE2E ( Engineer-to-Engineer )* コミュニティ。エンジニア間の共同作業を促進するために開設されたものです。e2e.ti.comでは、他のエンジニアに質問し、知識を共有し、アイデアを検討して、問題解決に役立てることができます。

**設計サポート** *TIの設計サポート* 役に立つE2Eフォーラムや、設計サポート・ ツールをすばやく見つけることができます。技術サポート用の連絡先情報も参照できます。

### 11.6 商標

TINA-TI, E2E are trademarks of Texas Instruments.  
 WEBENCH is a registered trademark of Texas Instruments.  
 Bluetooth is a registered trademark of Bluetooth SIG, Inc.  
 DesignSoft, TINA are trademarks of DesignSoft, Inc.  
 All other trademarks are the property of their respective owners.

### 11.7 静電気放電に関する注意事項



すべての集積回路は、適切なESD保護方法を用いて、取扱いと保存を行うようにして下さい。

静電気放電はわずかな性能の低下から完全なデバイスの故障に至るまで、様々な損傷を与えます。高精度の集積回路は、損傷に対して敏感であり、極めてわずかなパラメータの変化により、デバイスに規定された仕様に適合しなくなる場合があります。

### 11.8 Glossary

**SLYZ022** — *TI Glossary*.

This glossary lists and explains terms, acronyms, and definitions.

## 12 メカニカル、パッケージ、および注文情報

以降のページには、メカニカル、パッケージ、および注文に関する情報が記載されています。この情報は、そのデバイスについて利用可能な最新のデータです。このデータは予告なく変更されることがあり、ドキュメントが改訂される場合もあります。本データシートのブラウザ版を使用されている場合は、画面左側の説明をご覧ください。

**PACKAGING INFORMATION**

Orderable part number	Status (1)	Material type (2)	Package   Pins	Package qty   Carrier	RoHS (3)	Lead finish/ Ball material (4)	MSL rating/ Peak reflow (5)	Op temp (°C)	Part marking (6)
<a href="#">OPA187ID</a>	Active	Production	SOIC (D)   8	75   TUBE	Yes	NIPDAU	Level-2-260C-1 YEAR	-40 to 125	OPA187
OPA187ID.B	Active	Production	SOIC (D)   8	75   TUBE	Yes	NIPDAU	Level-2-260C-1 YEAR	-40 to 125	OPA187
<a href="#">OPA187IDBVR</a>	Active	Production	SOT-23 (DBV)   5	3000   LARGE T&R	Yes	NIPDAU	Level-2-260C-1 YEAR	-40 to 125	1CUV
OPA187IDBVR.B	Active	Production	SOT-23 (DBV)   5	3000   LARGE T&R	Yes	NIPDAU	Level-2-260C-1 YEAR	-40 to 125	1CUV
<a href="#">OPA187IDBVT</a>	Active	Production	SOT-23 (DBV)   5	250   SMALL T&R	Yes	NIPDAU	Level-2-260C-1 YEAR	-40 to 125	1CUV
OPA187IDBVT.B	Active	Production	SOT-23 (DBV)   5	250   SMALL T&R	Yes	NIPDAU	Level-2-260C-1 YEAR	-40 to 125	1CUV
OPA187IDBVTG4	Active	Production	SOT-23 (DBV)   5	250   SMALL T&R	Yes	NIPDAU	Level-2-260C-1 YEAR	-40 to 125	1CUV
OPA187IDBVTG4.B	Active	Production	SOT-23 (DBV)   5	250   SMALL T&R	Yes	NIPDAU	Level-2-260C-1 YEAR	-40 to 125	1CUV
OPA187IDG4	Active	Production	SOIC (D)   8	75   TUBE	Yes	NIPDAU	Level-2-260C-1 YEAR	-40 to 125	OPA187
OPA187IDG4.B	Active	Production	SOIC (D)   8	75   TUBE	Yes	NIPDAU	Level-2-260C-1 YEAR	-40 to 125	OPA187
<a href="#">OPA187IDGKR</a>	Active	Production	VSSOP (DGK)   8	2500   LARGE T&R	Yes	NIPDAUAG   SN	Level-2-260C-1 YEAR	-40 to 125	1D96
OPA187IDGKR.B	Active	Production	VSSOP (DGK)   8	2500   LARGE T&R	Yes	SN	Level-2-260C-1 YEAR	-40 to 125	1D96
<a href="#">OPA187IDGKT</a>	Active	Production	VSSOP (DGK)   8	250   SMALL T&R	Yes	NIPDAUAG   SN	Level-2-260C-1 YEAR	-40 to 125	1D96
OPA187IDGKT.B	Active	Production	VSSOP (DGK)   8	250   SMALL T&R	Yes	SN	Level-2-260C-1 YEAR	-40 to 125	1D96
<a href="#">OPA187IDR</a>	Active	Production	SOIC (D)   8	2500   LARGE T&R	Yes	NIPDAU	Level-2-260C-1 YEAR	-40 to 125	OPA187
OPA187IDR.B	Active	Production	SOIC (D)   8	2500   LARGE T&R	Yes	NIPDAU	Level-2-260C-1 YEAR	-40 to 125	OPA187
<a href="#">OPA2187ID</a>	Active	Production	SOIC (D)   8	75   TUBE	Yes	NIPDAU	Level-2-260C-1 YEAR	-40 to 125	OP2187
OPA2187ID.B	Active	Production	SOIC (D)   8	75   TUBE	Yes	NIPDAU	Level-2-260C-1 YEAR	-40 to 125	OP2187
<a href="#">OPA2187IDGKR</a>	Active	Production	VSSOP (DGK)   8	2500   LARGE T&R	Yes	Call TI   Nipdau	Level-2-260C-1 YEAR	-40 to 125	16TV
OPA2187IDGKR.B	Active	Production	VSSOP (DGK)   8	2500   LARGE T&R	Yes	Call TI	Level-2-260C-1 YEAR	-40 to 125	16TV
OPA2187IDGKRG4	Active	Production	VSSOP (DGK)   8	2500   LARGE T&R	Yes	NIPDAU	Level-2-260C-1 YEAR	-40 to 125	16TV
OPA2187IDGKRG4.B	Active	Production	VSSOP (DGK)   8	2500   LARGE T&R	Yes	NIPDAU	Level-2-260C-1 YEAR	-40 to 125	16TV
<a href="#">OPA2187IDGKT</a>	Active	Production	VSSOP (DGK)   8	250   SMALL T&R	Yes	Call TI   Nipdau	Level-2-260C-1 YEAR	-40 to 125	16TV
OPA2187IDGKT.B	Active	Production	VSSOP (DGK)   8	250   SMALL T&R	Yes	Call TI	Level-2-260C-1 YEAR	-40 to 125	16TV
<a href="#">OPA2187IDR</a>	Active	Production	SOIC (D)   8	2500   LARGE T&R	Yes	NIPDAU	Level-2-260C-1 YEAR	-40 to 125	OP2187
OPA2187IDR.B	Active	Production	SOIC (D)   8	2500   LARGE T&R	Yes	NIPDAU	Level-2-260C-1 YEAR	-40 to 125	OP2187
OPA2187IDRG4	Active	Production	SOIC (D)   8	2500   LARGE T&R	Yes	NIPDAU	Level-2-260C-1 YEAR	-40 to 125	OP2187
OPA2187IDRG4.B	Active	Production	SOIC (D)   8	2500   LARGE T&R	Yes	NIPDAU	Level-2-260C-1 YEAR	-40 to 125	OP2187
<a href="#">OPA4187ID</a>	Active	Production	SOIC (D)   14	50   TUBE	Yes	NIPDAU	Level-2-260C-1 YEAR	-40 to 125	OPA4187

Orderable part number	Status (1)	Material type (2)	Package   Pins	Package qty   Carrier	RoHS (3)	Lead finish/ Ball material (4)	MSL rating/ Peak reflow (5)	Op temp (°C)	Part marking (6)
OPA4187ID.B	Active	Production	SOIC (D)   14	50   TUBE	Yes	NIPDAU	Level-2-260C-1 YEAR	-40 to 125	OPA4187
OPA4187IDG4	Active	Production	SOIC (D)   14	50   TUBE	Yes	NIPDAU	Level-2-260C-1 YEAR	-40 to 125	OPA4187
OPA4187IDG4.B	Active	Production	SOIC (D)   14	50   TUBE	Yes	NIPDAU	Level-2-260C-1 YEAR	-40 to 125	OPA4187
<a href="#">OPA4187IDR</a>	Active	Production	SOIC (D)   14	2500   LARGE T&R	Yes	NIPDAU	Level-2-260C-1 YEAR	-40 to 125	OPA4187
OPA4187IDR.B	Active	Production	SOIC (D)   14	2500   LARGE T&R	Yes	NIPDAU	Level-2-260C-1 YEAR	-40 to 125	OPA4187
<a href="#">OPA4187IPW</a>	Active	Production	TSSOP (PW)   14	90   TUBE	Yes	NIPDAU	Level-2-260C-1 YEAR	-40 to 125	OPA4187
OPA4187IPW.B	Active	Production	TSSOP (PW)   14	90   TUBE	Yes	NIPDAU	Level-2-260C-1 YEAR	-40 to 125	OPA4187
<a href="#">OPA4187IPWR</a>	Active	Production	TSSOP (PW)   14	2000   LARGE T&R	Yes	NIPDAU	Level-2-260C-1 YEAR	-40 to 125	OPA4187
OPA4187IPWR.B	Active	Production	TSSOP (PW)   14	2000   LARGE T&R	Yes	NIPDAU	Level-2-260C-1 YEAR	-40 to 125	OPA4187
OPA4187IPWRG4	Active	Production	TSSOP (PW)   14	2000   LARGE T&R	Yes	NIPDAU	Level-2-260C-1 YEAR	-40 to 125	OPA4187
OPA4187IPWRG4.B	Active	Production	TSSOP (PW)   14	2000   LARGE T&R	Yes	NIPDAU	Level-2-260C-1 YEAR	-40 to 125	OPA4187
<a href="#">OPA4187IRUMR</a>	Active	Production	WQFN (RUM)   16	3000   LARGE T&R	Yes	SN	Level-1-260C-UNLIM	-40 to 125	OPA 4187
OPA4187IRUMR.B	Active	Production	WQFN (RUM)   16	3000   LARGE T&R	Yes	SN	Level-1-260C-UNLIM	-40 to 125	OPA 4187
<a href="#">OPA4187IRUMT</a>	Active	Production	WQFN (RUM)   16	250   SMALL T&R	Yes	SN	Level-1-260C-UNLIM	-40 to 125	OPA 4187
OPA4187IRUMT.B	Active	Production	WQFN (RUM)   16	250   SMALL T&R	Yes	SN	Level-1-260C-UNLIM	-40 to 125	OPA 4187

(1) **Status:** For more details on status, see our [product life cycle](#).

(2) **Material type:** When designated, preproduction parts are prototypes/experimental devices, and are not yet approved or released for full production. Testing and final process, including without limitation quality assurance, reliability performance testing, and/or process qualification, may not yet be complete, and this item is subject to further changes or possible discontinuation. If available for ordering, purchases will be subject to an additional waiver at checkout, and are intended for early internal evaluation purposes only. These items are sold without warranties of any kind.

(3) **RoHS values:** Yes, No, RoHS Exempt. See the [TI RoHS Statement](#) for additional information and value definition.

(4) **Lead finish/Ball material:** Parts may have multiple material finish options. Finish options are separated by a vertical ruled line. Lead finish/Ball material values may wrap to two lines if the finish value exceeds the maximum column width.

(5) **MSL rating/Peak reflow:** The moisture sensitivity level ratings and peak solder (reflow) temperatures. In the event that a part has multiple moisture sensitivity ratings, only the lowest level per JEDEC standards is shown. Refer to the shipping label for the actual reflow temperature that will be used to mount the part to the printed circuit board.

**(6) Part marking:** There may be an additional marking, which relates to the logo, the lot trace code information, or the environmental category of the part.

Multiple part markings will be inside parentheses. Only one part marking contained in parentheses and separated by a "~" will appear on a part. If a line is indented then it is a continuation of the previous line and the two combined represent the entire part marking for that device.

**Important Information and Disclaimer:** The information provided on this page represents TI's knowledge and belief as of the date that it is provided. TI bases its knowledge and belief on information provided by third parties, and makes no representation or warranty as to the accuracy of such information. Efforts are underway to better integrate information from third parties. TI has taken and continues to take reasonable steps to provide representative and accurate information but may not have conducted destructive testing or chemical analysis on incoming materials and chemicals. TI and TI suppliers consider certain information to be proprietary, and thus CAS numbers and other limited information may not be available for release.

In no event shall TI's liability arising out of such information exceed the total purchase price of the TI part(s) at issue in this document sold by TI to Customer on an annual basis.

## TAPE AND REEL INFORMATION

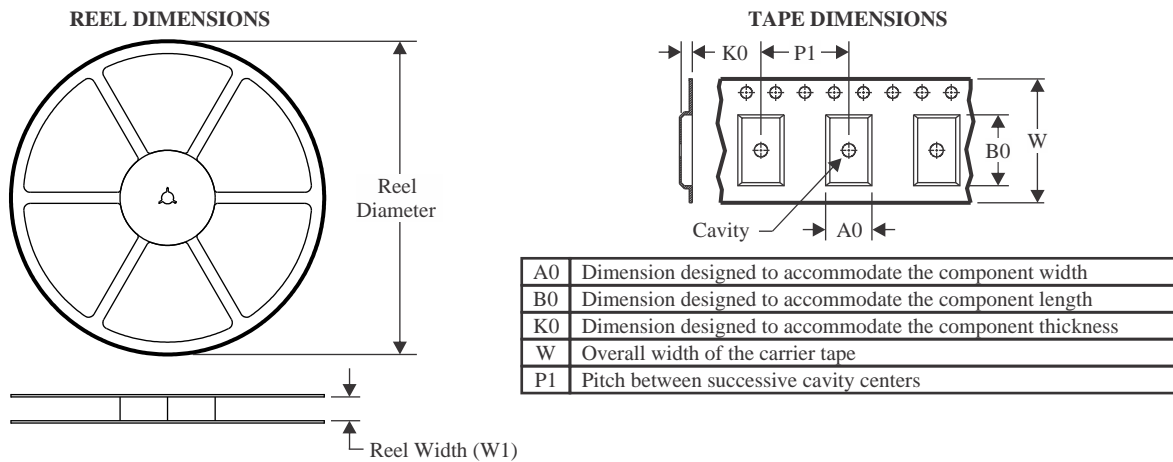

### QUADRANT ASSIGNMENTS FOR PIN 1 ORIENTATION IN TAPE

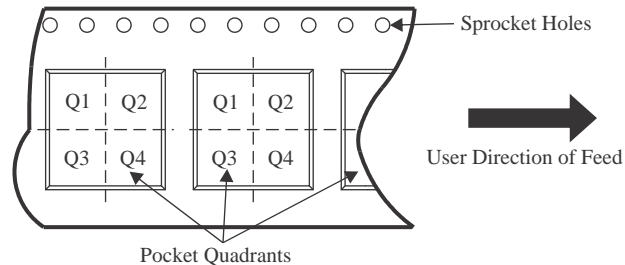

\*All dimensions are nominal

Device	Package Type	Package Drawing	Pins	SPQ	Reel Diameter (mm)	Reel Width W1 (mm)	A0 (mm)	B0 (mm)	K0 (mm)	P1 (mm)	W (mm)	Pin1 Quadrant
OPA187IDBVR	SOT-23	DBV	5	3000	180.0	8.4	3.23	3.17	1.37	4.0	8.0	Q3
OPA187IDBVT	SOT-23	DBV	5	250	180.0	8.4	3.23	3.17	1.37	4.0	8.0	Q3
OPA187IDBVTG4	SOT-23	DBV	5	250	180.0	8.4	3.23	3.17	1.37	4.0	8.0	Q3
OPA187IDGKR	VSSOP	DGK	8	2500	330.0	12.4	5.25	3.35	1.25	8.0	12.0	Q1
OPA187IDGKT	VSSOP	DGK	8	250	330.0	12.4	5.25	3.35	1.25	8.0	12.0	Q1
OPA187IDR	SOIC	D	8	2500	330.0	12.4	6.4	5.2	2.1	8.0	12.0	Q1
OPA2187IDGKR	VSSOP	DGK	8	2500	330.0	12.4	5.3	3.4	1.4	8.0	12.0	Q1
OPA2187IDGKRG4	VSSOP	DGK	8	2500	330.0	12.4	5.3	3.4	1.4	8.0	12.0	Q1
OPA2187IDGKT	VSSOP	DGK	8	250	180.0	12.4	5.3	3.4	1.4	8.0	12.0	Q1
OPA2187IDR	SOIC	D	8	2500	330.0	12.4	6.4	5.2	2.1	8.0	12.0	Q1
OPA2187IDRG4	SOIC	D	8	2500	330.0	12.4	6.4	5.2	2.1	8.0	12.0	Q1
OPA4187IDR	SOIC	D	14	2500	330.0	16.4	6.5	9.0	2.1	8.0	16.0	Q1
OPA4187IPWR	TSSOP	PW	14	2000	330.0	12.4	6.9	5.6	1.6	8.0	12.0	Q1
OPA4187IPWRG4	TSSOP	PW	14	2000	330.0	12.4	6.9	5.6	1.6	8.0	12.0	Q1
OPA4187IRUMR	WQFN	RUM	16	3000	330.0	12.4	4.25	4.25	1.15	8.0	12.0	Q2
OPA4187IRUMT	WQFN	RUM	16	250	180.0	12.4	4.25	4.25	1.15	8.0	12.0	Q2

**TAPE AND REEL BOX DIMENSIONS**

\*All dimensions are nominal

Device	Package Type	Package Drawing	Pins	SPQ	Length (mm)	Width (mm)	Height (mm)
OPA187IDBVR	SOT-23	DBV	5	3000	213.0	191.0	35.0
OPA187IDBVT	SOT-23	DBV	5	250	213.0	191.0	35.0
OPA187IDBVTG4	SOT-23	DBV	5	250	213.0	191.0	35.0
OPA187IDGKR	VSSOP	DGK	8	2500	366.0	364.0	50.0
OPA187IDGKT	VSSOP	DGK	8	250	366.0	364.0	50.0
OPA187IDR	SOIC	D	8	2500	353.0	353.0	32.0
OPA2187IDGKR	VSSOP	DGK	8	2500	353.0	353.0	32.0
OPA2187IDGKRG4	VSSOP	DGK	8	2500	353.0	353.0	32.0
OPA2187IDGKT	VSSOP	DGK	8	250	213.0	191.0	35.0
OPA2187IDR	SOIC	D	8	2500	353.0	353.0	32.0
OPA2187IDRG4	SOIC	D	8	2500	353.0	353.0	32.0
OPA4187IDR	SOIC	D	14	2500	353.0	353.0	32.0
OPA4187IPWR	TSSOP	PW	14	2000	353.0	353.0	32.0
OPA4187IPWRG4	TSSOP	PW	14	2000	353.0	353.0	32.0
OPA4187IRUMR	WQFN	RUM	16	3000	367.0	367.0	35.0
OPA4187IRUMT	WQFN	RUM	16	250	210.0	185.0	35.0

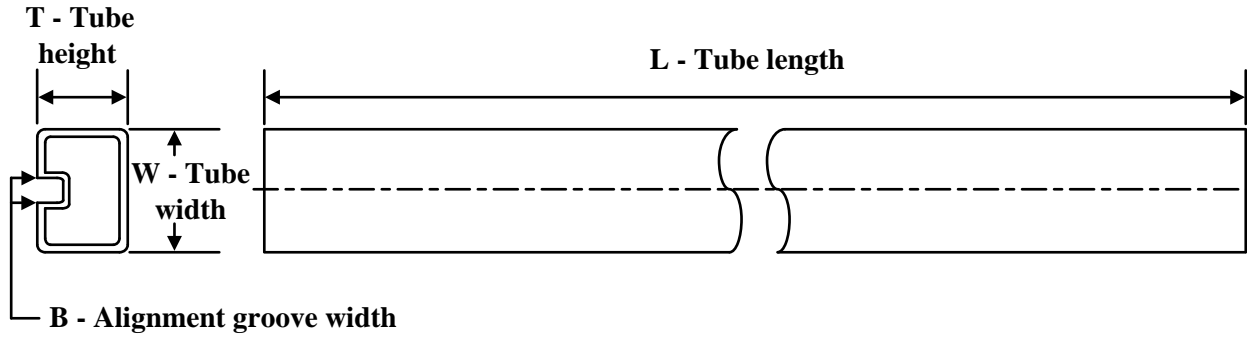
**TUBE**

\*All dimensions are nominal

Device	Package Name	Package Type	Pins	SPQ	L (mm)	W (mm)	T (μm)	B (mm)
OPA187ID	D	SOIC	8	75	506.6	8	3940	4.32
OPA187ID.B	D	SOIC	8	75	506.6	8	3940	4.32
OPA187IDG4	D	SOIC	8	75	506.6	8	3940	4.32
OPA187IDG4.B	D	SOIC	8	75	506.6	8	3940	4.32
OPA2187ID	D	SOIC	8	75	506.6	8	3940	4.32
OPA2187ID.B	D	SOIC	8	75	506.6	8	3940	4.32
OPA4187ID	D	SOIC	14	50	506.6	8	3940	4.32
OPA4187ID.B	D	SOIC	14	50	506.6	8	3940	4.32
OPA4187IDG4	D	SOIC	14	50	506.6	8	3940	4.32
OPA4187IDG4.B	D	SOIC	14	50	506.6	8	3940	4.32
OPA4187IPW	PW	TSSOP	14	90	530	10.2	3600	3.5
OPA4187IPW.B	PW	TSSOP	14	90	530	10.2	3600	3.5



# EXAMPLE BOARD LAYOUT

DBV0005A

SOT-23 - 1.45 mm max height

SMALL OUTLINE TRANSISTOR



LAND PATTERN EXAMPLE  
EXPOSED METAL SHOWN  
SCALE:15X



SOLDER MASK DETAILS

4214839/K 08/2024

NOTES: (continued)

- 6. Publication IPC-7351 may have alternate designs.
- 7. Solder mask tolerances between and around signal pads can vary based on board fabrication site.

# EXAMPLE STENCIL DESIGN

DBV0005A

SOT-23 - 1.45 mm max height

SMALL OUTLINE TRANSISTOR



SOLDER PASTE EXAMPLE  
BASED ON 0.125 mm THICK STENCIL  
SCALE:15X

4214839/K 08/2024

NOTES: (continued)

8. Laser cutting apertures with trapezoidal walls and rounded corners may offer better paste release. IPC-7525 may have alternate design recommendations.
9. Board assembly site may have different recommendations for stencil design.

# DGK0008A



# PACKAGE OUTLINE

VSSOP - 1.1 mm max height

SMALL OUTLINE PACKAGE



4214862/A 04/2023

**NOTES:**

PowerPAD is a trademark of Texas Instruments.

1. All linear dimensions are in millimeters. Any dimensions in parenthesis are for reference only. Dimensioning and tolerancing per ASME Y14.5M.
2. This drawing is subject to change without notice.
3. This dimension does not include mold flash, protrusions, or gate burrs. Mold flash, protrusions, or gate burrs shall not exceed 0.15 mm per side.
4. This dimension does not include interlead flash. Interlead flash shall not exceed 0.25 mm per side.
5. Reference JEDEC registration MO-187.

# EXAMPLE BOARD LAYOUT

DGK0008A

™ VSSOP - 1.1 mm max height

SMALL OUTLINE PACKAGE



LAND PATTERN EXAMPLE  
EXPOSED METAL SHOWN  
SCALE: 15X



SOLDER MASK DETAILS

4214862/A 04/2023

NOTES: (continued)

6. Publication IPC-7351 may have alternate designs.
7. Solder mask tolerances between and around signal pads can vary based on board fabrication site.
8. Vias are optional depending on application, refer to device data sheet. If any vias are implemented, refer to their locations shown on this view. It is recommended that vias under paste be filled, plugged or tented.
9. Size of metal pad may vary due to creepage requirement.

# EXAMPLE STENCIL DESIGN

DGK0008A

<sup>TM</sup> VSSOP - 1.1 mm max height

SMALL OUTLINE PACKAGE



SOLDER PASTE EXAMPLE  
SCALE: 15X

4214862/A 04/2023

NOTES: (continued)

11. Laser cutting apertures with trapezoidal walls and rounded corners may offer better paste release. IPC-7525 may have alternate design recommendations.
12. Board assembly site may have different recommendations for stencil design.



# D0014A

# PACKAGE OUTLINE

## SOIC - 1.75 mm max height

SMALL OUTLINE INTEGRATED CIRCUIT



4220718/A 09/2016

### NOTES:

1. All linear dimensions are in millimeters. Dimensions in parenthesis are for reference only. Dimensioning and tolerancing per ASME Y14.5M.
2. This drawing is subject to change without notice.
3. This dimension does not include mold flash, protrusions, or gate burrs. Mold flash, protrusions, or gate burrs shall not exceed 0.15 mm, per side.
4. This dimension does not include interlead flash. Interlead flash shall not exceed 0.43 mm, per side.
5. Reference JEDEC registration MS-012, variation AB.

# EXAMPLE BOARD LAYOUT

D0014A

SOIC - 1.75 mm max height

SMALL OUTLINE INTEGRATED CIRCUIT



LAND PATTERN EXAMPLE  
SCALE:8X



SOLDER MASK DETAILS

4220718/A 09/2016

NOTES: (continued)

- 6. Publication IPC-7351 may have alternate designs.
- 7. Solder mask tolerances between and around signal pads can vary based on board fabrication site.

# EXAMPLE STENCIL DESIGN

D0014A

SOIC - 1.75 mm max height

SMALL OUTLINE INTEGRATED CIRCUIT



SOLDER PASTE EXAMPLE  
BASED ON 0.125 mm THICK STENCIL  
SCALE:8X

4220718/A 09/2016

NOTES: (continued)

8. Laser cutting apertures with trapezoidal walls and rounded corners may offer better paste release. IPC-7525 may have alternate design recommendations.
9. Board assembly site may have different recommendations for stencil design.

## GENERIC PACKAGE VIEW

**RUM 16**

**WQFN - 0.8 mm max height**

4 x 4, 0.65 mm pitch

PLASTIC QUAD FLATPACK - NO LEAD

This image is a representation of the package family, actual package may vary.  
Refer to the product data sheet for package details.

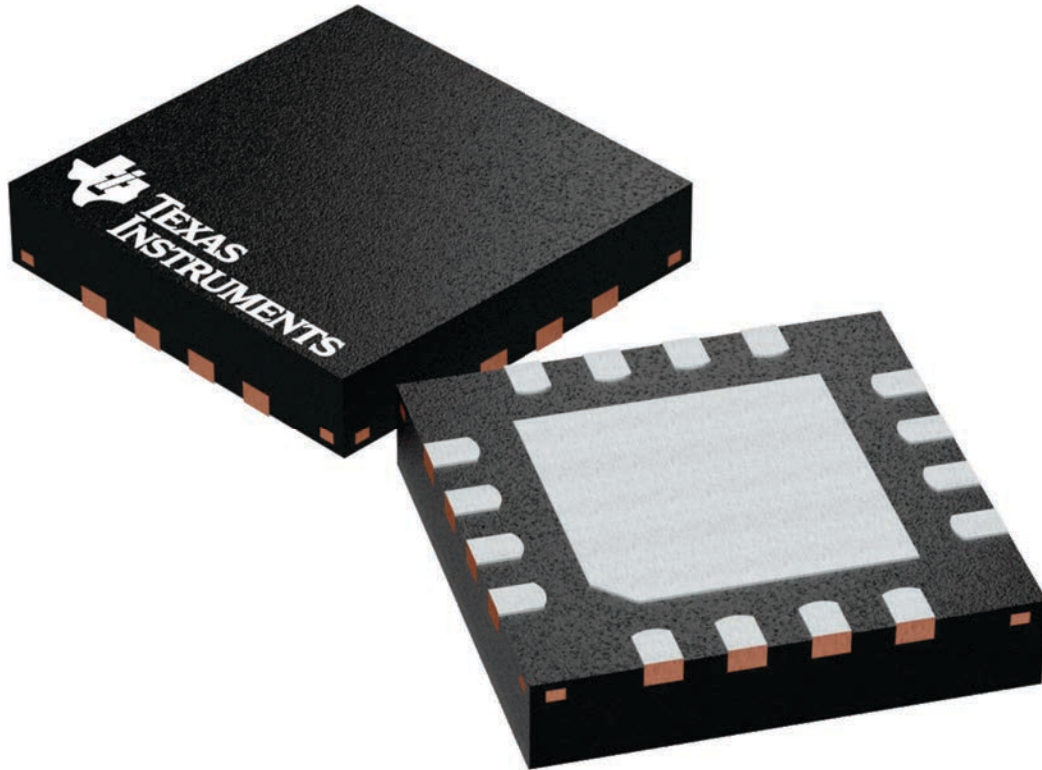

4224843/A

RUM (S-PQFP-N16)

PLASTIC QUAD FLATPACK

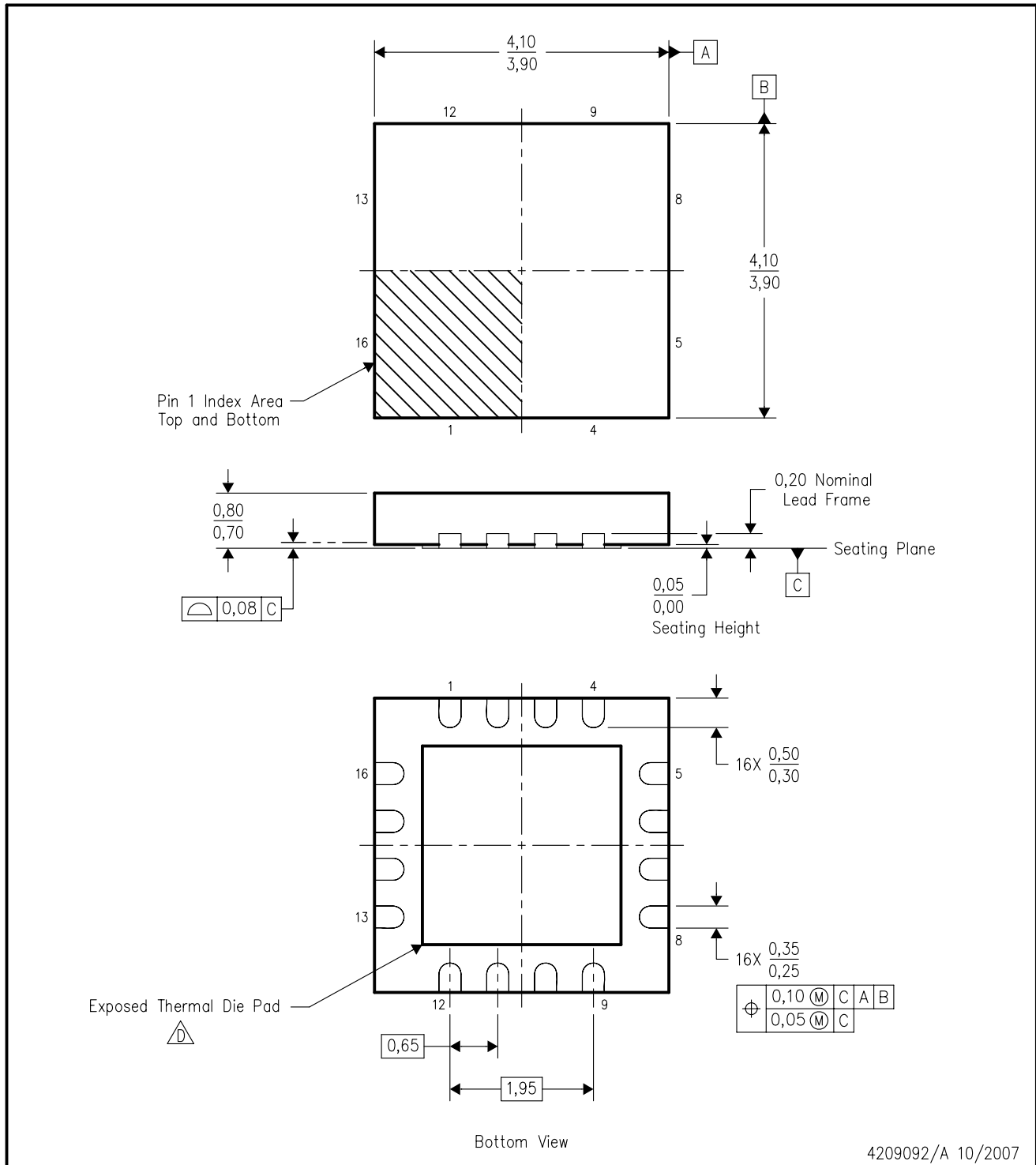

4209092/A 10/2007

- NOTES:
- A. All linear dimensions are in millimeters. Dimensioning and tolerancing per ASME Y14.5M-1994.
  - B. This drawing is subject to change without notice.
  - C. QFN (Quad Flatpack No-Lead) package configuration.
  -  The package thermal pad must be soldered to the board for thermal and mechanical performance. See the Product Data Sheet for details regarding the exposed thermal pad dimensions.
  - E. Package complies to JEDEC MO-220 variation WGGC-3.

**THERMAL INFORMATION**

This package incorporates an exposed thermal pad that is designed to be attached directly to an external heatsink. The thermal pad must be soldered directly to the printed circuit board (PCB). After soldering, the PCB can be used as a heatsink. In addition, through the use of thermal vias, the thermal pad can be attached directly to the appropriate copper plane shown in the electrical schematic for the device, or alternatively, can be attached to a special heatsink structure designed into the PCB. This design optimizes the heat transfer from the integrated circuit (IC).

For information on the Quad Flatpack No-Lead (QFN) package and its advantages, refer to Application Report, QFN/SON PCB Attachment, Texas Instruments Literature No. SLUA271. This document is available at [www.ti.com](http://www.ti.com).

The exposed thermal pad dimensions for this package are shown in the following illustration.

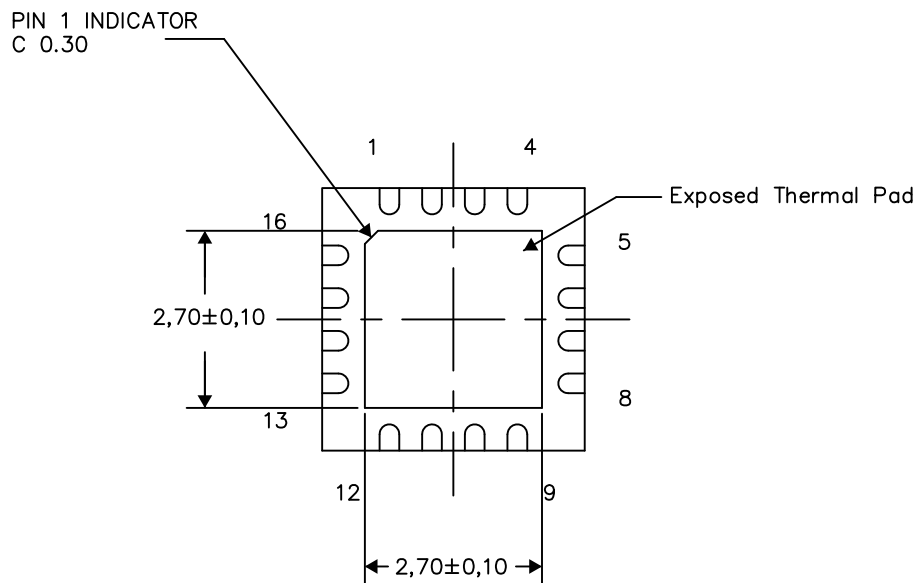

Bottom View

Exposed Thermal Pad Dimensions

4209093-2/F 09/15

NOTES: All linear dimensions are in millimeters



D0008A

# PACKAGE OUTLINE

SOIC - 1.75 mm max height

SMALL OUTLINE INTEGRATED CIRCUIT



4214825/C 02/2019

### NOTES:

- Linear dimensions are in inches [millimeters]. Dimensions in parenthesis are for reference only. Controlling dimensions are in inches. Dimensioning and tolerancing per ASME Y14.5M.
- This drawing is subject to change without notice.
- This dimension does not include mold flash, protrusions, or gate burrs. Mold flash, protrusions, or gate burrs shall not exceed  $.006$  [0.15] per side.
- This dimension does not include interlead flash.
- Reference JEDEC registration MS-012, variation AA.

# EXAMPLE BOARD LAYOUT

D0008A

SOIC - 1.75 mm max height

SMALL OUTLINE INTEGRATED CIRCUIT



LAND PATTERN EXAMPLE  
EXPOSED METAL SHOWN  
SCALE:8X



SOLDER MASK DETAILS

4214825/C 02/2019

NOTES: (continued)

6. Publication IPC-7351 may have alternate designs.

7. Solder mask tolerances between and around signal pads can vary based on board fabrication site.

# EXAMPLE STENCIL DESIGN

D0008A

SOIC - 1.75 mm max height

SMALL OUTLINE INTEGRATED CIRCUIT



SOLDER PASTE EXAMPLE  
BASED ON .005 INCH [0.125 MM] THICK STENCIL  
SCALE:8X

4214825/C 02/2019

NOTES: (continued)

8. Laser cutting apertures with trapezoidal walls and rounded corners may offer better paste release. IPC-7525 may have alternate design recommendations.
9. Board assembly site may have different recommendations for stencil design.



4220202/B 12/2023

NOTES:

1. All linear dimensions are in millimeters. Any dimensions in parenthesis are for reference only. Dimensioning and tolerancing per ASME Y14.5M.
2. This drawing is subject to change without notice.
3. This dimension does not include mold flash, protrusions, or gate burrs. Mold flash, protrusions, or gate burrs shall not exceed 0.15 mm per side.
4. This dimension does not include interlead flash. Interlead flash shall not exceed 0.25 mm per side.
5. Reference JEDEC registration MO-153.

# EXAMPLE BOARD LAYOUT

PW0014A

TSSOP - 1.2 mm max height

SMALL OUTLINE PACKAGE



LAND PATTERN EXAMPLE  
EXPOSED METAL SHOWN  
SCALE: 10X



4220202/B 12/2023

NOTES: (continued)

- 6. Publication IPC-7351 may have alternate designs.
- 7. Solder mask tolerances between and around signal pads can vary based on board fabrication site.

# EXAMPLE STENCIL DESIGN

PW0014A

TSSOP - 1.2 mm max height

SMALL OUTLINE PACKAGE



SOLDER PASTE EXAMPLE  
BASED ON 0.125 mm THICK STENCIL  
SCALE: 10X

4220202/B 12/2023

NOTES: (continued)

8. Laser cutting apertures with trapezoidal walls and rounded corners may offer better paste release. IPC-7525 may have alternate design recommendations.
9. Board assembly site may have different recommendations for stencil design.

## 重要なお知らせと免責事項

TI は、技術データと信頼性データ (データシートを含みます)、設計リソース (リファレンス デザインを含みます)、アプリケーションや設計に関する各種アドバイス、Web ツール、安全性情報、その他のリソースを、欠陥が存在する可能性のある「現状のまま」提供しており、商品性および特定目的に対する適合性の黙示保証、第三者の知的財産権の非侵害保証を含むいかなる保証も、明示的または黙示的にかかわらず拒否します。

これらのリソースは、TI 製品を使用する設計の経験を積んだ開発者への提供を意図したものです。(1) お客様のアプリケーションに適した TI 製品の選定、(2) お客様のアプリケーションの設計、検証、試験、(3) お客様のアプリケーションに該当する各種規格や、その他のあらゆる安全性、セキュリティ、規制、または他の要件への確実な適合に関する責任を、お客様のみが単独で負うものとし、

上記の各種リソースは、予告なく変更される可能性があります。これらのリソースは、リソースで説明されている TI 製品を使用するアプリケーションの開発の目的でのみ、TI はその使用をお客様に許諾します。これらのリソースに関して、他の目的で複製することや掲載することは禁止されています。TI や第三者の知的財産権のライセンスが付与されている訳ではありません。お客様は、これらのリソースを自身で使用した結果発生するあらゆる申し立て、損害、費用、損失、責任について、TI およびその代理人を完全に補償するものとし、TI は一切の責任を拒否します。

TI の製品は、[TI の販売条件](#)、[TI の総合的な品質ガイドライン](#)、[ti.com](#) または TI 製品などに関連して提供される他の適用条件に従い提供されます。TI がこれらのリソースを提供することは、適用される TI の保証または他の保証の放棄の拡大や変更を意味するものではありません。TI がカスタム、またはカスタマー仕様として明示的に指定していない限り、TI の製品は標準的なカタログに掲載される汎用機器です。

お客様がいかなる追加条項または代替条項を提案する場合も、TI はそれらに異議を唱え、拒否します。

Copyright © 2026, Texas Instruments Incorporated

最終更新日 : 2025 年 10 月