

# OPAx320-Q1 高精度、20MHz、0.9pA、低ノイズ、RRIO の CMOS オペアンプ

## 1 特長

- 車載アプリケーションに対応
- 下記内容でAEC-Q100認定済み
  - デバイス温度グレード1: 動作時周囲温度範囲  $-40^{\circ}\text{C} \sim 125^{\circ}\text{C}$
  - デバイスHBM ESD分類レベル2
  - デバイスCDM ESD分類レベルC4B
- ゼロ・クロスオーバー歪みで高精度
  - 低いオフセット電圧:  $150\mu\text{V}$  (最大値)
  - 高いCMRR: 114dB
  - レール・ツー・レールI/O
- 低い入力バイアス電流:  $0.9\text{pA}$  (最大値)
- 低ノイズ:  $7\text{nV}/\sqrt{\text{Hz}}$  (10kHz 時)
- 広い帯域幅: 20MHz
- スルーレート:  $10\text{V}/\mu\text{s}$
- 静止電流:  $1.45\text{mA}/\text{ch}$
- 単一電源電圧範囲:  $1.8 \sim 5.5\text{V}$
- ユニティ・ゲイン安定
- 小型の VSSOP パッケージ

## 2 アプリケーション

- 車載用
- 高インピーダンス・センサ信号調節
- トランスインピーダンス・アンプ
- テストおよび計測機器
- プログラマブル・ロジック・コントローラ(PLC)
- モータ制御ループ
- 通信
- 入力および出力 ADC および DAC バッファ
- アクティブ・フィルタ

### ゼロ・クロスオーバー歪み: 低オフセット電圧

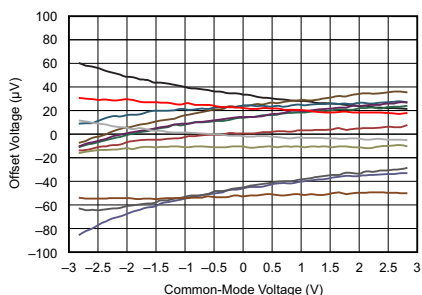

## 3 概要

OPA320-Q1 および OPA2320-Q1 (OPAx320-Q1) デバイスは、非常に低いノイズと広い帯域幅のために最適化された、新世代の高精度低電圧 CMOS 演算増幅器 (オペアンプ) です。これらのデバイスは、わずか  $1.45\text{mA}$  の小さな静止電流で動作します。

OPAx320-Q1 は、低消費電力、単一電源のアプリケーションに極めて適した選択肢です。低ノイズ ( $7\text{nV}/\sqrt{\text{Hz}}$ ) と高速での動作により、これらのデバイスはサンプリング A/D コンバータ (ADC) の駆動にも適しています。他の用途として、信号コンディショニングやセンサ・アンプにも使用できます。

OPAx320-Q1 のリニア入力段はゼロ・クロスオーバー歪みを特長とし、入力範囲全体で 114dB (標準値) の優れた同相除去比 (CMRR) を実現しています。入力同相範囲は、負および正の電源レールよりも  $100\text{mV}$  拡張されています。出力電圧のスイングは通常、レールから  $10\text{mV}$  の範囲内です。

さらに、OPAx320-Q1 は電源電圧範囲が  $1.8\text{V} \sim 5.5\text{V}$  と広く、電源電圧範囲全体にわたって非常に優れた PSRR (106dB) を備えています。これらの特長から OPAx320-Q1 は、レギュレーションなしで直接バッテリーから動作する高精度低消費電力アプリケーションに適しています。

OPAx320-Q1 デバイスは、8 ピン VSSOP (DGK) パッケージで供給されます。

### 製品情報<sup>(1)</sup>

| 型番         | パッケージ     | 本体サイズ(公称)       |
|------------|-----------|-----------------|
| OPA320-Q1  | SOT (5)   | 2.90mm x 1.60mm |
| OPA2320-Q1 | VSSOP (8) | 3.00mm x 3.00mm |

(1) 利用可能なすべてのパッケージについては、このデータシートの末尾にあるパッケージ・オプションについての付録を参照してください。

## 目次

|     |                                  |    |      |                                |    |
|-----|----------------------------------|----|------|--------------------------------|----|
| 1   | 特長                               | 1  | 8    | Application and Implementation | 17 |
| 2   | アプリケーション                         | 1  | 8.1  | Application Information        | 17 |
| 3   | 概要                               | 1  | 8.2  | Typical Applications           | 17 |
| 4   | 改訂履歴                             | 2  | 9    | Power Supply Recommendations   | 22 |
| 5   | Pin Configuration and Functions  | 3  | 10   | Layout                         | 22 |
| 6   | Specifications                   | 4  | 10.1 | Layout Guidelines              | 22 |
| 6.1 | Absolute Maximum Ratings         | 4  | 10.2 | Layout Example                 | 23 |
| 6.2 | ESD Ratings                      | 4  | 11   | デバイスおよびドキュメントのサポート             | 24 |
| 6.3 | Recommended Operating Conditions | 4  | 11.1 | デバイス・サポート                      | 24 |
| 6.4 | Thermal Information              | 4  | 11.2 | 関連リンク                          | 24 |
| 6.5 | Electrical Characteristics       | 5  | 11.3 | ドキュメントの更新通知を受け取る方法             | 24 |
| 6.6 | Typical Characteristics          | 7  | 11.4 | コミュニティ・リソース                    | 24 |
| 7   | Detailed Description             | 12 | 11.5 | 商標                             | 24 |
| 7.1 | Overview                         | 12 | 11.6 | 静電気放電に関する注意事項                  | 24 |
| 7.2 | Functional Block Diagram         | 12 | 11.7 | Glossary                       | 25 |
| 7.3 | Feature Description              | 13 | 12   | メカニカル、パッケージ、および注文情報            | 25 |
| 7.4 | Device Functional Modes          | 16 |      |                                |    |

## 4 改訂履歴

### Revision A (December 2016) から Revision B に変更

Page

|   |  |    |
|---|--|----|
| • | Changed Figure 1 x-axis unit from mV to $\mu$ V (typo)       | 7  |
| • | Changed Figure 2 x-axis unit from mV/°C to $\mu$ V/°C (typo) | 7  |
| • | Changed Figure 3 y-axis unit from mV to $\mu$ V (typo)       | 7  |
| • | Changed Figure 14 y-axis unit from mV to $\mu$ V (typo)      | 8  |
| • | Changed Figure 19 y-axis unit from W to $\Omega$ (typo)      | 9  |
| • | Changed Figure 25 y-axis unit from V/ms to V/ $\mu$ s (typo) | 10 |
| • | Changed Figure 26 x-axis unit from ms to $\mu$ s (typo)      | 10 |
| • | Changed Figure 27 x-axis unit from ms to $\mu$ s (typo)      | 10 |
| • | Changed Figure 28 x-axis unit from ms to $\mu$ s (typo)      | 10 |
| • | Changed Figure 35 x-axis unit from ms to $\mu$ s (typo)      | 16 |

### 2014年9月発行のものから更新

Page

|   |  |    |
|---|--|----|
| • | OPA320-Q1 デバイスをドキュメントに追加   | 1  |
| • | ドキュメント全体で、両方のデバイスが言及されている場所で OPA2320-Q1 を OPAX320-Q1 に変更   | 1  |
| • | 「(OPA320-Q1, OPA2320-Q1)」を追加し、「概要」セクションの最初の文を変更  | 1  |
| • | 「製品情報」表に OPA320-Q1 を追加   | 1  |
| • | Added OPA320-Q1 device (SOT package) to <i>Pin Configuration and Functions</i> section: added OPA320-Q1 pin out to section and added relevant rows to <i>Pin Functions</i> table | 3  |
| • | Changed format of <i>ESD Ratings</i> table: updated table to current standards, moved storage temperature parameter to <i>Absolute Maximum Ratings</i> table                     | 4  |
| • | Changed <i>Supply voltage</i> parameter in <i>Recommended Operating Conditions</i> table: split apart single- and dual-supply values into separate rows                          | 4  |
| • | Added OPA320-Q1 package to <i>Thermal Information</i> table  | 4  |
| • | Changed <i>Output Voltage Swing vs Output Current</i> figure   | 8  |
| • | Changed <i>Operational Amplifier Board Layout for Noninverting Configuration</i> figure  | 23 |

## 5 Pin Configuration and Functions

**OPA320-Q1: DBV Package  
5-Pin SOT  
Top View**

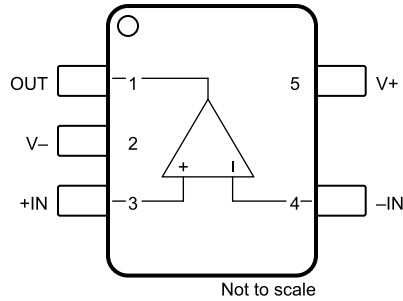

**OPA2320-Q1: DGK Package  
8-Pin VSSOP  
Top View**

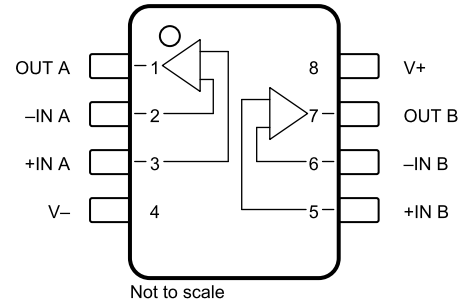

### Pin Functions

| NAME  | PIN NO. |     | I/O | DESCRIPTION   |
|-------|---------|-----|-----|---|
|       | DBV     | DGK |     |   |
| -IN   | 4       | —   | I   | Inverting input   |
| -IN A | —       | 2   | I   | Inverting input (channel A)                             |
| -IN B | —       | 6   | I   | Inverting input (channel B)                             |
| +IN   | 3       | —   | I   | Noninverting input                                      |
| +IN A | —       | 3   | I   | Noninverting input (channel A)                          |
| +IN B | —       | 5   | I   | Noninverting input (channel B)                          |
| OUT   | 1       | —   | O   | Output  |
| OUT A | —       | 1   | O   | Output (channel A)                                      |
| OUT B | —       | 7   | O   | Output (channel B)                                      |
| V-    | 2       | 4   | —   | Negative supply or ground (for single-supply operation) |
| V+    | 5       | 8   | —   | Positive supply   |

## 6 Specifications

### 6.1 Absolute Maximum Ratings

over operating free-air temperature range (unless otherwise noted)<sup>(1)</sup>

|                        |   | MIN              | MAX              | UNIT |
|------------------------|---|------------------|------------------|------|
| Supply voltage         | V+ and V–                                   | 6                |                  | V    |
| Voltage <sup>(2)</sup> | Signal input pins                           | $V_{(V-)} - 0.5$ | $V_{(V+)} + 0.5$ | V    |
| Current <sup>(2)</sup> | Signal input pins                           | –10              | 10               | mA   |
|                        | Output short-circuit current <sup>(3)</sup> | Continuous       |                  |      |
| Temperature            | Operating, T <sub>A</sub>                   | –40              | 150              | °C   |
|                        | Junction, T <sub>J</sub>                    | 150              |                  |      |
|                        | Storage, T <sub>stg</sub>                   | –65              | 150              |      |

- (1) Stresses beyond those listed as *absolute maximum ratings* may cause permanent damage to the device. These are stress ratings only, and functional operation of the device at these or any other conditions beyond those indicated as *recommended operating conditions* is not implied. Exposure to absolute-maximum-rated conditions for extended periods may affect device reliability.
- (2) Input terminals are diode-clamped to the power-supply rails. Input signals that can swing more than 0.5 V beyond the supply rails should be current limited to 10 mA or less.
- (3) Short-circuit to ground, one amplifier per package.

### 6.2 ESD Ratings

|                    |                         |   | VALUE                        | UNIT |      |
|--------------------|-------------------------|---|------------------------------|------|------|
| V <sub>(ESD)</sub> | Electrostatic discharge | Human-body model (HBM), per AEC Q100-002 <sup>(1)</sup> | ±2000                        | V    |      |
|                    |                         | Charged-device model (CDM), per AEC Q100-011            | All pins                     |      | ±500 |
|                    |                         |   | Corner pins (1, 4, 5, and 8) |      | ±750 |

- (1) AEC Q100-002 indicates that HBM stressing shall be in accordance with the ANSI/ESDA/JEDEC JS-001 specification.

### 6.3 Recommended Operating Conditions

over operating free-air temperature range (unless otherwise noted)

|                |                               | MIN           | NOM  | MAX   | UNIT |
|----------------|-------------------------------|---------------|------|-------|------|
| V <sub>S</sub> | Supply voltage                | Single-supply | 1.8  | 5.5   | V    |
|                |                               | Dual-supply   | ±0.9 | ±2.75 |      |
| T <sub>A</sub> | Ambient operating temperature | –40           |      | 125   | °C   |

### 6.4 Thermal Information

| THERMAL METRIC <sup>(1)</sup> |  | OPA320-Q1 | OPA2320-Q1  | UNIT |
|-------------------------------|--|-----------|-------------|------|
|                               |  | DBV (SOT) | DGK (VSSOP) |      |
|                               |  | 5 PINS    | 8 PINS      |      |
| R <sub>θJA</sub>              | Junction-to-ambient thermal resistance       | 158.8     | 174.8       | °C/W |
| R <sub>θJC(top)</sub>         | Junction-to-case (top) thermal resistance    | 60.7      | 43.9        | °C/W |
| R <sub>θJB</sub>              | Junction-to-board thermal resistance         | 44.8      | 95          | °C/W |
| ψ <sub>JT</sub>               | Junction-to-top characterization parameter   | 1.6       | 2           | °C/W |
| ψ <sub>JB</sub>               | Junction-to-board characterization parameter | 4.2       | 93.5        | °C/W |
| R <sub>θJC(bot)</sub>         | Junction-to-case (bottom) thermal resistance | —         | —           | °C/W |

- (1) For more information about traditional and new thermal metrics, see the [Semiconductor and IC Package Thermal Metrics](#) application report.

## 6.5 Electrical Characteristics:

$V_S = 1.8$  to  $5.5$  V or  $\pm 0.9$  V to  $\pm 2.75$  V; at  $T_A = 25^\circ\text{C}$ ,  $R_{(L)} = 10$  k $\Omega$  connected to  $V_S / 2$ ,  $V_{(CM)} = V_S / 2$ ,  $V_O = V_S / 2$  (unless otherwise noted)

| PARAMETER  |  | TEST CONDITIONS   | MIN              | TYP              | MAX       | UNIT                         |
|--|--|---|------------------|------------------|-----------|------------------------------|
| <b>OFFSET VOLTAGE</b>  |  |   |                  |                  |           |                              |
| $V_{IO}$   | Input offset voltage                             |   |                  | 40               | 150       | $\mu\text{V}$                |
|  | Input offset voltage versus temperature          | $V_S = 5.5$ V, $T_A = -40^\circ\text{C}$ to $+125^\circ\text{C}$  |                  | 1.5              | 5         | $\mu\text{V}/^\circ\text{C}$ |
|  | Input offset voltage versus power supply         | $V_S = 1.8$ to $5.5$ V  |                  | 5                | 20        | $\mu\text{V}/\text{V}$       |
|  |  | $V_S = 1.8$ to $5.5$ V, $T_A = -40^\circ\text{C}$ to $+125^\circ\text{C}$   |                  | 15               |           |                              |
|  | Input offset-voltage channel separation          | At 1 kHz  |                  | 130              |           | dB                           |
| <b>INPUT VOLTAGE</b>   |  |   |                  |                  |           |                              |
| $V_{(CM)}$   | Common-mode voltage range                        |   | $V_{(V-)} - 0.1$ | $V_{(V+)} + 0.1$ |           | V                            |
| CMRR   | Common-mode rejection ratio                      | $V_S = 5.5$ V, $V_{(V-)} - 0.1$ V $<$ $V_{(CM)} <$ $V_{(V+)} + 0.1$ V   | 100              | 114              |           | dB                           |
|  | Common-mode rejection ratio, over temperature    | $V_S = 5.5$ V, $V_{(V-)} - 0.1$ V $<$ $V_{(CM)} <$ $V_{(V+)} + 0.1$ V, $T_A = -40^\circ\text{C}$ to $125^\circ\text{C}$ | 96               |                  |           | dB                           |
| <b>INPUT BIAS CURRENT</b>  |  |   |                  |                  |           |                              |
| $I_{IB}$   | Input bias current                               |   |                  | $\pm 0.2$        | $\pm 0.9$ | pA                           |
|  | Input bias current, over temperature             | $T_A = -40^\circ\text{C}$ to $85^\circ\text{C}$   |                  |                  | $\pm 50$  | pA                           |
|  |  | $T_A = -40^\circ\text{C}$ to $125^\circ\text{C}$  |                  |                  | $\pm 400$ |                              |
| $I_{IO}$   | Input offset current                             |   |                  | $\pm 0.2$        | $\pm 0.9$ | pA                           |
|  | Input offset current, over temperature           | $T_A = -40^\circ\text{C}$ to $85^\circ\text{C}$   |                  |                  | $\pm 50$  | pA                           |
|  |  | $T_A = -40^\circ\text{C}$ to $125^\circ\text{C}$  |                  |                  | $\pm 400$ |                              |
| <b>NOISE</b>   |  |   |                  |                  |           |                              |
| $V_{(n)}$  | Input voltage noise                              | $f = 0.1$ to $10$ Hz  |                  | 2.8              |           | $\mu\text{V}_{PP}$           |
|  | Input voltage noise density                      | $f = 1$ kHz   |                  | 8.5              |           | $\text{nV}/\sqrt{\text{Hz}}$ |
|  |  | $f = 10$ kHz  |                  | 7                |           |                              |
|  | Input current noise density                      | $f = 1$ kHz   |                  | 0.6              |           | $\text{fA}/\sqrt{\text{Hz}}$ |
| <b>INPUT CAPACITANCE</b>   |  |   |                  |                  |           |                              |
|  | Differential                                     |   |                  | 5                |           | pF                           |
|  | Common-mode                                      |   |                  | 4                |           | pF                           |
| <b>OPEN-LOOP GAIN</b>  |  |   |                  |                  |           |                              |
| $A_{(OL)}$   | Open-loop voltage gain                           | $0.1$ V $<$ $V_O <$ $V_{(V+)} - 0.1$ V, $R_{(L)} = 10$ k $\Omega$   | 114              | 132              |           | dB                           |
|  |  | $0.1$ V $<$ $V_O <$ $V_{(V+)} - 0.1$ V, $R_{(L)} = 10$ k $\Omega$ , $T_A = -40^\circ\text{C}$ to $125^\circ\text{C}$    | 100              | 130              |           |                              |
|  |  | $0.2$ V $<$ $V_O <$ $V_{(V+)} - 0.2$ V, $R_{(L)} = 2$ k $\Omega$  | 108              | 123              |           |                              |
|  |  | $0.2$ V $<$ $V_O <$ $V_{(V+)} - 0.2$ V, $R_{(L)} = 2$ k $\Omega$ , $T_A = -40^\circ\text{C}$ to $125^\circ\text{C}$     | 96               | 130              |           |                              |
| PM   | Phase margin                                     | $V_S = 5$ V, $C_{(L)} = 50$ pF  |                  | 47               |           | $^\circ$                     |
| <b>FREQUENCY RESPONSE (<math>V_S = 5</math> V, <math>C_{(L)} = 50</math> pF)</b> |  |   |                  |                  |           |                              |
| GBP  | Gain bandwidth product                           | Unity gain  |                  | 20               |           | MHz                          |
| SR   | Slew rate  | $G = 1$   |                  | 10               |           | V/ $\mu\text{s}$             |
| $t_s$  | Settling time                                    | To 0.1%, 2-V step, $G = 1$  |                  | 0.25             |           | $\mu\text{s}$                |
|  |  | To 0.01%, 2-V step, $G = 1$   |                  | 0.32             |           |                              |
|  |  | To 0.0015%, 2-V step, $G = 1^{(1)}$   |                  | 0.5              |           |                              |
|  | Overload recovery time                           | $V_I \times G > V_S$  |                  | 100              |           | ns                           |
| THD+N  | Total harmonic distortion + noise <sup>(2)</sup> | $V_O = 4$ V <sub>PP</sub> , $G = 1$ , $f = 10$ kHz, $R_{(L)} = 10$ k $\Omega$   |                  | 0.0005%          |           |                              |
|  |  | $V_O = 4$ V <sub>PP</sub> , $G = 1$ , $f = 10$ kHz, $R_{(L)} = 600$ k $\Omega$  |                  | 0.0011%          |           |                              |

(1) Based on simulation.

(2) Third-order filter; bandwidth = 80 kHz at  $-3$  dB.

**Electrical Characteristics: (continued)**

$V_S = 1.8$  to  $5.5$  V or  $\pm 0.9$  V to  $\pm 2.75$  V; at  $T_A = 25^\circ\text{C}$ ,  $R_{(L)} = 10$  k $\Omega$  connected to  $V_S / 2$ ,  $V_{(CM)} = V_S / 2$ ,  $V_O = V_S / 2$  (unless otherwise noted)

| PARAMETER           |                                      | TEST CONDITIONS   | MIN   | TYP      | MAX | UNIT             |
|---------------------|--------------------------------------|---|---|----------|-----|------------------|
| <b>OUTPUT</b>       |                                      |   |   |          |     |                  |
| $V_O$               | Voltage output swing from both rails | $R_{(L)} = 10$ k $\Omega$   |   | 10       | 20  | mV               |
|                     |                                      | $R_{(L)} = 10$ k $\Omega$ , $T_A = -40^\circ\text{C}$ to $125^\circ\text{C}$  |   |          | 30  |                  |
|                     |                                      | $R_{(L)} = 2$ k $\Omega$  |   | 25       | 35  |                  |
|                     |                                      | $R_{(L)} = 2$ k $\Omega$ , $T_A = -40^\circ\text{C}$ to $125^\circ\text{C}$   |   |          | 45  |                  |
| $I_{(SC)}$          | Short-circuit current                | $V_S = 5.5$ V   |   | $\pm 65$ |     | mA               |
| $C_{(L)}$           | Capacitive load drive                |   | See <a href="#">Typical Characteristics</a> |          |     |                  |
|                     | Open-loop output resistance          | $I_O = 0$ mA, $f = 1$ MHz   |   | 90       |     | $\Omega$         |
| <b>POWER SUPPLY</b> |                                      |   |   |          |     |                  |
| $V_S$               | Specified voltage range              |   | 1.8   |          | 5.5 | V                |
| $I_Q$               | Quiescent current per amplifier      | $I_O = 0$ mA, $V_S = 5.5$ V   |   | 1.45     | 1.6 | mA               |
|                     |                                      | $I_O = 0$ mA, $V_S = 5.5$ V, $T_A = -40^\circ\text{C}$ to $125^\circ\text{C}$ |   |          | 1.7 |                  |
|                     | Power-on time                        | $V_{(V+)} = 0$ to $5$ V, to 90% $I_Q$ level                                   |   | 28       |     | $\mu\text{s}$    |
| <b>TEMPERATURE</b>  |                                      |   |   |          |     |                  |
|                     | Specified range                      |   | -40   |          | 125 | $^\circ\text{C}$ |
|                     | Operating range                      |   | -40   |          | 150 | $^\circ\text{C}$ |

### 6.6 Typical Characteristics

at  $T_A = 25^\circ\text{C}$ ,  $V_{(CM)} = V_O = \text{mid-supply}$ , and  $R_{(L)} = 10\text{ k}\Omega$  (unless otherwise noted)

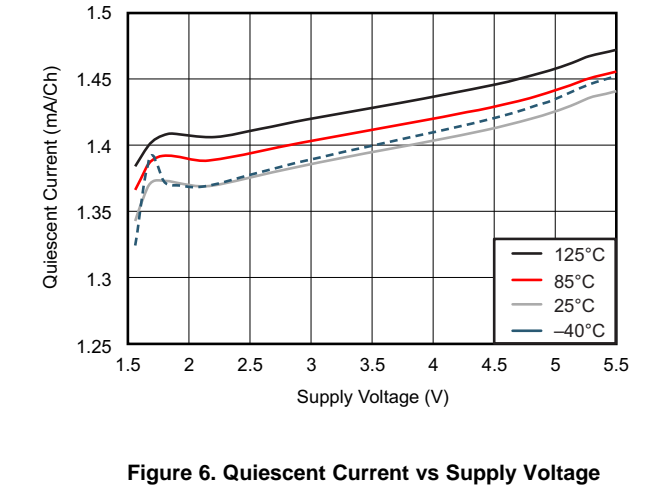
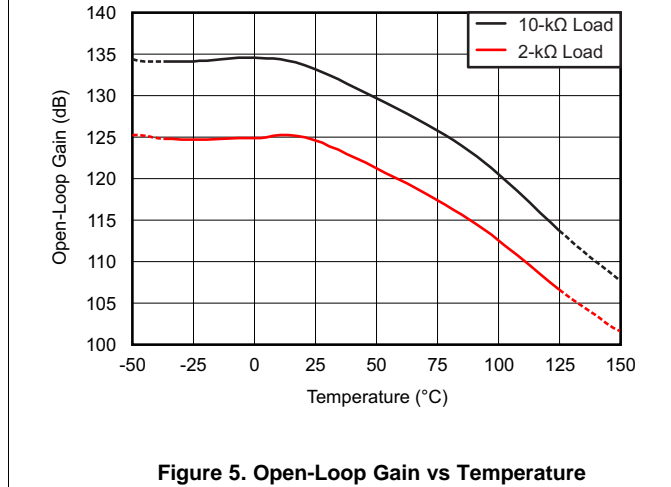
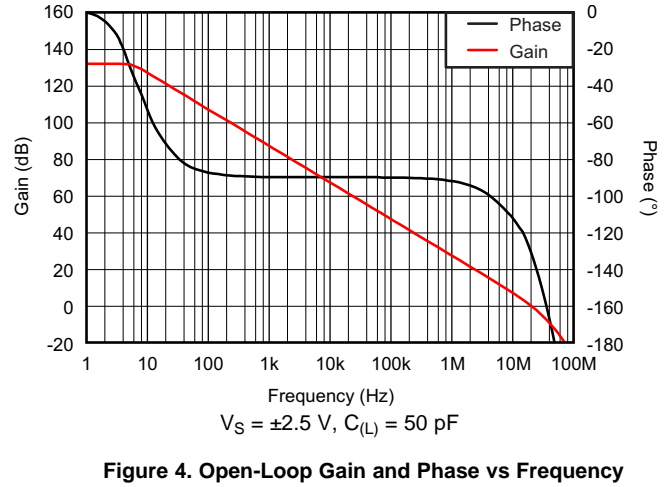
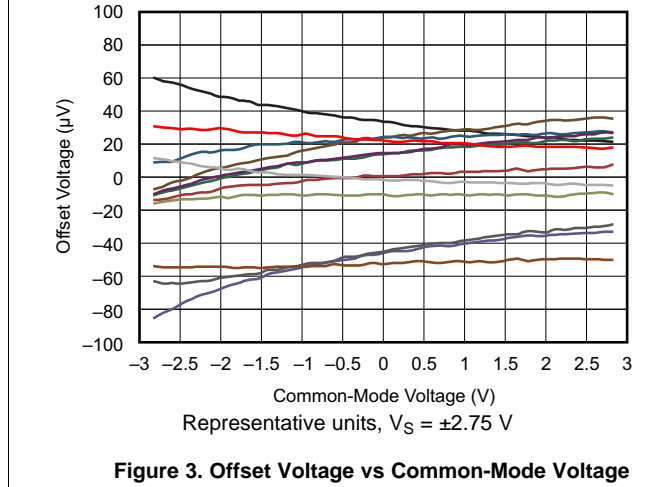
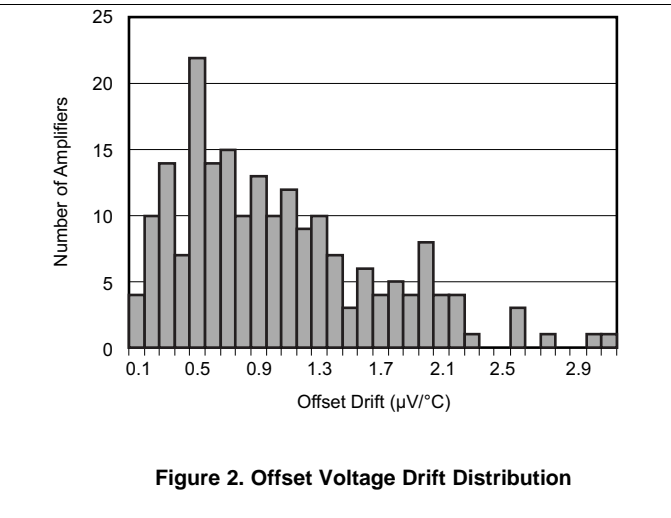
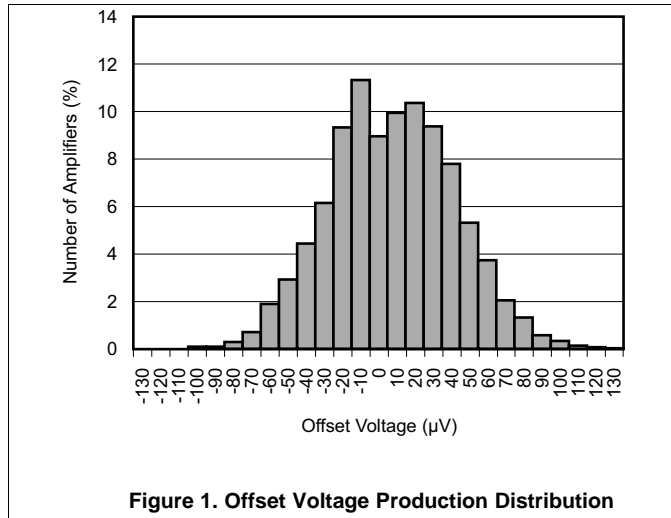

Typical Characteristics (continued)

at  $T_A = 25^\circ\text{C}$ ,  $V_{(CM)} = V_O = \text{mid-supply}$ , and  $R_{(L)} = 10\text{ k}\Omega$  (unless otherwise noted)

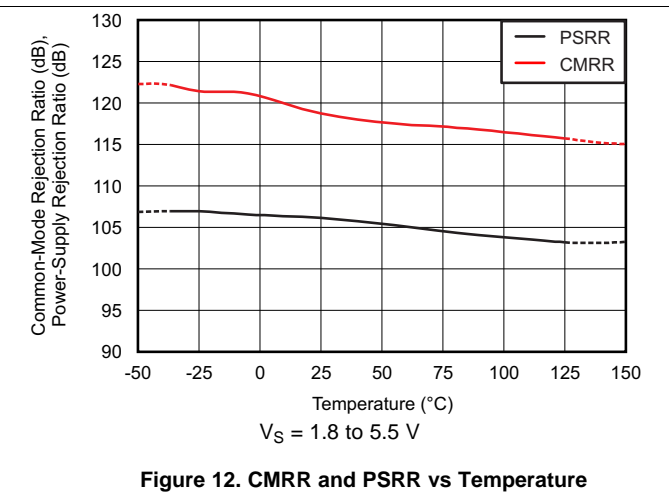
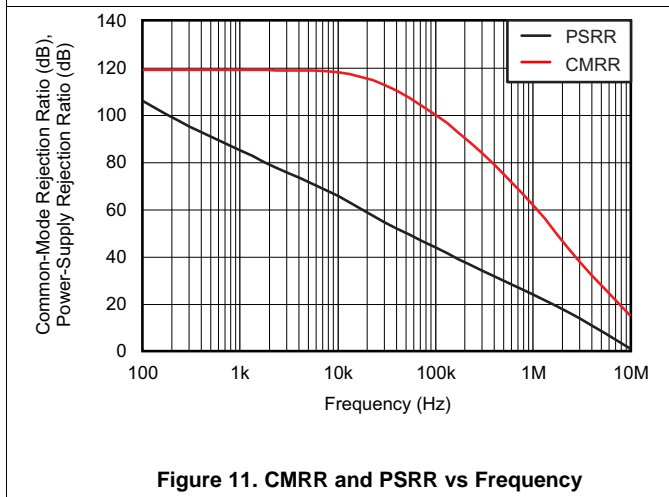
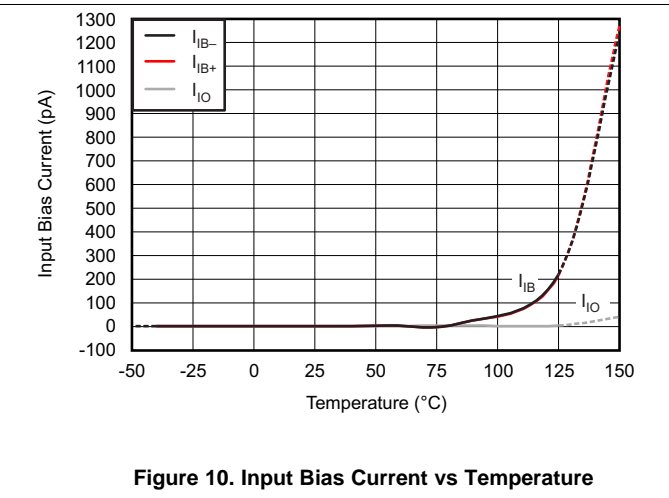
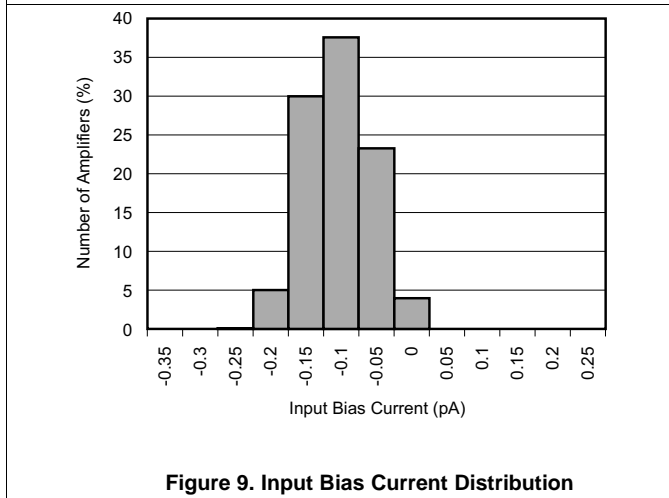
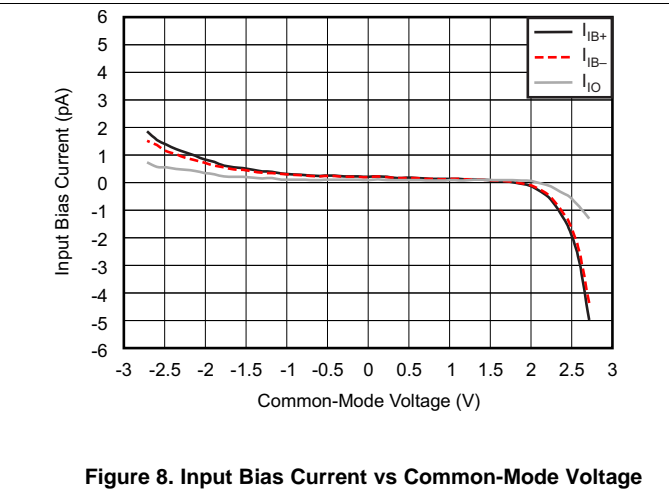
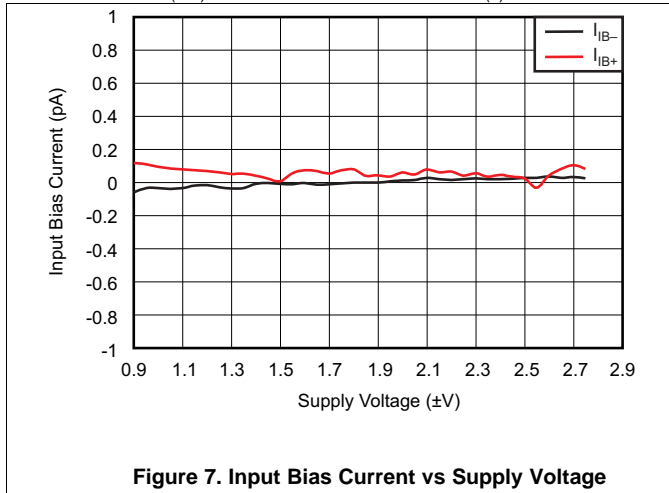

Typical Characteristics (continued)

at  $T_A = 25^\circ\text{C}$ ,  $V_{(CM)} = V_O = \text{mid-supply}$ , and  $R_{(L)} = 10\text{ k}\Omega$  (unless otherwise noted)

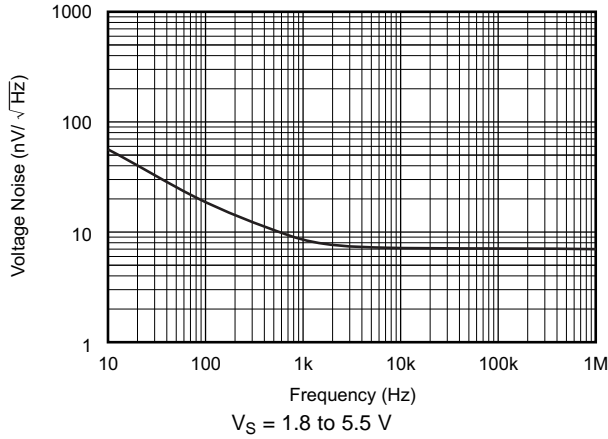

Figure 13. Input Voltage Noise Spectral Density vs Frequency

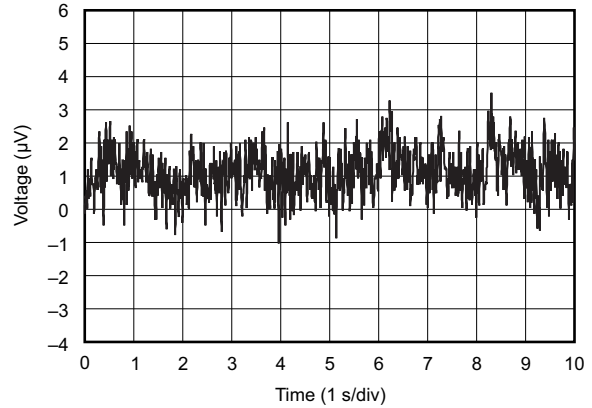

Figure 14. 0.1-Hz to 10-Hz Input Voltage Noise

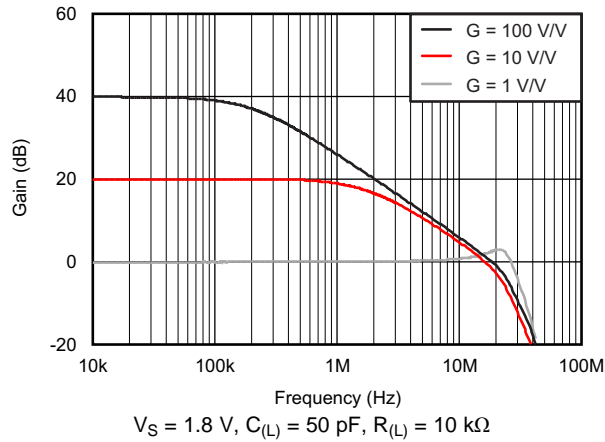

Figure 15. Closed-Loop Gain vs Frequency

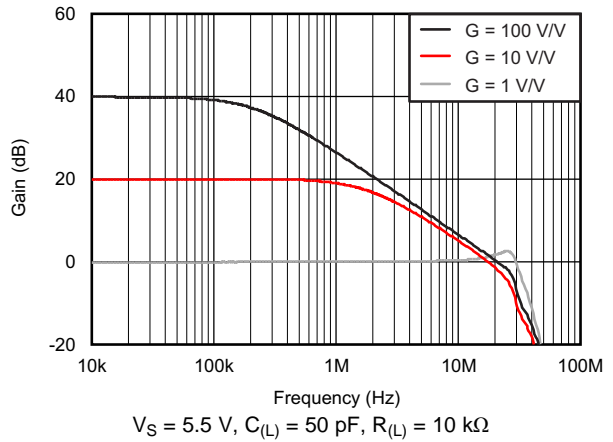

Figure 16. Closed-Loop Gain vs Frequency

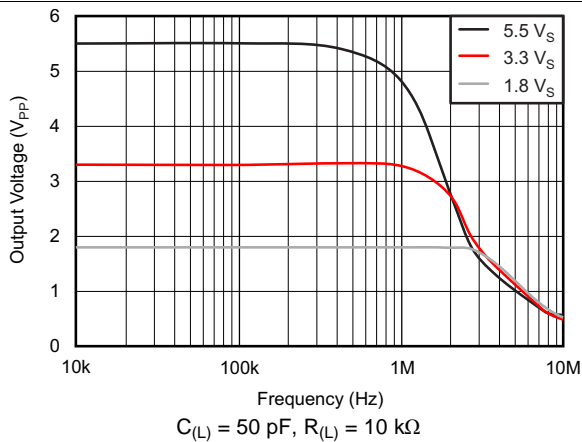

Figure 17. Maximum Output Voltage vs Frequency

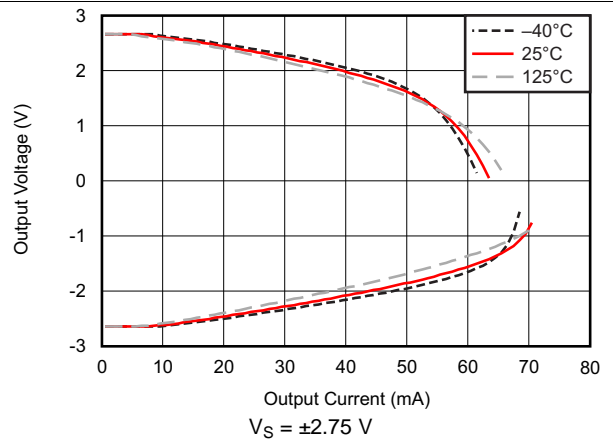

Figure 18. Output Voltage Swing vs Output Current

Typical Characteristics (continued)

at  $T_A = 25^\circ\text{C}$ ,  $V_{(CM)} = V_O = \text{mid-supply}$ , and  $R_{(L)} = 10\text{ k}\Omega$  (unless otherwise noted)

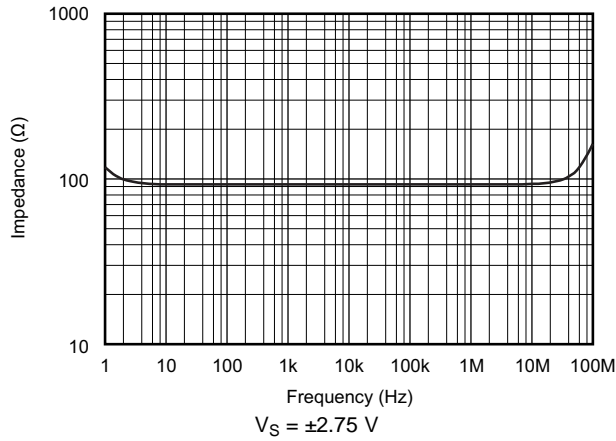

Figure 19. Open-Loop Output Impedance vs Frequency

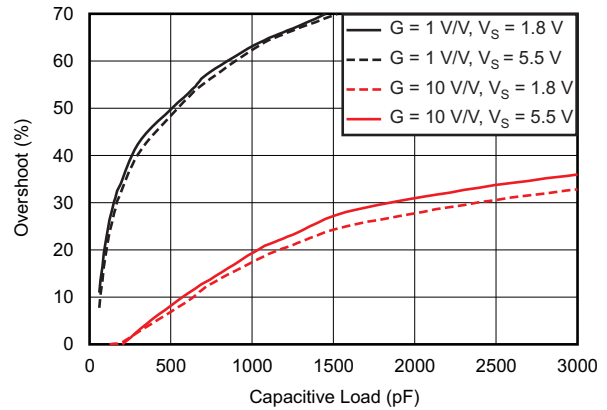

Figure 20. Small-Signal Overshoot vs Load Capacitance

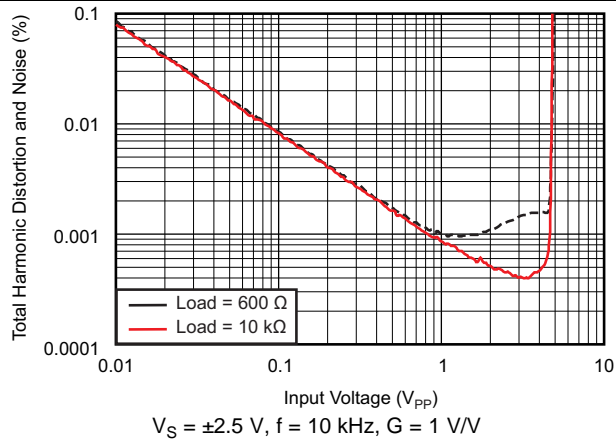

Figure 21. THD+N vs Amplitude

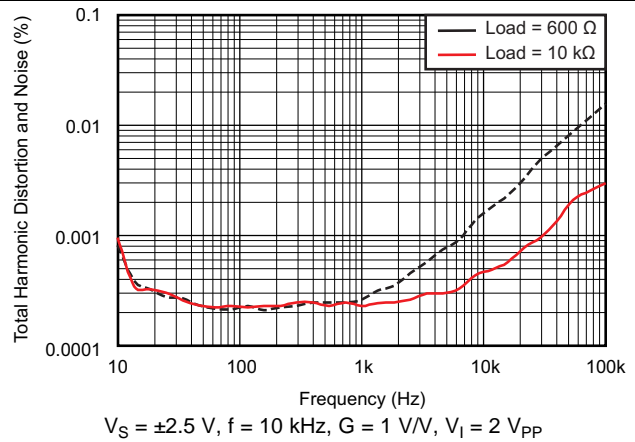

Figure 22. THD+N vs Frequency

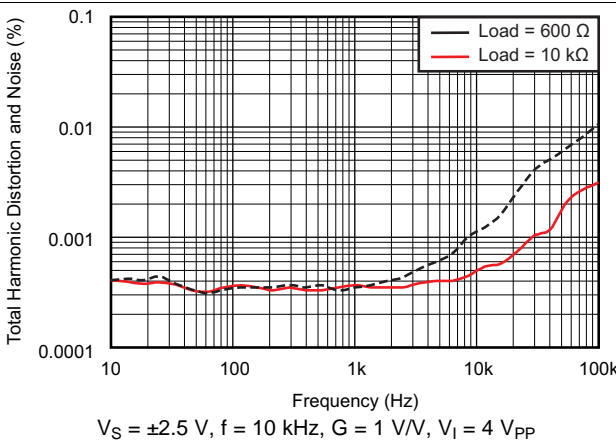

Figure 23. THD+N vs Frequency

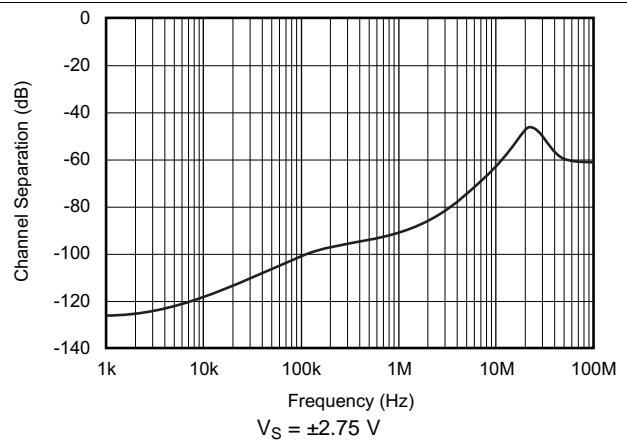
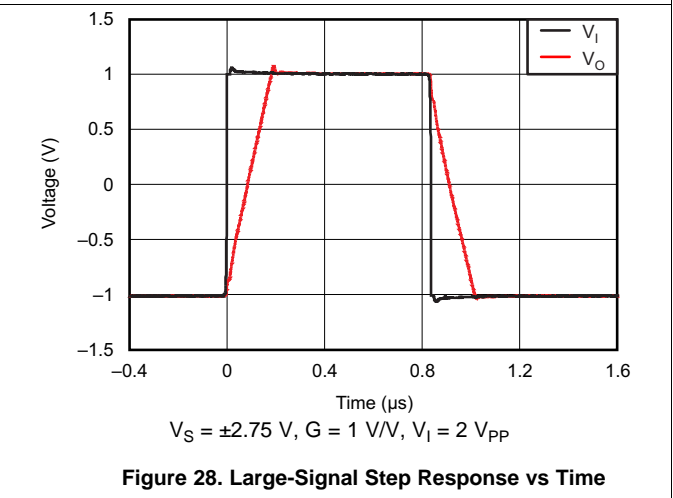
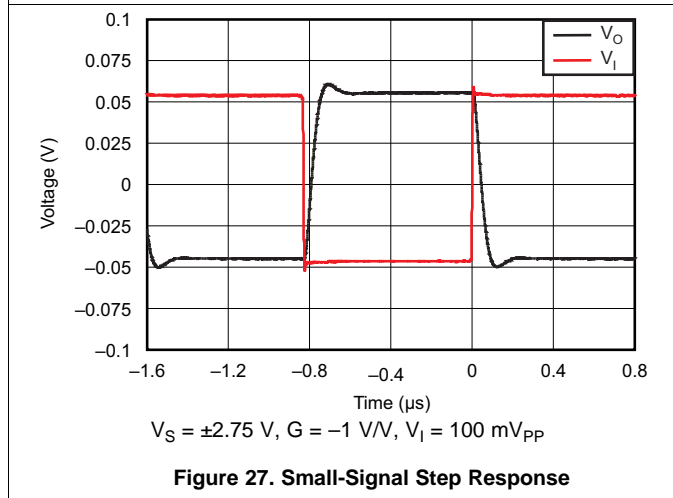
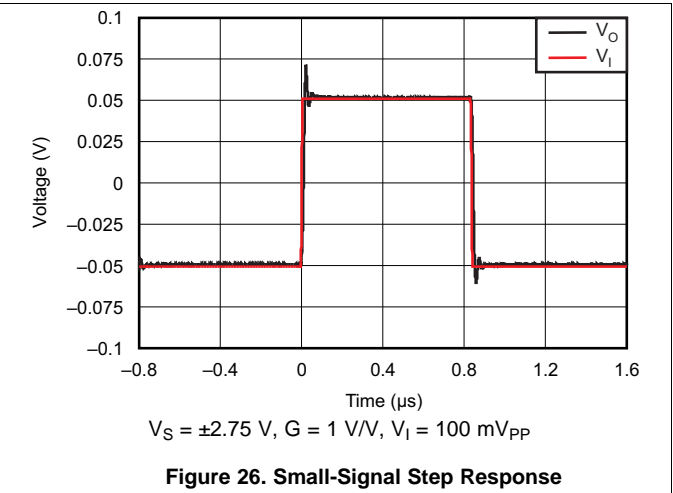
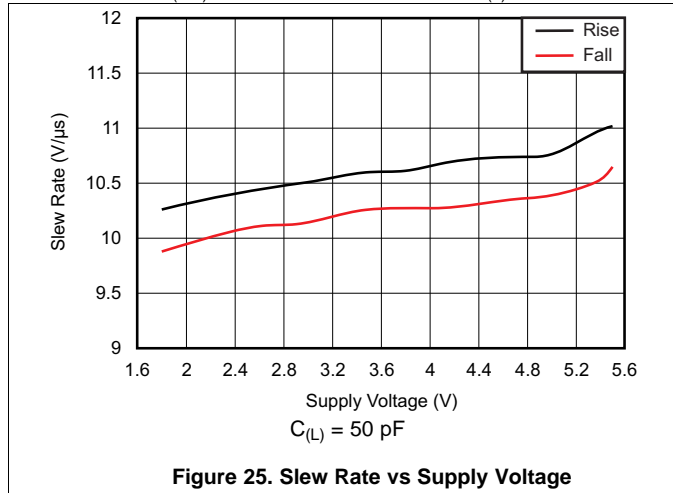

Figure 24. Channel Separation vs Frequency

Typical Characteristics (continued)

at  $T_A = 25^\circ\text{C}$ ,  $V_{(CM)} = V_O = \text{mid-supply}$ , and  $R_{(L)} = 10\text{ k}\Omega$  (unless otherwise noted)



## 7 Detailed Description

### 7.1 Overview

The OPA320-Q1 and OPA2320-Q1 (OPAx320-Q1) operational amplifiers (op amps) are unity-gain stable and operate on a single-supply voltage (1.8 V to 5.5 V), or a split supply voltage ( $\pm 0.9$  V to  $\pm 2.75$  V), making these devices highly versatile and easy to use. The OPAx320-Q1 amplifiers are fully specified from 1.8 V to 5.5 V and over the extended temperature range of  $-40^{\circ}\text{C}$  to  $+125^{\circ}\text{C}$ . Parameters that can exhibit variance with regard to operating voltage or temperature are presented in the [Typical Characteristics](#) section.

### 7.2 Functional Block Diagram

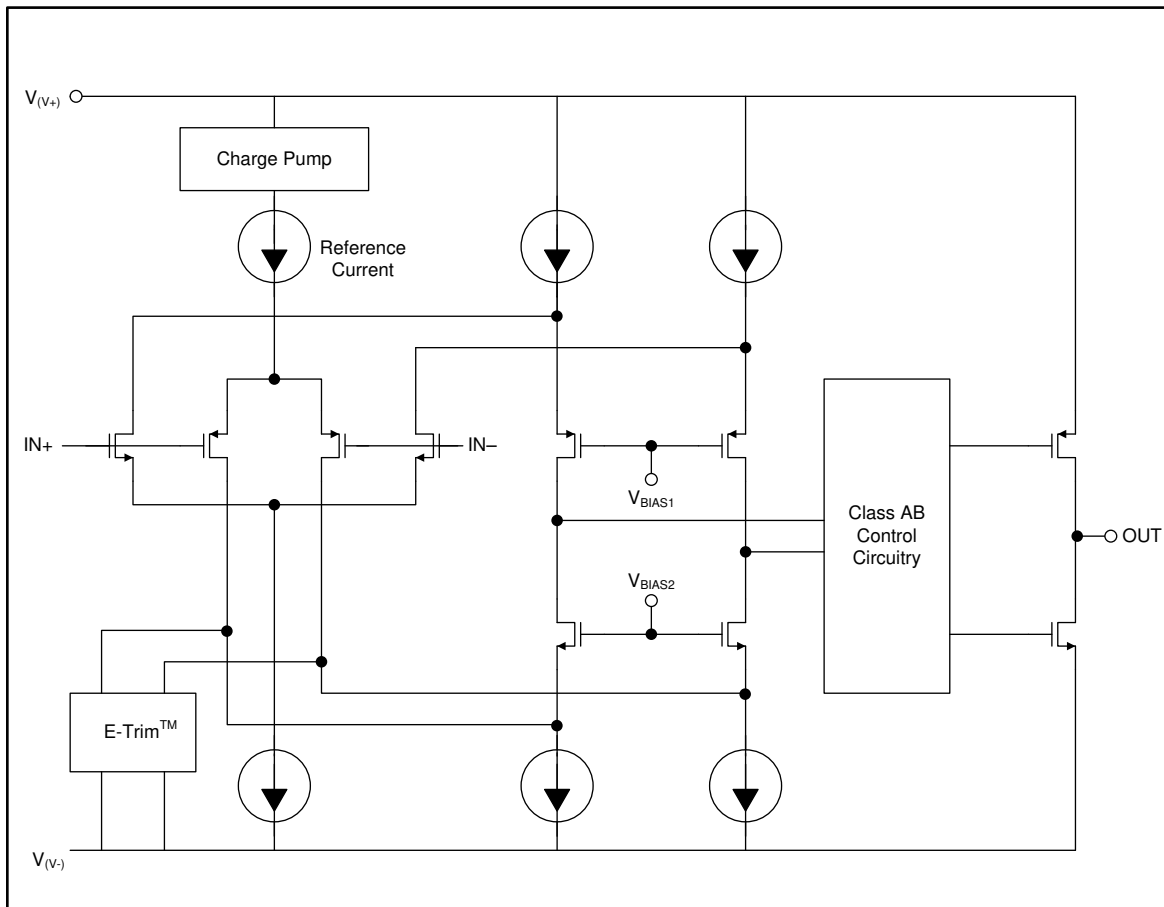

## 7.3 Feature Description

### 7.3.1 Input and ESD Protection

The OPAx320-Q1 incorporate internal electrostatic discharge (ESD) protection circuits on all pins. In the case of input and output pins, this protection primarily consists of current-steering diodes connected between the input and power-supply pins. These ESD protection diodes also provide in-circuit input overdrive protection, provided that the current is limited to 10 mA, as stated in the [Absolute Maximum Ratings](#). Many input signals are inherently current-limited to less than 10 mA; therefore, a limiting resistor is not required. Figure 29 shows how a series input resistor ( $R_{(S)}$ ) may be added to the driven input to limit the input current. The added resistor contributes thermal noise at the amplifier input and the value should be kept to the minimum in noise-sensitive applications.

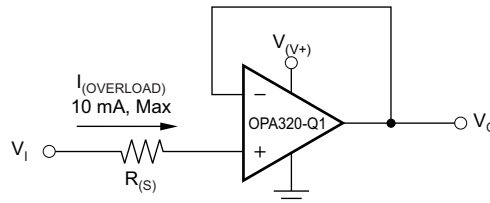
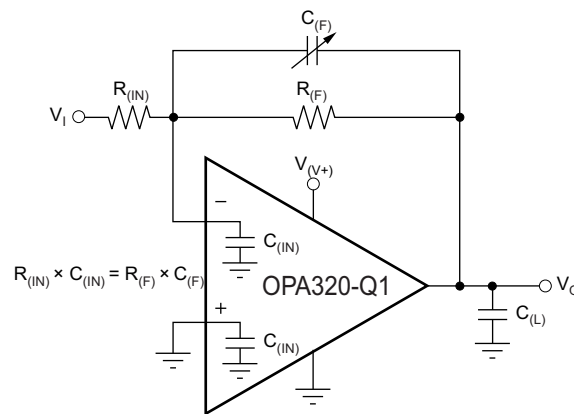

Figure 29. Input Current Protection

### 7.3.2 Feedback Capacitor Improves Response

For optimum settling time and stability with high-impedance feedback networks, adding a feedback capacitor across the feedback resistor,  $R_{(FB)}$ , as shown in Figure 30 may be necessary. This capacitor compensates for the zero created by the feedback network impedance and the OPAx320-Q1 input capacitance (and any parasitic layout capacitance). The effect becomes more significant with higher impedance networks.



NOTE: Where  $C_{(IN)}$  is equal to the OPAx320-Q1 input capacitance (approximately 9 pF) plus any parasitic layout capacitance.

Figure 30. Feedback Capacitor Improves Dynamic Performance

It is suggested that a variable capacitor be used for the feedback capacitor because input capacitance may vary between op amps and layout capacitance is difficult to determine. For the circuit shown in Figure 30, the value of the variable feedback capacitor should be chosen so that the input resistance times the input capacitance of the OPAx320-Q1 (9 pF, typical) plus the estimated parasitic layout capacitance equals the feedback capacitor times the feedback resistor:

$$R_{(IN)} \times C_{(IN)} = R_{(FB)} \times C_{(FB)}$$

Where:

- $C_{(IN)}$  is equal to the OPAx320-Q1 input capacitance (sum of differential and common-mode) plus the layout capacitance. (1)

The capacitor value can be adjusted until optimum performance is obtained.

## Feature Description (continued)

### 7.3.3 EMI Susceptibility And Input Filtering

Operational amplifiers vary in susceptibility to electromagnetic interference (EMI). If conducted EMI enters the operational amplifier, the DC offset observed at the amplifier output may shift from the nominal value while EMI is present. This shift is a result of signal rectification associated with the internal semiconductor junctions. While all operational amplifier pin functions can be affected by EMI, the input pins are likely to be the most susceptible. The OPAx320-Q1 operational amplifier family incorporates an internal input low-pass filter that reduces the amplifiers response to EMI. Both common-mode and differential mode filtering are provided by the input filter. The filter is designed for a cut-off frequency of approximately 580 MHz (–3 dB), with a roll-off of 20 dB per decade.

### 7.3.4 Output Impedance

The open-loop output impedance of the OPAx320-Q1 common-source output stage is approximately 90 Ω. When the op amp is connected with feedback, this value is reduced significantly by the loop gain. For example, with 130 dB (typical) of open-loop gain, the output impedance is reduced in unity-gain to less than 0.03 Ω. For each decade rise in the closed-loop gain, the loop gain is reduced by the same amount, which results in a ten-fold increase in effective output impedance. While the OPAx320-Q1 output impedance remains very flat over a wide frequency range, at higher frequencies the output impedance rises as the open-loop gain of the op amp drops. However, at these frequencies the output also becomes capacitive as a result of parasitic capacitance. This in turn prevents the output impedance from becoming too high, which can cause stability problems when driving large capacitive loads. As mentioned previously, the OPAx320-Q1 have excellent capacitive load drive capability for op amps with the bandwidth.

### 7.3.5 Capacitive Load and Stability

The OPAx320-Q1 are designed to be used in applications where driving a capacitive load is required. As with all op amps, there may be specific instances where the OPAx320-Q1 can become unstable. The particular op amp circuit configuration, layout, gain, and output loading are some of the factors to consider when establishing whether an amplifier is stable in operation. An op amp in the unity-gain (1 V/V) buffer configuration and driving a capacitive load exhibits a greater tendency to become unstable than an amplifier operated at a higher noise gain. The capacitive load, in conjunction with the op amp output resistance, creates a pole within the feedback loop that degrades the phase margin. The degradation of the phase margin increases as the capacitive loading increases. When operating in the unity-gain configuration, the OPAx320-Q1 remain stable with a pure capacitive load up to approximately 1 nF.

The equivalent series resistance (ESR) of some very large capacitors ( $C_{(L)} > 1 \mu\text{F}$ ) is sufficient to alter the phase characteristics in the feedback loop such that the amplifier remains stable. Increasing the amplifier closed-loop gain allows the amplifier to drive increasingly larger capacitance. This increased capability is evident when observing the overshoot response of the amplifier at higher voltage gains; see Figure 32. One technique for increasing the capacitive load drive capability of the amplifier operating in unity gain is to insert a small resistor ( $R_{(S)}$ ), typically 10 Ω to 20 Ω, in series with the output, as shown in Figure 31.

This resistor significantly reduces the overshoot and ringing associated with large capacitive loads. A possible problem with this technique is that a voltage divider is created with the added series resistor and any resistor connected in parallel with the capacitive load. The voltage divider introduces a gain error at the output that reduces the output swing. The error contributed by the voltage divider may be insignificant. For instance, with a load resistance,  $R_{(L)} = 10 \text{ k}\Omega$  and  $R_{(S)} = 20 \Omega$ , the gain error is only about 0.2%. However, when  $R_{(L)}$  is decreased to 600 Ω, which the OPAx320-Q1 are able to drive, the error increases to 7.5%.

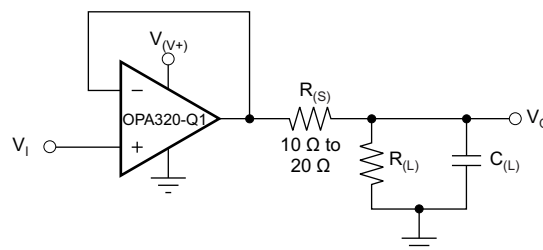

**Figure 31. Improving Capacitive Load Drive**

Feature Description (continued)

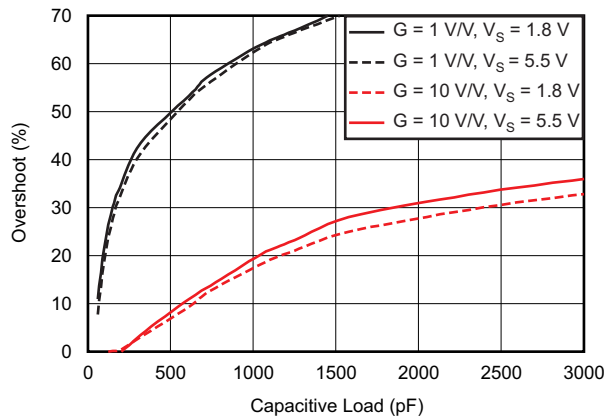
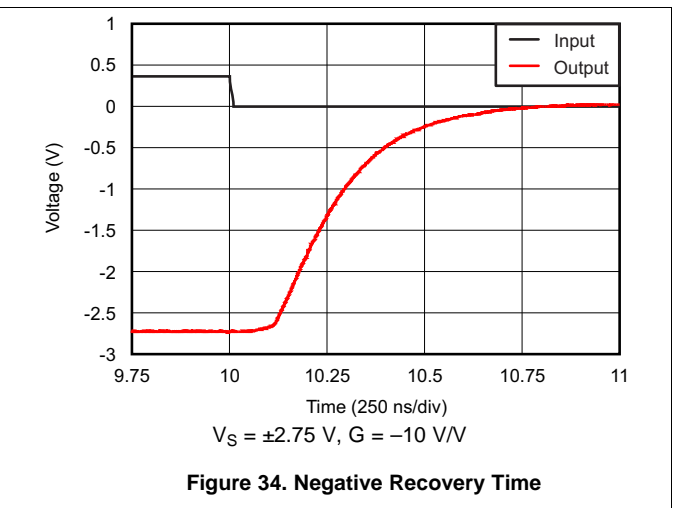
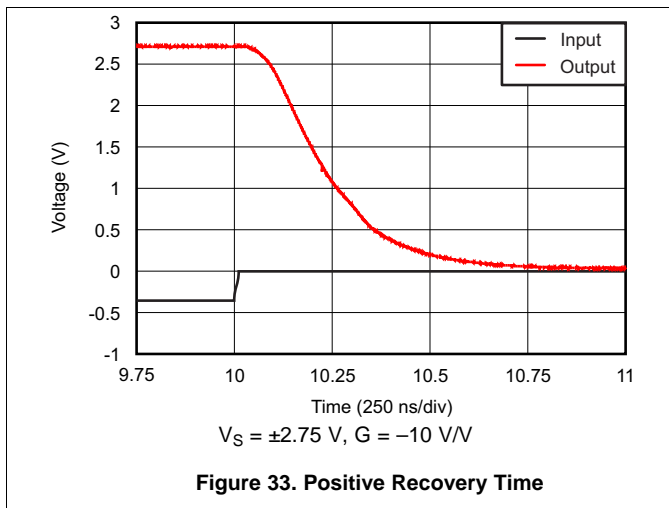

Figure 32. Small-Signal Overshoot versus Capacitive Load (100-mV<sub>pp</sub> Output Step)

7.3.6 Overload Recovery Time

Overload recovery time is the time it takes the output of the amplifier to come out of saturation and recover to the linear region. Overload recovery is particularly important in applications where small signals must be amplified in the presence of large transients. Figure 33 and Figure 34 show the positive and negative overload recovery times of the OPAx320-Q1, respectively. In both cases, the time elapsed before the OPAx320-Q1 come out of saturation is less than 100 ns. In addition, the symmetry between the positive and negative recovery times allows excellent signal rectification without distortion of the output signal.



## 7.4 Device Functional Modes

### 7.4.1 Rail-to-Rail Input

The OPAx320-Q1 feature true rail-to-rail input operation, with supply voltages as low as  $\pm 0.9$  V (1.8 V). The design of the OPAx320-Q1 amplifiers include an internal charge-pump that powers the amplifier input stage with an internal supply rail at approximately 1.6 V above the external supply ( $V_+$ ). This internal supply rail allows the single differential input pair to operate and remain very linear over a very wide input common-mode range. A unique zero-crossover input topology eliminates the input offset transition region typical of many rail-to-rail, complementary input stage operational amplifiers. This topology allows the OPAx320-Q1 to provide superior common-mode performance (CMRR > 110 dB, typical) over the entire common-mode input range, which extends 100 mV beyond both power-supply rails. When driving analog-to-digital converters (ADCs), the highly linear  $V_{(CM)}$  range of the OPAx320-Q1 provides maximum linearity and lowest distortion.

### 7.4.2 Phase Reversal

The OPAx320-Q1 op amps are designed to be immune to phase reversal when the input pins exceed the supply voltages, and thus provide further in-system stability and predictability. Figure 35 shows the input voltage exceeding the supply voltage without any phase reversal.

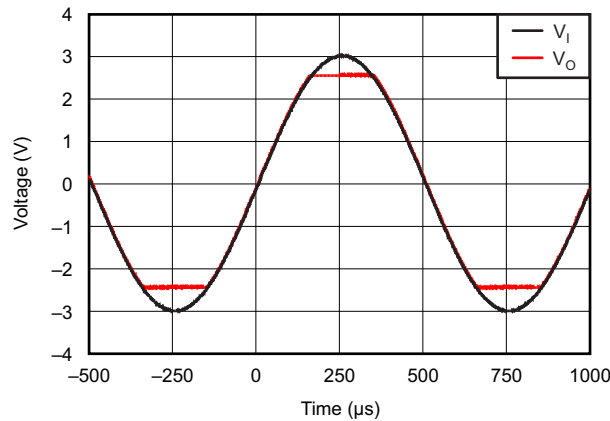

$$V_S = \pm 2.5 \text{ V}$$

Figure 35. No Phase Reversal

## 8 Application and Implementation

### NOTE

Information in the following applications sections is not part of the TI component specification, and TI does not warrant its accuracy or completeness. TI's customers are responsible for determining suitability of components for their purposes. Customers should validate and test their design implementation to confirm system functionality.

### 8.1 Application Information

The OPAx320-Q1 can be used in a wide range of applications, such as transimpedance amplifiers, high-impedance sensors, active filters, and driving ADCs.

### 8.2 Typical Applications

#### 8.2.1 Transimpedance Amplifier

Wide gain bandwidth, low input bias current, low input voltage, and current noise make the OPAx320-Q1 an excellent wideband photodiode transimpedance amplifier. Low-voltage noise is important because photodiode capacitance causes the effective noise gain of the circuit to increase at high frequency.

The key elements to a transimpedance design, as shown in [Figure 36](#), are the expected diode capacitance ( $C_{(D)}$ ), which should include the parasitic input common-mode and differential-mode input capacitance (4 pF + 5 pF); the desired transimpedance gain ( $R_{(FB)}$ ); and the gain-bandwidth (GBW) for the OPAx320-Q1 (20 MHz). With these three variables set, the feedback capacitor value ( $C_{(FB)}$ ) can be set to control the frequency response.  $C_{(FB)}$  includes the stray capacitance of  $R_{(FB)}$ , which is 0.2 pF for a typical surface-mount resistor.

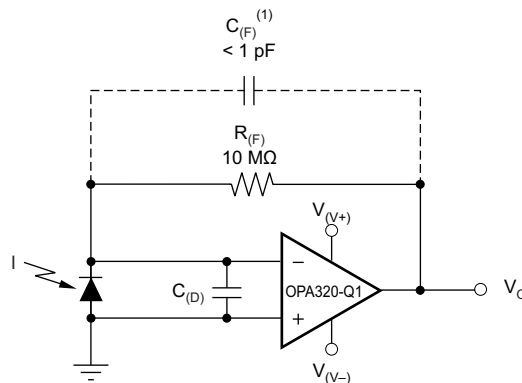

(1)  $C_{(FB)}$  is optional to prevent gain peaking.  $C_{(FB)}$  includes the stray capacitance of  $R_{(FB)}$ .

**Figure 36. Dual-Supply Transimpedance Amplifier**

#### 8.2.1.1 Design Requirements

| PARAMETER                 | VALUE  |
|---------------------------|--------|
| Supply voltage $V_{(V+)}$ | 2.5 V  |
| Supply voltage $V_{(V-)}$ | -2.5 V |

### 8.2.1.2 Detailed Design Procedure

To achieve a maximally-flat, second-order Butterworth frequency response, the feedback pole should be set to:

$$\frac{1}{2 \times \pi \times R_{(FB)} \times C_{(FB)}} = \sqrt{\frac{GBW}{4 \times \pi \times R_{(FB)} \times C_{(D)}}} \quad (2)$$

Use [Equation 3](#) to calculate the bandwidth.

$$f_{(-3 \text{ dB})} = \sqrt{\frac{GBW}{2 \times \pi \times R_{(FB)} \times C_{(D)}}} \quad (3)$$

For even higher transimpedance bandwidth, consider the high-speed CMOS [OPA380](#) (90-MHz GBW), [OPA354](#) (100-MHz GBW), [OPA300](#) (180-MHz GBW), [OPA355](#) (200-MHz GBW), and [OPA656](#) or [OPA657](#) (400-MHz GBW).

For single-supply applications, the +INx input can be biased with a positive dc voltage to allow the output to reach true zero when the photodiode is not exposed to any light, and respond without the added delay that results from coming out of the negative rail; this configuration is shown in [Figure 37](#). This bias voltage also appears across the photodiode, providing a reverse bias for faster operation.

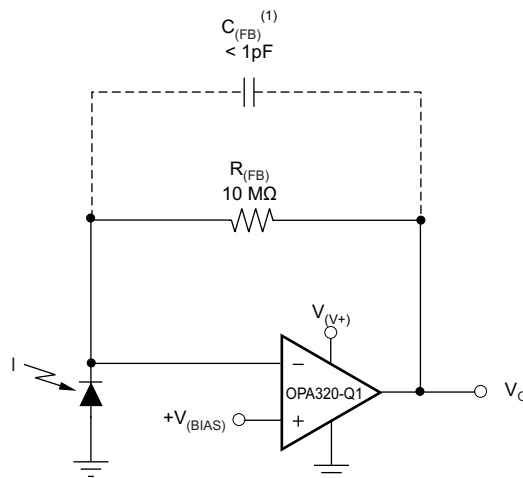

(1)  $C_{(FB)}$  is optional to prevent gain peaking.  $C_{(FB)}$  includes the stray capacitance of  $R_{(FB)}$ .

**Figure 37. Single-Supply Transimpedance Amplifier**

For additional information, refer to the [Compensate Transimpedance Amplifiers Intuitively Application Report](#).

#### 8.2.1.2.1 Optimizing The Transimpedance Circuit

To achieve the best performance, components should be selected according to the following guidelines:

1. For lowest noise, select  $R_{(FB)}$  to create the total required gain. Using a lower value for  $R_{(FB)}$  and adding gain after the transimpedance amplifier generally produces poorer noise performance. The noise produced by  $R_{(FB)}$  increases with the square-root of  $R_{(FB)}$ , whereas the signal increases linearly. Therefore, signal-to-noise ratio improves when all the required gain is placed in the transimpedance stage.
2. Minimize photodiode capacitance and stray capacitance at the summing junction (inverting input). This capacitance causes the voltage noise of the op amp to be amplified (increasing amplification at high frequency). Using a low-noise voltage source to reverse-bias a photodiode can significantly reduce the capacitance. Smaller photodiodes have lower capacitance. Use optics to concentrate light on a small photodiode.
3. Noise increases with increased bandwidth. Limit the circuit bandwidth to only that required. Use a capacitor across the  $R_{(FB)}$  to limit bandwidth, even if not required for stability.

- Circuit board leakage can degrade the performance of an otherwise well-designed amplifier. Clean the circuit board carefully. A circuit board guard trace that encircles the summing junction and is driven at the same voltage can help control leakage.

For additional information, refer to the following documents:

- Texas Instruments, [Noise Analysis of FET Transimpedance Amplifiers Application Bulletin](#)
- Texas Instruments, [Noise Analysis for High-Speed Op Amps Application Report](#)

### 8.2.1.3 Application Curves

Wide gain bandwidth as shown in Figure 38 and low input voltage noise as shown in Figure 39 make the OPAx320-Q1 device an excellent wideband photodiode transimpedance amplifier.

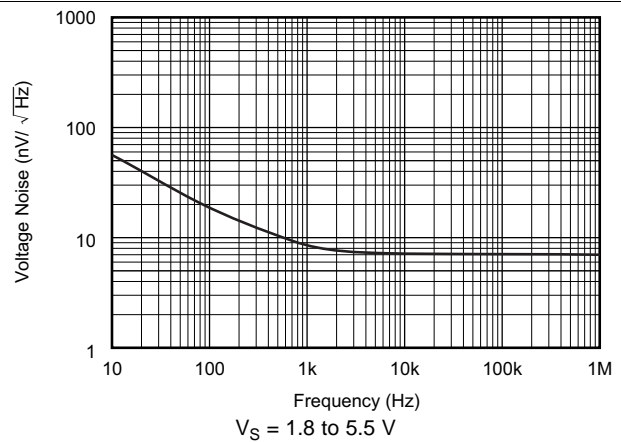
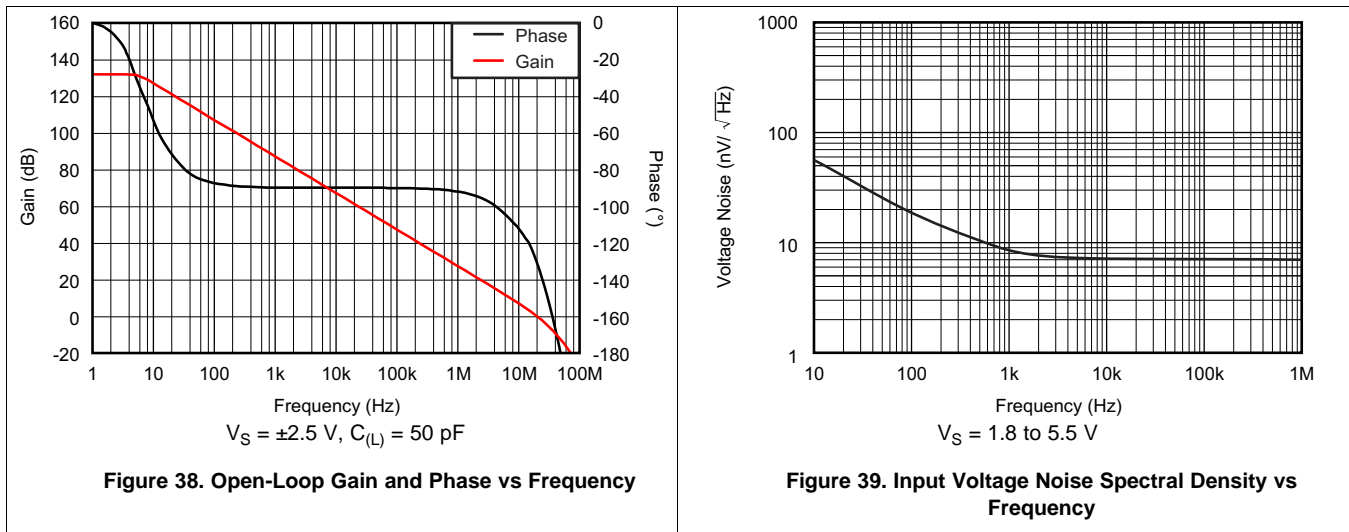

### 8.2.2 High-Impedance Sensor Interface

Many sensors have high source impedances that may range up to 10 MΩ, or even higher. The output signal of sensors often must be amplified or otherwise conditioned by means of an amplifier. The input bias current of this amplifier can load the sensor output and cause a voltage drop across the source resistance, as shown in Figure 40, where  $V_{(+INx)} = V_S - I_{(BIAS)} \times R_{(S)}$ . The last term,  $I_{(BIAS)} \times R_{(S)}$ , shows the voltage drop across  $R_{(S)}$ . To prevent errors introduced to the system as a result of this voltage, an op amp with very low input bias current must be used with high impedance sensors. This low current keeps the error contribution by  $I_{(BIAS)} \times R_{(S)}$  less than the input voltage noise of the amplifier, so that it does not become the dominant noise factor. The OPAx320-Q1 series of op amps feature very low input bias current (typically 200 fA), and are therefore excellent choices for such applications.

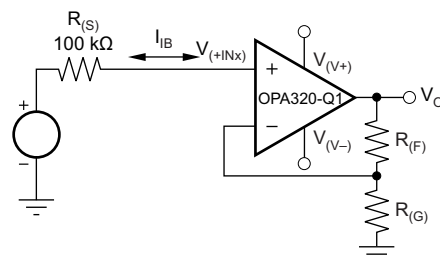

**Figure 40. Noise as a Result of  $I_{(BIAS)}$**

### 8.2.3 Driving ADCs

The OPAx320-Q1 series op amps are an excellent choice for driving sampling analog-to-digital converters (ADCs) with sampling speeds up to 1 MSPS. The zero-crossover distortion input stage topology allows the OPAx320-Q1 to drive ADCs without degradation of differential linearity and THD.

The OPAx320-Q1 can be used to buffer the ADC switched input capacitance and resulting charge injection while providing signal gain. Figure 42 shows the OPAx320-Q1 configured to drive the ADS8326.

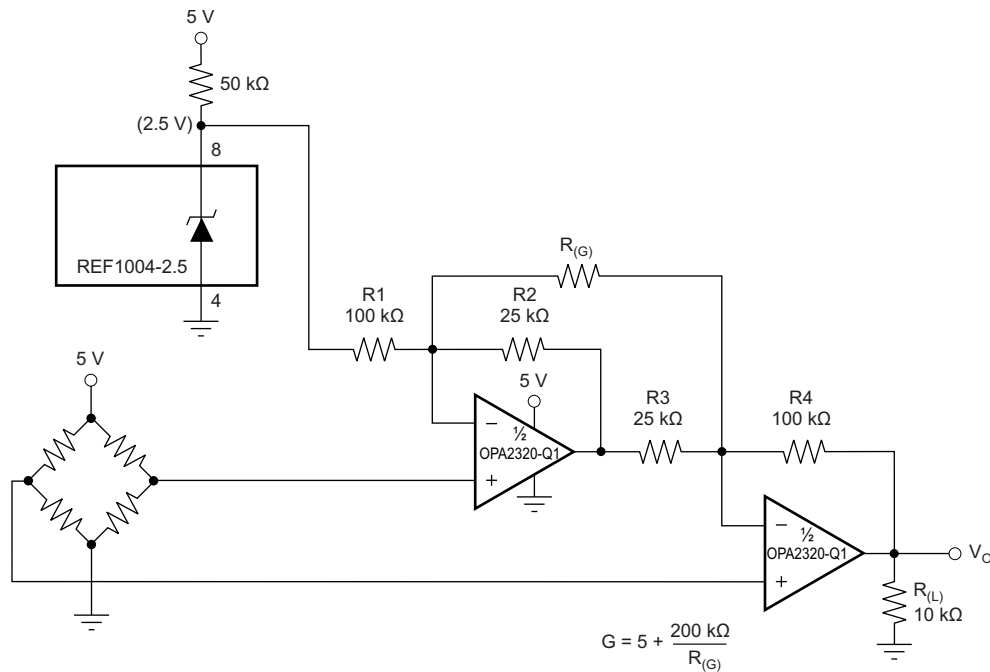
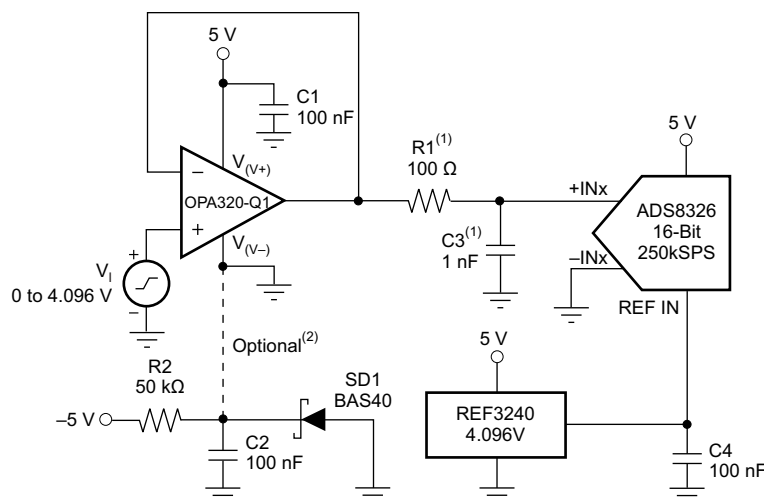

Figure 41. Two Op-Amp Instrumentation Amplifier With Improved High-Frequency Common-Mode Rejection



(1) Suggested value; may require adjustment based on specific application.

(2) Single-supply applications lose a small number of ADC codes near ground as a result of op amp output swing limitation. If a negative power supply is available, this simple circuit creates a -0.3-V supply to allow output swing to true ground potential.

Figure 42. Driving the ADS8326

### 8.2.4 Active Filter

The OPAx320-Q1 is an excellent choice for active filter applications that require a wide bandwidth, fast slew rate, low-noise, single-supply operational amplifier. Figure 43 shows a 500 kHz, second-order, low-pass filter using the multiple-feedback (MFB) topology. The components have been selected to provide a maximally-flat Butterworth response. Beyond the cutoff frequency, roll-off is  $-40$  dB/dec. The Butterworth response is excellent for applications requiring predictable gain characteristics, such as the antialiasing filter used in front of an ADC.

One point to observe when considering the MFB filter is that the output is inverted, relative to the input. If this inversion is not required, or not desired, a noninverting output can be achieved through one of the following options:

1. adding an inverting amplifier
2. adding an additional second-order MFB stage
3. using a noninverting filter topology, such as the Sallen-Key

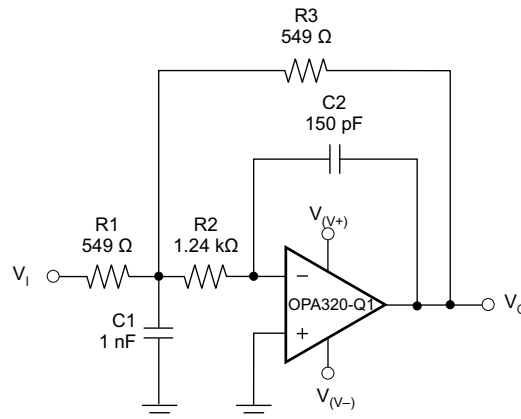

Figure 43. Second-Order Butterworth 500-kHz Low-Pass Filter

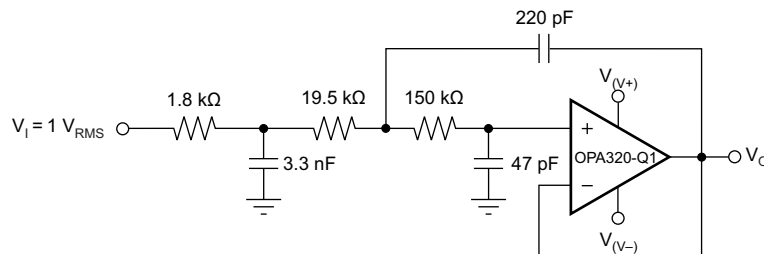

Figure 44. OPAx320-Q1 Configured as a Three-Pole, 20-kHz, Sallen-Key Filter

## 9 Power Supply Recommendations

The OPAx320-Q1 are specified for operation from 1.8 V to 5.5 V ( $\pm 0.9$  V to  $\pm 2.75$  V); many specifications apply from  $-40^{\circ}\text{C}$  to  $+125^{\circ}\text{C}$ . Parameters that can exhibit significant variance with regard to operating voltage or temperature are presented in the [Typical Characteristics](#) section.

### CAUTION

Supply voltages larger than 6 V can permanently damage the device (see the [Absolute Maximum Ratings](#) table).

Place 0.1- $\mu\text{F}$  bypass capacitors close to the power-supply pins to reduce errors coupling in from noisy or high-impedance power supplies. For more detailed information on bypass capacitor placement, see the [Layout Guidelines](#) section.

## 10 Layout

### 10.1 Layout Guidelines

For best operational performance of the device, use good PCB layout practices, including:

- Noise can propagate into analog circuitry through the power pins of the circuit as a whole and operational amplifier itself. Bypass capacitors are used to reduce the coupled noise by providing low-impedance power sources local to the analog circuitry.
  - Connect low-ESR, 0.1- $\mu\text{F}$  ceramic bypass capacitors between each supply pin and ground, placed as close to the device as possible. A single bypass capacitor from V+ to ground is applicable for single-supply applications.
- Separate grounding for analog and digital portions of circuitry is one of the simplest and most-effective methods of noise suppression. One or more layers on multilayer PCBs are usually devoted to ground planes. A ground plane helps distribute heat and reduces EMI noise pickup. Make sure to physically separate digital and analog grounds, paying attention to the flow of the ground current. For more detailed information, refer to the [Circuit Board Layout Techniques Application Report](#).
- To reduce parasitic coupling, run the input traces as far away from the supply or output traces as possible. If it is not possible to keep them separate, it is much better to cross the sensitive trace perpendicular as opposed to in parallel with the noisy trace.
- Place the external components as close to the device as possible. As shown in [Figure 45](#), keeping RF and RG close to the inverting input will minimize parasitic capacitance.
- Keep the length of input traces as short as possible. Always remember that the input traces are the most sensitive part of the circuit.
- Consider a driven, low-impedance guard ring around the critical traces. A guard ring can significantly reduce leakage currents from nearby traces that are at different potentials.

## 10.2 Layout Example

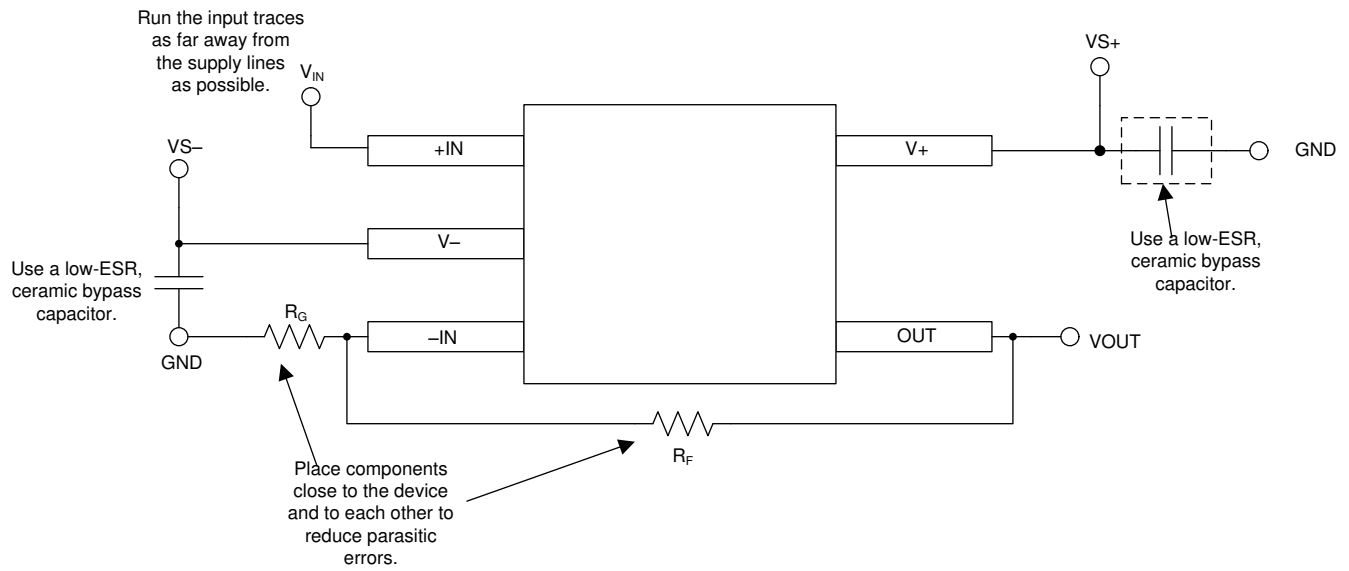

Copyright © 2016, Texas Instruments Incorporated

**Figure 45. Operational Amplifier Board Layout for Noninverting Configuration**

## 11 デバイスおよびドキュメントのサポート

### 11.1 デバイス・サポート

#### 11.1.1 開発サポート

関連資料については、以下を参照してください。

- テキサス・インスツルメンツ、『[ADS8326 16 ビット、高速、2.7V~5.5V microPower サンプルングのアナログ/デジタル・コンバータ](#)』データシート
- テキサス・インスツルメンツ、『[トランスインピーダンス・アンプの直感的な補償](#)』アプリケーション・レポート
- テキサス・インスツルメンツ、『[FET トランスインピーダンス・アンプのノイズ解析](#)』アプリケーション情報
- テキサス・インスツルメンツ、『[高速オペアンプのノイズ解析](#)』アプリケーション・レポート
- テキサス・インスツルメンツ、『[OPAx380 高精度、高速トランスインピーダンス・アンプ](#)』データシート
- テキサス・インスツルメンツ、『[OPAx354 250MHz、レール・ツー・レール I/O、CMOS オペアンプ](#)』データシート
- テキサス・インスツルメンツ、『[OPAx355 200MHz CMOS オペアンプ、シャットダウン付き](#)』データシート
- テキサス・インスツルメンツ、『[OPA656 広帯域、ユニティ・ゲイン安定、FET 入力オペアンプ](#)』データシート

#### 11.2 関連リンク

表 1 に、クイック・アクセス・リンクの一覧を示します。カテゴリには、技術資料、サポートおよびコミュニティ・リソース、ツールとソフトウェア、およびサンプル注文またはご購入へのクイック・アクセスが含まれます。

表 1. 関連リンク

| 製品         | プロダクト・フォルダ              | サンプルとご購入                | 技術資料                    | ツールとソフトウェア              | サポートとコミュニティ             |
|------------|-------------------------|-------------------------|-------------------------|-------------------------|-------------------------|
| OPA320-Q1  | <a href="#">ここをクリック</a> | <a href="#">ここをクリック</a> | <a href="#">ここをクリック</a> | <a href="#">ここをクリック</a> | <a href="#">ここをクリック</a> |
| OPA2320-Q1 | <a href="#">ここをクリック</a> | <a href="#">ここをクリック</a> | <a href="#">ここをクリック</a> | <a href="#">ここをクリック</a> | <a href="#">ここをクリック</a> |

#### 11.3 ドキュメントの更新通知を受け取る方法

ドキュメントの更新についての通知を受け取るには、ti.comのデバイス製品フォルダを開いてください。右上の「アラートを受け取る」をクリックして登録すると、変更されたすべての製品情報に関するダイジェストを毎週受け取れます。変更の詳細については、修正されたドキュメントに含まれている改訂履歴をご覧ください。

#### 11.4 コミュニティ・リソース

The following links connect to TI community resources. Linked contents are provided "AS IS" by the respective contributors. They do not constitute TI specifications and do not necessarily reflect TI's views; see TI's [Terms of Use](#).

**TI E2E™ オンライン・コミュニティ** TIのE2E ( *Engineer-to-Engineer* ) コミュニティ。エンジニア間の共同作業を促進するために開設されたものです。e2e.ti.comでは、他のエンジニアに質問し、知識を共有し、アイデアを検討して、問題解決に役立てることができます。

**設計サポート** TIの設計サポート役に立つE2Eフォーラムや、設計サポート・ツールをすばやく見つけることができます。技術サポート用の連絡先情報も参照できます。

#### 11.5 商標

E2E is a trademark of Texas Instruments.

All other trademarks are the property of their respective owners.

#### 11.6 静電気放電に関する注意事項



すべての集積回路は、適切なESD保護方法を用いて、取扱いと保存を行うようにして下さい。

静電気放電はわずかな性能の低下から完全なデバイスの故障に至るまで、様々な損傷を与えます。高精度の集積回路は、損傷に対して敏感であり、極めてわずかなパラメータの変化により、デバイスに規定された仕様に適合しなくなる場合があります。

## 11.7 Glossary

[SLYZ022](#) — *TI Glossary*.

This glossary lists and explains terms, acronyms, and definitions.

## 12 メカニカル、パッケージ、および注文情報

以降のページには、メカニカル、パッケージ、および注文に関する情報が記載されています。この情報は、そのデバイスについて利用可能な最新のデータです。このデータは予告なく変更されることがあり、ドキュメントが改訂される場合もあります。本データシートのブラウザ版を使用されている場合は、画面左側の説明をご覧ください。

**PACKAGING INFORMATION**

| Orderable part number            | Status<br>(1) | Material type<br>(2) | Package   Pins   | Package qty   Carrier | RoHS<br>(3) | Lead finish/<br>Ball material<br>(4) | MSL rating/<br>Peak reflow<br>(5) | Op temp (°C) | Part marking<br>(6) |
|----------------------------------|---------------|----------------------|------------------|-----------------------|-------------|--------------------------------------|-----------------------------------|--------------|---------------------|
| <a href="#">OPA2320AQDGKRQ1</a>  | Active        | Production           | VSSOP (DGK)   8  | 2500   LARGE T&R      | Yes         | NIPDAU   NIPDAUAG                    | Level-2-260C-1 YEAR               | -40 to 125   | ZAEV                |
| OPA2320AQDGKRQ1.A                | Active        | Production           | VSSOP (DGK)   8  | 2500   LARGE T&R      | Yes         | NIPDAUAG                             | Level-2-260C-1 YEAR               | -40 to 125   | ZAEV                |
| <a href="#">OPA320AQDBVRQ1</a>   | Active        | Production           | SOT-23 (DBV)   5 | 3000   LARGE T&R      | Yes         | NIPDAU   SN                          | Level-2-260C-1 YEAR               | -40 to 125   | 15DD                |
| OPA320AQDBVRQ1.B                 | Active        | Production           | SOT-23 (DBV)   5 | 3000   LARGE T&R      | Yes         | NIPDAU                               | Level-2-260C-1 YEAR               | -40 to 125   | 15DD                |
| <a href="#">OPA320AQDBVRQ1G4</a> | Active        | Production           | SOT-23 (DBV)   5 | 3000   LARGE T&R      | Yes         | NIPDAU                               | Level-2-260C-1 YEAR               | -40 to 125   | 15DD                |
| OPA320AQDBVRQ1G4.B               | Active        | Production           | SOT-23 (DBV)   5 | 3000   LARGE T&R      | Yes         | NIPDAU                               | Level-2-260C-1 YEAR               | -40 to 125   | 15DD                |
| <a href="#">OPA320AQDBVTQ1</a>   | Active        | Production           | SOT-23 (DBV)   5 | 250   SMALL T&R       | Yes         | NIPDAU   SN                          | Level-2-260C-1 YEAR               | -40 to 125   | 15DD                |
| OPA320AQDBVTQ1.B                 | Active        | Production           | SOT-23 (DBV)   5 | 250   SMALL T&R       | Yes         | NIPDAU                               | Level-2-260C-1 YEAR               | -40 to 125   | 15DD                |

(1) **Status:** For more details on status, see our [product life cycle](#).

(2) **Material type:** When designated, preproduction parts are prototypes/experimental devices, and are not yet approved or released for full production. Testing and final process, including without limitation quality assurance, reliability performance testing, and/or process qualification, may not yet be complete, and this item is subject to further changes or possible discontinuation. If available for ordering, purchases will be subject to an additional waiver at checkout, and are intended for early internal evaluation purposes only. These items are sold without warranties of any kind.

(3) **RoHS values:** Yes, No, RoHS Exempt. See the [TI RoHS Statement](#) for additional information and value definition.

(4) **Lead finish/Ball material:** Parts may have multiple material finish options. Finish options are separated by a vertical ruled line. Lead finish/Ball material values may wrap to two lines if the finish value exceeds the maximum column width.

(5) **MSL rating/Peak reflow:** The moisture sensitivity level ratings and peak solder (reflow) temperatures. In the event that a part has multiple moisture sensitivity ratings, only the lowest level per JEDEC standards is shown. Refer to the shipping label for the actual reflow temperature that will be used to mount the part to the printed circuit board.

(6) **Part marking:** There may be an additional marking, which relates to the logo, the lot trace code information, or the environmental category of the part.

Multiple part markings will be inside parentheses. Only one part marking contained in parentheses and separated by a "-" will appear on a part. If a line is indented then it is a continuation of the previous line and the two combined represent the entire part marking for that device.

**Important Information and Disclaimer:** The information provided on this page represents TI's knowledge and belief as of the date that it is provided. TI bases its knowledge and belief on information provided by third parties, and makes no representation or warranty as to the accuracy of such information. Efforts are underway to better integrate information from third parties. TI has taken and continues to take reasonable steps to provide representative and accurate information but may not have conducted destructive testing or chemical analysis on incoming materials and chemicals. TI and TI suppliers consider certain information to be proprietary, and thus CAS numbers and other limited information may not be available for release.

In no event shall TI's liability arising out of such information exceed the total purchase price of the TI part(s) at issue in this document sold by TI to Customer on an annual basis.

**OTHER QUALIFIED VERSIONS OF OPA2320-Q1, OPA320-Q1 :**

- Catalog : [OPA2320](#), [OPA320](#)

NOTE: Qualified Version Definitions:

- Catalog - TI's standard catalog product

**TAPE AND REEL INFORMATION**

**QUADRANT ASSIGNMENTS FOR PIN 1 ORIENTATION IN TAPE**

\*All dimensions are nominal

| Device           | Package Type | Package Drawing | Pins | SPQ  | Reel Diameter (mm) | Reel Width W1 (mm) | A0 (mm) | B0 (mm) | K0 (mm) | P1 (mm) | W (mm) | Pin1 Quadrant |
|------------------|--------------|-----------------|------|------|--------------------|--------------------|---------|---------|---------|---------|--------|---------------|
| OPA2320AQDGKRQ1  | VSSOP        | DGK             | 8    | 2500 | 330.0              | 12.4               | 5.3     | 3.4     | 1.4     | 8.0     | 12.0   | Q1            |
| OPA320AQDBVRQ1   | SOT-23       | DBV             | 5    | 3000 | 180.0              | 8.4                | 3.2     | 3.2     | 1.4     | 4.0     | 8.0    | Q3            |
| OPA320AQDBVRQ1   | SOT-23       | DBV             | 5    | 3000 | 178.0              | 9.0                | 3.3     | 3.2     | 1.4     | 4.0     | 8.0    | Q3            |
| OPA320AQDBVRQ1G4 | SOT-23       | DBV             | 5    | 3000 | 178.0              | 9.0                | 3.3     | 3.2     | 1.4     | 4.0     | 8.0    | Q3            |
| OPA320AQDBVTQ1   | SOT-23       | DBV             | 5    | 250  | 180.0              | 8.4                | 3.2     | 3.2     | 1.4     | 4.0     | 8.0    | Q3            |
| OPA320AQDBVTQ1   | SOT-23       | DBV             | 5    | 250  | 178.0              | 9.0                | 3.23    | 3.17    | 1.37    | 4.0     | 8.0    | Q3            |

**TAPE AND REEL BOX DIMENSIONS**

\*All dimensions are nominal

| Device           | Package Type | Package Drawing | Pins | SPQ  | Length (mm) | Width (mm) | Height (mm) |
|------------------|--------------|-----------------|------|------|-------------|------------|-------------|
| OPA2320AQDGKRQ1  | VSSOP        | DGK             | 8    | 2500 | 366.0       | 364.0      | 50.0        |
| OPA320AQDBVRQ1   | SOT-23       | DBV             | 5    | 3000 | 210.0       | 185.0      | 35.0        |
| OPA320AQDBVRQ1   | SOT-23       | DBV             | 5    | 3000 | 180.0       | 180.0      | 18.0        |
| OPA320AQDBVRQ1G4 | SOT-23       | DBV             | 5    | 3000 | 180.0       | 180.0      | 18.0        |
| OPA320AQDBVTQ1   | SOT-23       | DBV             | 5    | 250  | 210.0       | 185.0      | 35.0        |
| OPA320AQDBVTQ1   | SOT-23       | DBV             | 5    | 250  | 180.0       | 180.0      | 18.0        |



# EXAMPLE BOARD LAYOUT

DBV0005A

SOT-23 - 1.45 mm max height

SMALL OUTLINE TRANSISTOR



LAND PATTERN EXAMPLE  
EXPOSED METAL SHOWN  
SCALE:15X



SOLDER MASK DETAILS

4214839/K 08/2024

NOTES: (continued)

- 6. Publication IPC-7351 may have alternate designs.
- 7. Solder mask tolerances between and around signal pads can vary based on board fabrication site.

# EXAMPLE STENCIL DESIGN

DBV0005A

SOT-23 - 1.45 mm max height

SMALL OUTLINE TRANSISTOR



SOLDER PASTE EXAMPLE  
BASED ON 0.125 mm THICK STENCIL  
SCALE:15X

4214839/K 08/2024

NOTES: (continued)

8. Laser cutting apertures with trapezoidal walls and rounded corners may offer better paste release. IPC-7525 may have alternate design recommendations.
9. Board assembly site may have different recommendations for stencil design.

DGK0008A



PACKAGE OUTLINE

VSSOP - 1.1 mm max height

SMALL OUTLINE PACKAGE



4214862/A 04/2023

NOTES:

PowerPAD is a trademark of Texas Instruments.

1. All linear dimensions are in millimeters. Any dimensions in parenthesis are for reference only. Dimensioning and tolerancing per ASME Y14.5M.
2. This drawing is subject to change without notice.
3. This dimension does not include mold flash, protrusions, or gate burrs. Mold flash, protrusions, or gate burrs shall not exceed 0.15 mm per side.
4. This dimension does not include interlead flash. Interlead flash shall not exceed 0.25 mm per side.
5. Reference JEDEC registration MO-187.

# EXAMPLE BOARD LAYOUT

DGK0008A

<sup>TM</sup> VSSOP - 1.1 mm max height

SMALL OUTLINE PACKAGE



LAND PATTERN EXAMPLE  
EXPOSED METAL SHOWN  
SCALE: 15X



SOLDER MASK DETAILS

4214862/A 04/2023

NOTES: (continued)

6. Publication IPC-7351 may have alternate designs.
7. Solder mask tolerances between and around signal pads can vary based on board fabrication site.
8. Vias are optional depending on application, refer to device data sheet. If any vias are implemented, refer to their locations shown on this view. It is recommended that vias under paste be filled, plugged or tented.
9. Size of metal pad may vary due to creepage requirement.

# EXAMPLE STENCIL DESIGN

DGK0008A

<sup>TM</sup> VSSOP - 1.1 mm max height

SMALL OUTLINE PACKAGE



SOLDER PASTE EXAMPLE  
SCALE: 15X

4214862/A 04/2023

NOTES: (continued)

11. Laser cutting apertures with trapezoidal walls and rounded corners may offer better paste release. IPC-7525 may have alternate design recommendations.
12. Board assembly site may have different recommendations for stencil design.

## 重要なお知らせと免責事項

TI は、技術データと信頼性データ (データシートを含みます)、設計リソース (リファレンス デザインを含みます)、アプリケーションや設計に関する各種アドバイス、Web ツール、安全性情報、その他のリソースを、欠陥が存在する可能性のある「現状のまま」提供しており、商品性および特定目的に対する適合性の黙示保証、第三者の知的財産権の非侵害保証を含むいかなる保証も、明示的または黙示的にかかわらず拒否します。

これらのリソースは、TI 製品を使用する設計の経験を積んだ開発者への提供を意図したものです。(1) お客様のアプリケーションに適した TI 製品の選定、(2) お客様のアプリケーションの設計、検証、試験、(3) お客様のアプリケーションに該当する各種規格や、その他のあらゆる安全性、セキュリティ、規制、または他の要件への確実な適合に関する責任を、お客様のみが単独で負うものとし、

上記の各種リソースは、予告なく変更される可能性があります。これらのリソースは、リソースで説明されている TI 製品を使用するアプリケーションの開発の目的でのみ、TI はその使用をお客様に許諾します。これらのリソースに関して、他の目的で複製することや掲載することは禁止されています。TI や第三者の知的財産権のライセンスが付与されている訳ではありません。お客様は、これらのリソースを自身で使用した結果発生するあらゆる申し立て、損害、費用、損失、責任について、TI およびその代理人を完全に補償するものとし、TI は一切の責任を拒否します。

TI の製品は、[TI の販売条件](#)、[TI の総合的な品質ガイドライン](#)、[ti.com](#) または TI 製品などに関連して提供される他の適用条件に従い提供されます。TI がこれらのリソースを提供することは、適用される TI の保証または他の保証の放棄の拡大や変更を意味するものではありません。TI がカスタム、またはカスタマー仕様として明示的に指定していない限り、TI の製品は標準的なカタログに掲載される汎用機器です。

お客様がいかなる追加条項または代替条項を提案する場合も、TI はそれらに異議を唱え、拒否します。

Copyright © 2026, Texas Instruments Incorporated

最終更新日 : 2025 年 10 月