

OPT4001 高速、高精度、デジタル周辺光センサ (ALS)

1 特長

- High speed I²C インターフェイスを使用した高精度の高速光 / デジタル変換を 2 つのパッケージ・バリエーションで提供
- 優れた近赤外線 (IR) 除去機能により人間の目によく合致した高精度の光フィルタリングを実現
- 9 つのバイナリ対数フルスケール光レンジを備えた片対数出力、各レンジ内における非常に線形的な応答
- 内蔵の自動フルスケール光レンジ選択ロジックにより、入力光条件に基づいて測定レンジを切り替え、レンジ間での優れたゲイン・マッチングを実現
- 28 ビットでの実効ダイナミック・レンジ:
 - PicoStar™ パッケージ・バリエーションで 312.5μlux ~ 83klux
 - SOT-5x3 パッケージ・バリエーションで 437.5μlux ~ 117klux
- 変換時間は 600μs から 800ms まで 12 種類を設定可能で、さまざまな高速および高精度アプリケーションに最適
- ハードウェア同期トリガおよび割り込み用の外部ピン割り込み (SOT-5X3 パッケージ・バリエーションのみ)
- I²C バースト読み出し可能な出力レジスタ用内部 FIFO
- 小さい動作電流: 30μA、超低消費電力スタンバイ時: 2μA
- 動作温度範囲: -40°C ~ +85°C
- 広い電源電圧範囲: 1.6V ~ 3.6V
- 5.5V 許容の I/O ピン
- I²C アドレスを選択可能
- 小さいフォームファクタ
 - PicoStar™ パッケージ: 0.84mm x 1.05mm x 0.226mm
 - SOT-5X3: 2.1mm x 1.9mm x 0.6mm

2 アプリケーション

- 下記製品のディスプレイのバックライト制御
 - スマートウォッチ、ウェアラブル・エレクトロニクス、ヘルス・フィットネス・バンド
 - タブレットおよびノートブック PC
 - 多機能プリンタ
 - ホーム・オートメーション・インターフェイス
 - サーモスタットおよびホーム・オートメーション機器
- 照明制御システムによる光のレベル (日中または夜間) の検出
- POS 端末
- 屋外の交通信号機および街路灯
- IP ネットワーク・カメラ
- 光源のフリッカー・レート検出

3 概要

OPT4001 は、可視光の強度を測定する光 / デジタル・センサ (シングルチップのルクス・メーター) です。このセンサのスペクトル応答は、人間の目の明所視応答によく合致しています。本デバイスは特別に設計されたフィルタにより、一般的な光源から近赤外線成分を除去し、正確な光の強度を測定します。OPT4001 の出力は、9 つのバイナリ対数フルスケール光レンジを持つ片対数であり、各レンジ内で非常に線形的な応答を実現しています。その結果、PicoStar™ バリエーションで 312.5μlux ~ 83klux、SOT-5X3 バリエーションで 437.5μlux ~ 117klux を測定できます。この機能により、この光センサは、28 ビットの実効ダイナミック・レンジにわたって測定が可能です。自動フルスケール・レンジ選択ロジックが組み込まれているため、ユーザーは光のレベルごとに適切なゲイン設定を選択する必要がありません。

デバイス情報

部品番号	パッケージ ⁽¹⁾	本体サイズ (公称)
OPT4001	PicoStar™ (4)	0.84mm x 1.05mm x 0.226mm
	SOT-5X3 (8)	1.9mm x 2.1mm x 0.6mm

- (1) 利用可能なパッケージについては、データシートの末尾にあるパッケージ・オプションについての付録を参照してください。

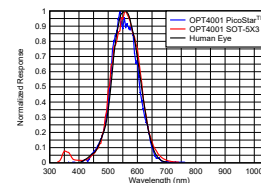

スペクトル応答 : OPT4001 と人間の目の比較

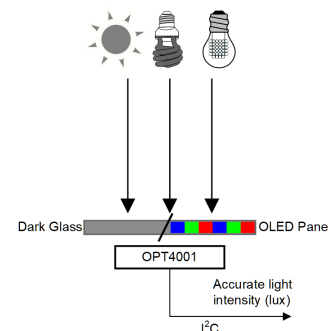

OPT4001 の代表的なアプリケーション図



Table of Contents

1 特長	1	8.5 Programming.....	20
2 アプリケーション	1	8.6 Register Maps.....	26
3 概要	1	9 Application and Implementation	35
4 Revision History	2	9.1 Application Information.....	35
5 概要 (続き)	3	9.2 Typical Application.....	35
6 Pin Configuration and Functions	4	9.3 Do's and Don'ts.....	39
7 Specifications	5	9.4 Power Supply Recommendations.....	39
7.1 Absolute Maximum Ratings.....	5	9.5 Layout.....	39
7.2 ESD Ratings.....	5	10 Device and Documentation Support	45
7.3 Recommended Operating Conditions.....	5	10.1 Documentation Support.....	45
7.4 Thermal Information.....	5	10.2 ドキュメントの更新通知を受け取る方法.....	45
7.5 Electrical Characteristics.....	6	10.3 サポート・リソース.....	45
7.6 Typical Characteristics.....	8	10.4 Trademarks.....	45
8 Detailed Description	11	10.5 静電気放電に関する注意事項.....	45
8.1 Overview.....	11	10.6 用語集.....	45
8.2 Functional Block Diagram.....	11	11 Mechanical, Packaging, and Orderable Information	45
8.3 Feature Description.....	12		
8.4 Device Functional Modes.....	13		

4 Revision History

資料番号末尾の英字は改訂を表しています。その改訂履歴は英語版に準じています。

Changes from Revision * (August 2019) to Revision A (January 2022)	Page
• デバイス SOT-5X3 の新しいパッケージ・バリエーションを追加.....	1
• Added セクション 8.4.2 for package variants.....	15
• Changed values for 表 8-3	17
• Added and changed register names for both package variants.....	26

5 概要 (続き)

OPT4001 の工学的光学フィルタには近赤外線除去機能があるため、産業用の製品設計で美観上の理由からよくある要件として、暗色のガラス下にセンサを設置する場合でも、高い精度を維持できます。

OPT4001 は、ユーザーの使いやすさ向上のために光レベル検出機能を必要とするシステム向けに設計されており、人間の目との一致度が低く近赤外線除去機能が劣る低精度のフォトダイオード、フォトレジスタ、その他の周辺光センサの代替品として利用できます。

OPT4001 デバイスは、12 ステップで 600 μ s から 800ms までの光変換時間で動作するように設定でき、アプリケーションのニーズに応じたシステムの柔軟性を実現します。変換時間には、光の積分時間と ADC 変換時間が含まれます。測定の分解能は光の強度と積分時間の組み合わせによって決まります。Picostar™ バリエントでは実質的に 312.5 μ lux、SOT-5X3 バリエントでは 437.5 μ lux までの光の強度変化を測定できます。

柔軟なデジタル動作により、システムの統合が可能です。測定は連続的に行うことも、レジスタへの書き込みまたはハードウェア・ピン (SOT-5X3 バリエントのみ) を使用して 1 回の測定をトリガすることもできます。このデバイスにはスレッシュホールド検出ロジックが搭載されており、プロセッサはスリープ状態でセンサが適切なウェークアップ・イベントを監視し、当該イベントの発生は割り込みピンで通知されます (SOT-5X3 バリエントのみ)。

光のレベルを表すデジタル出力は、I²C および SMBus 互換の 2 線式シリアル・インターフェイスで通知されます。出力レジスタの内部 FIFO を使用すると、センサからの測定値を低速で読み出すと同時に、デバイスでキャプチャされたすべてのデータを保持できます。また、OPT4001 は I²C バースト・モードもサポートしており、ホストは最小限の I²C オーバーヘッドで FIFO からデータを読み取ることができます。

OPT4001 は、低い消費電力と低い電源電圧で動作するので、バッテリー駆動システムのバッテリー動作時間を延長できます。

6 Pin Configuration and Functions



图 6-1. YMN (PicoStar™) Package, 4-Pin, Top View

表 6-1. Pin Functions

PIN		TYPE	DESCRIPTION
NO.	NAME		
A1	GND	Power	Ground
B1	VDD	Power	Device power. Connect to a 1.6-V to 3.6-V supply.
A2	SCL	Digital input	I ² C clock. Connect with a 10-kΩ resistor to a 1.6-V to 5.5-V supply.
B2	SDA	Digital input/output	I ² C data. Connect with a 10-kΩ resistor to a 1.6-V to 5.5-V supply.

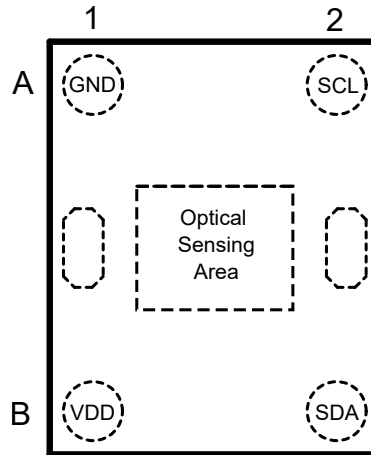

图 6-2. DTS Package, 6-Pin USON, Top View

表 6-2. Pin Functions

PIN		TYPE	DESCRIPTION
NO.	NAME		
1	VDD	Power	Device power. Connect to a 1.6-V to 3.6-V supply.
2	ADDR	Digital input	Address pin. This pin sets the LSBs of the I ² C address.
3	NC	No Connection	No Connection
4	GND	Power	Ground
5	SCL	Digital input	I ² C clock. Connect with a 10-kΩ resistor to a 1.6-V to 5.5-V supply.
6	NC	No Connection	No Connection
7	INT	Digital I/O	Interrupt input/output open-drain. Connect with a 10-kΩ resistor to a 1.6-V to 5.5-V supply.
8	SDA	Digital I/O	I ² C data. Connect with a 10-kΩ resistor to a 1.6-V to 5.5-V supply.

7 Specifications

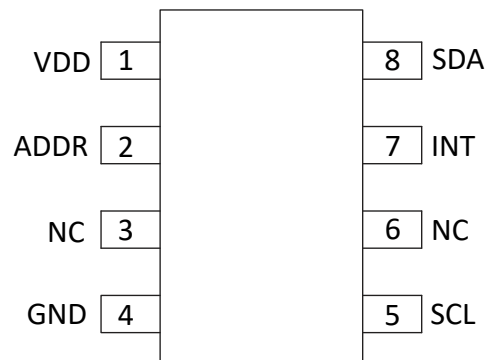
7.1 Absolute Maximum Ratings

over operating free-air temperature range (unless otherwise noted)⁽¹⁾

		MIN	MAX	UNIT
Voltage	VDD to GND	-0.5	6	V
	SDA and SCL to GND	-0.5	6	V
Current in to any pin			10	mA
T _J	Junction temperature		150	°C
T _{stg}	Storage temperature	-65	150 ⁽²⁾	°C

- (1) Operation outside the Absolute Maximum Ratings may cause permanent device damage. Absolute Maximum Ratings do not imply functional operation of the device at these or any other conditions beyond those listed under Recommended Operating Conditions. If used outside the Recommended Operating Conditions but within the Absolute Maximum Ratings, the device may not be fully functional, and this may affect device reliability, functionality, performance, and shorten the device lifetime.
- (2) Long exposure to temperatures higher than 105°C can cause package discoloration, spectral distortion, and measurement inaccuracy.

7.2 ESD Ratings

			VALUE	UNIT
V _(ESD)	Electrostatic discharge	Human body model (HBM), per ANSI/ESDA/ JEDEC JS-001, all pins ⁽¹⁾	±2000	V
		Charged device model (CDM), per ANSI/ESDA/ JEDEC JS-002, all pins ⁽²⁾	±500	

- (1) JEDEC document JEP155 states that 500-V HBM allows safe manufacturing with a standard ESD control process precautions.
- (2) JEDEC document JEP157 states that 250-V CDM allows safe manufacturing with a standard ESD control process.

7.3 Recommended Operating Conditions

over operating free-air temperature range (unless otherwise noted)

		MIN	NOM	MAX	UNIT
VDD	Supply voltage	1.6		3.6	V
T _J	Junction temperature	-40		85	°C

7.4 Thermal Information

THERMAL METRIC ⁽¹⁾		OPT4001		UNIT
		PicoStar™ (YMN)	SOT-5X3 (DTS)	
		4 Pins	8 Pins	
R _{θJA}	Junction-to-ambient thermal resistance	122.8	112.2	°C/W
R _{θJC(top)}	Junction-to-case (top) thermal resistance	1.4	28.4	°C/W
R _{θJB}	Junction-to-board thermal resistance	34.9	22.1	°C/W
Ψ _{JT}	Junction-to-top characterization parameter	0.8	1.2	°C/W
Ψ _{JB}	Junction-to-board characterization parameter	35.3	22	°C/W

- (1) For more information about traditional and new thermal metrics, see the [Semiconductor and IC Package Thermal Metrics](#) application report.

7.5 Electrical Characteristics

All specifications at TA = 25°C, VDD = 3.3 V, 800-ms conversion-time (CONVERSION_TIME=0xB), automatic full-scale range, white LED and normal-angle incidence of light, unless otherwise specified.

PARAMETER		TEST CONDITIONS	MIN	TYP	MAX	UNIT
OPTICAL						
PicoStar™ Variant						
E _{VLSB}	Resolution	Lowest auto gain range, 800 ms conversion-time		312.5		μlux
E _{VLSB}		Lowest auto gain range, 100 ms conversion-time		2.5		mlux
E _{VFS}	Full-scale illuminance			83886		lux
	Angular response (FWHM)			96		°
	Drift across temperature	Visible Light, Input illuminance = 2000 lux		0.01		%/°C
	Linearity	Input illuminance > 328 lux 100 ms conversion-time CONVERSION_TIME=0x8		2		%
		Input illuminance < 328 lux 100 ms conversion-time CONVERSION_TIME=0x8		5		%
SOT-5X3 Variant						
E _{VLSB}	Resolution	Lowest auto gain range, 800 ms conversion-time		437.5		μlux
E _{VLSB}		Lowest auto gain range, 100 ms conversion-time		3.5		mlux
E _{VFS}	Full-scale illuminance			117441		lux
	Angular response (FWHM)			120		°
	Drift across temperature	Visible Light, Input illuminance = 2000 lux		0.015		%/°C
	Linearity	Input illuminance > 459 lux 100 ms conversion-time CONVERSION_TIME=0x8		2		%
		Input illuminance < 459 lux 100 ms conversion-time CONVERSION_TIME=0x8		5		%
Common Specifications						
	Peak irradiance spectral responsivity			550		nm
	Effective MANTISSA bits (Register R_MSB & R_LSB)	Dependent on Conversion Time selected (Register CONVERSION_TIME)	9		20	bits
	Exponent bits (Register E)	Denotes the full-scale range		4		bits
E _V	Measurement output result	2000 lux input ⁽¹⁾	1800	2000	2200	lux
T _{conv}	Light Conversion-time ⁽⁴⁾	Minimum Selectable (CONVERSION_TIME=0x0), fixed lux range, 2000 lux input		600		μs
		Maximum Selectable (CONVERSION_TIME=0xB), fixed lux range, 2000 lux input		800		ms
	Light source variation (incandescent, halogen, fluorescent)	Bare device, no cover glass		4		%
E _{VIR}	Infrared response	850nm Near Infrared		0.2		%
	Relative accuracy between gain ranges ⁽²⁾			0.4		%
	Dark Measurement			0	10	mlux
PSRR	Power-supply rejection ratio ⁽³⁾	VDD at 3.6 V and 1.6 V		0.1		%/V
POWER SUPPLY						

7.5 Electrical Characteristics (continued)

All specifications at TA = 25°C, VDD = 3.3 V, 800-ms conversion-time (CONVERSION_TIME=0xB), automatic full-scale range, white LED and normal-angle incidence of light, unless otherwise specified.

PARAMETER		TEST CONDITIONS	MIN	TYP	MAX	UNIT
V _{DD}	Power supply		1.6		3.6	V
V _{I2C}	Power supply for I ² C pull up resistor	I ² C pullup resistor, V _{DD} ≤ V _{I2C}	1.6		5.5	V
I _{QACTIVE}	Active Current	Dark		22		μA
		Full-scale lux		30		μA
I _Q	Quiescent current	Dark		1.6		μA
		Full-scale lux		2		μA
POR	Power-on-reset threshold			0.8		V
DIGITAL						
C _{IO}	I/O Pin Capacitance			3		pF
T _{ss}	Trigger to Sample Start	Low-power shutdown mode		0.5		ms
V _{IL}	Low-level input voltage (SDA, SCL, and ADDR)		0		0.3 X V _{DD}	V
V _{IH}	High-level input voltage (SDA, SCL, and ADDR)		0.7 X V _{DD}		5.5	V
I _{IL}	Low-level input current (SDA, SCL, and ADDR)			0.01	0.25 ⁽⁵⁾	μA
V _{OL}	Low-level output voltage (SDA and INT)	I _{OL} =3mA			0.32	V
I _{ZH}	Output logic high, high-Z leakage current (SDA, INT)	Measured with V _{DD} at pin		0.01	0.25 ⁽⁵⁾	μA
TEMPERATURE						
	Specified temperature range		-40		85	°C

- (1) Tested with the white LED calibrated to 2000 lux
- (2) Characterized by measuring fixed near-full-scale light levels on the higher adjacent full-scale range setting.
- (3) PSRR is the percent change of the measured lux output from the current value, divided by the change in power supply voltage, as characterized by results from 3.6-V and 1.6-V power supplies
- (4) The conversion-time, from start of conversion until the data are ready to be read, is the integration-time plus analog-to-digital conversion-time.
- (5) The specified leakage current is dominated by the production test equipment limitations. Typical values are much smaller

7.6 Typical Characteristics

At $T_A = 25^\circ\text{C}$, $V_{DD} = 3.3\text{ V}$, 800-ms conversion time (CONVERSION_TIME = 0xB), automatic full-scale range (RANGE = 0xC), white LED, and normal-angle incidence of light, unless otherwise specified.

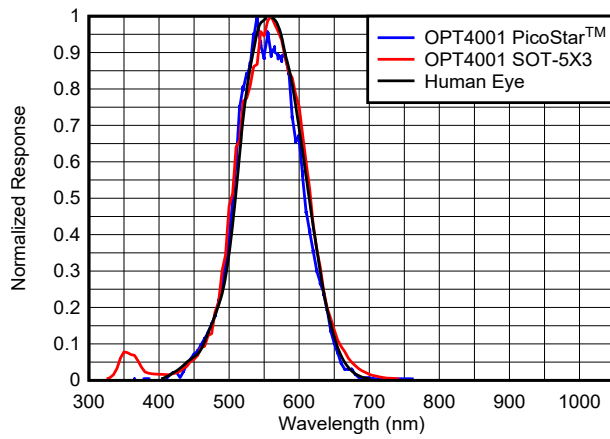

7-1. Spectral Response vs Wavelength

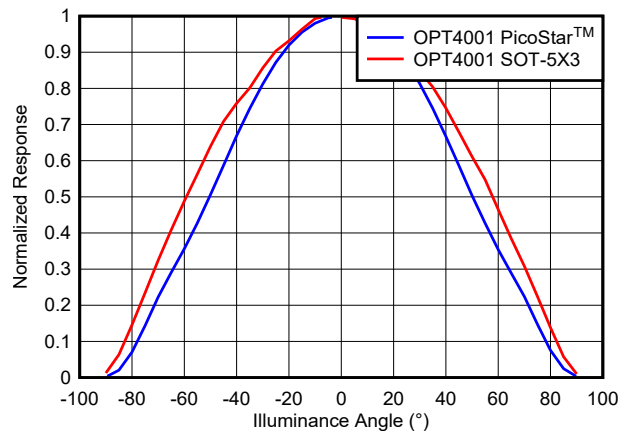

Normalized to 0°

7-2. Device Response vs Illuminance Angle

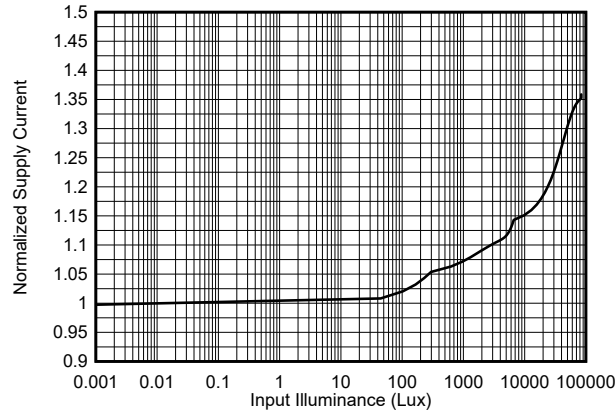

Normalized to dark condition

7-3. Active Current vs Input Light Level

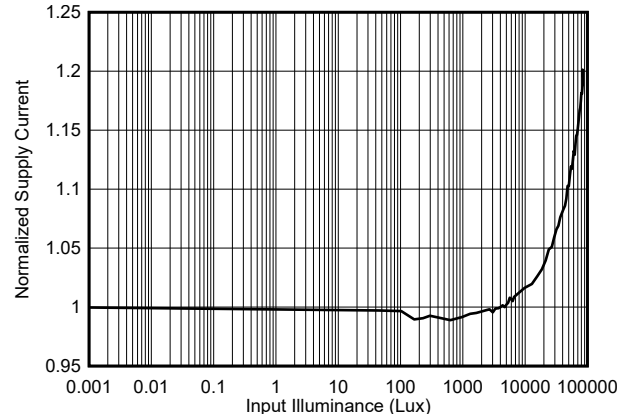

Normalized to dark condition

7-4. Standby Current vs Input Light Level

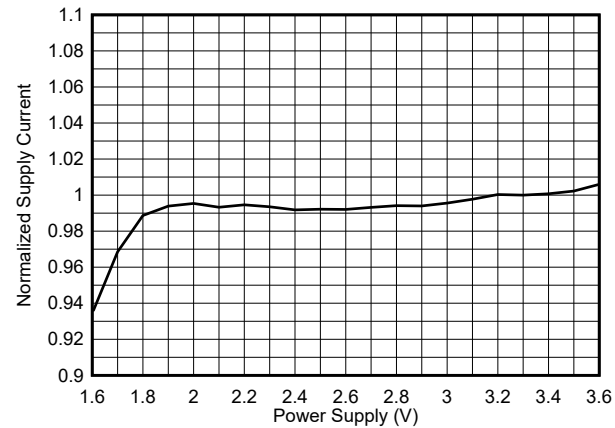

Normalized to 3.3 V

7-5. Active Current vs Power Supply

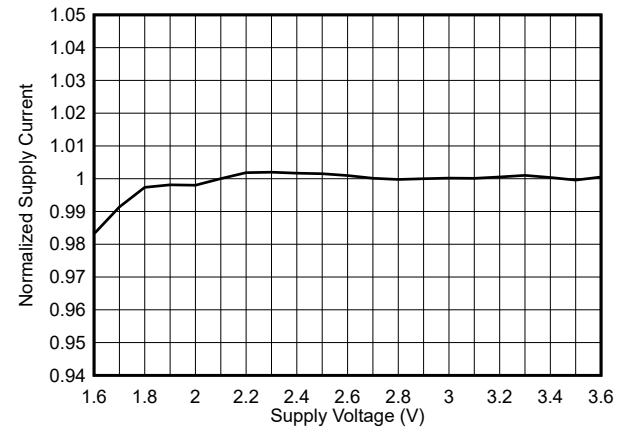

Normalized to 3.3 V

7-6. Standby Current vs Power Supply

7.6 Typical Characteristics (continued)

At $T_A = 25^\circ\text{C}$, $V_{DD} = 3.3\text{ V}$, 800-ms conversion time (CONVERSION_TIME = 0xB), automatic full-scale range (RANGE = 0xC), white LED, and normal-angle incidence of light, unless otherwise specified.

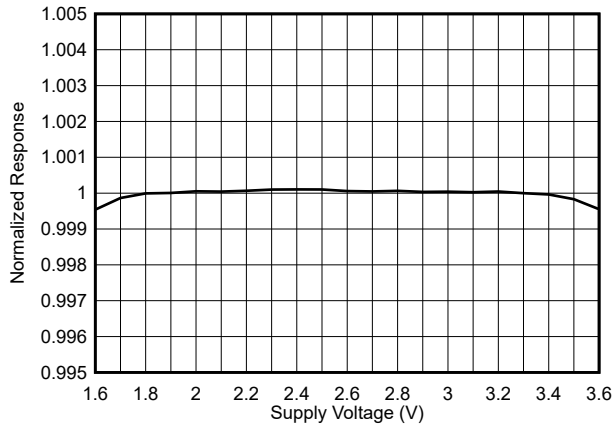

Normalized to 3.3 V

7-7. Device Response vs Power Supply

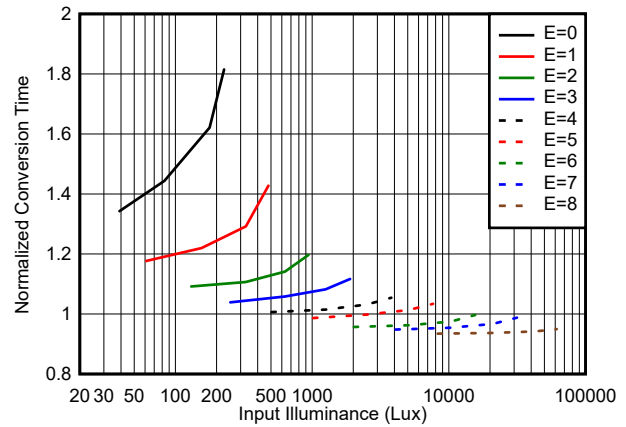

Register E (exponent) denotes the full-scale range
Normalized to 600 μs

7-8. Conversion Time at 600 μs vs Input Light Level

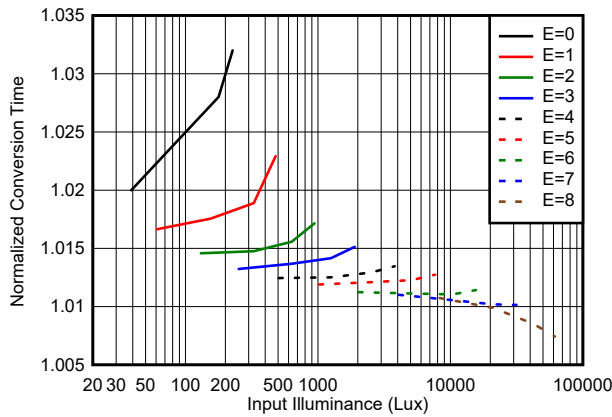

Register E (exponent) denotes the full-scale range
Normalized to 25 ms

7-9. Conversion Time at 25 ms vs Input Light Level

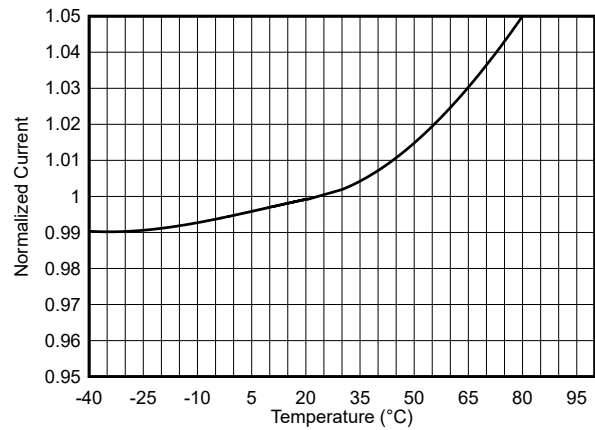

Normalized to 25°C

7-10. Active Current vs Temperature

7.6 Typical Characteristics (continued)

At $T_A = 25^\circ\text{C}$, $V_{DD} = 3.3\text{ V}$, 800-ms conversion time (CONVERSION_TIME = 0xB), automatic full-scale range (RANGE = 0xC), white LED, and normal-angle incidence of light, unless otherwise specified.

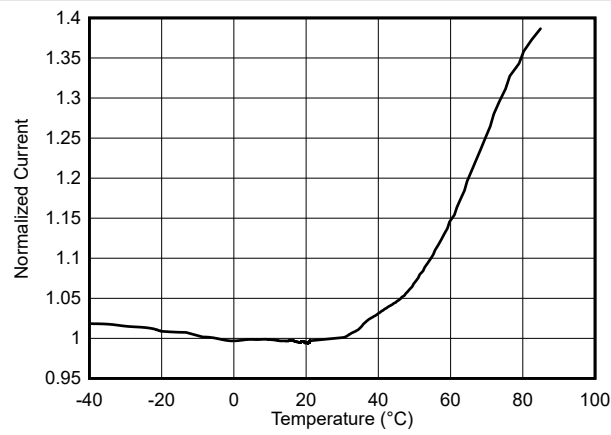

Normalized to 25°C

7-11. Standby Current vs Temperature

8 Detailed Description

8.1 Overview

OPT4001 measures the ambient light that illuminates the device. This device measures light with a spectral response very closely matched to the human eye, and with excellent infrared rejection.

Matching the sensor spectral response to that of the human eye response is vital because ambient light sensors are used to measure and help create excellent human lighting experiences. Strong rejection of infrared light, which a human does not see, is a crucial component of this matching. This matching makes the OPT4001 especially good for operation underneath windows that are visibly dark, but infrared transmissive.

OPT4001 is fully self-contained to measure the ambient light and report the result in ADC codes directly proportional to lux digitally over the I²C bus. The result can also be used to alert a system and interrupt a processor with the INT pin (with SOT-5X3 package variant). The result can also be summarized with a programmable threshold comparison and communicated with the INT pin (with SOT-5X3 package variant).

OPT4001 is by default configured to operate in automatic full-scale range detection mode that always selects the best full-scale range setting for the given lighting conditions. There are 9 full-scale range settings, one of which can be selected manually as well. Setting the device to operate in automatic full-scale range detection mode frees the user from having to program their software for potential iterative cycles of measurement and readjustment of the full-scale range until good for any given measurement. With device exhibiting excellent linearity over the entire 28 bit dynamic range of measurement no additional linearity calibration is required at system level.

OPT4001 can be configured to operate in continuous or one-shot measurement modes. The device offers 12 conversion times ranging from 600 μ s to 800 ms. The device starts up in a low-power shutdown state, such that the OPT4001 only consumes active-operation power after being programmed into an active state.

OPT4001 optical filtering system is not excessively sensitive to small particles and micro-shadows on the optical surface. This reduced sensitivity is a result of the relatively minor device dependency on uniform density optical illumination of the sensor area for infrared rejection. Proper optical surface cleanliness is always recommended for best results on all optical devices.

8.2 Functional Block Diagram

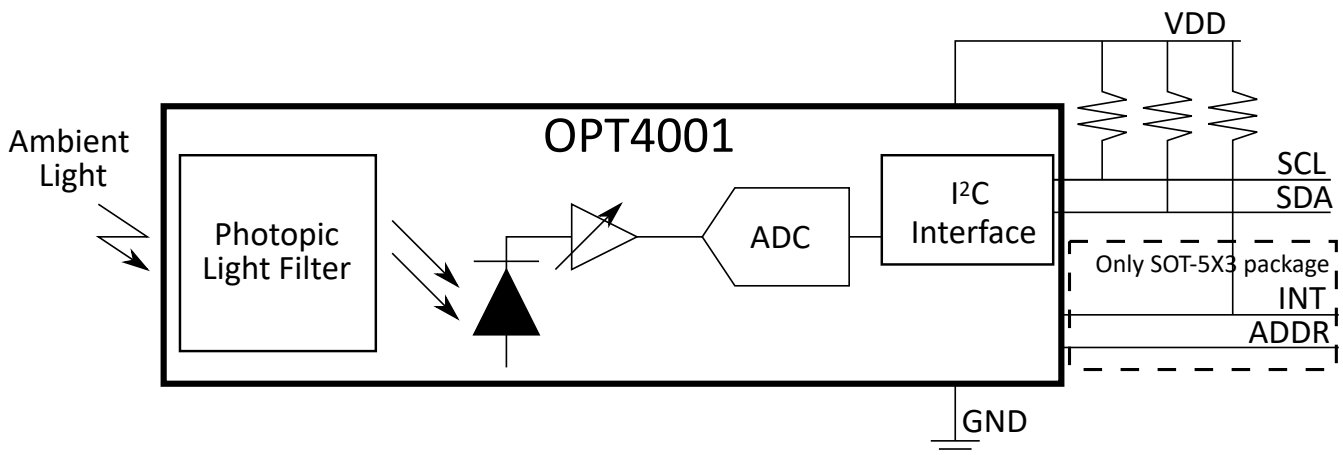

8-1. Functional Block Diagram of OPT4001

8.3 Feature Description

8.3.1 Spectral Matching to Human Eye

OPT4001 spectral response closely matches that of the human eye. If the ambient light sensor measurement is used to help create a good human experience, or create optical conditions that are good for humans, then the sensor must measure the same spectrum of light that a human sees.

OPT4001 also has excellent infrared light (IR) rejection. This IR rejection is especially important because many real-world lighting sources have significant infrared content that humans do not see. If the sensor measures infrared light that the human eye does not see, then a true human experience is not accurately represented.

If the application demands hiding OPT4001 underneath dark window (such that the end-product user cannot see the sensor) the infrared rejection of the OPT4001 becomes significantly more important because many dark windows attenuate visible light but transmit infrared light. This attenuation of visible light and lack of attenuation of IR light amplifies the ratio of the infrared light to visible light that illuminates the sensor. Results can still be well matched to the human eye under this condition because of the high infrared rejection of the OPT4001.

8.3.2 Automatic Full-Scale Range Setting

The OPT4001 has an automatic full-scale range setting feature that eliminates the need to predict and set the best range for the device. In this mode, the device automatically selects the best full-scale range for varying lighting condition each measurement. The device has a high degree of result matching between the full-scale range settings. This matching eliminates the problem of varying results or the need for range-specific, user-calibrated gain factors when different full-scale ranges are chosen.

8.3.3 Output Register CRC and Counter

OPT4001 device features additional bits as part of the output register which helps in improving the reliability of light measurements for the application.

8.3.3.1 Output Sample Counter

The OPT4001 device features a register **COUNTER** as part of the output registers which increments for every successful measurement. This register can be read as part of the output registers which helps the application to keep track of measurements. The 4 bit counter starts at 0 on power-up and counts up to 15 after which the counter resets back to 0 and continues to count up, which is particularly helpful in situations like the following:

- Host or the controller needs consecutive measurements. Utilizing the **COUNTER** register allows the controller to compare samples and makes sure that the samples are in expected order without missing intermediate counter values.
- As a safety feature where when light level are not changing, the controller can make sure that the measurements from OPT4001 are not stuck by comparing values of register **COUNTER** between measurements. If the **COUNTER** values continue to change over samples, the device is updating the output register with the most recent measurement of light levels.

8.3.3.2 Output CRC

CRC register consists of Cyclic Redundancy Checker bits part of the output registers calculated within the OPT4001 device and updated on every measurement. This feature helps in detecting communication related bit errors during the output readout from the device. The calculation method for the **CRC** bits is shown in [Figure 8-14](#), which can be independently verified in the controller or host firmware/software to validate if communication between the controller and the device was successful without bit errors during transmission.

8.3.4 Output Register FIFO

Output registers always contain the most recent light measurement. Along with output registers there are 3 more shadow registers which have the data from the previous 3 measurements. For every new measurement, the data on the 3 shadow registers are updated to contain the most recent measurements discarding the oldest measurement similar to a FIFO scheme. These shadow registers along with output registers act like a FIFO with a depth of 4. The INT pin (only on SOT-5X3 variant) can be configured as shown in the figure below to generate an interrupt every measurement or can be configured to generate an interrupt every 4 measurements using the

register `INT_CFG`. This way the controller reading data from OPT4001 device can minimize the number of interrupts by a factor of 4 and still get access to all the four measurements between the interrupts. By using the **Burst Read Mode** the output and FIFO registers can be read out with minimal I²C clocks.

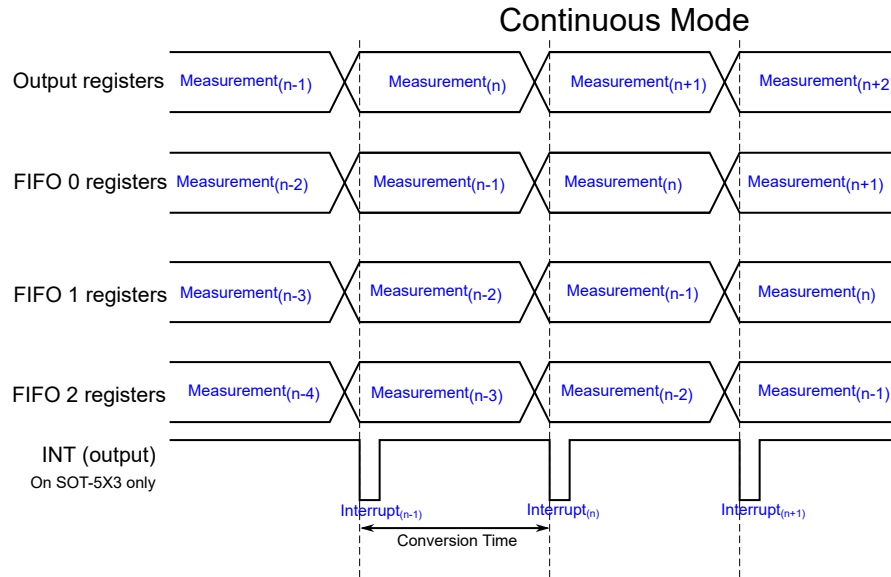

8-2. FIFO registers data movement

8.3.5 Threshold Detection

OPT4001 features a threshold detection logic which can be programmed to indicate and update register flags if measured light levels cross thresholds set by the user. There are independent low and high threshold target registers with independent flag registers to indicate the status of measured light level. Measured light level reaching below low threshold and above the high threshold are called faults. Users can program a fault count register, which counts consecutive number of faults before the flag registers are set. This is particularly useful in cases where the controller can read the flag register alone to get indication of measured light level not really needing to do the lux calculations. Details on the register and setting up the threshold is available in [セクション 8.3.5](#) and calculations for setting this up is available in [Threshold Detection Calculations](#).

8.4 Device Functional Modes

8.4.1 Modes of Operation

The OPT4001 device has the following modes of operation:

- **Power-down mode:** This is power-down or standby mode where the device enters a low power state. There is no active light sensing or conversion in this mode. Device still responds to I²C transactions which can be utilized to bring the device out of this mode. Register `OPERATING_MODE` is set to 0.
- **Continuous mode:** In this mode OPT4001 measures and updates the output registers continuously determined by the conversion time and generates hardware interrupt on pin INT (Only on SOT-5X3 package variant) for every successful conversion. TI recommends to configure the INT pin in output mode using the `INT_DIR` register. The device active circuits are continuously kept active to minimize the interval between measurements. Register `OPERATING_MODE` is set to 3.
- **One shot mode of operation:** There are several ways in which OPT4001 can be used in one shot mode of operation with one common theme where OPT4001 stays in standby mode and a conversion is triggered either by a register write to configuration register or hardware interrupt on the INT pin.

There are two types of one shot modes.

- **Force auto-range one shot mode:** Every one shot trigger forces a full reset on auto-ranging control logic and a fresh auto-range detection is initiated ignoring the previous measurements. This is particularly useful in situations where lighting conditions are expected to change a lot and one shot trigger frequency is not very often. There is small penalty on conversion time due for the auto-ranging logic to recover from

reset state. The full reset cycle on the auto-ranging control logic takes around 500 μ s which needs to be accounted for between measurements when this mode is used. Register OPERATING_MODE is set to 1.

- **Regular auto-range one shot mode:** Auto-range selection logic utilizes the information from the previous measurements to decide the range for the current trigger. This mode is recommended only when the device needs time synchronized measurements with frequent triggers from the controller. In other words, this mode can be used as an alternative to continuous mode the key difference being that the interval between measurements is determined by the one shot triggers. Register OPERATING_MODE is set to 2.

One Shot can be triggered by the following

- **Hardware trigger (Only on SOT-5X3 variant):** INT pin can be configured to be an input to trigger a measurement setting INT_DIR register to 0. Since INT pin is used as input, there is no hardware interrupt to indicate completion of measurement. The controller needs to keep time from the trigger mechanism and read out output registers.
- **Register trigger:** An I²C write to the OPERATING_MODE register triggers a measurement (value of 1 or 2). The register value is reset after next successful measurement. INT pin can be configured to indicate measurement completion to read out output registers setting the INT_DIR register to 1.

TI highly recommends to set the interval between subsequent triggers to account for all the aspects involved in the trigger mechanism like the I²C transaction time, device wake-up time, auto-range time (if used) and device conversion time. If a conversion trigger is received before the completion of current measurement, the device simply ignores the new request until the previous conversion is completed.

Since the device enters standby after each one shot trigger, measurement interval in the one shot trigger mechanism needs to account for additional time T_{ss} as specified in the specification table for the circuits to recover from standby state. However setting the quick wake up register QWAKE eliminates the need for this additional T_{ss} at the cost of not powering down the active circuit with device not entering the standby mode between triggers.

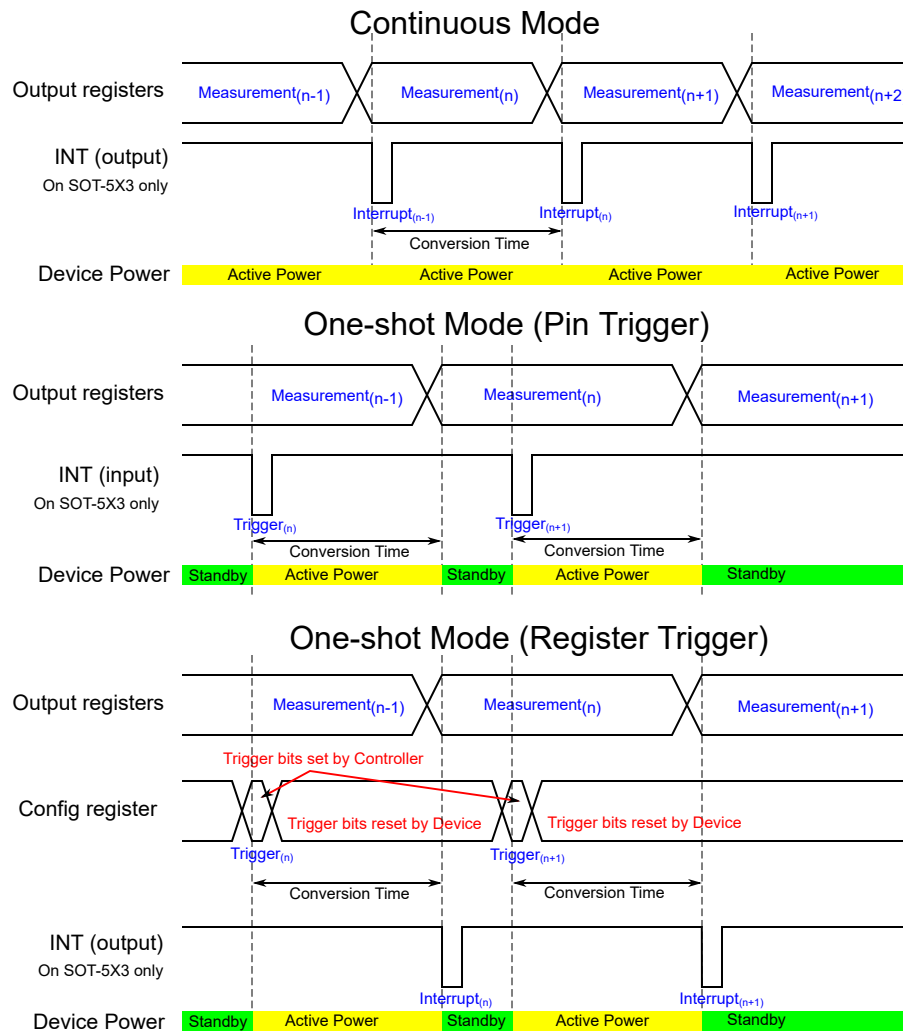

8-3. Timing Diagrams for different Operating modes

8.4.2 Interrupt Modes of Operation

The device has an interrupt reporting system that allows the processor connected to the I²C bus to go to sleep, or otherwise ignore the device results, until a user-defined event occurs that requires possible action. Alternatively, this same mechanism can also be used with any system that can take advantage of a single digital signal that indicates whether the light is above or below levels of interest.

The INT pin has an open-drain output, which requires the use of a pull-up resistor. This open-drain output allows multiple devices with open-drain INT pins to be connected to the same line, thus creating a logical *NOR* or *AND* function between the devices. The polarity of the INT pin can be controlled by the [INT_POL](#).

There are two major types of interrupt reporting mechanism modes: latched window comparison mode and transparent hysteresis comparison mode. The configuration register [LATCH](#) controls which of these two modes is used. [表 8-1](#) and [图 8-4](#) summarize the function of these two modes. Additionally, the INT pin can either be used to indicate a fault in one of these modes ([INT_CFG=0](#)) or to indicate a conversion completion ([INT_CFG >0](#)). This is shown in [表 8-2](#).



图 8-4. Interrupt Pin Status (for INT_CFG=0 setting) and Register Flag Behavior

表 8-1. Interrupt Pin Status (for INT_CFG=0 setting) and Register Flag Behavior

LATCH Setting	INT Pin State (when INT_CFG=0)	FLAG_H Value	FLAG_L Value	Latching Behavior
0: Transparent hysteresis mode	INT pin indicates if measurement is above (INT active) or below (INT inactive) the threshold. If measurement is between the high and low threshold values then the previous INT value is maintained. This prevents the INT pin from repeated toggling when the measurement values are close to the threshold.	0: If measurement is below the low limit 1: If measurement is above the high limit If measurement is between high and low limits previous value is maintained	0: If measurement is above the high limit 1: If measurement is below the low limit If measurement is between high and low limits previous value is maintained	Not latching: Values are updated after each conversion
1: Latched window mode	INT pin becomes active if the measurement is outside the window (above high threshold or below the low threshold). The INT pin does not reset and return to the inactive state until register 0xC is read.	1: If measurement is above the high limit	1: If measurement is below the low limit	Latching: INT pin, FLAG_H and FLAG_L values do not reset until the register 0x0C is read.

The [THRESHOLD_H](#), [THRESHOLD_L](#), [LATCH](#) and [FAULT_COUNT](#) registers control the interrupt behavior. The [LATCH](#) field setting allows a choice between the latched window mode and transparent hysteresis mode as shown in the table. Interrupt reporting can be observed on INT pin (for SOT-5X3 variant only), the [FLAG_H](#), and the [FLAG_L](#) registers.

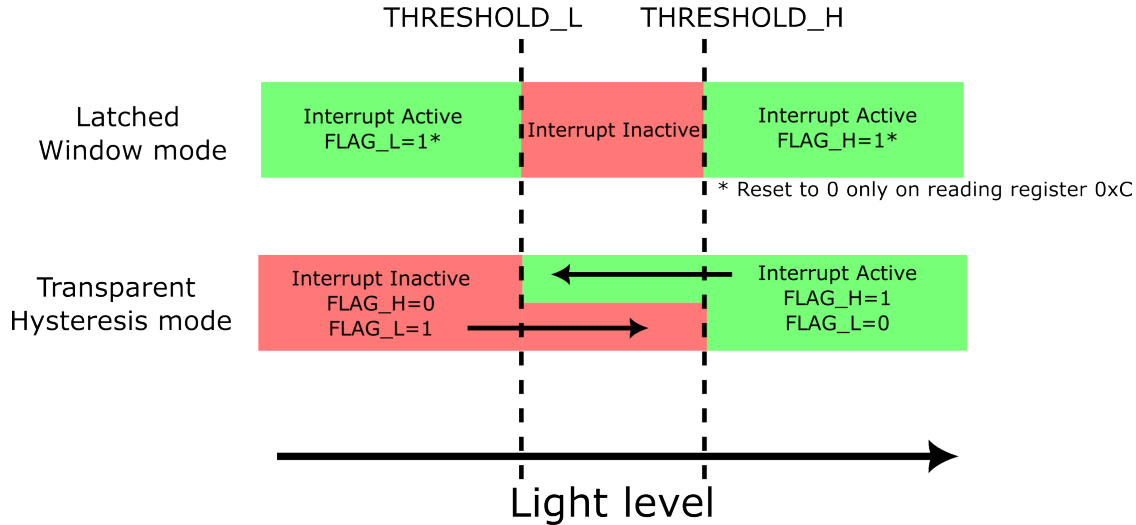
Results from comparing the current sensor measurements with [THRESHOLD_H](#) and [THRESHOLD_L](#) registers are referred to as *fault events*. The calculations to set these registers can be found in [Threshold Detection Calculations](#). The [FAULT_COUNT](#) register dictates the number of continuous *fault events* required to trigger an interrupt event and subsequently change the state of the interrupt reporting mechanisms. For example, with a [FAULT_COUNT](#) value of 2 corresponding to 4 fault counts, the INT pin (for SOT-5X3 variant only), [FLAG_H](#) and [FLAG_L](#) states shown in the table are not realized unless 4 consecutive measurements are taken that satisfy the fault condition.

INT pin function (for SOT-5X3 variant only) listed in [表 8-1](#) is valid only when [INT_CFG=0](#). The INT pin function can be changed to indicate an end of conversion or FIFO full state as shown in [表 8-2](#). The [FLAG_H](#) and

FLAG_L registers continue to behave as listed in [表 8-1](#) even while **INT_CFG**>0. The polarity of the INT pin is controlled by the **INT_POL** register.

表 8-2. INT_CFG Setting and Resulting INT Pin Behavior

INT_CFG Setting	INT Pin Function
0	As per 表 8-1
1	INT pin asserted with 1us pulse width after every conversion
3	INT pin asserted with 1us pulse width every 4 conversions to indicate the FIFO is full

8.4.3 Light Range Selection

The OPT4001 has an automatic full-scale-range setting mode that eliminates the need for a user to predict and set the best range for the device. This mode is entered when register **RANGE** is set to 0xC. The device determines the appropriate full-scale range to take the measurement based on a combination of current lighting conditions and the previous measurement.

If a measurement is towards the low side of full-scale, then the full-scale range is decreased by one or two settings for the next measurement. If a measurement is towards the upper side of full-scale, the full-scale range is increased by one setting for the next measurement.

If the measurement exceeds the full-scale range, resulting from a fast increasing optical transient event, then the current measurement is aborted. This invalid measurement is not reported. If the scale is not at the maximum, then the device increases the scale by one step and a new measurement is retaken with that scale. Therefore, during a fast increasing optical transient in this mode, a measurement can possibly take longer to complete and report than indicated by the configuration register **CONVERSION_TIME**.

TI highly recommends to use this feature, since the device selects the best range setting based on lighting condition. However, there is an option to manually set the range. Setting the range manually turns off the automatic full-scale selection logic and the device operates for a particular range setting.

表 8-3. Range Selection Table

RANGE register setting	Typical Full-scale Light level for PicoStar™ variant	Typical Full-scale Light level for SOT-5X3 variant
0	328 lux	459 lux
1	655 lux	918 lux
2	1311 lux	1835 lux
3	2621 lux	3670 lux
4	5243 lux	7340 lux
5	10486 lux	14680 lux
6	20972 lux	29360 lux
7	41943 lux	58720 lux
8	83886 lux	117441 lux
12	Determined by automatic full-scale range logic	

8.4.4 Selecting Conversion Time

The OPT4001 device offers several conversion times to select from. Conversion Time is defined as how much time for one measurement to complete and update the results in output register from the time measurement is initiated. Measurement initiation is determined by the mode of operation as specified in [Modes of Operation](#).

表 8-4. Conversion Time Selection

CONVERSION_TIME register	Typical Conversion Time
0	0.6 ms
1	1 ms
2	1.8 ms
3	3.4 ms
4	6.5 ms
5	12.7 ms
6	25 ms
7	50 ms
8	100 ms
9	200 ms
10	400 ms
11	800 ms

8.4.5 Light Measurement in Lux

The OPT4001 device measures light and updates output registers with proportional ADC codes. Output of the device is represented by two parts (i) 4 bits of [EXPONENT](#) and (ii) 20 bits of [MANTISSA](#). This arrangement of binary logarithmic full-scale range with linear representation with in a range helps in covering a large dynamic range of measurements. [MANTISSA](#) represents the linear ADC codes proportional to the measured light within a given full-scale range and the [EXPONENT](#) represents the current-full scale range selected. The selected range can be automatically determined by the auto-range selection logic or manually selected as per [表 8-3](#).

Lux level can be determined using the following equations:

$$\text{MANTISSA} = (\text{RESULT_MSB} \ll 8) + \text{RESULT_LSB} \quad (1)$$

or

$$\text{MANTISSA} = (\text{RESULT_MSB} \times 2^8) + \text{RESULT_LSB} \quad (2)$$

where [RESULT_MSB](#), [RESULT_LSB](#) and [EXPONENT](#) are parts of the output register

RESULT_MSB register carries the most significant 12 bits of the MANTISSA and RESULT_LSB register carries the least significant 8 bits of the MANTISSA. MANTISSA is then computed using the above equations to get the 20 bit number. EXPONENT is directly read from the register which is 4 bits.

Once the EXPONENT and MANTISSA portions are calculated the linearized ADC_CODES is calculated using the following equation:

$$\text{ADC_CODES} = (\text{MANTISSA} \ll \text{E}) \tag{3}$$

or

$$\text{ADC_CODES} = (\text{MANTISSA} \times 2^{\text{E}}) \tag{4}$$

With maximum value for register E being 8 ADC_CODES is effectively a 28 bit number. The semi-logarithmic numbers have been converted to a linear ADC_CODES representation, which is simple to convert to lux given by the following formula

$$\text{lux} = \text{ADC_CODES} \times 312.5\text{E-}6 \text{ for the PicoStar™ variant} \tag{5}$$

$$\text{lux} = \text{ADC_CODES} \times 437.5\text{E-}6 \text{ for the SOT-5X3 variant} \tag{6}$$

The MANTISSA and ADC_CODES are large numbers with 20 and 28 bits required to represent them. While developing firmware or software for these calculations, allocating appropriate data types to prevent data overflow is important. Some explicit typecasting to a larger data type such as 32 bit representation before left shift operation (<<) operations is recommended.

Threshold Detection Calculations

Threshold result registers [THRESHOLD_H_RESULT](#) and [THRESHOLD_L_RESULT](#) are 12 bit, while threshold exponent registers [THRESHOLD_H_EXPONENT](#) and [THRESHOLD_L_EXPONENT](#) are 4 bits. Since threshold is compared at linear ADC_CODES, the threshold registers are padded with zeros internally as shown to compare with the ADC_CODES

$$\text{ADC_CODES_TH} = \text{THRESHOLD_H_RESULT} \ll (8 + \text{THRESHOLD_H_EXPONENT}) \tag{7}$$

or

$$\text{ADC_CODES_TH} = \text{THRESHOLD_H_RESULT} \times 2^{(8 + \text{THRESHOLD_H_EXPONENT})} \tag{8}$$

and

$$\text{ADC_CODES_TL} = \text{THRESHOLD_L_RESULT} \ll (8 + \text{THRESHOLD_L_EXPONENT}) \tag{9}$$

or

$$\text{ADC_CODES_TL} = \text{THRESHOLD_L_RESULT} \times 2^{(8 + \text{THRESHOLD_L_EXPONENT})} \tag{10}$$

Threshold are then compared as shown to detect *fault events*.

$$\text{If } \text{ADC_CODES} < \text{ADC_CODES_TL} \text{ a } \textit{fault low} \text{ is detected} \tag{11}$$

and

$$\text{If } \text{ADC_CODES} > \text{ADC_CODES_TH} \text{ a } \textit{fault high} \text{ is detected} \tag{12}$$

Based on the [FAULT_COUNT](#) register setting, with consecutive *fault high* or *fault low* events, respective [FLAG_H](#) and [FLAG_L](#) registers are set, more details of which can be found in [セクション 8.4.2](#). Understanding the relation between [THRESHOLD_H_EXPONENT](#), [THRESHOLD_H_RESULT](#), [THRESHOLD_L_EXPONENT](#),

THRESHOLD_L_RESULT and the output registers is important to be able to set appropriate threshold based on application needs.

8.4.6 Light Resolution

The OPT4001 device's effective resolution is dependent on both the conversion time setting and the full-scale light range. Although the LSB resolution of the linear ADC_CODES doesn't change, the effective or useful resolution of the device is dependent on the conversion time setting and the full-scale range as per the table below. In conversion times where the effective resolution is lower, the LSBs are padded with 0.

表 8-5. Resolution Table for the Picostar™ Variant

CONVERSION_TIME register	Conversion Time	MANTESA effective bits	EXPONENT	0	1	2	3	4	5	6	7	8
			Full-scale lux	328	655	1310	2621	5243	10486	20972	41943	83886
Effective Resolution in lux												
0	600us	9		640 m	1.28	2.56	5.12	10.24	20.48	40.96	81.92	163.84
1	1 ms	10		320 m	640 m	1.28	2.56	5.12	10.24	20.48	40.96	81.92
2	1.8 ms	11		160 m	320 m	640 m	1.28	2.56	5.12	10.24	20.48	40.98
3	3.4 ms	12		80 m	160 m	320 m	640 m	1.28	2.56	5.12	10.24	20.48
4	6.5 ms	13		40 m	80 m	160 m	320 m	640 m	1.28	2.56	5.12	10.24
5	12.7 ms	14		20 m	40 m	80 m	160 m	320 m	640 m	1.28	2.56	5.12
6	25 ms	15		10 m	20 m	40 m	80 m	160 m	320 m	640 m	1.28	2.56
7	50 ms	16		5 m	10 m	20 m	40 m	80 m	160 m	320 m	640 m	1.28
8	100 ms	17		2.5 m	5 m	10 m	20 m	40 m	80 m	160 m	320 m	640 m
9	200 ms	18		1.25 m	2.5 m	5 m	10 m	20 m	40 m	80 m	160 m	320 m
10	400 ms	19		0.625 m	1.25 m	2.5 m	5 m	10 m	20 m	40 m	80 m	160 m
11	800 ms	20		0.3125 m	0.625 m	1.25 m	2.5 m	5 m	10 m	20 m	40 m	80 m

表 8-6. Resolution Table for the SOT-5X3 variant

CONVERSION_TIME register	Conversion Time	MANTESA effective bits	EXPONENT	0	1	2	3	4	5	6	7	8
			Full-scale lux	459	918	1835	3670	7340	14680	29360	58720	117441
Effective Resolution in lux												
0	600 us	9		896 m	1.792	3.584	7.168	14.336	28.672	47.344	114.688	229.376
1	1 ms	10		448 m	896 m	1.792	3.584	7.168	14.336	28.672	47.344	114.688
2	1.8 ms	11		224 m	448 m	896 m	1.792	3.584	7.168	14.336	28.672	47.344
3	3.4 ms	12		112 m	224 m	448 m	896 m	1.792	3.584	7.168	14.336	28.672
4	6.5 ms	13		56 m	112 m	224 m	448 m	896 m	1.792	3.584	7.168	14.336
5	12.7 ms	14		28 m	56 m	112 m	224 m	448 m	896 m	1.792	3.584	7.168
6	25 ms	15		14 m	28 m	56 m	112 m	224 m	448 m	896 m	1.792	3.584
7	50 ms	16		7 m	14 m	28 m	56 m	112 m	224 m	448 m	896 m	1.792
8	100 ms	17		3.5 m	7 m	14 m	28 m	56 m	112 m	224 m	448 m	896 m
9	200 ms	18		1.75 m	3.5m	7 m	14 m	28 m	56 m	112 m	224 m	448 m
10	400 ms	19		0.875 m	1.75m	3.5 m	7 m	14 m	28 m	56 m	112 m	224 m
11	800 ms	20		0.4375 m	0.875 m	1.75 m	3.5 m	7 m	14 m	28 m	56 m	112 m

8.5 Programming

The OP4001 supports the transmission protocol for standard mode (up to 100 kHz), fast mode (up to 400 kHz), and high-speed mode (up to 2.6 MHz). Fast and standard modes are described as the default protocol, referred to as *F/S*. High-speed mode is described in the [High-Speed I2C Mode](#) section.

8.5.1 I²C Bus Overview

The OPT4001 offers compatibility with both I²C and SMBus interfaces. The I²C and SMBus protocols are essentially compatible with one another. The I²C interface is used throughout this document as the primary example with the SMBus protocol specified only when a difference between the two protocols is discussed.

The device is connected to the bus with two pins: an SCL clock input pin and an SDA open-drain bidirectional data pin. The bus must have a controller device that generates the serial clock (SCL), controls the bus access, and generates start and stop conditions. To address a specific device, the controller initiates a start condition by pulling the data signal line (SDA) from a high logic level to a low logic level while SCL is high. All targets on the bus shift in the target address byte on the SCL rising edge, with the last bit indicating whether a read or write operation is intended. During the ninth clock pulse, the target being addressed responds to the controller by generating an acknowledge bit by pulling SDA low.

Data transfer is then initiated and eight bits of data are sent, followed by an acknowledge bit. During data transfer, SDA must remain stable while SCL is high. Any change in SDA while SCL is high is interpreted as a start or stop condition. When all data are transferred, the controller generates a stop condition, indicated by pulling SDA from low to high while SCL is high. The device includes a 28-ms timeout on the I²C interface to prevent locking up the bus. If the SCL line is held low for this duration of time, the bus state machine is reset.

8.5.1.1 Serial Bus Address

To communicate with the OPT4001, the controller must first initiate an I²C start command. Then, the controller must address target devices via a target address byte. The target address byte consists of a seven bit address and a direction bit that indicates whether the action is to be a read or write operation.

For the SOT 5X3 variant, four I²C addresses are possible by connecting the ADDR pin to one of four pins: GND, VDD, SDA, or SCL. Table below summarizes the possible addresses with the corresponding ADDR pin configuration. The state of the ADDR pin is sampled on every bus communication and must be driven or connected to the desired level before any activity on the interface occurs.

ADDR PIN CONNECTION	DEVICE I ² C ADDRESS
GND	1000100
VDD	1000101
SDA	1000110
SCL	1000101

In case of the PicoStar™ variant there is no target address selection capability and the device address is hard coded to 1000101b (0x45).

8.5.1.2 Serial Interface

The OPT4001 operates as a target device on both the I²C bus and SMBus. Connections to the bus are made via the SCL clock input line and the SDA open-drain I/O line. The device supports the transmission protocol for standard mode (up to 100 kHz), fast mode (up to 400 kHz), and high-speed mode (up to 2.6 MHz). All data bytes are transmitted most-significant bits first.

The SDA and SCL pins feature integrated spike-suppression filters and Schmitt triggers to minimize the effects of input spikes and bus noise. See the [セクション 9.2.1](#) for further details of the I²C bus noise immunity.

8.5.2 Writing and Reading

Accessing a specific register on the OPT4001 is accomplished by writing the appropriate register address during the I²C transaction sequence. Refer to [セクション 8.6](#) for a complete list of registers and their corresponding register addresses. The value for the register address (as shown in [図 8-5](#)) is the first byte transferred after the target address byte with the R/W bit low.

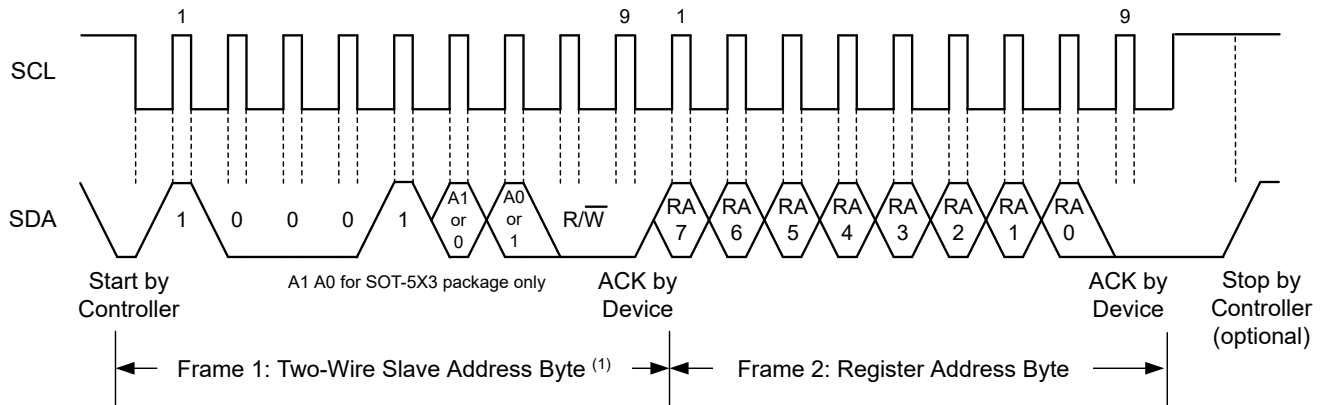
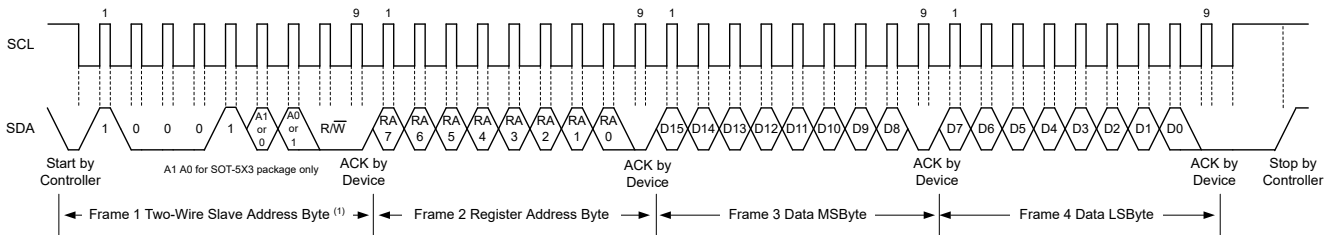

FIG 8-5. Setting the I²C Register Address

Writing to a register begins with the first byte transmitted by the controller. This byte is the target address with the R/W bit low. The device then acknowledges receipt of a valid address. The next byte transmitted by the controller is the address of the register that data are to be written to. The next two bytes are written to the register addressed by the register address. The device acknowledges receipt of each data byte. The controller can terminate the data transfer by generating a start or stop condition.

When reading from the device, the last value stored in the register address by a write operation determines which register is read during a read operation. To change the register address for a read operation, a new partial I²C write transaction must be initiated. This partial write is accomplished by issuing a target address byte with the R/W bit low, followed by the register address byte and a stop command. The controller then generates a start condition and sends the target address byte with the R/W bit high to initiate the read command. The next byte is transmitted by the target and is the most significant byte of the register indicated by the register address. This byte is followed by an acknowledge from the controller; then the target transmits the least significant byte. The controller acknowledges receipt of the data byte. The controller can terminate the data transfer by generating a not-acknowledge after receiving any data byte, or by generating a start or stop condition. If repeated reads from the same register are desired, continually sending the register address bytes is not necessary; the device retains the register address until that number is changed by the next write operation.

8-6 and 8-7 show the write and read operation timing diagrams, respectively. Note that register bytes are sent most significant byte first, followed by the least significant byte.



8-6. I²C Write Example

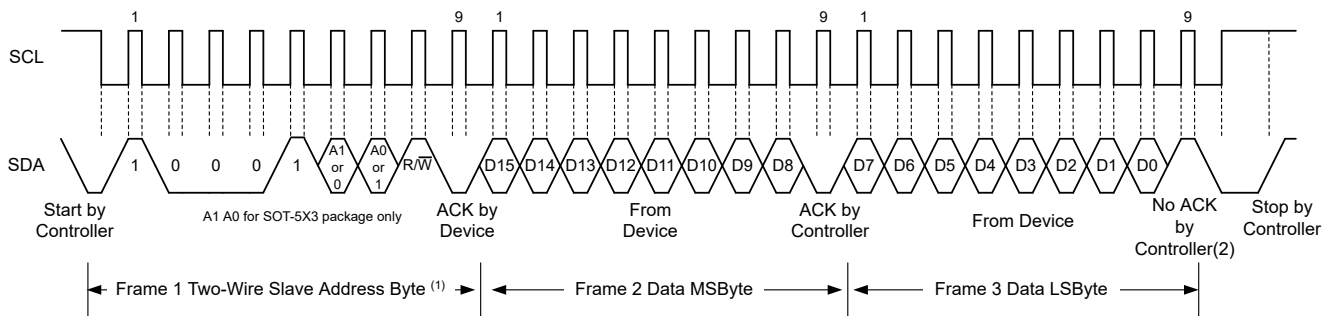

A. An ACK by the controller can also be sent.

8-7. I²C Read Example

8.5.2.1 High-Speed I²C Mode

When the bus is idle, both the SDA and SCL lines are pulled high by the pullup resistors or active pullup devices. The controller generates a start condition followed by a valid serial byte containing the high-speed (HS) controller code 0000 1XXXb. This transmission is made in either standard mode or fast mode (up to 400 kHz). The device does not acknowledge the HS controller code but does recognize the code and switches its internal filters to support a 2.6-MHz operation.

The controller then generates a repeated start condition (a repeated start condition has the same timing as the start condition). After this repeated start condition, the protocol is the same as F/S mode, except that transmission speeds up to 2.6 MHz are allowed. Instead of using a stop condition, use repeated start conditions to secure the bus in HS mode. A stop condition ends the HS mode and switches all internal filters of the device to support the F/S mode.

8.5.2.2 Burst Read Mode

OPT4001 supports I²C burst read mode which helps in minimizing the number of transactions on the bus for efficient data transfer from the device to the controller.

Before considering the burst mode, a regular I²C read transaction involves an I²C write operation to the device read pointer, followed by the actual I²C read operation. If the output registers and FIFO registers which are in continuous locations, are writing the register pointer every 2 bytes, this takes up several clock cycles. With the burst mode enabled, the read pointer address is auto incremented after every register read (2 bytes), eliminating the need write operations to set the pointer for subsequent register reads.

Burst mode can be enabled by setting the register I2C_BURST. When a STOP command is issued the pointer resets to the original register address before the auto-increments.

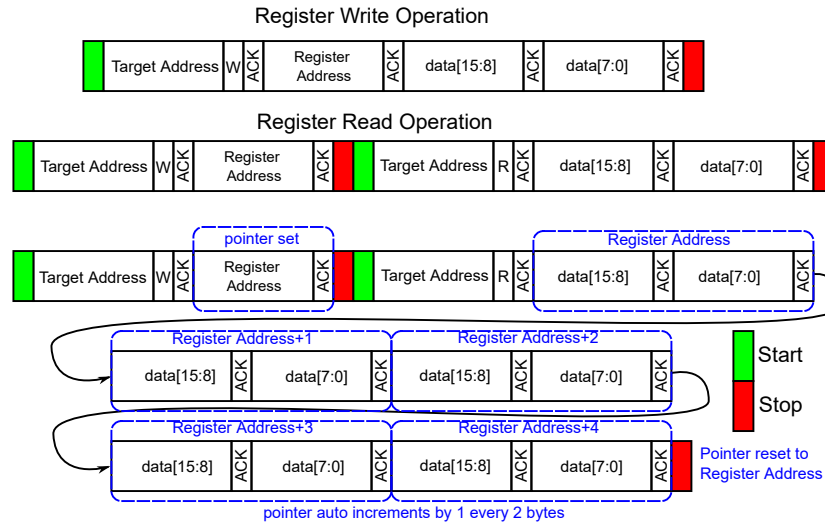

8-8. I²C Operations

8.5.2.3 General-Call Reset Command

The I²C general-call reset allows the host controller in one command to reset all devices on the bus that respond to the general-call reset command. The general call is initiated by writing to the I²C address 0 (0000 0000b). The reset command is initiated when the subsequent second address byte is 06h (0000 0110b). With this transaction, the device issues an acknowledge bit and sets all registers to the power-on-reset default condition.

8.5.2.4 SMBus Alert Response

The SMBus alert response provides a quick identification for which device issued the interrupt. Without this alert response capability, the processor does not know which device pulled the interrupt line when there are multiple target devices connected.

OPT4001 is designed to respond to the SMBus alert response address, when in the latched window-style comparison mode. The OPT4001 does not respond to the SMBus alert response when in transparent mode.

The response behavior of the device to the SMBus alert response is shown in 8-9. When the interrupt line to the processor is pulled to active, the controller can broadcast the alert response target address. Following this alert response, any target devices that generated an alert identify themselves by acknowledging the alert response and sending respective I²C address on the bus. The alert response can activate several different target devices simultaneously. If more than one target attempts to respond, bus arbitration rules apply. The device with the lowest address wins the arbitration. If the OPT4001 loses the arbitration, the device does not acknowledge the I²C transaction and the INT pin remains in an active state, prompting the I²C controller processor to issue a subsequent SMBus alert response. When the OPT4001 wins the arbitration, the device acknowledges the transaction and sets the INT pin to inactive. The controller can issue that same command again, as many times as necessary to clear the INT pin. See [セクション 8.4.2](#) for additional details of how the flags and INT pin are controlled. The controller can obtain information about the source of the OPT4001 interrupt from the address broadcast in the above process. The `FLAG_H` value is sent as the final LSB of the address to provide the controller additional information about the cause of the OPT4001 interrupt. If the controller requires additional information, the result register or the configuration register can be queried. The `FLAG_H` and `FLAG_L` fields are not cleared upon an SMBus alert response.

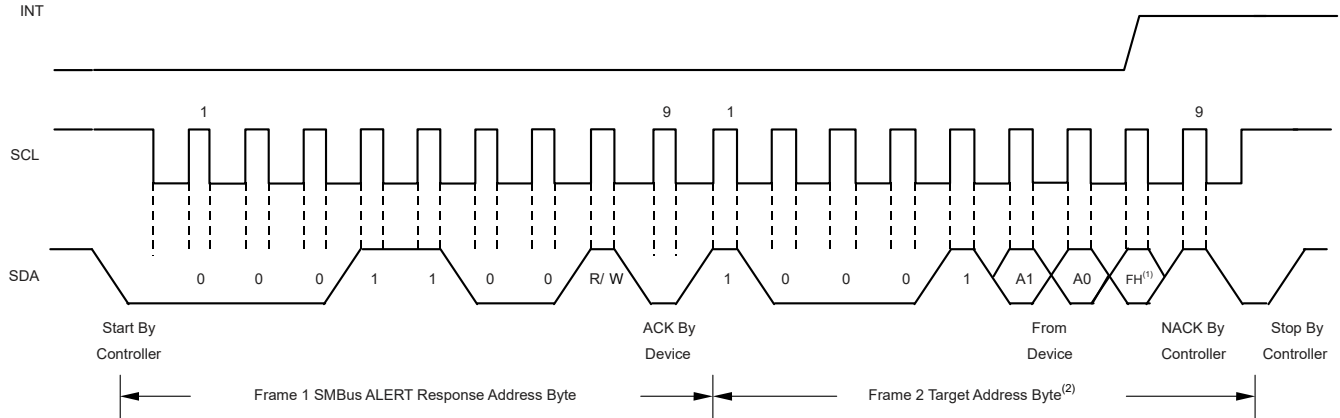

- A. FH is the [FLAG_H](#) register
- B. A1 and A0 are determined by the ADDR pin (only on SOT-5X3 version)

8-9. Timing Diagram for SMBus Alert Response

8.6 Register Maps

8-10. ALL Register Map

ADD	D15	D14	D13	D12	D11	D10	D9	D8	D7	D6	D5	D4	D3	D2	D1	D0
00h	EXPONENT				RESULT_MSB											
01h	RESULT_LSB						COUNTER				CRC					
02h	EXPONENT_FIFO0				RESULT_MSB_FIFO0											
03h	RESULT_LSB_FIFO0						COUNTER_FIFO0				CRC_FIFO0					
04h	EXPONENT_FIFO1				RESULT_MSB_FIFO1											
05h	RESULT_LSB_FIFO1						COUNTER_FIFO1				CRC_FIFO1					
06h	EXPONENT_FIFO2				RESULT_MSB_FIFO2											
07h	RESULT_LSB_FIFO2						COUNTER_FIFO2				CRC_FIFO2					
08h	THRESHOLD_L_EXPONENT				THRESHOLD_L_RESULT											
09h	THRESHOLD_H_EXPONENT				THRESHOLD_H_RESULT											
0Ah	QWAKE	0	RANGE				CONVERSION_TIME				OPERATING_MODE		LATCH	INT_POL	FAULT_COUNT	
0Bh	1024						INT_DIR		INT_CFG		0	I2C_BURST				
0Ch	0						OVERLOAD_FLAG		CONVERSION_READY_FLAG		FLAG_H	FLAG_L				
11h	0		DIDL		DIDH											

8.6.1 ALL Register Map

8.6.1.1 Register 0h (offset = 0h) [reset = 0h]

8-11. Register 0h

15	14	13	12	11	10	9	8
EXPONENT				RESULT_MSB			
R-0h				R-0h			
7	6	5	4	3	2	1	0
RESULT_MSB							
R-0h							

LEGEND: R/W = Read/Write; W = Write only; -n = value after reset

8-12. Register 00 Field Descriptions

Bit	Field	Type	Reset	Description
15-12	EXPONENT	R	0h	EXPONENT output. Determines the full-scale range of the light measurement. Used as a scaling factor for lux calculation
11-0	RESULT_MSB	R	0h	Result register MSB (Most significant bits). Used to calculate the MANTISSA representing light level within a given EXPONENT or full-scale range

8.6.1.2 Register 1h (offset = 1h) [reset = 0h]

8-13. Register 1h

15	14	13	12	11	10	9	8
RESULT_LSB							
R-0h							
7	6	5	4	3	2	1	0
COUNTER				CRC			
R-0h				R-0h			

LEGEND: R/W = Read/Write; W = Write only; -n = value after reset

8-14. Register 01 Field Descriptions

Bit	Field	Type	Reset	Description
15-8	RESULT_LSB	R	0h	Result register LSB(Least significant bits). Used to calculate MANTISSA representing light level within a given EXPONENT or full-scale range
7-4	COUNTER	R	0h	Sample counter. Rolling counter which increments for every conversion
3-0	CRC	R	0h	CRC bits. $R[19:0] = \text{MANTISSA} = ((\text{RESULT_MSB} \ll 8) + \text{RESULT_LSB})$ $X[0] = \text{XOR}(E[3:0], R[19:0], C[3:0])$ XOR of all bits $X[1] = \text{XOR}(C[1], C[3], R[1], R[3], R[5], R[7], R[9], R[11], R[13], R[15], R[17], R[19], E[1], E[3])$ $X[2] = \text{XOR}(C[3], R[3], R[7], R[11], R[15], R[19], E[3])$ $X[3] = \text{XOR}(R[3], R[11], R[19])$

8.6.1.3 Register 2h (offset = 2h) [reset = 0h]
8-15. Register 2h

15	14	13	12	11	10	9	8
EXPONENT_FIFO0				RESULT_MSB_FIFO0			
R-0h				R-0h			
7	6	5	4	3	2	1	0
RESULT_MSB_FIFO0							
R-0h							

LEGEND: R/W = Read/Write; W = Write only; -n = value after reset

8-16. Register 02 Field Descriptions

Bit	Field	Type	Reset	Description
15-12	EXPONENT_FIFO0	R	0h	EXPONENT register from FIFO 0
11-0	RESULT_MSB_FIFO0	R	0h	RESULT_MSB Register from FIFO 0

8.6.1.4 Register 3h (offset = 3h) [reset = 0h]
8-17. Register 3h

15	14	13	12	11	10	9	8
RESULT_LSB_FIFO0							
R-0h							
7	6	5	4	3	2	1	0
COUNTER_FIFO0				CRC_FIFO0			
R-0h				R-0h			

LEGEND: R/W = Read/Write; W = Write only; -n = value after reset

8-18. Register 03 Field Descriptions

Bit	Field	Type	Reset	Description
15-8	RESULT_LSB_FIFO0	R	0h	RESULT_LSB Register from FIFO 0
7-4	COUNTER_FIFO0	R	0h	COUNTER Register from FIFO 0
3-0	CRC_FIFO0	R	0h	CRC Register from FIFO 0

8.6.1.5 Register 4h (offset = 4h) [reset = 0h]
8-19. Register 4h

15	14	13	12	11	10	9	8
EXPONENT_FIFO1				RESULT_MSB_FIFO1			
R-0h				R-0h			
7	6	5	4	3	2	1	0
RESULT_MSB_FIFO1							
R-0h							

LEGEND: R/W = Read/Write; W = Write only; -n = value after reset

☒ 8-20. Register 04 Field Descriptions

Bit	Field	Type	Reset	Description
15-12	EXPONENT_FIF O1	R	0h	EXPONENT register from FIFO 1
11-0	RESULT_MSB_FI FO1	R	0h	RESULT_MSB Register from FIFO 1

8.6.1.6 Register 5h (offset = 5h) [reset = 0h]

☒ 8-21. Register 5h

15	14	13	12	11	10	9	8
RESULT_LSB_FIFO1							
R-0h							
7	6	5	4	3	2	1	0
COUNTER_FIFO1				CRC_FIFO1			
R-0h				R-0h			

LEGEND: R/W = Read/Write; W = Write only; -n = value after reset

☒ 8-22. Register 05 Field Descriptions

Bit	Field	Type	Reset	Description
15-8	RESULT_LSB_FI FO1	R	0h	RESULT_LSB Register from FIFO 1
7-4	COUNTER_FIFO 1	R	0h	COUNTER Register from FIFO 1
3-0	CRC_FIFO1	R	0h	CRC Register from FIFO 1

8.6.1.7 Register 6h (offset = 6h) [reset = 0h]

☒ 8-23. Register 6h

15	14	13	12	11	10	9	8
EXPONENT_FIFO2				RESULT_MSB_FIFO2			
R-0h				R-0h			
7	6	5	4	3	2	1	0
RESULT_MSB_FIFO2							
R-0h							

LEGEND: R/W = Read/Write; W = Write only; -n = value after reset

☒ 8-24. Register 06 Field Descriptions

Bit	Field	Type	Reset	Description
15-12	EXPONENT_FIF O2	R	0h	EXPONENT register from FIFO 2
11-0	RESULT_MSB_FI FO2	R	0h	RESULT_MSB Register from FIFO 2

8.6.1.8 Register 7h (offset = 7h) [reset = 0h]

☒ 8-25. Register 7h

15	14	13	12	11	10	9	8
RESULT_LSB_FIFO2							

8-25. Register 7h (continued)

R-0h							
7	6	5	4	3	2	1	0
COUNTER_FIFO2				CRC_FIFO2			
R-0h				R-0h			

LEGEND: R/W = Read/Write; W = Write only; -n = value after reset

8-26. Register 07 Field Descriptions

Bit	Field	Type	Reset	Description
15-8	RESULT_LSB_FIFO2	R	0h	RESULT_LSB Register from FIFO 2
7-4	COUNTER_FIFO2	R	0h	COUNTER Register from FIFO 2
3-0	CRC_FIFO2	R	0h	CRC Register from FIFO 2

8.6.1.9 Register 8h (offset = 8h) [reset = 0h]

8-27. Register 8h

15	14	13	12	11	10	9	8
THRESHOLD_L_EXPONENT				THRESHOLD_L_RESULT			
R/W-0h				R/W-0h			
7	6	5	4	3	2	1	0
THRESHOLD_L_RESULT							
R/W-0h							

LEGEND: R/W = Read/Write; W = Write only; -n = value after reset

8-28. Register 08 Field Descriptions

Bit	Field	Type	Reset	Description
15-12	THRESHOLD_L_EXPONENT	R/W	0h	Threshold low register exponent
11-0	THRESHOLD_L_RESULT	R/W	0h	Threshold low register result

8.6.1.10 Register 9h (offset = 9h) [reset = BFFFh]

8-29. Register 9h

15	14	13	12	11	10	9	8
THRESHOLD_H_EXPONENT				THRESHOLD_H_RESULT			
R/W-Bh				R/W-Fh			
7	6	5	4	3	2	1	0
THRESHOLD_H_RESULT							
R/W-FFh							

LEGEND: R/W = Read/Write; W = Write only; -n = value after reset

8-30. Register 09 Field Descriptions

Bit	Field	Type	Reset	Description
15-12	THRESHOLD_H_EXPONENT	R/W	Bh	Threshold high register exponent

8-30. Register 09 Field Descriptions (continued)

Bit	Field	Type	Reset	Description
11-0	THRESHOLD_H_RESULT	R/W	FFFh	Threshold high register result

8.6.1.11 Register Ah (offset = Ah) [reset = 3208h]

8-31. Register Ah

15	14	13	12	11	10	9	8
QWAKE	0	RANGE			CONVERSION_TIME		
R/W-0h	R/W-0h	R/W-Ch			R/W-2h		
7	6	5	4	3	2	1	0
CONVERSION_TIME		OPERATING_MODE		LATCH	INT_POL	FAULT_COUNT	
R/W-0h		R/W-0h		R/W-1h	R/W-0h	R/W-0h	

LEGEND: R/W = Read/Write; W = Write only; -n = value after reset

8-32. Register 0A Field Descriptions

Bit	Field	Type	Reset	Description
15-15	QWAKE	R/W	0h	Quick Wake-up from Standby in one shot mode by not powering down all circuits. Applicable only in One-shot mode and helps get out of standby mode faster with penalty in power consumption compared to full standby mode.
14-14	0	R/W	0h	Must read or write 0
13-10	RANGE	R/W	Ch	Controls the full-scale light level range of the device. The format of this register is same as the EXPONENT register for all values from 0 to 8. PicoStar™ variant: 0 : 328lux 1 : 655lux 2 : 1.3klux 3 : 2.6klux 4 : 5.2klux 5 : 10.5klux 6 : 21klux 7 : 42klux 8 : 83klux 12 : Auto-Range SOT-5X3 variant: 0 : 459lux 1 : 918lux 2 : 1.8klux 3 : 3.7klux 4 : 7.3klux 5 : 14.7klux 6 : 29.4klux 7 : 58.7klux 8 : 117.4klux 12 : Auto-range

8-32. Register 0A Field Descriptions (continued)

Bit	Field	Type	Reset	Description
9-6	CONVERSION_TIME	R/W	8h	Controls the device conversion time 0 : 600us 1 : 1ms 2 : 1.8ms 3 : 3.4ms 4 : 6.5ms 5 : 12.7ms 6 : 25ms 7 : 50ms 8 : 100ms 9 : 200ms 10 : 400ms 11 : 800ms
5-4	OPERATING_MODE	R/W	0h	Controls device mode of operation 0 : Power-down 1 : Forced auto-range One-shot 2 : One-shot 3 : Continuous
3-3	LATCH	R/W	1h	Controls the functionality of the interrupt reporting mechanisms for INT pin for the threshold detection logic.
2-2	INT_POL	R/W	0h	Controls the polarity or active state of the INT pin. 0 : Active Low 1 : Active High
1-0	FAULT_COUNT	R/W	0h	Fault count register instructs the device as to how many consecutive fault events are required to trigger the threshold mechanisms: the flag high (FLAG_H) and the flag low (FLAG_L) registers. 0 : One fault Count 1 : Two Fault Counts 2 : Four Fault Counts 3 : Eight Fault Counts

8.6.1.12 Register Bh (offset = Bh) [reset = 8011h]
8-33. Register Bh

15	14	13	12	11	10	9	8
1	0	0	0	0	0	0	0
R/W-1h	R/W-0h	R/W-0h	R/W-0h	R/W-0h	R/W-0h	R/W-0h	R/W-0h
7	6	5	4	3	2	1	0
0	0	0	INT_DIR	INT_CFG		0	I2C_BURST
R/W-0h	R/W-0h	R/W-0h	R/W-1h	R/W-0h		R/W-0h	R/W-1h

LEGEND: R/W = Read/Write; W = Write only; -n = value after reset

8-34. Register 0B Field Descriptions

Bit	Field	Type	Reset	Description
15-5	1024	R/W	400h	Must read or write 1024
4-4	INT_DIR	R/W	1h	Determines the direction of the INT pin. 0 : Input 1 : Output
3-2	INT_CFG	R/W	0h	Controls the output interrupt mechanism after end of conversion 0 : SMBUS Alert 1 : INT Pin asserted after every conversion 2 : Invalid 3 : INT pin asserted after every 4 conversions (FIFO full)
1-1	0	R/W	0h	Must read or write 0

☒ 8-34. Register 0B Field Descriptions (continued)

Bit	Field	Type	Reset	Description
0-0	I2C_BURST	R/W	1h	When set, enables I2C burst mode minimizing I2C read cycles by auto incrementing read register pointer by 1 after every register read

8.6.1.13 Register Ch (offset = Ch) [reset = 0h]

☒ 8-35. Register Ch

15	14	13	12	11	10	9	8
0	0	0	0	0	0	0	0
R/W-0h	R/W-0h	R/W-0h	R/W-0h	R/W-0h	R/W-0h	R/W-0h	R/W-0h
7	6	5	4	3	2	1	0
0	0	0	0	OVERLOAD_F LAG	CONVERSION _READY_FLAG	FLAG_H	FLAG_L
R/W-0h	R/W-0h	R/W-0h	R/W-0h	R-0h	R-0h	R-0h	R-0h

LEGEND: R/W = Read/Write; W = Write only; -n = value after reset

☒ 8-36. Register 0C Field Descriptions

Bit	Field	Type	Reset	Description
15-4	0	R/W	0h	Must read or write 0
3-3	OVERLOAD_FL AG	R	0h	Indicates when an overflow condition occurs in the data conversion process, typically because the light illuminating the device exceeds the full-scale range.
2-2	CONVERSION_R EADY_FLAG	R	0h	Conversion ready flag indicates when a conversion completes. The flag is set to 1 at the end of a conversion and is cleared (set to 0) when register address 0xC is either read or written with any non-zero value 0 : Conversion in progress 1 : Conversion is complete
1-1	FLAG_H	R	0h	Flag high register identifies that the result of a conversion is measurement than a specified level of interest. FLAG_H is set to 1 when the result is larger than the level in the THRESHOLD_H_EXPONENT and THRESHOLD_H_RESULT registers for a consecutive number of measurements defined by the FAULT_COUNT register.
0-0	FLAG_L	R	0h	Flag low register identifies that the result of a measurement is smaller than a specified level of interest. FL is set to 1 when the result is smaller than the level in the THRESHOLD_LOW_EXPONENT and THRESHOLD_L_RESULT registers for a consecutive number of measurements defined by the FAULT_COUNT register.

8.6.1.14 Register 11h (offset = 11h) [reset = 121h]

☒ 8-37. Register 11h

15	14	13	12	11	10	9	8
0	0	DIDL		DIDH			
R/W-0h	R/W-0h	R-0h		R-1h			
7	6	5	4	3	2	1	0
DIDH							
R-21h							

LEGEND: R/W = Read/Write; W = Write only; -n = value after reset

8-38. Register 11 Field Descriptions

Bit	Field	Type	Reset	Description
15-14	0	R/W	0h	Must read or write 0
13-12	DIDL	R	0h	Device ID L
11-0	DIDH	R	121h	Device ID H

9 Application and Implementation

注

以下のアプリケーション情報は、TI の製品仕様に含まれるものではなく、TI ではその正確性または完全性を保証いたしません。個々の目的に対する製品の適合性については、お客様の責任で判断していただくこととなります。お客様は自身の設計実装を検証しテストすることで、システムの機能を確認する必要があります。

9.1 Application Information

Ambient light sensors are used in a wide variety of applications that require precise measurement of light as perceived by human eye, since they have a specialized filter that mimic human eye. The following sections shows crucial information about integrating OPT4001 in applications.

9.2 Typical Application

9.2.1 Electrical Interface

The electrical interface is quite simple, as illustrated in [図 9-1](#) below. Connect the OPT4001 I²C SDA and SCL pins to the same pins of an applications processor, micro controller, or other digital processor. If that digital processor requires an interrupt resulting from an event of interest from the OPT4001, then connect the INT pin to either an interrupt or general-purpose I/O pin of the processor (Only for the SOT-5X3). There are multiple uses for this INT pin, including triggering a measurement on one-shot mode, signaling the system to wake up from low-power mode, processing other tasks while waiting for an ambient light event of interest, or alerting the processor that a sample is ready to be read.. Connect pullup resistors between a power supply appropriate for digital communication and the SDA and SCL pins (because the pins have open-drain output structures). If the INT pin is used, connect a pullup resistor to the INT pin. A typical value for these pullup resistors is 10 k Ω . The resistor choice can be optimized in conjunction to the bus capacitance to balance the system speed, power, noise immunity, and other requirements.



図 9-1. Typical Application Schematic

The power supply and grounding considerations are discussed in the [セクション 9.4](#).

Although spike suppression is integrated in the SDA and SCL pin circuits, use proper layout practices to minimize the amount of coupling into the communication lines. One possible introduction of noise occurs from capacitively coupling signal edges between the two communication lines themselves. Another possible noise introduction comes from other switching noise sources present in the system, especially for long communication

lines. In noisy environments, shield communication lines to reduce the possibility of unintended noise coupling into the digital I/O lines that can be incorrectly interpreted.

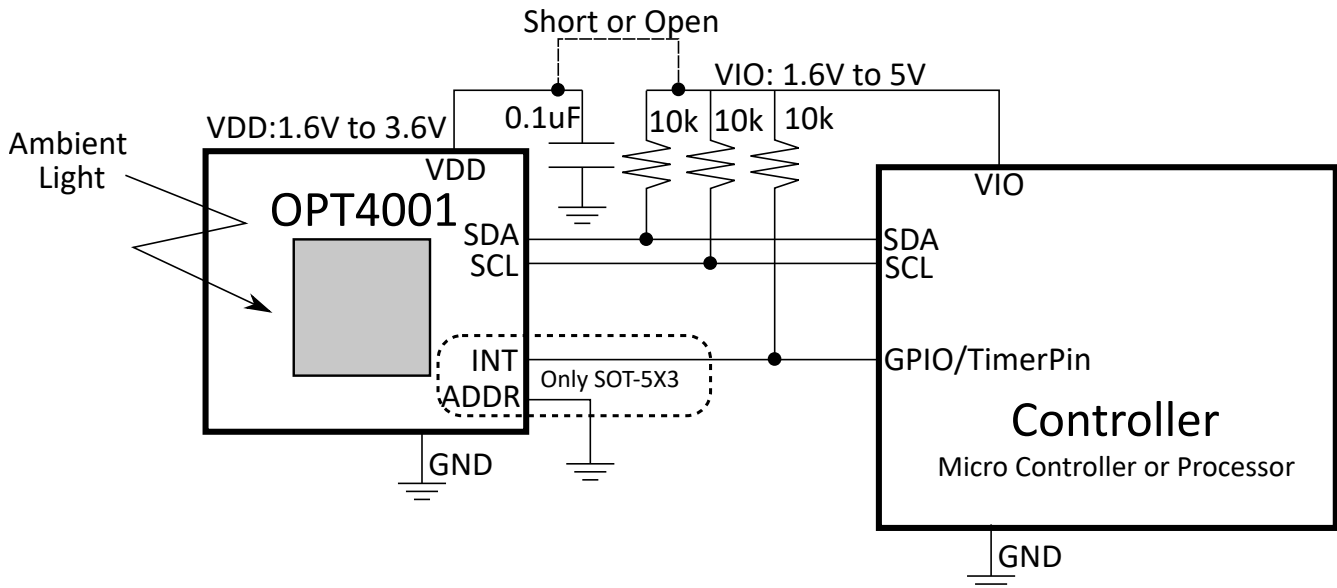
9.2.1.1 Design Requirements

9.2.1.1.1 Optical Interface

The optical interface is physically located on the same side of the device pins as the electrical interface for the PicoStar™ variant and facing away from the pins for the SOT-5X3 variant, as shown in [Figure 9-2](#) and [Figure 9-3](#)

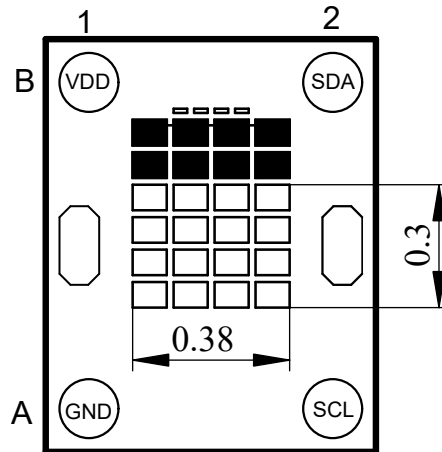

Figure 9-2. Sensor Position on PicoStar™ Variant

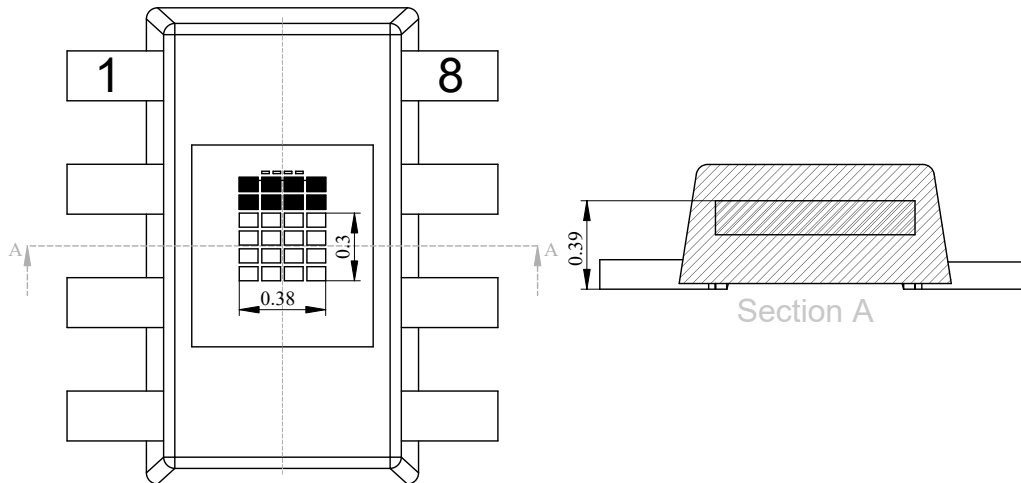

Figure 9-3. Sensor Position on the SOT-5X3 Variant

In case of the PicoStar™ variant systems, light that illuminates the sensor must come through the FPCB. Typically, the best method is to create a cutout area in the FPCB. Other methods are possible, but with associated design tradeoffs. This cutout must be carefully designed because the dimensions and tolerances impact the net-system, optical field-of-view performance. The design of this cutout is discussed more in the [Section 9.5.2](#).

Physical components, such as a plastic housing and a window that allows light from outside of the design to illuminate the sensor (see [Figure 9-4](#)), can help protect the device and neighboring circuitry. Sometimes, a dark or opaque window is used to further enhance the visual appeal of the design by hiding the sensor from view. This window material is typically transparent plastic or glass.

Generally for both package variants, any physical component that affects the light that illuminates the sensing area of a light sensor also affects the performance of that light sensor. Therefore, for the best performance,

make sure to understand and control the effect of these components. Design a window width and height to permit light from a sufficient field of view to illuminate the sensor. For best performance, use a field of view of at least $\pm 35^\circ$, or preferably $\pm 45^\circ$ or more. Understanding and designing the field of view is discussed further in application report [OPT3001: Ambient Light Sensor Application Guide](#) (SBEA002).

The visible-spectrum transmission for dark windows typically ranges between 5% to 30%, but can be less than 1%. Specify a visible-spectrum transmission as low as, but no more than, necessary to achieve sufficient visual appeal because decreased transmission decreases the available light for the sensor to measure. The windows are made dark by either applying an ink to a transparent window material, or including a dye or other optical substance within the window material itself. This attenuating transmission in the visible spectrum of the window creates a ratio between the light on the outside of the design and the light that is measured by the device. To accurately measure the light outside of the design, compensate the device measurement for this ratio.

Although the inks and dyes of dark windows serve their primary purpose of being minimally transmissive to visible light, some inks and dyes can also be very transmissive to infrared light. The use of these inks and dyes further decreases the ratio of visible to infrared light, and thus decreases sensor measurement accuracy. However, because of the excellent red and infrared rejection of the device, this effect is minimized, and good results are achieved under a dark window with similar spectral responses.

For best accuracy, avoid grill-like window structures, unless the designer understands the optical effects sufficiently. These grill-like window structures create a nonuniform illumination pattern at the sensor that make light measurement results vary with placement tolerances and angle of incidence of the light. If a grill-like structure is desired, then the device is an excellent sensor choice because the device is minimally sensitive to illumination uniformity issues disrupting the measurement process.

Light pipes can appear attractive for aiding in the optomechanical design that brings light to the sensor; however, do not use light pipes with any light sensor unless the system designer fully understands the ramifications of the optical physics of light pipes within the full context of his design and objectives.

9.2.1.2 Detailed Design Procedure

9.2.1.2.1 Optomechanical Design (PicoStar™ Variant)

After completing the electrical design and understanding optical interface, the next task is the optomechanical design of the FPCB cutout. Design this cutout in conjunction with the tolerance capabilities of the FPCB manufacturer. Or, conversely, choose the FPCB manufacturer for the capabilities of creating this cutout. A semi-rectangular shape of the cutout, created with a standard FPCB laser, is presented here. There are many alternate approaches with different cost, tolerance, and performance tradeoffs.

An image of the created FPCB with the plus shaped cutout and a rectangular shaped cutout is shown below. The plus shape is a good choice for light collection in both directions with a wider field of view. In case of the rectangular cutout shape, the long (vertical) direction of the cutout has minimal effect on the angular response because any shadows created from the FPCB do not come near the sensor. The long cutout direction defines the axis of rotation with the less restricted field of view. The narrow (horizontal) direction of the cutout, which is limited by the electrical connections to OPT4001, can create shadows that can have a minor impact on the angular response. The narrow cutout direction defines the axis of rotation of the more restricted view. The possibility of shadows are illustrated in [Figure 9-6](#), a cross-sectional diagram showing the OPT4001 device, with the sensing area, so ldered to the FPCB with the cutout. A circular cutout is more restrictive in the field of view casting shadow from all directions of light. TI recommends to take in to account the effect of shadows and impact of this on the field of view of the sensor. The product folder has application notes and tools to help understand these artifacts.

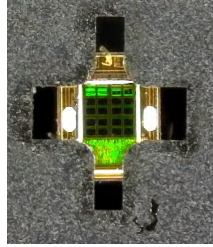

☒ 9-4. Image of FPCB With OPT4001 Mounted, Receiving Light Through the Cutout with a Plus Shape

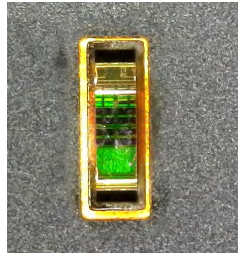

☒ 9-5. Image of FPCB With OPT4001 Mounted, Receiving Light Through the Cutout with a Rectangular Shape

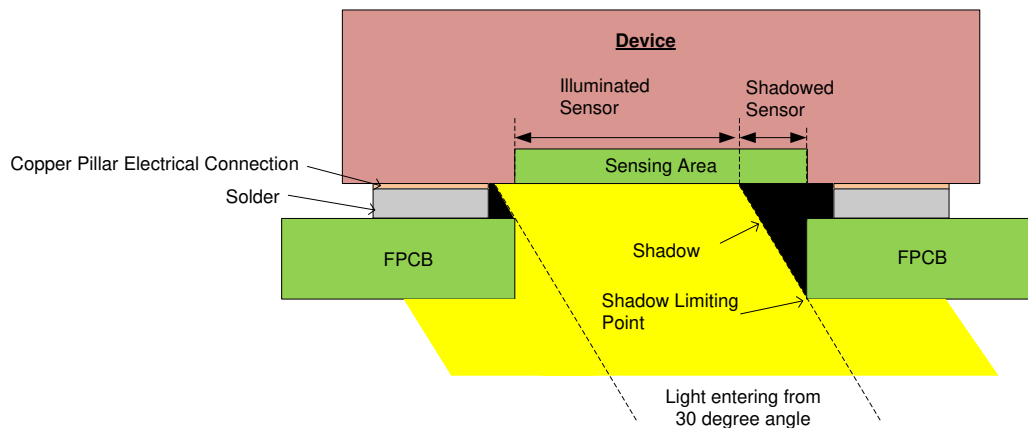



☒ 9-6. Cross-Sectional Diagram of OPT4001 Soldered to an FPCB With a Cutout, Including Light Entering From an Angle

There can be an additional need to put a product casing over the assembly of the device and the FPCB. The window sizing and placement for such an assembly is discussed in more rigorous detail in application report [OPT3001: Ambient Light Sensor Application Guide](#) (SBEA002).

9.2.1.2.2 Optomechanical Design (SOT-5X3 Variant)

After completing the electrical design, the next task is the optomechanical design. Window sizing and placement is discussed in more rigorous detail in [OPT3001: Ambient Light Sensor Application Guide](#).

9.2.1.3 Application Curves (PicoStar™ Variant)

 9-7 and  9-8 show example response curves of the device for a rectangular cut out hole as shown in  9-13. The shape of the cutout affects the overall light collection and the field of view can clearly be seen.

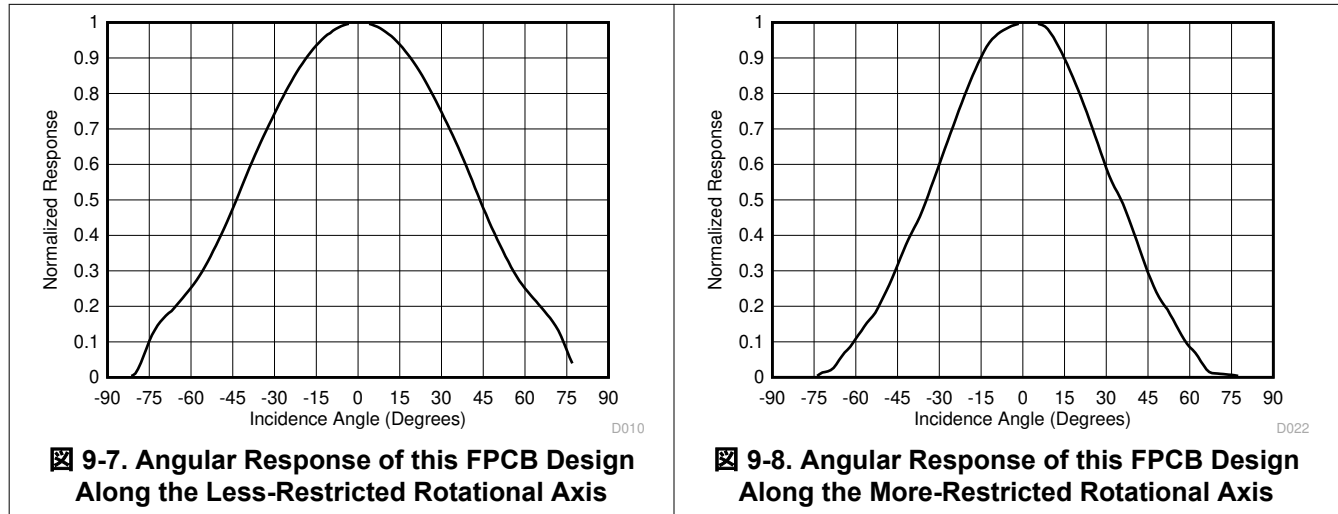

9.3 Do's and Don'ts

As with any optical product, take special care when handling the OPT4001. In case of the PicoStar™ variant, the device is a piece of active silicon, without the mechanical protection of an epoxy-like package or other reinforcement. This design allows the device to be as thin as possible. Take extra care to handle the device gently to not crack or break the device. Use a properly-sized vacuum manipulation tool to handle the device.

Generally for both package variants, the optical surface of the device must be kept clean for the best performance, both when prototyping with the device, and during mass production manufacturing procedures. Keep the optical surface clean of fingerprints, dust, and other optical-inhibiting contaminants.

If the optical surface of the device requires cleaning, then use a few gentle brushes with a soft swab of deionized water or isopropyl alcohol. Avoid potentially abrasive cleaning and manipulating tools and excessive force that can scratch the optical surface.

If the OPT4001 performs less than excellent, then inspect the optical surface for dirt, scratches, or other optical artifacts.

9.4 Power Supply Recommendations

Although the OPT4001 has low sensitivity to power-supply issues, good practices are always recommended. For best performance, the device VDD pin must have a stable, low-noise power supply with a 100-nF bypass capacitor close to the device and solid grounding. There are many options for powering the device because of the device low current consumption levels.

9.5 Layout

9.5.1 Layout Guidelines

Before understanding the layout requirement for OPT4001, understanding the placement on the PCB is critical.

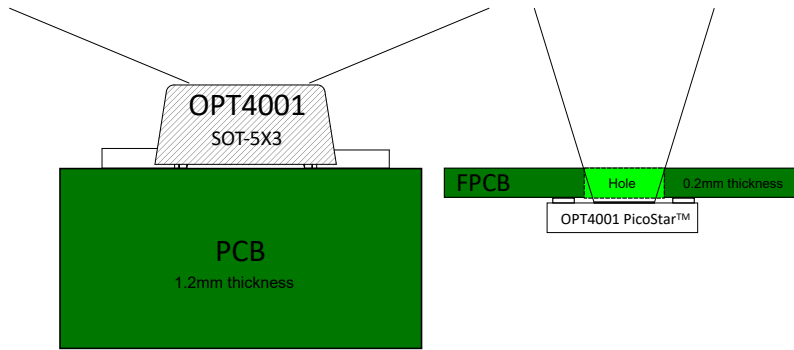

☒ 9-9. Placement Side View of Packages

In case of the SOT-5X3 package variant the device, since the lighting sensitive area and the device pins are on opposite sides of each other, a conventional placement on the PCB makes sure of good light collection. In case of the PicoStar™ variant of the device, since the light sensitive area and the device pins are on the same side, special arrangement as shown in the figure is required to achieve good light collection. Typically a thin flexible PCB with a hole or a cutout centered around the optical area is required for wide angle light collection for the PicoStar™ variant. A regular PCB can be used but the amount of light collected and the field of view of light collection are not very good and generally not recommended. Cut out for the light collection can be of any shape with large enough opening to let ample light fall on the light sensitive area. ☒ 9-12 and ☒ 9-13 show examples of two such shapes which help maximize light collection. A circular cut out as much larger as the manufacturing allows is also acceptable but can restrict the field of view and reduce the light collection. Tools and documentation are available on TI product folder to estimate the field of view based on the hole size.

Placing the decoupling capacitor close to the device is highly recommended at the same time, note that optically reflective surfaces of components also affect the performance of the design. The three-dimensional geometry of all components and structures around the sensor must be taken into consideration to prevent unexpected results from secondary optical reflections. Placing capacitors and components at a distance of at least twice the height of the component is usually sufficient. The best optical layout is to place all close components on the opposite side of the PCB from the OPT4001. However, this approach is not be practical for the constraints of every design.

The device layout is also critical for good SMT assembly. Two types of land pattern pads can be used for this package: solder mask defined pads (SMD) and non-solder mask defined pads (NSMD). SMD pads have a solder mask opening that is smaller than the metal pads, whereas NSMD has a solder mask opening that is larger than the metal pad. ☒ 9-10 illustrates these types of landing-pattern pads. SMD is preferred because SMD provides a more accurate soldering-pad dimension with the trace connections. For further discussion of SMT and PCB recommendations, see the [Soldering and Handling Recommendations](#).

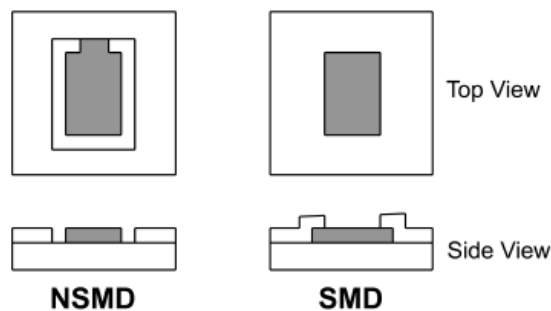

☒ 9-10. Soldermask Defined Pad (SMD) and Non-Soldermask Defined Pad (NSMD)

9.5.2.1 Soldering and Handling Recommendations (SOT-5X3 Variant)

The OPT4001 has been qualified for three soldering reflow operations per JEDEC JSTD-020.

Note that excessive heat can discolor the device and affect optical performance.

See application report [SLUA271, QFN/SON PCB Attachment](#), for details on soldering thermal profile and other information. If the OPT4001 must be removed from a PCB, discard the device and do not reattach.

As with most optical devices, handle the device with special care to make sure that optical surfaces stay clean and free from damage. See [セクション 9.3](#) for more detailed recommendations. For best optical performance, solder flux and any other possible debris must be cleaned after soldering processes.



注

The bottom side of the device features an angled feature to denote the PIN 1

☒ 9-14. Identification Feature for PIN 1

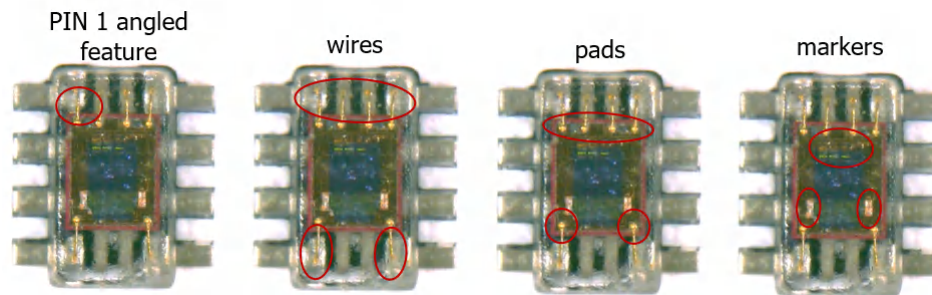

☒ 9-15. Identification Features for PIN 1 on Package

9.5.2.2 Soldering and Handling Recommendations (PicoStar™ Variant)

The OPT4001 is a small device with special soldering and handling considerations. See [セクション 9.2.1.2.1](#) for implications of alignment between the device and the cutout area. See [セクション 9.5.1](#) for considerations of the soldering pads.

If the OPT4001 must be removed from a PCB, discard the device and do not reattach.

Note that excessive heat can discolor the device and affect optical performance.

As with most optical devices, handle the OPT4001 with special care to make sure that optical surfaces stay clean and free from damage. See [セクション 9.3](#) for more detailed recommendations. For best optical performance, solder flux and any other possible debris must be cleaned after soldering processes.

9.5.2.2.1 Solder Paste

For solder-paste deposition, use a stencil-printing process that involves the transfer of solder paste through predefined apertures with the application of pressure. Stencil parameters, such as aperture area ratio and fabrication process, have a significant impact on paste deposition. Cut the stencil apertures using a laser with an electropolish-fabrication method. Taper the stencil aperture walls by 5° to facilitate paste release. Shifting the

solder-paste towards the outside of the device minimizes the possibility of solder getting into the device sensing area. See the mechanical packages attached to the end of this data sheet.

Use solder paste selection type 4 or higher, no-clean, lead-free solder paste. If solder splatters in the reflow process, choose a solder paste with normal- or low-flux contents, or alter the reflow profile per the [セクション 9.5.2.2.3](#).

9.5.2.2.2 Package Placement

Use a pick-and-place nozzle with a size number larger than 0.6 mm. If the placement method is done by programming the component thickness, then add 0.04 mm to the actual component thickness so that the package sits halfway into the solder paste. If placement is by force, then choose minimum force no larger than 3N to avoid forcing out solder paste, or free falling the package, and to avoid soldering problems such as bridging and solder balling.

9.5.2.2.3 Reflow Profile

Use the profile in [図 9-16](#), and adjust if necessary. Use a slow solder reflow ramp rate of 1°C to 1.2°C/s to minimize chances of solder splattering onto the sensing area.



图 9-16. Recommended Solder Reflow Temperature Profile

9.5.2.2.4 Special Flexible Printed-Circuit Board (FPCB) Recommendations

Special flexible printed-circuit board (FPCB) design recommendations include:

- Fabricate per IPC-6013.
- Use material of flexible copper clad per IPC 4204/11 (Define polyimide and copper thickness per product application).
- Finish: All exposed copper are electroless Ni immersion gold (ENIG) per IPC 4556.
- Solder mask per IPC SM840.
- Use a laser to create the cutout for light sensing for better accuracy, and to avoid affecting the soldering pad dimension. Other options, such as punched cutouts, are possible. See the [セクション 9.2.1.2.1](#) for further discussion ranging from the implications of the device to cutout region size and alignment. The full design must be considered, including the tolerances.

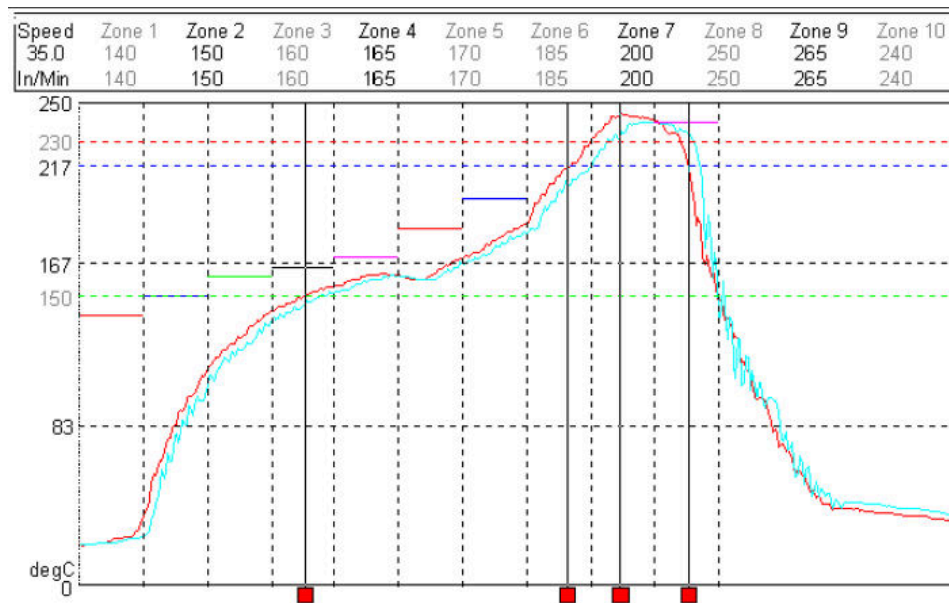
To assist the handling of the very thin flexible circuit, design and fabricate a fixture to hold the flexible circuit through the paste-printing, pick-and-place, and reflow processes. Contact the factory for examples of such fixtures.

9.5.2.2.5 Rework Process

If the device must be removed from a PCB, discard the device and do not reattach. To remove the package from the PCB/Flexi cable, heat the solder joints above liquidus temperature. Bake the board at 125°C for 4 hours prior to rework to remove moisture that may crack the PCB or causing delamination. Use a thermal heating profile to remove a package that is close to the profile that mounts the package. Clean the site to remove any excess solder and residue to prepare for installing a new package. Use a mini stencil (localized stencil) to apply solder paste to the land pattern. In case a mini stencil cannot be used because of spacing or other reasons, apply solder paste on the package pads directly, then mount, and reflow.

10 Device and Documentation Support

10.1 Documentation Support

10.1.1 Related Documentation

For related documentation see the following:

- [OPT3001: Ambient Light Sensor Application Guide](#) (SBEA002)
- [OPT4001EVM User's Guide](#) (SBOU278)
- [QFN/SON PCB Attachment Application Report](#) (SLUA271)

10.2 ドキュメントの更新通知を受け取る方法

ドキュメントの更新についての通知を受け取るには、[ti.com](https://www.ti.com) のデバイス製品フォルダを開いてください。「更新の通知を受け取る」をクリックして登録すると、変更されたすべての製品情報に関するダイジェストを毎週受け取れます。変更の詳細については、修正されたドキュメントに含まれている改訂履歴をご覧ください。

10.3 サポート・リソース

[TI E2E™ サポート・フォーラム](#)は、エンジニアが検証済みの回答と設計に関するヒントをエキスパートから迅速かつ直接得ることができる場所です。既存の回答を検索したり、独自の質問をしたりすることで、設計に必要な支援を迅速に得ることができます。

リンクされているコンテンツは、該当する貢献者により、現状のまま提供されるものです。これらは TI の仕様を構成するものではなく、必ずしも TI の見解を反映したものではありません。TI の[使用条件](#)を参照してください。

10.4 Trademarks

PicoStar™, Picostar™, and TI E2E™ are trademarks of Texas Instruments.

すべての商標は、それぞれの所有者に帰属します。

10.5 静電気放電に関する注意事項



この IC は、ESD によって破損する可能性があります。テキサス・インスツルメンツは、IC を取り扱う際には常に適切な注意を払うことを推奨します。正しい取り扱いおよび設置手順に従わない場合、デバイスを破損するおそれがあります。

ESD による破損は、わずかな性能低下からデバイスの完全な故障まで多岐にわたります。精密な IC の場合、パラメータがわずかに変化するだけで公表されている仕様から外れる可能性があるため、破損が発生しやすくなっています。

10.6 用語集

[テキサス・インスツルメンツ用語集](#) この用語集には、用語や略語の一覧および定義が記載されています。

11 Mechanical, Packaging, and Orderable Information

The following pages include mechanical, packaging, and orderable information. This information is the most current data available for the designated devices. This data is subject to change without notice and revision of this document. For browser-based versions of this data sheet, refer to the left-hand navigation.

PACKAGING INFORMATION

Orderable part number	Status (1)	Material type (2)	Package Pins	Package qty Carrier	RoHS (3)	Lead finish/ Ball material (4)	MSL rating/ Peak reflow (5)	Op temp (°C)	Part marking (6)
OPT4001DTSR	Active	Production	SOT-5X3 (DTS) 8	3000 LARGE T&R	Yes	NIPDAU	Level-2-260C-1 YEAR	-40 to 85	4001
OPT4001DTSR.A	Active	Production	SOT-5X3 (DTS) 8	3000 LARGE T&R	Yes	NIPDAU	Level-2-260C-1 YEAR	-40 to 85	4001
OPT4001DTST	Obsolete	Production	SOT-5X3 (DTS) 8	-	-	Call TI	Call TI	-40 to 85	4001
OPT4001YMNR	Active	Production	PICOSTAR (YMN) 4	3000 LARGE T&R	Yes	SNAGCU	Level-1-260C-UNLIM	-40 to 85	01
OPT4001YMNR.A	Active	Production	PICOSTAR (YMN) 4	3000 LARGE T&R	Yes	SNAGCU	Level-1-260C-UNLIM	-40 to 85	01
OPT4001YMNT	Obsolete	Production	PICOSTAR (YMN) 4	-	-	Call TI	Call TI	-40 to 85	01

(1) **Status:** For more details on status, see our [product life cycle](#).

(2) **Material type:** When designated, preproduction parts are prototypes/experimental devices, and are not yet approved or released for full production. Testing and final process, including without limitation quality assurance, reliability performance testing, and/or process qualification, may not yet be complete, and this item is subject to further changes or possible discontinuation. If available for ordering, purchases will be subject to an additional waiver at checkout, and are intended for early internal evaluation purposes only. These items are sold without warranties of any kind.

(3) **RoHS values:** Yes, No, RoHS Exempt. See the [TI RoHS Statement](#) for additional information and value definition.

(4) **Lead finish/Ball material:** Parts may have multiple material finish options. Finish options are separated by a vertical ruled line. Lead finish/Ball material values may wrap to two lines if the finish value exceeds the maximum column width.

(5) **MSL rating/Peak reflow:** The moisture sensitivity level ratings and peak solder (reflow) temperatures. In the event that a part has multiple moisture sensitivity ratings, only the lowest level per JEDEC standards is shown. Refer to the shipping label for the actual reflow temperature that will be used to mount the part to the printed circuit board.

(6) **Part marking:** There may be an additional marking, which relates to the logo, the lot trace code information, or the environmental category of the part.

Multiple part markings will be inside parentheses. Only one part marking contained in parentheses and separated by a "~" will appear on a part. If a line is indented then it is a continuation of the previous line and the two combined represent the entire part marking for that device.

Important Information and Disclaimer:The information provided on this page represents TI's knowledge and belief as of the date that it is provided. TI bases its knowledge and belief on information provided by third parties, and makes no representation or warranty as to the accuracy of such information. Efforts are underway to better integrate information from third parties. TI has taken and continues to take reasonable steps to provide representative and accurate information but may not have conducted destructive testing or chemical analysis on incoming materials and chemicals. TI and TI suppliers consider certain information to be proprietary, and thus CAS numbers and other limited information may not be available for release.

In no event shall TI's liability arising out of such information exceed the total purchase price of the TI part(s) at issue in this document sold by TI to Customer on an annual basis.

OTHER QUALIFIED VERSIONS OF OPT4001 :

- Automotive : [OPT4001-Q1](#)

NOTE: Qualified Version Definitions:

- Automotive - Q100 devices qualified for high-reliability automotive applications targeting zero defects

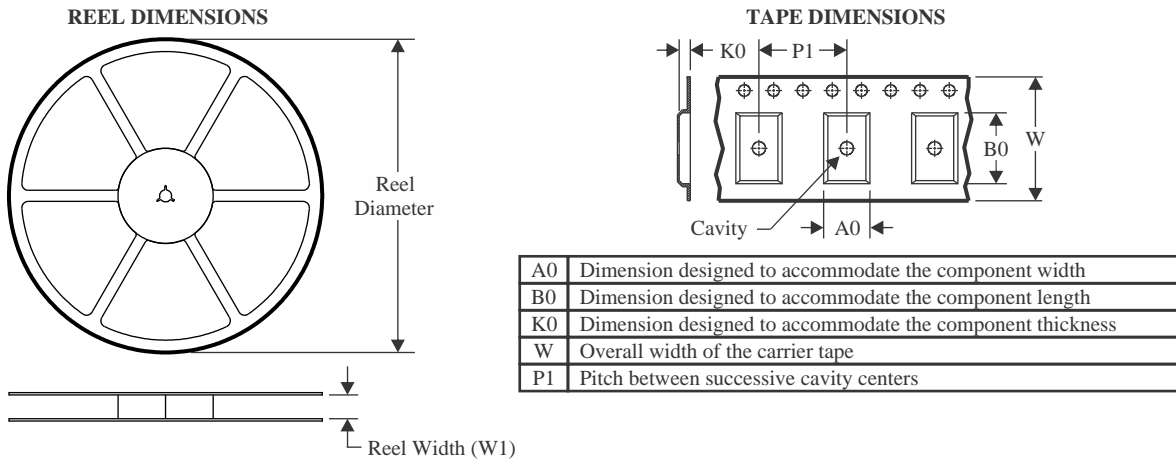
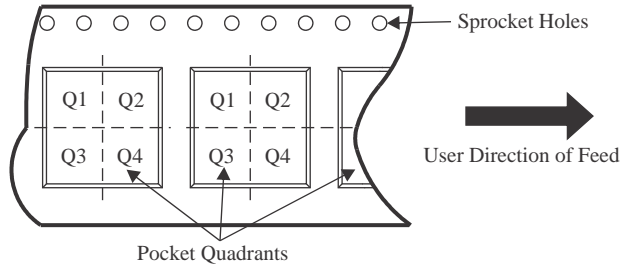
TAPE AND REEL INFORMATION

QUADRANT ASSIGNMENTS FOR PIN 1 ORIENTATION IN TAPE

*All dimensions are nominal

Device	Package Type	Package Drawing	Pins	SPQ	Reel Diameter (mm)	Reel Width W1 (mm)	A0 (mm)	B0 (mm)	K0 (mm)	P1 (mm)	W (mm)	Pin1 Quadrant
OPT4001YMNR	PICOSTAR	YMN	4	3000	180.0	8.4	0.94	1.15	0.37	2.0	8.0	Q1

TAPE AND REEL BOX DIMENSIONS

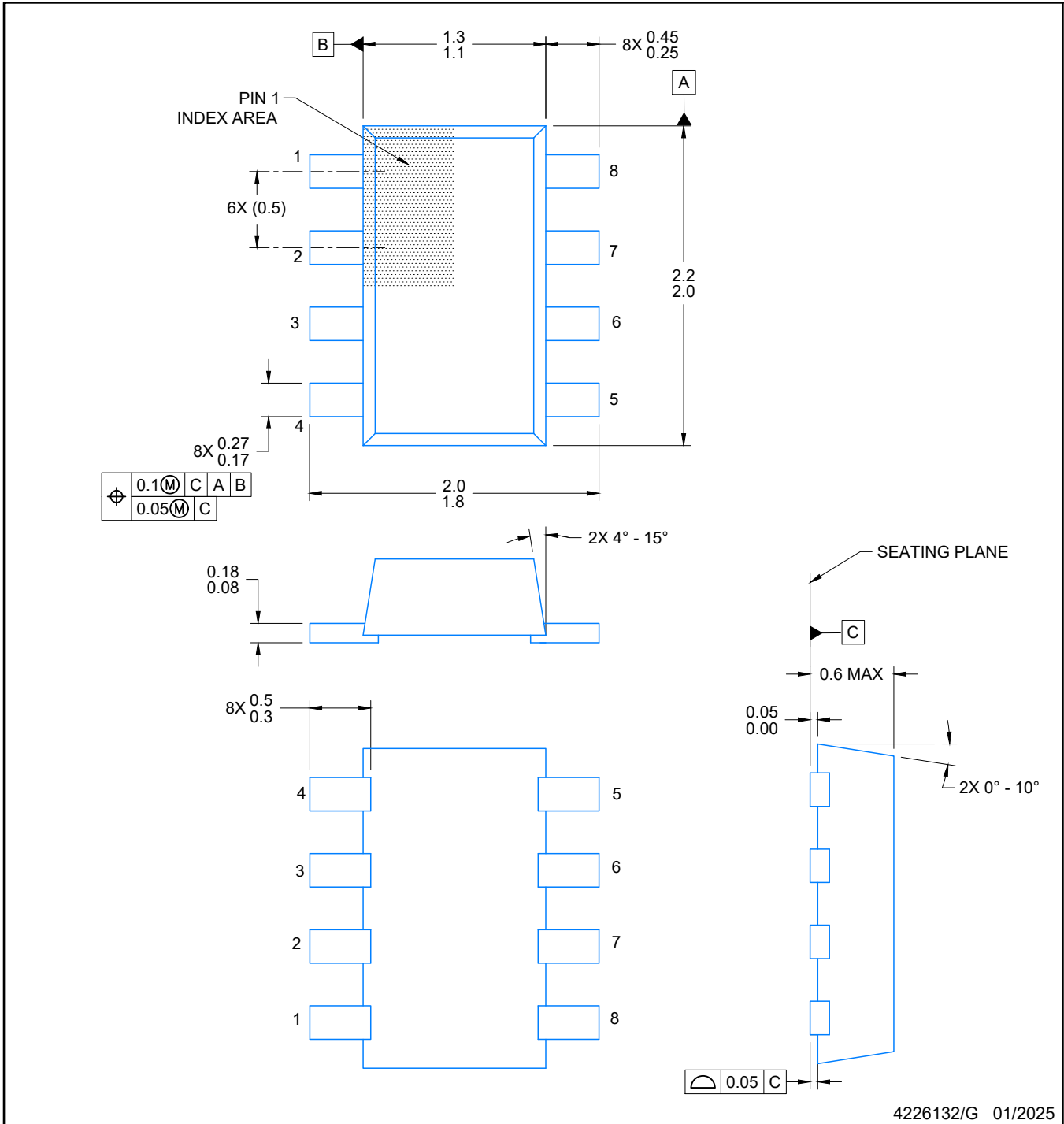

*All dimensions are nominal

Device	Package Type	Package Drawing	Pins	SPQ	Length (mm)	Width (mm)	Height (mm)
OPT4001YMNR	PICOSTAR	YMN	4	3000	182.0	182.0	20.0

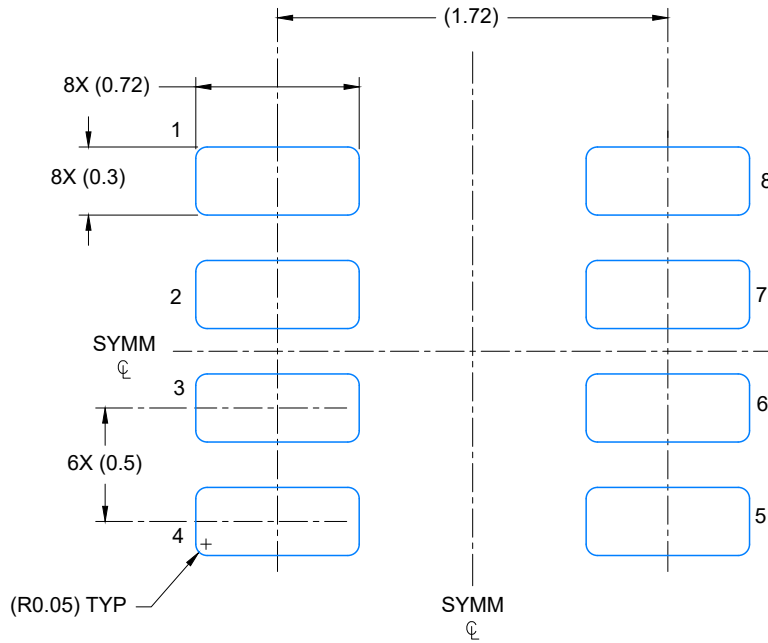

NOTES:

1. All linear dimensions are in millimeters. Any dimensions in parenthesis are for reference only. Dimensioning and tolerancing per ASME Y14.5M.
2. This drawing is subject to change without notice.
3. Body dimensions do not include mold flash, protrusions or gate burrs. Mold flash, interlead flash, protrusions or gate burrs shall not exceed 0.171 per end or side.
4. The side flash along with the stub lead is allowed.
5. Any detached side flash from the stub lead is allowed unless it is touching the bottom side of the lead.



LAND PATTERN EXAMPLE
EXPOSED METAL SHOWN
SCALE: 30X

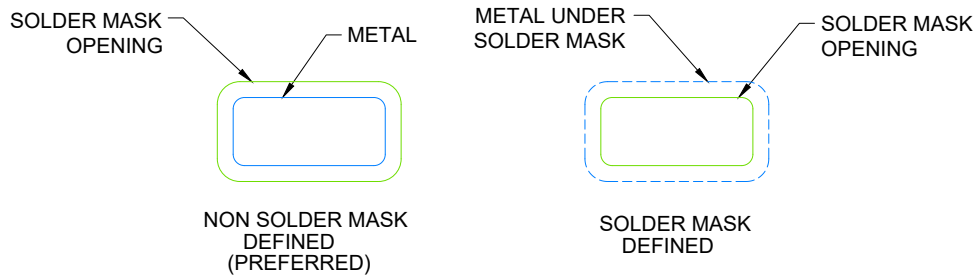

SOLDER MASK DETAILS

4226132/G 01/2025

NOTES: (continued)

- 6. Publication IPC-7351 may have alternate designs.
- 7. Solder mask tolerances between and around signal pads can vary based on board fabrication site.
- 8. Land pad design aligns to IPC-610, Bottom Termination Component (BTC) solder joint inspection criteria.

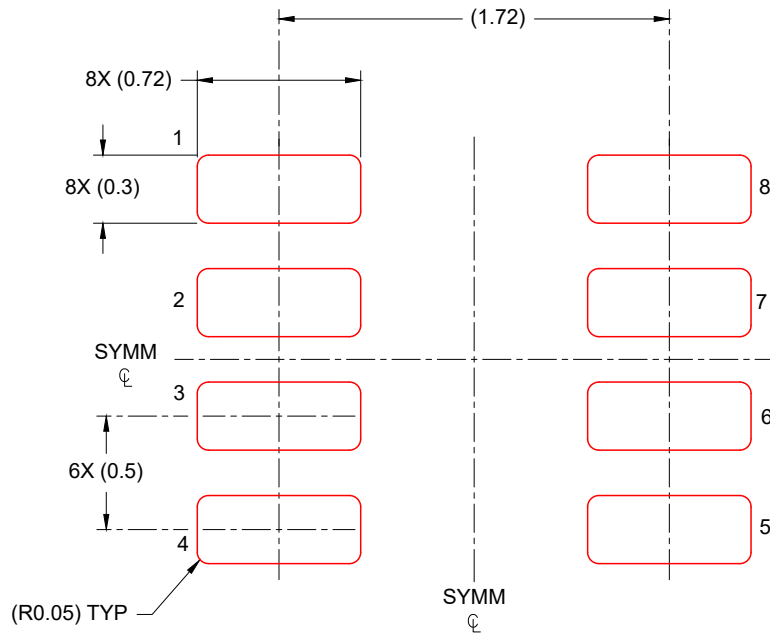

SOLDER PASTE EXAMPLE
BASED ON 0.125 mm THICK STENCIL
SCALE: 30X

4226132/G 01/2025

NOTES: (continued)

- 9. Laser cutting apertures with trapezoidal walls and rounded corners may offer better paste release. IPC-7525 may have alternate design recommendations.
- 10. Board assembly site may have different recommendations for stencil design.

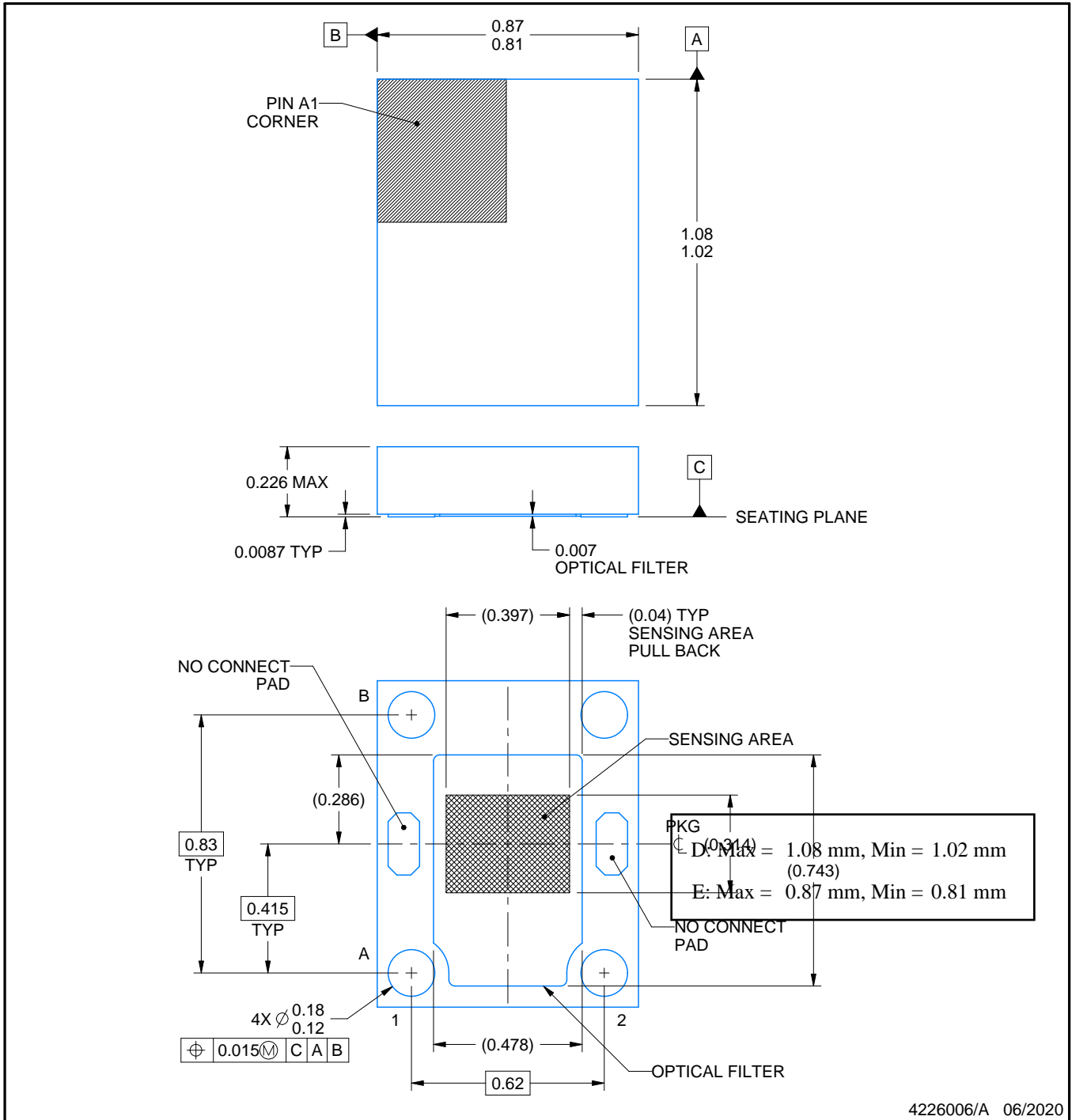
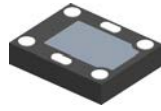

NOTES:

PicoStar is a trademark of Texas Instruments.

1. All linear dimensions are in millimeters. Any dimensions in parenthesis are for reference only. Dimensioning and tolerancing per ASME Y14.5M.
2. This drawing is subject to change without notice.

EXAMPLE BOARD LAYOUT

YMN0004A

PicoStar™ - 0.226 mm max height

PicoStar

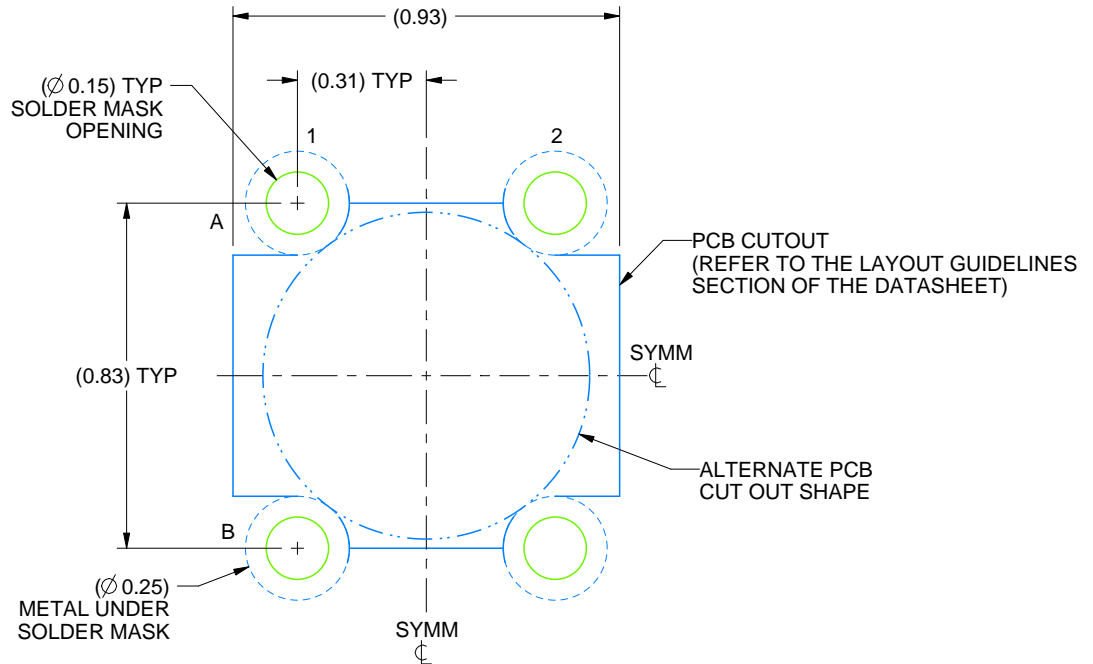

LAND PATTERN EXAMPLE
SCALE: 55X

4226006/A 06/2020

NOTES: (continued)

- Final dimensions may vary due to manufacturing tolerance considerations and also routing constraints. For more information, see Texas Instruments literature number SLUA271 (www.ti.com/lit/slua271).

EXAMPLE STENCIL DESIGN

YMN0004A

PicoStar™ - 0.226 mm max height

PicoStar

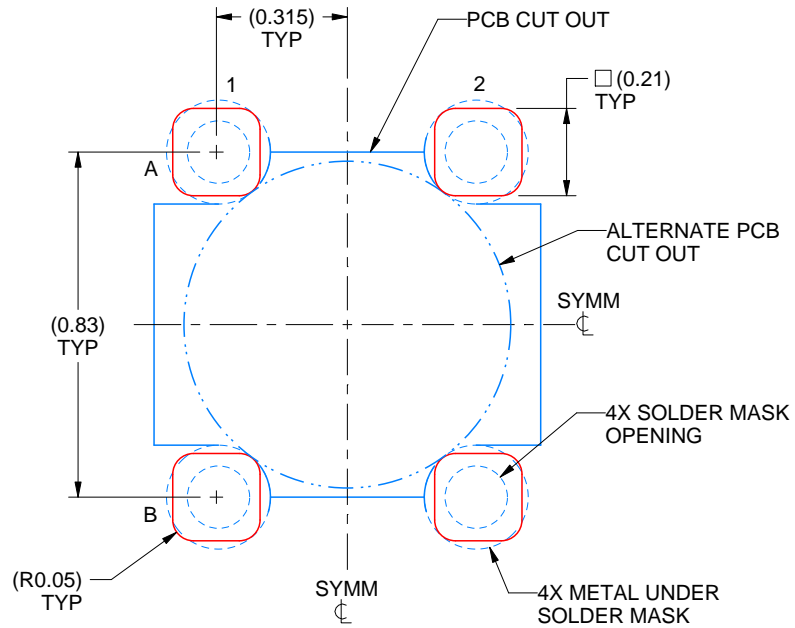

SOLDER PASTE EXAMPLE
BASED on 0.075 mm THICK STENCIL
SCALE: 55X

4226006/A 06/2020

NOTES: (continued)

4. Laser cutting apertures with trapezoidal walls and rounded corners may offer better paste release.

重要なお知らせと免責事項

TI は、技術データと信頼性データ (データシートを含みます)、設計リソース (リファレンス デザインを含みます)、アプリケーションや設計に関する各種アドバイス、Web ツール、安全性情報、その他のリソースを、欠陥が存在する可能性のある「現状のまま」提供しており、商品性および特定目的に対する適合性の黙示保証、第三者の知的財産権の非侵害保証を含むいかなる保証も、明示的または黙示的にかかわらず拒否します。

これらのリソースは、TI 製品を使用する設計の経験を積んだ開発者への提供を意図したものです。(1) お客様のアプリケーションに適した TI 製品の選定、(2) お客様のアプリケーションの設計、検証、試験、(3) お客様のアプリケーションに該当する各種規格や、その他のあらゆる安全性、セキュリティ、規制、または他の要件への確実な適合に関する責任を、お客様のみが単独で負うものとし、

上記の各種リソースは、予告なく変更される可能性があります。これらのリソースは、リソースで説明されている TI 製品を使用するアプリケーションの開発の目的でのみ、TI はその使用をお客様に許諾します。これらのリソースに関して、他の目的で複製することや掲載することは禁止されています。TI や第三者の知的財産権のライセンスが付与されている訳ではありません。お客様は、これらのリソースを自身で使用した結果発生するあらゆる申し立て、損害、費用、損失、責任について、TI およびその代理人を完全に補償するものとし、TI は一切の責任を拒否します。

TI の製品は、[TI の販売条件](#)、[TI の総合的な品質ガイドライン](#)、[ti.com](#) または TI 製品などに関連して提供される他の適用条件に従い提供されます。TI がこれらのリソースを提供することは、適用される TI の保証または他の保証の放棄の拡大や変更を意味するものではありません。TI がカスタム、またはカスタマー仕様として明示的に指定していない限り、TI の製品は標準的なカタログに掲載される汎用機器です。

お客様がいかなる追加条項または代替条項を提案する場合も、TI はそれらに異議を唱え、拒否します。

Copyright © 2026, Texas Instruments Incorporated

最終更新日 : 2025 年 10 月