

# OPT4041 高速、デュアルチャンネル、高精度、デジタル周辺光センサ

## 1 特長

- High speed I<sup>2</sup>C インターフェイスを使用した高精度の高速光 / デジタル変換
- 可視チャンネル:
  - 優れた近赤外線 (IR) 除去機能により人間の目によく合致した高精度の光フィルタリングを実現
  - 28 ビットでの実効ダイナミックレンジ: 585 $\mu$ lux $\sim$ 157klux
- 広帯域チャンネル:
  - NIR を含む広範囲の波長に応答可能
  - 26 ビットでの実効ダイナミックレンジ: 192.3pW/cm<sup>2</sup> $\sim$ 12.91mW/cm<sup>2</sup>
- 片対数出力:
  - 9 (可視チャンネル) および 7 (WB チャンネル) のバイナリ対数フルスケール光レンジ
  - 各範囲内で非常に線形的な応答
- 内蔵の自動フルスケール光レンジ選択ロジックにより、入力光条件に基づいて測定レンジを切り替え、常に可能な限り最高の分解能を実現
- 12 ステップの構成可能な変換時間:
  - チャンネルあたり 600 $\mu$ s $\sim$ 800ms (高速、高精度アプリケーションに対応可能)
- ハードウェア同期トリガおよび割り込み用の外部ピン割り込み
- I<sup>2</sup>C バースト読み出し可能な出力レジスタの内部 FIFO
- 小さい動作電流: 30 $\mu$ A
- 超低消費電力スタンバイ時: 2 $\mu$ A
- 動作温度範囲: -40 $^{\circ}$ C $\sim$ +85 $^{\circ}$ C
- 広い電源電圧範囲: 1.6V $\sim$ 3.6V
- 5.5V 許容の I/O ピン
- I<sup>2</sup>C アドレスを選択可能
- 小さい外形:
  - 2.1mm  $\times$  1.9mm  $\times$  0.6mm SOT-5X3 パッケージ

## 2 アプリケーション

- IP ネットワーク カメラ
- ビデオドアベル
- アナログ セキュリティ カメラ
- ドア センサと窓センサ

### パッケージ情報

| 部品番号    | パッケージ (1)   | パッケージ サイズ(2)                        |
|---------|-------------|-------------------------------------|
| OPT4041 | SOT-5X3 (8) | 2.1mm $\times$ 1.9mm $\times$ 0.6mm |

- (1) 詳細については、[セクション 11](#) を参照してください。
- (2) パッケージ サイズ (長さ  $\times$  幅) は公称値で、該当する場合はピンも含まれます。

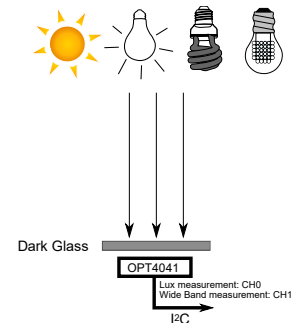

### OPT4041 の代表的なアプリケーション図

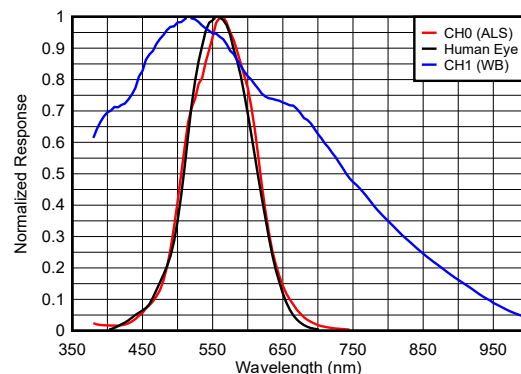

### スペクトル応答 : OPT4041 と人間の目の比較



### 3 概要

OPT4041 は、2 つの独立したチャンネルで可視光の強度を測定する光 / デジタル センサ (シングル チップのルクス メーター) です。ALS チャンネルのスペクトル応答は人間の目の明所視応答によく合致します。一方、WB チャンネルのスペクトル応答は幅が広く、広範囲の光スペクトルを測定します。ALS チャンネルは特別に設計されたフィルタにより、一般的な光源から近赤外線成分を除去し、正確な光の強度を測定します。OPT4041 の出力は片対数で、バイナリ対数フルスケール光レンジと、各レンジ内での非常に線形な応答を備えています。可視チャンネルには 9 つのバイナリ光レンジがあり、585 $\mu$ lux $\sim$ 157klux の測定能力と 28 ビットの実効ダイナミックレンジを実現します。広帯域チャンネルには 7 つの光レンジがあり、192.3pW/cm<sup>2</sup> $\sim$ 12.91mW/cm<sup>2</sup> の測定能力と 26 ビットの実効ダイナミックレンジを実現します。内蔵の自動レンジ選択ロジックにより、光レベルに基づいてデバイスのゲイン設定が動的に調整されるため、ユーザーの入力なしであらゆる条件下で可能な限り最高の分解能が得られます。

OPT4041 は、両方のチャンネルに工学的光学フィルタを搭載しており、強力な帯域外除去を実現します。可視チャンネルに強力な赤外線除去機能があるため、特に審美的な理由でセンサを暗色のガラス下に配置した場合に、あらゆる光源にわたって高いルクス精度を維持できます。WB チャンネルはスペクトル応答の範囲が広く、850nm および 940nm の NIR 波長を含む広範囲のスペクトル成分を測定できます。

OPT4041 は、ユーザーの使いやすさ向上のために光レベル検出機能を必要とするシステム向けに設計されており、通常、人間の目との一致度が低く近赤外線除去機能が劣る低精度のフォトダイオード、フォトレジスタ、その他の周辺光センサの代替品として利用できます。

OPT4041 デバイスは、12 ステップでチャンネル当たり 600 $\mu$ s $\sim$ 800ms の光変換時間で動作するように設定でき、アプリケーションのニーズに応じたシステムの柔軟性を実現します。変換時間には、光の積分時間とアナログ / デジタル (ADC) 変換時間が含まれます。測定の分解能は、光の強度と積分時間の組み合わせによって決定され、実質的に最小 585 $\mu$ lux までの光強度の変化を測定できます。

柔軟なデジタル動作により、システムの統合が可能です。連続的な測定も、レジスタ書き込みまたはハードウェアピンによる 1 回のみの測定も可能です。本デバイスは、スレッシュホールド検出ロジックを備えており、センサが適切なウェイクアップ イベントが割り込みピン経由で報告されるのを待機している間、プロセッサはスリープできます。

このセンサは、I<sup>2</sup>C および SMBus 互換の 2 線式シリアル インターフェイス上の光レベルを表すデジタル出力を報告します。出力レジスタの内部先入れ先出し (FIFO) を使用すると、センサからの測定値を低速で読み出すと同時に、デバイスでキャプチャされたすべてのデータを保持できます。また、OPT4041 は I<sup>2</sup>C バースト モードもサポートしており、ホストは最小限の I<sup>2</sup>C オーバーヘッドで FIFO からデータを読み取ることができます。

OPT4041 は、低い消費電力と低い電源電圧で動作するので、バッテリー駆動システムのバッテリー動作時間を延長できます。

## Table of Contents

|   |    |  |    |
|---|----|--|----|
| <b>1 特長</b> .....                                       | 1  | 7.1 Register Descriptions .....                                  | 27 |
| <b>2 アプリケーション</b> .....                                 | 1  | <b>8 Application and Implementation</b> .....                    | 36 |
| <b>3 概要</b> .....                                       | 2  | 8.1 Application Information.....                                 | 36 |
| <b>4 Pin Configuration and Functions</b> .....          | 4  | 8.2 Typical Application.....                                     | 36 |
| <b>5 Specifications</b> .....                           | 5  | 8.3 Best Design Practices.....                                   | 38 |
| 5.1 Absolute Maximum Ratings.....                       | 5  | 8.4 Power Supply Recommendations.....                            | 38 |
| 5.2 ESD Ratings.....                                    | 5  | 8.5 Layout.....  | 38 |
| 5.3 Recommended Operating Conditions.....               | 5  | <b>9 Device and Documentation Support</b> .....                  | 41 |
| 5.4 Thermal Information.....                            | 5  | 9.1 Documentation Support.....                                   | 41 |
| 5.5 Electrical Characteristics.....                     | 6  | 9.2 ドキュメントの更新通知を受け取る方法.....                                      | 41 |
| 5.6 I <sup>2</sup> C Interface Timing Requirements..... | 8  | 9.3 サポート・リソース.....   | 41 |
| 5.7 I <sup>2</sup> C Timing Diagram.....                | 8  | 9.4 Trademarks.....  | 41 |
| 5.8 Typical Characteristics.....                        | 9  | 9.5 静電気放電に関する注意事項.....   | 41 |
| <b>6 Detailed Description</b> .....                     | 12 | 9.6 用語集.....   | 41 |
| 6.1 Overview.....                                       | 12 | <b>10 Revision History</b> .....                                 | 41 |
| 6.2 Functional Block Diagram.....                       | 12 | <b>11 Mechanical, Packaging, and Orderable Information</b> ..... | 41 |
| 6.3 Feature Description.....                            | 13 | 11.1 Mechanical Data.....  | 42 |
| 6.4 Device Functional Modes.....                        | 14 | 11.2 Package Option Addendum.....                                | 45 |
| 6.5 Programming.....                                    | 22 | 11.3 Tape and Reel Information.....                              | 46 |
| <b>7 Register Maps</b> .....                            | 26 |  |    |

## 4 Pin Configuration and Functions



図 4-1. DTS Package, 8-Pin SOT 5X3, Top View

表 4-1. Pin Functions

| PIN |      | TYPE          | DESCRIPTION   |
|-----|------|---------------|---|
| NO. | NAME |               |   |
| 1   | VDD  | Power         | Device power. Connect to a 1.6V to 3.6V supply.   |
| 2   | ADDR | Digital input | Address pin. This pin sets the LSBs of the I <sup>2</sup> C address.                      |
| 3   | NC   | No Connection | No Connection   |
| 4   | GND  | Power         | Ground  |
| 5   | SCL  | Digital input | I <sup>2</sup> C clock. Connect with a 10kΩ resistor to a 1.6V to 5.5V supply.            |
| 6   | NC   | No Connection | No Connection   |
| 7   | INT  | Digital I/O   | Interrupt input/output open-drain. Connect with a 10kΩ resistor to a 1.6V to 5.5V supply. |
| 8   | SDA  | Digital I/O   | I <sup>2</sup> C data. Connect with a 10kΩ resistor to a 1.6V to 5.5V supply.             |

## 5 Specifications

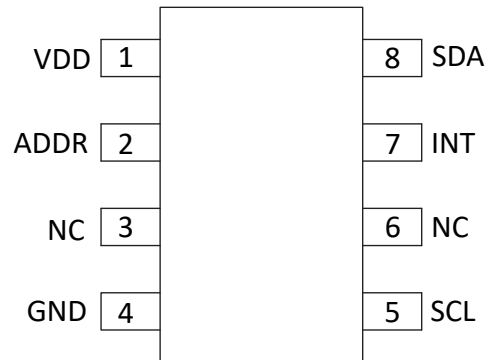
### 5.1 Absolute Maximum Ratings

over operating free-air temperature range (unless otherwise noted)<sup>(1)</sup>

|                       |                      | MIN  | MAX                | UNIT |
|-----------------------|----------------------|------|--------------------|------|
| Voltage               | VDD to GND           | −0.5 | 6                  | V    |
|                       | SDA and SCL to GND   | −0.5 | 6                  | V    |
| Current in to any pin |                      |      | 10                 | mA   |
| T <sub>J</sub>        | Junction temperature |      | 150                | °C   |
| T <sub>stg</sub>      | Storage temperature  | −65  | 150 <sup>(2)</sup> | °C   |

- (1) Operation outside the Absolute Maximum Ratings may cause permanent device damage. Absolute Maximum Ratings do not imply functional operation of the device at these or any other conditions beyond those listed under Recommended Operating Conditions. If used outside the Recommended Operating Conditions but within the Absolute Maximum Ratings, the device may not be fully functional, and this may affect device reliability, functionality, performance, and shorten the device lifetime.
- (2) Long exposure to temperatures higher than 105°C can cause package discoloration, spectral distortion, and measurement inaccuracy.

### 5.2 ESD Ratings

|                    |                         |  | VALUE | UNIT |
|--------------------|-------------------------|--|-------|------|
| V <sub>(ESD)</sub> | Electrostatic discharge | Human body model (HBM), per ANSI/ESDA/ JEDEC JS-001, all pins <sup>(1)</sup>     | ±2000 | V    |
|                    |                         | Charged device model (CDM), per ANSI/ESDA/ JEDEC JS-002, all pins <sup>(2)</sup> | ±500  |      |

- (1) JEDEC document JEP155 states that 500V HBM allows safe manufacturing with a standard ESD control process.
- (2) JEDEC document JEP157 states that 250V CDM allows safe manufacturing with a standard ESD control process.

### 5.3 Recommended Operating Conditions

over operating free-air temperature range (unless otherwise noted)

|                |                      | MIN | NOM | MAX | UNIT |
|----------------|----------------------|-----|-----|-----|------|
| VDD            | Supply voltage       | 1.6 |     | 3.6 | V    |
| T <sub>J</sub> | Junction temperature | −40 |     | 85  | °C   |

### 5.4 Thermal Information

| THERMAL METRIC <sup>(1)</sup> |  | OPT4041       | UNIT |
|-------------------------------|--|---------------|------|
|                               |  | SOT-5X3 (DTS) |      |
|                               |  | 8 Pins        |      |
| R <sub>θJA</sub>              | Junction-to-ambient thermal resistance       | 112.2         | °C/W |
| R <sub>θJC(top)</sub>         | Junction-to-case (top) thermal resistance    | 28.4          | °C/W |
| R <sub>θJB</sub>              | Junction-to-board thermal resistance         | 22.1          | °C/W |
| Ψ <sub>JT</sub>               | Junction-to-top characterization parameter   | 1.2           | °C/W |
| Ψ <sub>JB</sub>               | Junction-to-board characterization parameter | 22            | °C/W |

- (1) For more information about traditional and new thermal metrics, see the [Semiconductor and IC Package Thermal Metrics](#) application note.

## 5.5 Electrical Characteristics

All specifications at TA = 25°C, VDD = 3.3V, 800ms conversion-time (CONVERSION\_TIME=0xB), automatic full-scale range, white LED and normal-angle incidence of light, unless otherwise specified.

| PARAMETER               |   | TEST CONDITIONS   | MIN   | TYP    | MAX  | UNIT                         |
|-------------------------|---|---|-------|--------|------|------------------------------|
| <b>OPTICAL</b>          |   |   |       |        |      |                              |
|                         | Number of channels  |   |       | 2      |      |                              |
|                         | Peak irradiance spectral responsivity   | CH0 (ALS)   |       | 561    |      | nm                           |
|                         |   | CH1 (WB)  |       | 518    |      | nm                           |
|                         | ADC resolution  |   | 9     |        | 20   | bits                         |
|                         | Range determination   | CH0 (ALS)   |       | 4      |      | bits                         |
|                         |   | CH1 (WB)  |       | 3      |      | bits                         |
| Tconv                   | Light Conversion-time per channel <sup>(4)</sup>                                | Conversion-time CT = 0x6  |       | 25     |      | ms                           |
|                         |   | Conversion-time CT = 0xB  |       | 800    |      | ms                           |
| E <sub>vLSB</sub>       | Equivalent resolution CH0 (ALS)   | Lowest auto gain range, 800ms conversion-time per channel                 |       | 585    |      | μlux                         |
|                         |   | Lowest auto gain range, 100ms conversion-time per channel                 |       | 4.68   |      | mlux                         |
|                         | Equivalent resolution CH1 (IR)  | Lowest auto gain range, 800ms conversion-time per channel, 520nm stimulus |       | 0.1923 |      | nW/cm <sup>2</sup>           |
|                         |   | Lowest auto gain range, 100ms conversion-time per channel, 520nm stimulus |       | 1.538  |      | nW/cm <sup>2</sup>           |
| Peak responsivity       | CH0 (ALS) Lowest auto gain range, 800ms conversion per channel                  |   | 11400 |        |      | codes per μW/cm <sup>2</sup> |
|                         | CH1 (WB) Lowest auto gain range, 800ms conversion per channel                   |   | 5200  |        |      | codes per μW/cm <sup>2</sup> |
| E <sub>vFS</sub>        | Full-scale Illuminance  | CH0 (ALS)   |       | 157035 |      | lux                          |
|                         |   | CH1 (WB)  |       | 12.91  |      | mW/cm <sup>2</sup>           |
| E <sub>v</sub>          | Measurement output result for ALS Channel (CH0)                                 | 2000 lux input <sup>(1)</sup>   | 1800  | 2000   | 2200 | lux                          |
|                         | Relative accuracy between gain ranges <sup>(2)</sup>                            | All channels  |       | 0.6    |      | %                            |
| E <sub>vIR</sub>        | Infrared response   | 850-nm near infrared, CH0 (ALS) response                                  |       | 0.2    |      | %                            |
|                         | Light source variation for lux measurement (incandescent, halogen, fluorescent) | Bare device, no cover glass   |       | 4      |      | %                            |
| Linearity               |   | EXPONENT_CHx > 0, 100ms conversion-time CT=8, all channels                |       | 2      |      | %                            |
|                         |   | EXPONENT_CHx = 0, 100ms conversion-time CT=8, all channels                |       | 5      |      | %                            |
|                         | Drift across temperature  | All channels  |       | 0.01   |      | %/°C                         |
|                         | Dark Measurement  | All channels  |       | 0      | 10   | codes                        |
| Angular response (FWHM) |   | CH0 (ALS)   |       | 121    |      | °                            |
|                         |   | CH1 (WB)  |       | 128    |      | °                            |
| PSRR                    | Power-supply rejection ratio <sup>(3)</sup>                                     | VDD at 3.6V and 1.6V, all channels  |       | 0.1    |      | %/V                          |
| <b>POWER SUPPLY</b>     |   |   |       |        |      |                              |
| V <sub>DD</sub>         | Power supply  |   | 1.6   |        | 3.6  | V                            |
| V <sub>I2C</sub>        | Power supply for I <sup>2</sup> C pull up resistor                              | I <sup>2</sup> C pullup resistor, V <sub>DD</sub> ≤ V <sub>I2C</sub>      | 1.6   |        | 5.5  | V                            |

All specifications at TA = 25°C, VDD = 3.3V, 800ms conversion-time (CONVERSION\_TIME=0xB), automatic full-scale range, white LED and normal-angle incidence of light, unless otherwise specified.

| PARAMETER            |  | TEST CONDITIONS                      | MIN                   | TYP  | MAX                   | UNIT |
|----------------------|--|--------------------------------------|-----------------------|------|-----------------------|------|
| I <sub>QACTIVE</sub> | Active Current                                       | Dark                                 |                       | 24   |                       | μA   |
|                      |  | Full-scale lux                       |                       | 29   |                       | μA   |
| I <sub>Q</sub>       | Quiescent current                                    | Dark                                 |                       | 2    |                       | μA   |
|                      |  | Full-scale lux                       |                       | 2.6  |                       | μA   |
| POR                  | Power-on-reset threshold                             |                                      |                       | 0.8  |                       | V    |
| <b>DIGITAL</b>       |  |                                      |                       |      |                       |      |
| C <sub>IO</sub>      | I/O Pin Capacitance                                  |                                      |                       | 3    |                       | pF   |
| T <sub>ss</sub>      | Trigger to Sample Start                              | Low-power shutdown mode              |                       | 0.5  |                       | ms   |
| V <sub>IL</sub>      | Low-level input voltage (SDA, SCL, and ADDR)         |                                      | 0                     |      | 0.3 X V <sub>DD</sub> | V    |
| V <sub>IH</sub>      | High-level input voltage (SDA, SCL, and ADDR)        |                                      | 0.7 X V <sub>DD</sub> |      | 5.5                   | V    |
| I <sub>IL</sub>      | Low-level input current (SDA, SCL, and ADDR)         |                                      |                       | 0.01 | 0.25 <sup>(5)</sup>   | μA   |
| V <sub>OL</sub>      | Low-level output voltage (SDA and INT)               | I <sub>OL</sub> =3mA                 |                       |      | 0.32                  | V    |
| I <sub>ZH</sub>      | Output logic high, high-Z leakage current (SDA, INT) | Measured with V <sub>DD</sub> at pin |                       | 0.01 | 0.25 <sup>(5)</sup>   | μA   |
| <b>TEMPERATURE</b>   |  |                                      |                       |      |                       |      |
|                      | Specified temperature range                          |                                      | -40                   |      | 85                    | °C   |

- (1) Tested with the white LED calibrated to 2000lux
- (2) Characterized by measuring fixed near-full-scale light levels on the higher adjacent full-scale range setting.
- (3) PSRR is the percent change of the measured lux output from its current value, divided by the change in power supply voltage, as characterized by results from 3.6V and 1.6V power supplies
- (4) The conversion-time, from start of conversion until the data are ready to be read, is the integration-time plus analog-to-digital conversion-time.
- (5) The specified leakage current is dominated by the production test equipment limitations. Typical values are much smaller

## 5.6 I<sup>2</sup>C Interface Timing Requirements

All timing parameters are referenced to low and high voltage thresholds of 30% and 70%, respectively, of the final settled value.

|                                       |  | MIN  | TYP | MAX | UNIT |
|---------------------------------------|--|------|-----|-----|------|
| <b>I<sup>2</sup>C FAST MODE</b>       |  |      |     |     |      |
| f <sub>SCL</sub>                      | Clock operating frequency  | 0.01 |     | 0.4 | MHz  |
| t <sub>BUF</sub>                      | Bus free time between stop and start   | 1300 |     |     | ns   |
| t <sub>HDSTA</sub>                    | Hold time after repeated start   | 600  |     |     | ns   |
| t <sub>SUSTA</sub>                    | Setup time for repeated start  | 600  |     |     | ns   |
| t <sub>SUSTO</sub>                    | Setup time for stop  | 600  |     |     | ns   |
| t <sub>HDDAT</sub>                    | Data hold time   | 20   |     | 900 | ns   |
| t <sub>SUDAT</sub>                    | Data setup time  | 100  |     |     | ns   |
| t <sub>LOW</sub>                      | Clock low period   | 1300 |     |     | ns   |
| t <sub>HIGH</sub>                     | Clock high period  | 600  |     |     | ns   |
| t <sub>RC</sub> and t <sub>FC</sub>   | Clock rise and fall time   |      |     | 300 | ns   |
| t <sub>RD</sub> and t <sub>FD</sub>   | Data rise and fall time  |      |     | 300 | ns   |
| t <sub>TIMEO</sub>                    | Bus timeout period. If the clock line is held low for this duration of time, the bus state machine is reset. |      | 28  |     | ms   |
| <b>I<sup>2</sup>C HIGH-SPEED MODE</b> |  |      |     |     |      |
| f <sub>SCL</sub>                      | Clock operating frequency  | 0.01 |     | 2.6 | MHz  |
| t <sub>BUF</sub>                      | Bus free time between stop and start   | 160  |     |     | ns   |
| t <sub>HDSTA</sub>                    | Hold time after repeated start   | 160  |     |     | ns   |
| t <sub>SUSTA</sub>                    | Setup time for repeated start  | 160  |     |     | ns   |
| t <sub>SUSTO</sub>                    | Setup time for stop  | 160  |     |     | ns   |
| t <sub>HDDAT</sub>                    | Data hold time   | 20   |     | 140 | ns   |
| t <sub>SUDAT</sub>                    | Data setup time  | 20   |     |     | ns   |
| t <sub>LOW</sub>                      | Clock low period   | 240  |     |     | ns   |
| t <sub>HIGH</sub>                     | Clock high period  | 60   |     |     | ns   |
| t <sub>RC</sub> and t <sub>FC</sub>   | Clock rise and fall time   |      |     | 40  | ns   |
| t <sub>RD</sub> and t <sub>FD</sub>   | Data rise and fall time  |      |     | 80  | ns   |
| t <sub>TIMEO</sub>                    | Bus timeout period. If the clock line is held low for this duration of time, the bus state machine is reset. |      | 28  |     | ms   |

## 5.7 I<sup>2</sup>C Timing Diagram

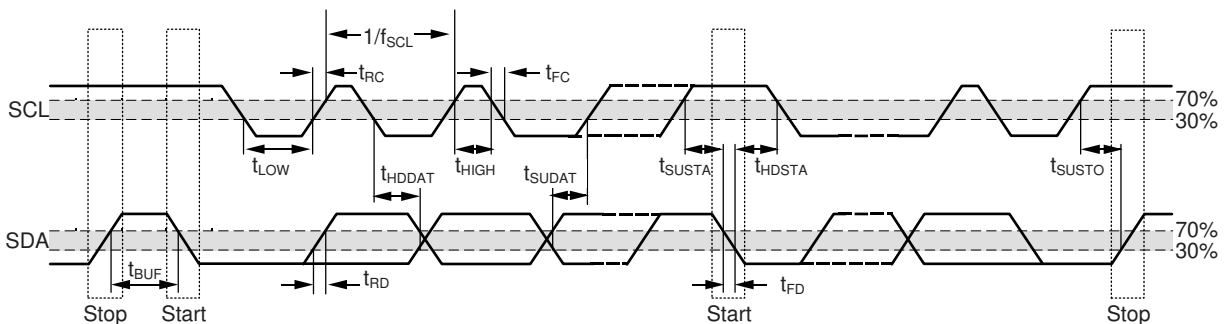

5-1. I<sup>2</sup>C Detailed Timing Diagram

### 5.8 Typical Characteristics

At  $T_A = 25^\circ\text{C}$ ,  $V_{DD} = 3.3\text{V}$ , 800ms conversion time (CONVERSION\_TIME = 0xB), automatic full-scale range (RANGE = 0xC), white LED, and normal-angle incidence of light, unless otherwise specified.

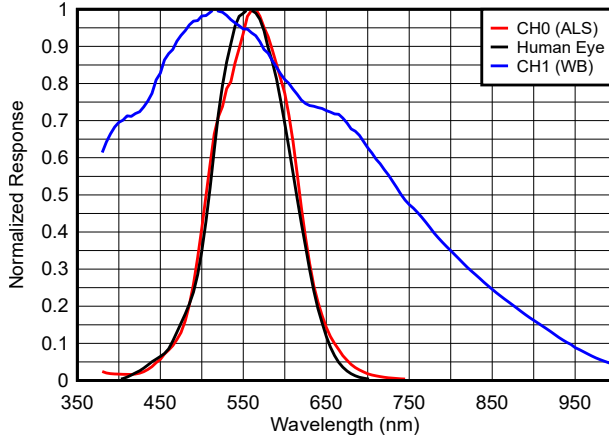

Figure 5-2. Spectral Response vs Wavelength

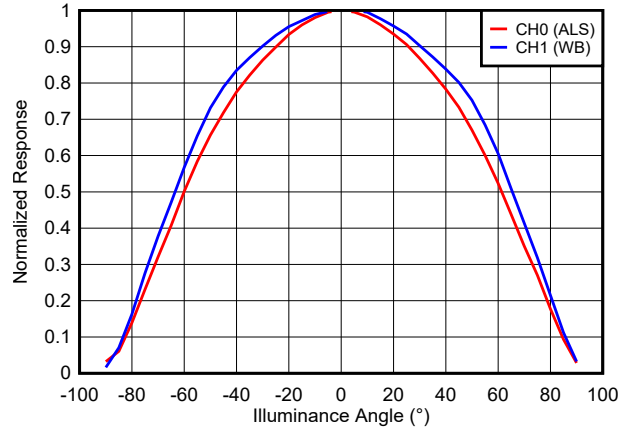
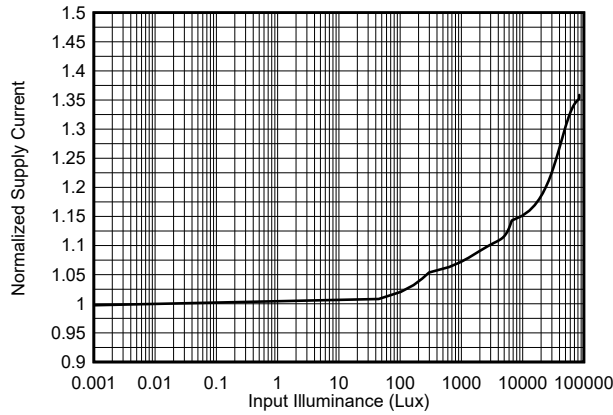
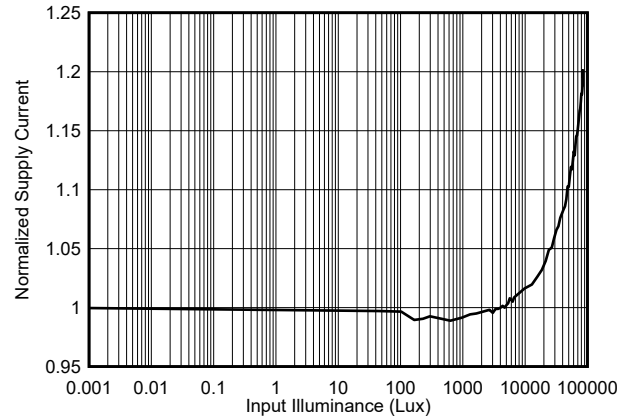

Figure 5-3. Device Response vs Illuminance Angle



Normalized to dark condition

Figure 5-4. Active Current vs Input Light Level



Normalized to dark condition

Figure 5-5. Standby Current vs Input Light Level

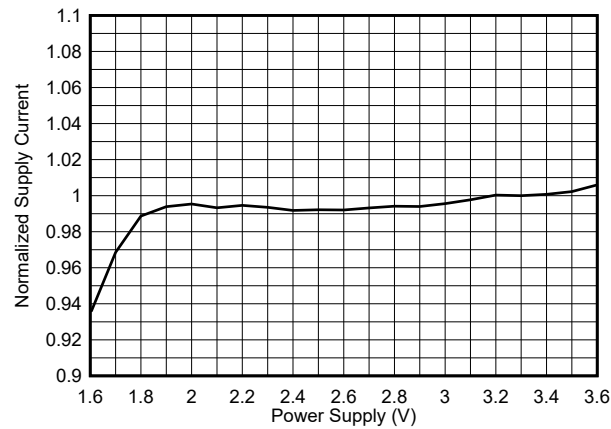

Normalized to 3.3V

Figure 5-6. Active Current vs Power Supply

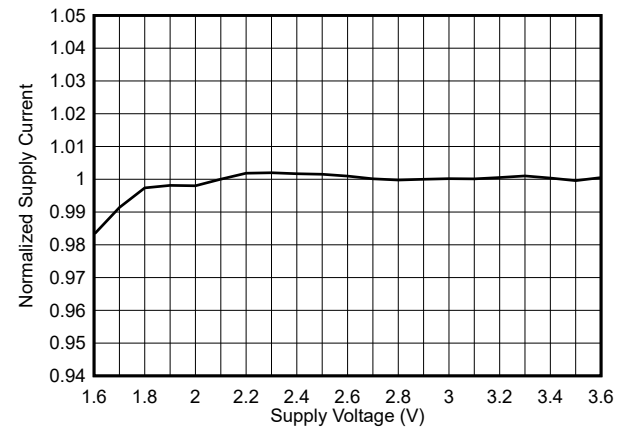

Normalized to 3.3 V

Figure 5-7. Standby Current vs Power Supply

### 5.8 Typical Characteristics (continued)

At  $T_A = 25^\circ\text{C}$ ,  $V_{DD} = 3.3\text{V}$ , 800ms conversion time (CONVERSION\_TIME = 0xB), automatic full-scale range (RANGE = 0xC), white LED, and normal-angle incidence of light, unless otherwise specified.

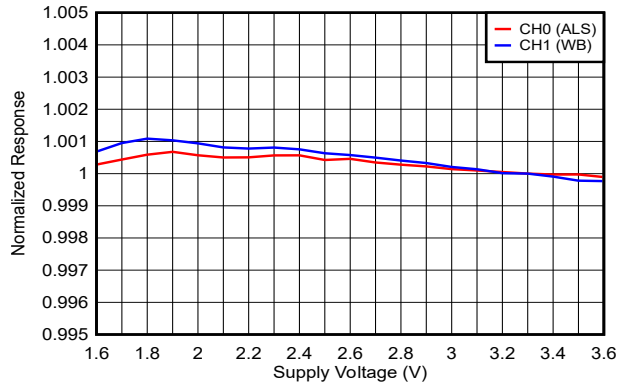

Normalized to 3.3 V

图 5-8. Device Response vs Power Supply

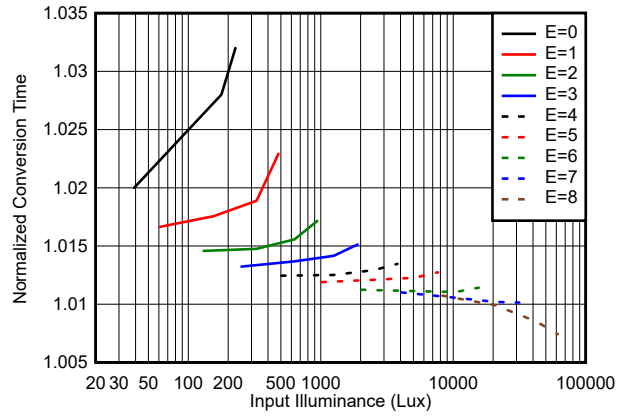

Register E (exponent) denotes the full-scale range  
Normalized to 25 ms

图 5-9. Conversion Time at 25 ms vs Input Light Level

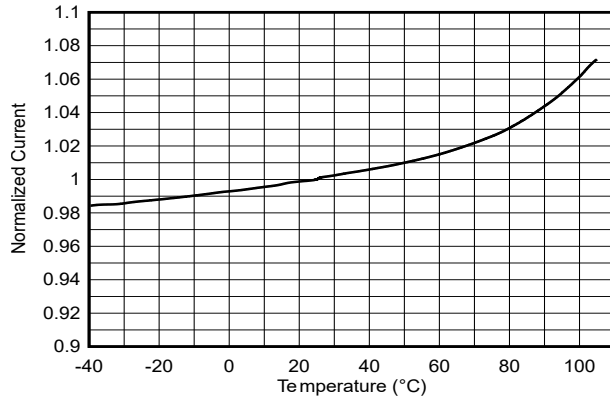

Normalized to 25°C

图 5-10. Active Current vs Temperature

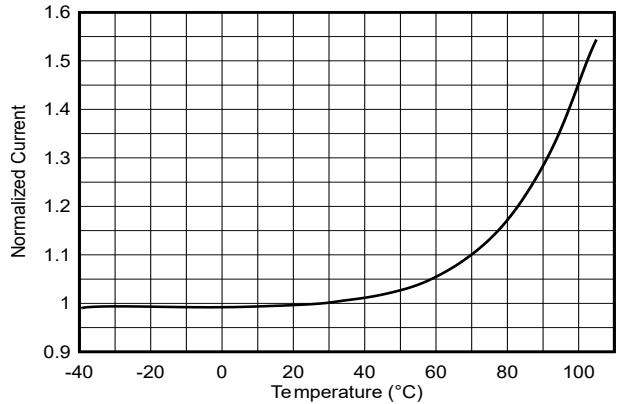

Normalized to 25°C

图 5-11. Standby Current vs Temperature

### 5.8 Typical Characteristics (continued)

At  $T_A = 25^\circ\text{C}$ ,  $V_{DD} = 3.3\text{V}$ , 800ms conversion time (CONVERSION\_TIME = 0xB), automatic full-scale range (RANGE = 0xC), white LED, and normal-angle incidence of light, unless otherwise specified.

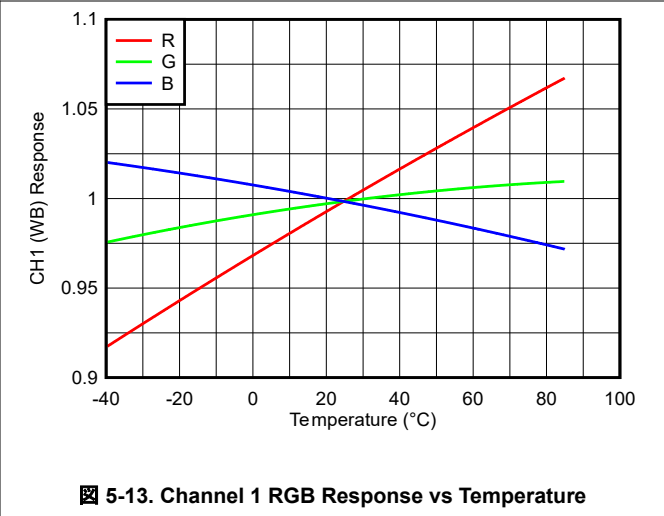
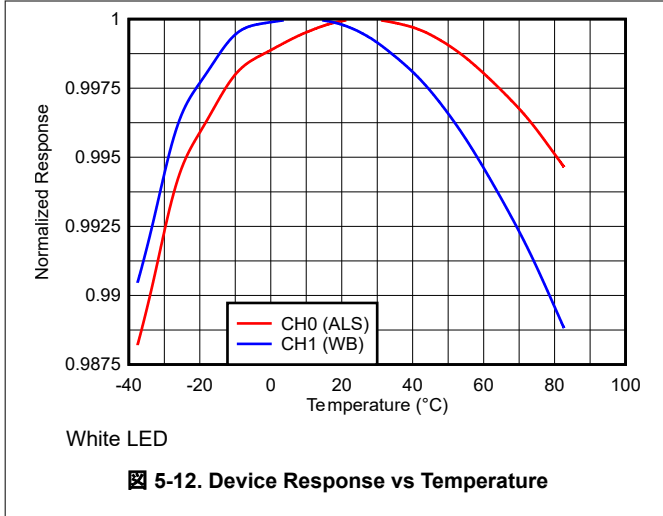

## 6 Detailed Description

### 6.1 Overview

OPT4041 measures the ambient light that illuminates the device. This device measures light with a spectral response very closely matched to the human eye, and with excellent infrared rejection.

Matching the sensor spectral response to that of the human eye response is vital because ambient light sensors are used to measure and help create ideal human lighting experiences. Strong rejection of infrared light, which a human does not see, is a crucial component of this matching. This matching makes the OPT4041 especially good for operation underneath windows that are visibly dark, but infrared transmissive.

The wide band channel is sensitive to a broad range of wavelengths, including 850nm and 940nm NIR wavelengths. This enables accurate measurement of a wide range of sources.

OPT4041 is fully self-contained to measure the ambient light and report the result in ADC codes directly proportional to lux digitally over the I<sup>2</sup>C bus. The result can also be used to alert a system and interrupt a processor with the INT pin. The result can also be summarized with a programmable threshold comparison and communicated with the INT pin.

OPT4041 is by default configured to operate in automatic full-scale range detection mode that always selects the optimal full-scale range setting for the given lighting conditions. There are 9 full-scale range settings one of which can be selected manually as well. Setting the device to operate in automatic full-scale range detection mode frees the user from having to program the software for potential iterative cycles of measurement and readjustment of the full-scale range until optimal for any given measurement. With device exhibiting excellent linearity over the entire 28 bit dynamic range of measurement no additional linearity calibration is required at system level.

OPT4041 can be configured to operate in continuous or one-shot measurement modes. The device offers 12 conversion times ranging from 600µs to 800ms. The device starts up in a low-power shutdown state, such that the OPT4041 only consumes active-operation power after being programmed into an active state.

OPT4041 optical filtering system is not excessively sensitive to non-ideal particles and micro-shadows on the optical surface. This reduced sensitivity is a result of the relatively minor device dependency on uniform density optical illumination of the sensor area for infrared rejection. Proper optical surface cleanliness is always recommended for best results on all optical devices.

### 6.2 Functional Block Diagram



図 6-1. Functional Block Diagram of OPT4041

## 6.3 Feature Description

### 6.3.1 Spectral Response

#### 6.3.1.1 Channel 0: Human Eye Matching

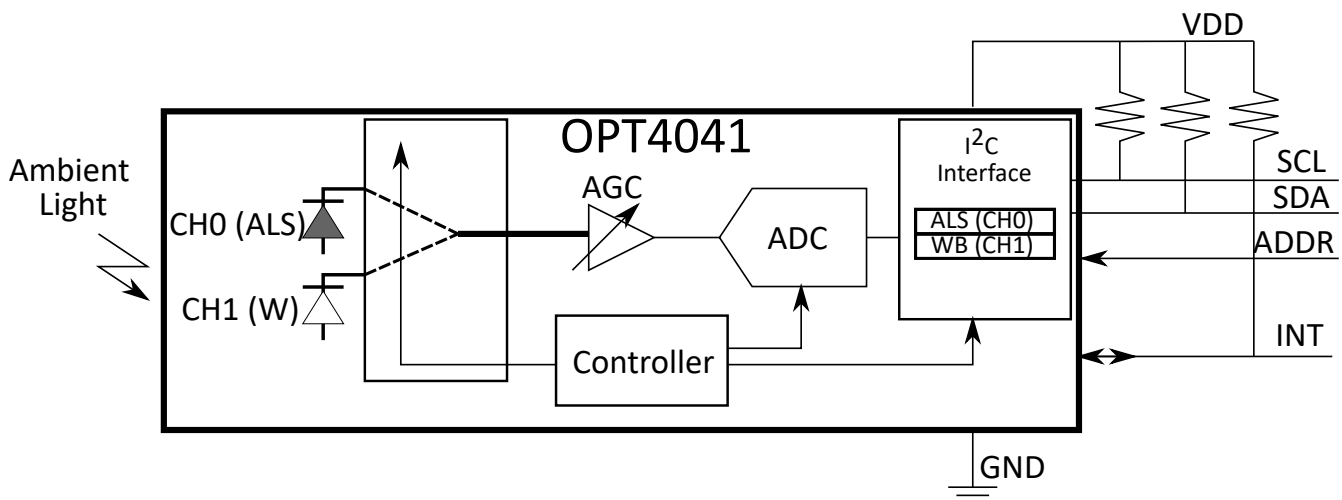
The OPT4041 spectral response closely matches that of the human eye. If the ambient light sensor measurement is used to help create a good human experience, or create optical conditions that are optimal for a human, the sensor must measure the same spectrum of light that a human sees.

The OPT4041 also has excellent infrared light (IR) rejection. This IR rejection is especially important because many real-world lighting sources have significant infrared content that humans do not see. If the sensor measures infrared light that the human eye does not see, then a true human experience is not accurately represented.

If the application demands hiding the OPT4041 underneath a dark window (such that the end-product user cannot see the sensor) the infrared rejection of the OPT4041 becomes significantly more important because many dark windows attenuate visible light but transmit infrared light. This attenuation of visible light and lack of attenuation of IR light amplifies the ratio of the infrared light to visible light that illuminates the sensor. Results can still be well matched to the human eye under this condition because of the high infrared rejection of the OPT4041.

#### 6.3.1.2 Channel 1: Wide Band

Channel 1 of the OPT4041 has a wide spectral bandwidth, ranging from 380nm to 1000nm. The wide band channel enables the OPT4041 to perform measurements in applications with a variety of wavelengths, and the NIR response can be useful for monitoring IR LEDs or performing overall system calibrations. For example, the channel 1 NIR measurements can be used in systems where fast calibration of camera exposure settings is required.

### 6.3.2 Automatic Full-Scale Range Setting

The OPT4041 has an automatic full-scale range setting feature that eliminates the need to predict and set the optimal range for the device. In this mode, the device automatically selects the optimal full-scale range for varying lighting condition each measurement. The device has a high degree of result matching between the full-scale range settings. This matching eliminates the problem of varying results or the need for range-specific, user-calibrated gain factors when different full-scale ranges are chosen.

### 6.3.3 Output Register CRC and Counter

The OPT4041 device features additional bits as part of the output register which helps in improving the reliability of light measurements for the application.

#### 6.3.3.1 Output Sample Counter

The OPT4041 device features **COUNTER** registers as part of the output registers for both channels which increment for every successful measurement. These registers can be read as part of the output registers which helps the application to keep track of measurements. The 4 bit counter starts at 0 on power-up and counts up to 15 after which the counter resets back to 0 and continues to count up. This is particularly helpful in situations such as the following:

- Host or Controller needs consecutive measurements. Utilizing the **COUNTER** registers, the controller can compare samples and verifies that the samples are in expected order without missing intermediate counter values.
- As a safety feature when the light level is not changing, the controller can verify that the measurements from OPT4041 are not stuck by comparing values of the **COUNTER** registers between measurements. If the **COUNTER** values continue to change over samples, the device updates the output register with the most recent measurement of light levels.

### 6.3.3.2 Output CRC

The CRC register consists of Cyclic Redundancy Checker bits as part of the output registers calculated within the OPT4041 device and is updated on every measurement. This feature helps in detecting communication related bit errors during the output readout from the device. [Register 1h](#) lists the calculation method for the CRC bits, which can be independently verified in the controller or host firmware and software to validate if communication between the controller and the device is successful without bit errors during transmission.

### 6.3.4 Threshold Detection

OPT4041 features a threshold detection logic which can be programmed to indicate and update register flags if measured light levels cross thresholds set by the user. The threshold condition can be programmed to use one of the two channels as a trigger, as determined by the [THRESHOLD\\_CH\\_SEL](#) register. There are independent low and high threshold target registers with independent flag registers to indicate the status of measured light level. Measured light levels reaching below the low threshold and above the high threshold are called faults. Users can program a fault count register, which counts consecutive number of faults before the flag registers are set. This is particularly useful in cases where the controller can read the flag register alone to get an indication of the measured light level without needing to perform lux calculations. Calculations for setting up the threshold are available in the [セクション 6.4.6](#) section.

## 6.4 Device Functional Modes

### 6.4.1 Modes of Operation

The OPT4041 has the following modes of operation:

- **Power-down mode:** This mode is a power-down or standby mode where the device enters a low-power state. There is no active light sensing or conversion in this mode. The device still responds to I<sup>2</sup>C transactions that can be used to bring the device out of this mode. The OPERATING\_MODE register is set to 0.
- **Continuous mode:** In this mode, the OPT4041 measures and updates the output registers continuously as determined by the conversion time and generates a hardware interrupt on the INT pin for every successful conversion. Configure the INT pin in output mode using the INT\_DIR register. The device active circuits are continuously kept active to minimize the interval between measurements. The OPERATING\_MODE register is set to 3.
- **One-shot mode:** There are two ways in which the OPT4041 can be used in one-shot mode of operation with one common theme where the OPT4041 stays in standby mode and a conversion is triggered either by a register write to the configuration register or by a hardware interrupt on the INT pin.

There are two types of one-shot modes.

- **Force auto-range one-shot mode:** Every one-shot trigger forces a full reset on the auto-ranging control logic and a fresh auto-range detection is initiated, ignoring the previous measurements. This mode is particularly useful in situations where lighting conditions are expected to change frequently and the conditions for the one-shot trigger frequency are not expected to change very often. There is a small penalty on conversion time resulting from the auto-ranging logic recovering from a reset state. The full reset cycle on the auto-ranging control logic takes approximately 500µs, which must be accounted for between measurements when this mode is used. The OPERATING\_MODE register is set to 1.
- **Regular auto-range one-shot mode:** Auto-range selection logic uses the information from the previous measurements to determine the range for the current trigger. Only use this mode when the device needs time-synchronized measurements with frequent triggers from the controller. In other words, this mode can be used as an alternative to continuous mode. The key difference between these modes is that the interval between measurements is determined by the one-shot triggers. The OPERATING\_MODE register is set to 2.

One-shot mode can be triggered by the following:

- **Hardware trigger:** The INT pin can be configured as an input to trigger a measurement, setting the INT\_DIR register to 0. When the INT pin is used as input, there is no hardware interrupt to indicate

completion of measurement. The controller must keep time from the trigger mechanism and read out output registers.

- **Register trigger:** An I<sup>2</sup>C write to the OPERATING\_MODE register triggers a measurement (value of 1 or 2). The register value is reset after the next successful measurement. The INT pin can be configured to indicate measurement completion to read out the output registers by setting the INT\_DIR register to 1.

The interval between subsequent triggers must be set to account for all aspects involved in the trigger mechanism, such as the I<sup>2</sup>C transaction time, device wake-up time, auto-range time (if used), and device conversion time. If a conversion trigger is received before the completion of the current measurement, the device simply ignores the new request until the previous conversion is completed.

The device enters standby after each one-shot trigger; therefore, the measurement interval in the one-shot trigger mechanism must account for additional time ( $t_{ss}$  time, as specified in *Specifications* for the circuits to recover from standby state. However, setting the quick wake-up register QWAKE eliminates the need for this additional  $t_{ss}$  at the cost of not powering down the active circuit with the device not entering standby mode between triggers.

☒ 6-2 illustrates a timing diagram of the various operating modes.



図 6-2. Timing Diagrams for Different Operating Modes

### 6.4.2 Interrupt Modes of Operation

The device has an interrupt reporting system that allows the processor connected to the I<sup>2</sup>C bus to go to sleep, or otherwise ignore the device results, until a user-defined event occurs that requires possible action. Alternatively, this same mechanism can also be used with any system that can take advantage of a single digital signal that indicates whether the light is above or below levels of interest.

The INT pin has an open-drain output, which requires the use of a pullup resistor. This open-drain output allows multiple devices with open-drain INT pins to be connected to the same line, thus creating a logical *NOR* or *AND* function between the devices. The polarity of the INT pin can be controlled by the `INT_POL` register.

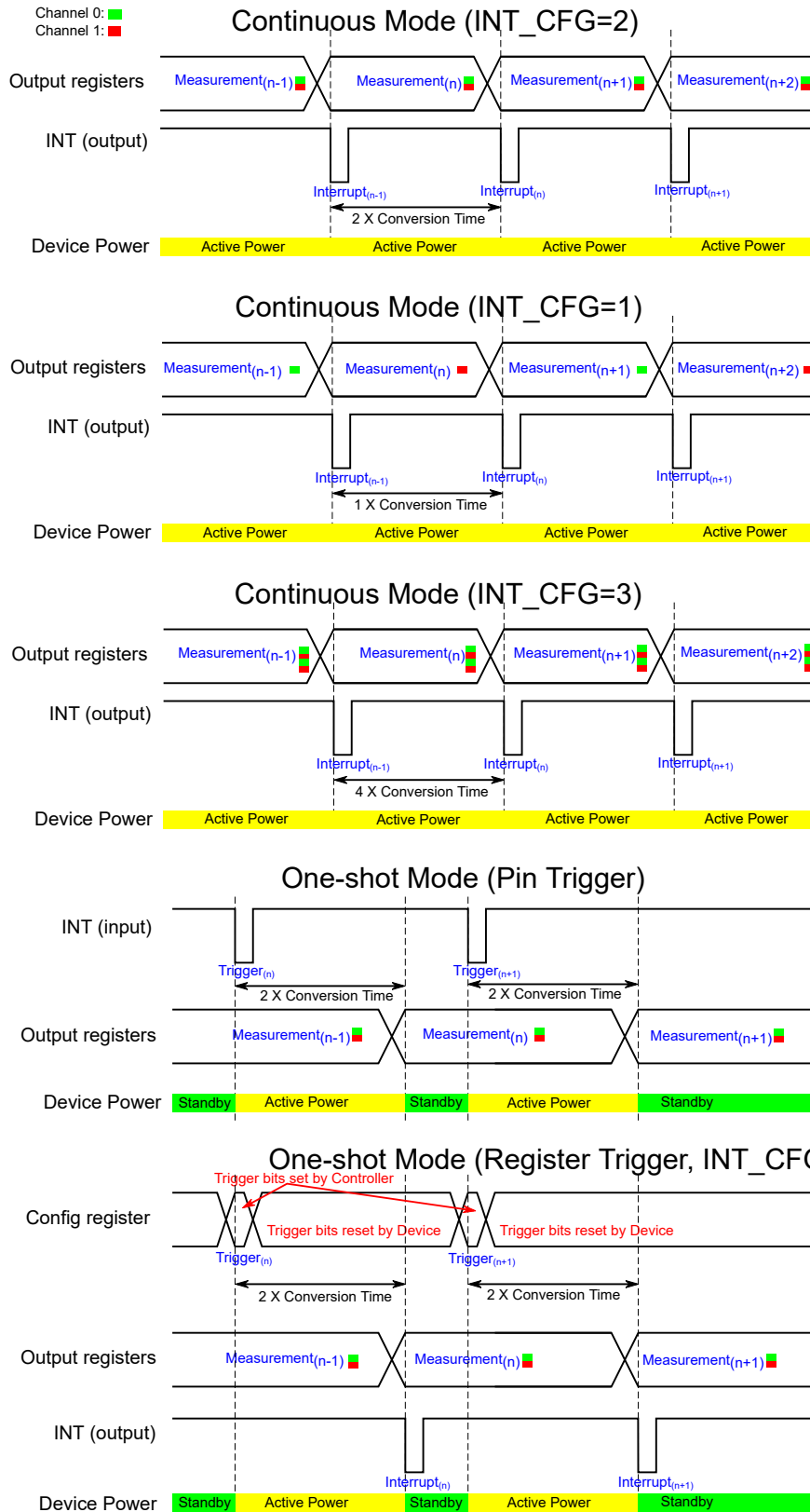
There are two major types of interrupt reporting mechanism modes: latched window comparison mode and transparent hysteresis comparison mode. The `LATCH` configuration register controls which of these two modes is used. 図 6-3 and 表 6-1 summarize the function of these two modes. Additionally, the INT pin can either be used to indicate a fault in one of these modes (`INT_CFG = 0`) or to indicate a conversion completion (`INT_CFG > 0`). 表 6-2 details this functionality.



図 6-3. Interrupt Pin Status (`INT_CFG = 0` Setting) and Register Flag Behavior

表 6-1. Interrupt Pin Status (INT\_CFG = 0 Setting) and Register Flag Behavior

| LATCH SETTING                  | INT PIN STATE (WHEN INT_CFG=0)  | FLAG_H VALUE  | FLAG_L VALUE  | LATCHING BEHAVIOR   |
|--------------------------------|---|---|---|---|
| 0: Transparent hysteresis mode | The INT pin indicates if measurement is above (INT active) or below (INT inactive) the threshold. If measurement is between the high and low threshold values, then the previous INT value is maintained. This mode prevents the INT pin from repeated toggling when the measurement values are close to the threshold. | 0: If measurement is below the low limit<br>1: If measurement is above the high limit<br>If measurement is between the high and low limits, the previous value is maintained. | 0: If measurement is above the high limit<br>1: If measurement is below the low limit<br>If measurement is between the high and low limits, the previous value is maintained. | Not latching: Values are updated after each conversion  |
| 1: Latched window mode         | The INT pin becomes active if the measurement is outside the window (above the high threshold or below the low threshold). The INT pin does not reset and returns to the inactive state until the 0xC is register read.   | 1: If measurement is above the high limit   | 1: If measurement is below the low limit  | Latching: The INT pin, FLAG_H, and FLAG_L values do not reset until the 0xC register is read. |

The THRESHOLD\_H, THRESHOLD\_L, LATCH, and FAULT\_COUNT registers control the interrupt behavior. As shown in 表 6-1, the LATCH field setting provides a choice between the latched window mode and transparent hysteresis mode. Interrupt reporting can be observed on the INT pin, the FLAG\_H, and the FLAG\_L registers.

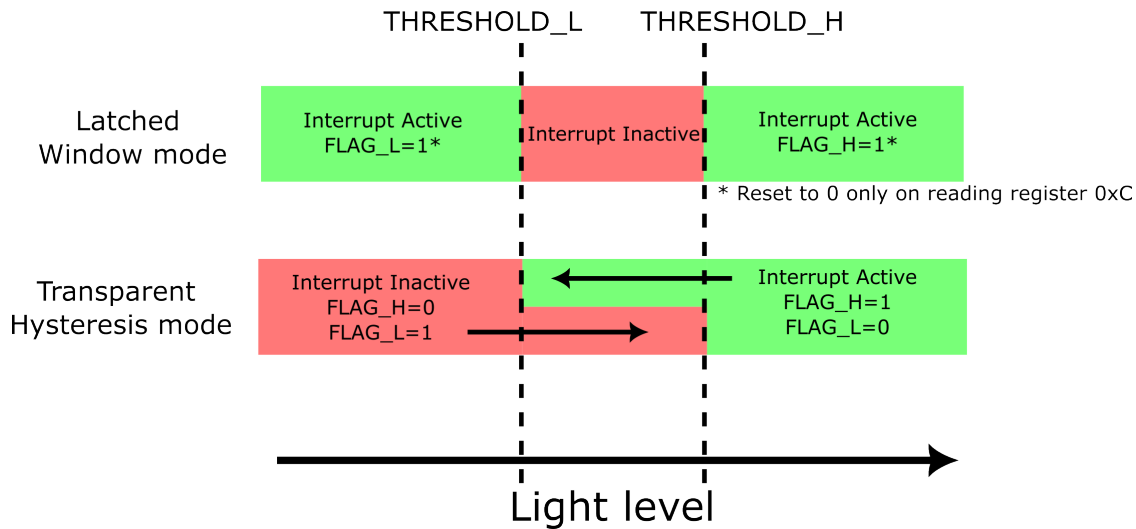
Results from comparing the current sensor measurements with the THRESHOLD\_H and THRESHOLD\_L registers are referred to as *fault events*. See the [セクション 6.4.6](#) section for the calculations to set these registers. The FAULT\_COUNT register dictates the number of continuous *fault events* required to trigger an interrupt event and subsequently change the state of the interrupt reporting mechanisms. For example, with a FAULT\_COUNT value of 2 corresponding to four fault counts, the INT pin, FLAG\_H, and FLAG\_L states shown in [図 6-3](#) are not realized unless four consecutive measurements are taken that satisfy the fault condition.

The INT pin function listed in [図 6-3](#) is valid only when INT\_CFG = 0. As described in 表 6-2, the INT pin function can be changed to indicate an end of conversion or FIFO full state. The FLAG\_H and FLAG\_L registers continue to behave as listed in [図 6-3](#), even while INT\_CFG > 0. The polarity of the INT pin is controlled by the INT\_POL register.

表 6-2. INT\_CFG Setting and Resulting INT Pin Behavior

| INT_CFG SETTING | INT PIN FUNCTION  |
|-----------------|---|
| 0               | As per <a href="#">図 6-3</a>  |
| 1               | INT pin asserted with a 1μs pulse duration after every conversion   |
| 2               | INT pin asserted with a 1μs pulse duration every two conversions to indicate both channel measurements are complete |
| 3               | INT pin asserted with a 1μs pulse duration every four conversions to indicate the FIFO is full                      |

### 6.4.3 Light Range Selection

The OPT4041 has an automatic full-scale-range setting mode that eliminates the need for a user to predict and set the optimal range for the device. Set the RANGE register to 0xC to enter this mode. The device determines the appropriate full-scale range to take the measurement based on a combination of current lighting conditions and the previous measurement.

If a measurement is towards the low side of full-scale, then the full-scale range is decreased by one or two settings for the next measurement. If a measurement is towards the upper side of full-scale, the full-scale range is increased by one setting for the next measurement.

If the measurement exceeds the full-scale range, resulting from a fast increasing optical transient event, the current measurement is aborted. This invalid measurement is not reported. If the scale is not at the maximum, the device increases the scale by one step and a new measurement is retaken with that scale. Therefore, during a fast increasing optical transient in this mode, a measurement can possibly take longer to complete and report than indicated by the [CONVERSION\\_TIME](#) configuration register.

Using this feature is highly recommended because the device selects the best range setting based on lighting conditions. However, there is an option to manually set the range. Setting the range manually turns off the automatic full-scale selection logic and the device operates for a particular range setting. [表 6-3](#) lists the range selection settings.

**表 6-3. Range Selection Table**

| RANGE register setting | CH0 Typical Full-Scale Light Level   | CH0 Exponent | CH1 Typical Full-Scale Light Level | CH1 Exponent |
|------------------------|--|--------------|------------------------------------|--------------|
| 0                      | 613lux   | 0            | 0.202mW/cm <sup>2</sup>            | 0            |
| 1                      | 1227lux  | 1            | 0.403mW/cm <sup>2</sup>            | 1            |
| 2                      | 2454lux  | 2            | 0.807mW/cm <sup>2</sup>            | 2            |
| 3                      | 4907lux  | 3            | 1.61mW/cm <sup>2</sup>             | 3            |
| 4                      | 9815lux  | 4            | 3.23mW/cm <sup>2</sup>             | 4            |
| 5                      | 19629lux   | 5            | 6.45mW/cm <sup>2</sup>             | 5            |
| 6                      | 39259lux   | 6            | 12.91mW/cm <sup>2</sup>            | 6            |
| 7                      | 78517lux   | 7            | 12.91mW/cm <sup>2</sup>            | 6            |
| 8                      | 157035lux  | 8            | 12.91mW/cm <sup>2</sup>            | 6            |
| 12                     | Determined by automatic full-scale range logic; sets channel 0 and channel 1 independently |              |                                    |              |

#### 6.4.4 Selecting Conversion Time

As listed in [表 6-4](#), the OPT4041 offers several conversion times that can be selected. Conversion time is defined as the time taken from initiation to completion of one measurement, including the time taken to update the results in the output register. Measurement initiation is determined by the mode of operation, as specified in [セクション 6.4.1](#).

**表 6-4. Conversion Time Selection**

| CONVERSION_TIME register | Typical Conversion time |
|--------------------------|-------------------------|
| 0                        | 0.6ms                   |
| 1                        | 1ms                     |
| 2                        | 1.8ms                   |
| 3                        | 3.4ms                   |
| 4                        | 6.5ms                   |
| 5                        | 12.7ms                  |
| 6                        | 25ms                    |
| 7                        | 50ms                    |
| 8                        | 100ms                   |
| 9                        | 200ms                   |
| 10                       | 400ms                   |
| 11                       | 800ms                   |

### 6.4.5 Light Measurement in Lux

The OPT4041 measures light and updates output registers with proportional ADC codes. The output of the device is represented by two parts: by four EXPONENT register bits and by 20 MANTISSA bits. This arrangement of binary logarithmic full-scale ranges with linear representation in a range helps cover a large dynamic range of measurements. MANTISSA represents the linear ADC codes proportional to the measured light within a given full-scale range and the EXPONENT bits represent the current full-scale range selected. The selected range can either be automatically determined by the auto-range selection logic or manually selected as per [表 6-3](#)

The lux level can be determined using the following equations. First, use [Equation 1](#) or [Equation 2](#) to calculate the MANTISSA. Next, use [Equation 3](#) or [Equation 4](#) to calculate the ADC\_CODES. Finally, use [Equation 5](#) to calculate the lux.

$$\text{MANTISSA} = (\text{RESULT\_MSB} \ll 8) + \text{RESULT\_LSB} \quad (1)$$

or

$$\text{MANTISSA} = (\text{RESULT\_MSB} \times 2^8) + \text{RESULT\_LSB} \quad (2)$$

where:

- The RESULT\_MSB, RESULT\_LSB, and EXPONENT bits are parts of the output register

The RESULT\_MSB register carries the most significant 12 bits of the MANTISSA, and the RESULT\_LSB register carries the least significant eight bits of the MANTISSA. Use the previous equations to get the 20-bit MANTISSA number. The four EXPONENT bits are directly read from the register.

After the EXPONENT and MANTISSA portions are calculated, use [Equation 3](#) or [Equation 4](#) to calculate the linearized ADC\_CODES.

$$\text{ADC\_CODES} = (\text{MANTISSA} \ll E) \quad (3)$$

or

$$\text{ADC\_CODES} = (\text{MANTISSA} \times 2^E) \quad (4)$$

The maximum value for register E is 8, thus the ADC\_CODES is effectively a 28-bit number. As shown in [Equation 5](#), the semi-logarithmic numbers are converted to a linear ADC\_CODES representation, which is simple to convert to lux.

$$\text{lux} = \text{ADC\_CODES} \times 585\text{E-}6 \quad (5)$$

The MANTISSA and ADC\_CODES are large numbers with 20 and 28 bits required to represent them. While developing firmware or software for these calculations, allocating appropriate data types to prevent data overflow is important. Some explicit typecasting to a larger data type is recommended, such as 32-bit representation before a left-shift operation (<<).

### 6.4.6 Threshold Detection Calculations

The [THRESHOLD\\_H\\_RESULT](#) and [THRESHOLD\\_L\\_RESULT](#) threshold result registers are 12 bits, whereas the [THRESHOLD\\_H\\_EXPONENT](#) and [THRESHOLD\\_L\\_EXPONENT](#) threshold exponent registers are four bits. The threshold is compared at linear ADC\_CODES, as given by the following equations. Therefore, the threshold registers are padded with zeros internally to compare with the ADC\_CODES.

$$\text{ADC\_CODES\_TH} = \text{THRESHOLD\_H\_RESULT} \ll (8 + \text{THRESHOLD\_H\_EXPONENT}) \quad (6)$$

or

$$\text{ADC\_CODES\_TH} = \text{THRESHOLD\_H\_RESULT} \times 2^{(8 + \text{THRESHOLD\_H\_EXPONENT})} \quad (7)$$

and

$$\text{ADC\_CODES\_TL} = \text{THRESHOLD\_L\_RESULT} \ll (8 + \text{THRESHOLD\_L\_EXPONENT}) \quad (8)$$

or

$$\text{ADC\_CODES\_TL} = \text{THRESHOLD\_L\_RESULT} \times 2^{(8 + \text{THRESHOLD\_L\_EXPONENT})} \quad (9)$$

Threshold are then compared as given in the following equations to detect *fault events*.

$$\text{If } \text{ADC\_CODES} < \text{ADC\_CODES\_TL} \text{ a } \textit{fault low} \text{ is detected} \quad (10)$$

and

$$\text{If } \text{ADC\_CODES} > \text{ADC\_CODES\_TH} \text{ a } \textit{fault high} \text{ is detected} \quad (11)$$

Based on the FAULT\_COUNT register setting, with consecutive *fault high* or *fault low* events, the respective FLAG\_H and FLAG\_L registers are set. See the [Interrupt Modes of Operation](#) section for more information. Understanding the relation between the THRESHOLD\_H\_EXPONENT, THRESHOLD\_H\_RESULT, THRESHOLD\_L\_EXPONENT, and THRESHOLD\_L\_RESULT register bits and the output registers is important to set the appropriate threshold based on application needs.

### 6.4.7 Light Resolution

The effective resolution of the OPT4041 is dependent on both the conversion time setting and the full-scale light range. Although the LSB resolution of the linear ADC\_CODES does not change, the effective or useful resolution of the device is dependent (as per [表 6-5](#)) on the conversion time setting and the full-scale range. In conversion times where the effective resolution is lower, the LSBs are padded with 0.

**表 6-5. Channel 0 Resolution Table**

| CONVERSION TIME REGISTER | CONVERSION TIME | MANTISSA EFFECTIVE BITS | EXPONENT                                     |         |         |         |         |         |         |         |         |
|--------------------------|-----------------|-------------------------|--|---------|---------|---------|---------|---------|---------|---------|---------|
|                          |                 |                         | 0  | 1       | 2       | 3       | 4       | 5       | 6       | 7       | 8       |
|                          |                 |                         | FULL-SCALE LUX (Effective Resolution in Lux) |         |         |         |         |         |         |         |         |
|                          |                 |                         | 613  | 1227    | 2454    | 4907    | 9815    | 19629   | 39259   | 78517   | 157034  |
| 0                        | 600µs           | 9                       | 1.198  | 2.396   | 4.792   | 9.585   | 19.17   | 38.34   | 76.68   | 153.35  | 306.71  |
| 1                        | 1ms             | 10                      | 599.04m                                      | 1.198   | 2.396   | 4.792   | 9.585   | 19.17   | 38.34   | 76.68   | 153.35  |
| 2                        | 1.8ms           | 11                      | 299.52m                                      | 599.04m | 1.198   | 2.396   | 4.792   | 9.585   | 19.17   | 38.34   | 76.68   |
| 3                        | 3.4ms           | 12                      | 149.76m                                      | 299.52m | 599.04m | 1.198   | 2.396   | 4.792   | 9.585   | 19.17   | 38.34   |
| 4                        | 6.5ms           | 13                      | 74.88m                                       | 149.76m | 299.52m | 599.04m | 1.198   | 2.396   | 4.792   | 9.585   | 19.17   |
| 5                        | 12.7ms          | 14                      | 37.44m                                       | 74.88m  | 149.76m | 299.52m | 599.04m | 1.198   | 2.396   | 4.792   | 9.585   |
| 6                        | 25ms            | 15                      | 18.72m                                       | 37.44m  | 74.88m  | 149.76m | 299.52m | 599.04m | 1.198   | 2.396   | 4.792   |
| 7                        | 50ms            | 16                      | 9.36m  | 18.72m  | 37.44m  | 74.88m  | 149.76m | 299.52m | 599.04m | 1.198   | 2.396   |
| 8                        | 100ms           | 17                      | 4.86m  | 9.36m   | 18.72m  | 37.44m  | 74.88m  | 149.76m | 299.52m | 599.04m | 1.198   |
| 9                        | 200ms           | 18                      | 2.34m  | 4.86m   | 9.36m   | 18.72m  | 37.44m  | 74.88m  | 149.76m | 299.52m | 599.04m |
| 10                       | 400ms           | 19                      | 1.17m  | 2.34m   | 4.86m   | 9.36m   | 18.72m  | 37.44m  | 74.88m  | 149.76m | 299.52m |
| 11                       | 800ms           | 20                      | 0.585m                                       | 1.17m   | 2.34m   | 4.86m   | 9.36m   | 18.72m  | 37.44m  | 74.88m  | 149.76m |

**表 6-6. Channel 1 Resolution Table**

| CONVERSION TIME REGISTER | CONVERSION TIME | MANTISSA EFFECTIVE BITS | EXPONENT                       |        |         |         |         |          |          |
|--------------------------|-----------------|-------------------------|--------------------------------|--------|---------|---------|---------|----------|----------|
|                          |                 |                         | 0                              | 1      | 2       | 3       | 4       | 5        | 6        |
|                          |                 |                         | FULL-SCALE IRRADIANCE (µW/cm²) |        |         |         |         |          |          |
|                          |                 |                         | 202                            | 403    | 807     | 1610    | 3230    | 6450     | 12910    |
|                          |                 |                         | Effective Resolution (nW/cm²)  |        |         |         |         |          |          |
| 0                        | 600µs           | 9                       | 393.83                         | 787.66 | 1575.32 | 3150.64 | 6301.29 | 12602.57 | 25205.15 |

表 6-6. Channel 1 Resolution Table (続き)

| CONVERSION TIME REGISTER                         | CONVERSION TIME | MANTISSA EFFECTIVE BITS | EXPONENT  |        |        |         |         |         |          |
|--|-----------------|-------------------------|---|--------|--------|---------|---------|---------|----------|
|  |                 |                         | 0   | 1      | 2      | 3       | 4       | 5       | 6        |
|  |                 |                         | FULL-SCALE IRRADIANCE ( $\mu\text{W}/\text{cm}^2$ ) |        |        |         |         |         |          |
|  |                 |                         | 202   | 403    | 807    | 1610    | 3230    | 6450    | 12910    |
| Effective Resolution ( $\text{nW}/\text{cm}^2$ ) |                 |                         |   |        |        |         |         |         |          |
| 1  | 1ms             | 10                      | 196.92  | 393.83 | 787.66 | 1575.32 | 3150.64 | 6301.29 | 12602.57 |
| 2  | 1.8ms           | 11                      | 98.46   | 196.92 | 393.83 | 787.66  | 1575.32 | 3150.64 | 6301.29  |
| 3  | 3.4ms           | 12                      | 49.23   | 98.46  | 196.92 | 393.83  | 787.66  | 1575.32 | 3150.64  |
| 4  | 6.5ms           | 13                      | 24.61   | 49.23  | 98.46  | 196.92  | 393.83  | 787.66  | 1575.32  |
| 5  | 12.7ms          | 14                      | 12.31   | 24.61  | 49.23  | 98.46   | 196.92  | 393.83  | 787.66   |
| 6  | 25ms            | 15                      | 6.15  | 12.31  | 24.61  | 49.23   | 98.46   | 196.92  | 393.83   |
| 7  | 50ms            | 16                      | 3.08  | 6.15   | 12.31  | 24.61   | 49.23   | 98.46   | 196.92   |
| 8  | 100ms           | 17                      | 1.54  | 3.08   | 6.15   | 12.31   | 24.61   | 49.23   | 98.46    |
| 9  | 200ms           | 18                      | 0.769   | 1.54   | 3.08   | 6.15    | 12.31   | 24.61   | 49.23    |
| 10   | 400ms           | 19                      | 0.385   | 0.769  | 1.54   | 3.08    | 6.15    | 12.31   | 24.61    |
| 11   | 800ms           | 20                      | 0.192   | 0.385  | 0.769  | 1.54    | 3.08    | 6.15    | 12.31    |

## 6.5 Programming

The OPT4041 supports the transmission protocol for standard mode (up to 100kHz), fast mode (up to 400kHz), and high-speed mode (up to 2.6MHz). Fast and standard modes are described as the default protocol, referred to as F/S. High-speed mode is described in the [High-Speed I<sup>2</sup>C Mode](#) section.

### 6.5.1 I<sup>2</sup>C Bus Overview

The OPT4041 offers compatibility with both I<sup>2</sup>C and SMBus interfaces. The I<sup>2</sup>C and SMBus protocols are essentially compatible with one another. The I<sup>2</sup>C interface is used throughout this document as the primary example with the SMBus protocol specified only when a difference between the two protocols is discussed.

The device is connected to the bus with two pins: an SCL clock input pin and an SDA open-drain bidirectional data pin. The bus must have a controller device that generates the serial clock (SCL), controls the bus access, and generates start and stop conditions. To address a specific device, the controller initiates a start condition by pulling the data signal line (SDA) from a high logic level to a low logic level while SCL is high. All targets on the bus shift in the target address byte on the SCL rising edge, with the last bit indicating whether a read or write operation is intended. During the ninth clock pulse, the target being addressed responds to the controller by generating an acknowledge bit by pulling SDA low.

Data transfer is then initiated and eight bits of data are sent, followed by an acknowledge bit. During data transfer, SDA must remain stable while SCL is high. Any change in SDA while SCL is high is interpreted as a start or stop condition. When all data are transferred, the controller generates a stop condition, indicated by pulling SDA from low to high while SCL is high. The device includes a 28ms timeout on the I<sup>2</sup>C interface to prevent locking up the bus. If the SCL line is held low for this duration of time, the bus state machine is reset.

#### 6.5.1.1 Serial Bus Address

To communicate with the OPT4041, the controller must first initiate an I<sup>2</sup>C start command. Then, the controller must address target devices through a target address byte. The target address byte consists of a seven bit address and a direction bit that indicates whether the action is to be a read or write operation.

Four I<sup>2</sup>C addresses are possible by connecting the ADDR pin to one of four pins: GND, VDD, SDA, or SCL. [表 6-7](#) summarizes the possible addresses with the corresponding ADDR pin configuration. The state of the ADDR pin is sampled on every bus communication and must be driven or connected to the desired level before any activity on the interface occurs.

表 6-7. ADDR Pin Addresses

| ADDR PIN CONNECTION | DEVICE I <sup>2</sup> C ADDRESS |
|---------------------|---------------------------------|
| GND                 | 1000100                         |
| VDD                 | 1000101                         |
| SDA                 | 1000110                         |
| SCL                 | 1000111                         |

### 6.5.1.2 Serial Interface

The OPT4041 operates as a target device on both the I<sup>2</sup>C bus and SMBus. Connections to the bus are made through the SCL clock input line and the SDA open-drain I/O line. The device supports the transmission protocol for standard mode (up to 100kHz), fast mode (up to 400kHz), and high-speed mode (up to 2.6MHz). All data bytes are transmitted most significant bits first.

The SDA and SCL pins feature integrated spike-suppression filters and Schmitt triggers to minimize the effects of input spikes and bus noise.

### 6.5.2 Writing and Reading

Accessing a specific register on the OPT4041 is accomplished by writing the appropriate register address during the I<sup>2</sup>C transaction sequence. See the [Register Maps](#) for a complete list of registers and the corresponding register addresses. The value for the register address (as shown in 図 6-4) is the first byte transferred after the target address byte with the R/W bit low.



図 6-4. Setting the I<sup>2</sup>C Register Address

Writing to a register begins with the first byte transmitted by the controller. This byte is the target address with the R/W bit low. The device then acknowledges receipt of a valid address. The next byte transmitted by the controller is the address of the register that data are to be written to. The next two bytes are written to the register addressed by the register address. The device acknowledges receipt of each data byte. The controller can terminate the data transfer by generating a start or stop condition.

When reading from the device, the last value stored in the register address by a write operation determines which register is read during a read operation. To change the register address for a read operation, a new partial I<sup>2</sup>C write transaction must be initiated. This partial write is accomplished by issuing a target address byte with the R/W bit low, followed by the register address byte and a stop command. The controller then generates a start condition and sends the target address byte with the R/W bit high to initiate the read command. The next byte is transmitted by the target and is the most significant byte of the register indicated by the register address. This byte is followed by an acknowledge from the controller, then the target transmits the least significant byte. The controller acknowledges receipt of the data byte. The controller can terminate the data transfer by generating a not-acknowledge after receiving any data byte, or by generating a start or stop condition. If repeated reads from the same register are desired, continually sending the register address bytes is not necessary. The device retains the register address until that number is changed by the next write operation.

Figure 6-5 and Figure 6-6 show the write and read operation timing diagrams, respectively. Register bytes are sent most significant byte first, followed by the least significant byte.

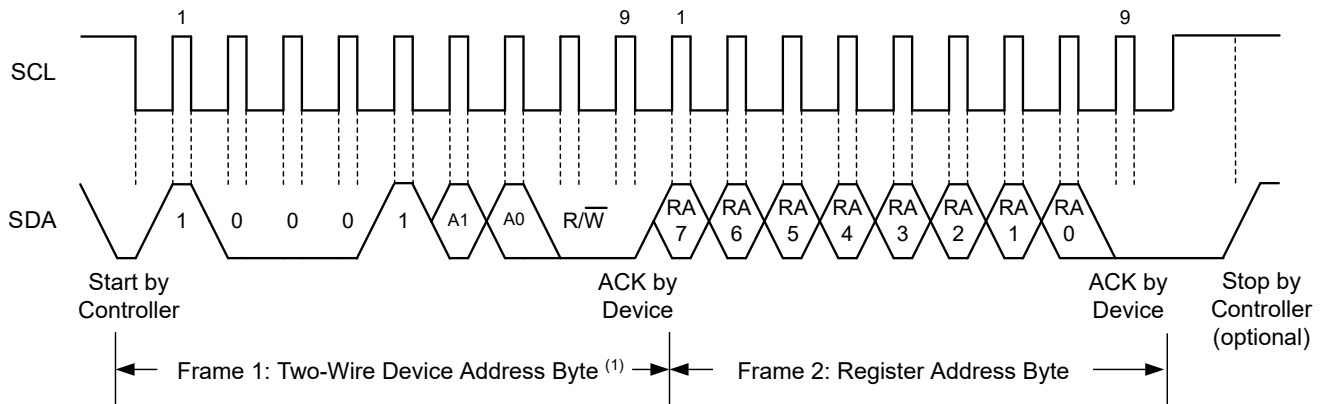
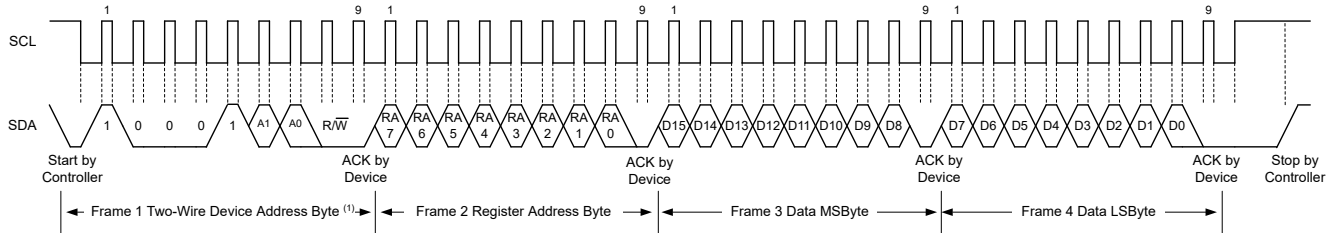
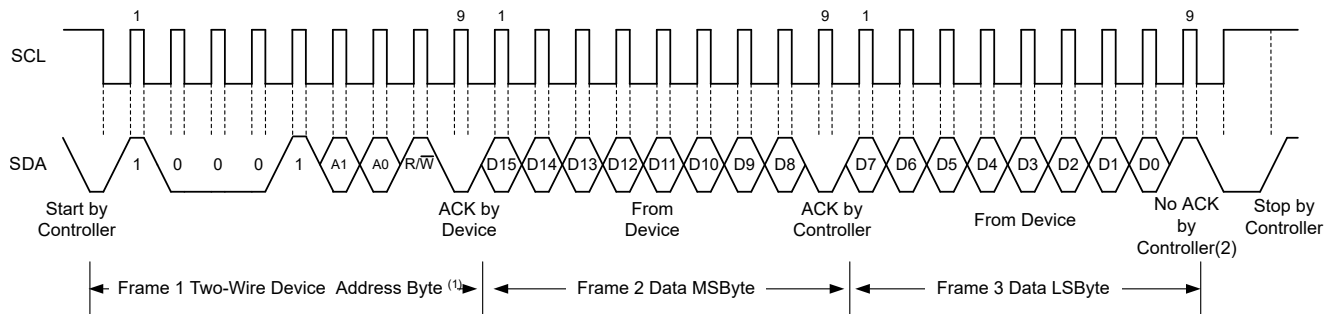

Figure 6-5. I<sup>2</sup>C Write Example



A. An ACK by the controller can also be sent.

Figure 6-6. I<sup>2</sup>C Read Example

### 6.5.2.1 High-Speed I<sup>2</sup>C Mode

When the bus is idle, both the SDA and SCL lines are pulled high by the pullup resistors or active pullup devices. The controller generates a start condition followed by a valid serial byte containing the high-speed (HS) controller code 0000 1XXXb. This transmission is made in either standard mode or fast mode (up to 400kHz). The device does not acknowledge the HS controller code but does recognize the code and switches the internal filters to support a 2.6MHz operation.

The controller then generates a repeated start condition (a repeated start condition has the same timing as the start condition). After this repeated start condition, the protocol is the same as F/S mode, except that transmission speeds up to 2.6MHz are allowed. Instead of using a stop condition, use repeated start conditions to secure the bus in HS mode. A stop condition ends the HS mode and switches all internal filters of the device to support the F/S mode.

### 6.5.2.2 Burst Read Mode

The OPT4041 supports I<sup>2</sup>C burst read mode, which helps minimize the number of transactions on the bus for efficient data transfer from the device to the controller.

Before considering the burst mode, a regular I<sup>2</sup>C read transaction involves an I<sup>2</sup>C write operation to the device read pointer, followed by the actual I<sup>2</sup>C read operation. If regular I<sup>2</sup>C read transactions are performed when reading from the output registers and FIFO registers, which are in continuous locations, then the register pointer is written every two bytes and this process takes up several clock cycles. With the burst mode enabled, the read pointer address is auto incremented after every register read (two bytes), eliminating the need to write operations to set the pointer for subsequent register reads.

Set the I2C\_BURST register to enable burst mode. When a stop command is issued, the pointer resets to the original register address before the auto-increments. Figure 6-7 shows a diagram of the I<sup>2</sup>C write, single read, and burst mode read operation.

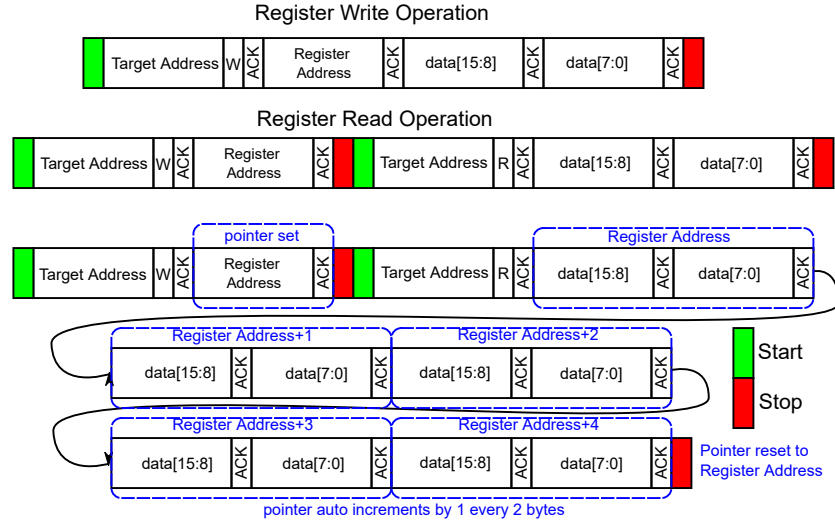

**6-7. I<sup>2</sup>C Operations**

### 6.5.2.3 General-Call Reset Command

The I<sup>2</sup>C general-call reset allows the host controller in one command to reset all devices on the bus that respond to the general-call reset command. Write to the I<sup>2</sup>C address 0 (0000 0000b) to initiate the general call. The reset command is initiated when the subsequent second address byte is 06h (0000 0110b). With this transaction, the device issues an acknowledge bit and sets all registers to the power-on-reset default condition.

## 7 Register Maps

 7-1. ALL Register Map

| ADD | D15                  | D14 | D13   | D12 | D11 | D10 | D9                   | D8 | D7                            | D6 | D5             | D4 | D3           | D2      | D1          | D0 |
|-----|----------------------|-----|-------|-----|-----|-----|----------------------|----|-------------------------------|----|----------------|----|--------------|---------|-------------|----|
| 00h | EXPONENT_CH0         |     |       |     |     |     | RESULT_MSB_CH0       |    |                               |    |                |    |              |         |             |    |
| 01h | RESULT_LSB_CH0       |     |       |     |     |     | COUNTER_CH0          |    |                               |    |                |    | CRC_CH0      |         |             |    |
| 02h | EXPONENT_CH1         |     |       |     |     |     | RESULT_MSB_CH1       |    |                               |    |                |    |              |         |             |    |
| 03h | RESULT_LSB_CH1       |     |       |     |     |     | COUNTER_CH1          |    |                               |    |                |    | CRC_CH1      |         |             |    |
| 04h | EXPONENT_FIFO_CH0    |     |       |     |     |     | RESULT_MSB_FIFO_CH0  |    |                               |    |                |    |              |         |             |    |
| 05h | RESULT_LSB_FIFO_CH0  |     |       |     |     |     | COUNTER_FIFO_CH0     |    |                               |    |                |    | CRC_FIFO_CH0 |         |             |    |
| 06h | EXPONENT_FIFO_CH1    |     |       |     |     |     | RESULT_MSB_FIFO_CH1  |    |                               |    |                |    |              |         |             |    |
| 07h | RESULT_LSB_FIFO_CH1  |     |       |     |     |     | COUNTER_FIFO_CH1     |    |                               |    |                |    | CRC_FIFO_CH1 |         |             |    |
| 08h | THRESHOLD_L_EXPONENT |     |       |     |     |     | THRESHOLD_L_RESULT   |    |                               |    |                |    |              |         |             |    |
| 09h | THRESHOLD_H_EXPONENT |     |       |     |     |     | THRESHOLD_H_RESULT   |    |                               |    |                |    |              |         |             |    |
| 0Ah | QWAKE                | 0   | RANGE |     |     |     | CONVERSION_TIME      |    |                               |    | OPERATING_MODE |    | LATCH        | INT_POL | FAULT_COUNT |    |
| 0Bh | 128                  |     |       |     |     |     | THRESHOL<br>D_CH_SEL |    | INT_DIR                       |    | INT_CFG        |    |              | 0       | I2C_BURST   |    |
| 0Ch | 0                    |     |       |     |     |     | OVERLOAD<br>_FLAG    |    | CONVERSI<br>ON_READY<br>_FLAG |    | FLAG_H         |    | FLAG_L       |         |             |    |
| 11h | 0                    |     | DIDL  |     |     |     | DIDH                 |    |                               |    |                |    |              |         |             |    |

## 7.1 Register Descriptions

### 7.1.1 Register 0h (offset = 0h) [reset = 0h]

#### ☒ 7-2. Register 0h

|                |    |    |    |                |    |   |   |
|----------------|----|----|----|----------------|----|---|---|
| 15             | 14 | 13 | 12 | 11             | 10 | 9 | 8 |
| EXPONENT_CH0   |    |    |    | RESULT_MSB_CH0 |    |   |   |
| R-0h           |    |    |    | R-0h           |    |   |   |
| 7              | 6  | 5  | 4  | 3              | 2  | 1 | 0 |
| RESULT_MSB_CH0 |    |    |    |                |    |   |   |
| R-0h           |    |    |    |                |    |   |   |

LEGEND: R/W = Read/Write; W = Write only; -n = value after reset

#### ☒ 7-3. Register 00 Field Descriptions

| Bit   | Field          | Type | Reset | Description   |
|-------|----------------|------|-------|---|
| 15-12 | EXPONENT_CH0   | R    | 0h    | EXPONENT output CH0. Determines the full-scale range of the light measurement for the channel. Used as a scaling factor for lux calculation.          |
| 11-0  | RESULT_MSB_CH0 | R    | 0h    | Result register MSB (most significant bits) CH0. Used to calculate the MANTISSA representing light level within a given EXPONENT or full-scale range. |

### 7.1.2 Register 1h (offset = 1h) [reset = 0h]

#### ☒ 7-4. Register 1h

|                |    |    |    |         |    |   |   |
|----------------|----|----|----|---------|----|---|---|
| 15             | 14 | 13 | 12 | 11      | 10 | 9 | 8 |
| RESULT_LSB_CH0 |    |    |    |         |    |   |   |
| R-0h           |    |    |    |         |    |   |   |
| 7              | 6  | 5  | 4  | 3       | 2  | 1 | 0 |
| COUNTER_CH0    |    |    |    | CRC_CH0 |    |   |   |
| R-0h           |    |    |    | R-0h    |    |   |   |

LEGEND: R/W = Read/Write; W = Write only; -n = value after reset

#### ☒ 7-5. Register 01 Field Descriptions

| Bit  | Field          | Type | Reset | Description   |
|------|----------------|------|-------|---|
| 15-8 | RESULT_LSB_CH0 | R    | 0h    | Result register LSB (least significant bits) CH0. Used to calculate MANTISSA representing light level within a given EXPONENT or full-scale range.  |
| 7-4  | COUNTER_CH0    | R    | 0h    | Sample counter CH0. Rolling counter that increments for every conversion.   |
| 3-0  | CRC_CH0        | R    | 0h    | CRC bits CH0.<br>$R[19:0] = \text{MANTISSA} = ((\text{RESULT\_MSB} \ll 8) + \text{RESULT\_LSB})$<br>$X[0] = \text{XOR}(E[3:0], R[19:0], C[3:0])$ XOR of all bits<br>$X[1] = \text{XOR}(C[1], C[3], R[1], R[3], R[5], R[7], R[9], R[11], R[13], R[15], R[17], R[19], E[1], E[3])$<br>$X[2] = \text{XOR}(C[3], R[3], R[7], R[11], R[15], R[19], E[3])$<br>$X[3] = \text{XOR}(R[3], R[11], R[19])$ |

### 7.1.3 Register 2h (offset = 2h) [reset = 0h]

☒ 7-6. Register 2h

|                |    |    |    |                |    |   |   |
|----------------|----|----|----|----------------|----|---|---|
| 15             | 14 | 13 | 12 | 11             | 10 | 9 | 8 |
| EXPONENT_CH1   |    |    |    | RESULT_MSB_CH1 |    |   |   |
| R-0h           |    |    |    | R-0h           |    |   |   |
| 7              | 6  | 5  | 4  | 3              | 2  | 1 | 0 |
| RESULT_MSB_CH1 |    |    |    |                |    |   |   |
| R-0h           |    |    |    |                |    |   |   |

LEGEND: R/W = Read/Write; W = Write only; -n = value after reset

☒ 7-7. Register 02 Field Descriptions

| Bit   | Field              | Type | Reset | Description   |
|-------|--------------------|------|-------|---|
| 15-12 | EXPONENT_CH1       | R    | 0h    | EXPONENT output CH1. Determines the full-scale range of the light measurement for the channel. Used as a scaling factor for lux calculation.          |
| 11-0  | RESULT_MSB_C<br>H1 | R    | 0h    | Result register MSB (most significant bits) CH1. Used to calculate the MANTISSA representing light level within a given EXPONENT or full-scale range. |

### 7.1.4 Register 3h (offset = 3h) [reset = 0h]

☒ 7-8. Register 3h

|                |    |    |    |         |    |   |   |
|----------------|----|----|----|---------|----|---|---|
| 15             | 14 | 13 | 12 | 11      | 10 | 9 | 8 |
| RESULT_LSB_CH1 |    |    |    |         |    |   |   |
| R-0h           |    |    |    |         |    |   |   |
| 7              | 6  | 5  | 4  | 3       | 2  | 1 | 0 |
| COUNTER_CH1    |    |    |    | CRC_CH1 |    |   |   |
| R-0h           |    |    |    | R-0h    |    |   |   |

LEGEND: R/W = Read/Write; W = Write only; -n = value after reset

☒ 7-9. Register 03 Field Descriptions

| Bit  | Field              | Type | Reset | Description   |
|------|--------------------|------|-------|---|
| 15-8 | RESULT_LSB_C<br>H1 | R    | 0h    | Result register LSB (least significant bits) CH1. Used to calculate MANTISSA representing light level within a given EXPONENT or full-scale range.  |
| 7-4  | COUNTER_CH1        | R    | 0h    | Sample counter CH1. Rolling counter that increments for every conversion.   |
| 3-0  | CRC_CH1            | R    | 0h    | CRC bits CH1.<br>$R[19:0] = \text{MANTISSA} = ((\text{RESULT\_MSB} \ll 8) + \text{RESULT\_LSB})$<br>$X[0] = \text{XOR}(E[3:0], R[19:0], C[3:0])$ XOR of all bits<br>$X[1] = \text{XOR}(C[1], C[3], R[1], R[3], R[5], R[7], R[9], R[11], R[13], R[15], R[17], R[19], E[1], E[3])$<br>$X[2] = \text{XOR}(C[3], R[3], R[7], R[11], R[15], R[19], E[3])$<br>$X[3] = \text{XOR}(R[3], R[11], R[19])$ |

### 7.1.5 Register 4h (offset = 4h) [reset = 0h]

**7-10. Register 4h**

|                     |    |    |    |                     |    |   |   |
|---------------------|----|----|----|---------------------|----|---|---|
| 15                  | 14 | 13 | 12 | 11                  | 10 | 9 | 8 |
| EXPONENT_FIFO_CH0   |    |    |    | RESULT_MSB_FIFO_CH0 |    |   |   |
| R-0h                |    |    |    | R-0h                |    |   |   |
| 7                   | 6  | 5  | 4  | 3                   | 2  | 1 | 0 |
| RESULT_MSB_FIFO_CH0 |    |    |    |                     |    |   |   |
| R-0h                |    |    |    |                     |    |   |   |

LEGEND: R/W = Read/Write; W = Write only; -n = value after reset

**7-11. Register 04 Field Descriptions**

| Bit   | Field               | Type | Reset | Description                       |
|-------|---------------------|------|-------|-----------------------------------|
| 15-12 | EXPONENT_FIFO_CH0   | R    | 0h    | EXPONENT register from FIFO CH0   |
| 11-0  | RESULT_MSB_FIFO_CH0 | R    | 0h    | RESULT_MSB Register from FIFO CH0 |

### 7.1.6 Register 5h (offset = 5h) [reset = 0h]

**7-12. Register 5h**

|                     |    |    |    |              |    |   |   |
|---------------------|----|----|----|--------------|----|---|---|
| 15                  | 14 | 13 | 12 | 11           | 10 | 9 | 8 |
| RESULT_LSB_FIFO_CH0 |    |    |    |              |    |   |   |
| R-0h                |    |    |    |              |    |   |   |
| 7                   | 6  | 5  | 4  | 3            | 2  | 1 | 0 |
| COUNTER_FIFO_CH0    |    |    |    | CRC_FIFO_CH0 |    |   |   |
| R-0h                |    |    |    | R-0h         |    |   |   |

LEGEND: R/W = Read/Write; W = Write only; -n = value after reset

**7-13. Register 05 Field Descriptions**

| Bit  | Field               | Type | Reset | Description                       |
|------|---------------------|------|-------|-----------------------------------|
| 15-8 | RESULT_LSB_FIFO_CH0 | R    | 0h    | RESULT_LSB register from FIFO CH0 |
| 7-4  | COUNTER_FIFO_CH0    | R    | 0h    | COUNTER register from FIFO CH0    |
| 3-0  | CRC_FIFO_CH0        | R    | 0h    | CRC register from FIFO CH0        |

### 7.1.7 Register 6h (offset = 6h) [reset = 0h]

☒ 7-14. Register 6h

|                     |    |    |    |                     |    |   |   |
|---------------------|----|----|----|---------------------|----|---|---|
| 15                  | 14 | 13 | 12 | 11                  | 10 | 9 | 8 |
| EXPONENT_FIFO_CH1   |    |    |    | RESULT_MSB_FIFO_CH1 |    |   |   |
| R-0h                |    |    |    | R-0h                |    |   |   |
| 7                   | 6  | 5  | 4  | 3                   | 2  | 1 | 0 |
| RESULT_MSB_FIFO_CH1 |    |    |    |                     |    |   |   |
| R-0h                |    |    |    |                     |    |   |   |

LEGEND: R/W = Read/Write; W = Write only; -n = value after reset

☒ 7-15. Register 06 Field Descriptions

| Bit   | Field               | Type | Reset | Description                       |
|-------|---------------------|------|-------|-----------------------------------|
| 15-12 | EXPONENT_FIFO_CH1   | R    | 0h    | EXPONENT register from FIFO CH1   |
| 11-0  | RESULT_MSB_FIFO_CH1 | R    | 0h    | RESULT_MSB register from FIFO CH1 |

### 7.1.8 Register 7h (offset = 7h) [reset = 0h]

☒ 7-16. Register 7h

|                     |    |    |    |              |    |   |   |
|---------------------|----|----|----|--------------|----|---|---|
| 15                  | 14 | 13 | 12 | 11           | 10 | 9 | 8 |
| RESULT_LSB_FIFO_CH1 |    |    |    |              |    |   |   |
| R-0h                |    |    |    |              |    |   |   |
| 7                   | 6  | 5  | 4  | 3            | 2  | 1 | 0 |
| COUNTER_FIFO_CH1    |    |    |    | CRC_FIFO_CH1 |    |   |   |
| R-0h                |    |    |    | R-0h         |    |   |   |

LEGEND: R/W = Read/Write; W = Write only; -n = value after reset

☒ 7-17. Register 07 Field Descriptions

| Bit  | Field               | Type | Reset | Description                       |
|------|---------------------|------|-------|-----------------------------------|
| 15-8 | RESULT_LSB_FIFO_CH1 | R    | 0h    | RESULT_LSB register from FIFO CH1 |
| 7-4  | COUNTER_FIFO_CH1    | R    | 0h    | COUNTER register from FIFO CH1    |
| 3-0  | CRC_FIFO_CH1        | R    | 0h    | CRC register from FIFO CH1        |

### 7.1.9 Register 8h (offset = 8h) [reset = 0h]

☒ 7-18. Register 8h

|                      |    |    |    |                    |    |   |   |
|----------------------|----|----|----|--------------------|----|---|---|
| 15                   | 14 | 13 | 12 | 11                 | 10 | 9 | 8 |
| THRESHOLD_L_EXPONENT |    |    |    | THRESHOLD_L_RESULT |    |   |   |
| R/W-0h               |    |    |    | R/W-0h             |    |   |   |
| 7                    | 6  | 5  | 4  | 3                  | 2  | 1 | 0 |
| THRESHOLD_L_RESULT   |    |    |    |                    |    |   |   |
| R/W-0h               |    |    |    |                    |    |   |   |

LEGEND: R/W = Read/Write; W = Write only; -n = value after reset

☒ 7-19. Register 08 Field Descriptions

| Bit   | Field                | Type | Reset | Description                     |
|-------|----------------------|------|-------|---------------------------------|
| 15-12 | THRESHOLD_L_EXPONENT | R/W  | 0h    | Threshold low register exponent |
| 11-0  | THRESHOLD_L_RESULT   | R/W  | 0h    | Threshold low register result   |

### 7.1.10 Register 9h (offset = 9h) [reset = BFFFh]

☒ 7-20. Register 9h

|                      |    |    |    |                    |    |   |   |
|----------------------|----|----|----|--------------------|----|---|---|
| 15                   | 14 | 13 | 12 | 11                 | 10 | 9 | 8 |
| THRESHOLD_H_EXPONENT |    |    |    | THRESHOLD_H_RESULT |    |   |   |
| R/W-Bh               |    |    |    | R/W-Fh             |    |   |   |
| 7                    | 6  | 5  | 4  | 3                  | 2  | 1 | 0 |
| THRESHOLD_H_RESULT   |    |    |    |                    |    |   |   |
| R/W-FFh              |    |    |    |                    |    |   |   |

LEGEND: R/W = Read/Write; W = Write only; -n = value after reset

☒ 7-21. Register 09 Field Descriptions

| Bit   | Field                | Type | Reset | Description                      |
|-------|----------------------|------|-------|----------------------------------|
| 15-12 | THRESHOLD_H_EXPONENT | R/W  | Bh    | Threshold high register exponent |
| 11-0  | THRESHOLD_H_RESULT   | R/W  | FFFh  | Threshold high register result   |

### 7.1.11 Register Ah (offset = Ah) [reset = 3208h]

☒ 7-22. Register Ah

|                 |        |                |    |        |         |                 |   |
|-----------------|--------|----------------|----|--------|---------|-----------------|---|
| 15              | 14     | 13             | 12 | 11     | 10      | 9               | 8 |
| QWAKE           | 0      | RANGE          |    |        |         | CONVERSION_TIME |   |
| R/W-0h          | R/W-0h | R/W-Ch         |    |        |         | R/W-2h          |   |
| 7               | 6      | 5              | 4  | 3      | 2       | 1               | 0 |
| CONVERSION_TIME |        | OPERATING_MODE |    | LATCH  | INT_POL | FAULT_COUNT     |   |
| R/W-0h          |        | R/W-0h         |    | R/W-1h | R/W-0h  | R/W-0h          |   |

LEGEND: R/W = Read/Write; W = Write only; -n = value after reset

☒ 7-23. Register 0A Field Descriptions

| Bit   | Field           | Type | Reset | Description   |
|-------|-----------------|------|-------|---|
| 15-15 | QWAKE           | R/W  | 0h    | Quick wake-up from standby in one-shot mode by not powering down all circuits. Applicable only in one-shot mode and helps get out of standby mode faster with penalty in power consumption compared to full standby mode.   |
| 14-14 | 0               | R/W  | 0h    | Must read or write 0  |
| 13-10 | RANGE           | R/W  | Ch    | Controls the full-scale light level range of the device. The format of this register is same as the EXPONENT register for all values from 0 to 8. For CH0 and CH1 RANGE and corresponding EXPONENT values see <a href="#">セクション 6.4.3</a> .<br>Channel 0:<br>0 = 613 lux<br>1 = 1.2klux<br>2 = 2.5klux<br>3 = 4.9klux<br>4 = 9.8klux<br>5 = 19.6klux<br>6 = 39.3klux<br>7 = 78.5klux<br>8 = 157klux<br>12 = Auto-range<br>Channel 1:<br>0 = 0.202mW/cm <sup>2</sup><br>1 = 0.403mW/cm <sup>2</sup><br>2 = 0.807mW/cm <sup>2</sup><br>3 = 1.61mW/cm <sup>2</sup><br>4 = 3.23mW/cm <sup>2</sup><br>5 = 6.45mW/cm <sup>2</sup><br>6 = 12.91mW/cm <sup>2</sup><br>7 = 12.91mW/cm <sup>2</sup><br>8 = 12.91mW/cm <sup>2</sup><br>12 = Auto-range |
| 9-6   | CONVERSION_TIME | R/W  | 8h    | Controls the device conversion time<br>0 = 600μs<br>1 = 1ms<br>2 = 1.8ms<br>3 = 3.4ms<br>4 = 6.5ms<br>5 = 12.7ms<br>6 = 25ms<br>7 = 50ms<br>8 = 100ms<br>9 = 200ms<br>10 = 400ms<br>11 = 800ms  |

図 7-23. Register 0A Field Descriptions (続き)

| Bit | Field          | Type | Reset | Description   |
|-----|----------------|------|-------|---|
| 5-4 | OPERATING_MODE | R/W  | 0h    | Controls device mode of operation<br>0 = Power-down<br>1 = Forced auto-range one-shot<br>2 = One-shot<br>3 = Continuous   |
| 3-3 | LATCH          | R/W  | 1h    | Controls the functionality of the interrupt reporting mechanisms for the INT pin for the threshold detection logic.   |
| 2-2 | INT_POL        | R/W  | 0h    | Controls the polarity or active state of the INT pin.<br>0 = Active low<br>1 = Active high  |
| 1-0 | FAULT_COUNT    | R/W  | 0h    | Fault count register instructs the device as to how many consecutive fault events are required to trigger the threshold mechanisms: the flag high (FLAG_H) and the flag low (FLAG_L) registers.<br>0 = One fault count<br>1 = Two fault counts<br>2 = Four fault counts<br>3 = Eight fault counts |

### 7.1.12 Register Bh (offset = Bh) [reset = 8011h]

図 7-24. Register Bh

|        |        |                  |         |         |        |        |           |
|--------|--------|------------------|---------|---------|--------|--------|-----------|
| 15     | 14     | 13               | 12      | 11      | 10     | 9      | 8         |
| 1      | 0      | 0                | 0       | 0       | 0      | 0      | 0         |
| R/W-1h | R/W-0h | R/W-0h           | R/W-0h  | R/W-0h  | R/W-0h | R/W-0h | R/W-0h    |
| 7      | 6      | 5                | 4       | 3       | 2      | 1      | 0         |
| 0      | 0      | THRESHOLD_CH_SEL | INT_DIR | INT_CFG |        | 0      | I2C_BURST |
| R/W-0h | R/W-0h | R/W-0h           | R/W-1h  | R/W-0h  |        | R/W-0h | R/W-1h    |

LEGEND: R/W = Read/Write; W = Write only; -n = value after reset

図 7-25. Register 0B Field Descriptions

| Bit  | Field            | Type | Reset | Description   |
|------|------------------|------|-------|---|
| 15-6 | 128              | R/W  | 200h  | Must read or write 128  |
| 5-5  | THRESHOLD_CH_SEL | R/W  | 0h    | Channel select for threshold logic<br>0 = CH0 selected<br>1 = CH1 selected  |
| 4-4  | INT_DIR          | R/W  | 1h    | Determines the direction of the INT pin.<br>0 = Input<br>1 = Output   |
| 3-2  | INT_CFG          | R/W  | 0h    | Controls the output interrupt mechanism after end of conversion<br>0 = SMBus alert<br>1 = INT pin asserted after every conversion<br>2 = INT pin asserted after every two conversions<br>3 = INT pin asserted after every 4 conversions (FIFO full) |
| 1-1  | 0                | R/W  | 0h    | Must read or write 0  |
| 0-0  | I2C_BURST        | R/W  | 1h    | When set, enables I <sup>2</sup> C burst mode minimizing I <sup>2</sup> C read cycles by auto incrementing read register pointer by 1 after every register read.  |

### 7.1.13 Register Ch (offset = Ch) [reset = 0h]

**7-26. Register Ch**

|        |        |        |        |                   |                           |        |        |
|--------|--------|--------|--------|-------------------|---------------------------|--------|--------|
| 15     | 14     | 13     | 12     | 11                | 10                        | 9      | 8      |
| 0      | 0      | 0      | 0      | 0                 | 0                         | 0      | 0      |
| R/W-0h | R/W-0h | R/W-0h | R/W-0h | R/W-0h            | R/W-0h                    | R/W-0h | R/W-0h |
| 7      | 6      | 5      | 4      | 3                 | 2                         | 1      | 0      |
| 0      | 0      | 0      | 0      | OVERLOAD_F<br>LAG | CONVERSION<br>_READY_FLAG | FLAG_H | FLAG_L |
| R/W-0h | R/W-0h | R/W-0h | R/W-0h | R-0h              | R-0h                      | R-0h   | R-0h   |

LEGEND: R/W = Read/Write; W = Write only; -n = value after reset

**7-27. Register 0C Field Descriptions**

| Bit  | Field                     | Type | Reset | Description   |
|------|---------------------------|------|-------|---|
| 15-4 | 0                         | R/W  | 0h    | Must read or write 0  |
| 3-3  | OVERLOAD_FL<br>AG         | R    | 0h    | Indicates when an overflow condition occurs in the data conversion process, typically because the light illuminating the device exceeds the full-scale range.   |
| 2-2  | CONVERSION_R<br>EADY_FLAG | R    | 0h    | Conversion-ready flag indicates when a conversion completes. The flag is set to 1 at the end of a conversion and is cleared (set to 0) when register address 0xC is either read or written with any non-zero value.<br>0 = Conversion in progress<br>1 = Conversion is complete   |
| 1-1  | FLAG_H                    | R    | 0h    | Flag high register identifies that the result of a conversion is the measurement of a specified level of interest. FLAG_H is set to 1 when the result is larger than the level in the THRESHOLD_H_EXPONENT and THRESHOLD_H_RESULT registers for a consecutive number of measurements defined by the FAULT_COUNT register. |
| 0-0  | FLAG_L                    | R    | 0h    | Flag low register identifies that the result of a measurement is smaller than a specified level of interest. FL is set to 1 when the result is smaller than the level in the THRESHOLD_LOW_EXPONENT and THRESHOLD_L_RESULT registers for a consecutive number of measurements defined by the FAULT_COUNT register.        |

**7.1.14 Register 11h (offset = 11h) [reset = 121h]**

**☒ 7-28. Register 11h**

|        |        |      |    |      |    |   |   |
|--------|--------|------|----|------|----|---|---|
| 15     | 14     | 13   | 12 | 11   | 10 | 9 | 8 |
| 0      | 0      | DIDL |    | DIDH |    |   |   |
| R/W-0h | R/W-0h | R-0h |    | R-2h |    |   |   |
| 7      | 6      | 5    | 4  | 3    | 2  | 1 | 0 |
| DIDH   |        |      |    |      |    |   |   |
| R-21h  |        |      |    |      |    |   |   |

LEGEND: R/W = Read/Write; W = Write only; -n = value after reset

**☒ 7-29. Register 11 Field Descriptions**

| Bit   | Field | Type | Reset | Description          |
|-------|-------|------|-------|----------------------|
| 15-14 | 0     | R/W  | 0h    | Must read or write 0 |
| 13-12 | DIDL  | R    | 0h    | Device ID L          |
| 11-0  | DIDH  | R    | 221h  | Device ID H          |

## 8 Application and Implementation

注

Information in the following applications sections is not part of the TI component specification, and TI does not warrant its accuracy or completeness. TI's customers are responsible for determining suitability of components for their purposes, as well as validating and testing their design implementation to confirm system functionality.

### 8.1 Application Information

Because ambient light sensors are used in a wide variety of applications that require precise measurement of light as perceived by the human eye, these sensors have a specialized filter that mimics the human eye. The following sections show crucial information about integrating the OPT4041 in applications.

### 8.2 Typical Application

#### 8.2.1 Electrical Interface

As shown in [Figure 8-1](#), the electrical interface is quite simple. Connect the OPT4041 I<sup>2</sup>C SDA and SCL pins to the same pins of an applications processor, microcontroller, or other digital processor. If that digital processor requires an interrupt resulting from an event of interest from the OPT4041, then connect the INT pin to either an interrupt or general-purpose I/O pin of the processor. There are multiple uses for this INT pin, including triggering a measurement on one-shot mode, signaling the system to wake up from low-power mode, processing other tasks while waiting for an ambient light event of interest, or alerting the processor that a sample is ready to be read. Connect pullup resistors between a power supply appropriate for digital communication and the SDA and SCL pins (because the pins have open-drain output structures). If the INT pin is used, connect a pullup resistor to the INT pin. A typical value for these pullup resistors is 10kΩ. The resistor choice can be optimized in conjunction to the bus capacitance to balance the system speed, power, noise immunity, and other requirements.

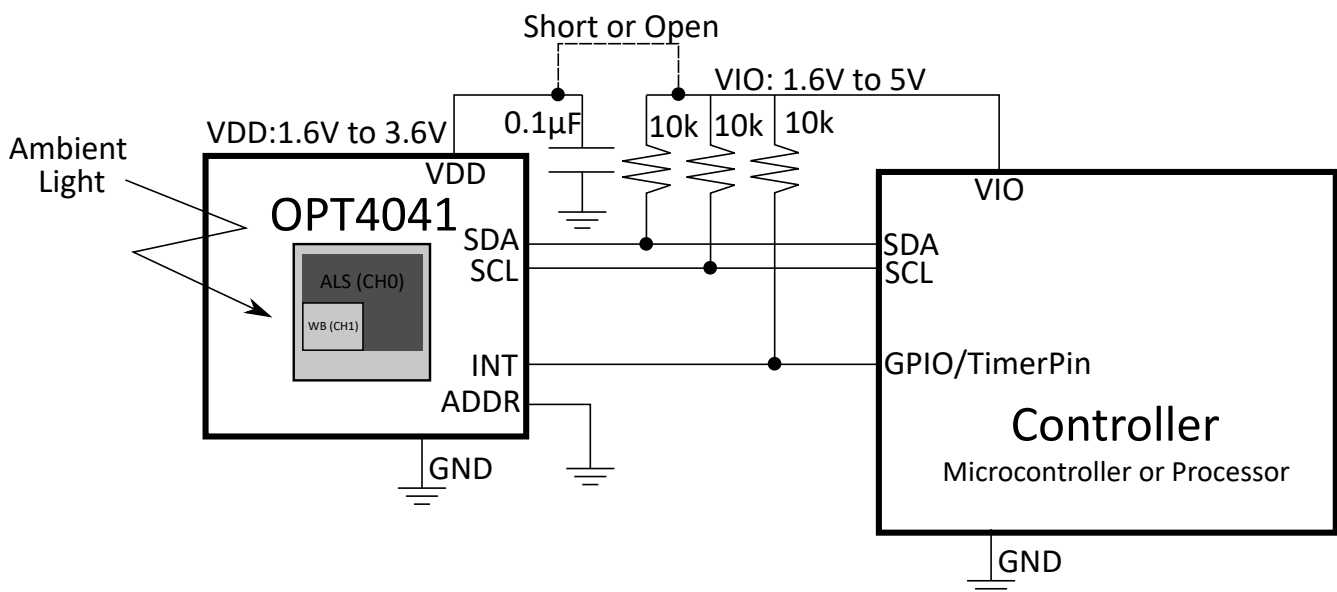

**Figure 8-1. Typical Application Schematic**

The power-supply and grounding considerations are discussed in the [Section 8.4](#) section.

Although spike suppression is integrated in the SDA and SCL pin circuits, use proper layout practices to minimize the amount of coupling into the communication lines. One possible introduction of noise occurs from

capacitively coupling signal edges between the two communication lines. Another possible noise introduction comes from other switching noise sources present in the system, especially for long communication lines. In noisy environments, shield communication lines to reduce the possibility of unintended noise coupling into the digital I/O lines that can be incorrectly interpreted.

### 8.2.1.1 Design Requirements

This section describes the design requirements for a light sensor integrated into a system behind an enclosure cutout with a dark glass. This application is a common example of a light sensor system integration. Key considerations, such as sensor field of view (FoV) and dark glass transmission, are discussed in [セクション 8.2.1.1.1](#).

#### 8.2.1.1.1 Optical Interface

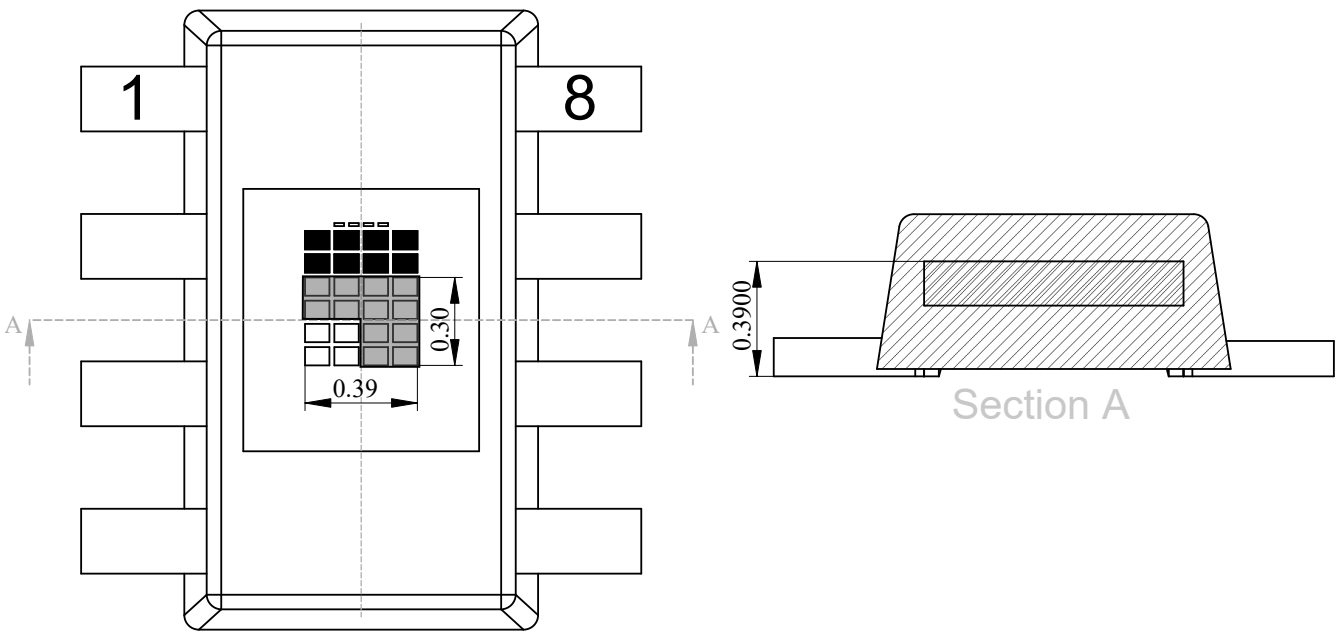
 8-2 shows the dimensions of the optical area. The gray area indicates the channel 0 photodiode and the white area indicates the channel 1 photodiode.

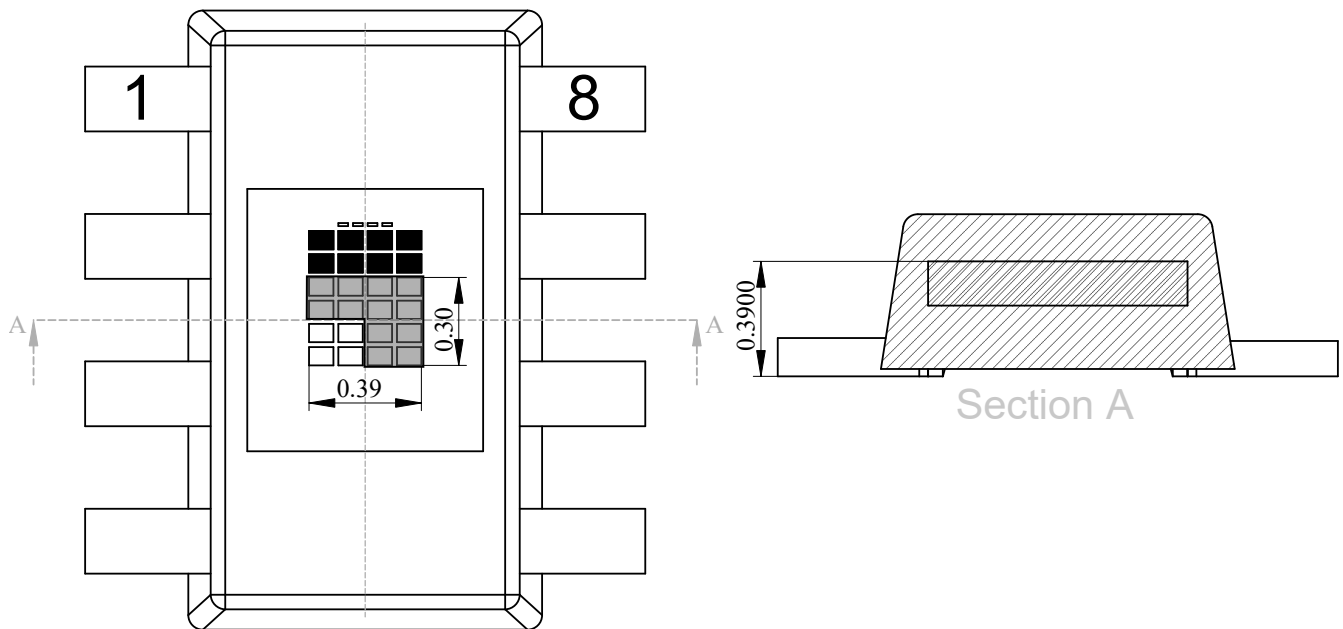

**図 8-2. Sensor Position**

Generally, any physical component that affects the light illuminating the sensing area of a light sensor also affects the performance of that light sensor. For example, a dark or opaque window can be used to further enhance the visual appeal of the design by hiding the sensor from view. This window material is typically transparent plastic or glass. Therefore, for the best performance, make sure to understand and control the effect of these components. Design a window width and height to permit light from a sufficient field of view to illuminate the sensor. For best performance, use a field of view of at least  $\pm 35^\circ$ , or preferably  $\pm 45^\circ$  or more. Understanding and designing the field of view is discussed further in the [OPT3001: Ambient Light Sensor Application Guide application note](#).

The visible-spectrum transmission for dark windows typically ranges between 5% to 30%, but can be less than 1%. Specify a visible-spectrum transmission as low as, but no more than, necessary to achieve sufficient visual appeal because decreased transmission decreases the available light for the sensor to measure. The windows are made dark by either applying an ink to a transparent window material, or including a dye or other optical substance within the window material. This attenuating transmission in the visible spectrum of the window creates a ratio between the light on the outside of the design and the light that is measured by the device. To accurately measure the light outside of the design, compensate the device measurement for this ratio.

Although the inks and dyes of dark windows serve a primary purpose of being minimally transmissive to visible light, some inks and dyes can also be very transmissive to infrared light. The use of these inks and dyes further decreases the ratio of visible to infrared light, and thus decreases sensor measurement accuracy. However, because of the excellent red and infrared rejection of the device, this effect is minimized, and good results are achieved under a dark window with similar spectral responses.

For best accuracy, avoid grill-like window structures, unless the designer understands the optical effects sufficiently. These grill-like window structures create a nonuniform illumination pattern on the sensor that causes light measurement results to vary with placement tolerances and the angle of incidence of the light. If a grill-like structure is desired, then this device is an excellent sensor choice because the device is minimally sensitive to illumination uniformity issues disrupting the measurement process.

Light pipes can appear attractive for aiding in the optomechanical design that brings light to the sensor; however, do not use light pipes with any light sensor unless the system designer fully understands the ramifications of the optical physics of light pipes within the full context of the design and objectives.

### 8.2.1.2 Detailed Design Procedure

#### 8.2.1.2.1 Optomechanical Design

After completing the electrical design, the next task is the optomechanical design. Window sizing and placement is discussed in more rigorous detail in the [OPT3001: Ambient Light Sensor Application Guide application note](#).

## 8.3 Best Design Practices

As with any optical product, take special care when handling the OPT4041. The optical surface of the device must be kept clean for the best performance, both when prototyping with the device and during mass production manufacturing procedures. Keep the optical surface clean of fingerprints, dust, and other optical-inhibiting contaminants. Use a properly-sized vacuum manipulation tool to handle the device.

If the optical surface of the device requires cleaning, then use a few gentle brushes with a soft swab of deionized water or isopropyl alcohol. Avoid potentially abrasive cleaning and manipulating tools and excessive force that can scratch the optical surface.

If the OPT4041 performance is diminished in any way, then inspect the optical surface for dirt, scratches, or other optical artifacts.

## 8.4 Power Supply Recommendations

Although the OPT4041 has low sensitivity to power-supply issues, good practices are always recommended. For best performance, the device VDD pin must have a stable, low-noise power supply with a 100nF bypass capacitor close to the device and solid grounding. There are many options for powering the device because of the device low current consumption levels.

## 8.5 Layout

### 8.5.1 Layout Guidelines

The PCB layout design for the OPT4041 requires a couple of considerations. Bypass the power supply with a capacitor placed close to the device. Note that optically reflective surfaces of components also affect the performance of the design. The three-dimensional geometry of all components and structures around the sensor must be taken into consideration to prevent unexpected results from secondary optical reflections. Placing capacitors and components at a distance of at least twice the height of the component is typically sufficient. The best optical layout is to place all close components on the opposite side of the PCB from the device. However, this approach is not practical for the constraints of every design. An example PCB layout with the OPT4041 is shown in [Figure 8-3](#).

### 8.5.2 Layout Example

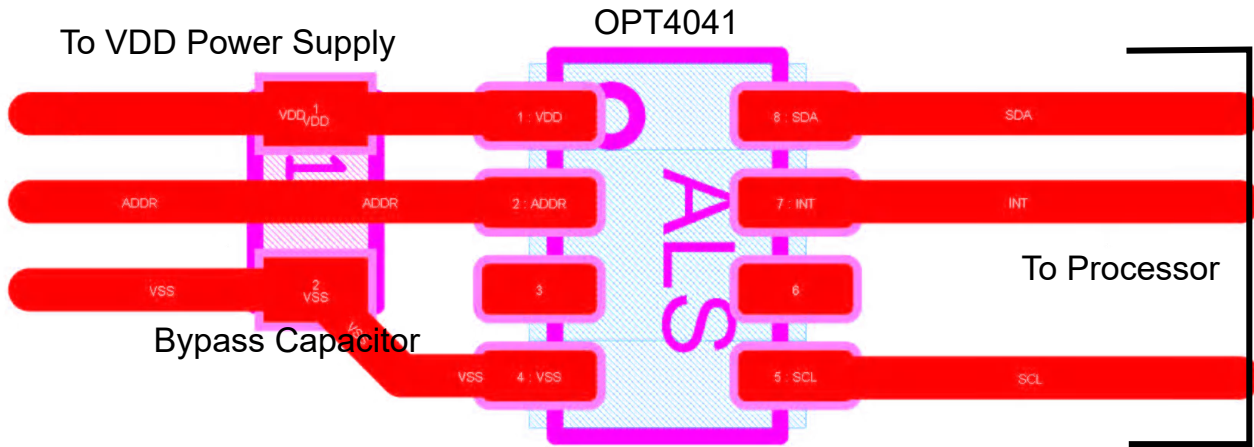

8-3. Layout Example for SOT-5X3 package

### 8.5.2.1 Soldering and Handling Recommendations

The OPT4041 has been qualified for three soldering reflow operations per JEDEC JSTD-020.

Note that excessive heat can discolor the device and affect optical performance.

See application report [SLUA271, QFN/SON PCB Attachment](#), for details on soldering thermal profile and other information. If the OPT4041 must be removed from a PCB, discard the device and do not reattach.

As with most optical devices, handle the device with special care to make sure that optical surfaces stay clean and free from damage. See [セクション 8.3](#) for more detailed recommendations. For best optical performance, solder flux and any other possible debris must be cleaned after soldering processes.



注

The bottom side of the device features an angled feature to denote the PIN 1

図 8-4. Identification Feature for PIN 1



図 8-5. Identification Features for PIN 1 on Package

## 9 Device and Documentation Support

### 9.1 Documentation Support

#### 9.1.1 Related Documentation

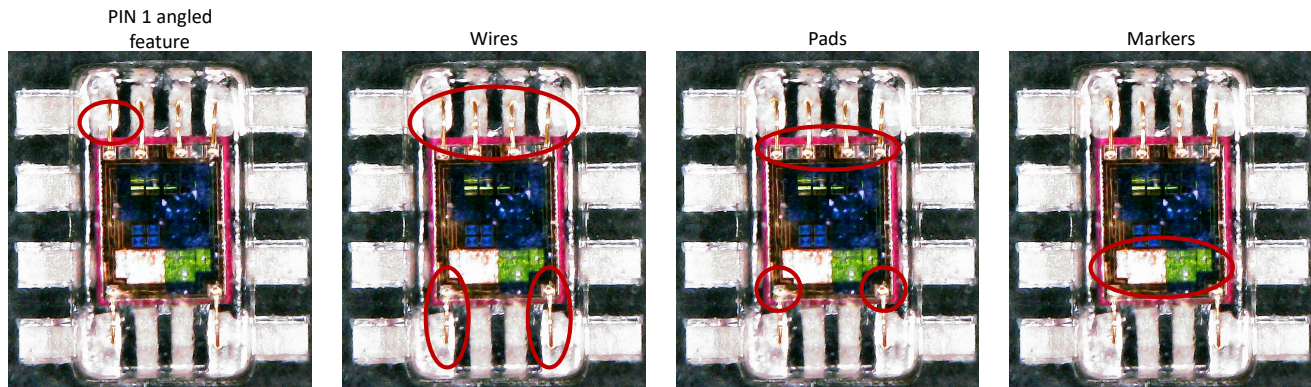
For related documentation see the following:

- Texas Instruments, [OPT3001: Ambient Light Sensor Application Guide](#), application note
- Texas Instruments, [OPT4041EVM User's Guide](#)

### 9.2 ドキュメントの更新通知を受け取る方法

ドキュメントの更新についての通知を受け取るには、[www.tij.co.jp](http://www.tij.co.jp) のデバイス製品フォルダを開いてください。[通知] をクリックして登録すると、変更されたすべての製品情報に関するダイジェストを毎週受け取ることができます。変更の詳細については、改訂されたドキュメントに含まれている改訂履歴をご覧ください。

### 9.3 サポート・リソース

テキサス・インスツルメンツ E2E™ サポート・フォーラムは、エンジニアが検証済みの回答と設計に関するヒントをエキスパートから迅速かつ直接得ることができる場所です。既存の回答を検索したり、独自の質問をしたりすることで、設計に必要な支援を迅速に得ることができます。

リンクされているコンテンツは、各寄稿者により「現状のまま」提供されるものです。これらはテキサス・インスツルメンツの仕様を構成するものではなく、必ずしもテキサス・インスツルメンツの見解を反映したものではありません。テキサス・インスツルメンツの[使用条件](#)を参照してください。

### 9.4 Trademarks

テキサス・インスツルメンツ E2E™ is a trademark of Texas Instruments.

すべての商標は、それぞれの所有者に帰属します。

### 9.5 静電気放電に関する注意事項



この IC は、ESD によって破損する可能性があります。テキサス・インスツルメンツは、IC を取り扱う際には常に適切な注意を払うことを推奨します。正しい取り扱いおよび設置手順に従わない場合、デバイスを破損するおそれがあります。

ESD による破損は、わずかな性能低下からデバイスの完全な故障まで多岐にわたります。精密な IC の場合、パラメータがわずかに変化するだけで公表されている仕様から外れる可能性があるため、破損が発生しやすくなっています。

### 9.6 用語集

[テキサス・インスツルメンツ用語集](#) この用語集には、用語や略語の一覧および定義が記載されています。

## 10 Revision History

資料番号末尾の英字は改訂を表しています。その改訂履歴は英語版に準じています。

| DATE          | REVISION | NOTES           |
|---------------|----------|-----------------|
| December 2024 | *        | Initial Release |

## 11 Mechanical, Packaging, and Orderable Information

The following pages include mechanical, packaging, and orderable information. This information is the most current data available for the designated devices. This data is subject to change without notice and revision of this document. For browser-based versions of this data sheet, refer to the left-hand navigation.

## 11.1 Mechanical Data

**PACKAGE OUTLINE**  
**FCSOT - 0.6 mm max height**
**DTS0008A**

FLIPCHIP SOT

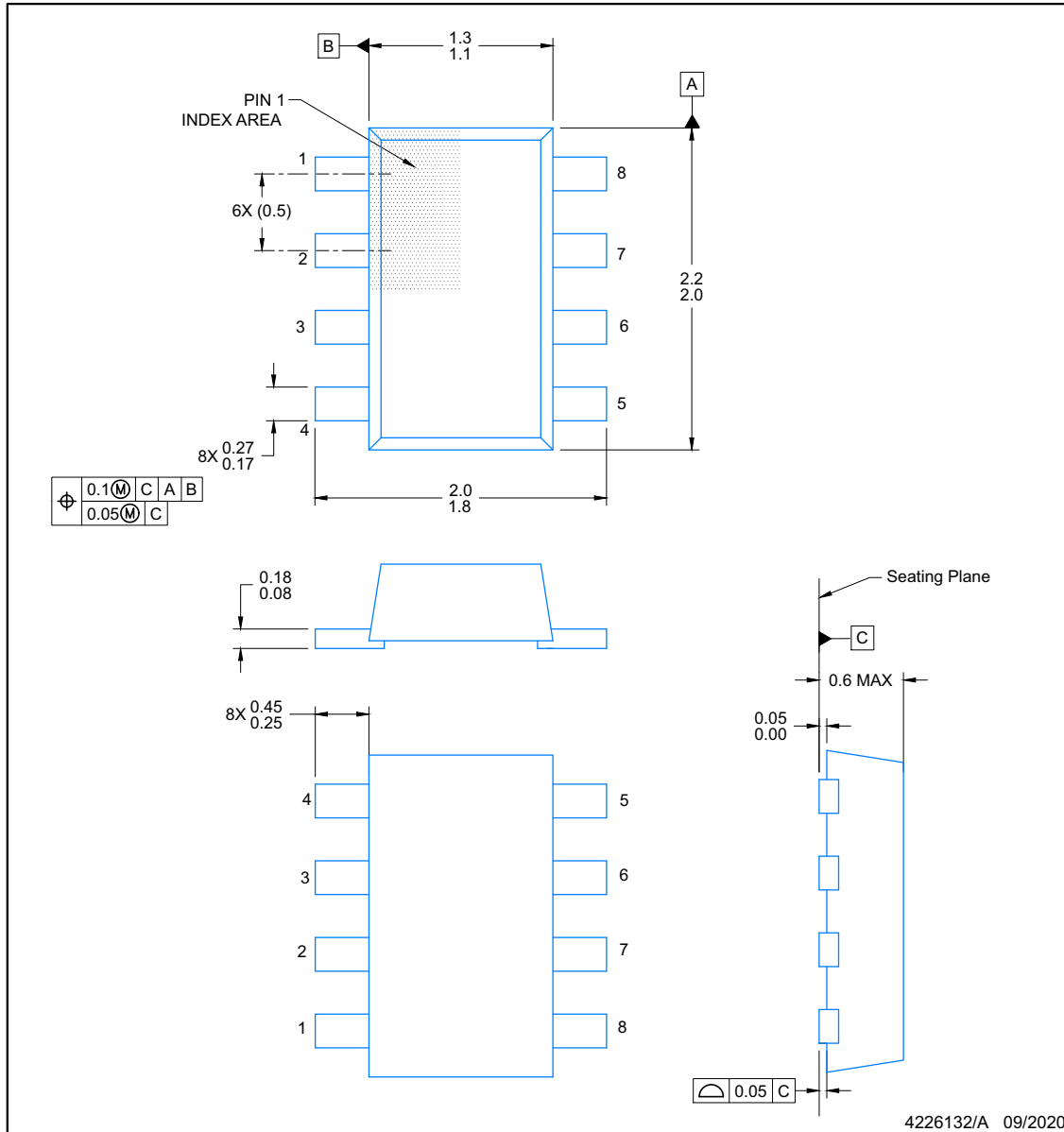

## NOTES:

1. All linear dimensions are in millimeters. Any dimensions in parenthesis are for reference only. Dimensioning and tolerancing per ASME Y14.5M.
2. This drawing is subject to change without notice.
3. Body dimensions do not include mold flash, protrusions or gate burrs. Mold flash, interlead flash, protrusions or gate burrs shall not exceed 0.15 per end or side.
4. Reference JEDEC registration TO-236, except minimum foot length.

EXAMPLE BOARD LAYOUT  
FCSOT - 0.6 mm max height

DTS0008A

FLIPCHIP SOT

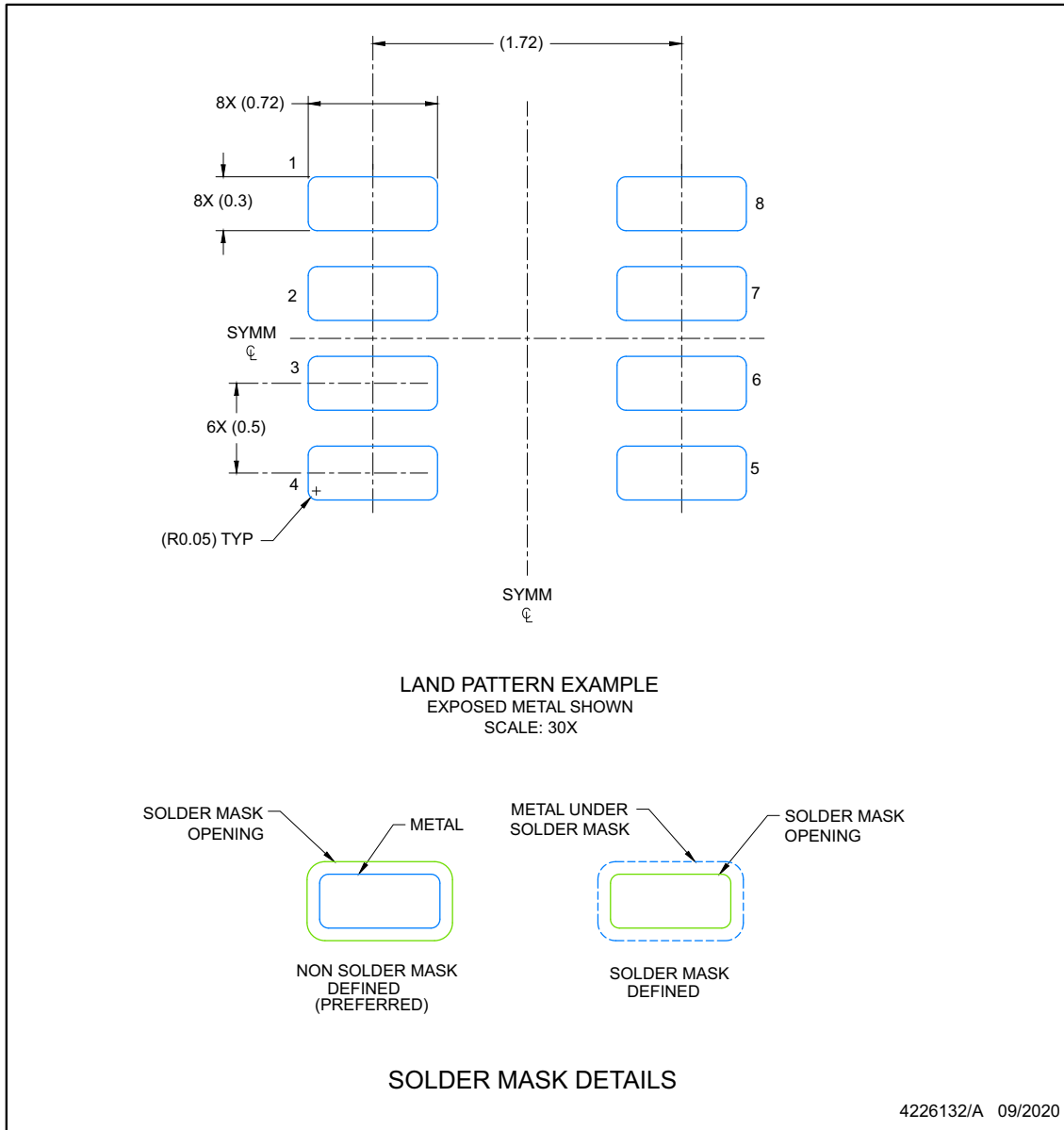

NOTES: (continued)

5. Publication IPC-7351 may have alternate designs.
6. Solder mask tolerances between and around signal pads can vary based on board fabrication site.

## EXAMPLE STENCIL DESIGN

**DTS0008A**

**FCSOT - 0.6 mm max height**

FLIPCHIP SOT

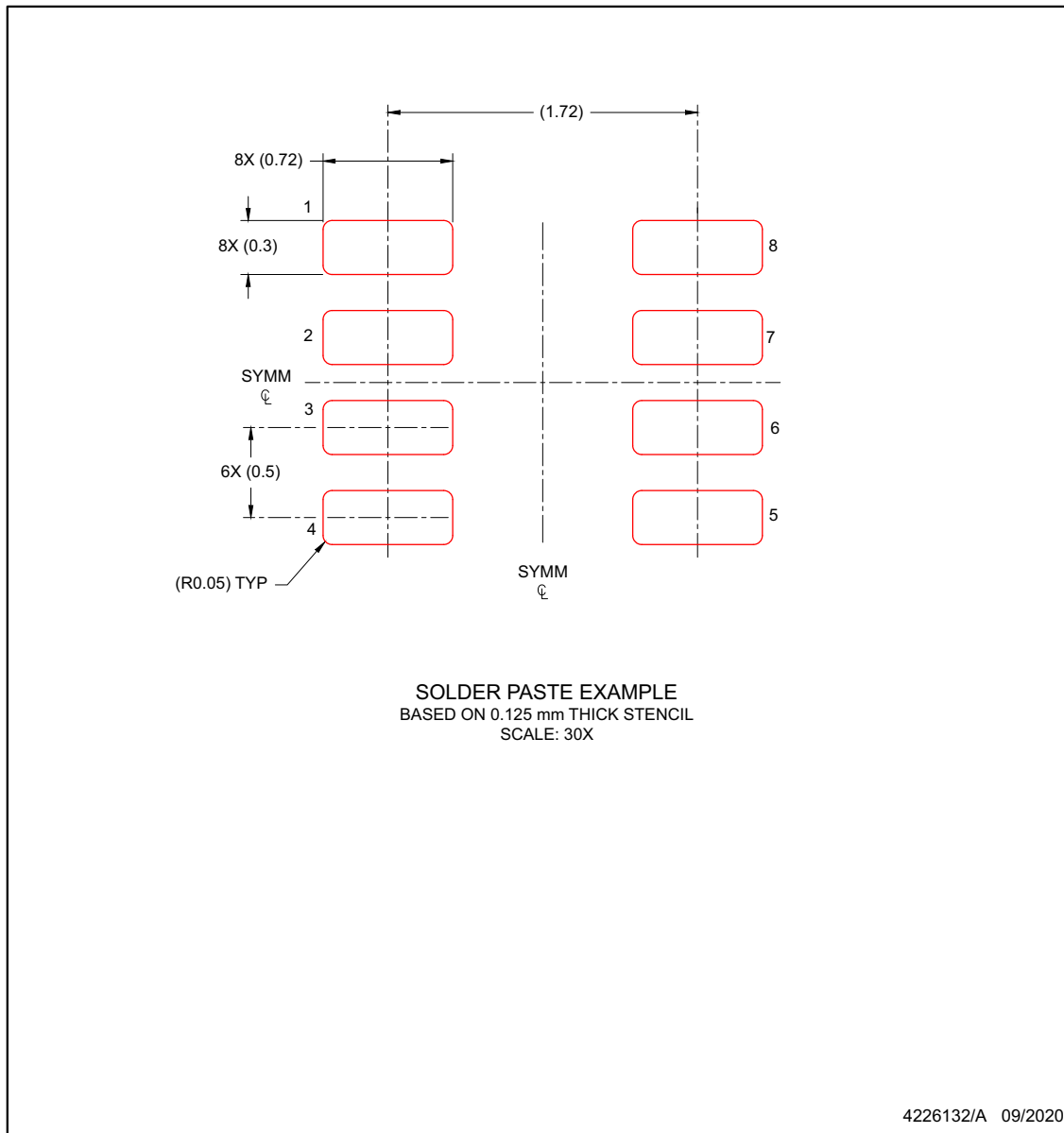

NOTES: (continued)

7. Laser cutting apertures with trapezoidal walls and rounded corners may offer better paste release. IPC-7525 may have alternate design recommendations.
8. Board assembly site may have different recommendations for stencil design.

## 11.2 Package Option Addendum

### Packaging Information

| Orderable Device | Status | Package Type | Package Drawing | Pins | Package Qty | Eco Plan     | Lead/Ball Finish | MSL Peak Temp       | Op Temp (°C) | Device Marking |
|------------------|--------|--------------|-----------------|------|-------------|--------------|------------------|---------------------|--------------|----------------|
| OPT4041DTS       | ACTIVE | SOT-5X3      | DTS             | 8    | 3000        | RoHS & Green | NIPDAU           | Level-2-260C-1 YEAR | -40 TO 85    | 3004           |

**Important Information and Disclaimer:** The information provided on this page represents TI's knowledge and belief as of the date that it is provided. TI bases its knowledge and belief on information provided by third parties, and makes no representation or warranty as to the accuracy of such information. Efforts are underway to better integrate information from third parties. TI has taken and continues to take reasonable steps to provide representative and accurate information but may not have conducted destructive testing or chemical analysis on incoming materials and chemicals. TI and TI suppliers consider certain information to be proprietary, and thus CAS numbers and other limited information may not be available for release.

In no event shall TI's liability arising out of such information exceed the total purchase price of the TI part(s) at issue in this document sold by TI to Customer on an annual basis.

### Packaging Information

| Orderable Device | Status | Package Type | Package Drawing | Pins | Package Qty | Eco Plan | Lead/Ball Finish | MSL Peak Temp | Op Temp (°C) | Device Marking |
|------------------|--------|--------------|-----------------|------|-------------|----------|------------------|---------------|--------------|----------------|
|                  |        |              |                 |      |             |          |                  |               |              |                |
|                  |        |              |                 |      |             |          |                  |               |              |                |
|                  |        |              |                 |      |             |          |                  |               |              |                |

**Important Information and Disclaimer:** The information provided on this page represents TI's knowledge and belief as of the date that it is provided. TI bases its knowledge and belief on information provided by third parties, and makes no representation or warranty as to the accuracy of such information. Efforts are underway to better integrate information from third parties. TI has taken and continues to take reasonable steps to provide representative and accurate information but may not have conducted destructive testing or chemical analysis on incoming materials and chemicals. TI and TI suppliers consider certain information to be proprietary, and thus CAS numbers and other limited information may not be available for release.

In no event shall TI's liability arising out of such information exceed the total purchase price of the TI part(s) at issue in this document sold by TI to Customer on an annual basis.

### 11.3 Tape and Reel Information

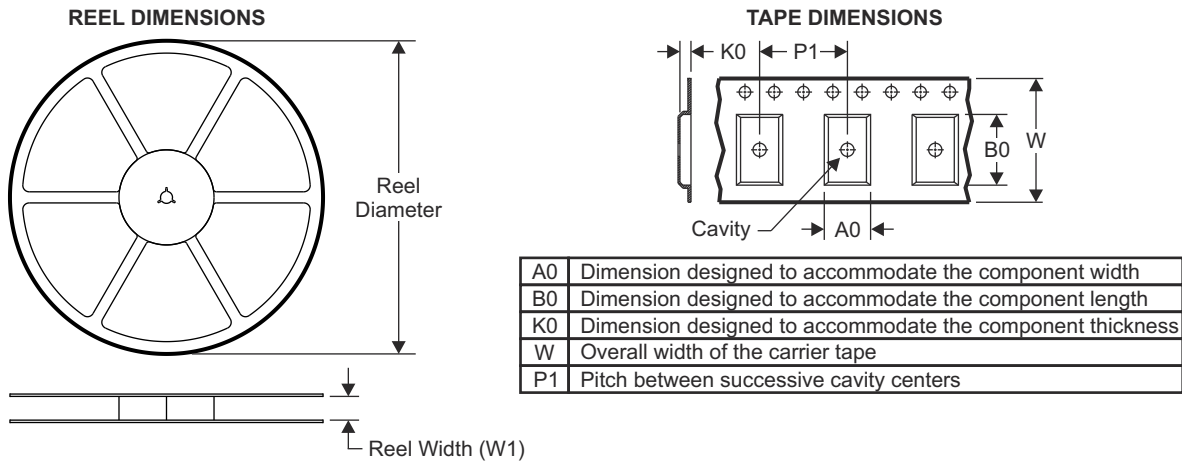

#### QUADRANT ASSIGNMENTS FOR PIN 1 ORIENTATION IN TAPE

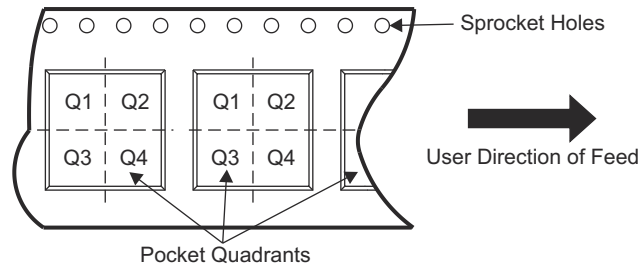

| Device     | Package Type | Package Drawing | Pins | SPQ | Reel Diameter (mm) | Reel Width W1 (mm) | A0 (mm) | B0 (mm) | K0 (mm) | P1 (mm) | W (mm) | Pin1 Quadrant |
|------------|--------------|-----------------|------|-----|--------------------|--------------------|---------|---------|---------|---------|--------|---------------|
| OPT4041DTS | SOT-5X3      | DTS             | 8    |     |                    |                    |         |         |         |         |        |               |

**TAPE AND REEL BOX DIMENSIONS**

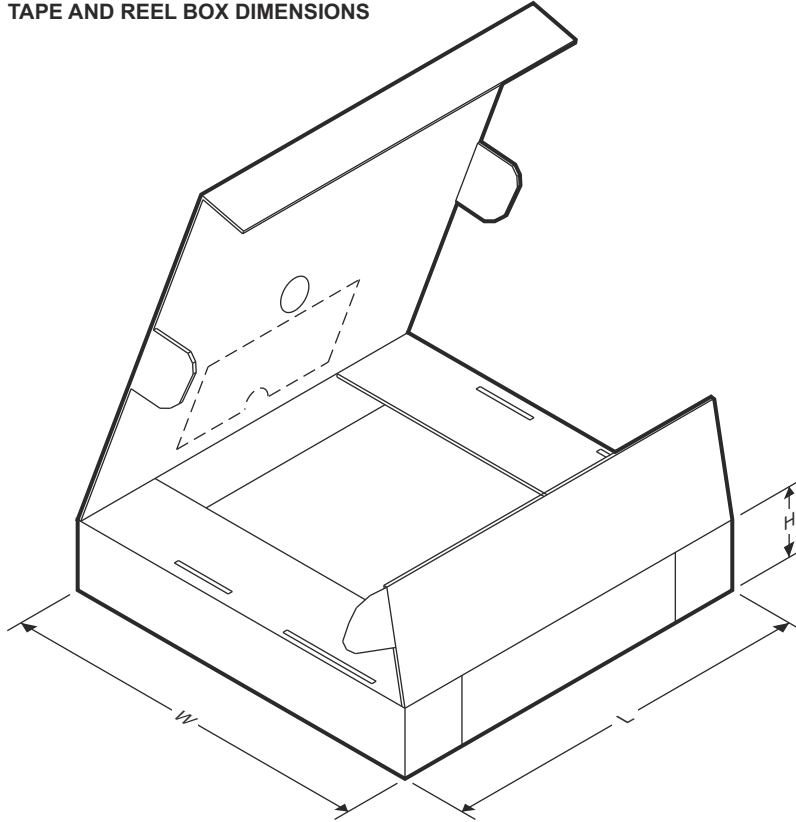

| Device | Package Type | Package Drawing | Pins | SPQ | Length (mm) | Width (mm) | Height (mm) |
|--------|--------------|-----------------|------|-----|-------------|------------|-------------|
|        |              |                 |      |     |             |            |             |

## 重要なお知らせと免責事項

テキサス・インスツルメンツは、技術データと信頼性データ (データシートを含みます)、設計リソース (リファレンス デザインを含みます)、アプリケーションや設計に関する各種アドバイス、Web ツール、安全性情報、その他のリソースを、欠陥が存在する可能性のある「現状のまま」提供しており、商品性および特定目的に対する適合性の黙示保証、第三者の知的財産権の非侵害保証を含むいかなる保証も、明示的または黙示的にかかわらず拒否します。

これらのリソースは、テキサス・インスツルメンツ製品を使用する設計の経験を積んだ開発者への提供を意図したものです。(1) お客様のアプリケーションに適した テキサス・インスツルメンツ製品の選定、(2) お客様のアプリケーションの設計、検証、試験、(3) お客様のアプリケーションに該当する各種規格や、その他のあらゆる安全性、セキュリティ、規制、または他の要件への確実な適合に関する責任を、お客様のみが単独で負うものとします。

上記の各種リソースは、予告なく変更される可能性があります。これらのリソースは、リソースで説明されている テキサス・インスツルメンツ製品を使用するアプリケーションの開発の目的でのみ、テキサス・インスツルメンツはその使用をお客様に許諾します。これらのリソースに関して、他の目的で複製することや掲載することは禁止されています。テキサス・インスツルメンツや第三者の知的財産権のライセンスが付与されている訳ではありません。お客様は、これらのリソースを自身で使用した結果発生するあらゆる申し立て、損害、費用、損失、責任について、テキサス・インスツルメンツおよびその代理人を完全に補償するものとし、テキサス・インスツルメンツは一切の責任を拒否します。

テキサス・インスツルメンツの製品は、[テキサス・インスツルメンツの販売条件](#)、または [ti.com](https://www.ti.com) やかかる テキサス・インスツルメンツ製品の関連資料などのいずれかを通じて提供する適用可能な条項の下で提供されています。テキサス・インスツルメンツがこれらのリソースを提供することは、適用されるテキサス・インスツルメンツの保証または他の保証の放棄の拡大や変更を意味するものではありません。

お客様がいかなる追加条項または代替条項を提案した場合でも、テキサス・インスツルメンツはそれらに異議を唱え、拒否します。

郵送先住所: Texas Instruments, Post Office Box 655303, Dallas, Texas 75265

Copyright © 2024, Texas Instruments Incorporated

**PACKAGING INFORMATION**

| Orderable part number       | Status<br>(1) | Material type<br>(2) | Package   Pins    | Package qty   Carrier | RoHS<br>(3) | Lead finish/<br>Ball material<br>(4) | MSL rating/<br>Peak reflow<br>(5) | Op temp (°C)    | Part marking<br>(6) |
|-----------------------------|---------------|----------------------|-------------------|-----------------------|-------------|--------------------------------------|-----------------------------------|-----------------|---------------------|
| <a href="#">OPT4041DTSR</a> | Active        | Production           | SOT-5X3 (DTS)   8 | 250   SMALL T&R       | Yes         | NIPDAU                               | Level-2-260C-1 YEAR               | -40 to 85       | 4041                |
| OPT4041DTSR.A               | Active        | Production           | SOT-5X3 (DTS)   8 | 250   SMALL T&R       | Yes         | NIPDAU                               | Level-2-260C-1 YEAR               | See OPT4041DTSR | 4041                |

(1) **Status:** For more details on status, see our [product life cycle](#).

(2) **Material type:** When designated, preproduction parts are prototypes/experimental devices, and are not yet approved or released for full production. Testing and final process, including without limitation quality assurance, reliability performance testing, and/or process qualification, may not yet be complete, and this item is subject to further changes or possible discontinuation. If available for ordering, purchases will be subject to an additional waiver at checkout, and are intended for early internal evaluation purposes only. These items are sold without warranties of any kind.

(3) **RoHS values:** Yes, No, RoHS Exempt. See the [TI RoHS Statement](#) for additional information and value definition.

(4) **Lead finish/Ball material:** Parts may have multiple material finish options. Finish options are separated by a vertical ruled line. Lead finish/Ball material values may wrap to two lines if the finish value exceeds the maximum column width.

(5) **MSL rating/Peak reflow:** The moisture sensitivity level ratings and peak solder (reflow) temperatures. In the event that a part has multiple moisture sensitivity ratings, only the lowest level per JEDEC standards is shown. Refer to the shipping label for the actual reflow temperature that will be used to mount the part to the printed circuit board.

(6) **Part marking:** There may be an additional marking, which relates to the logo, the lot trace code information, or the environmental category of the part.

Multiple part markings will be inside parentheses. Only one part marking contained in parentheses and separated by a "~" will appear on a part. If a line is indented then it is a continuation of the previous line and the two combined represent the entire part marking for that device.

**Important Information and Disclaimer:**The information provided on this page represents TI's knowledge and belief as of the date that it is provided. TI bases its knowledge and belief on information provided by third parties, and makes no representation or warranty as to the accuracy of such information. Efforts are underway to better integrate information from third parties. TI has taken and continues to take reasonable steps to provide representative and accurate information but may not have conducted destructive testing or chemical analysis on incoming materials and chemicals. TI and TI suppliers consider certain information to be proprietary, and thus CAS numbers and other limited information may not be available for release.

In no event shall TI's liability arising out of such information exceed the total purchase price of the TI part(s) at issue in this document sold by TI to Customer on an annual basis.

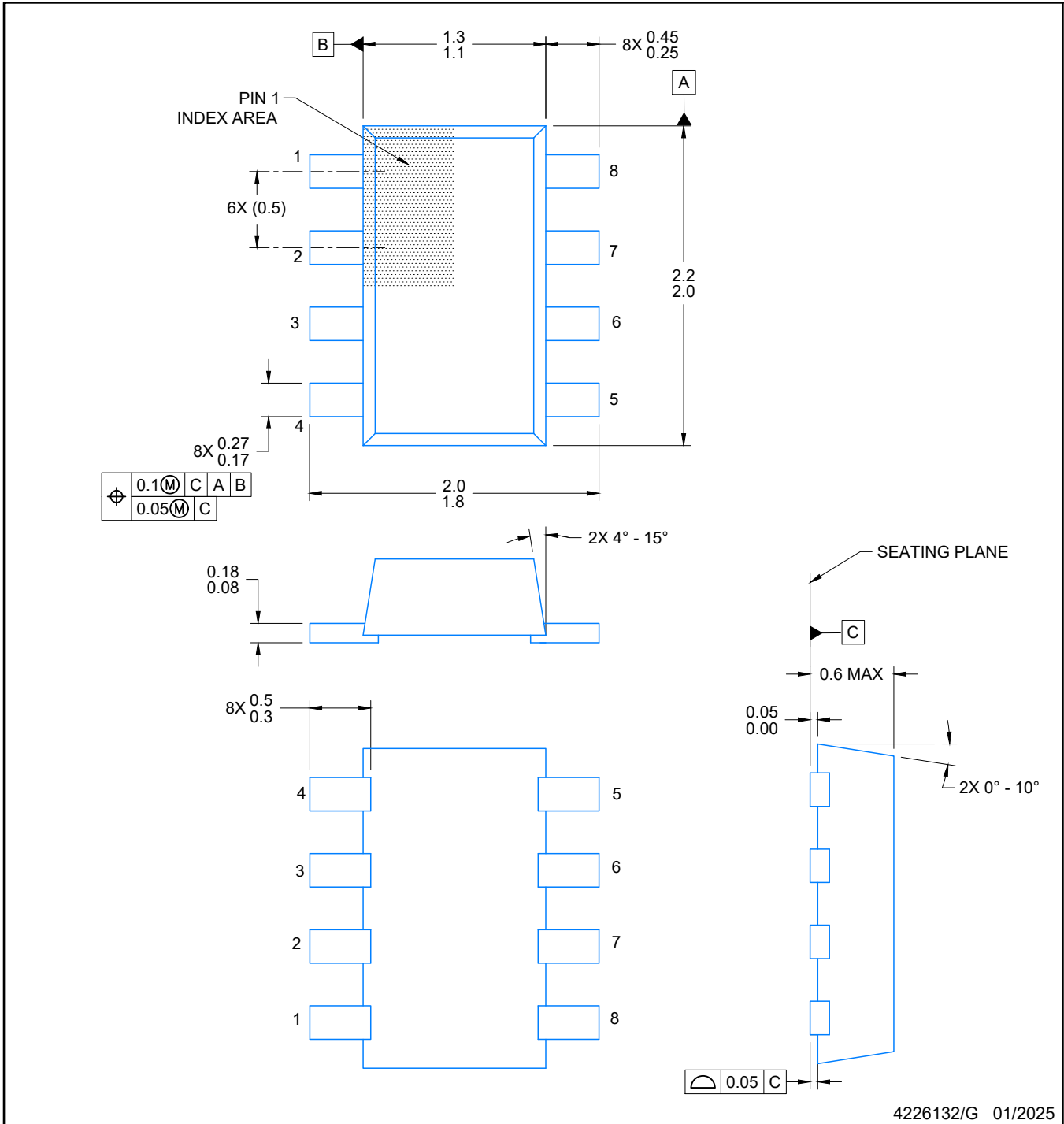

4226132/G 01/2025

**NOTES:**

1. All linear dimensions are in millimeters. Any dimensions in parenthesis are for reference only. Dimensioning and tolerancing per ASME Y14.5M.
2. This drawing is subject to change without notice.
3. Body dimensions do not include mold flash, protrusions or gate burrs. Mold flash, interlead flash, protrusions or gate burrs shall not exceed 0.171 per end or side.
4. The side flash along with the stub lead is allowed.
5. Any detached side flash from the stub lead is allowed unless it is touching the bottom side of the lead.

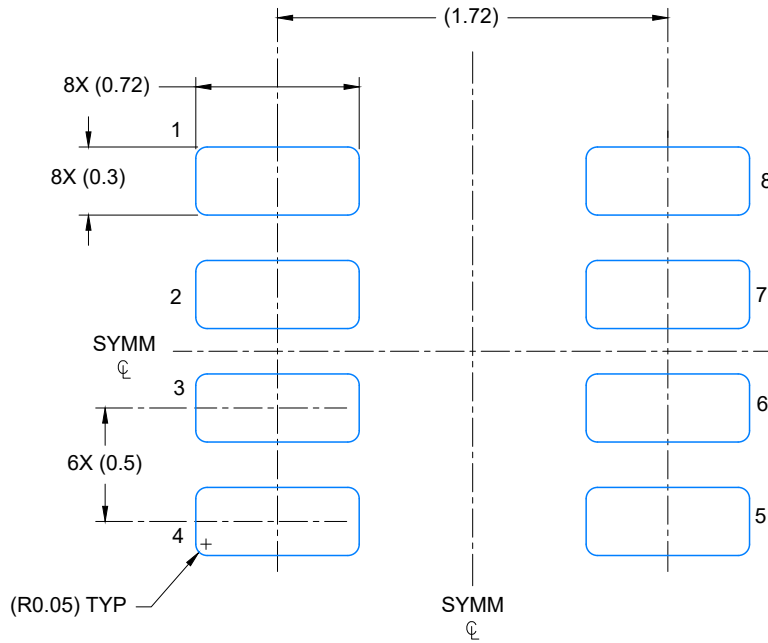

LAND PATTERN EXAMPLE  
EXPOSED METAL SHOWN  
SCALE: 30X

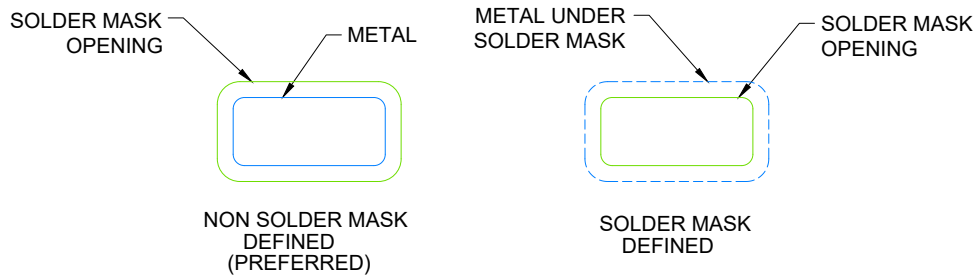

SOLDER MASK DETAILS

4226132/G 01/2025

NOTES: (continued)

- 6. Publication IPC-7351 may have alternate designs.
- 7. Solder mask tolerances between and around signal pads can vary based on board fabrication site.
- 8. Land pad design aligns to IPC-610, Bottom Termination Component (BTC) solder joint inspection criteria.

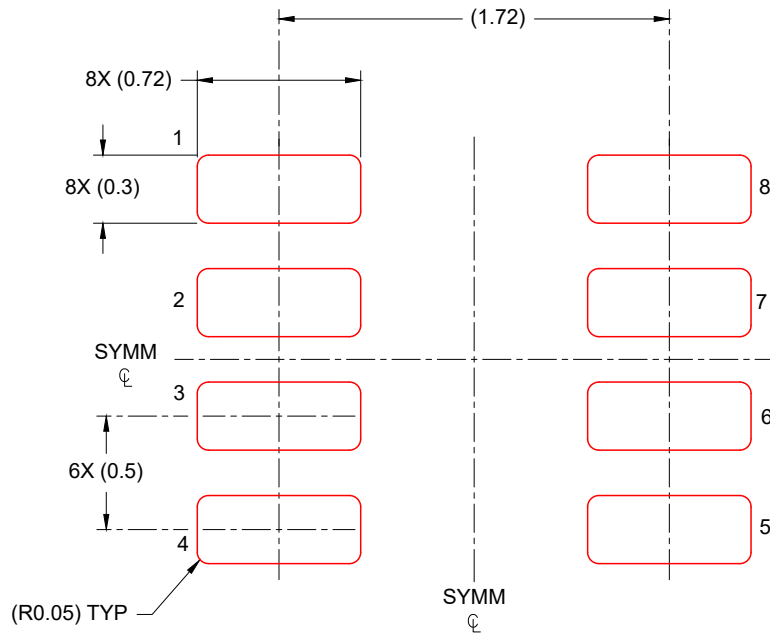

SOLDER PASTE EXAMPLE  
BASED ON 0.125 mm THICK STENCIL  
SCALE: 30X

4226132/G 01/2025

NOTES: (continued)

- 9. Laser cutting apertures with trapezoidal walls and rounded corners may offer better paste release. IPC-7525 may have alternate design recommendations.
- 10. Board assembly site may have different recommendations for stencil design.

## 重要なお知らせと免責事項

TI は、技術データと信頼性データ (データシートを含みます)、設計リソース (リファレンス デザインを含みます)、アプリケーションや設計に関する各種アドバイス、Web ツール、安全性情報、その他のリソースを、欠陥が存在する可能性のある「現状のまま」提供しており、商品性および特定目的に対する適合性の黙示保証、第三者の知的財産権の非侵害保証を含むいかなる保証も、明示的または黙示的にかかわらず拒否します。

これらのリソースは、TI 製品を使用する設計の経験を積んだ開発者への提供を意図したものです。(1) お客様のアプリケーションに適した TI 製品の選定、(2) お客様のアプリケーションの設計、検証、試験、(3) お客様のアプリケーションに該当する各種規格や、その他のあらゆる安全性、セキュリティ、規制、または他の要件への確実な適合に関する責任を、お客様のみが単独で負うものとし、

上記の各種リソースは、予告なく変更される可能性があります。これらのリソースは、リソースで説明されている TI 製品を使用するアプリケーションの開発の目的でのみ、TI はその使用をお客様に許諾します。これらのリソースに関して、他の目的で複製することや掲載することは禁止されています。TI や第三者の知的財産権のライセンスが付与されている訳ではありません。お客様は、これらのリソースを自身で使用した結果発生するあらゆる申し立て、損害、費用、損失、責任について、TI およびその代理人を完全に補償するものとし、TI は一切の責任を拒否します。

TI の製品は、[TI の販売条件](#)、[TI の総合的な品質ガイドライン](#)、[ti.com](#) または TI 製品などに関連して提供される他の適用条件に従い提供されます。TI がこれらのリソースを提供することは、適用される TI の保証または他の保証の放棄の拡大や変更を意味するものではありません。TI がカスタム、またはカスタマー仕様として明示的に指定していない限り、TI の製品は標準的なカタログに掲載される汎用機器です。

お客様がいかなる追加条項または代替条項を提案する場合も、TI はそれらに異議を唱え、拒否します。

Copyright © 2026, Texas Instruments Incorporated

最終更新日 : 2025 年 10 月