

SN54ALS996, SN74ALS996 8-BIT D-TYPE EDGE-TRIGGERED READ-BACK LATCHES

SDAS098B – OCTOBER 1984 – REVISED JANUARY 1995

- 3-State I/O-Type Read-Back Inputs
- Bus-Structured Pinout
- T/\overline{C} Determines True or Complementary Data at Q Outputs
- Package Options Include Plastic Small-Outline (DW) Packages, Ceramic Chip Carriers (FK), and Standard Plastic (NT) and Ceramic (JT) 300-mil DIPs

description

These 8-bit latches are designed specifically for storing the contents of the input data bus and providing the capability of reading back the stored data onto the input data bus. The Q outputs are designed with bus-driving capability.

The edge-triggered flip-flops enter the data on the low-to-high transition of the clock (CLK) input when the enable (\overline{EN}) input is low. Data can be read back onto the data inputs by taking the read (\overline{RD}) input low, in addition to having \overline{EN} low. When \overline{EN} is high, both the read-back and write modes are disabled. Transitions on \overline{EN} should only be made with CLK high to prevent false clocking.

The polarity of the Q outputs can be controlled by the polarity (T/\overline{C}) input. When T/\overline{C} is high, Q is the same as is stored in the flip-flops. When T/\overline{C} is low, the output data is inverted. The Q outputs can be placed in the high-impedance state by taking the output-enable (\overline{OE}) input high. \overline{OE} does not affect the internal operation of the register. Old data can be retained or new data can be entered while the outputs are off.

A low level at the clear (\overline{CLR}) input resets the internal registers low. The clear function is asynchronous and overrides all other register functions.

The -1 version of the SN74ALS996 is identical to the standard version, except that the recommended maximum I_{OL} for the -1 version is increased to 48 mA. There is no -1 version of the SN54ALS996.

The SN54ALS996 is characterized for operation over the full military temperature range of -55°C to 125°C . The SN74ALS996 is characterized for operation from 0°C to 70°C .

SN54ALS996 . . . JT PACKAGE
SN74ALS996 . . . DW OR NT PACKAGE
(TOP VIEW)

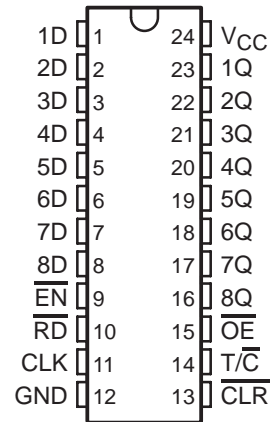

SN54ALS996 . . . FK PACKAGE
(TOP VIEW)

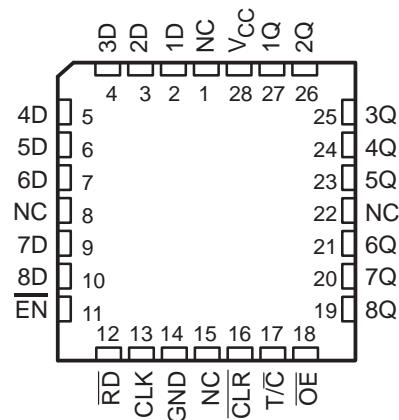

NC – No internal connection

SN54ALS996, SN74ALS996

8-BIT D-TYPE EDGE-TRIGGERED READ-BACK LATCHES

SDAS098B – OCTOBER 1984 – REVISED JANUARY 1995

logic symbol†

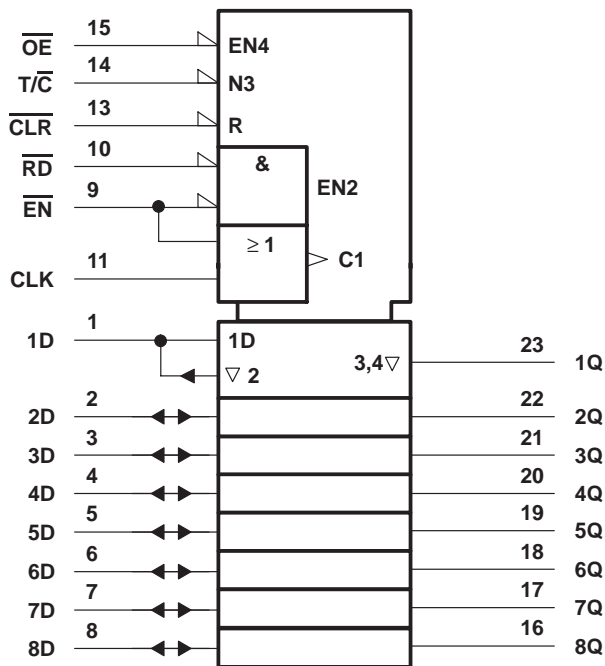

† This symbol is in accordance with ANSI/IEEE Std 91-1984 and IEC Publication 617-12. Pin numbers shown are for the DW, JT, and NT packages.

logic diagram (positive logic)

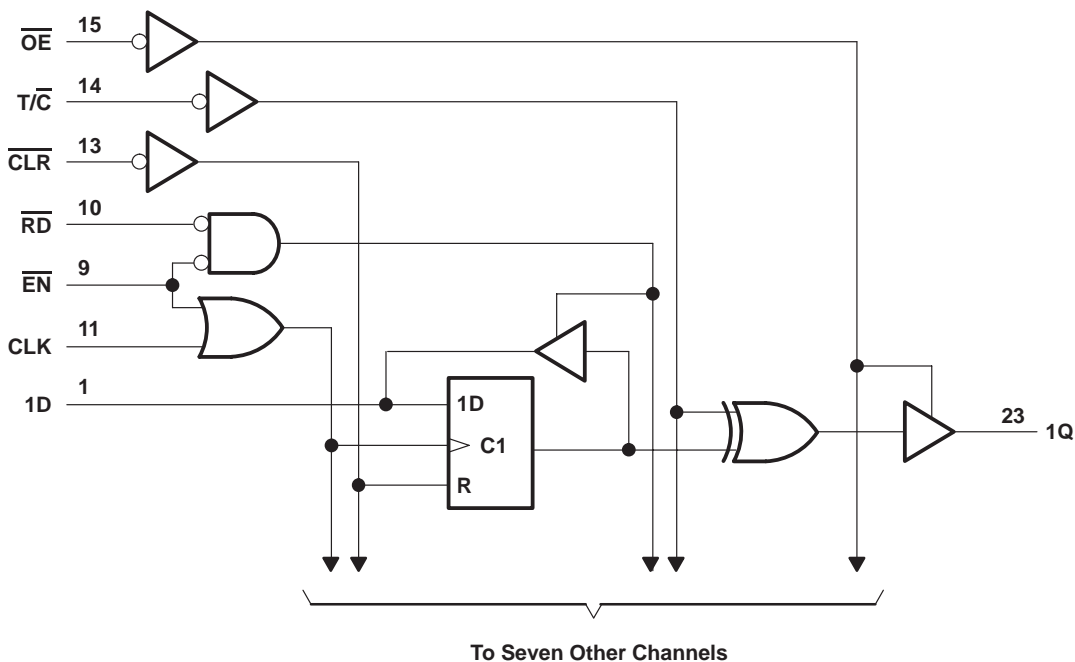

Pin numbers shown are for the DW, JT, and NT packages.

SN54ALS996, SN74ALS996 8-BIT D-TYPE EDGE-TRIGGERED READ-BACK LATCHES

SDAS098B – OCTOBER 1984 – REVISED JANUARY 1995

timing diagram

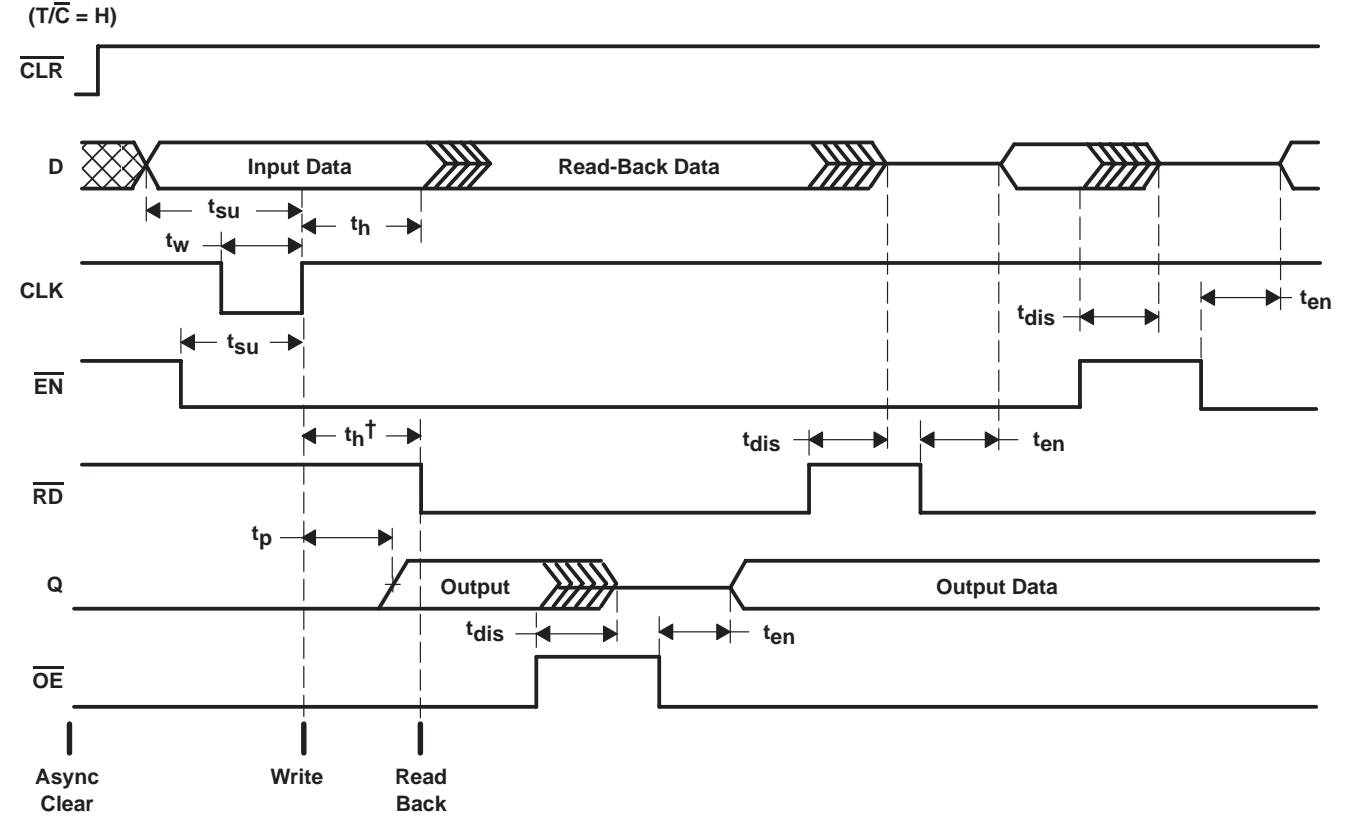

† This hold time ensures that the read-back circuit will not create a conflict on the input data bus.

absolute maximum ratings over operating free-air temperature range (unless otherwise noted)‡

Supply voltage, V_{CC}	7 V
Input voltage, V_I (\overline{OE} , \overline{RD} , \overline{EN} , CLK, \overline{CLR} , and T/\overline{C})	7 V
Voltage applied to D inputs and to disabled 3-state outputs	5.5 V
Operating free-air temperature range, T_A : SN54ALS996	-55°C to 125°C
SN74ALS996	0°C to 70°C
Storage temperature range	-65°C to 150°C

‡ Stresses beyond those listed under "absolute maximum ratings" may cause permanent damage to the device. These are stress ratings only, and functional operation of the device at these or any other conditions beyond those indicated under "recommended operating conditions" is not implied. Exposure to absolute-maximum-rated conditions for extended periods may affect device reliability.



SN54ALS996, SN74ALS996

8-BIT D-TYPE EDGE-TRIGGERED READ-BACK LATCHES

SDAS098B – OCTOBER 1984 – REVISED JANUARY 1995

recommended operating conditions

			SN54ALS996			SN74ALS996			UNIT	
			MIN	NOM	MAX	MIN	NOM	MAX		
V _{CC}	Supply voltage		4.5	5	5.5	4.5	5	5.5	V	
V _{IH}	High-level input voltage	All inputs				2			V	
		All inputs except \overline{OE} , \overline{RD}	2							
		\overline{OE} , \overline{RD}	2.2							
V _{IL}	Low-level input voltage		0.8			0.8			V	
I _{OH}	High-level output current	Q	-1			-2.6			mA	
		D	-0.4			-0.4				
I _{OL}	Low-level output current	Q	12			24			mA	
		D	8			8				
f _{clock}	Clock frequency	0	35			0	35			MHZ
t _w	Pulse duration	\overline{CLR} low	10			10			ns	
		CLK low	14.5			14.5				
		CLK high	14.5			14.5				
t _{su}	Setup time	Data before CLK↑	15			15			ns	
		\overline{EN} low before CLK↑	10			10				
		CLK high before \overline{EN} ↑‡	15			15				
		\overline{CLR} high (inactive) before CLK↑	10			10				
t _h	Hold time	Data after CLK↑	1			0			ns	
		\overline{EN} low after CLK↑	5			5				
		\overline{RD} high after CLK↑§	5			5				
T _A	Operating free-air temperature	-55	125			0	70			°C

† Applies only to the -1 version and only if V_{CC} is maintained between 4.75 V and 5.25 V

‡ This setup time ensures that \overline{EN} will not false clock the data register.

§ This hold time ensures that there will be no conflict on the input data bus.

SN54ALS996, SN74ALS996

8-BIT D-TYPE EDGE-TRIGGERED READ-BACK LATCHES

SDAS098B – OCTOBER 1984 – REVISED JANUARY 1995

electrical characteristics over recommended operating free-air temperature range (unless otherwise noted)

PARAMETER		TEST CONDITIONS		SN54ALS996		SN74ALS996		UNIT
				MIN	TYP†	MAX	MIN	
V_{IK}		$V_{CC} = 4.5\text{ V}$, $I_I = -18\text{ mA}$		-1.2		-1.2		V
V_{OH}	All outputs	$V_{CC} = 4.5\text{ V to }5.5\text{ V}$, $I_{OH} = -0.4\text{ mA}$		$V_{CC} - 2$		$V_{CC} - 2$		V
	Q	$V_{CC} = 4.5\text{ V}$	$I_{OH} = -1\text{ mA}$	2.4	3.2	2.4	3.2	
V_{OL}	D	$V_{CC} = 4.5\text{ V}$	$I_{OL} = 4\text{ mA}$	0.25	0.4			V
			$I_{OL} = 8\text{ mA}$			0.35	0.5	
	Q	$V_{CC} = 4.5\text{ V}$	$I_{OL} = 12\text{ mA}$	0.25	0.4	0.25	0.4	
			$I_{OL} = 24\text{ mA}$			0.35	0.5	
			$I_{OL} = 48\text{ mA}^\ddagger$			0.35	0.5	
I_{OZH}	Q	$V_{CC} = 5.5\text{ V}$, $V_O = 2.7\text{ V}$		20		20		μA
I_{OZL}	Q	$V_{CC} = 5.5\text{ V}$, $V_O = 0.4\text{ V}$		-20		-20		μA
I_I	D inputs	$V_{CC} = 5.5\text{ V}$		$V_I = 5.5\text{ V}$		0.1		mA
	All others			$V_I = 7\text{ V}$		0.1		
I_{IH}	D inputs §	$V_{CC} = 5.5\text{ V}$, $V_I = 2.7\text{ V}$		20		20		μA
	All others			20		20		
I_{IL}	D inputs §	$V_{CC} = 5.5\text{ V}$, $V_I = 0.4\text{ V}$		-0.1		-0.1		mA
	All others			-0.1		-0.1		
I_{O}^\parallel		$V_{CC} = 5.5\text{ V}$, $CLR = 2.5\text{ V}$		-20	-112	-30	-112	mA
I_{CC}	$V_{CC} = 5.5\text{ V}$, EN, RD low		Outputs high	35	55	35	55	mA
			Outputs low	55	85	55	85	
			Outputs disabled	42	65	42	65	

† All typical values are at $V_{CC} = 5\text{ V}$, $T_A = 25^\circ\text{C}$.

‡ Applies only to the -1 version and only if V_{CC} is maintained between 4.75 V and 5.25 V

§ For I/O ports (Q_A thru Q_H), the parameters I_{IH} and I_{IL} include the off-state output current.

¶ The output conditions have been chosen to produce a current that closely approximates one half of the true short-circuit output current, I_{OS} .



SN54ALS996, SN74ALS996

8-BIT D-TYPE EDGE-TRIGGERED READ-BACK LATCHES

SDAS098B – OCTOBER 1984 – REVISED JANUARY 1995

switching characteristics (see Figure 1)

PARAMETER	FROM (INPUT)	TO (OUTPUT)	V _{CC} = 4.5 V to 5.5 V, C _L = 50 pF, T _A = MIN to MAX†				UNIT
			SN54ALS996		SN74ALS996		
			MIN	MAX	MIN	MAX	
f _{max}			35		35		MHz
t _{PLH}	CLK (T/C = H or L)	Q	5	30	5	28	ns
t _{PHL}			5	24	5	28	
t _{PLH}	CLR (T/C = L)	Q	5	27	7	27	ns
t _{PHL}			5	23	7	23	
t _{PLH}	T/C	Q	4	23	5	23	ns
t _{PHL}			5	23	5	23	
t _{PHL}	CLR	D	5	30	8	30	ns
t _{en} ‡	RD	D	2	18	3	16	ns
t _{dis} §			1	19	3	19	
t _{en} ‡	EN	D	2	17	3	16	ns
t _{dis} §			1	19	3	19	
t _{en} ‡	OE	Q	2	15	4	15	ns
t _{dis} §			1	11	1	10	

† For conditions shown as MIN or MAX, use the appropriate value specified under recommended operating conditions.

‡ t_{en} = t_{PZH} or t_{PZL}

§ t_{dis} = t_{PHZ} or t_{PLZ}



SN54ALS996, SN74ALS996 8-BIT D-TYPE EDGE-TRIGGERED READ-BACK LATCHES

SDAS098B – OCTOBER 1984 – REVISED JANUARY 1995

PARAMETER MEASUREMENT INFORMATION

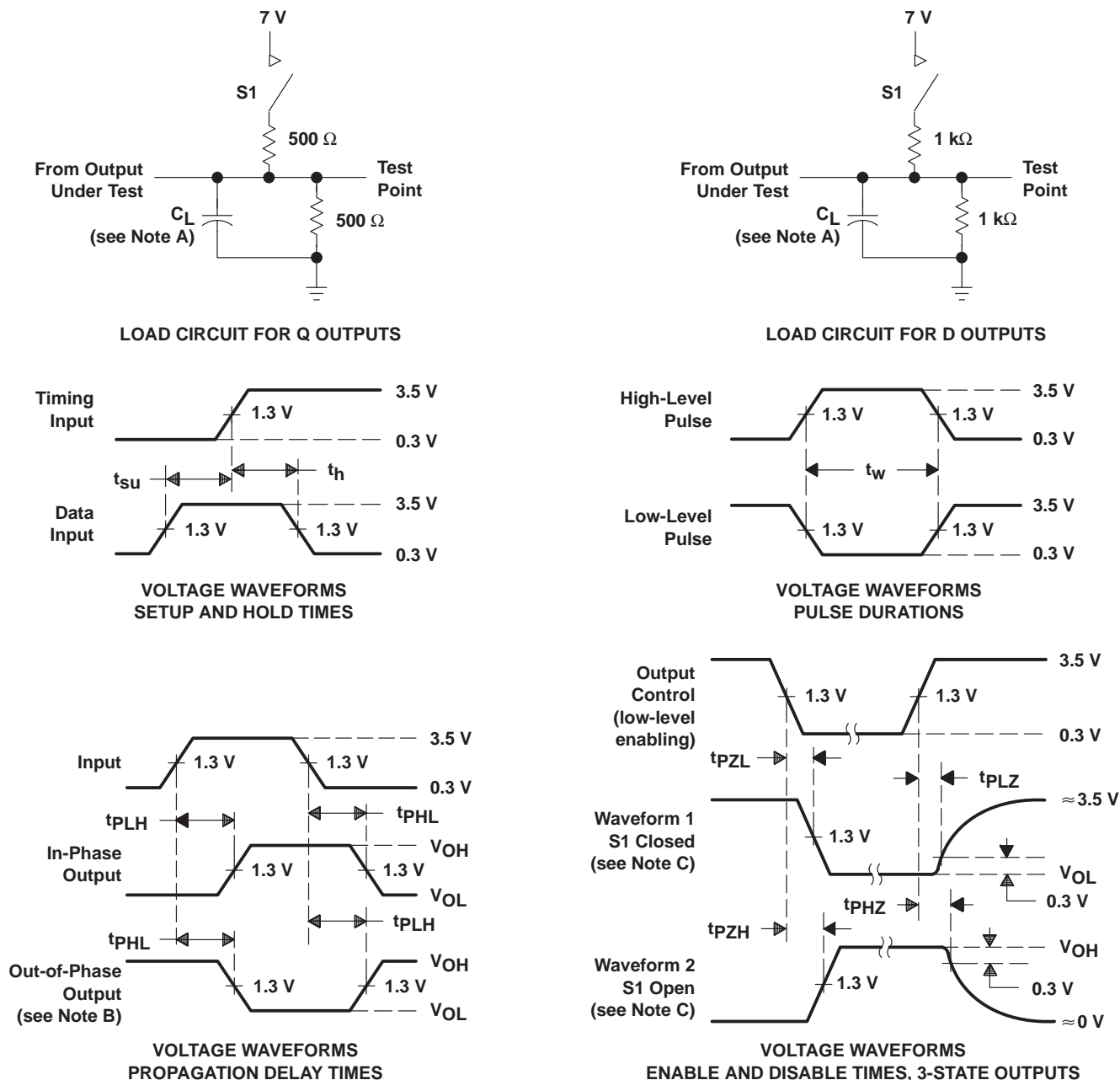

NOTES: A. C_L includes probe and jig capacitance.

B. When measuring propagation delay times of 3-state outputs, switch S1 is open.

C. Waveform 1 is for an output with internal conditions such that the output is low except when disabled by the output control.

Waveform 2 is for an output with internal conditions such that the output is high except when disabled by the output control.

D. All input pulses have the following characteristics: PRR \leq 1 MHz, $t_r = t_f = 2$ ns, duty cycle = 50%.

Figure 1. Load Circuits and Voltage Waveforms

PACKAGING INFORMATION

Orderable part number	Status (1)	Material type (2)	Package Pins	Package qty Carrier	RoHS (3)	Lead finish/ Ball material (4)	MSL rating/ Peak reflow (5)	Op temp (°C)	Part marking (6)
5962-89945013A	Active	Production	LCCC (FK) 28	42 TUBE	No	SNPB	N/A for Pkg Type	-55 to 125	5962- 89945013A SNJ54ALS 996FK
5962-8994501LA	Active	Production	CDIP (JT) 24	15 TUBE	No	SNPB	N/A for Pkg Type	-55 to 125	5962-8994501LA SNJ54ALS996JT
SN74ALS996DW	Obsolete	Production	SOIC (DW) 24	-	-	Call TI	Call TI	0 to 70	
SN74ALS996DWR	Active	Production	SOIC (DW) 24	2000 LARGE T&R	Yes	NIPDAU	Level-1-260C-UNLIM	0 to 70	ALS996
SN74ALS996DWR.A	Active	Production	SOIC (DW) 24	2000 LARGE T&R	Yes	NIPDAU	Level-1-260C-UNLIM	0 to 70	ALS996
SNJ54ALS996FK	Active	Production	LCCC (FK) 28	42 TUBE	No	SNPB	N/A for Pkg Type	-55 to 125	5962- 89945013A SNJ54ALS 996FK
SNJ54ALS996FK.A	Active	Production	LCCC (FK) 28	42 TUBE	No	SNPB	N/A for Pkg Type	-55 to 125	5962- 89945013A SNJ54ALS 996FK
SNJ54ALS996JT	Active	Production	CDIP (JT) 24	15 TUBE	No	SNPB	N/A for Pkg Type	-55 to 125	5962-8994501LA SNJ54ALS996JT
SNJ54ALS996JT.A	Active	Production	CDIP (JT) 24	15 TUBE	No	SNPB	N/A for Pkg Type	-55 to 125	5962-8994501LA SNJ54ALS996JT

(1) **Status:** For more details on status, see our [product life cycle](#).

(2) **Material type:** When designated, preproduction parts are prototypes/experimental devices, and are not yet approved or released for full production. Testing and final process, including without limitation quality assurance, reliability performance testing, and/or process qualification, may not yet be complete, and this item is subject to further changes or possible discontinuation. If available for ordering, purchases will be subject to an additional waiver at checkout, and are intended for early internal evaluation purposes only. These items are sold without warranties of any kind.

(3) **RoHS values:** Yes, No, RoHS Exempt. See the [TI RoHS Statement](#) for additional information and value definition.

(4) **Lead finish/Ball material:** Parts may have multiple material finish options. Finish options are separated by a vertical ruled line. Lead finish/Ball material values may wrap to two lines if the finish value exceeds the maximum column width.

(5) **MSL rating/Peak reflow:** The moisture sensitivity level ratings and peak solder (reflow) temperatures. In the event that a part has multiple moisture sensitivity ratings, only the lowest level per JEDEC standards is shown. Refer to the shipping label for the actual reflow temperature that will be used to mount the part to the printed circuit board.

(6) **Part marking:** There may be an additional marking, which relates to the logo, the lot trace code information, or the environmental category of the part.

Multiple part markings will be inside parentheses. Only one part marking contained in parentheses and separated by a "~" will appear on a part. If a line is indented then it is a continuation of the previous line and the two combined represent the entire part marking for that device.

Important Information and Disclaimer:The information provided on this page represents TI's knowledge and belief as of the date that it is provided. TI bases its knowledge and belief on information provided by third parties, and makes no representation or warranty as to the accuracy of such information. Efforts are underway to better integrate information from third parties. TI has taken and continues to take reasonable steps to provide representative and accurate information but may not have conducted destructive testing or chemical analysis on incoming materials and chemicals. TI and TI suppliers consider certain information to be proprietary, and thus CAS numbers and other limited information may not be available for release.

In no event shall TI's liability arising out of such information exceed the total purchase price of the TI part(s) at issue in this document sold by TI to Customer on an annual basis.

OTHER QUALIFIED VERSIONS OF SN54ALS996, SN74ALS996 :

- Catalog : [SN74ALS996](#)
- Military : [SN54ALS996](#)

NOTE: Qualified Version Definitions:

- Catalog - TI's standard catalog product
- Military - QML certified for Military and Defense Applications

TAPE AND REEL INFORMATION

QUADRANT ASSIGNMENTS FOR PIN 1 ORIENTATION IN TAPE

*All dimensions are nominal

Device	Package Type	Package Drawing	Pins	SPQ	Reel Diameter (mm)	Reel Width W1 (mm)	A0 (mm)	B0 (mm)	K0 (mm)	P1 (mm)	W (mm)	Pin1 Quadrant
SN74ALS996DWR	SOIC	DW	24	2000	330.0	24.4	10.75	15.7	2.7	12.0	24.0	Q1

TAPE AND REEL BOX DIMENSIONS

*All dimensions are nominal

Device	Package Type	Package Drawing	Pins	SPQ	Length (mm)	Width (mm)	Height (mm)
SN74ALS996DWR	SOIC	DW	24	2000	350.0	350.0	43.0

JT (R-GDIP-T**)

CERAMIC DUAL-IN-LINE

24 LEADS SHOWN



- NOTES: A. All linear dimensions are in inches (millimeters).
 B. This drawing is subject to change without notice.
 C. This package can be hermetically sealed with a ceramic lid using glass frit.
 D. Index point is provided on cap for terminal identification.
 E. Falls within MIL STD 1835 GDIP3-T24, GDIP4-T28, and JEDEC MO-058 AA, MO-058 AB

FK (S-CQCC-N**)

LEADLESS CERAMIC CHIP CARRIER

28 TERMINAL SHOWN

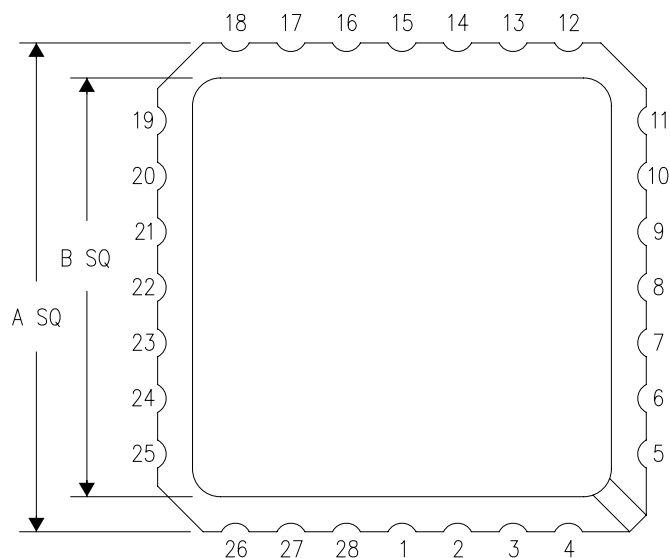

NO. OF TERMINALS **	A		B	
	MIN	MAX	MIN	MAX
20	0.342 (8,69)	0.358 (9,09)	0.307 (7,80)	0.358 (9,09)
28	0.442 (11,23)	0.458 (11,63)	0.406 (10,31)	0.458 (11,63)
44	0.640 (16,26)	0.660 (16,76)	0.495 (12,58)	0.560 (14,22)
52	0.740 (18,78)	0.761 (19,32)	0.495 (12,58)	0.560 (14,22)
68	0.938 (23,83)	0.962 (24,43)	0.850 (21,6)	0.858 (21,8)
84	1.141 (28,99)	1.165 (29,59)	1.047 (26,6)	1.063 (27,0)



4040140/D 01/11

- NOTES:
- All linear dimensions are in inches (millimeters).
 - This drawing is subject to change without notice.
 - This package can be hermetically sealed with a metal lid.
 - Falls within JEDEC MS-004

IMPORTANT NOTICE AND DISCLAIMER

TI PROVIDES TECHNICAL AND RELIABILITY DATA (INCLUDING DATASHEETS), DESIGN RESOURCES (INCLUDING REFERENCE DESIGNS), APPLICATION OR OTHER DESIGN ADVICE, WEB TOOLS, SAFETY INFORMATION, AND OTHER RESOURCES "AS IS" AND WITH ALL FAULTS, AND DISCLAIMS ALL WARRANTIES, EXPRESS AND IMPLIED, INCLUDING WITHOUT LIMITATION ANY IMPLIED WARRANTIES OF MERCHANTABILITY, FITNESS FOR A PARTICULAR PURPOSE OR NON-INFRINGEMENT OF THIRD PARTY INTELLECTUAL PROPERTY RIGHTS.

These resources are intended for skilled developers designing with TI products. You are solely responsible for (1) selecting the appropriate TI products for your application, (2) designing, validating and testing your application, and (3) ensuring your application meets applicable standards, and any other safety, security, regulatory or other requirements.

These resources are subject to change without notice. TI grants you permission to use these resources only for development of an application that uses the TI products described in the resource. Other reproduction and display of these resources is prohibited. No license is granted to any other TI intellectual property right or to any third party intellectual property right. TI disclaims responsibility for, and you fully indemnify TI and its representatives against any claims, damages, costs, losses, and liabilities arising out of your use of these resources.

TI's products are provided subject to [TI's Terms of Sale](#), [TI's General Quality Guidelines](#), or other applicable terms available either on ti.com or provided in conjunction with such TI products. TI's provision of these resources does not expand or otherwise alter TI's applicable warranties or warranty disclaimers for TI products. Unless TI explicitly designates a product as custom or customer-specified, TI products are standard, catalog, general purpose devices.

TI objects to and rejects any additional or different terms you may propose.

Copyright © 2026, Texas Instruments Incorporated

Last updated 10/2025