

## SNx5DP149 3.4Gbps、DP++からHDMIへのリタイマ

### 1 特長

- DisplayPort™物理レイヤ入力ポートからTMDS物理レイヤ出力ポートへ、最高3.4Gbpsのデータ速度をサポート
- DisplayPortのデュアル・モード標準バージョン1.1をサポート
- HDMI1.4bトランスミッタの電気的パラメータをサポート
- 統合TMDSレベル変換器とCDR
- 適応型レシーバ・イコライザと、プログラム可能な固定イコライザ
- ディエンファシスを選択可能
- 低消費電力(標準値)
  - 3.4Gbpsリタイマで390mW
  - シャットダウン状態で10mW
- DVIおよびHDMI識別認識デュアル・モードDP Type 2機能を搭載
- アクティブI<sup>2</sup>C[4]バッファ
- メイン・レーンの入カスワップ
- I<sup>2</sup>C[4]およびピン・ストラップによりプログラム可能
- 工業用温度範囲:  
-40~85°C (SN65DP149)
- 拡張商用温度範囲:  
0~85°C (SN75DP149)
- 40ピン0.4mmピッチ、5mmx5mm WQFN

### 2 アプリケーション

- パーソナル・コンピュータ市場
- 次世代アダプタのドングル
- デスクトップPC
- ノートブックPC市場
- ドッキング・ステーション
- HDTV
- スタンドアロンのビデオ・カード
- タブレット

#### DP149マザーボード・アプリケーションの構造

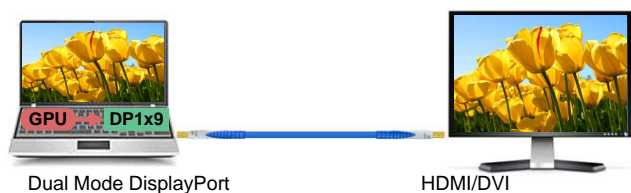

### 3 概要

SNx5DP149デバイスはデュアル・モードの[1] DisplayPortからTMDS (Transition-Minimized Differential Signal)へのリタイマで、DVI (Digital Video Interface) 1.0およびHDMI (High-Definition Multimedia Interface) 1.4b出力信号をサポートします。SNx5DP149デバイスは、DDCリンクにより、デュアル・モード標準バージョン1.1 type 1およびtype 2をサポートします。SNx5DP149デバイスは、データ・レーンごとに最高3.4Gbpsのデータ速度をサポートし、カラーごとに8ビットの高解像度Ultra HD (4Kx2K/30Hz)ビデオ、および1080p (1920x1080/60Hz)で16ビット・カラー深度のHDTVをサポートします。SNx5DP149デバイスは、データ速度が1Gbps未満のときはリドライバとして、データ速度がそれ以上の場合はリタイマとして、自動的に自己構成可能です。この機能は、I<sup>2</sup>C[4]のプログラムによりオフにできません。

信号の整合性のため、SNx5DP149デバイスにはいくつかの機能が実装されています。SNx5DP149レシーバは適応型と固定の両方のイコライゼーションをサポートし、シンボル間干渉(ISI)ジッタや、帯域幅の制限された基板配線やケーブルによる損失をクリーンアップできます。リタイマとして動作するとき、組み込みのクロック・データ・リカバリ(CDR)により、ビデオ・ソース入力の高周波とランダムなジッタがクリーンアップされます。トランスミッタには、コンプライアンスに適合し、ディエンファシスなどシステム・レベルの設計の問題を低減するためいくつかの機能があり、長いケーブルや損失の大きい基板配線を駆動するときの減衰を補償します。

#### 製品情報<sup>(1)</sup>

型番	パッケージ	本体サイズ(公称)
SN65DP149 SN75DP149	WQFN (40)	5.00mmx5.00mm

(1) 利用可能なすべてのパッケージについては、このデータシートの末尾にある注文情報を参照してください。

#### DP149ドングル・アプリケーションの構造

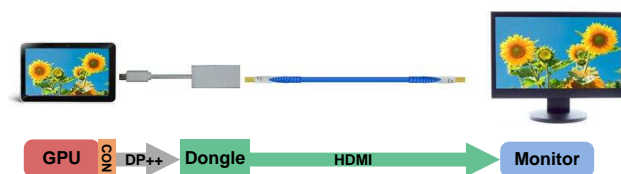

## 目次

1	特長	1	9.1	Overview	21
2	アプリケーション	1	9.2	Functional Block Diagram	21
3	概要	1	9.3	Feature Description	22
4	改訂履歴	2	9.4	Device Functional Modes	27
5	概要(続き)	3	9.5	Register Maps	29
6	Pin Configuration and Functions	3	10	Application and Implementation	37
7	Specifications	6	10.1	Application Information	37
7.1	Absolute Maximum Ratings	6	10.2	Typical Application	41
7.2	ESD Ratings	6	10.3	System Example	43
7.3	Recommended Operating Conditions	7	11	Power Supply Recommendations	44
7.4	Thermal Information	7	11.1	Power Management	44
7.5	Power Supply Electrical Characteristics	8	12	Layout	44
7.6	Differential Input Electrical Characteristics	9	12.1	Layout Guidelines	44
7.7	HDMI and DVI TMDS Output Electrical Characteristics	10	12.2	Layout Example	46
7.8	DDC, and I <sup>2</sup> C Electrical Characteristics	11	12.3	Thermal Considerations	46
7.9	HPD Electrical Characteristics	11	13	デバイスおよびドキュメントのサポート	46
7.10	HDMI and DVI Main Link Switching Characteristics	12	13.1	関連リンク	46
7.11	HPD Switching Characteristics	12	13.2	ドキュメントのサポート	47
7.12	DDC and I <sup>2</sup> C Switching Characteristics	13	13.3	ドキュメントの更新通知を受け取る方法	47
7.13	Typical Characteristics	14	13.4	コミュニティ・リソース	47
8	Parameter Measurement Information	14	13.5	商標	47
9	Detailed Description	21	13.6	静電気放電に関する注意事項	47
			13.7	Glossary	47
			14	メカニカル、パッケージ、および注文情報	47

## 4 改訂履歴

資料番号末尾の英字は改訂を表しています。その改訂履歴は英語版に準じています。

Revision B (April 2016) から Revision C に変更	Page
• <a href="#">Recommended Operating Conditions</a> , Changed the CONTROL PINS section	7
• Changed the <a href="#">DDC, and I<sup>2</sup>C Electrical Characteristics</a> table	11

Revision A (December 2015) から Revision B に変更	Page
• Added "Low-level input voltage at OE" to V <sub>IL</sub> in the <a href="#">Recommended Operating Conditions</a> table	7
• Added OE to V <sub>IH</sub> "High-level input voltage" in the <a href="#">Recommended Operating Conditions</a> table	7

2015年9月発行のものから更新	Page
• Added new table note for V <sub>IL</sub> , V <sub>IM</sub> , and V <sub>IH</sub>	7
• Changed VSADJ Resistor Value from 7.06k to 6.5K	8
• Removed AUX column	44

## 5 概要 (続き)

SNx5DP149デバイスには、Vsadjピンの外付け抵抗によるTMDS出力振幅設定、ソース終端の選択、および出力スlewレート制御機能も搭載されています。デバイスの動作および構成は、ピン・ストラッピングまたはI<sup>2</sup>Cによりプログラム可能です[4]。

SNx5DP149デバイスには、電力管理およびアクティブな消費電力削減のため、いくつかの手法が実装されています。

SNx5DP149レシーバは、スペースに制約のあるアプリケーション向けの40ピンRSBで供給されます。

SN75DP149デバイスは、工業用動作温度範囲の-40°C～85°Cで動作が規定されています。

SN65DP149デバイスは、商業用動作温度範囲の0°C～85°Cで動作が規定されています。

## 6 Pin Configuration and Functions

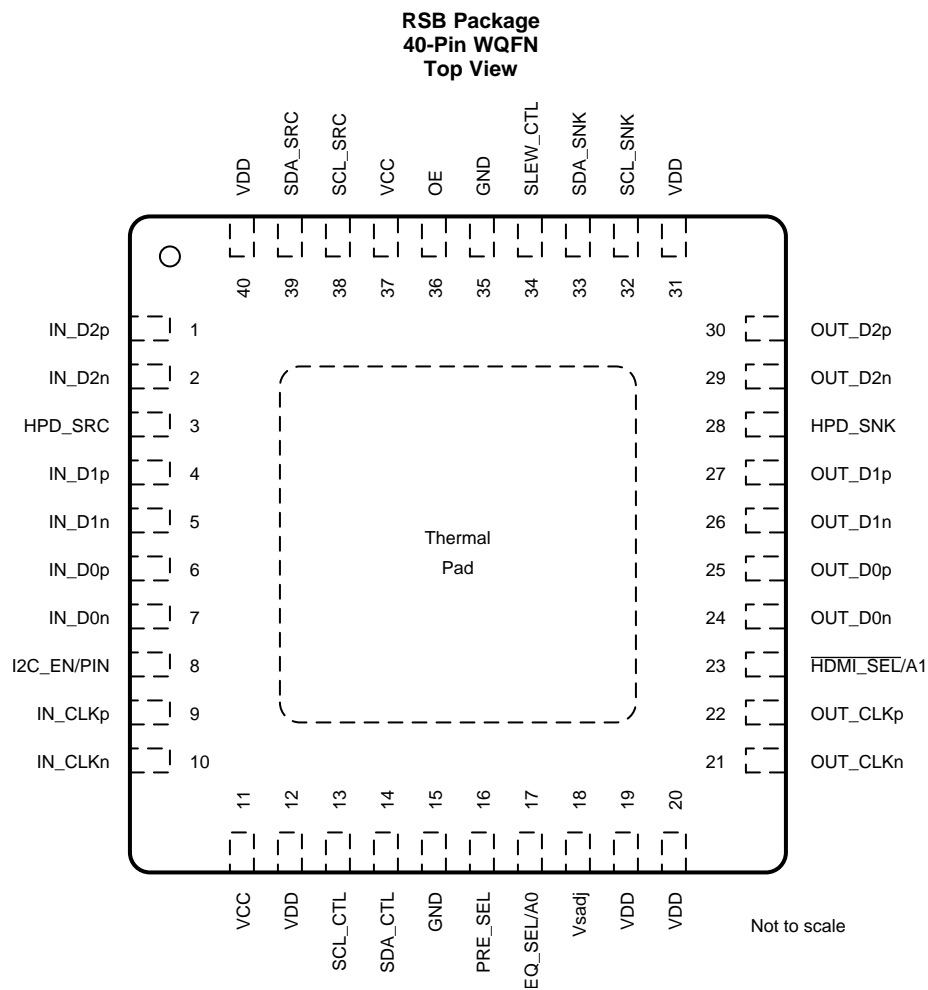

### Pin Functions

PIN		I/O	DESCRIPTION <sup>(1)</sup>
SIGNAL NAME	NO.		
<b>MAIN LINK INPUT PINS (FAIL SAFE)</b>			
IN_D2p	1	I	Channel 2 differential input
IN_D2n	2		

(1) (H) Logic high (pin strapped to VCC through 65-kΩ resistor); (L) logic low (pin strapped to GND through 65-kΩ resistor); (for mid-level, no connect)

**Pin Functions (continued)**

PIN		I/O	DESCRIPTION <sup>(1)</sup>
SIGNAL NAME	NO.		
IN_D1p IN_D1n	4 5	I	Channel 1 differential input
IN_D0p IN_D0n	6 7	I	Channel 0 differential input
IN_CLKp IN_CLKn	9 10	I	Clock differential input

**Pin Functions (continued)**

PIN		I/O	DESCRIPTION <sup>(1)</sup>
SIGNAL NAME	NO.		
<b>MAIN LINK OUTPUT PINS (FAIL SAFE)</b>			
OUT_D2n	29	O	TMDS data 2 differential output
OUT_D2p	30		
OUT_D1n	26	O	TMDS data 1 differential output
OUT_D1p	27		
OUT_D0n	24	O	TMDS data 0 differential output
OUT_D0p	25		
OUT_CLKn	21	O	TMDS data clock differential output
OUT_CLKp	22		
<b>HOT PLUG DETECT PINS</b>			
HPD_SRC	3	O	Hot plug detect output
HPD_SNK	28	I (Failsafe)	Hot plug detect input
<b>DDC DATA PINS</b>			
SDA_SRC	39	I/O (Failsafe)	Source side TMDS port bidirectional DDC data line
SCL_SRC	38		
SDA_SNK	33	I/O (Failsafe)	Sink side TMDS port bidirectional DDC data lines
SCL_SNK	32		
<b>CONTROL PINS</b>			
OE	36	I	Operation enable/reset pin OE = L: Power-down mode OE = H: Normal operation Internal weak pullup: Resets device when transitions from H to L
SLEW_CTL	34	I 3 level <sup>(1)</sup>	Slew rate control when I2C_EN/PIN = Low. SLEW_CTL = H, fastest data rate (default) SLEW_CTL = L, 5-ps slow SLEW_CTL = No Connect, 10-ps slow When I2C_EN/PIN = High Slew rate is controlled through I <sup>2</sup> C[4]
PRE_SEL	16	I 3 level <sup>(1)</sup>	PRE_SEL = L: -2-dB de-emphasis PRE_SEL = No Connect: 0-dB PRE_SEL = H: Reserved Note: (3 level for pin strap programming, but 2 level when I <sup>2</sup> C[4] address)
EQ_SEL/A0	17	I 3 level <sup>(1)</sup>	Input Receive Equalization pin strap when I2C_EN/PIN = Low EQ_SEL = L: Fixed EQ at 7.5-dB EQ_SEL = No Connect: Adaptive EQ EQ_SEL = H: Fixed at 14-dB When I2C_EN/PIN = High Address bit 1 Note: (3 level for pin strap programming but 2 level when I <sup>2</sup> C[4] address)
I2C_EN/PIN	8	I	I2C_EN/PIN = High; puts device into I <sup>2</sup> C control mode I2C_EN/PIN = Low; puts device into pin strap mode
SCL_CTL	13	I	I <sup>2</sup> C clock signal Note: When I2C_EN/PIN = Low Pin strapping take priority and those functions cannot be changed by I <sup>2</sup> C
SDA_CTL	14	I/O	I <sup>2</sup> C data signal Note: When I2C_EN/PIN = Low Pin strapping take priority and those functions cannot be changed by I <sup>2</sup> C
Vsadj	18	I	TMDS-compliant voltage swing control nominal resistor to GND
HDMI_SEL/A1	23	I	HDMI_SEL when I2C_EN/PIN = Low HDMI_SEL = High: Device configured for DVI HDMI_SEL = Low: Device configured for HDMI (Adaptor ID block is readable through I <sup>2</sup> C When I2C_EN/PIN = High Address bit 2 Note: Weak internal pull down
<b>SUPPLY AND GROUND PINS</b>			
V <sub>CC</sub>	11, 37	P	3.3-V power supply
V <sub>DD</sub>	12, 19, 20, 31, 40	P	1.1-V power supply

**Pin Functions (continued)**

PIN		I/O	DESCRIPTION <sup>(1)</sup>
SIGNAL NAME	NO.		
GND	15, 35, Thermal Pad	—	Ground

## 7 Specifications

### 7.1 Absolute Maximum Ratings

 over operating free-air temperature (unless otherwise noted) <sup>(1)(2)</sup>

		MIN	MAX	UNIT
Supply voltage <sup>(3)</sup>	V <sub>CC</sub>	−0.3	4	V
	V <sub>DD</sub>	−0.3	1.4	V
Voltage	Main link input (IN_Dx AC-coupled mode)		1.56	V
	TMDS outputs (OUT_Dx)	−0.3	4	V
	HPD_SRC, Vsadj, SDA_CTL, SCL_CTL, OE, HDMI_SEL/A1, EQ_SEL/A0, I2C_EN/PIN, SLEW_CTL, SDA_SRC, SCL_SRC	−0.3	4	V
	HPD_SNK, SDA_SNK, SCL_SNK	−0.3	6	V
Continuous power dissipation		See <a href="#">Thermal Information</a>		
Storage temperature, T <sub>stg</sub>		−65	150	°C

- (1) Stresses beyond those listed under *Absolute Maximum Ratings* may cause permanent damage to the device. These are stress ratings only and functional operation of the device at these or any conditions beyond those indicated under *Recommended Operating Conditions* is not implied. Exposure to absolute-maximum-rated conditions for extended periods may affect device reliability.
- (2) All voltage values, except differential voltages, are with respect to network ground terminal.
- (3) Tested in accordance with JEDEC Standard 22, Test Method A114-B.

### 7.2 ESD Ratings

			VALUE	UNIT
V <sub>(ESD)</sub>	Electrostatic discharge	Human body model (HBM), per ANSI/ESDA/JEDEC JS-001, all pins <sup>(1)</sup>	±2000	V
		Charged device model (CDM), per JEDEC specification JESD22-C101, all pins <sup>(2)</sup>	±500	V

- (1) JEDEC document JEP155 states that 500-V HBM allows safe manufacturing with a standard ESD control process.
- (2) JEDEC document JEP157 states that 250-V CDM allows safe manufacturing with a standard ESD control process.

### 7.3 Recommended Operating Conditions

over operating free-air temperature range (unless otherwise noted)

		MIN	NOM	MAX	UNIT
<b>GENERAL PARAMETERS</b>					
$V_{CC}$	Supply voltage	3	3.3	3.6	V
$V_{DD}$		1.00	1.1	1.27	
$T_{CASE}$	Case temperature for RSB package			93.5	°C
$T_A$	Operating free-air temperature	SN75DP149		85	°C
		SN65DP149	-40	85	
<b>MAIN LINK DIFFERENTIAL PINS</b>					
$V_{ID\_PP}$	Peak-to-peak input differential voltage	75		1200	mv
$V_{IC}$	Input common mode voltage	0		2	V
$C_{AC}$	AC coupling capacitance	75	100	200	nF
$d_R$	Data rate	0.25		5	Gbps
$V_{sadj}$	TMDS-compliant swing voltage bias resistor		6.5		k $\Omega$
<b>CONTROL PINS</b>					
$V_{I\_DC}$	DC input voltage	-0.3		3.6	V
$V_{IL}^{(1)}$	Low-level input voltage at OE			0.8	V
	Low-level input voltage at SLEW_CTL, PRE_SEL, EQ_SEL/A0, SWAP/POL			0.3	
$V_{IM}^{(1)}$	No connect input voltage at SLEW_CTL, PRE_SEL, EQ_SEL/A0, SWAP/POL	1	1.2	1.4	V
$V_{IH}^{(1)}$	High-level input voltage at SLEW_CTL, OE <sup>(2)</sup> , PRE_SEL, EQ_SEL/A0, SWAP/POL	2.6			V
$V_{OL}$	Low-level output voltage			0.4	V
$V_{OH}$	High-level output voltage	2.4			V
$I_{IH}$	High-level input current	-30		30	$\mu$ A
$I_{IL}$	Low-level input current	-10		10	$\mu$ A
$I_{OS}$	Short circuit output current	-50		50	mA
$I_{OZ}$	High impedance output current			10	$\mu$ A
$R_{OEPU}$	Pullup resistance on OE pin	150		250	k $\Omega$

- (1) These values are based upon a microcontroller driving the control pins. The pullup/pulldown/floating resistor configuration will set the internal bias to the proper voltage level which will not match the values shown here.
- (2) This value is based upon a microcontroller driving the OE pin. A passive reset circuit using an external capacitor and the internal pullup resistor will set OE pin properly, but may have a different value than shown due to internal biasing.

### 7.4 Thermal Information

over operating free-air temperature range (unless otherwise noted)

THERMAL METRIC <sup>(1)</sup>		SNx5DP149	UNIT
		RSB (WQFN)	
		40 PINS	
$R_{\theta JA}$	Junction-to-ambient thermal resistance	37.3	°C/W
$R_{\theta JB}$	Junction-to-board thermal resistance (High-K board <sup>(2)</sup> )	9.9	°C/W
$R_{\theta JC(top)}$	Junction-to-case (top) thermal resistance (High-K board <sup>(2)</sup> )	23.1	°C/W
$R_{\theta JC(bot)}$	Junction-to-case (bottom) thermal resistance	3.2	°C/W
$\Psi_{JT}$	Junction-to-top characterization parameter	0.3	°C/W
$\Psi_{JB}$	Junction-to-case (bottom) thermal resistance	3.2	°C/W

- (1) For more information about traditional and new thermal metrics, see the [Semiconductor and IC Package Thermal Metrics](#) application report.
- (2) Test conditions for  $\Psi_{JB}$  and  $\Psi_{JT}$  are clarified in TI document [Semiconductor and IC Package Thermal Metrics](#).

## 7.5 Power Supply Electrical Characteristics

over recommended operating free-air temperature range (unless otherwise noted)

PARAMETER		TEST CONDITIONS	MIN	TYP <sup>(1)</sup>	MAX	UNIT
$P_{D1}$	Device power dissipation (retimer mode)	OE = H, $\overline{\text{HDMI\_SEL}} = \text{L}$ , $V_{CC} = 3.3/3.6\text{-V}$ , $V_{DD} = 1.1/1.27\text{-V}$ , $V_{Sadj} = 6.5\text{-k}\Omega$ IN_Dx: $V_{ID\_PP} = 1200\text{-mV}$ , 3.4-Gbps TMDS pattern AUX: $V_I = 3.3\text{-V}$ I2C_EN/PIN = L, PRE_SEL = H, IN_EQ_CTL = H, SDA_CTL/CLK_CTL = 0-V		390	510	mW
$P_{D2}$	Device power dissipation (redriver mode)	OE = H, $\overline{\text{HDMI\_SEL}} = \text{L}$ , $V_{CC} = 3.3/3.6\text{-V}$ , $V_{DD} = 1.1/1.27\text{-V}$ , $V_{Sadj} = 6.5\text{-k}\Omega$ IN_Dx: $V_{ID\_PP} = 1200\text{-mV}$ , 3.4-Gbps TMDS pattern AUX: $V_I = 3.3\text{-V}$ I2C_EN/PIN = L, PRE_SEL = H, IN_EQ_CTL = H, SDA_CTL/CLK_CTL = 0-V		225	350	mW
$P_{SD1}$	Device power with shut down OE = L	OE = L, $V_{CC} = 3.3/3.6\text{ V}$ , $V_{DD} = 1.1/1.27\text{ V}$ , $V_{Sadj} = 7.06\text{ k}\Omega$		5	15	mW
$I_{DD1}$	$V_{DD}$ Supply current (TMDS 3.4-Gpbs retimer mode)	OE = H, $\overline{\text{HDMI\_SEL}} = \text{L}$ , $V_{CC} = 3.3/3.6\text{-V}$ , $V_{DD} = 1.1/1.27\text{-V}$ , $V_{Sadj} = 6.5\text{-k}\Omega$ IN_Dx: $V_{ID\_PP} = 1200\text{-mV}$ , 3.4-Gbps TMDS pattern AUX: $V_I = 3.3\text{-V}$ , 100-kHz PRBS I2C_EN/PIN = L, PRE_SEL = H, IN_EQ_CTL = H, SDA_CTL/CLK_CTL = 0 V, SLEW_CTL = H		250	300	mA
$I_{CC1}$	$V_{CC}$ Supply current (TMDS 3.4-Gpbs retimer mode)	OE = H, $\overline{\text{HDMI\_SEL}} = \text{L}$ , $V_{CC} = 3.3/3.6\text{-V}$ , $V_{DD} = 1.1/1.27\text{-V}$ , $V_{Sadj} = 6.5\text{-k}\Omega$ IN_Dx: $V_{ID\_PP} = 1200\text{-mV}$ , 3.4-Gbps TMDS pattern AUX: $V_I = 3.3\text{-V}$ , 100-kHz PRBS I2C_EN/PIN = L, PRE_SEL = H, IN_EQ_CTL = H, SDA_CTL/CLK_CTL = 0 V, SLEW_CTL = H		35	50	mA
$I_{DD2}$	$V_{DD}$ Supply current (TMDS 3.4-Gpbs redriver mode)	OE = H, $\overline{\text{HDMI\_SEL}} = \text{L}$ , $V_{CC} = 3.3/3.6\text{-V}$ , $V_{DD} = 1.1/1.27\text{-V}$ , $V_{Sadj} = 6.5\text{-k}\Omega$ IN_Dx: $V_{ID\_PP} = 1200\text{-mV}$ , 3.4-Gbps TMDS pattern AUX: $V_I = 3.3\text{-V}$ , 100-kHz PRBS I2C_EN/PIN = L, PRE_SEL = H, IN_EQ_CTL = H, SDA_CTL/CLK_CTL = 0 V, SLEW_CTL = H		170	200	mA
$I_{CC2}$	$V_{CC}$ Supply current (TMDS 3.4-Gpbs redriver mode)	OE = H, $\overline{\text{HDMI\_SEL}} = \text{L}$ , $V_{CC} = 3.3/3.6\text{-V}$ , $V_{DD} = 1.1/1.27\text{-V}$ , $V_{Sadj} = 6.5\text{-k}\Omega$ IN_Dx: $V_{ID\_PP} = 1200\text{-mV}$ , 3.4-Gbps TMDS pattern AUX: $V_I = 3.3\text{-V}$ , 100-kHz PRBS I2C_EN/PIN = L, PRE_SEL = H, IN_EQ_CTL = H, SDA_CTL/CLK_CTL = 0 V, SLEW_CTL = H		8	20	mA
$I_{SD1}$	$V_{DD}$ Shutdown current	OE = L, $V_{CC} = 3.3/3.6\text{-V}$ , $V_{DD} = 1.1/1.27\text{-V}$ , $V_{Sadj} = 6.5\text{-k}\Omega$		3	10.5	mA
$I_{SD1}$	$V_{CC}$ Shutdown current	OE = L, $V_{CC} = 3.3/3.6\text{-V}$ , $V_{DD} = 1.1/1.27\text{-V}$ , $V_{Sadj} = 6.5\text{-k}\Omega$		2	5	mA

 (1) The typical rating is simulated at 3.3-V  $V_{CC}$  and 1.1-V  $V_{DD}$  and at 27°C temperature unless otherwise noted

## 7.6 Differential Input Electrical Characteristics

over recommended operating free-air temperature range (unless otherwise noted)

PARAMETER		TEST CONDITIONS	MIN	TYP	MAX	UNIT
D <sub>R_RX_DATA</sub>	Ddata lanes data rate		0.25		3.4	Gbps
D <sub>R_RX_CLK</sub>	Clock lanes clock rate		25		340	MHz
t <sub>RX_DUTY</sub>	Input clock duty circle		40%	50%	60%	
t <sub>CLK_JIT</sub>	Input clock jitter tolerance				0.3	Tbit
t <sub>DATA_JIT</sub>	Input data jitter tolerance	Test the TTP2, see <a href="#">10</a>			150	ps
T <sub>RX_INTRA</sub>	Input intra-pair skew tolerance	Test at TTP2 when DR = 1.6-Gbps, see <a href="#">10</a>	112			ps
T <sub>RX_INTER</sub>	Input inter-pair skew tolerance				1.8	ns
E <sub>QH(D)</sub>	Fixed EQ gain for data lane IN <sub>D</sub> (0,1,2)n/p	EQ_SEL/A0 = H; Fixed EQ gain, test at 3.4-Gbps		14		dB
E <sub>QL(D)</sub>	Fixed EQ gain for data lane IN <sub>D</sub> (0,1,2)n/p	EQ_SEL/A0 = L; Fixed EQ gain, test at 3.4-Gbps		7.5		dB
E <sub>QZ(D)</sub>	Adaptive EQ gain for data lane IN <sub>D</sub> (0,1,2)n/p	EQ_SEL/A0 = Z; adaptive EQ	2		14	dB
E <sub>Q(c)</sub>	EQ gain for clock lane IN <sub>CLK</sub> n/p	EQ_SEL/A0 = H,L,NC		3		
R <sub>INT</sub>	Input differential termination impedance		80	100	120	Ω
V <sub>ITERM</sub>	Input termination voltage	OE = H		0.7		V
V <sub>ID_PP</sub>	Input differential voltage (peak to peak)	Tested at TTP2, check <a href="#">10</a>	75		1200	mV <sub>PP</sub>

## 7.7 HDMI and DVI TMD5 Output Electrical Characteristics

over recommended operating free-air temperature range (unless otherwise noted)

PARAMETER	TEST CONDITIONS	MIN	TYP	MAX	UNIT	
V <sub>OH</sub>	Single-ended high level output voltage	Data rate ≤ 1.65 Gbps; PRE_SEL = NC; SLEW_CTL = H; OE = H; DR = 750 Mbps, VSadj = 7.06 kΩ	V <sub>CC</sub> – 10		V <sub>CC</sub> + 10	mV
		1.65 Gbps < Data rate ≤ 3.4 Gbps; PRE_SEL = NC; SLEW_CTL = H; OE = H; DR = 2.97 Gbps, VSadj = 7.06 kΩ	V <sub>CC</sub> – 200		V <sub>CC</sub> + 10	
V <sub>OL</sub>	Single-ended low level output voltage	Data rate ≤ 1.65 Gbps; PRE_SEL = NC; SLEW_CTL = H; OE = H; DR = 750 Mbps, VSadj = 6.5 kΩ	V <sub>CC</sub> – 600		V <sub>CC</sub> – 400	mV
		1.65-Gbps < Data rate ≤ 3.4-Gbps; PRE_SEL = NC; SLEW_CTL = H; OE = H; DR = 2.97-Gbps, VSadj = 6.5 kΩ	V <sub>CC</sub> – 700		V <sub>CC</sub> – 400	
V <sub>SWING_DA</sub>	Single-ended output voltage swing on data lane	PRE_SEL = NC; SLEW_CTL = H; OE = H; DR = 270-Mbs/2.97 VSadj = 6.5 kΩ	400	500	600	mV
V <sub>SWING_CLK</sub>	Single-ended output voltage swing on clock lane	Data rate ≤ 3.4-Gbps; PRE_SEL = NC; SLEW_CTL = H; OE = H; VSadj = 6.5 kΩ	400	500	600	mV
ΔV <sub>SWING</sub>	Change in single-end output voltage swing per 100 Ω ΔVsadj		20			mV
ΔV <sub>OCM(SS)</sub>	Change in steady state output common mode voltage between logic levels		–5		5	mV
V <sub>OD(PP)</sub>	Output differential voltage before pre-emphasis	VSadj = 7.06 kΩ; PRE_SEL = Z, See <a href="#">8</a>	800		1200	mV
V <sub>OD(SS)</sub>	Steady-state output differential voltage	VSadj = 7.06 kΩ; PRE_SEL = L, See <a href="#">9</a>	600		1050	mV
I <sub>LEAK</sub>	Failsafe condition leakage current	V <sub>CC</sub> = 0 V; V <sub>DD</sub> = 0-V; output pulled to 3.3 V through 50-Ω resistors			45	μA
I <sub>OS</sub>	Short circuit current limit	Main link output shorted to GND			50	mA
R <sub>TERM</sub>	Source termination resistance for HDMI 2.0		75		150	Ω

## 7.8 DDC, and I<sup>2</sup>C Electrical Characteristics

over recommended operating free-air temperature range (unless otherwise noted)

PARAMETER		TEST CONDITIONS	MIN	TYP	MAX	UNIT
V <sub>I-DC</sub>	SCL/SDA_SNK DC input voltage		-0.3		5.6	V
	SCL/SDA_CTL, SCL/SDA_SRC DC input voltage		-0.3		3.6	V
V <sub>IL</sub>	SCL/SDA_SNK, SCL/SDA_SRC Low level input voltage				0.3 x V <sub>CC</sub>	V
	SCL/SDA_CTL Low level input voltage				0.3 x V <sub>CC</sub>	V
V <sub>IH</sub>	SCL/SDA_SNK high level input voltage		3			V
	SCL/SDA_SRC high level input voltage		0.7 x V <sub>CC</sub>			V
	SCL/SDA_CTL high level input voltage		0.7 x V <sub>CC</sub>			V
V <sub>OL</sub>	SCL/SDA_CTL, SCL/SDA_SRC low-level output voltage	I <sub>0</sub> = 3 mA and V <sub>CC</sub> > 2-V			0.4	V
		I <sub>0</sub> = 3 mA and V <sub>CC</sub> < 2-V			0.2 x V <sub>CC</sub>	V
f <sub>SCL</sub>	SCL clock frequency fast I2C mode for local I2C control				400	kHz
C <sub>bus</sub>	Total capacitive load for each bus line (DDC and local I2C pins)				400	pF

## 7.9 HPD Electrical Characteristics

over operating free-air temperature range (unless otherwise noted)

PARAMETER		TEST CONDITIONS	MIN	TYP	MAX	UNIT
V <sub>IH</sub>	High-level input voltage	HPD_SNK	2.1			V
V <sub>IL</sub>	Low-level input voltage	HPD_SNK			0.8	V
V <sub>OH</sub>	High-level output voltage	I <sub>OH</sub> = -50 μA; HPD_SRC	2.4		3.6	V
V <sub>OL</sub>	Low-level output voltage	I <sub>OL</sub> = 500 μA; HPD_SRC	0		0.1	V
I <sub>LEAK</sub>	Failsafe condition leakage current	V <sub>CC</sub> = 0 V; V <sub>DD</sub> = 0 V; HPD_SNK = 5 V			40	μA
I <sub>H-HPD</sub>	High-level input current	Device powered; V <sub>IH</sub> = 5 V; I <sub>H-HPD</sub> includes R <sub>pdHPD</sub> resistor current			40	μA
I <sub>L-HPD</sub>	Low-level input current	Device powered; V <sub>IL</sub> = 0.8 V; I <sub>L-HPD</sub> includes R <sub>pdHPD</sub> resistor current			30	μA
R <sub>pdHPD</sub>	HPD input termination to GND	V <sub>CC</sub> = 0 V	150	190	220	kΩ

## 7.10 HDMI and DVI Main Link Switching Characteristics

over recommended operating free-air temperature range (unless otherwise noted)

PARAMETER		TEST CONDITIONS	MIN	TYP	MAX	UNIT
<b>REDRIVER MODE</b>						
$D_R$	Data rate (Automatic Mode)		250		1000	Mbps
$D_R$	Data rate (full redriver mode)		250		3400	Mbps
$t_{PLH}$	Propagation delay time (low to high)		250		600	ps
$t_{PHL}$	Propagation delay time (high to low)		250		800	ps
$t_{T1}$	Transition time (rise and fall time); measured at 20% and 80% levels for data lanes. TMDS clock meets $t_{T3}$ for all three times.	SLEW_CTL = H; PRE_SEL = NC; OE = H; DR = 2.97 Gbps	75			ps
$t_{T2}$		SLEW_CTL = L; PRE_SEL = NC; OE = H; DR = 2.97 Gbps	75			
$t_{T3}$		SLEW_CTL = NC; PRE_SEL = NC; OE = H; DR = 2.97 Gbps; CLK 297MHz	100			
$t_{SK1(T)}$	Intra-pair output skew	SLEW_CTL = NC; PRE_SEL = NC; OE = H; DR = 2.97 Gbps;			40	ps
$t_{SK2(T)}$	Inter-pair output skew	SLEW_CTL = NC; PRE_SEL = NC; OE = H; DR = 2.97 Gbps;			100	ps
$t_{JTD1}$	Total output data jitter	DR = 2.97 Gbps, HDMI_SEL/A1 = NC, EQ_SEL/A0 = NC; PRE_SEL = NC; SLEW_CTL = H OE = H. See <a href="#">10</a> at TTP3			0.2	Tbit
$t_{JTC1}$	Total output clock jitter	CLK = 297 MHz			0.25	Tbit
<b>RETIMER MODE</b>						
$d_R$	Data rate (Full retimer mode)		0.25		3.4	Gbps
$d_R$	Data rate (Automatic mode)		1.0		3.4	Gbps
$d_{XVR}$	Automatic redriver to retimer crossover	Measured with input signal applied from 0 to 200 mVpp	.75	1.0	1.25	Gbps
$f_{CROSSOVER}$	Crossover frequency hysteresis			250		MHz
$P_{LLBW}$	Data retimer PLL bandwidth	Default loop bandwidth setting		.4	1	MHz
$t_{ACQ}$	Input clock frequency detection and retimer acquisition time			180		$\mu$ s
$I_{JT1}$	Input clock jitter tolerance	Tested when data rate > 1.0 Gbps			0.3	Tbit
$t_{T1}$	Transition time (rise and fall time); measured at 20% and 80% levels for data lanes. TMDS clock meets $t_{T3}$ for all three times.	SLEW_CTL = H; PRE_SEL = NC; OE = H; DR = 3.4 Gbps	75			ps
$t_{T2}$		SLEW_CTL = L; PRE_SEL = NC; OE = H; DR = 3.4 Gbps	75			
$t_{T3}$		SLEW_CTL = NC; PRE_SEL = NC; OE = H; DR = 3.4 Gbps; CLK = 297 MHz	100			
$t_{DCD}$	OUT_CLK $\pm$ duty cycle		40%	50%	60%	
$t_{SK\_INTER}$	Inter-pair output skew	Default setting for internal inter-pair skew adjust, HDMI_SEL/A1 = NC			0.2	Tch
$t_{SK\_INTRA}$					0.15	Tbit
$t_{JTC1(1.4b)}$	Total output clock jitter	CLK = 297 MHz			0.25	Tbit

## 7.11 HPD Switching Characteristics

over recommended operating free-air temperature range (unless otherwise noted)

PARAMETER	TEST CONDITIONS	MIN	TYP	MAX	UNIT
$t_{PD(HPD)}$	Propagation delay from HPD_SNK to HPD_SRC; rising edge and falling edge	See <a href="#">13</a> ; not valid during switching time	40	120	ns
$t_{T(HPD)}$	HPD logical disconnected timeout	See <a href="#">14</a>	2		ms

## 7.12 DDC and I<sup>2</sup>C Switching Characteristics

over recommended operating free-air temperature range (unless otherwise noted)

PARAMETER		TEST CONDITIONS	MIN	TYP	MAX	UNIT
$t_r$	Rise time of both SDA and SCL signals	$V_{CC} = 3.3\text{-V}$			300	ns
$t_f$	Fall time of both SDA and SCL signals				300	ns
$t_{HIGH}$	Pulse duration, SCL high		0.6			$\mu\text{s}$
$t_{LOW}$	Pulse duration, SCL low		1.3			$\mu\text{s}$
$t_{SU1}$	Setup time, SDA to SCL		100			ns
$t_{ST, STA}$	Setup time, SCL to start condition		0.6			$\mu\text{s}$
$t_{HD, STA}$	Hold time, start condition to SCL		0.6			$\mu\text{s}$
$t_{ST, STO}$	Setup time, SCL to stop condition		0.6			$\mu\text{s}$
$t_{(BUF)}$	Bus free time between stop and start condition.		1.3			$\mu\text{s}$
$t_{PLH1}$	Propagation delay time, low-to-high-level output	Source-to-sink: 100-kbps pattern; $C_b(\text{Sink}) = 400\text{-pF}^{(1)}$ ; See <a href="#">17</a>		360		ns
$t_{PHL1}$	Propagation delay time, high-to-low-level output			230		ns
$t_{PLH2}$	Propagation delay time, low-to-high-level output	Sink to Source: 100-kbps pattern; $C_b(\text{Source}) = 100\text{-pF}^{(1)}$ ; See <a href="#">18</a>		250		ns
$t_{PHL2}$	Propagation delay time, high-to-low-level output			200		ns

(1)  $C_b$  = total capacitance of one bus line in pF.

### 7.13 Typical Characteristics



图 1. Current vs Data Rate in Retimer Mode

图 2. Current vs Data Rate in Redriver Mode

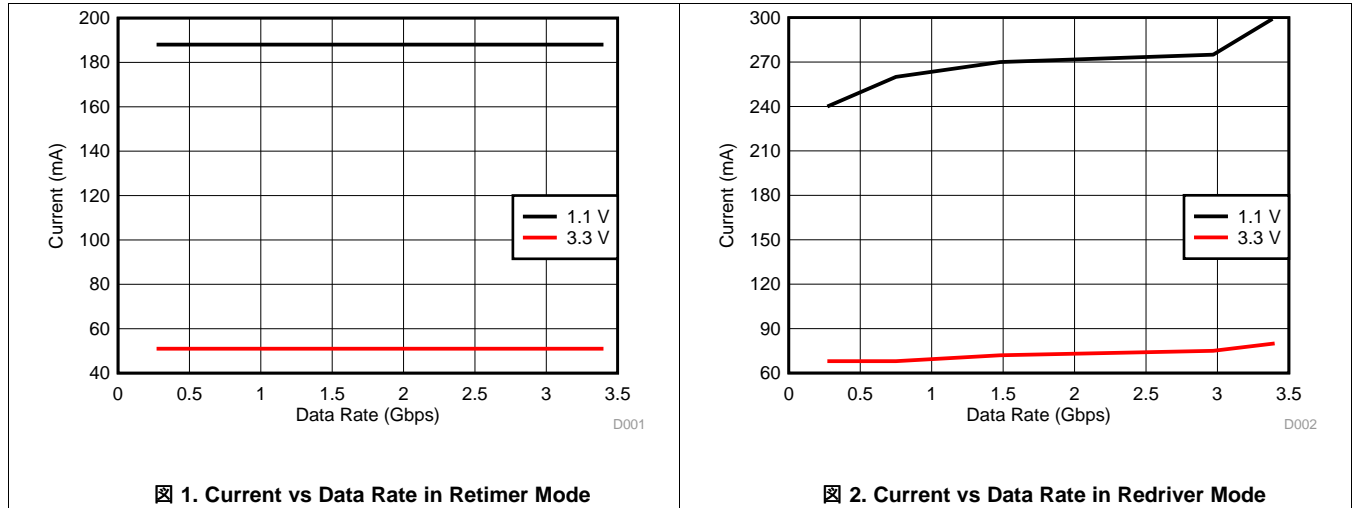

图 3. V<sub>OD</sub> vs V<sub>sadj</sub>

## 8 Parameter Measurement Information

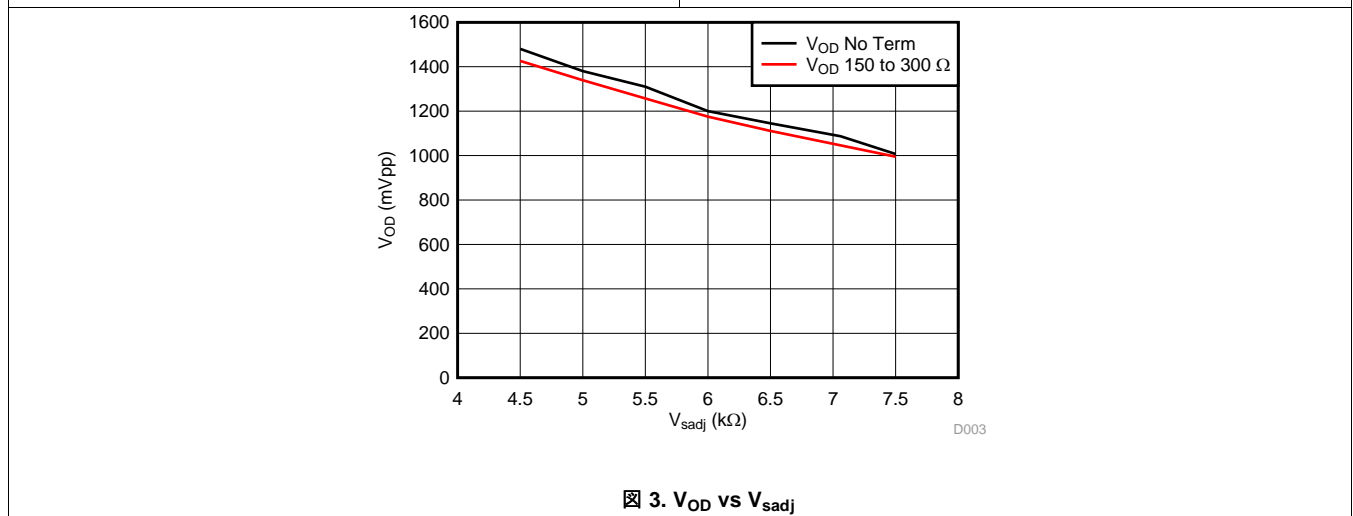

图 4. TMD5 Main Link Test Circuit

Parameter Measurement Information (continued)



图 5. Input and Output Timing Measurements

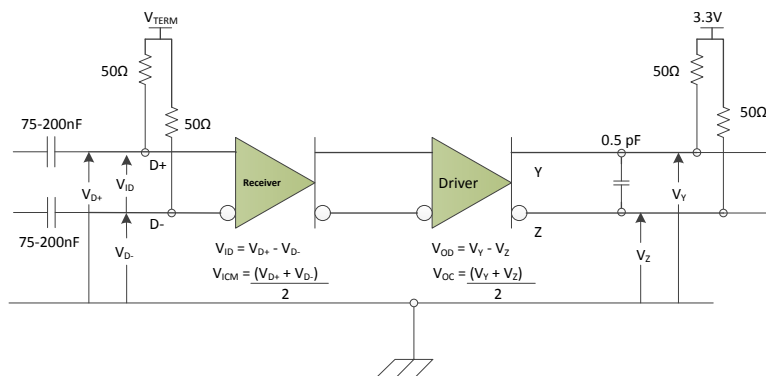

图 6. HDMI and DVI Sink TMDS Output Skew Measurements

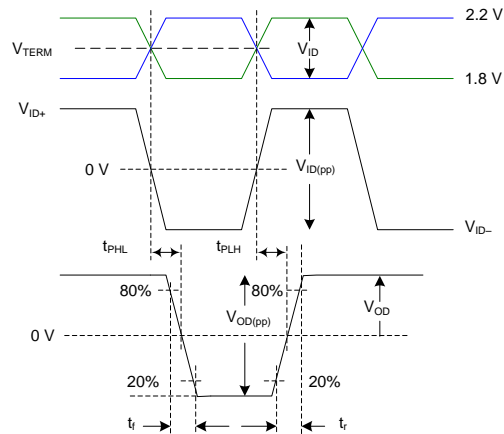

图 7. TMDS Main Link Common Mode Measurements

**Parameter Measurement Information (continued)**

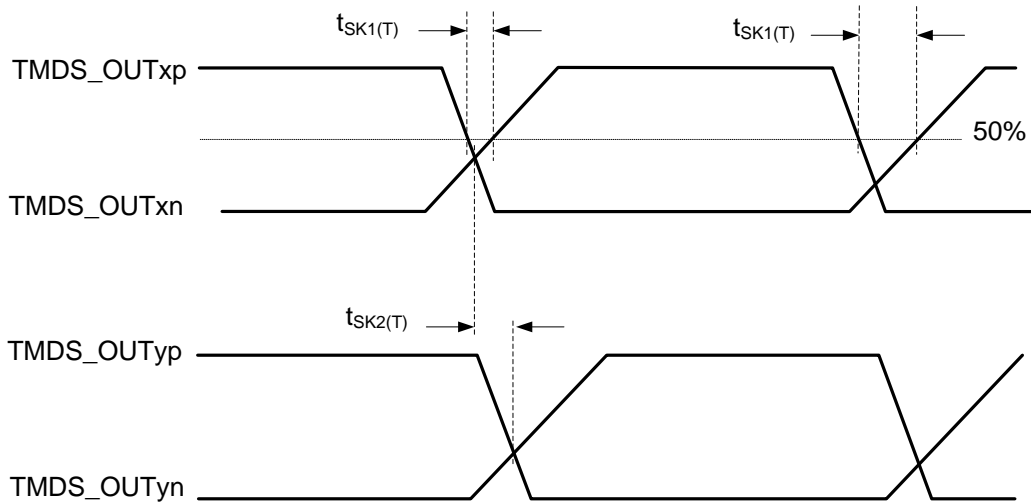

⊗ 8. Output Differential Waveform 0 dB De-Emphasis

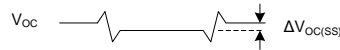
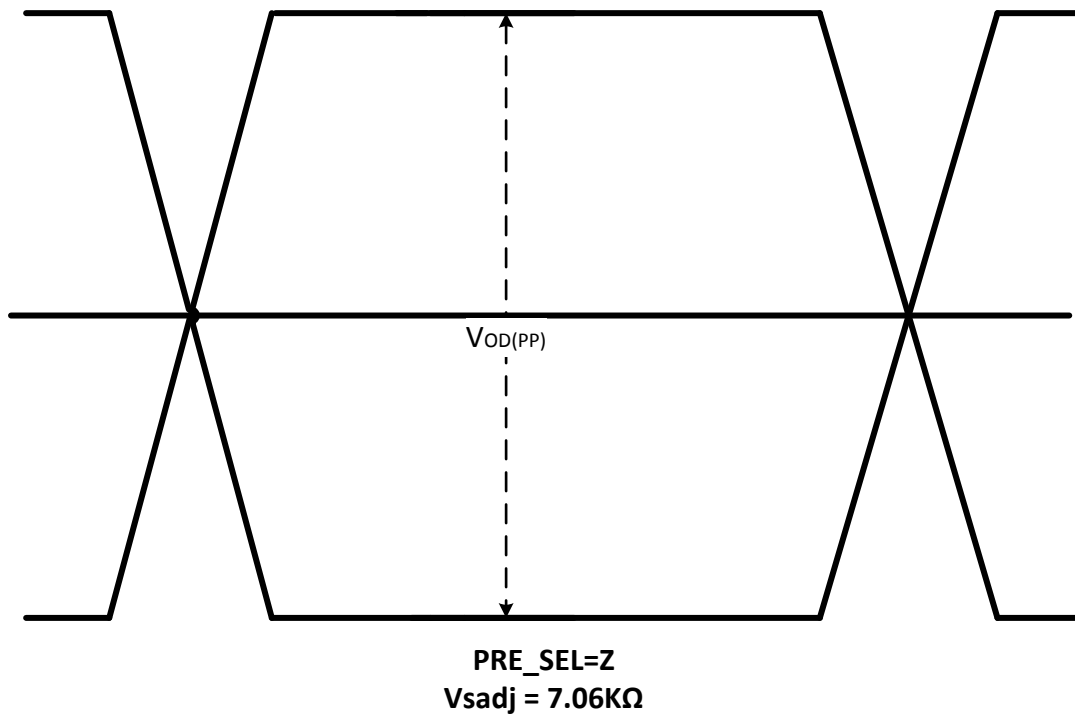
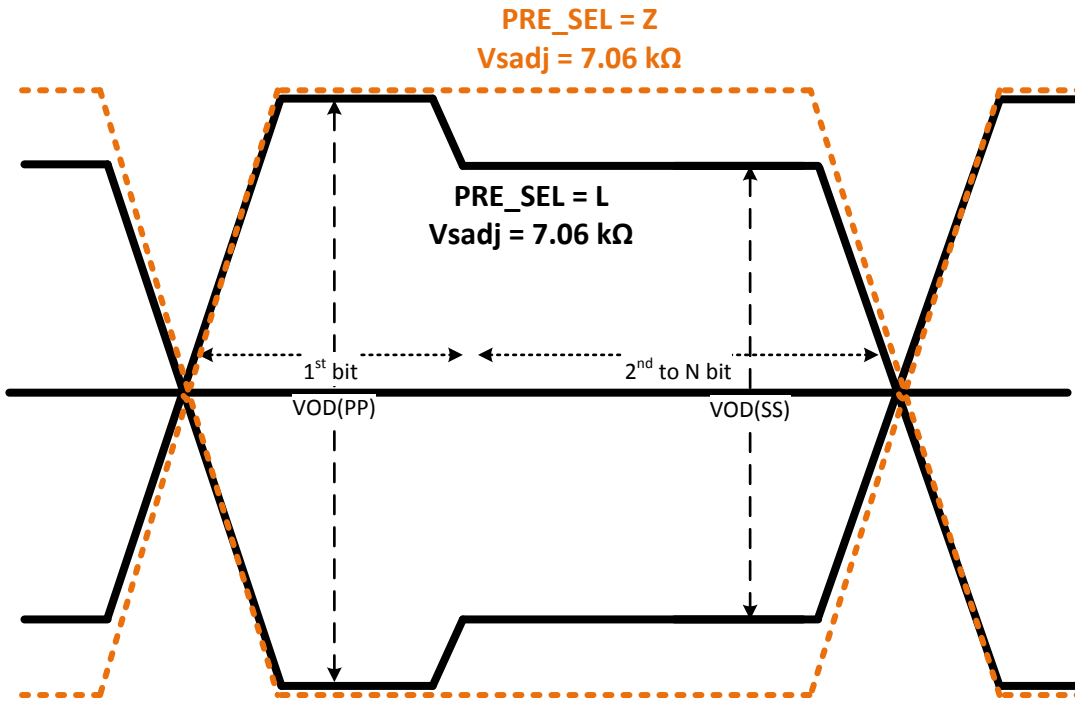

⊗ 9. PRE\_SEL = L for -2dB De-Emphasis

Parameter Measurement Information (continued)

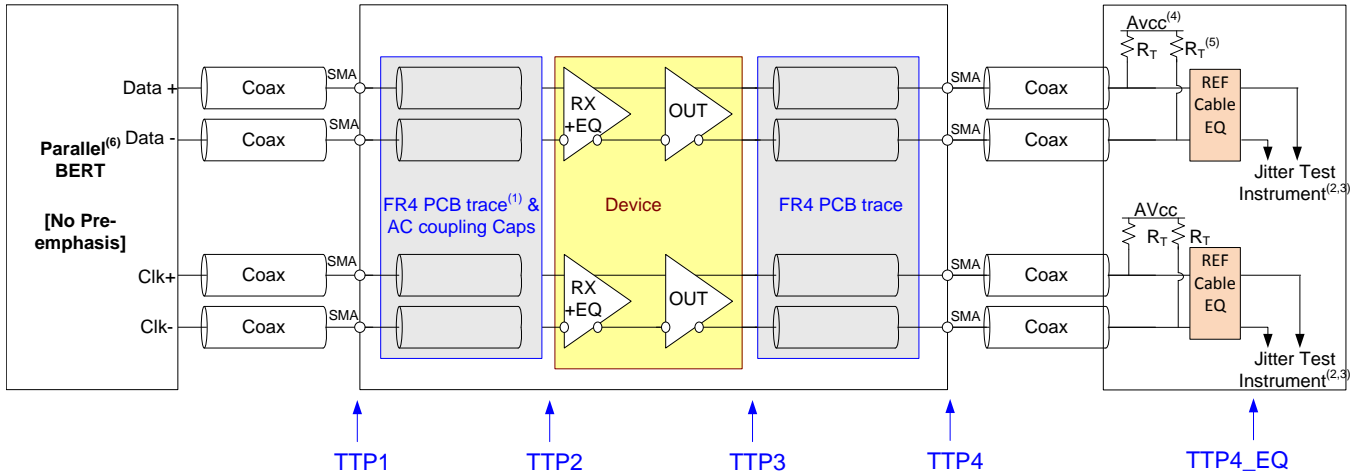

- (1) The FR4 trace between TTP1 and TTP2 is designed to emulate 1-8" of FR4, AC coupling cap, connector and another 1-2" of FR4. Trace width – 4 mils. 100-Ω differential impedance.
- (2) All jitter is measured at a BER of 10<sup>-9</sup>.
- (3) Residual jitter reflects the total jitter measured at TTP4 minus the jitter measured at TTP1.
- (4) AVCC = 3.3-V
- (5) RT = 50-Ω
- (6) The input signal from parallel bit error rate tester (BERT) does not have any pre-emphasis. Refer to [Recommended Operating Conditions](#).

10. TMD5 Output Jitter Measurement

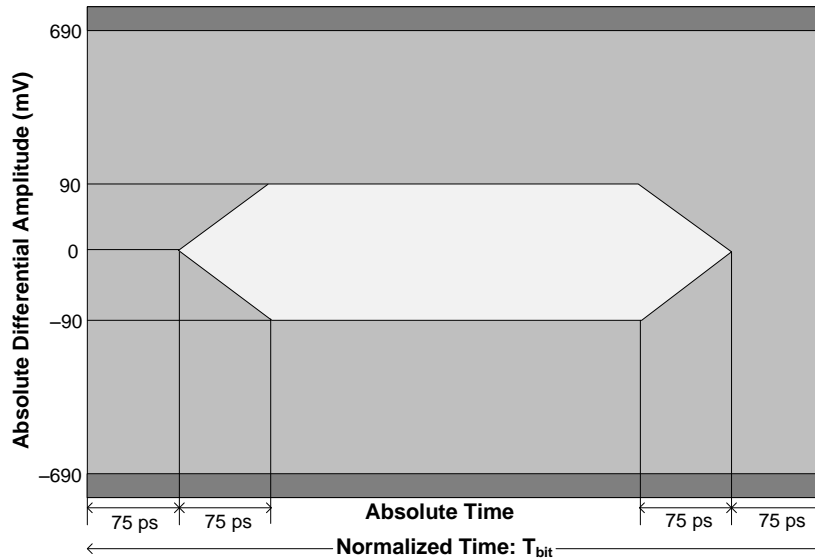

TMD5 data eye mask at connector for clock frequency over 165 MHz.

11. Input Eye Mask at TTP2

**Parameter Measurement Information (continued)**

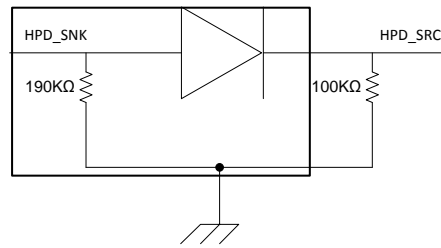

**FIG 12. HPD Test Circuit**

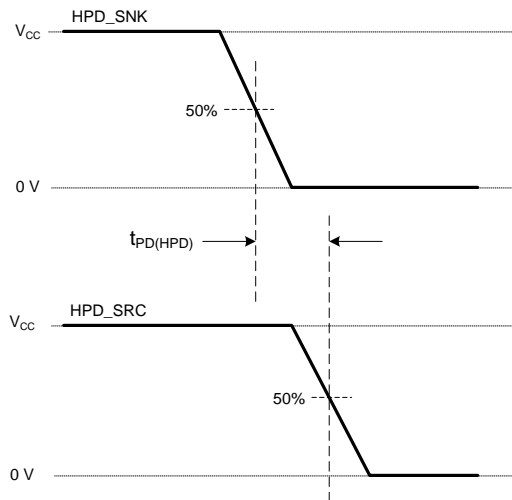

**FIG 13. HPD Timing Diagram Number 1**

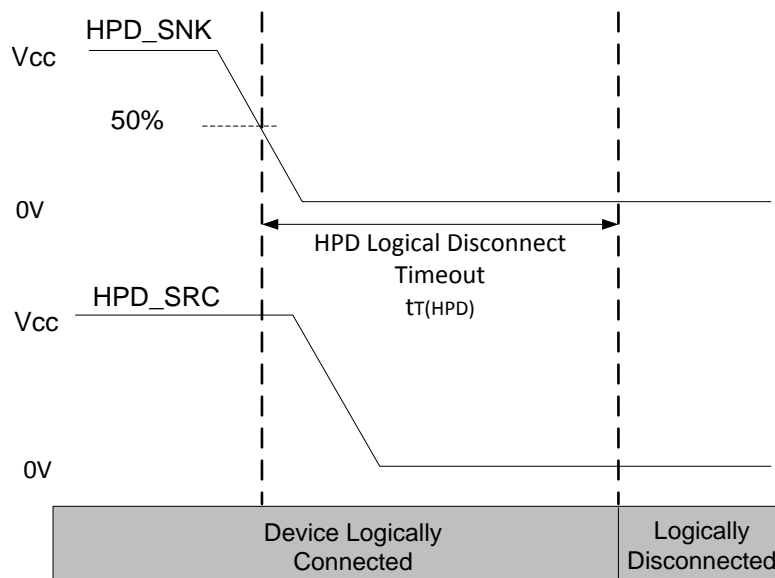

**FIG 14. HPD Logic Disconnect Timeout**

Parameter Measurement Information (continued)

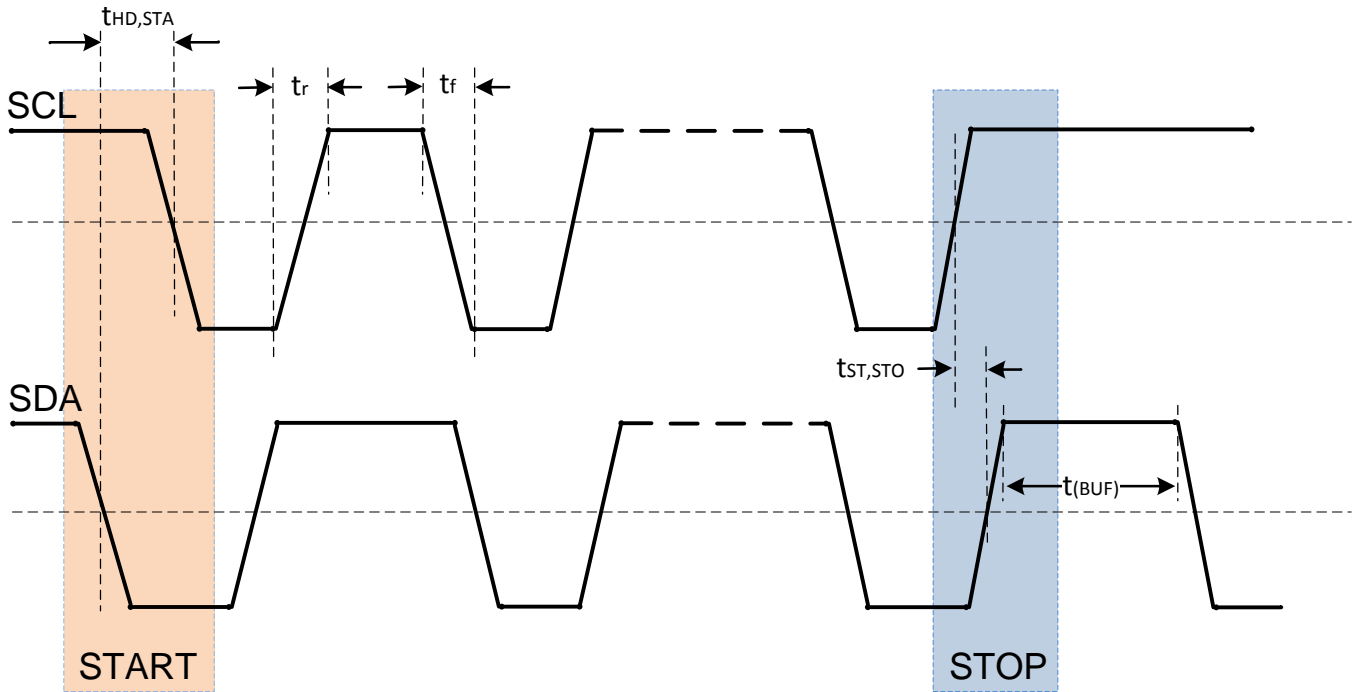

Figure 15. Start and Stop Condition Timing

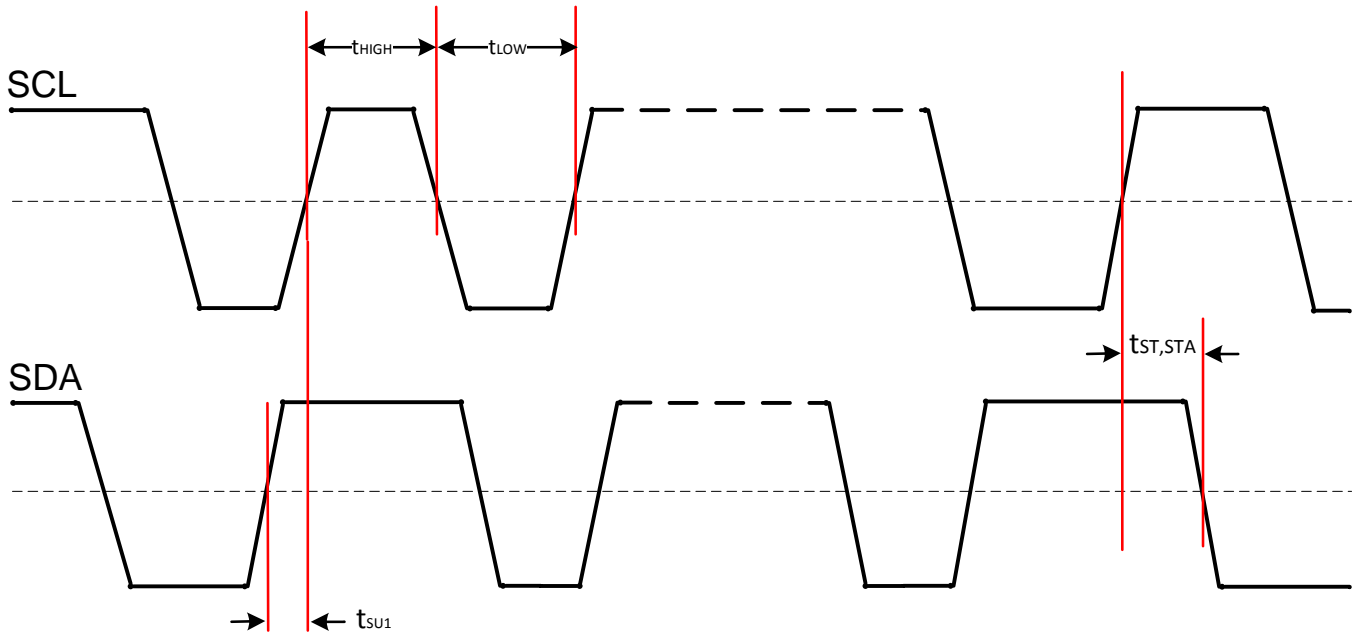
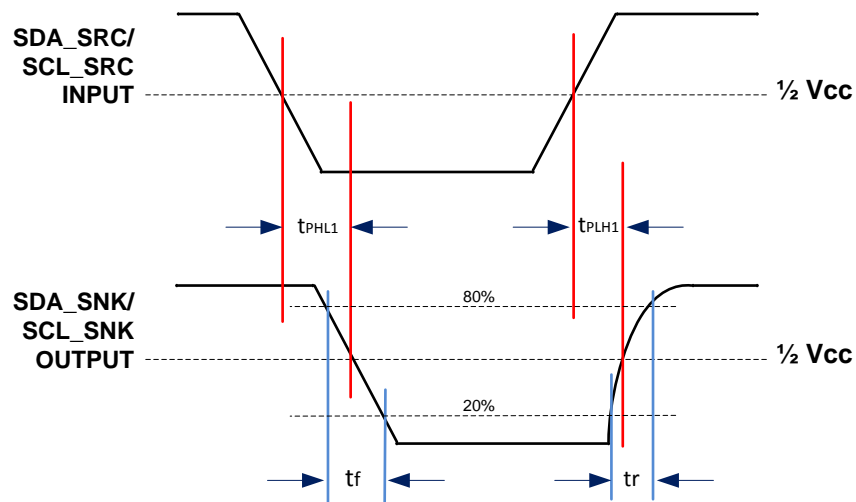
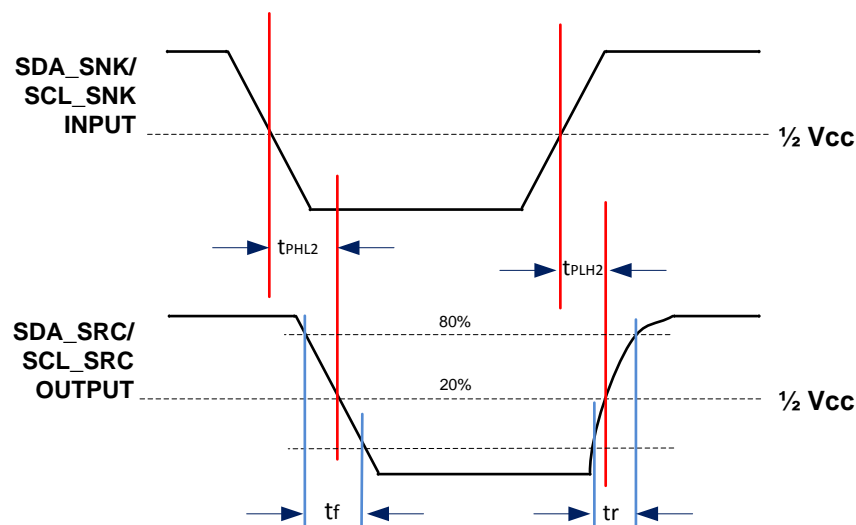

Figure 16. SCL and SDA Timing

**Parameter Measurement Information (continued)**

**☒ 17. DDC Propagation Delay – Source to Sink**

**☒ 18. DDC Propagation Delay – Sink to Source**

## 9 Detailed Description

### 9.1 Overview

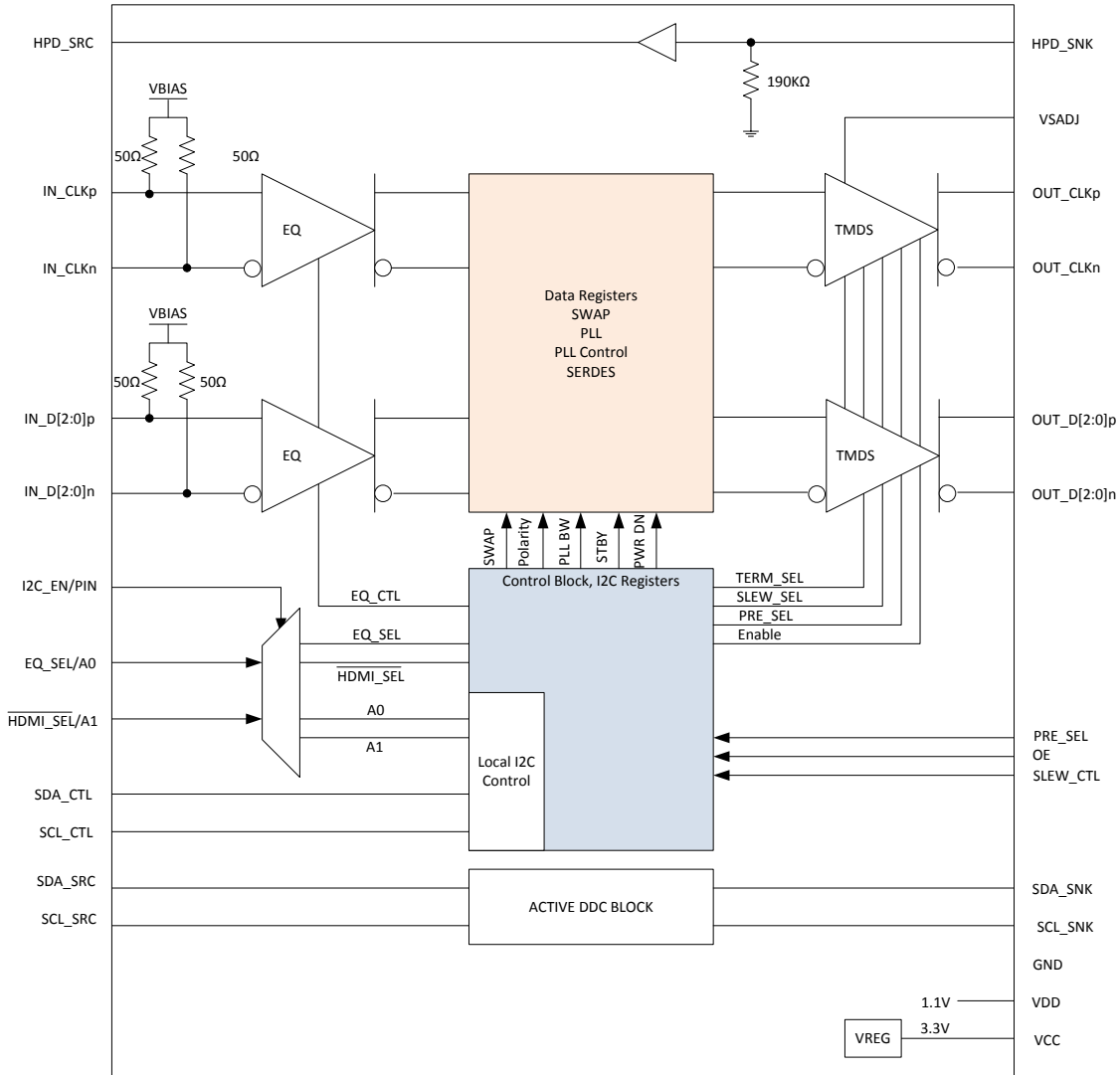
The SNx5DP149 device is a Dual Mode<sup>[1]</sup> DisplayPort retiming level shifter that supports data rates up to 3.4-Gbps for HDMI1.4b. The device takes in AC coupled HDMI/DVI signals and level shifts them to TMDS signals while compensating for loss and jitter through its receiver equalizer and retiming functions. The SNx5DP149 in default configuration should meet most system needs but also provides features that allow the system implementer flexibility in design. Programming can be accomplished through I<sup>2</sup>C<sup>[4]</sup> or pin strapping.

### 9.2 Functional Block Diagram



Copyright © 2016, Texas Instruments Incorporated

## 9.3 Feature Description

### 9.3.1 Reset Implementation

When OE is de-asserted, control signal inputs are ignored; the Dual Mode<sup>[1]</sup> DisplayPort inputs and outputs are high impedance. It is critical to transition the OE input from a low level to a high level after the  $V_{CC}$  supply has reached the minimum recommended operating voltage. Achieve this transition by a control signal to the OE input, or by an external capacitor connected between OE and GND. To ensure that the SNx5DP149 device is properly reset, the OE pin must be de-asserted for at least 100- $\mu$ s before being asserted. When OE is toggled in this manner the device is reset. This requires the device to be reprogrammed if it was originally programmed through I<sup>2</sup>C for configuration. When implementing the external capacitor, the size of the external capacitor depends on the power-up ramp of the  $V_{CC}$  supply, where a slower ramp-up results in a larger value external capacitor. Refer to the latest reference schematic for SNx5DP149; consider approximately 200-nF capacitor as a reasonable first estimate for the size of the external capacitor. Both OE implementations are shown in [Figure 19](#) and [Figure 20](#).

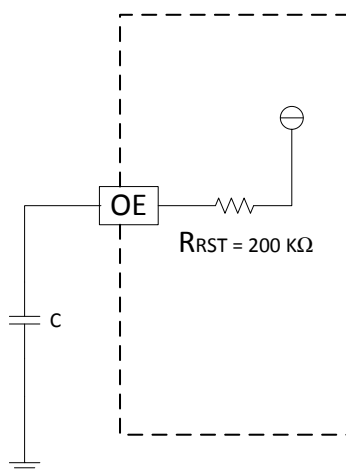

**Figure 19. External Capacitor Controlled OE**

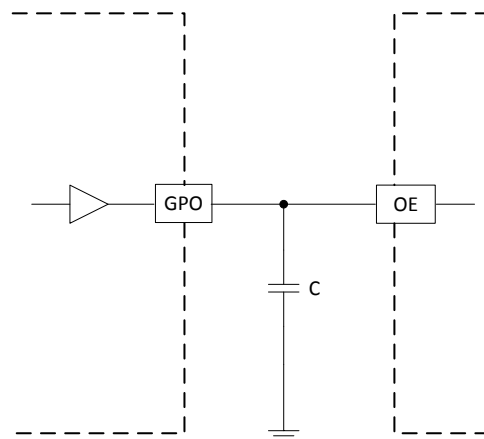

**Figure 20. OE Input from Active Controller**

### 9.3.2 Operation Timing

SNx5DP149 starts to operate after the OE signal goes high (see [Figure 21](#), [Figure 22](#), and [Table 1](#)). Keeping OE low until  $V_{DD}$  and  $V_{CC}$  become stable avoids any timing requirements as shown in [Figure 21](#).

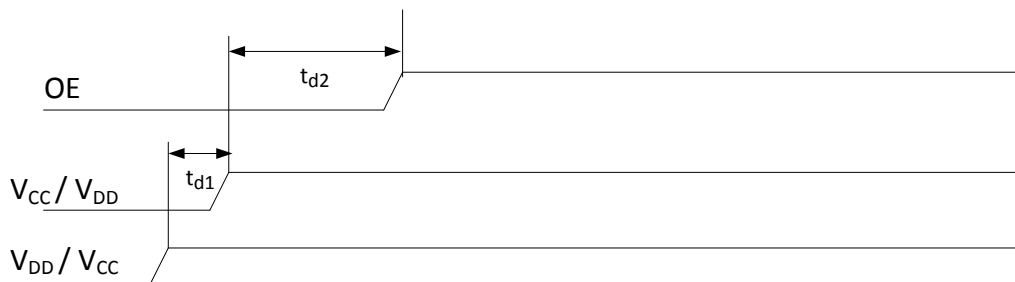

**Figure 21. Power-Up Timing for SSNx5DP149**

Feature Description (continued)

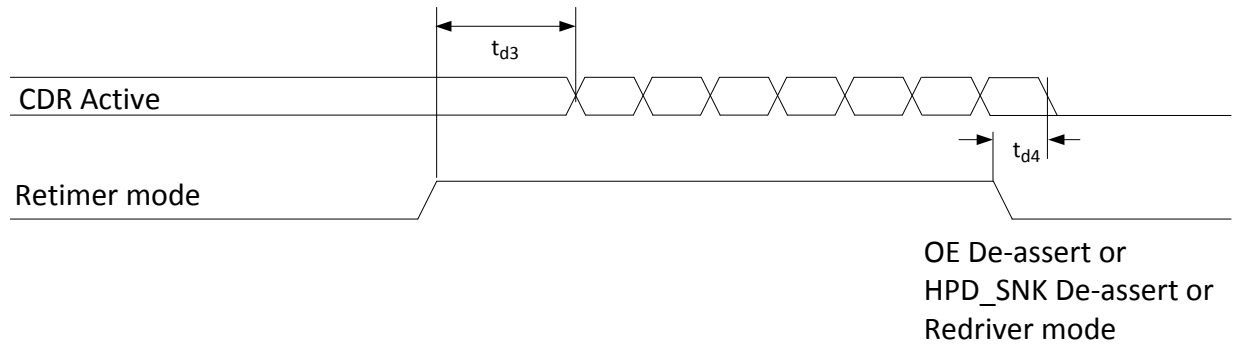

OE De-assert or  
HPD\_SNK De-assert or  
Redriver mode

图 22. CDR Timing for SNx5DP149

表 1. SNx5DP149 Operation Timing

		MIN	MAX	UNIT
$t_{d1}$	$V_{DD}/V_{CC}$ stable before $V_{CC}/V_{DD}$	0	200	$\mu$ s
$t_{d2}$	$V_{DD}$ and $V_{CC}$ stable before OE deassertion	100		$\mu$ s
$t_{d3}$	CDR active operation after retimer mode initial		15	ms
$t_{d4}$	CDR turn off time after retimer mode de-assert		120	ns
VDD_ramp	$V_{DD}$ supply ramp-up requirements		100	ms
VCC_ramp	$V_{CC}$ supply ramp-up requirements		100	ms

9.3.3 Input Lane Swap and Polarity Working

The SNx5DP149 device incorporates the swap function, which can set the input lanes in swap mode. The IN\_D2 routes to the OUT\_CLK position. The IN\_D1 swaps with IN\_D0. The swap function only changes the input pins; EQ setup follows new mapping. The user needs to control the register 0x09h bit 7 for SWAP enable. Lane swap is operational in both redriver and retimer mode.

表 2. Lane Swap<sup>(1)</sup>

NORMAL OPERATION	SWAP = L OR CSR 0x09h BIT 7 IS 1'b1
IN_D2 → OUT_D2	IN_D2 → OUT_CLK
IN_D1 → OUT_D1	IN_D1 → OUT_D0
IN_D0 → OUT_D0	IN_D2 → OUT_D1
IN_CLK → OUT_CLK	IN_CLK → OUT_D2

(1) The output lanes never change. Only the input lanes change. See and 图 23.

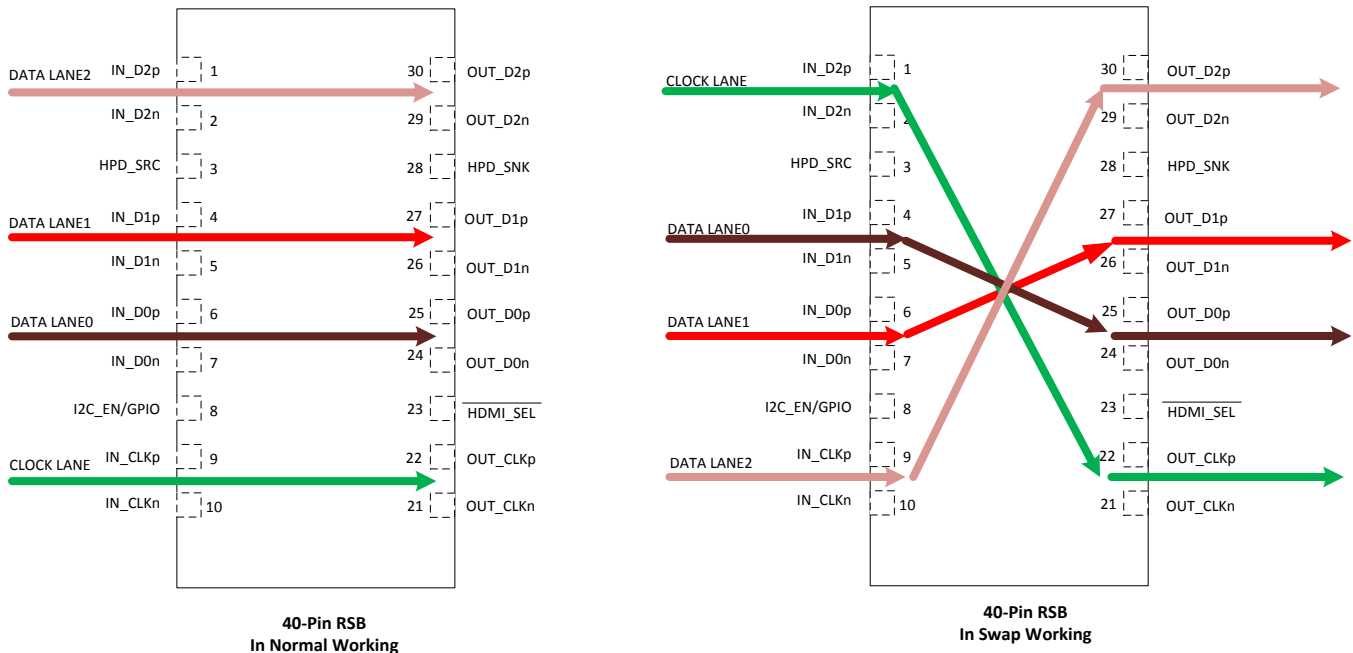

**图 23. SNx5DP149 Swap Function for 40 Pins**

The SNx5DP149 can also change the polarity of the input signals. Use Register 0x9h bit 6 to swap polarity using I<sup>2</sup>C. Polarity swap only works for retimer mode. When the device is in automatic redriver to retimer mode this only works when device is in retimer stage. If set and data rate falls below 1.0-Gbps in this mode the polarity function will be lost.

### 9.3.4 Main Link Inputs

Standard Dual Mode[1] DisplayPort terminations are integrated on all inputs with expected AC coupling capacitors on board prior to input pins. External terminations are not required. Each input data channel contains an adaptive or fixed equalizer to compensate for cable or board losses. The voltage at the input pins must be limited below the absolute maximum ratings. The input pins have incorporated failsafe circuits. The input pins can be polarity changed through the local I<sup>2</sup>C register.

### 9.3.5 Main Link Inputs Debug Tools

There are two methods for debugging a system making sure the inputs to the SNx5DP149 are valid. A TMDS error checker is implemented that will increment an error counter per data lane. This allows the system implementer to determine how the link between the source and SNx5DP149 is performing on all three data lanes. See CSR Bit Field Definitions – RX PATTERN VERIFIER CONTROL/STATUS register in 表 10.

If a high error count is evident, the SNx5DP149 has the ability to provide the general eye quality. A tool is available that uses the I<sup>2</sup>C[4] link to download data that can be plotted for an eye diagram. This is available per data lane.

### 9.3.6 Receiver Equalizer

Equalizers are used to clean up inter-symbol interference (ISI) jitter or loss from the bandwidth-limited board traces or cables. The SNx5DP149 device supports both fixed receiver equalizer (redriver and retimer mode) and adaptive receive equalizer (retimer mode) by setting the EQ\_SEL/A0 pin or through I<sup>2</sup>C using reg0Ah[5]. When the EQ\_SEL/A0 pin is high, the EQ gain is fixed to 14-dB. The EQ gain will be 7.5-dB if the EQ\_SEL/A0 pin is set low. The SNx5DP149 device operates in adaptive equalizer mode when EQ\_SEL/A0 left floating. Using adaptive equalization the gain will be automatically adjusted based on the data rate to compensate for variable trace or cable loss. Using the local I<sup>2</sup>C[4] control, reg0Dh[5:1], the fixed EQ gain can be selected for both data and clock.

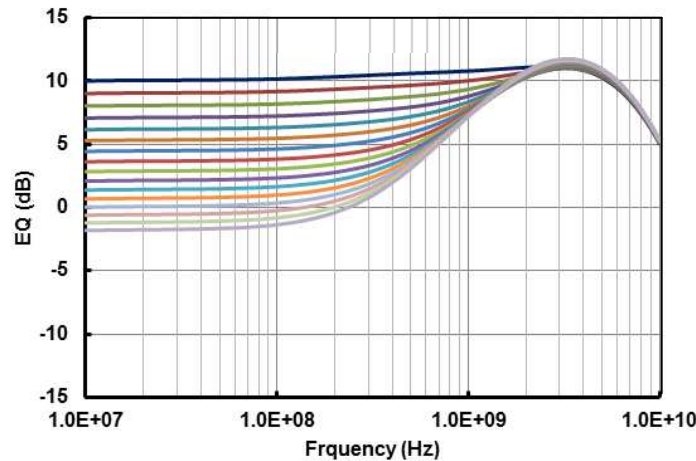

Figure 24. Adaptive EQ Gain Curve

### 9.3.7 Termination Impedance Control

For HDMI1.4b[2] when data rate over 2 Gbps, the output performance could be better if the termination value between 150 to 300-Ω which was allowed. For compliance this may not be the best solution so be prepared to utilize no termination. The SNx5DP149 supports two different source termination impedances for HDMI1.4b[2]. This can be adjusted by I<sup>2</sup>C[4]; reg0Bh[4:3] TX\_TERM\_CTL.

### 9.3.8 TMDS Outputs

An 1% precision resistor, 6.5-kΩ, is recommended to be connected from V<sub>sdj</sub> pin to ground to allow the differential output swing to comply with TMDS signal levels. The differential output driver provides a typical 10-mA current sink capability when no source term is enabled, which provides a typical 500-mV voltage drop across a 50-Ω termination resistor. As compliance testing is system dependant this resistor value can be adjusted.

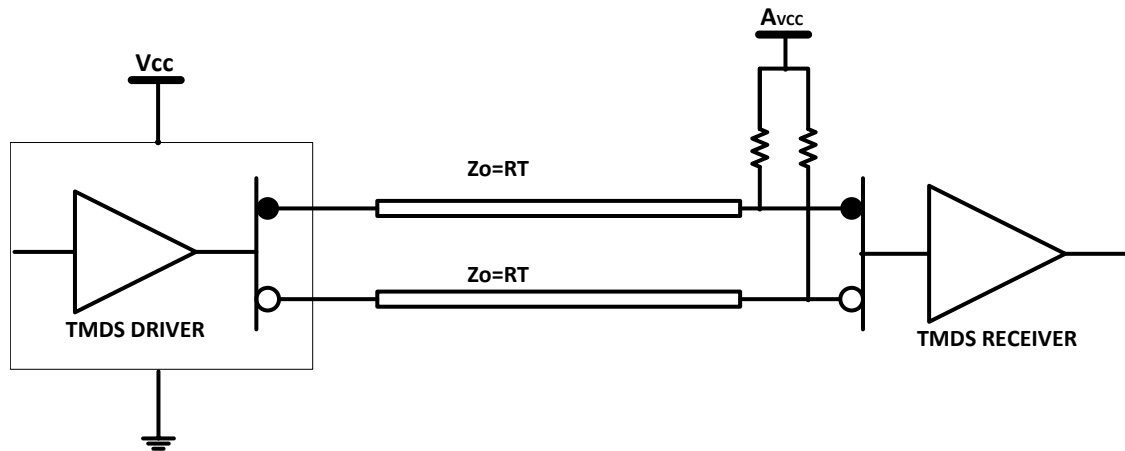

Figure 25. TMDS Driver and Termination Circuit

Referring to Figure 25, if both V<sub>CC</sub> (device supply) and AVCC (sink termination supply) are powered, the TMDS output signals are high impedance when OE = low. The normal operating condition is that both supplies are active. A total of 33-mW of power is consumed by the terminations independent of the OE logical selection. When AVCC is powered on, normal operation (OE controls output impedance) is resumed. When the power source of the device is off and the power source to termination is on, the IO(off) (output leakage current) specification ensures the leakage current is limited 45-μA or less.

The clock and data lanes V<sub>OD</sub> can be changed through I<sup>2</sup>C[4] (see VSWING\_CLK and VSWING\_DATA in Table 8 for details). shows the different output voltage based on different V<sub>sdj</sub> resistor values.

### 9.3.8.1 Pre-Emphasis/De-Emphasis

The SNx5DP149 provides De-emphasis as a way to compensate for the ISI loss between the TMDS outputs and the receiver it is driving. There are two methods to implement this function. When in pin strapping mode the PRE\_SEL pin controls this. The PRE\_SEL pin provides –2-dB, or 0-dB de-emphasis, which allows output signal pre-conditioning to offset interconnect losses from the SNx5DP149 device outputs to a TMDS receiver. TI recommends setting PRE\_SEL at 0 dB while connecting to a receiver through a short PCB route. When pulled to ground with a 65-k $\Omega$  resistor –2-dB can be realized, see [Figure 9](#). When using I<sup>2</sup>C, Reg0Ch[1:0] is used to make these adjustments.

As there are times true pre-emphasis may be the best solution there are two ways to accomplish this. If pin strapping is being use the best method is to reduce the Vsadj resistor value increasing the V<sub>OD</sub> and then pulling the PRE\_SEL pin to ground using the 65-k $\Omega$  resistor, see [Figure 26](#). If using I<sup>2</sup>C this can be accomplished using two methods. First is similar to pin strapping by adjusting the Vsadj resistor value and then implementing –2-dB de-emphasis. Second method is to set Reg0Ch[7:5] = 011 and the set Reg0Ch[1:0] = 01 which accomplishes the same pre-emphasis setting. See [Figure 27](#).

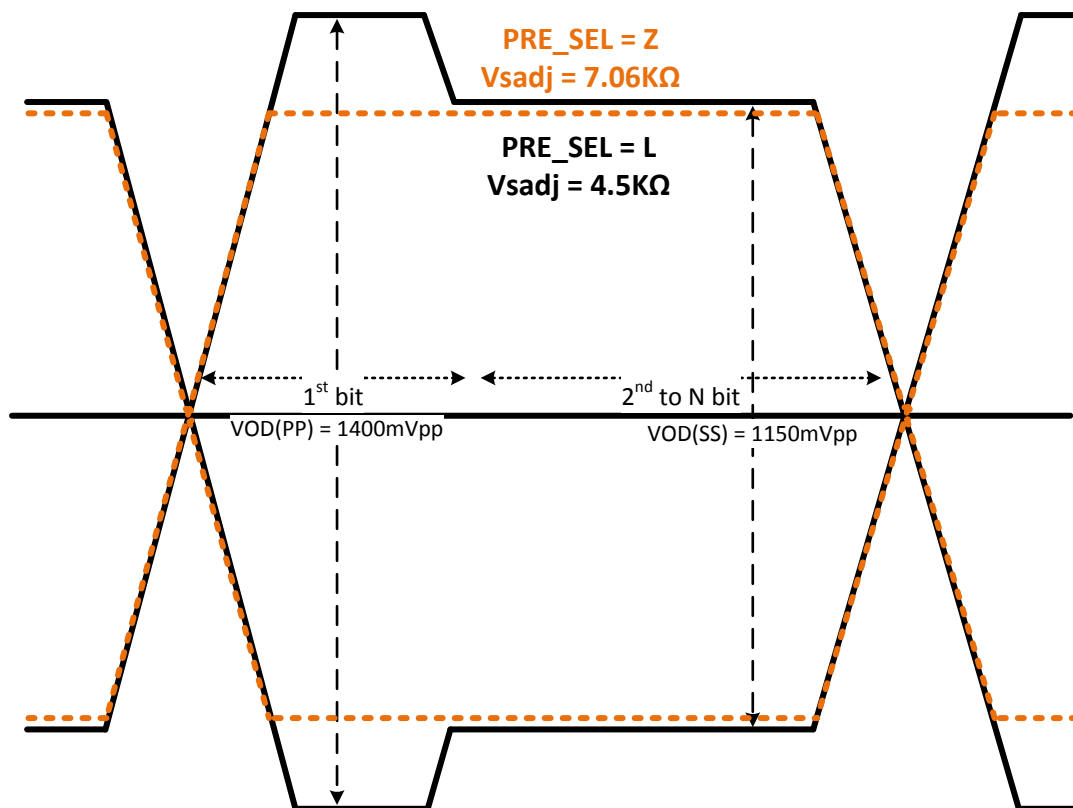

**Figure 26. Pre-Emphasis Using Pin Strapping Method**



图 27. Pre-Emphasis Using I<sup>2</sup>C Method

## 9.4 Device Functional Modes

### 9.4.1 Retimer Mode

Clock and data recovery circuits (CDR) are used to track, sample and retim the equalized data bit streams. The CDRs are designed with loop bandwidth to minimize the amount of jitter transfer from the video source to the TMDS outputs. Input jitter within the CDR's PLL bandwidth, < 1-MHz, will be transferred to the TMDS outputs. Higher frequency jitter above the CDR loop bandwidth is attenuated, providing a jitter cleaning function to reduce the amount of high frequency jitter from the video source. The retimer is automatically activated at pixel clock above approximately 100-MHz when jitter cleaning is needed for robust operation. The retimer operates at about 1.0 to 3.4-Gbps DR supporting HDMI1.4b[3]. At pixel clock frequency below about 100 MHz, the SNx5DP149 automatically bypasses the internal retimer and operates as a redriver. When the video source changes resolution, the internal retimer starts the acquisition process to determine the input clock frequency and acquire lock to the new data bit streams. During the clock frequency detection period and the retimer acquisition period (that last approximately 7-ms), the TMDS drivers can be kept active (default) or programmed to be disabled to avoid sending invalid clock or data to the downstream receiver.

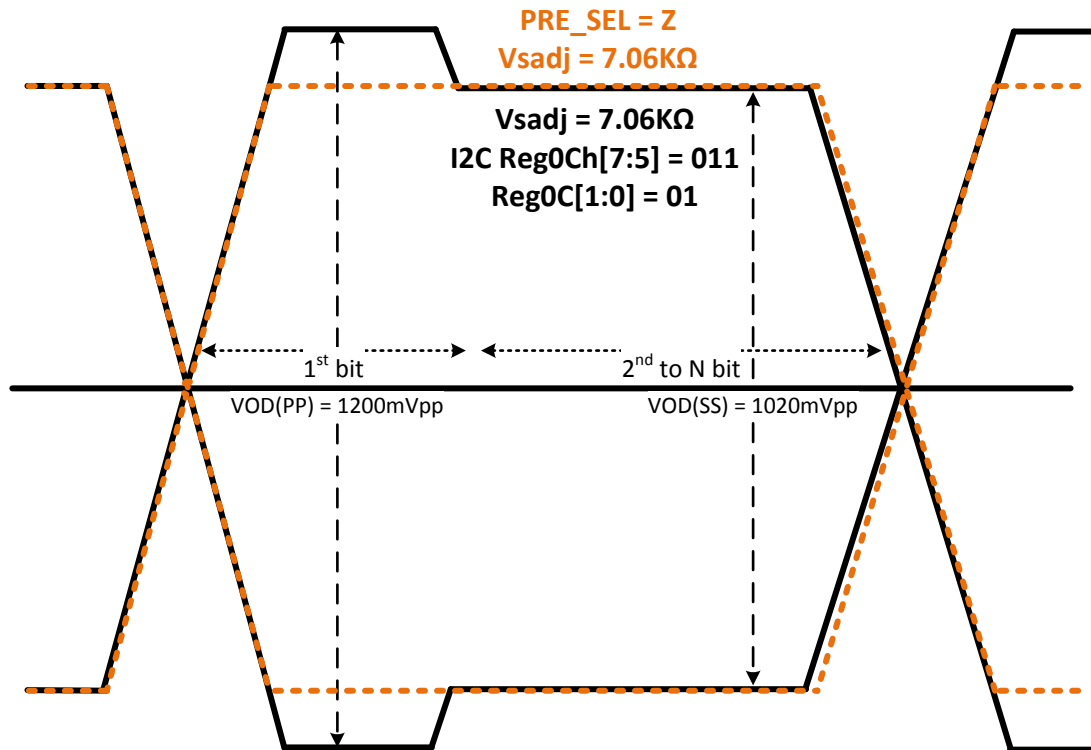
### 9.4.2 Redriver Mode

The SNx5DP149 also has a redriver mode that can be enabled through I<sup>2</sup>C[4]; at offset address 0Ah bits 1:0 DEV\_FUNC\_MODE. When in this mode, the CDR and PLL are shut off, thus reducing power. Jitter performance is degraded as the device will now only compensate for ISI loss in the link. In redriver mode HDMI1.4b[3] compliance is not guaranteed as skew compensation and retiming functions are disabled. Excessive random or phase jitter will not be compensated.

## Device Functional Modes (continued)

### 9.4.3 DDC Functional Description

The SNx5DP149 solves sink- or source-level issues by implementing a master/slave control mode for the DDC bus. When the SNx5DP149 detects the start condition on the DDC bus from the SDA\_SRC/SCL\_SRC, it will transfer the data or clock signal to the SDA\_SNK/SCL\_SNK with little propagation delay. When SDA\_SNK detects the feedback from the downstream device, the SNx5DP149 will pull up or pull down the SDA\_SRC bus and deliver the signal to the source.

The DDC link defaults to 100 kbps, but can be set to various values including 400 kbps by setting the correct value to address 22h (see [表 3](#)) through the I<sup>2</sup>C access on the DDC interface. The DDC lines are 5-V tolerant. The HPD\_SRC goes to high impedance when VCC is under low power conditions, < 1.5-V.

## 9.5 Register Maps

### 9.5.1 DP-HDMI Adaptor ID Buffer

The SNx5DP149 device includes the DP-HDMI adapter ID buffer for HDMI/DVI adaptor recognition, defined by the VESA DisplayPort Dual-Mode Standard Version 1.1, accessible by standard I<sup>2</sup>C[4] protocols through the DDC interface when the `HDMI_SEL/A1` pin is low. The DP-HDMI adapter buffer and extended DDC register for Type 2 capability is accessed at target addresses 80h (Write) and 81h (Read).

The DP-HDMI adapter buffer contains a read-only phrase DP-HDMI ADAPTOR<EOT> converted to ASCII characters, as shown in 表 3, and supports the WRITE command procedures (accessed at target address 80h) to select the subaddress, as recommended in the VESA DisplayPort Interoperability Guideline Adaptor Checklist Version 1.0 section 2.3.

**表 3. SNx5DP149 DP-HDMI Adaptor ID Buffer and Extended DDC**

Address	Description	Value HDMI	Value DVI	Read or Read/Write
00h	HDMI ID code	44h	00h	Read only
01h		50h	00h	
02h		2Dh	00h	
03h		48h	00h	
04h		44h	00h	
05h		4Dh	00h	
06h		49h	00h	
07h		20h	00h	
08h		41h	00h	
09h		44h	00h	
0Ah		41h	00h	
0Bh		50h	00h	
0Ch		54h	00h	
0Dh		4Fh	00h	
0Eh		52h	00h	
0Fh		04h	00h	
10h	Video Adaptor Identifier Bit 2:0 ADAPTOR_REVISION	0	0	Read only
	Bit 3 Reserved: but 0 for type 2	0	0	
	Bits 7:4 1010 = Dual mode defined by dual mode[1] standard	1010	0	
11h	IEE_OUI first two hex digits	08h	08h	Read only
12h	IEE_OUI second two hex digits	00h	00h	Read only
13h	IEE_OUI third two hex digits	28h	28h	Read only
14h	Device ID	44h	44h	Read only
15h		50h	50h	
16h		31h	31h	
17h		34h	34h	
18h		39h	39h	
19h		00h	00h	
1Ah	Hardware revision	02h	02h	Read only
	Bits 7:4 major revision	00h	00h	
	Bits 3:0 minor revision	02h	02h	
1Bh	Firmware or software major revision	00h	00h	Read only
1Ch	Firmware or software minor revision	00h	00h	Read only

**Register Maps (continued)**
**表 3. SNx5DP149 DP-HDMI Adaptor ID Buffer and Extended DDC (continued)**

Address	Description	Value HDMI	Value DVI	Read or Read/Write
1Dh	Max TMDS clock rate Default value is 88h in HDMI column Note: Value determined by taking clock rate and dividing by 2.5 and converting to HEX. For HDMI2.0 extend as if the clock rate extended instead of its actual method, clock 1/10 DR and not 1/40 DR.	88h	42h	Read only
1Eh	If I2C_DR_CTL = 0 the value is 0Fh → If DDC_AUX_DR_SEL = 0 the value is 0Fh If I2C_DR_CTL = 1 the value is 1Fh → If DDC_AUX_DR_SEL = 1 then value is 1Fh If I2C_DR_CTL = 0 the value is 0Fh If I2C_DR_CTL = 1 the value is 1Fh	0Fh	0Fh	Read only
1Fh	Reserved	00h	00h	Write/Read
20h	<u>TMDS_OE</u> Bit 0: 0 = TMDS_ENABLED (default) 1 = TMDS_DISABLED Bits 7:1 Reserved	00h	00h	Write/Read
21h	HDMI Pin Control Bit 0 = CEC_EN Enables connection between the HDMI CEC pin connected to the sink and the CONFIG2 pin to the upstream device + 27-kΩ pullup. 0 = CEC_DISABLED (default) 1 = CEC_ENABLED Bits 7:1 = RESERVED	00h	00h	Write/Read
22h	Writing a bit pattern to this register that is not defined above may result in an unpredictable I <sup>2</sup> C speed selection, but the adaptor must continue to otherwise work normally. Only applicable when using I <sup>2</sup> C-over-AUX transport 01h = 1-Kbps 02h = 5-Kbps 04h = 10-Kbps 08h = 100-kbps 10h = 400-Kbps (RSVD in Dual Mode STND) On read, the dual-mode cable adaptor returns a value to indicate the speed currently in use. The default I2C speed prior to software writing to this register is 100-Kbps. Illegal write value shall write register default (08h). This register sets the DDC output DR whether I <sup>2</sup> C-over-AUX or straight DDC	08h	08h	Write/Read
23h-FFh	Reserved	00h	00h	Read

**9.5.2 Local I<sup>2</sup>C Interface Overview**

The SCL\_CTL and SDA\_CTL pins are used for I<sup>2</sup>C clock and I<sup>2</sup>C data respectively. The SNx5DP149 I<sup>2</sup>C interface conforms to the 2-wire serial interface defined by the I<sup>2</sup>C Bus Specification, Version 2.1 (January 2000), and supports the fast mode transfer up to 400 kbps.

The device address byte is the first byte received following the start condition from the master device. The 7-bit device address for the SNx5DP149 device decides by the combination of EQ\_SEL/A0 and HDMI\_SEL/A1. 表 4 clarifies the SNx5DP149 device target address.

**表 4. I<sup>2</sup>C Device Address Description**

A1/A0	SNx5DP149 I <sup>2</sup> C Device Address								ADD
	7 (MSB)	6	5	4	3	2	1	0 (W/R)	
00	1	0	1	1	1	1	0	0/1	BC/BD
01	1	0	1	1	1	0	1	0/1	BA/BB
10	1	0	1	1	1	0	0	0/1	B8/B9
11	1	0	1	1	0	1	1	0/1	B6/B7

### 9.5.3 I<sup>2</sup>C Control Behavior

Follow this procedure to write to the SNx5DP149 device I<sup>2</sup>C registers:

1. The master initiates a write operation by generating a start condition (S), followed by the SNx5DP149 device 7-bit address and a zero-value W/R bit to indicate a write cycle.
2. The SNx5DP149 device acknowledges the address cycle by combination of A0 and A1.
3. The master presents the subaddress (I<sup>2</sup>C register within SNx5DP149 device) to be written, consisting of one byte of data, MSB-first.
4. The SNx5DP149 device acknowledges the subaddress cycle.
5. The master presents the first byte of data to be written to the I<sup>2</sup>C register.
6. The SNx5DP149 device acknowledges the byte transfer.
7. The master may continue presenting additional bytes of data to be written, with each byte transfer completing with an acknowledge from the SNx5DP149 .
8. The master terminates the write operation by generating a stop condition (P).

Follow this procedure to read the SNx5DP149 I<sup>2</sup>C registers:

1. The master initiates a write operation by generating a start condition (S), followed by the SNx5DP149 7-bit address and a zero-value W/R bit to indicate a write cycle.
2. The SNx5DP149 device acknowledges the address cycle by combination of A0 and A1.
3. The master presents the subaddress (I<sup>2</sup>C register within SNx5DP149 device) to be read, consisting of one byte of data, MSB-first.
4. The SNx5DP149 device acknowledges the subaddress cycle.
5. The master initiates a read operation by generating a start condition (S), followed by the SNx5DP149 7-bit address and a one-value W/R bit to indicate a read cycle.
6. The SNx5DP149 device acknowledges the address cycle.
7. The SNx5DP149 device transmits the contents of the memory registers MSB-first starting at the written subaddress.
8. The SNx5DP149 device will wait for either an acknowledge (ACK) or a not-acknowledge (NACK) from the master after each byte transfer; the I<sup>2</sup>C master acknowledges reception of each data byte transfer.
9. If an ACK is received, the SNx5DP149 device transmits the next byte of data.
10. The master terminates the read operation by generating a stop condition (P).

#### 注

No sub-addressing is included for the read procedure, and reads start at register offset 00h and continue byte by byte through the registers until the I<sup>2</sup>C master terminates the read operation.

Refer to [表 6](#) for the SNx5DP149 device local I<sup>2</sup>C register descriptions. Reads from reserved fields return 0s and writes are ignored.

## 9.5.4 I<sup>2</sup>C Control and Status Registers

Reads from reserved fields return 0, and writes to read-only reserved registers are ignored. Writes to reserved registers, which are marked with 'W', produce unexpected behavior. All addresses not defined by this specification are considered reserved. Reads from these addresses return 0 and writes will be ignored.

### 9.5.4.1 Bit Access Tag Conventions

A table of bit descriptions is typically included for each register description that indicates the bit field name, field description, and the field access tags. The field access tags are described in [表 5](#).

**表 5. Field Access Tags**

ACCESS TAG	NAME	DESCRIPTION
R	Read	The field is read by software
W	Write	The field is written by software
S	Set	The field is set by a write of one. Writes of 0 to the field have no effect
C	Clear	The field is cleared by a write of 1. Writes of 0 to the field have no effect
U	Update	Hardware may autonomously update this field
NA	No access	Not accessible or not applicable

### 9.5.4.2 CSR Bit Field Definitions

#### 9.5.4.2.1 ID Registers

**表 6. ID Registers**

ADDRESS	BIT	DESCRIPTION	ACCESS
00h:07h	7:0	DEVICE_ID These fields return a string of ASCII characters "DP149" followed by three space characters. Address 0x00 – 0x07 = {0x44"D", 0x50"P", 0x31"1", 0x34"4", 0x39"9", 0x20, 0x20, 0x20}	R
08h	7:0	REV_ID. This field identifies the device revision. 0000001 – DP149HPA159 revision 1	R

**9.5.4.2.2 Misc Control**
**表 7. Misc Control**

ADDRESS	BIT	DEFAULT	DESCRIPTION	ACCESS
09h	7	1'b0	SWAP_EN: This field enables swapping the input main link lanes <b>0 – Disable (default)</b> 1 – Enable Note: field is loaded from SWAP/POL pin; Writes ignored when I2C_EN/PIN = 0	RWU
	6	1'b0	LANE_POLARITY: swaps the input data and clock lanes polarity. <b>0 – Disabled: No polarity swap</b> 1 – Swaps the input data and clock lane polarity Note: field is loaded from SWAP/POL pin; Writes ignored when I2C_EN/PIN = 0. This feature is only valid when in retimer mode.	RWU
	5:4	2'b00	Reserved	R
	3	1'b0	PD_EN <b>0 – Normal working (default)</b> 1 – Forced power-down by I <sup>2</sup> C, lowest power state	RW
	2	1'b0	HPD_AUTO_PWRDWN_DISABLE <b>0 – Automatically enters power down mode based on HPD_SNK (default)</b> 1 – Will not automatically enter power mode based upon HPD_SNK	RW
	1:0	2'b10	I2C_DR_CTL. I2C data rate supported for configuring device 00 – 5-kbps 01 – 10-kbps <b>10 – 100-kbps (default)</b> 11 – 400-kbps (Note: HPD_AUTO_PWRDWN_DISABLE must be set before enabling 400 Kbps mode)	RW
0Ah	7	1'b0	Application Mode Selection <b>0 – Source (default) - Set the adaptive EQ mid point to between 6.5-dB and 7.5-dB</b> 1 – Sink - Sets the adaptive EQ starting point to between 12-dB and 13-dB	RW
	6	1'b0	HPDSNK_GATE_EN: This field sets the functional relationship between HPD_SNK and HPD_SRC. <b>0 – HPD_SNK passed through to the HPD_SRC (default)</b> 1 – HPD_SNK will not pass through to the HPD_SRC.	RW
	5	1'b1	EQ_ADA_EN: this field enables the equalizer working state. 0 – Fixed EQ <b>1 – Adaptive EQ (default)</b> Writes are ignored when I2C_EN/PIN = 0	RWU
	4	1'b1	EQ_EN: this field enables the receiver equalizer. 0 – EQ disabled <b>1 – EQ enable (default)</b>	RW
	3	1'b0	Reserved	RW
	2	1'b0	APPLY_RXTX_CHANGES, Self clearing write-only bit. Writing a 1 to this bit will apply new slew, tx_term, twpst1, eqen, eqadapten, swing, eqftc, eqlev settings to the clock and data lanes. Writes to the respective registers do not take immediate effect. This bit does not need to be written if I <sup>2</sup> C configuration occurs while OE or hpd_sink are low, I <sup>2</sup> C power down is active.	W
	1:0	2'b01	DEV_FUNC_MODE: This field selects the device working function mode. 00 – Redriver mode across full range 250 Mbps to 3.4-Gbps <b>01 - Automatic redriver to retimer crossover at 1.0 Gbps (default)</b> 10 - Reserved 11 - Retimer mode across full range 250 Mbps to 3.4-Gbps When changing crossover point, need to toggle PD_EN or toggle external HPD_SNK.	RW

**Mode Selection Definition:** This bit lets the receiver know where the device is located in a system for the purpose of centering the AEQ point. The SNx5DP149 is targeting the source application, so the default value is 0, which will center the EQ at 6.5 to 7.5-dB, see 表 9. If the SNx5DP149 is in a dock or sink application, the value should be changed to a value of 1, which will center the EQ at 12 to 13-dB.

### 9.5.4.2.3 HDMI Control

**表 8. HDMI Control**

ADDRESS	BIT	DEFAULT	DESCRIPTION	ACCESS
0Bh	7:6	2'b00	SLEW_CTL. Slew rate control. 2'00 is fastest and 2'b11 is slowest Writes ignored when I2C_EN/PIN = 0	RWU
	5	1'b0	HDMI_SEL: Contro; Writes ignored when I2C_EN/PIN = 0 <b>0 – HDMI (default)</b> 1 – DVI	RWU
	4:3	2'b00	TX_TERM_CTL: Controls termination for HDMI TX <b>00 – No termination</b> 01 – 150 to 300-Ω 10 – Reserved 11 - Reserved	RWU
	2	1'b0	Reserved	R
	1	1'b0	. Reserved	R
	0	1'b0	Reserved	R
0Ch	7:5	3'b000	VSWING_DATA: Data output swing control <b>000 – Vsadj set</b> 001 – Increase by 7% 010 – Increase by 14% 011 – Increase by 21% 100 – Decrease by 30% 101 – Decrease by 21% 110 – Decrease by 14% 111 – Decrease by 7%	RW
	4:2	3'b000	VSWING_CLK: Clock Output Swing Control <b>000 – Vsadj set</b> 001 – Increase by 7% 010 – Increase by 14% 011 – Increase by 21% 100 – Decrease by 30% 101 – Decrease by 21% 110 – Decrease by 14% 111 – Decrease by 7% Note: Default is set by DR, which means standard based swing values but this allows for the swing to be overridden by selecting one of these values	RW
	1:0	2'b00	HDMI_TWPST1. HDMI de-emphasis FIR post-cursor-1 signed tap weight. <b>00 – No de-emphasis</b> 01 – 2-dB de-emphasis 10 – Reserved 11 – Reserved	RWU

**9.5.4.2.4 Equalization Control Register**
**表 9. Equalization Control Register**

ADDRESS	BIT	DEFAULT	DESCRIPTION	ACCESS
0Dh	7:6	2'b00	Reserved	RW
	5:3	1'b000	<b>Data Lane EQ – Sets fixed EQ values</b> HDMI1.4b[2] <b>000 – 0-dB</b> 001 – 4.5-dB 010 – 6.5-dB 011 – 8.5-dB 100 – 10.5-dB 101 – 12-dB 110 – 14-dB 111 – 16.5-dB	RW
	2:1	1'b00	<b>Clock Lane EQ - Sets fixed EQ values</b> HDMI1.4b[2] <b>00 – 0-dB</b> 01 – 1.5-dB 10 – 3-dB 11 – RSVD	RW
	0	1'b0	Reserved	RW

**9.5.4.2.5 EyeScan Control Register**
**表 10. EyeScan Control Register**

ADDRESS	BITS	DEFAULT	DESCRIPTION	ACCESS
0Eh	7:4	4'b0000	PV_SYNC[3:0]. Pattern timing pulse. This field is updated for 8UI once every cycle of the PRBS generator. 1 bit per lane.	R
	3:0	4'b0000	PV_LD[3:0]. Load pattern-verifier controls into RX lanes. When asserted high, the PV_TO, PV_SEL, PV_LEN, PV_CP20, and PV_CP values are enabled into the corresponding RX lane. These values are then latched and held when PV_LD[n] is subsequently de-asserted low. 1 bit per lane.	RWU
0Fh	7:4	4'b0000	PV_FAIL[3:0]. Pattern verification mismatch detected. 1 bit per lane.	RU
	3:0	4'b0000	PV_TIP[3:0]. Pattern search/training in progress. 1 bit per lane.	RU
10h	7	1'b0	PV_CP20. Customer pattern length 20 or 16 bits. <b>0 – 16 bits</b> 1 – 20 bits	RW
	6	1'b0	Reserved	R
	5:3	3'b000	PV_LEN[2:0]. PRBS pattern length <b>000 – PRBS7</b> 001 – PRBS11 010 – PRBS23 011 – PRBS31 100 – PRBS15 101 – PRBS15 110 – PRBS20 111 – PRBS20	RW
	2:0	3'b000	PV_SEL[24:0]. Pattern select control <b>000 – Disabled</b> 001 – PRBS 010 – Clock 011 – Custom 1xx – Timing only mode with sync pulse spacing defined by PV_LEN	RW
11h	7:0	'h00	PV_CP[7:0]. Custom pattern data.	RW
12h	7:0	'h00	PV_CP[15:8]. Custom pattern data.	RW
13h	7:4	4'b0000	Reserved	R
	3:0	4'b0000	PV_CP[19:16]. Custom pattern data. Used when PV_CP20 = 1'b1.	RW

**表 10. EyeScan Control Register (continued)**

ADDRESS	BITS	DEFAULT	DESCRIPTION	ACCESS
14h	7:3	5'b00000	Reserved	R
	2:0	3'b000	PV_THR[2:0]. Pattern-verifier retain threshold.	RW
15h	7	1'b0	DESKEW_CMPLT: Indicates TMDS lane deskew has completed when high	R
	6:5	2'b00	Reserved	R
	4	1'b0	BERT_CLR. Clear BERT counter (on rising edge).	RSU
	3	1'b0	TST_INTQ_CLR. Clear latched interrupt flag.	RSU
	2:0	3'b000	TST_SEL[2:0]. Test interrupt source select.	RW
16h	7:4	4'b0000	PV_DP_EN[3:0]. Enabled datapath verified based on DP_TST_SEL, 1 bit per lane.	RW
	3	1'b0	Reserved	R
	2:0	3'b000	DP_TST_SEL[2:0] Selects pattern reported by BERT_CNT[11:0], TST_INT[0] and TST_INTQ[0]. PV_DP_EN is non-zero <b>000 – TMDS disparity or data errors</b> 001 – FIFO errors 010 – FIFO overflow errors 011 – FIFO underflow errors 100 – TMDS deskew status 101 – Reserved 110 – Reserved 111 – Reserved	RW
17h	7:4	4'b0000	TST_INTQ[3:0]. Latched interrupt flag. 1 bit per lane	RU
	3:0	4'b0000	TST_INT[3:0]. Test interrupt flag. 1 bit per lane.	RU
18h	7:0	'h00	BERT_CNT[7:0]. BERT error count. Lane 0	RU
19h	7:4	4'b0000	Reserved	R
	3:0	4'b0000	BERT_CNT[11:8]. BERT error count. Lane 0	RU
1Ah	7:0	'h00	BERT_CNT[19:12]. BERT error count. Lane 1	RU
1Bh	7:4	4'b0000	Reserved	R
	3:0	4'b0000	BERT_CNT[23:20]. BERT error count. Lane 1	RU
1Ch	7:0	'h00	BERT_CNT[31:24]. BERT error count. Lane 2	RU
1Dh	7:4	4'b0000	Reserved	R
	3:0	4'b0000	BERT_CNT[35:32]. BERT error count. Lane 2	RU
1Eh	7:0	'h00	BERT_CNT[19:12]. BERT error count. Lane 3	RU
1Fh	7:4	4'b0000	Reserved	R
	3:0	'h00	BERT_CNT[23:20]. BERT error count. Lane 3	RU
20h	7	1'b0	Power Down Status Bit <b>0 – Normal Operation</b> 1 – Device in Power Down Mode	R
	6	1'b0	Standby Status Bit <b>0 – Normal Operation</b> 1 – Device in Standby Mode	R
	5:0	6'b000000	Reserved	R

## 10 Application and Implementation

---

### 注

Information in the following applications sections is not part of the TI component specification, and TI does not warrant its accuracy or completeness. TI's customers are responsible for determining suitability of components for their purposes. Customers should validate and test their design implementation to confirm system functionality.

---

### 10.1 Application Information

#### 10.1.1 Use Case of SNx5DP149

SNx5DP149 can be used on the motherboard and dongle applications. The following use case diagrams show the connection of DDC between source side and sink side. The control pin pull up and pull down resistors are shown from reference. If a high is needed only use the pull up. If a low is needed only use the pull down. If mid level is to be selected do not use either resistors and leave the pin floating/No connect. The 6.5-K $\Omega$  Vsadj resistor value shown is explained further in the compliance section.

 28 shows the original connection of SNx5DP149 on motherboard through the DDC channel. The DDC DR default is 100-kHz and is capable to adjust to 400-kHz.

Application Information (continued)

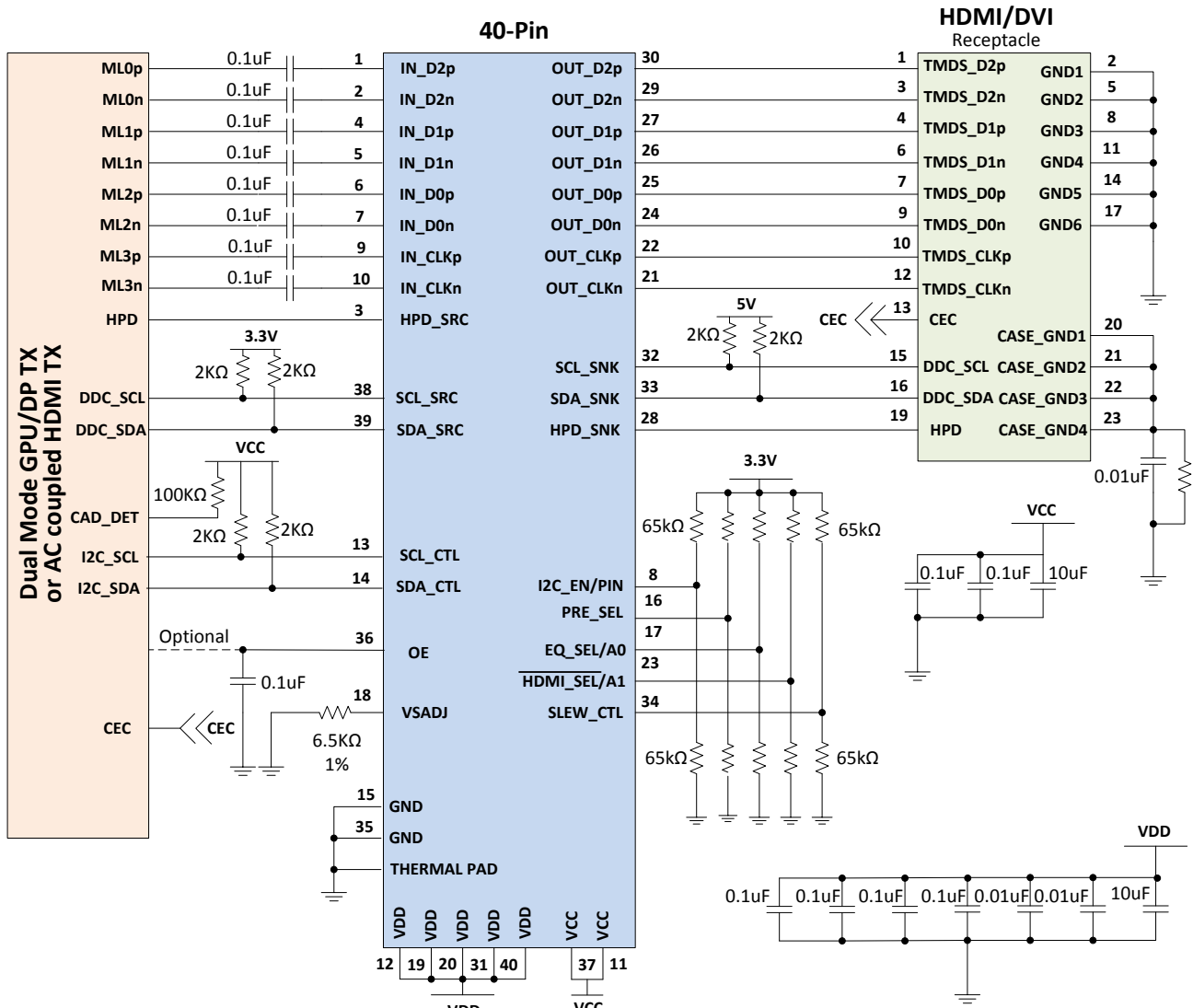

Copyright © 2016, Texas Instruments Incorporated

28. Implementation for Motherboard

## Application Information (continued)

shows the SNx5DP149 in the dongle application. It uses the unified structure on DisplayPort connector.

### 10.1.2 DDC Pullup Resistors

---

注

This section is for information only and subject to change depending upon system implementation.

---

## Application Information (continued)

The pullup resistor value is determined by two requirements:

- A. The maximum sink current of the I<sup>2</sup>C buffer:

The maximum sink current is 3-mA or slightly higher for an I<sup>2</sup>C driver supporting standard-mode I<sup>2</sup>C[4] operation.

$$R_{up(min)} = \frac{V_{CC}}{I_{sink}} \quad (1)$$

- B. The maximum transition time on the bus:

The maximum transition time, T, of an I<sup>2</sup>C bus is set by an RC time constant, where R is the pullup resistor value, and C is the total load capacitance. The parameter, k, can be calculated from 式 3 by solving for t, the times at which certain voltage thresholds are reached. Different input threshold combinations introduce different values of t. 表 11 summarizes the possible values of k under different threshold combinations.

$$T = k \times RC \quad (2)$$

$$V(t) = V_{CC} \times \left( 1 - e^{-\frac{t}{RC}} \right) \quad (3)$$

**表 11. Value k Upon Different Input Threshold Voltages**

V <sub>th</sub> -V <sub>th+</sub>	0.7 V <sub>CC</sub>	0.65 V <sub>CC</sub>	0.6 V <sub>CC</sub>	0.55 V <sub>CC</sub>	0.5 V <sub>CC</sub>	0.45 V <sub>CC</sub>	0.4 V <sub>CC</sub>	0.35 V <sub>CC</sub>	0.3 V <sub>CC</sub>
0.1 V <sub>CC</sub>	1.0986	0.9445	0.8109	0.6931	0.5878	0.4925	0.4055	0.3254	0.2513
0.15 V <sub>CC</sub>	1.0415	0.8873	0.7538	0.6360	0.5306	0.4353	0.3483	0.2683	0.1942
0.2 V <sub>CC</sub>	0.9808	0.8267	0.6931	0.5754	0.4700	0.3747	0.2877	0.2076	0.1335
0.25 V <sub>CC</sub>	0.9163	0.7621	0.6286	0.5108	0.4055	0.3102	0.2231	0.1431	0.0690
0.3 V <sub>CC</sub>	0.8473	0.6931	0.5596	0.4418	0.3365	0.2412	0.1542	0.0741	

From 式 1,  $R_{up(min)} = 5.5\text{-V} / 3\text{-mA} = 1.83\text{-k}\Omega$  to operate the bus under a 5-V pullup voltage and provide less than 3-mA when the I<sup>2</sup>C device is driving the bus to a low state. If a higher sink current, for example 4 mA, is allowed,  $R_{up(min)}$  can be as low as 1.375-k $\Omega$ .

If DDC is working at a standard mode of 100-Kbps, the maximum transition time, T, is fixed, 1  $\mu$ s, and using the k values from 表 11, the recommended maximum total resistance of the pullup resistors on an I<sup>2</sup>C bus can be calculated for different system setups. If DDC is working in a fast mode of 400-kbps, the transition time should be set at 300 ns, according to I<sup>2</sup>C[4] specification.

To support the maximum load capacitance specified in the HDMI specification,  $C_{cable(max)} = 700\text{-pF}$ ,  $C_{source} = 50\text{-pF}$ ,  $C_i = 50\text{-pF}$ , and  $R_{(max)}$  can be calculated as shown in 表 12.

**表 12. Pullup Resistor Upon Different Threshold Voltages and 800-pF Loads**

V <sub>th</sub> -V <sub>th+</sub>	0.7 V <sub>CC</sub>	0.65 V <sub>CC</sub>	0.6 V <sub>CC</sub>	0.55 V <sub>CC</sub>	0.5 V <sub>CC</sub>	0.45 V <sub>CC</sub>	0.4 V <sub>CC</sub>	0.35 V <sub>CC</sub>	0.3 V <sub>CC</sub>	UNIT
0.1 V <sub>CC</sub>	1.14	1.32	1.54	1.8	2.13	2.54	3.08	3.84	4.97	k $\Omega$
0.15 V <sub>CC</sub>	1.2	1.41	1.66	1.97	2.36	2.87	3.59	4.66	6.44	k $\Omega$
0.2 V <sub>CC</sub>	1.27	1.51	1.8	2.17	2.66	3.34	4.35	6.02	9.36	k $\Omega$
0.25 V <sub>CC</sub>	1.36	1.64	1.99	2.45	3.08	4.03	5.6	8.74	18.12	k $\Omega$
0.3 V <sub>CC</sub>	1.48	1.8	2.23	2.83	3.72	5.18	8.11	16.87	—	k $\Omega$

To accommodate the 3-mA drive current specification, a narrower threshold voltage range is required to support a maximum 800-pF load capacitance for a standard-mode I<sup>2</sup>C bus.

## 10.2 Typical Application

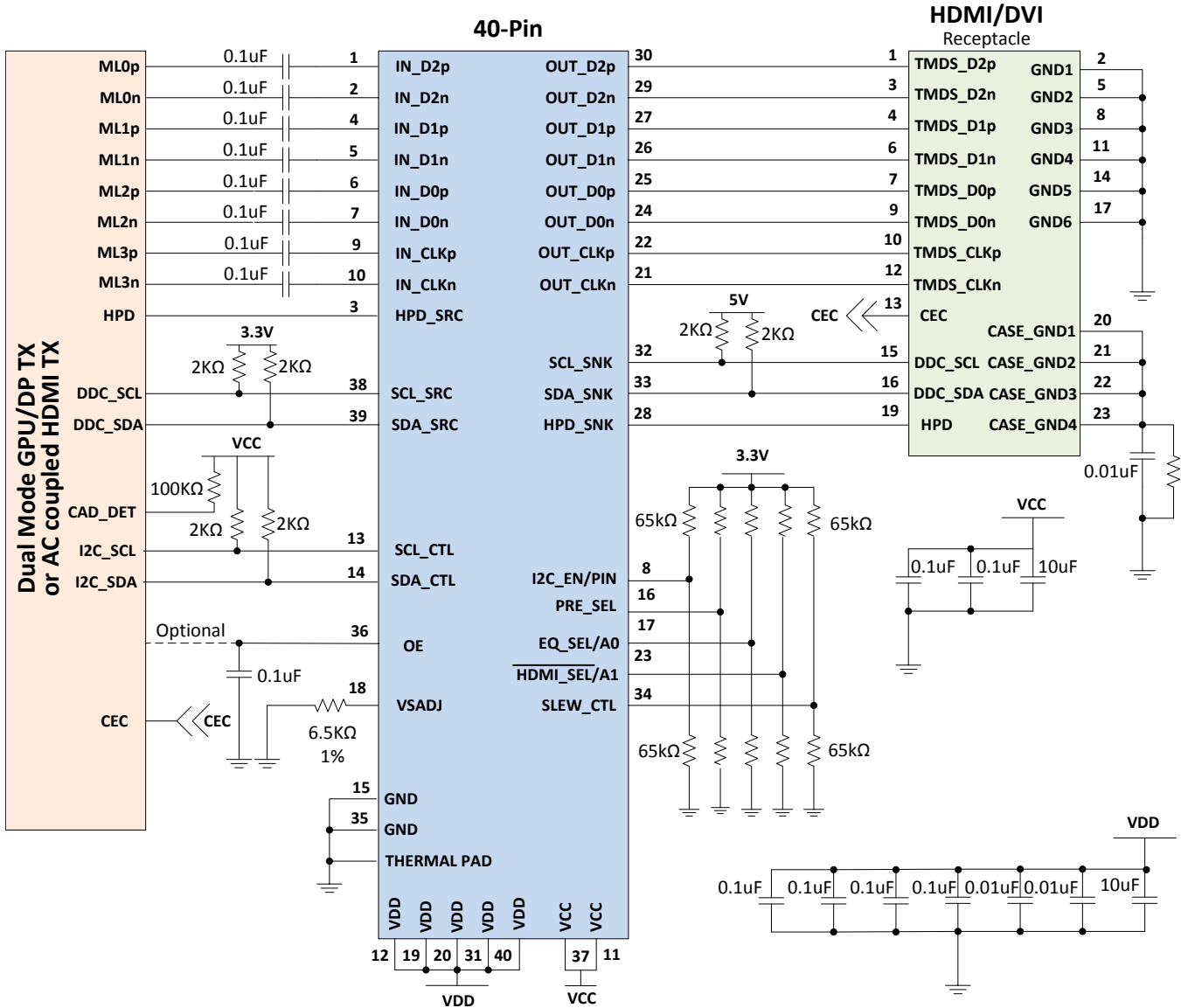

Copyright © 2016, Texas Instruments Incorporated

29. Implementation for Motherboard Schematic

### 10.2.1 Design Requirements

The SNx5DP149 can be designed into many types of applications. All applications have certain requirements for the system to work properly. Two voltage rails are required to support the lowest possible power consumption. The OE pin must have a 0.1-μF capacitor to ground. This pin can be driven by a processor but the pin needs to change states after voltage rails have stabilized. Configure the device by using I<sup>2</sup>C. Pin strapping is provided as I<sup>2</sup>C is not available in all cases. Because sources may have different naming conventions, confirm the link between the source and the SNx5DP149 is correctly mapped. A swap function is provided for the input pins in case signaling is reversed between the source and the device. For the control pins the values provided below are when they are being controlled by a micro-controller. If this is not the case then using the 65-kΩ for a pull up for high, pulled down for low, and left floating for mid level.

表 13. Design Parameters

DESIGN PARAMETER	VALUE
V <sub>CC</sub>	3.3 V
V <sub>DD</sub>	1.1 V
Main link input voltage	V <sub>ID</sub> = 75 mVpp to 1.2 Vpp
Control pin Low	65-kΩ pulled to GND
Control pin Mid	No Connect
Control pin High	65-kΩ pulled to 3.3-V
Vsadj resistor	7.06-kΩ
Main link AC decoupling capacitor	75 to 200 nF, recommend 100 nF

### 10.2.2 Detailed Design Procedure

The SNx5DP149 is a signal conditioner that provides AC coupling to DC coupling level shifting, to support Dual Mode DisplayPort-capable GPUs or GPUs with AC-coupled drive capability to support HDMI or DVI connectors and compliance. Signal conditioning is accomplished using receive equalization, retiming, and output driver configurability. The transmitter drives 2 to 3 inches of board trace and connector.

Designing in the SNx5DP149 requires the following:

- Determine the loss profile between the GPU and the HDMI/DVI connector.
- Based upon the loss profile and signal swing, determine the optimal location for the SNx5DP149, to pass electrical compliance.
- Use the typical application drawings in [Use Case of SNx5DP149](#) for information on using the AC coupling capacitors and control pin resistors.
- The DP149 has a receiver adaptive equalizer by default but can also be configured for fixed value equalization using the EQ\_SEL control pin.
- Set the VOD, pre-emphasis, termination, and edge rate levels to support compliance by using the appropriate Vsadj resistor value and by setting the PRE\_SEL and SLEW\_CTL control pins.
- The thermal pad must be connected to ground.
- See the schematics in [Application Information](#) on recommended decouple capacitors from VCC pins to ground.

### 10.2.3 Application Curves

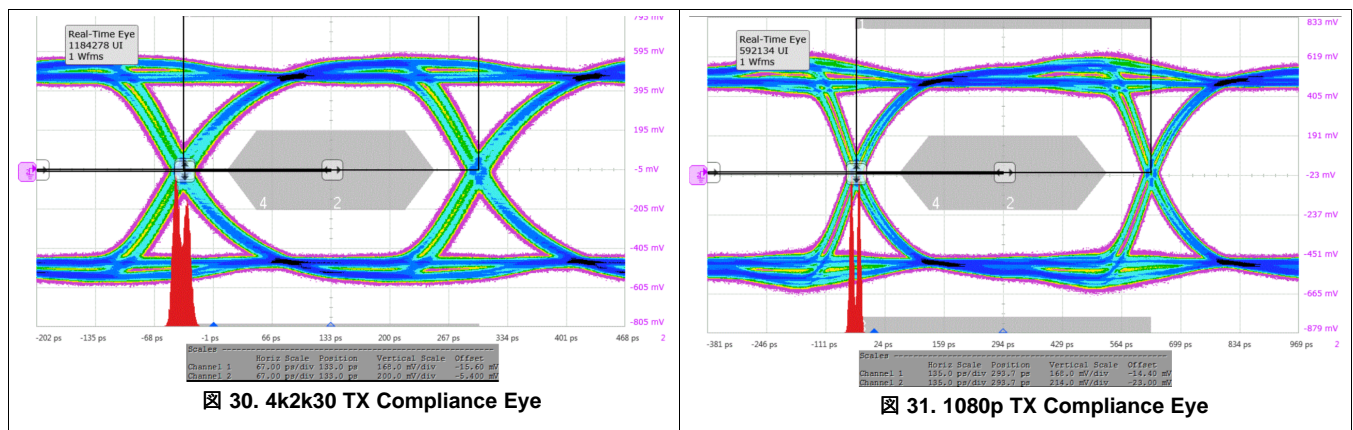

## 10.3 System Example

### 10.3.1 Compliance Testing

Compliance testing is very system design specific. Properly designing the system and configuring the DP149 can help pass transmitter compliance for the system. The following information is the starting point to help prepare for compliance test. As each system is different there are many features in the DP149 to help tune the circuit. These include  $V_{OD}$  adjust by changing the  $V_{sadj}$  resistor value or using I<sup>2</sup>C. Other knobs to turn are pre/de-emphasis and slew rate control. Passing HDMI1.4b compliance is easier to accomplish when using I<sup>2</sup>C as this provides more fine tuning capability.

#### For the SNx5DP149RSB:

##### Pin Strapping

HDMI1.4b

$V_{sadj}$  Resistor = 6.5 k $\Omega$

PRE\_SEL = L for –2 dB

SLEW\_CTL = NC

##### I<sup>2</sup>C

##### HDMI1.4b

$V_{sadj}$  Resistor = 6.5 k $\Omega$

VSWING\_DATA & VSWING\_CLK to -7% = Reg0Ch[7:2] = 111111

PRE\_SEL = Reg0Ch[1:0] = 00: (Labeled HDMI\_TWPST)

TX\_TERM\_CTL: Reg0Bh[4:3]

- <2 Gbps = 00 for no termination (This may be best value for all HDMI1.4b)
- >2 Gbps and < 3.4 Gbps = 01 for 150 to 300  $\Omega$

SLEW\_CTL = Reg0Bh[7:6] = 10

## 11 Power Supply Recommendations

### 11.1 Power Management

To minimize the power consumption of customer application, SNx5DP149 uses dual power supply.  $V_{CC}$  is 3.3-V with 10% range to support the I/O voltage. The  $V_{DD}$  is 1.00-V to 1.27-V range to supply the internal digital control circuit.  $v$  operates in two different working states. See 表 15 for conditions for each mode. When OE is deasserted and then reasserted the device will rest to its default configurations. If different configurations were programmed using I<sup>2</sup>C then the device will have to be reprogrammed.

- Power-down mode:
  - OE = Low puts the device into its lowest power state by shutting down all function blocks
    - When OE is re-asserted the transitions from L → H will create a reset and if the device is programmed through I<sup>2</sup>C it will have to be reprogrammed.
    - OE = High, HPD\_SNK = Low
    - Writing a 1 to register 09h[3]
- Normal operation: Working in redriver or retimer
- When HPD asserts, the device CDR and output will enable based on the signal detector circuit result
- HPD\_SRC = HPD\_SNK in all conditions. The HPD channel operational when  $V_{CC}$  over 3-V.

表 14. Control Logic and Mode of Operation

INPUTS <sup>(1)</sup>		STATUS							MODE
HPD_SNK	OE	Mode of Operation	HPD_SRC	IN_Dx	SDA_CTL SCL_CTL	OUT_Dx OUT_CLK	DDC	AUX_SRC± (48 PIN ONLY)	
H	L	X	H	High-Z	Disabled	High-Z	Disabled	Disable	Power-down mode
L	H	X	L	High-Z	Active	High-Z	Disabled	Disable	Power-down mode
H	H	X	H	High-Z	Active	High-Z	Disabled	Disable	Power-down mode when a one is written to 09h[3]
H	H	Redriver	H	RX active	Active	TX active	Active	Active	Normal operation
H	H	Retimer	H	RX active	Active	TX active	Active	Active	Normal operation

(1) L = LOW, H = HIGH

TMDS output termination control impacts the operating power.

表 15. Control Logic and Mode of Operation

INPUTS <sup>(1)</sup>		STATUS							MODE
HPD_SNK	OE	Mode of Operation	HPD_SRC	IN_Dx	SDA_CTL SCL_CTL	OUT_Dx OUT_CLK	DDC		
H	L	X	H	High-Z	Disabled	High-Z	Disabled	Power-down mode	
L	H	X	L	High-Z	Active	High-Z	Disabled	Power-down mode	
H	H	X	H	High-Z	Active	High-Z	Disabled	Power-down mode when a one is written to 09h[3]	
H	H	Redriver	H	RX active	Active	TX active	Active	Normal operation	
H	H	Retimer	H	RX active	Active	TX active	Active	Normal operation	

(1) L = LOW, H = HIGH

TMDS output termination control impacts the operating power.

## 12 Layout

### 12.1 Layout Guidelines

TI recommends to use at a minimum a four layer stack up to accomplish a low-EMI PCB design. TI recommends six layers because the SNx5DP149 is a two voltage rail device.

- Routing the high-speed input DisplayPort traces and TMDS output traces on the top layer avoids the use of vias (and their discontinuities) and allows for clean interconnects from the HDMI connectors to the repeater

**Layout Guidelines (continued)**

inputs and from the repeater output to the subsequent receiver circuit. It is important to match the electrical length of these high speed traces to minimize both inter-pair and intra-pair skew.

- Placing a solid ground plane next to the high-speed signal layer establishes controlled impedance for transmission line interconnects and provides an excellent low-inductance path for the return current flow.
- Placing the power plane next to the ground plane creates additional high-frequency bypass capacitance.
- Routing the slower speed control signals on the bottom layer allows for greater flexibility as these signal links usually have margin to tolerate discontinuities such as vias.
- If an additional supply voltage plane or signal layer is needed, add a second power / ground plane system to the stack to keep it symmetrical. This makes the stack mechanically stable and prevents it from warping. Also the power and ground plane of each power system can be placed closer together, thus increasing the high-frequency bypass capacitance significantly.
- The control pin pullup and pulldown resistors are shown in application section for reference. If a high is needed only use the pull up. If a low is needed only use the pull down. If mid level is to be selected do not use either resistors and leave the pin floating/No connect.

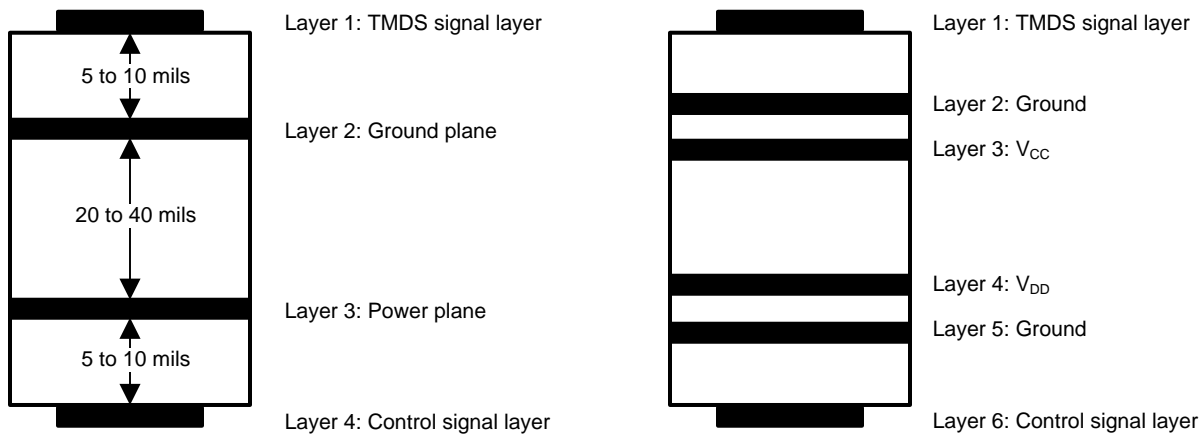

**32. Recommended 4- or 6-Layer Stack for a Receiver PCB Design**

## 12.2 Layout Example



图 33. Layout Example for the DP149RSB

## 12.3 Thermal Considerations

On a high-K board: TI recommends to solder the PowerPAD™ onto the thermal land. A thermal land is the area of solder-tinned-copper underneath the PowerPAD package. On a high-K board, the SNx5DP149 device can operate over the full temperature range by soldering the PowerPAD onto the thermal land without vias.

On a low-K board: For the device to operate across the temperature range on a low-K board, a 1-oz Cu trace connecting the GND pins to the thermal land must be used. A simulation shows  $R_{\theta JA} = 100.84^{\circ}\text{C/W}$  allowing 545-mW power dissipation at 70°C ambient temperature.

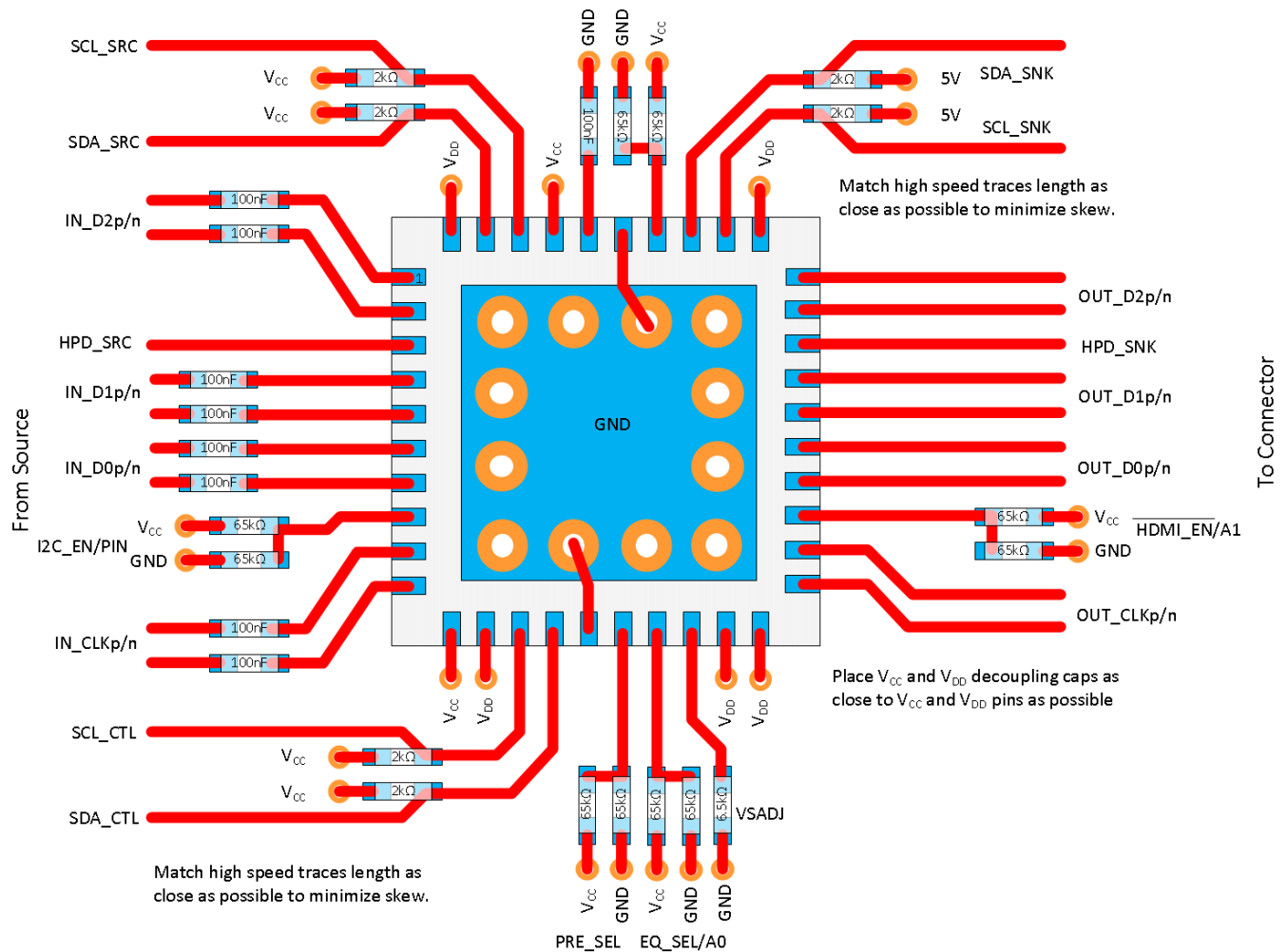
A general PCB design guide for PowerPAD packages is provided in *PowerPAD Thermally Enhanced Package, SLMA002*.

## 13 デバイスおよびドキュメントのサポート

### 13.1 関連リンク

次の表に、クイック・アクセス・リンクを示します。カテゴリには、技術資料、サポートおよびコミュニティ・リソース、ツールとソフトウェア、およびサンプル注文またはご購入へのクイック・アクセスが含まれます。

## 関連リンク (continued)

**表 16. 関連リンク**

製品	プロダクト・フォルダ	サンプルとご購入	技術資料	ツールとソフトウェア	サポートとコミュニティ
SN65DP149	<a href="#">ここをクリック</a>	<a href="#">ここをクリック</a>	<a href="#">ここをクリック</a>	<a href="#">ここをクリック</a>	<a href="#">ここをクリック</a>
SN75DP149	<a href="#">ここをクリック</a>	<a href="#">ここをクリック</a>	<a href="#">ここをクリック</a>	<a href="#">ここをクリック</a>	<a href="#">ここをクリック</a>

## 13.2 ドキュメントのサポート

### 13.2.1 関連資料

このセクションに記載するドキュメントは、このデータシートで参照されているものです。データシート内の参照のほとんどは、テキストの簡素化のため、ドキュメントの完全なタイトルを記載する代わりに、角括弧を使用して[ドキュメントのタグ]形式で記載されています。

- (1) [デュアル・モード] VESA DisplayPortデュアル・モード標準バージョン1.1、2013年2月8日
- (2) [HDMI1.4b] 高解像度マルチメディア・インターフェイス仕様バージョン1.4b、2011年10月
- (3) [HDMI2.0] 高解像度マルチメディア・インターフェイス仕様バージョン 2.0a、2015年3月
- (4) [I<sup>2</sup>C] I<sup>2</sup>Cバス仕様バージョン2.1、2000年1月
- (5) [HDMI1.4b CTS] 高解像度マルチメディア・インターフェイスCTSバージョン 1.4b、2011年10月
- (6) [HDMI2.0 CTS] 高解像度マルチメディア・インターフェイスCTSバージョン2.0k、2015年6月

### 13.3 ドキュメントの更新通知を受け取る方法

ドキュメントの更新についての通知を受け取るには、[ti.com](http://ti.com)のデバイス製品フォルダを開いてください。右上の隅にある「通知を受け取る」をクリックして登録すると、変更されたすべての製品情報に関するダイジェストを毎週受け取れます。変更の詳細については、修正されたドキュメントに含まれている改訂履歴をご覧ください。

### 13.4 コミュニティ・リソース

The following links connect to TI community resources. Linked contents are provided "AS IS" by the respective contributors. They do not constitute TI specifications and do not necessarily reflect TI's views; see TI's [Terms of Use](#).

**TI E2E™オンライン・コミュニティ** TIのE2E ( *Engineer-to-Engineer* ) コミュニティ。エンジニア間の共同作業を促進するために開設されたものです。e2e.ti.comでは、他のエンジニアに質問し、知識を共有し、アイデアを検討して、問題解決に役立てることができます。

**設計サポート** TIの設計サポート役に立つE2Eフォーラムや、設計サポート・ツールをすばやく見つけることができます。技術サポート用の連絡先情報も参照できます。

### 13.5 商標

PowerPAD, E2E are trademarks of Texas Instruments.  
DisplayPort is a trademark of VESA.  
All other trademarks are the property of their respective owners.

### 13.6 静電気放電に関する注意事項



すべての集積回路は、適切なESD保護方法を用いて、取扱いと保存を行うようにして下さい。

静電気放電はわずかな性能の低下から完全なデバイスの故障に至るまで、様々な損傷を与えます。高精度の集積回路は、損傷に対して敏感であり、極めてわずかなパラメータの変化により、デバイスに規定された仕様に適合しなくなる場合があります。

### 13.7 Glossary

**SLYZ022** — TI Glossary.

This glossary lists and explains terms, acronyms, and definitions.

## 14 メカニカル、パッケージ、および注文情報

以降のページには、メカニカル、パッケージ、および注文に関する情報が記載されています。この情報は、そのデバイスについて利用可能な最新のデータです。このデータは予告なく変更されることがあり、ドキュメントが改訂される場合もあります。本データシートのブラウザ版を使用されている場合は、画面左側の説明をご覧ください。

**PACKAGING INFORMATION**

Orderable part number	Status (1)	Material type (2)	Package   Pins	Package qty   Carrier	RoHS (3)	Lead finish/ Ball material (4)	MSL rating/ Peak reflow (5)	Op temp (°C)	Part marking (6)
<a href="#">SN65DP149RSBR</a>	Active	Production	WQFN (RSB)   40	3000   LARGE T&R	Yes	NIPDAU	Level-1-260C-UNLIM	-40 to 85	DP149
SN65DP149RSBR.A	Active	Production	WQFN (RSB)   40	3000   LARGE T&R	Yes	NIPDAU	Level-1-260C-UNLIM	-40 to 85	DP149
<a href="#">SN65DP149RSBT</a>	Active	Production	WQFN (RSB)   40	250   SMALL T&R	Yes	NIPDAU	Level-1-260C-UNLIM	-40 to 85	DP149
SN65DP149RSBT.A	Active	Production	WQFN (RSB)   40	250   SMALL T&R	Yes	NIPDAU	Level-1-260C-UNLIM	-40 to 85	DP149
<a href="#">SN75DP149RSBR</a>	Active	Production	WQFN (RSB)   40	3000   LARGE T&R	Yes	NIPDAU	Level-1-260C-UNLIM	0 to 70	75DP149
SN75DP149RSBR.A	Active	Production	WQFN (RSB)   40	3000   LARGE T&R	Yes	NIPDAU	Level-1-260C-UNLIM	0 to 70	75DP149
<a href="#">SN75DP149RSBT</a>	Active	Production	WQFN (RSB)   40	250   SMALL T&R	Yes	NIPDAU	Level-1-260C-UNLIM	0 to 70	75DP149
SN75DP149RSBT.A	Active	Production	WQFN (RSB)   40	250   SMALL T&R	Yes	NIPDAU	Level-1-260C-UNLIM	0 to 70	75DP149

(1) **Status:** For more details on status, see our [product life cycle](#).

(2) **Material type:** When designated, preproduction parts are prototypes/experimental devices, and are not yet approved or released for full production. Testing and final process, including without limitation quality assurance, reliability performance testing, and/or process qualification, may not yet be complete, and this item is subject to further changes or possible discontinuation. If available for ordering, purchases will be subject to an additional waiver at checkout, and are intended for early internal evaluation purposes only. These items are sold without warranties of any kind.

(3) **RoHS values:** Yes, No, RoHS Exempt. See the [TI RoHS Statement](#) for additional information and value definition.

(4) **Lead finish/Ball material:** Parts may have multiple material finish options. Finish options are separated by a vertical ruled line. Lead finish/Ball material values may wrap to two lines if the finish value exceeds the maximum column width.

(5) **MSL rating/Peak reflow:** The moisture sensitivity level ratings and peak solder (reflow) temperatures. In the event that a part has multiple moisture sensitivity ratings, only the lowest level per JEDEC standards is shown. Refer to the shipping label for the actual reflow temperature that will be used to mount the part to the printed circuit board.

(6) **Part marking:** There may be an additional marking, which relates to the logo, the lot trace code information, or the environmental category of the part.

Multiple part markings will be inside parentheses. Only one part marking contained in parentheses and separated by a "-" will appear on a part. If a line is indented then it is a continuation of the previous line and the two combined represent the entire part marking for that device.

**Important Information and Disclaimer:** The information provided on this page represents TI's knowledge and belief as of the date that it is provided. TI bases its knowledge and belief on information provided by third parties, and makes no representation or warranty as to the accuracy of such information. Efforts are underway to better integrate information from third parties. TI has taken and continues to take reasonable steps to provide representative and accurate information but may not have conducted destructive testing or chemical analysis on incoming materials and chemicals. TI and TI suppliers consider certain information to be proprietary, and thus CAS numbers and other limited information may not be available for release.

In no event shall TI's liability arising out of such information exceed the total purchase price of the TI part(s) at issue in this document sold by TI to Customer on an annual basis.

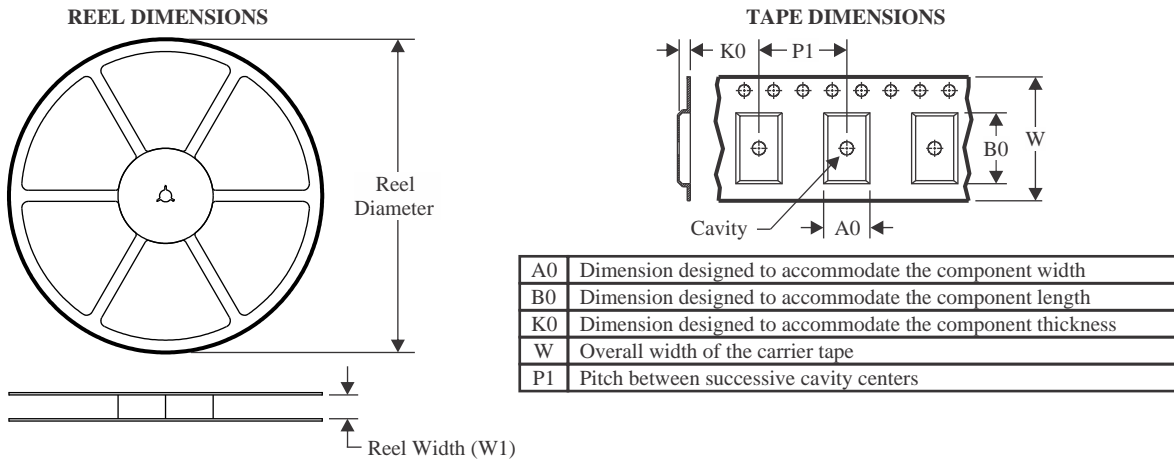
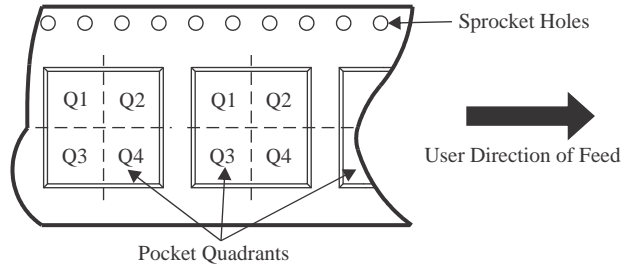
**TAPE AND REEL INFORMATION**

**QUADRANT ASSIGNMENTS FOR PIN 1 ORIENTATION IN TAPE**

\*All dimensions are nominal

Device	Package Type	Package Drawing	Pins	SPQ	Reel Diameter (mm)	Reel Width W1 (mm)	A0 (mm)	B0 (mm)	K0 (mm)	P1 (mm)	W (mm)	Pin1 Quadrant
SN65DP149RSBR	WQFN	RSB	40	3000	330.0	12.4	5.3	5.3	1.1	8.0	12.0	Q2
SN65DP149RSBT	WQFN	RSB	40	250	180.0	12.4	5.3	5.3	1.1	8.0	12.0	Q2
SN75DP149RSBR	WQFN	RSB	40	3000	330.0	12.4	5.3	5.3	1.1	8.0	12.0	Q2
SN75DP149RSBT	WQFN	RSB	40	250	180.0	12.4	5.3	5.3	1.1	8.0	12.0	Q2

## TAPE AND REEL BOX DIMENSIONS



\*All dimensions are nominal

Device	Package Type	Package Drawing	Pins	SPQ	Length (mm)	Width (mm)	Height (mm)
SN65DP149RSBR	WQFN	RSB	40	3000	346.0	346.0	33.0
SN65DP149RSBT	WQFN	RSB	40	250	182.0	182.0	20.0
SN75DP149RSBR	WQFN	RSB	40	3000	346.0	346.0	33.0
SN75DP149RSBT	WQFN	RSB	40	250	182.0	182.0	20.0

## GENERIC PACKAGE VIEW

**RSB 40**

**WQFN - 0.8 mm max height**

5 x 5 mm, 0.4 mm pitch

PLASTIC QUAD FLATPACK - NO LEAD

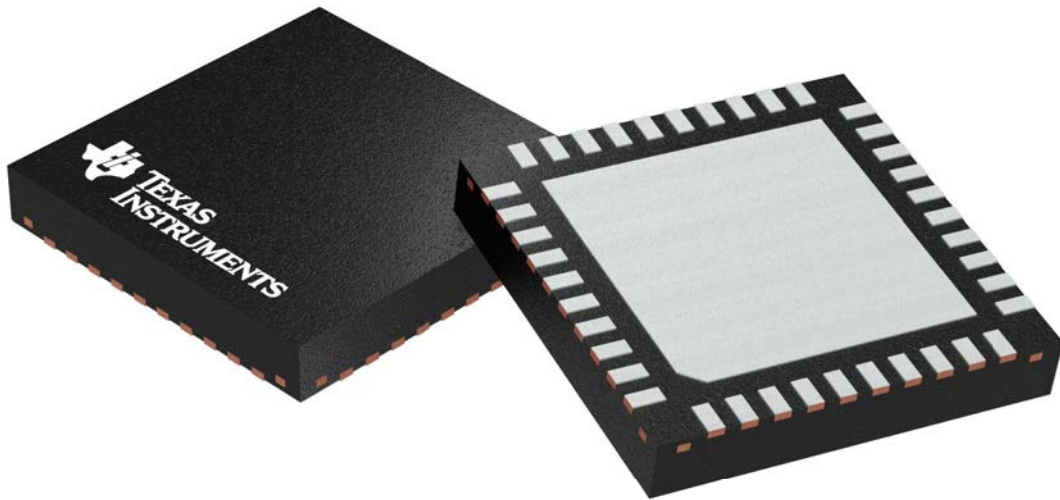

Images above are just a representation of the package family, actual package may vary.  
Refer to the product data sheet for package details.

4207182/D

## 重要なお知らせと免責事項

TI は、技術データと信頼性データ (データシートを含みます)、設計リソース (リファレンス デザインを含みます)、アプリケーションや設計に関する各種アドバイス、Web ツール、安全性情報、その他のリソースを、欠陥が存在する可能性のある「現状のまま」提供しており、商品性および特定目的に対する適合性の黙示保証、第三者の知的財産権の非侵害保証を含むいかなる保証も、明示的または黙示的にかかわらず拒否します。

これらのリソースは、TI 製品を使用する設計の経験を積んだ開発者への提供を意図したものです。(1) お客様のアプリケーションに適した TI 製品の選定、(2) お客様のアプリケーションの設計、検証、試験、(3) お客様のアプリケーションに該当する各種規格や、その他のあらゆる安全性、セキュリティ、規制、または他の要件への確実な適合に関する責任を、お客様のみが単独で負うものとし、

上記の各種リソースは、予告なく変更される可能性があります。これらのリソースは、リソースで説明されている TI 製品を使用するアプリケーションの開発の目的でのみ、TI はその使用をお客様に許諾します。これらのリソースに関して、他の目的で複製することや掲載することは禁止されています。TI や第三者の知的財産権のライセンスが付与されている訳ではありません。お客様は、これらのリソースを自身で使用した結果発生するあらゆる申し立て、損害、費用、損失、責任について、TI およびその代理人を完全に補償するものとし、TI は一切の責任を拒否します。

TI の製品は、[TI の販売条件](#)、[TI の総合的な品質ガイドライン](#)、[ti.com](#) または TI 製品などに関連して提供される他の適用条件に従い提供されます。TI がこれらのリソースを提供することは、適用される TI の保証または他の保証の放棄の拡大や変更を意味するものではありません。TI がカスタム、またはカスタマー仕様として明示的に指定していない限り、TI の製品は標準的なカタログに掲載される汎用機器です。

お客様がいかなる追加条項または代替条項を提案する場合も、TI はそれらに異議を唱え、拒否します。

Copyright © 2026, Texas Instruments Incorporated

最終更新日 : 2025 年 10 月