

# SN65HVD7x 3.3V 電源、全二重 RS-485 トランシーバ、±12kV IEC ESD 保護付き

## 1 特長

- 1/8 単位負荷のオプションを提供
  - バス上に最大 256 個のノード
- バス I/O 保護
  - ±30kV を超える HBM 保護
  - ±12kV を超える IEC 61000-4-2 接触放電
  - ±4kV を超える IEC 61000-4-4 高速過渡バースト
- 拡張産業用温度範囲：
  - 40°C ~ 125°C
- レシーバの大きなヒステリシス (70mV) によるノイズ除去
- 低消費電力
  - 動作中の静止電流 1.1mA 未満
  - 低いスタンバイ時消費電流: 標準値 10nA、最大値 5µA 未満
- 電源オンおよび電源オフ時のグリッチ・フリー保護によりホットプラグ・アプリケーションに対応
- 5V 許容のロジック入力、3.3V または 5V のコントローラと互換
- 信号速度オプション：
  - 400kbps (70, 71)、20Mbps (73, 74)、50Mbps (76, 77) に対して最適化

## 2 アプリケーション

- e マーター
- 産業用オートメーション
- ビルディング・オートメーション
- セキュリティと監視
- エンコーダ / デコーダ

## 3 概要

これらのデバイスは、堅牢な 3.3V ドライバおよびレシーバと高レベルの ESD 保護を備えた全二重トランシーバ・ファミリとして、RS-485 ポートフォリオを拡張します。ESD 保護機能には、±30kV を超える HBM、±12kV を超える IEC61000-4-2 接触放電が含まれます。SN65HVD7x デバイスの大きなレシーバ・ヒステリシスは伝導差動ノイズに対する耐性を実現し、その広い温度範囲は過酷な動作環境での高い信頼性を可能にします。SN65HVD7x デバイスは、標準の SOIC パッケージに加えて、占有面積の小さい MSOP パッケージでも提供しています。

これらのデバイスはそれぞれ差動ドライバと差動レシーバを組み合わせたものであり、3.3V 単一電源で動作します。各ドライバおよびレシーバは、全二重バス通信設計用に、独立した入力および出力ピンを備えています。これらのデバイスはいずれも同相電圧範囲が広いため、長いケーブルを使用するマルチポイント・アプリケーションに適しています。

SN65HVD71、SN65HVD74、SN65HVD77 デバイスは、外部イネーブル・ピンなしで完全にイネーブルになります。

SN65HVD70、SN65HVD73、SN65HVD76 デバイスは、アクティブ HIGH のドライバ・イネーブルと、アクティブ LOW のレシーバ・イネーブルを備えています。ドライバとレシーバの両方をディセーブルにすると、5µA 未満の低いスタンバイ電流が得られます。

これらのデバイスは、-40°C ~ 125°C で動作が規定されています。

### 製品情報<sup>(1)</sup>

型番	パッケージ	本体サイズ(公称)
SN65HVD71	MSOP (8)	3.00mmx3.00mm
SN65HVD74	SOIC (8)	4.90mmx3.91mm
SN65HVD77		
SN65HVD70	MSOP (10)	3.00mmx3.00mm
SN65HVD73	SOIC (14)	8.65mmx3.91mm
SN65HVD76		

(1) 利用可能なすべてのパッケージについては、このデータシートの末尾にある注文情報を参照してください。

### ブロック図

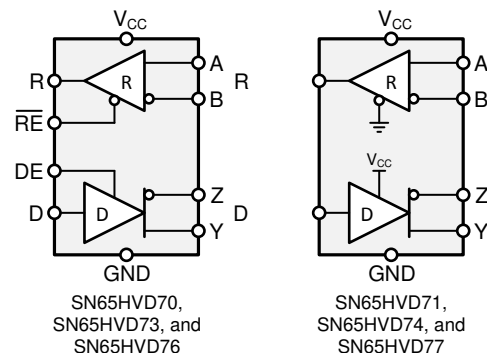

## 目次

1	特長	1	9.1	Overview	17
2	アプリケーション	1	9.2	Functional Block Diagram	17
3	概要	1	9.3	Feature Description	17
4	改訂履歴	2	9.4	Device Functional Modes	17
5	Device Comparison Table	3	10	Application and Implementation	20
6	Pin Configuration and Functions	4	10.1	Application Information	20
7	Specifications	7	10.2	Typical Application	20
7.1	Absolute Maximum Ratings	7	11	Power Supply Recommendations	26
7.2	ESD Ratings	7	12	Layout	26
7.3	Recommended Operating Conditions	7	12.1	Layout Guidelines	26
7.4	Thermal Information — D Packages	8	12.2	Layout Example	27
7.5	Thermal Information — DGS and DGK Packages	8	13	デバイスおよびドキュメントのサポート	28
7.6	Power Dissipation	8	13.1	デバイス・サポート	28
7.7	Electrical Characteristics	8	13.2	関連リンク	28
7.8	Switching Characteristics — 400 kbps	9	13.3	ドキュメントの更新通知を受け取る方法	28
7.9	Switching Characteristics — 20 Mbps	10	13.4	コミュニティ・リソース	28
7.10	Switching Characteristics — 50 Mbps	10	13.5	商標	28
7.11	Typical Characteristics	11	13.6	静電気放電に関する注意事項	28
8	Parameter Measurement Information	13	13.7	Glossary	28
9	Detailed Description	17	14	メカニカル、パッケージ、および注文情報	28

## 4 改訂履歴

資料番号末尾の英字は改訂を表しています。その改訂履歴は英語版に準じています。

Revision F (April 2019) から Revision G に変更	Page
• Changed device numbers to the 8-Pin DGK package image	4
• Changed device numbers to the 10-Pin DGS package image	5

Revision E (October 2014) から Revision F に変更	Page
• Changed the <i>Pin Configuration</i> images	4
• Changed the Supply Voltage MAX value From: 5.5 V To 5 V in the <i>Absolute Maximum Ratings</i>	7
• Moved Storage Temperature From the ESD table to the <i>Absolute Maximum Ratings</i>	7
• Changed the Handling Ratings table to <i>ESD Ratings</i>	7
• Added Note: to Supply voltage in the <i>Recommended Operating Conditions</i>	7

Revision D (August 2014) から Revision E に変更	Page
• Updated the MSOP–10 logic diagram	5

Revision C (July 2014) から Revision D に変更	Page
• Updated the <i>Device Comparison Table</i>	3

Revision B (July 2014) から Revision C に変更	Page
• Updated SN65HVD70 and SN65HVD71 specifications to production values	3

**Revision A (June 2014) から Revision B に変更 Page**

- Updated the *Device Comparison Table*..... **3**
- SN65HVD74 device status changed from *Product Preview* to *Production Data*..... **3**

**2014年5月発行のものから更新 Page**

- デバイスのステータスを「製品プレビュー」から混在ステータスの「量産データ」に変更 ..... **1**

## 5 Device Comparison Table

PART NUMBER <sup>(1)</sup>	SIGNALING RATE	DUPLEX	ENABLES	PACKAGE	NODES
SN65HVD70	up to 400 kbps	Full	DE, $\overline{RE}$	SOIC-14 MSOP-10	256
SN65HVD71	up to 400 kbps	Full	None	SOIC-8 MSOP-8	256
SN65HVD73	up to 20 Mbps	Full	DE, $\overline{RE}$	SOIC-14 MSOP-10	256
SN65HVD74	up to 20 Mbps	Full	None	SOIC-8 MSOP-8	256
SN65HVD76	up to 50 Mbps	Full	DE, $\overline{RE}$	SOIC-14 MSOP-10	96
SN65HVD77	up to 50 Mbps	Full	None	SOIC-8 MSOP-8	96

(1) For device status, see the [メカニカル、パッケージ、および注文情報](#) section.

## 6 Pin Configuration and Functions

SN65HVD71, SN65HVD74, SN65HVD77  
 8-Pin SOIC, D Package, and 8-Pin MSOP, DGK Package  
 (Top View)

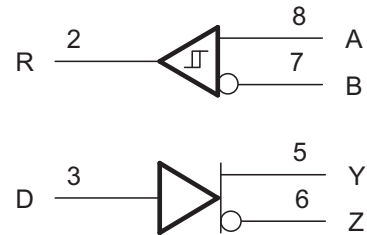
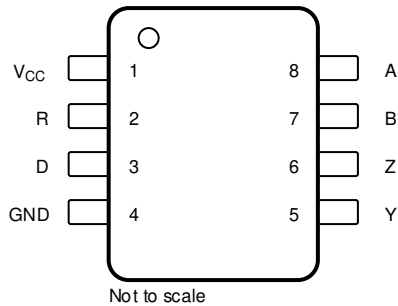

Pin Functions — SOIC-8 and MSOP-8

PIN		TYPE	DESCRIPTION
NAME	NO.		
V <sub>CC</sub>	1	Supply	3-V to 3.6-V supply
R	2	Digital output	Receive data output
D	3	Digital input	Driver data input
GND	4	Reference potential	Local device ground
Y	5	Bus output	Digital bus output, Y (Complementary to Z)
Z	6	Bus output	Digital bus output, Z (Complementary to Y)
B	7	Bus input	Digital bus input, B (Complementary to A)
A	8	Bus input	Digital bus input, A (Complementary to B)

**SN65HVD70, SN65HVD73, SN65HVD76**  
**10-Pin MSOP, DGS Package**  
**(Top View)**

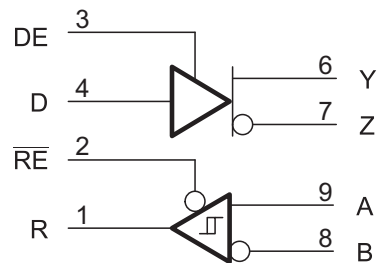
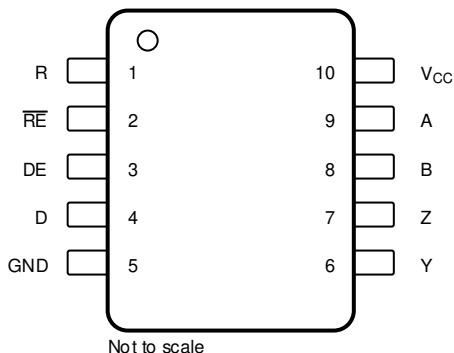

**Pin Functions — MSOP-10**

PIN		TYPE	DESCRIPTION
NAME	NO.		
R	1	Digital output	Receive data output
$\overline{RE}$	2	Digital input	Receive enable <i>Low</i>
DE	3	Digital input	Driver enable <i>High</i>
D	4	Digital input	Driver data input
GND	5	Reference potential	Local device ground
Y	6	Bus output	Digital bus output, Y (Complementary to Z)
Z	7	Bus output	Digital bus output, Z (Complementary to Y)
B	8	Bus input	Digital bus input, B (Complementary to A)
A	9	Bus input	Digital bus input, A (Complementary to B)
V <sub>CC</sub>	10	Supply	3-V to 3.6-V supply

SN65HVD70, SN65HVD73, SN65HVD76  
 14-Pin SOIC, D Package  
 (Top View)

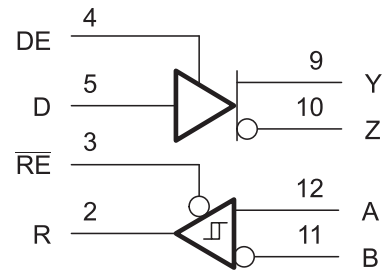
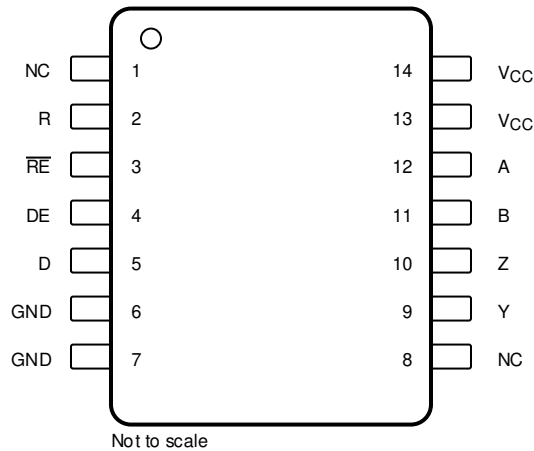

Pin Functions — SOIC-14

PIN		TYPE	DESCRIPTION
NAME	NO.		
NC	1	No connect	Not connected
	8		
R	2	Digital output	Receive data output
$\overline{RE}$	3	Digital input	Receive enable <i>Low</i>
DE	4	Digital input	Driver enable <i>High</i>
D	5	Digital input	Driver data input
GND	6 <sup>(1)</sup>	Reference potential	Local device ground
	7 <sup>(1)</sup>		
Y	9	Bus output	Digital bus output, Y (Complementary to Z)
Z	10	Bus output	Digital bus output, Z (Complementary to Y)
B	11	Bus input	Digital bus input, B (Complementary to A)
A	12	Bus input	Digital bus input, A (Complementary to B)
V <sub>CC</sub>	13 <sup>(2)</sup>	Supply	3-V to 3.6-V supply
	14 <sup>(2)</sup>		

- (1) Pin 6 and pin 7 are connected internally.  
 (2) Pin 13 and pin 14 are connected internally.

## 7 Specifications

### 7.1 Absolute Maximum Ratings

over operating free-air temperature range (unless otherwise noted)<sup>(1)</sup>

		MIN	MAX	UNIT
Supply voltage	V <sub>CC</sub>	-0.5	5	V
Voltage	Range at any bus pin (A, B, Y, or Z)	-13	16.5	V
Input voltage	Range at any logic pin (D, DE, or $\overline{RE}$ )	-0.3	5.7	V
	Voltage input range, transient pulse, any bus pin (A, B, Y, or Z) through 100 $\Omega$	-100	100	V
Output current	Receiver output	-24	24	mA
Junction temperature, T <sub>J</sub>			170	°C
Storage temperature range, T <sub>stg</sub>		-65	150	°C
Continuous total power dissipation		See the <a href="#">Thermal Information</a> table		

(1) Stresses beyond those listed under *absolute maximum ratings* may cause permanent damage to the device. These are stress ratings only and functional operation of the device at these or any other conditions beyond those indicated under *recommended operating conditions* is not implied. Exposure to absolute-maximum-rated conditions for extended periods may affect device reliability.

### 7.2 ESD Ratings

			VALUE	UNIT
V <sub>(ESD)</sub>	Electrostatic discharge	Human body model (HBM), per JEDEC specification JESD22-A114, all pins	±8000	V
		Charged device model (CDM), per JEDEC specification JESD22-C101, all pins	±1500	V
		Machine model (MM), all pins	±300	V
		IEC 61000-4-2 ESD (Air-Gap Discharge), bus pins and GND <sup>(1)(2)</sup>	±12000	V
		IEC 61000-4-2 ESD (Contact Discharge), bus pins and GND	±12000	V
		IEC 61000-4-4 EFT (Fast transient or burst), bus pins and GND	±4000	V
		IEC 60749-26 ESD (Human Body Model), bus pins and GND <sup>(2)</sup>	±30000	V

(1) By inference from contact-discharge results, see the [Application and Implementation](#) section

(2) Limited by tester capability.

### 7.3 Recommended Operating Conditions

		MIN	NOM	MAX	UNIT
V <sub>CC</sub>	Supply voltage <sup>(1)</sup>	3	3.3	3.6	V
V <sub>I</sub>	Input voltage at any bus pin (separately or common mode) <sup>(2)</sup>	-7		12	V
V <sub>IH</sub>	High-level input voltage (Driver, driver enable, and receiver enable inputs)	2		V <sub>CC</sub>	V
V <sub>IL</sub>	Low-level input voltage (Driver, driver enable, and receiver enable inputs)	0		0.8	V
V <sub>ID</sub>	Differential input voltage	-12		12	V
I <sub>O</sub>	Output current, Driver	-60		60	mA
I <sub>O</sub>	Output current, Receiver	-8		8	mA
R <sub>L</sub>	Differential load resistance	54	60		$\Omega$
C <sub>L</sub>	Differential load capacitance		50		pF
1/t <sub>UI</sub>	Signaling rate	HVD70, HVD71		400	kbps
		HVD73, HVD74		20	Mbps
		HVD76, HVD77		50	
T <sub>A</sub> <sup>(3)</sup>	Operating free-air temperature (See the <a href="#">Application and Implementation</a> for thermal information)	-40		125	°C
T <sub>J</sub>	Junction Temperature	-40		150	°C

(1) Exposure to conditions beyond the recommended operation maximum for extended periods may affect device reliability.

(2) The algebraic convention, in which the least positive (most negative) limit is designated as minimum is used in this data sheet.

(3) Operation is specified for internal (junction) temperatures up to 150°C. Self-heating because of internal power dissipation should be considered for each application. Maximum junction temperature is internally limited by the thermal shut-down (TSD) circuit which disables the driver outputs when the junction temperature reaches 170°C.

## 7.4 Thermal Information — D Packages

THERMAL METRIC		D (8 PINS)	D (14 PINS)	Unit
$R_{\theta JA}$	Junction-to-ambient thermal resistance	110.7	83.3	°C/W
$R_{\theta JC(top)}$	Junction-to-case (top) thermal resistance	54.7	42.9	
$R_{\theta JB}$	Junction-to-board thermal resistance	51.3	37.8	
$\Psi_{JT}$	Junction-to-top characterization parameter	9.2	9.3	
$\Psi_{JB}$	Junction-to-board characterization parameter	50.7	37.5	
$T_{J(TSD)}$	Thermal shut-down junction temperature	170		°C

## 7.5 Thermal Information — DGS and DGK Packages

THERMAL METRIC		DGS (10 PINS)	DGK (8 PINS)	Unit
$R_{\theta JA}$	Junction-to-ambient thermal resistance	165.5	168.7	°C/W
$R_{\theta JC(top)}$	Junction-to-case (top) thermal resistance	37.7	62.2	
$R_{\theta JB}$	Junction-to-board thermal resistance	86.4	89.5	
$\Psi_{JT}$	Junction-to-top characterization parameter	1.4	7.4	
$\Psi_{JB}$	Junction-to-board characterization parameter	84.8	87.9	
$T_{J(TSD)}$	Thermal shut-down junction temperature	170		°C

## 7.6 Power Dissipation

PARAMETER		TEST CONDITIONS		VALUE	UNITS	
PD	Power Dissipation driver and receiver enabled, $V_{CC} = 3.6\text{ V}$ , $T_J = 150^\circ\text{C}$ 50% duty cycle square-wave signal at signaling rate: <ul style="list-style-type: none"> <li>HVD70 and HVD71 at 400 kbps</li> <li>HVD73 and HVD74 at 20 Mbps</li> <li>HVD76 and HVD77 at 50 Mbps</li> </ul>	Unterminated	$R_L = 300\ \Omega$ , $C_L = 50\ \text{pF}$ (driver)	HVD70, HVD71	150	mW
				HVD73, HVD74	180	
				HVD76, HVD77	220	
		RS-422 load	$R_L = 100\ \Omega$ , $C_L = 50\ \text{pF}$ (driver)	HVD70, HVD71	190	mW
				HVD73, HVD74	220	
				HVD76, HVD77	250	
		RS-485 load	$R_L = 54\ \Omega$ , $C_L = 50\ \text{pF}$ (driver)	HVD70, HVD71	230	mW
				HVD73, HVD74	255	
				HVD76, HVD77	285	

## 7.7 Electrical Characteristics

over recommended operating range (unless otherwise specified)

PARAMETER		TEST CONDITIONS		MIN	TYP	MAX	UNIT
$ V_{OD} $	Driver differential output voltage magnitude	$R_L = 60\ \Omega$ , 375 $\Omega$ on each output to $-7\text{ V}$ to $12\text{ V}$ , See <a href="#">15</a>		1.5	2		V
		$R_L = 54\ \Omega$ (RS-485), See <a href="#">16</a>		1.5	2		V
		$R_L = 100\ \Omega$ (RS-422) $T_J \geq 0^\circ\text{C}$ , $V_{CC} \geq 3.2\text{ V}$ , See <a href="#">16</a>		2			V
$\Delta V_{OD} $	Change in magnitude of driver differential output voltage	$R_L = 54\ \Omega$ , $C_L = 50\ \text{pF}$ , See <a href="#">16</a>		-50	0	50	mV
$V_{OC(SS)}$	Steady-state common-mode output voltage	Center of two 27- $\Omega$ load resistors, See <a href="#">16</a>		1	$V_{CC} / 2$	3	V
$\Delta V_{OC}$	Change in differential driver output common-mode voltage			-50	0	50	mV
$V_{OC(PP)}$	Peak-to-peak driver common-mode output voltage				500		mV
$C_{OD}$	Differential output capacitance				15		pF
$V_{IT+}$	Positive-going receiver differential input voltage threshold			See <sup>(1)</sup>	-70	-20	mV
$V_{IT-}$	Negative-going receiver differential input voltage threshold			-200	-140	See <sup>(1)</sup>	mV
$V_{hys}$	Receiver differential input voltage threshold hysteresis ( $V_{IT+} - V_{IT-}$ )			40	70		mV

(1) Under any specific conditions,  $V_{IT+}$  is assured to be at least  $V_{hys}$  higher than  $V_{IT-}$ .

## Electrical Characteristics (continued)

over recommended operating range (unless otherwise specified)

PARAMETER		TEST CONDITIONS		MIN	TYP	MAX	UNIT
V <sub>OH</sub>	Receiver high-level output voltage	I <sub>OH</sub> = -8 mA		2.4	V <sub>CC</sub> -0.3		V
V <sub>OL</sub>	Receiver low-level output voltage	I <sub>OL</sub> = 8 mA			0.2	0.4	V
I <sub>I</sub>	Driver input, driver enable, and receiver enable input current			-3		3	μA
I <sub>OZ</sub>	Receiver output high-impedance current	HVD70, HVD73, HVD76	V <sub>O</sub> = 0 V or V <sub>CC</sub> , $\overline{RE} = V_{CC}$	-1		1	μA
I <sub>OS</sub>	Driver short-circuit output current			-150		150	mA
I <sub>I</sub>	Bus input current (disabled driver)	V <sub>CC</sub> = 0 to ROC (max), DE = GND	HVD70, HVD73	V <sub>I</sub> = 12 V	75	125	μA
				V <sub>I</sub> = -7 V	-100	-40	
			HVD76	V <sub>I</sub> = 12 V	240	333	
				V <sub>I</sub> = -7 V	-267	-180	
I <sub>CC</sub>	Supply current (quiescent)	Driver and receiver enabled	DE = V <sub>CC</sub> , $\overline{RE} = GND$ , No load		750	1100	μA
		Driver enabled, receiver disabled	DE = V <sub>CC</sub> , $\overline{RE} = V_{CC}$ , No load		350	650	μA
		Driver disabled, receiver enabled	DE = GND, $\overline{RE} = GND$ , No load		650	800	μA
		Driver and receiver disabled	DE = GND, D = open, $\overline{RE} = V_{CC}$ , No load		0.1	5	μA
Supply current (dynamic)		See the <a href="#">Typical Characteristics</a> section					
T <sub>sd</sub>	Thermal Shut-down junction temperature					170	°C

## 7.8 Switching Characteristics — 400 kbps

400-kbps devices (SN65HVD70, SN65HVD71) bit time ≥ 2 μs (over recommended operating conditions)

PARAMETER		TEST CONDITIONS		MIN	TYP	MAX	UNIT
<b>DRIVER</b>							
t <sub>r</sub> , t <sub>f</sub>	Driver differential output rise/fall time	R <sub>L</sub> = 54 Ω, C <sub>L</sub> = 50 pF	See <a href="#">Figure 17</a>	100	400	750	ns
t <sub>PHL</sub> , t <sub>PLH</sub>	Driver propagation delay			350	550	ns	
t <sub>SK(P)</sub>	Driver pulse skew,  t <sub>PHL</sub> - t <sub>PLH</sub>			40	ns		
t <sub>PHZ</sub> , t <sub>PLZ</sub>	Driver disable time	HVD70	See <a href="#">Figure 18</a> and <a href="#">Figure 19</a>	50	200	ns	
t <sub>PZH</sub> , t <sub>PZL</sub>	Driver enable time			Receiver enabled	300	750	ns
				Receiver disabled	3	8	μs
<b>RECEIVER</b>							
t <sub>r</sub> , t <sub>f</sub>	Receiver output rise/fall time	C <sub>L</sub> = 15 pF	See <a href="#">Figure 20</a>	13	25	ns	
t <sub>PHL</sub> , t <sub>PLH</sub>	Receiver propagation delay time			70	110	ns	
t <sub>SK(P)</sub>	Receiver pulse skew,  t <sub>PHL</sub> - t <sub>PLH</sub>			7	ns		
t <sub>PLZ</sub> , t <sub>PHZ</sub>	Receiver disable time	HVD70	See <a href="#">Figure 21</a>	45	60	ns	
t <sub>PZL(1)</sub> , t <sub>PZH(1)</sub>	Receiver enable time			Driver enabled	20	115	ns
t <sub>PZL(2)</sub> , t <sub>PZH(2)</sub>				Driver disabled	See <a href="#">Figure 22</a>	3	8

## 7.9 Switching Characteristics — 20 Mbps

20-Mbps devices (SN65HVD73, SN65HVD74) bit time  $\geq 50$  ns (over recommended operating conditions)

PARAMETER		TEST CONDITIONS		MIN	TYP	MAX	UNIT
<b>DRIVER</b>							
$t_r, t_f$	Driver differential output rise/fall time	$R_L = 54 \Omega, C_L = 50 \text{ pF}$	See <a href="#">17</a>	4	7	14	ns
$t_{PHL}, t_{PLH}$	Driver propagation delay			4	10	20	ns
$t_{SK(P)}$	Driver pulse skew, $ t_{PHL} - t_{PLH} $			0	4	ns	
$t_{PHZ}, t_{PLZ}$	Driver disable time	HVD73	Receiver enabled	See <a href="#">18</a> and <a href="#">19</a>	12	25	ns
$t_{PZH}, t_{PZL}$	Driver enable time				10	20	ns
			Receiver disabled		3	8	$\mu\text{s}$
<b>RECEIVER</b>							
$t_r, t_f$	Receiver output rise/fall time	$C_L = 15 \text{ pF}$	See <a href="#">20</a>	5	10	ns	
$t_{PHL}, t_{PLH}$	Receiver propagation delay time			60	90	ns	
$t_{SK(P)}$	Receiver pulse skew, $ t_{PHL} - t_{PLH} $			0	5	ns	
$t_{PLZ}, t_{PHZ}$	Receiver disable time	HVD73	Driver enabled	See <a href="#">21</a>	17	25	ns
$t_{pZL(1)}, t_{pZH(1)}$ $t_{pZL(2)}, t_{pZH(2)}$	Receiver enable time				12	90	ns
			Driver disabled	See <a href="#">22</a>	3	8	$\mu\text{s}$

## 7.10 Switching Characteristics — 50 Mbps

50-Mbps devices (SN65HVD76, SN65HVD77) bit time  $\geq 20$  ns (over recommended operating conditions)

PARAMETER		TEST CONDITIONS		MIN	TYP	MAX	UNIT
<b>DRIVER</b>							
$t_r, t_f$	Driver differential output rise/fall time	$R_L = 54 \Omega, C_L = 50 \text{ pF}$	See <a href="#">17</a>	2	3	6	ns
$t_{PHL}, t_{PLH}$	Driver propagation delay			3	10	16	ns
$t_{SK(P)}$	Driver pulse skew, $ t_{PHL} - t_{PLH} $			0	3.5	ns	
$t_{PHZ}, t_{PLZ}$	Driver disable time	HVD76	Receiver enabled	See <a href="#">18</a> and <a href="#">19</a>	10	20	ns
$t_{PZH}, t_{PZL}$	Driver enable time				10	20	ns
			Receiver disabled		3	8	$\mu\text{s}$
<b>RECEIVER</b>							
$t_r, t_f$	Receiver output rise/fall time	$C_L = 15 \text{ pF}$	See <a href="#">20</a>	1	3	6	ns
$t_{PHL}, t_{PLH}$	Receiver propagation delay time			25	40	ns	
$t_{SK(P)}$	Receiver pulse skew, $ t_{PHL} - t_{PLH} $			0	2	ns	
$t_{PLZ}, t_{PHZ}$	Receiver disable time	HVD76	Driver enabled	See <a href="#">21</a>	8	15	ns
$t_{pZL(1)}, t_{pZH(1)}$ $t_{pZL(2)}, t_{pZH(2)}$	Receiver enable time				8	90	ns
			Driver disabled	See <a href="#">22</a>	3	8	$\mu\text{s}$

### 7.11 Typical Characteristics

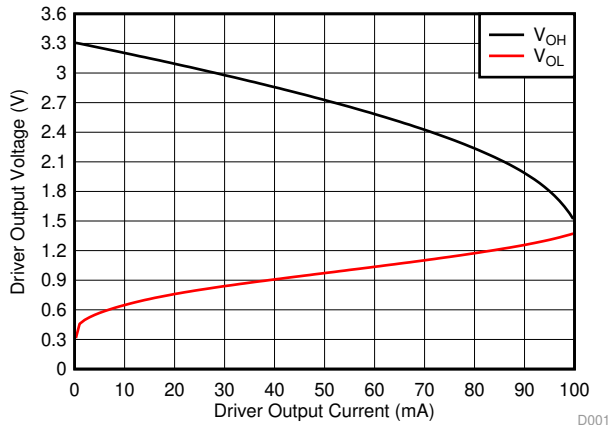

Fig 1. Driver Output Voltage vs Driver Output Current

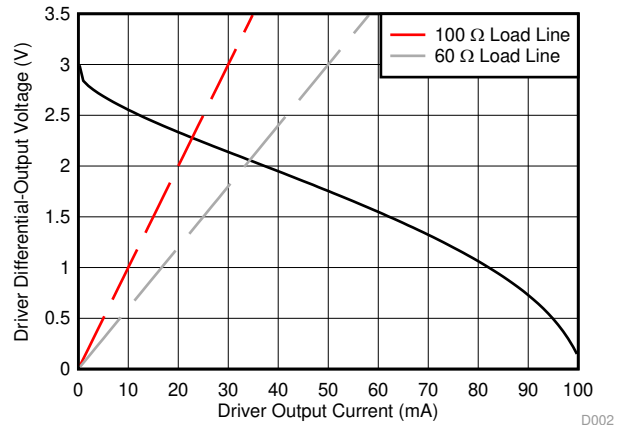

Fig 2. Driver Differential-Output Voltage vs Driver Output Current

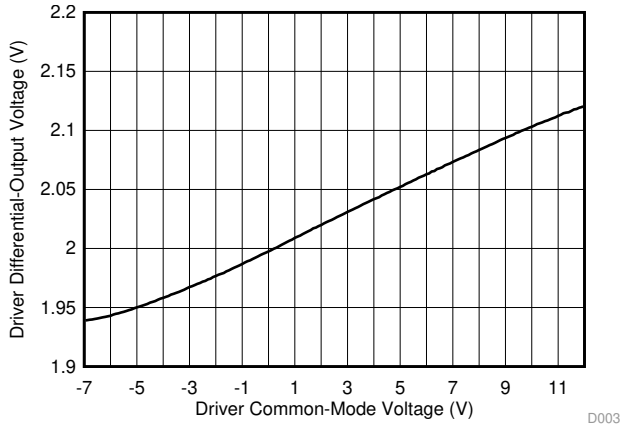

Fig 3. Driver Differential-Output Voltage vs Driver Common-Mode Voltage

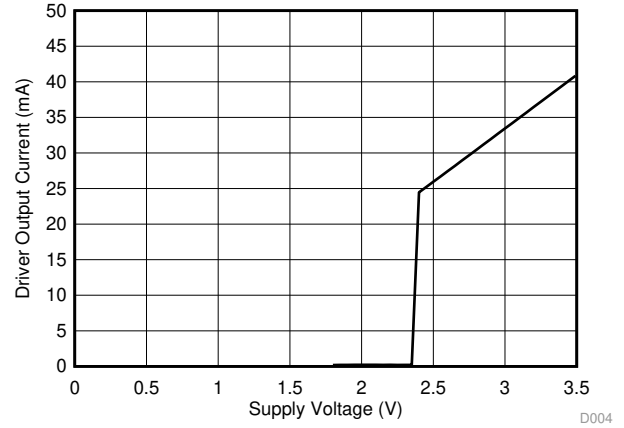

Fig 4. Driver Output Current vs Supply Voltage

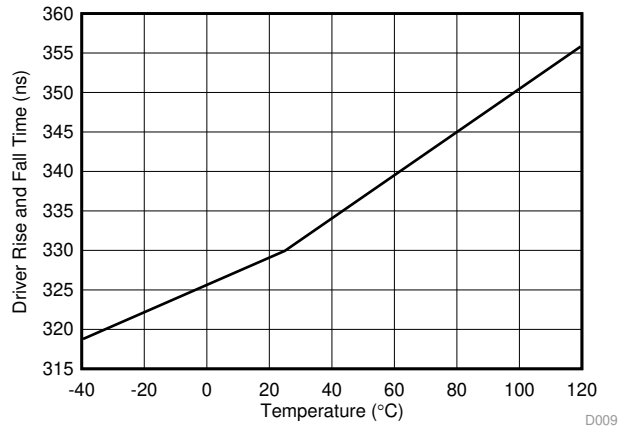

Fig 5. SN65HVD70, SN65HVD71 Driver Rise and Fall Time vs Temperature

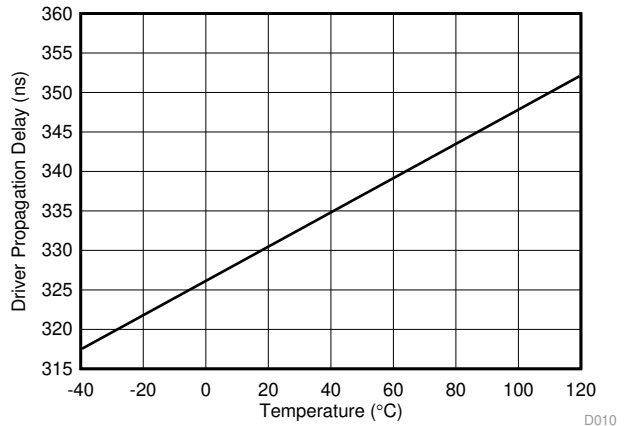

Fig 6. SN65HVD70, SN65HVD71 Driver Propagation Delay vs Temperature

**Typical Characteristics (continued)**

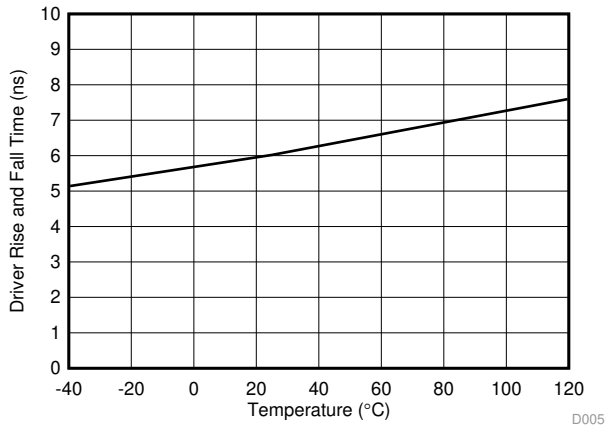

Fig 7. SN65HVD73, SN65HVD74 Driver Rise and Fall Time vs Temperature

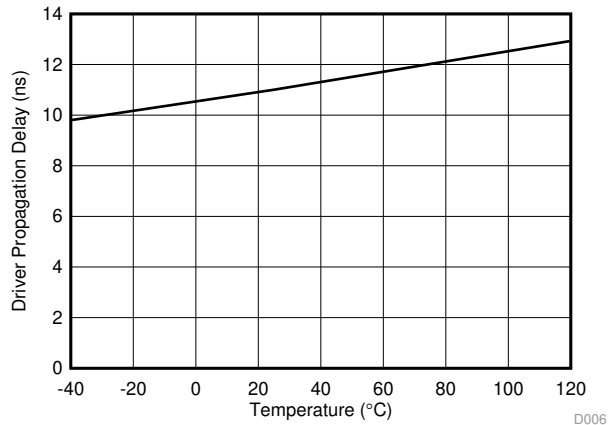

Fig 8. SN65HVD73, SN65HVD74 Driver Propagation Delay vs Temperature

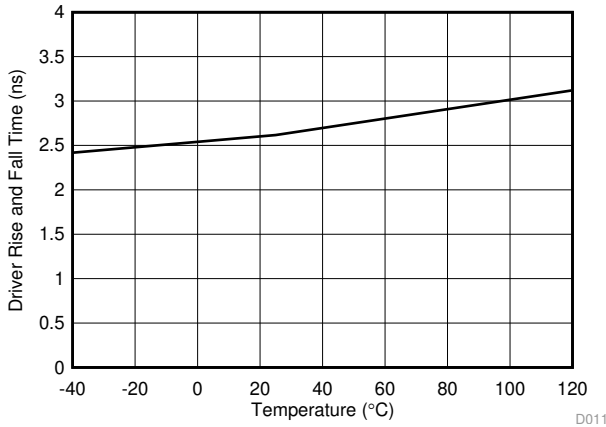

Fig 9. SN65HVD76, SN65HVD77 Driver Rise and Fall Time vs Temperature

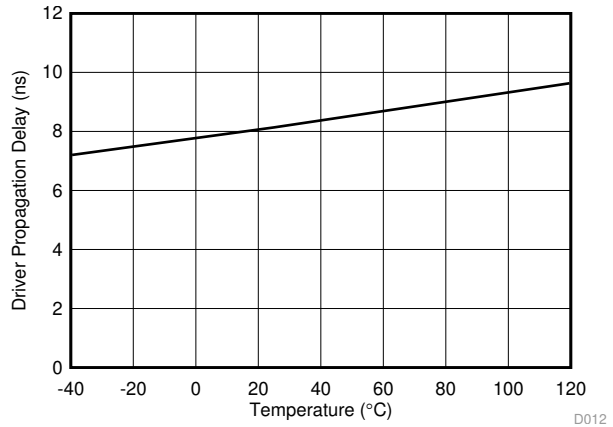

Fig 10. SN65HVD76, SN65HVD77 Driver Propagation Delay vs Temperature

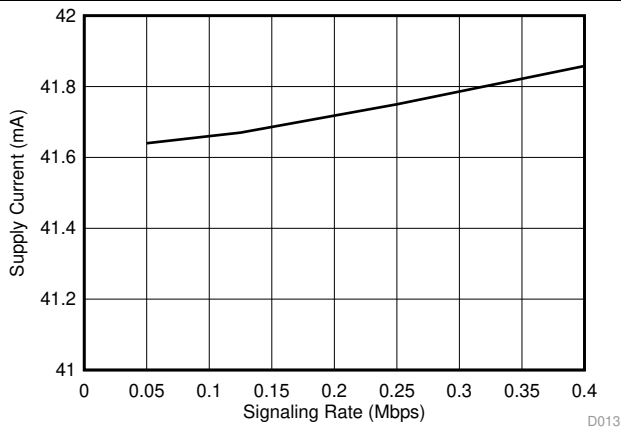

Fig 11. SN65HVD70, SN65HVD71 Supply Current vs Signal Rate

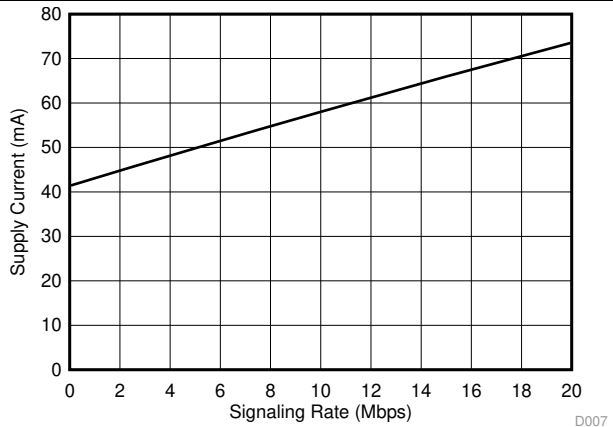
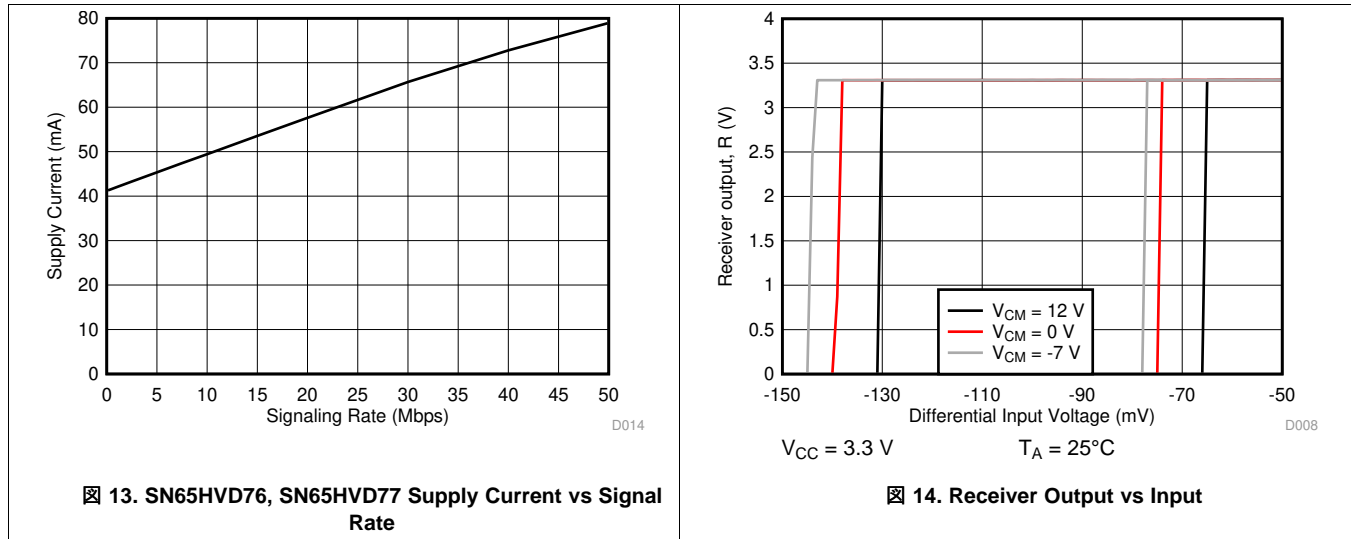

Fig 12. SN65HVD73, SN65HVD74 Supply Current vs Signal Rate

Typical Characteristics (continued)



8 Parameter Measurement Information

The input generator rate is 100 kbps with 50% duty cycle, than 6-ns rise and fall times, and 50-Ω output impedance.

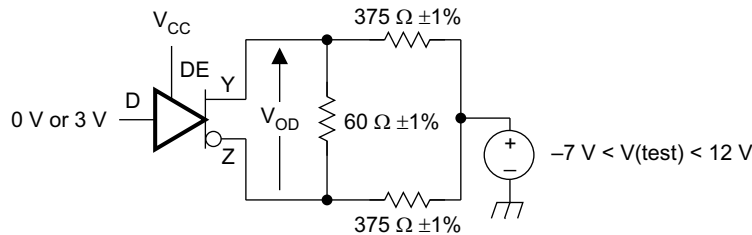

Figure 15. Measurement of Driver Differential Output Voltage With Common-Mode Load

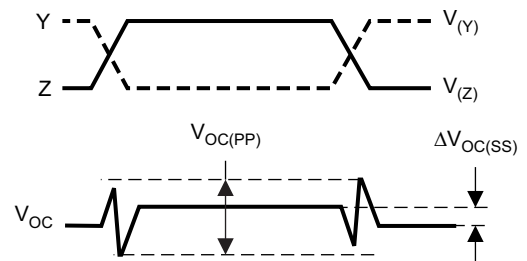
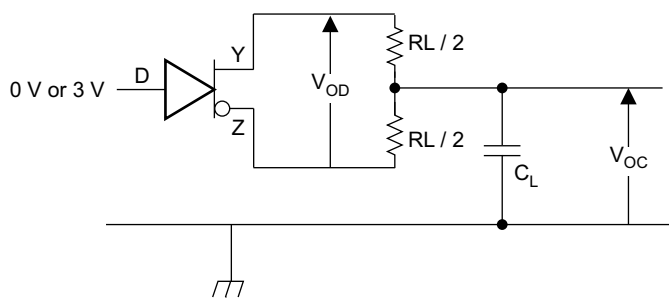

Figure 16. Measurement of Driver Differential and Common-Mode Output With RS-485 Load

Parameter Measurement Information (continued)

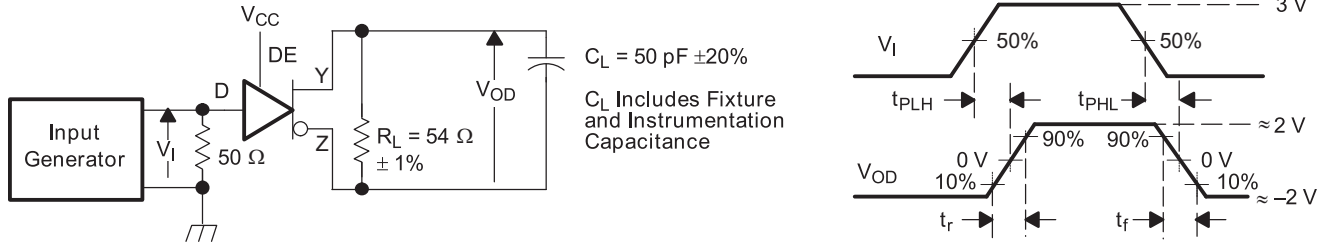
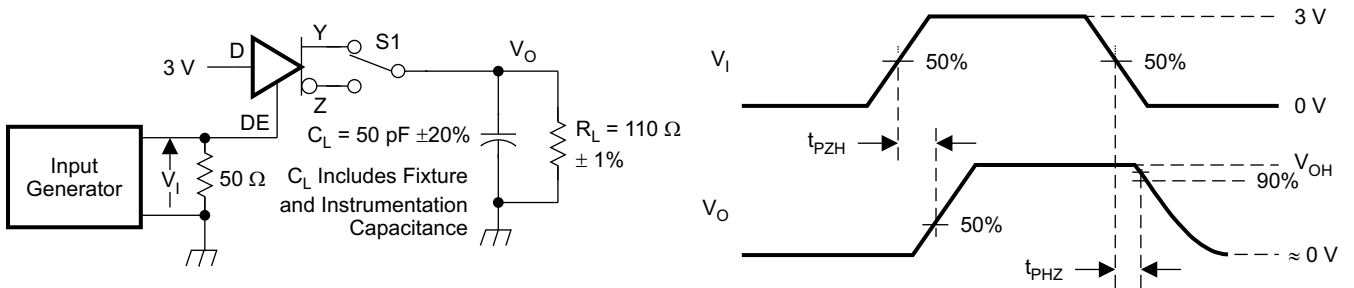
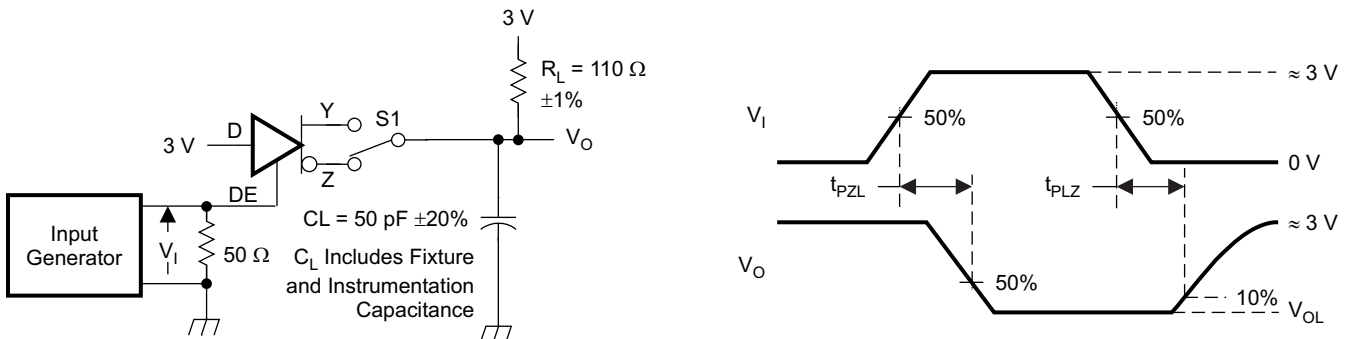

Figure 17. Measurement of Driver Differential Output Rise and Fall Times and Propagation Delays



D at 3 V to test non-inverting output, D at 0 V to test inverting output.

Figure 18. Measurement of Driver Enable and Disable Times with Active-High Output and Pulldown Load



D at 0 V to test non-inverting output, D at 3 V to test inverting output.

Figure 19. Measurement of Driver Enable and Disable Times with Active-Low Output and Pullup Load

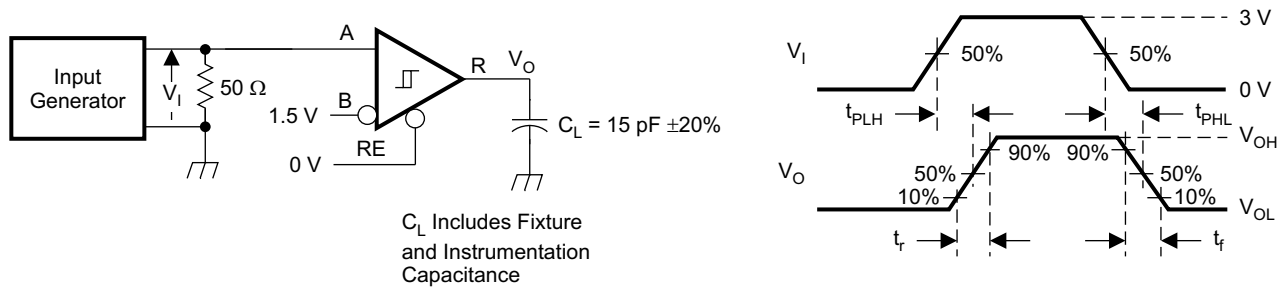
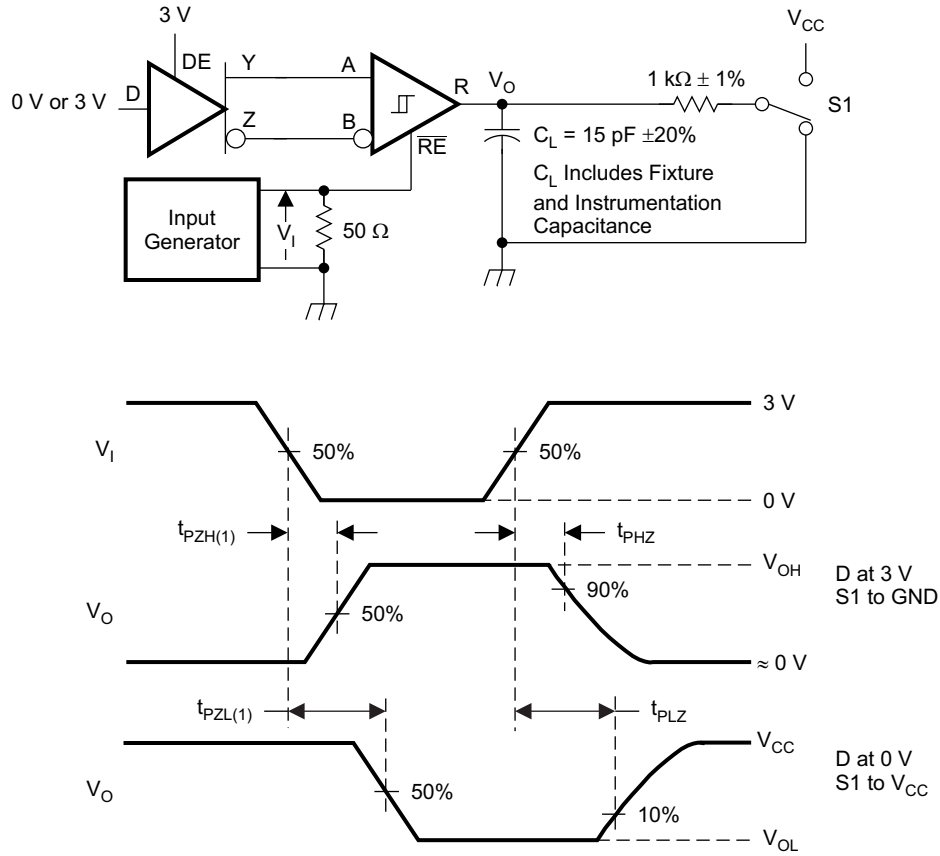

Figure 20. Measurement of Receiver Output Rise and Fall Times and Propagation Delays

Parameter Measurement Information (continued)



S0307-01

21. Measurement of Receiver Enable and Disable Times With Driver Enabled

**Parameter Measurement Information (continued)**

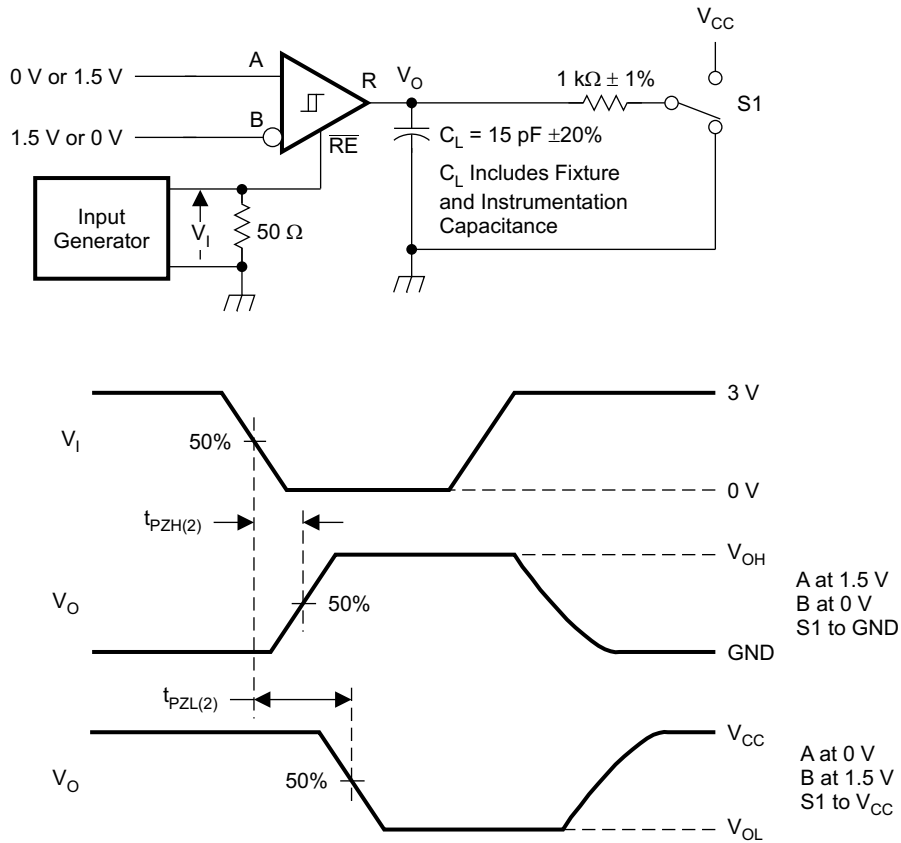

S0308-01

**22. Measurement of Receiver Enable Times With Driver Disabled**

## 9 Detailed Description

### 9.1 Overview

The SN65HVD70, SN65HVD71, SN65HVD73, SN65HVD74, SN65HVD76, and SN65HVD77 devices are low-power, full-duplex RS-485 transceivers available in three speed grades suitable for data transmission up to 400 kbps, 20 Mbps, and 50 Mbps.

The SN65HVD71, SN65HVD74, and SN65HVD77 are fully enabled with no external enabling pins. The SN65HVD70, SN65HVD73, and SN65HVD76 have active-high driver enables and active-low receiver enables. A standby current of less than 5  $\mu\text{A}$  can be achieved by disabling both driver and receiver.

### 9.2 Functional Block Diagram



图 23. Block Diagram  
SN65HVD70, SN65HVD73, and SN65HVD76



图 24. Block Diagram  
SN65HVD71, SN65HVD74, and SN65HVD77

### 9.3 Feature Description

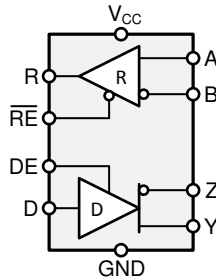
Internal ESD protection circuits protect the transceiver against Electrostatic Discharges (ESD) according to IEC61000-4-2 of up to  $\pm 12$  kV, and against electrical fast transients (EFT) according to IEC61000-4-4 of up to  $\pm 4$  kV.

The SN65HVD7x full-duplex family provides internal biasing of the receiver input thresholds in combination with large input-threshold hysteresis. At a positive input threshold of  $V_{IT+} = -20$  mV and an input hysteresis of  $V_{hys} = 40$  mV, the receiver output remains logic high under a bus-idle or bus-short condition even in the presence of 120 mV<sub>pp</sub> differential noise without the need for external failsafe biasing resistors.

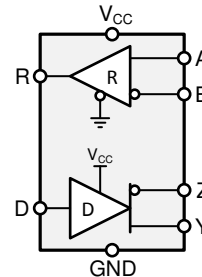
Device operation is specified over a wide temperature range from  $-40^{\circ}\text{C}$  to  $125^{\circ}\text{C}$ .

### 9.4 Device Functional Modes

For the SN65HVD70, SN65HVD73, and SN65HVD76, when the driver enable pin, DE, is logic high, the differential outputs Y and Z follow the logic states at data input D. A logic high at D causes Y to turn high and Z to turn low. In this case the differential output voltage defined as  $V_{OD} = V_{(Y)} - V_{(Z)}$  is positive. When D is low, the output states reverse, Z turns high, Y becomes low, and  $V_{OD}$  is negative.

When DE is low, both outputs turn high-impedance. In this condition the logic state at D is irrelevant. The DE pin has an internal pulldown resistor to ground, thus when left open the driver is disabled (high-impedance) by default. The D pin has an internal pullup resistor to  $V_{CC}$ , thus, when left open while the driver is enabled, output Y turns high and Z turns low.

表 1. Driver Function Table SN65HVD70, SN65HVD73, SN65HVD76

INPUT	ENABLE	OUTPUTS		FUNCTION
		Y	Z	
H	H	H	L	Actively drives the bus high
L	H	L	H	Actively drives the bus low
X	L	Z	Z	Driver disabled
X	OPEN	Z	Z	Driver disabled by default
OPEN	H	H	L	Actively drives the bus high by default

When the receiver enable pin,  $\overline{RE}$ , is logic low, the receiver is enabled. When the differential input voltage defined as  $V_{ID} = V_{(A)} - V_{(B)}$  is positive and higher than the positive input threshold,  $V_{IT+}$ , the receiver output, R, turns high. When  $V_{ID}$  is negative and less than the negative and lower than the negative input threshold,  $V_{IT-}$ , the receiver output, R, turns low. If  $V_{ID}$  is between  $V_{IT+}$  and  $V_{IT-}$  the output is indeterminate.

When  $\overline{RE}$  is logic high or left open, the receiver output is high-impedance and the magnitude and polarity of  $V_{ID}$  are irrelevant. Internal biasing of the receiver inputs causes the output to go failsafe-high when the transceiver is disconnected from the bus (open-circuit), the bus lines are shorted (short-circuit), or the bus is not actively driven (idle bus).

**表 2. Receiver Function Table SN65HVD70, SN65HVD73, SN65HVD76**

DIFFERENTIAL INPUT	ENABLE	OUTPUT	FUNCTION
$V_{ID} = V_{(A)} - V_{(B)}$	$\overline{RE}$	R	
$V_{IT+} < V_{ID}$	L	H	Receives valid bus High
$V_{IT-} < V_{ID} < V_{IT+}$	L	?	Indeterminate bus state
$V_{ID} < V_{IT-}$	L	L	Receives valid bus Low
X	H	Z	Receiver disabled
X	OPEN	Z	Receiver disabled by default
Open-circuit bus	L	H	Fail-safe high output
Short-circuit bus	L	H	Fail-safe high output
Idle (terminated) bus	L	H	Fail-safe high output

For the SN65HVD71, HVD74, and HVD77, the driver and receiver are fully enabled, thus the differential outputs Y and Z follow the logic states at data input D at all times. A logic high at D causes Y to turn high and Z to turn low. In this case the differential output voltage defined as  $V_{OD} = V_{(Y)} - V_{(Z)}$  is positive. When D is low, the output states reverse, Z turns high, Y becomes low, and  $V_{OD}$  is negative. The D pin has an internal pullup resistor to  $V_{CC}$ , thus, when left open while the driver is enabled, output Y turns high and Z turns low.

**表 3. Driver Function Table SN65HVD71, SN65HVD74, SN65HVD77**

INPUT	OUTPUTS		FUNCTION
D	Y	Z	
H	H	L	Actively drives the bus High
L	L	H	Actively drives the bus Low
OPEN	H	L	Actively drives the bus High by default

When the differential input voltage defined as  $V_{ID} = V_{(A)} - V_{(B)}$  is positive and higher than the positive input threshold,  $V_{IT+}$ , the receiver output, R, turns high. When  $V_{ID}$  is negative and less than the negative input threshold,  $V_{IT-}$ , the receiver output, R, turns low. If  $V_{ID}$  is between  $V_{IT+}$  and  $V_{IT-}$  the output is indeterminate. Internal biasing of the receiver inputs causes the output to go failsafe-high when the transceiver is disconnected from the bus (open-circuit), the bus lines are shorted (short-circuit), or the bus is not actively driven (idle bus).

**表 4. Receiver Function Table SN65HVD71, SN65HVD74, SN65HVD77**

DIFFERENTIAL INPUT	OUTPUT	FUNCTION
$V_{ID} = V_{(A)} - V_{(B)}$	R	
$V_{IT+} < V_{ID}$	H	Receives valid bus High
$V_{IT-} < V_{ID} < V_{IT+}$	?	Indeterminate bus state
$V_{ID} < V_{IT-}$	L	Receives valid bus Low
Open-circuit bus	H	Fail-safe high output
Short-circuit bus	H	Fail-safe high output
Idle (terminated) bus	H	Fail-safe high output

**9.4.1 Equivalent Circuits**

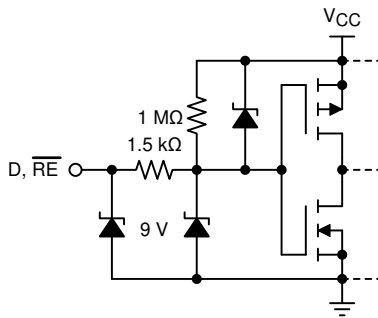

**Figure 25. D and  $\overline{RE}$  Inputs**

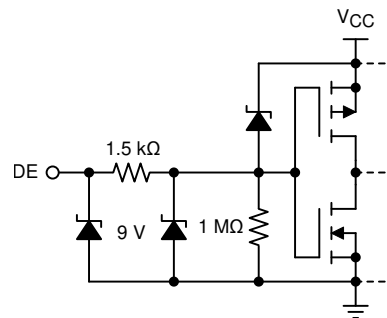

**Figure 26. DE Input**

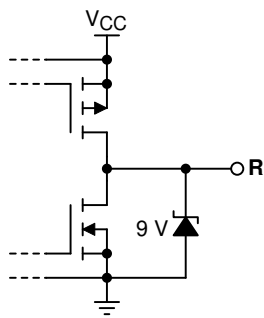

**Figure 27. R Output**

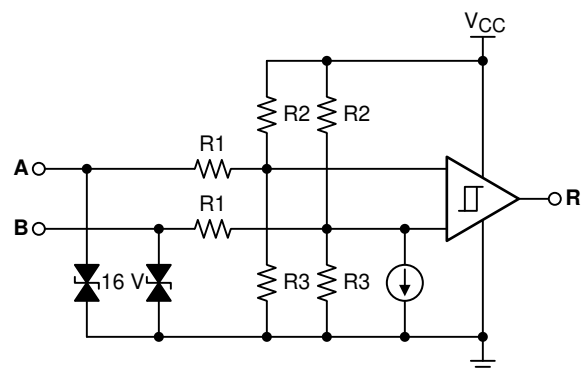

**Figure 28. Receiver Inputs**

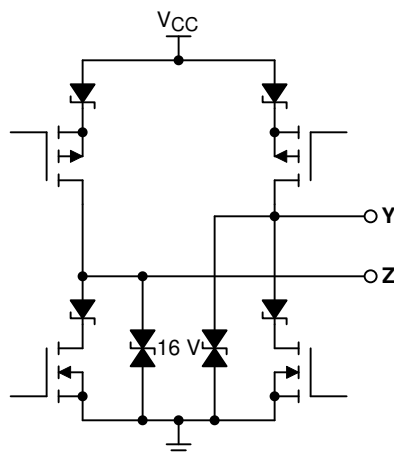

**Figure 29. Driver Outputs**

## 10 Application and Implementation

### 注

Information in the following applications sections is not part of the TI component specification, and TI does not warrant its accuracy or completeness. TI's customers are responsible for determining suitability of components for their purposes. Customers should validate and test their design implementation to confirm system functionality.

### 10.1 Application Information

The SN65HVD7x family consists of full-duplex RS-485 transceivers commonly used for asynchronous data transmissions. Full-duplex implementation requires two signal pairs (four wires), and allows each node to transmit data on one pair while simultaneously receiving data on the other pair.

To eliminate line reflections, each cable end is terminated with a termination resistor,  $R_{(T)}$ , whose value matches the characteristic impedance,  $Z_0$ , of the cable. This method, known as parallel termination, allows for higher data rates over longer cable length.



图 30. Typical RS-485 Network With SN65HVD7x Full-Duplex Transceivers

### 10.2 Typical Application

A full-duplex RS-485 network consists of multiple transceivers connecting in parallel to two bus cables. On one signal pair, a master driver transmits data to multiple slave receivers. The master driver and slave receivers may remain fully enabled at all times. On the other signal pair, multiple slave drivers transmit data to the master receiver. To avoid bus contention, the slave drivers must be intermittently enabled and disabled such that only one driver is enabled at any time, as in half-duplex communication. The master receiver may remain fully enabled at all times.

Because the driver may not be disabled, only one driver should be connected to the bus when using the SN65HVD71, SN65HVD74, or SN65HVD77 device.

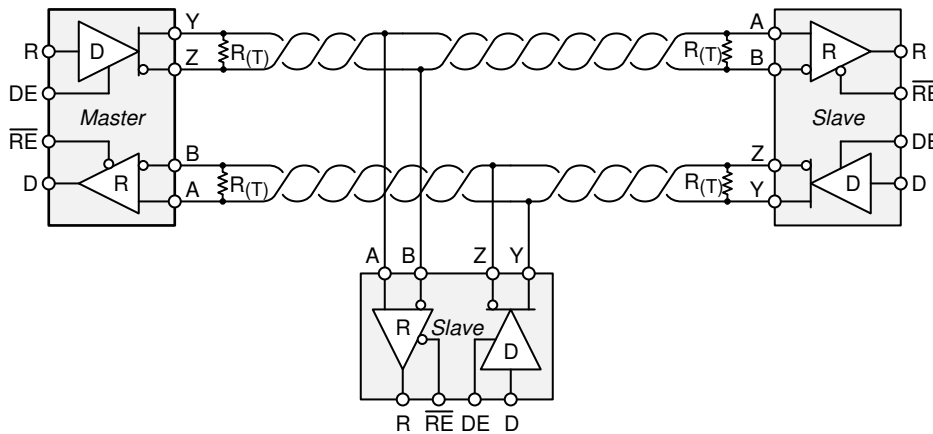

图 31. Full-Duplex Transceiver Configurations

## Typical Application (continued)

### 10.2.1 Design Parameters

RS-485 is a robust electrical standard suitable for long-distance networking that may be used in a wide range of applications with varying requirements, such as distance, data rate, and number of nodes.

#### 10.2.1.1 Data Rate and Bus Length

There is an inverse relationship between data rate and cable length, which means the higher the data rate, the shorter the cable length; and conversely, the lower the data rate, the longer the cable length. While most RS-485 systems use data rates between 10 kbps and 100 kbps, some applications require data rates up to 250 kbps at distances of 4000 ft and longer. Longer distances are possible by allowing for small signal jitter of up to 5 or 10%.



图 32. Cable Length vs Data Rate Characteristic

#### 10.2.1.2 Stub Length

When connecting a node to the bus, the distance between the transceiver inputs and the cable trunk, known as the stub, should be as short as possible. Stubs present a non-terminated piece of bus line which can introduce reflections as the length of the stub increases. As a general guideline, the electrical length, or round-trip delay, of a stub should be less than one-tenth of the rise time of the driver, thus giving a maximum physical stub length as shown in 式 1.

$$L_{(\text{STUB})} \leq 0.1 \times t_r \times v \times c$$

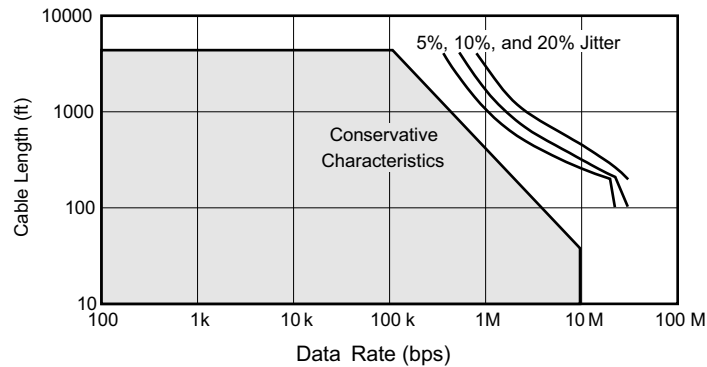
where

- $t_r$  is the 10/90 rise time of the driver
- $v$  is the signal velocity of the cable or trace as a factor of  $c$
- $c$  is the speed of light ( $3 \times 10^8$  m/s)

(1)

Per 式 1, 表 5 lists the maximum cable-stub lengths for the minimum-driver output rise-times of the SN65HVD7x full-duplex family of transceivers for a signal velocity of 78%.

表 5. Maximum Stub Length

DEVICE	MINIMUM DRIVER OUTPUT RISE TIME (ns)	MAXIMUM STUB LENGTH	
		(m)	(ft)
SN65HVD70	100	2.34	7.7
SN65HVD71	100	2.34	7.7
SN65HVD73	4	0.1	0.3
SN65HVD74	4	0.1	0.3
SN65HVD76	2	0.05	0.15
SN65HVD77	2	0.05	0.15

### 10.2.1.3 Bus Loading

The RS-485 standard specifies that a compliant driver must be able to driver 32 unit loads (UL), where 1 unit load represents a load impedance of approximately 12 kΩ. Because the SN65HVD7x family consists of 1/8 UL transceivers, connecting up to 256 receivers to the bus is possible.

### 10.2.1.4 Receiver Failsafe

The differential receivers of the SN65HVD7x family are *failsafe* to invalid bus states caused by the following:

- Open bus conditions, such as a disconnected connector
- Shorted bus conditions, such as cable damage shorting the twisted-pair together
- Idle bus conditions that occur when no driver on the bus is actively driving

In any of these cases, the differential receiver will output a failsafe logic high state so that the output of the receiver is not indeterminate.

Receiver failsafe is accomplished by offsetting the receiver thresholds such that the *input indeterminate* range does not include zero volts differential. In order to comply with the RS-422 and RS-485 standards, the receiver output must output a high when the differential input  $V_{ID}$  is more positive than 200 mV, and must output a Low when  $V_{ID}$  is more negative than –200 mV. The receiver parameters which determine the failsafe performance are  $V_{IT+}$ ,  $V_{IT-}$ , and  $V_{hys}$  (the separation between  $V_{IT+}$  and  $V_{IT-}$ ). As shown in the [Electrical Characteristics](#) table, differential signals more negative than –200 mV will always cause a low receiver output, and differential signals more positive than 200 mV will always cause a high receiver output.

When the differential input signal is close to zero, it is still above the  $V_{IT+}$  threshold, and the receiver output will be High. Only when the differential input is more than  $V_{hys}$  below  $V_{IT+}$  will the receiver output transition to a Low state. Therefore, the noise immunity of the receiver inputs during a bus fault conditions includes the receiver hysteresis value,  $V_{hys}$ , as well as the value of  $V_{IT+}$ .

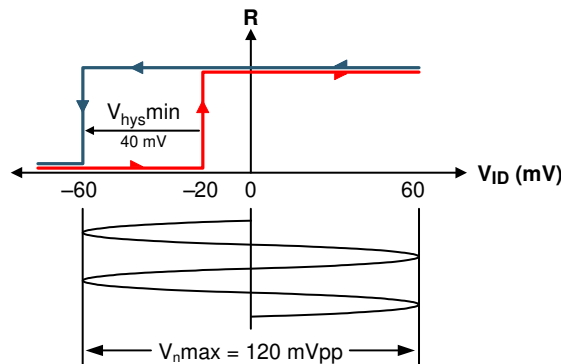
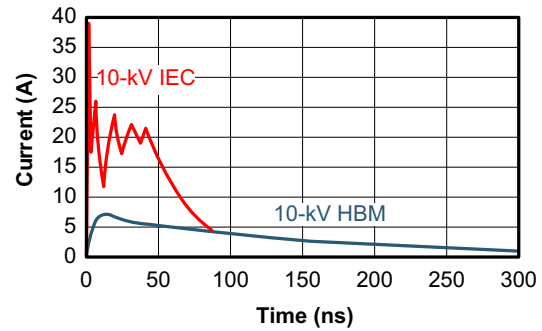
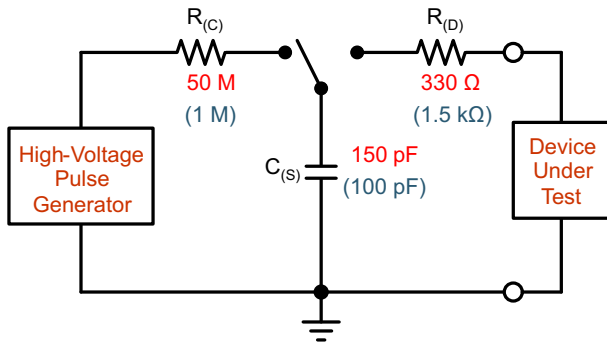

FIG 33. SN65HVD7x Noise Immunity Under Bus Fault Conditions

### 10.2.1.5 Transient Protection

The bus pins of the SN65HVD7x full-duplex transceiver family include on-chip ESD protection against  $\pm 30$ -kV HBM and  $\pm 12$ -kV IEC 61000-4-2 contact discharge. The International Electrotechnical Commission (IEC) ESD test is far more severe than the HBM ESD test. The 50% higher charge capacitance,  $C_{(S)}$ , and 78% lower discharge resistance,  $R_{(D)}$ , of the IEC model produce significantly higher discharge currents than the HBM model.

As stated in the IEC 61000-4-2 standard, contact discharge is the preferred transient protection test method. Although IEC air-gap testing is less repeatable than contact testing, air discharge protection levels are inferred from contact discharge test results.



34. HBM and IEC ESD Models and Currents in Comparison (HBM Values in Parenthesis)

The on-chip implementation of IEC ESD protection significantly increases the robustness of equipment. Common discharge events occur because of human contact with connectors and cables. Designers may choose to implement protection against longer duration transients, typically referred to as surge transients.

EFTs are generally caused by relay-contact bounce or the interruption of inductive loads. Surge transients often result from lightning strikes (direct strike or an indirect strike which induce voltages and currents), or the switching of power systems, including load changes and short circuit switching. These transients are often encountered in industrial environments, such as factory automation and power-grid systems.

35 compares the pulse-power of the EFT and surge transients with the power caused by an IEC ESD transient. The left hand diagram shows the relative pulse-power for a 0.5kV surge transient and 4-kV EFT transient, both of which dwarf the 10-kV ESD transient visible in the lower-left corner. 500-V surge transients are representative of events that may occur in factory environments in industrial and process automations.

The right hand diagram shows the pulse-power of a 6-kV surge transient, relative to the same 0.5-kV surge transient. 6-kV surge transients are most likely to occur in power generation and power-grid systems.

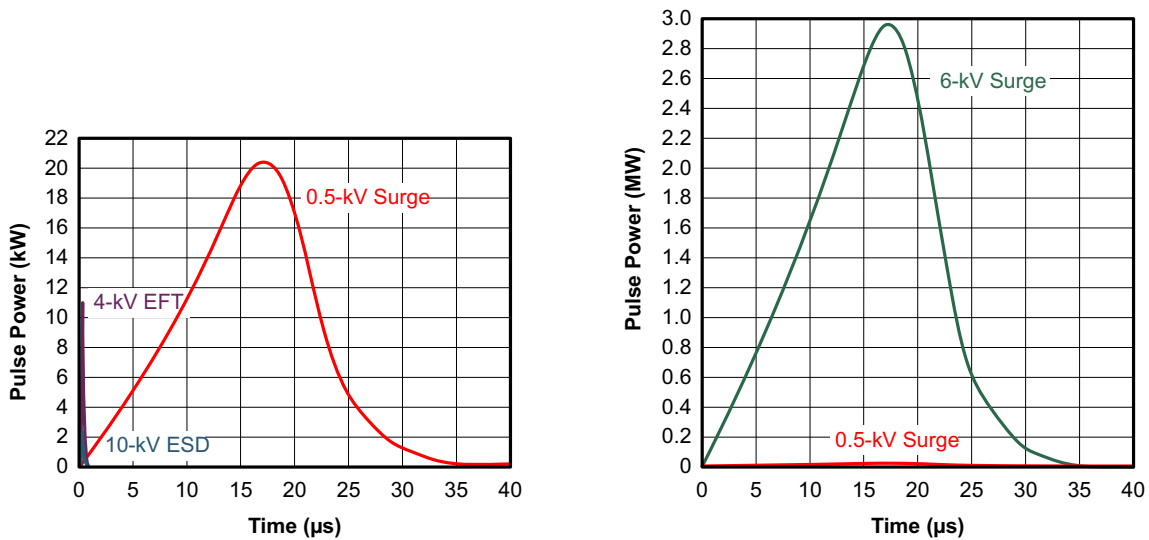

35. Power Comparison of ESD, EFT, and Surge Transients

In the case of surge transients, high-energy content is characterized by long pulse duration and slow decaying pulse power. The electrical energy of a transient that is dumped into the internal protection cells of a transceiver is converted into thermal energy, which heats and destroys the protection cells, thus destroying the transceiver.

36 shows the large differences in transient energies for single ESD, EFT, surge transients, and an EFT pulse train that is commonly applied during compliance testing.

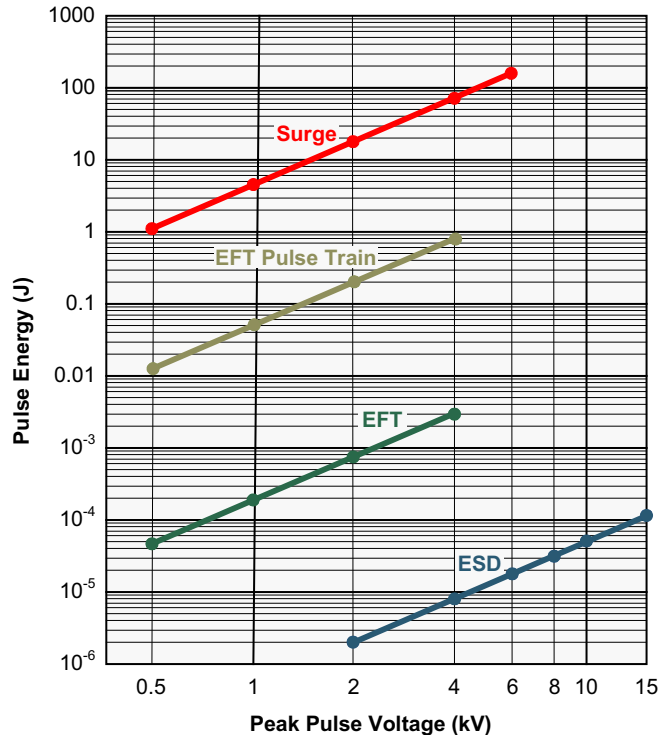

Figure 36. Comparison of Transient Energies

### 10.2.2 Detailed Design Procedure

In order to protect bus nodes against high-energy transients, the implementation of external transient protection devices is therefore necessary. Figure 37 shows a protection circuit against 16-kV ESD, 4-kV EFT, and 1-kV surge transients.

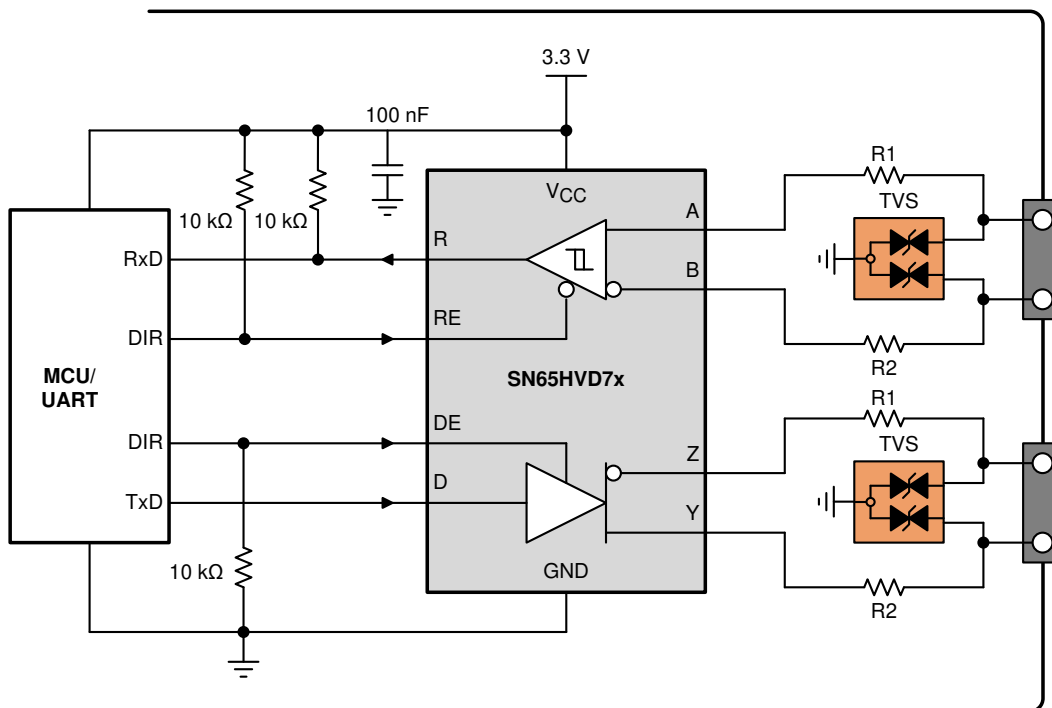
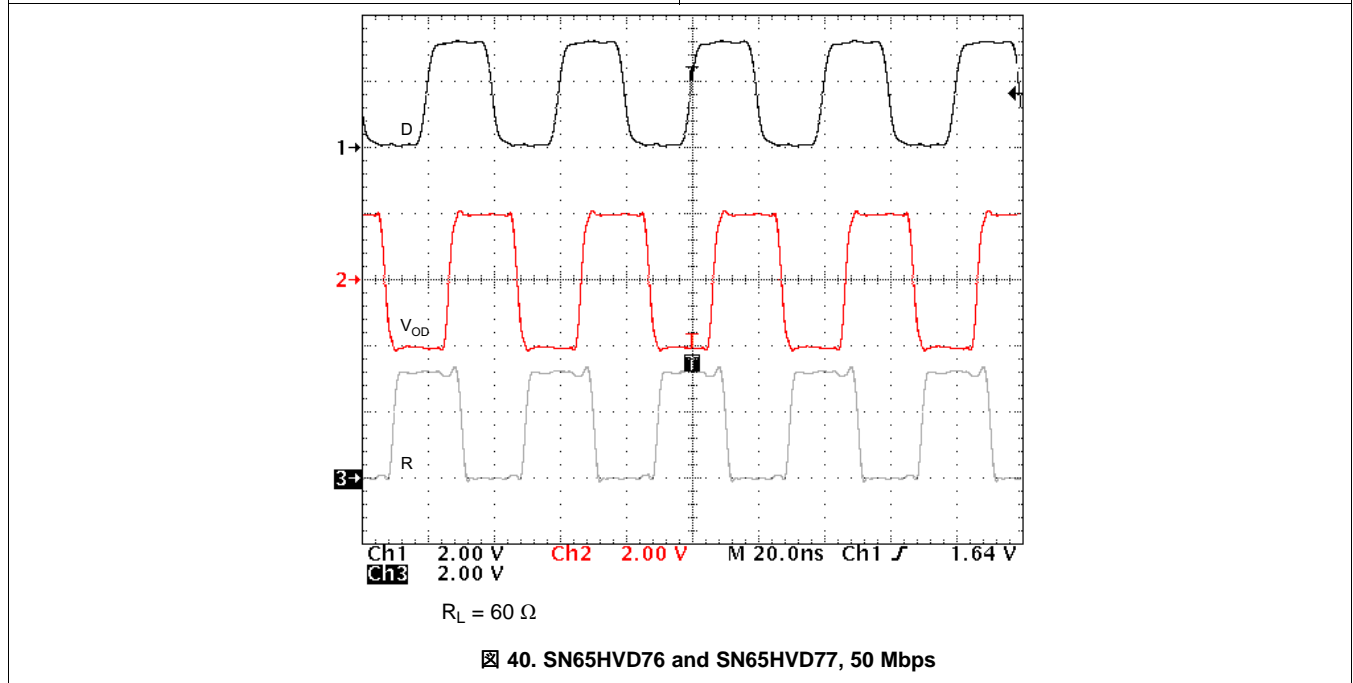
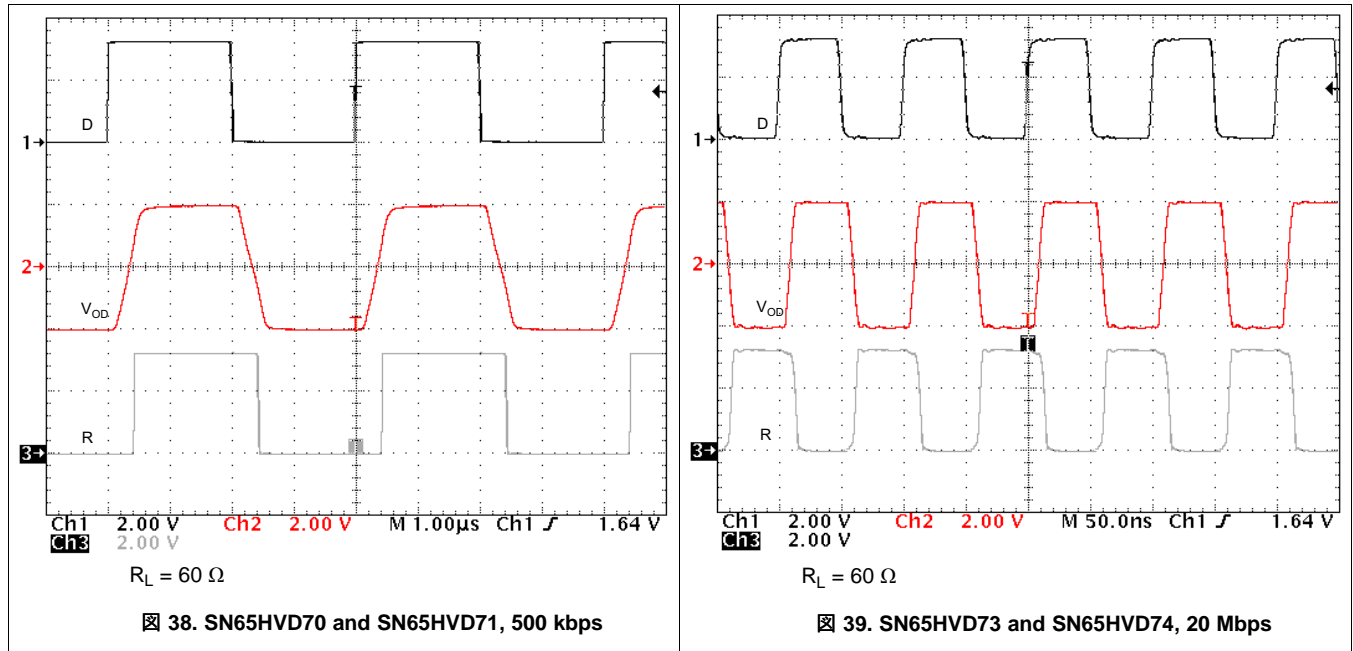

Figure 37. Transient Protection Against ESD, EFT, and Surge transients

表 6. Bill of Materials

DEVICE	FUNCTION	ORDER NUMBER	MANUFACTURER
XCVR	3.3-V, full-duplex RS-485 transceiver	SN65HVD7xD	TI
R1 R2	10-Ω, pulse-proof thick-film resistor	CRCW0603010RJNEAHP	Vishay
TVS	Bidirectional 400-W transient suppressor	CDSOT23-SM712	Bourns

10.2.3 Application Curves



## 11 Power Supply Recommendations

To ensure reliable operation at all data rates and supply voltages, each supply should be buffered with a 100-nF ceramic capacitor located as close to the supply pins as possible. The TPS76333 is a linear voltage regulator suitable for the 3.3-V supply.

## 12 Layout

### 12.1 Layout Guidelines

On-chip IEC-ESD protection is good for laboratory and portable equipment but never sufficient for EFT and surge transients occurring in industrial environments. Therefore robust and reliable bus node design requires the use of external transient protection devices.

Because ESD and EFT transients have a wide frequency bandwidth from approximately 3-MHz to 3-GHz, high-frequency layout techniques must be applied during PCB design.

For successful PCB design, begin with the design of the protection circuit (see [Figure 41](#)).

1. Place the protection circuitry close to the bus connector to prevent noise transients from penetrating your board.
2. Use  $V_{CC}$  and ground planes to provide low-inductance. Note that high-frequency currents follow the path of least inductance and not the path of least impedance.
3. Design the protection components into the direction of the signal path. Do not force the transient currents to divert from the signal path to reach the protection device.
4. Apply 100-nF to 220-nF bypass capacitors as close as possible to the  $V_{CC}$ -pins of transceiver, UART, controller ICs on the board (see [Figure 41](#)).
5. Use at least two vias for  $V_{CC}$  and ground connections of bypass capacitors and protection devices to minimize effective via-inductance (see [Figure 41](#)).
6. Use 1-k $\Omega$  to 10-k $\Omega$  pullup and pulldown resistors for enable lines to limit noise currents in these lines during transient events (see [Figure 41](#)).
7. Insert pulse-proof resistors into the A and B bus lines if the TVS clamping voltage is higher than the specified maximum voltage of the transceiver bus pins. These resistors limit the residual clamping current into the transceiver and prevent it from latching up (see [Figure 41](#)).
8. While pure TVS protection is sufficient for surge transients up to 1 kV, higher transients require metal-oxide varistors (MOVs) which reduce the transients to a few hundred volts of clamping voltage, and transient blocking units (TBUs) that limit transient current to less than 1 mA.

## 12.2 Layout Example

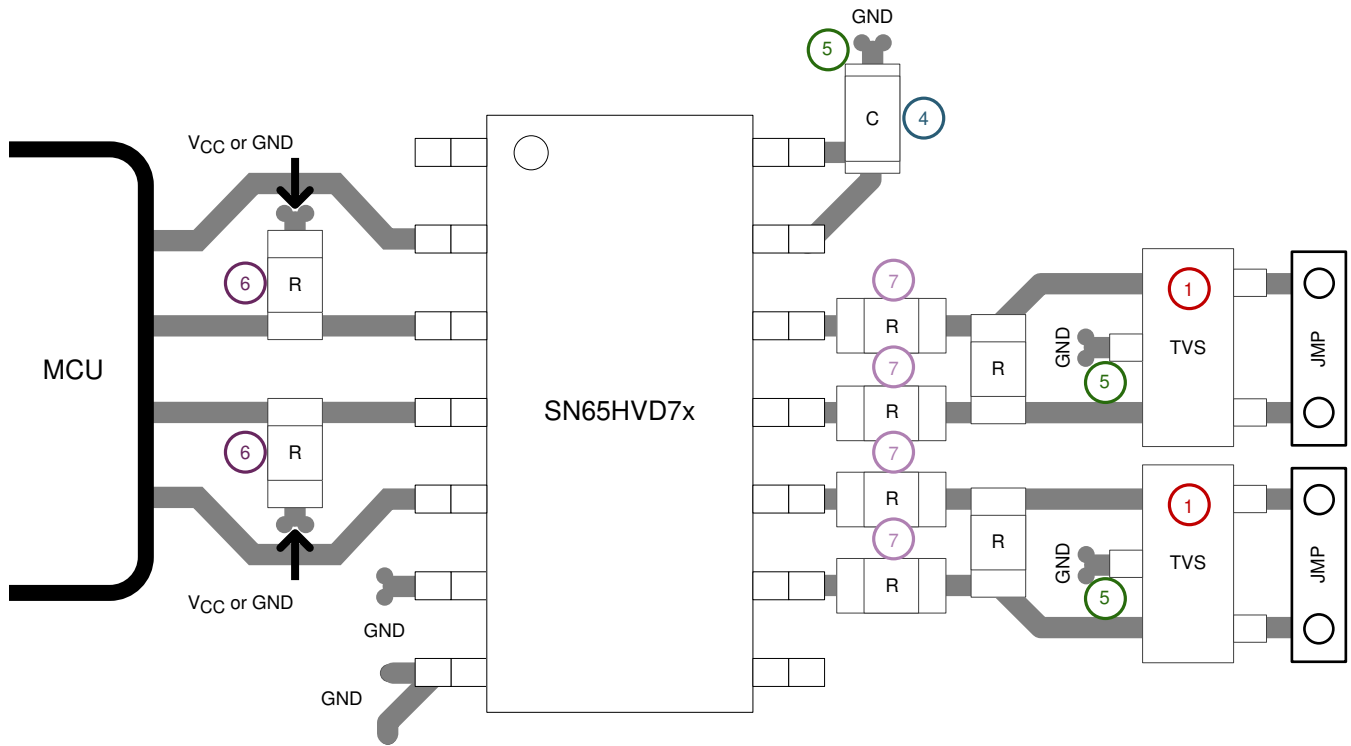

41. SN65HVD7x Layout Example

## 13 デバイスおよびドキュメントのサポート

### 13.1 デバイス・サポート

#### 13.1.1 デベロッパー・ネットワークの製品に関する免責事項

デベロッパー・ネットワークの製品またはサービスに関するTIの出版物は、単独またはTIの製品、サービスと一緒に提供される場合に関係なく、デベロッパー・ネットワークの製品またはサービスの適合性に関する是認、デベロッパー・ネットワークの製品またはサービスの是認の表明を意味するものではありません。

### 13.2 関連リンク

次の表に、クイック・アクセス・リンクを示します。カテゴリには、技術資料、サポートおよびコミュニティ・リソース、ツールとソフトウェア、およびサンプル注文またはご購入へのクイック・アクセスが含まれます。

表 7. 関連リンク

製品	プロダクト・フォルダ	サンプルとご購入	技術資料	ツールとソフトウェア	サポートとコミュニティ
SN65HVD70	<a href="#">ここをクリック</a>	<a href="#">ここをクリック</a>	<a href="#">ここをクリック</a>	<a href="#">ここをクリック</a>	<a href="#">ここをクリック</a>
SN65HVD71	<a href="#">ここをクリック</a>	<a href="#">ここをクリック</a>	<a href="#">ここをクリック</a>	<a href="#">ここをクリック</a>	<a href="#">ここをクリック</a>
SN65HVD73	<a href="#">ここをクリック</a>	<a href="#">ここをクリック</a>	<a href="#">ここをクリック</a>	<a href="#">ここをクリック</a>	<a href="#">ここをクリック</a>
SN65HVD74	<a href="#">ここをクリック</a>	<a href="#">ここをクリック</a>	<a href="#">ここをクリック</a>	<a href="#">ここをクリック</a>	<a href="#">ここをクリック</a>
SN65HVD76	<a href="#">ここをクリック</a>	<a href="#">ここをクリック</a>	<a href="#">ここをクリック</a>	<a href="#">ここをクリック</a>	<a href="#">ここをクリック</a>
SN65HVD77	<a href="#">ここをクリック</a>	<a href="#">ここをクリック</a>	<a href="#">ここをクリック</a>	<a href="#">ここをクリック</a>	<a href="#">ここをクリック</a>

### 13.3 ドキュメントの更新通知を受け取る方法

ドキュメントの更新についての通知を受け取るには、[ti.com](#)のデバイス製品フォルダを開いてください。右上の「アラートを受け取る」をクリックして登録すると、変更されたすべての製品情報に関するダイジェストを毎週受け取れます。変更の詳細については、修正されたドキュメントに含まれている改訂履歴をご覧ください。

### 13.4 コミュニティ・リソース

[TI E2E™ support forums](#) are an engineer's go-to source for fast, verified answers and design help — straight from the experts. Search existing answers or ask your own question to get the quick design help you need.

Linked content is provided "AS IS" by the respective contributors. They do not constitute TI specifications and do not necessarily reflect TI's views; see TI's [Terms of Use](#).

### 13.5 商標

E2E is a trademark of Texas Instruments.

All other trademarks are the property of their respective owners.

### 13.6 静電気放電に関する注意事項



すべての集積回路は、適切なESD保護方法を用いて、取扱いと保存を行うようにして下さい。

静電気放電はわずかな性能の低下から完全なデバイスの故障に至るまで、様々な損傷を与えます。高精度の集積回路は、損傷に対して敏感であり、極めてわずかなパラメータの変化により、デバイスに規定された仕様に適合しなくなる場合があります。

### 13.7 Glossary

[SLYZ022](#) — *TI Glossary*.

This glossary lists and explains terms, acronyms, and definitions.

## 14 メカニカル、パッケージ、および注文情報

以降のページには、メカニカル、パッケージ、および注文に関する情報が記載されています。これらの情報は、指定のデバイスに対して提供されている最新のデータです。このデータは予告なく変更されることがあり、ドキュメントが改訂される場合もあります。本データシートのブラウザ版を使用されている場合は、画面左側の説明をご覧ください。

**PACKAGING INFORMATION**

Orderable part number	Status (1)	Material type (2)	Package   Pins	Package qty   Carrier	RoHS (3)	Lead finish/ Ball material (4)	MSL rating/ Peak reflow (5)	Op temp (°C)	Part marking (6)
<a href="#">SN65HVD70D</a>	Active	Production	SOIC (D)   14	50   TUBE	Yes	NIPDAU	Level-2-260C-1 YEAR	-40 to 125	HVD70
SN65HVD70D.B	Active	Production	SOIC (D)   14	50   TUBE	Yes	NIPDAU	Level-2-260C-1 YEAR	-40 to 125	HVD70
<a href="#">SN65HVD70DGS</a>	Active	Production	VSSOP (DGS)   10	80   TUBE	Yes	NIPDAUAG	Level-2-260C-1 YEAR	-40 to 125	VD70
SN65HVD70DGS.B	Active	Production	VSSOP (DGS)   10	80   TUBE	Yes	NIPDAUAG	Level-2-260C-1 YEAR	-40 to 125	VD70
<a href="#">SN65HVD70DGSR</a>	Active	Production	VSSOP (DGS)   10	2500   LARGE T&R	Yes	NIPDAUAG	Level-1-260C-UNLIM	-40 to 125	VD70
SN65HVD70DGSR.B	Active	Production	VSSOP (DGS)   10	2500   LARGE T&R	Yes	NIPDAUAG	Level-1-260C-UNLIM	-40 to 125	VD70
<a href="#">SN65HVD70DR</a>	Active	Production	SOIC (D)   14	2500   LARGE T&R	Yes	NIPDAU	Level-2-260C-1 YEAR	-40 to 125	HVD70
SN65HVD70DR.B	Active	Production	SOIC (D)   14	2500   LARGE T&R	Yes	NIPDAU	Level-2-260C-1 YEAR	-40 to 125	HVD70
SN65HVD70DRG4	Active	Production	SOIC (D)   14	2500   LARGE T&R	Yes	NIPDAU	Level-2-260C-1 YEAR	-40 to 125	HVD70
SN65HVD70DRG4.B	Active	Production	SOIC (D)   14	2500   LARGE T&R	Yes	NIPDAU	Level-2-260C-1 YEAR	-40 to 125	HVD70
<a href="#">SN65HVD71D</a>	Active	Production	SOIC (D)   8	75   TUBE	Yes	NIPDAU	Level-1-260C-UNLIM	-40 to 125	HVD71
SN65HVD71D.B	Active	Production	SOIC (D)   8	75   TUBE	Yes	NIPDAU	Level-1-260C-UNLIM	-40 to 125	HVD71
<a href="#">SN65HVD71DGK</a>	Active	Production	VSSOP (DGK)   8	80   TUBE	Yes	NIPDAUAG	Level-1-260C-UNLIM	-40 to 125	VD71
SN65HVD71DGK.B	Active	Production	VSSOP (DGK)   8	80   TUBE	Yes	NIPDAUAG	Level-1-260C-UNLIM	-40 to 125	VD71
<a href="#">SN65HVD71DGKR</a>	Active	Production	VSSOP (DGK)   8	2500   LARGE T&R	Yes	NIPDAU   NIPDAUAG	Level-1-260C-UNLIM	-40 to 125	VD71
SN65HVD71DGKR.B	Active	Production	VSSOP (DGK)   8	2500   LARGE T&R	Yes	NIPDAU	Level-1-260C-UNLIM	-40 to 125	VD71
<a href="#">SN65HVD71DR</a>	Active	Production	SOIC (D)   8	2500   LARGE T&R	Yes	NIPDAU	Level-1-260C-UNLIM	-40 to 125	HVD71
SN65HVD71DR.B	Active	Production	SOIC (D)   8	2500   LARGE T&R	Yes	NIPDAU	Level-1-260C-UNLIM	-40 to 125	HVD71
SN65HVD71DRG4	Active	Production	SOIC (D)   8	2500   LARGE T&R	Yes	NIPDAU	Level-1-260C-UNLIM	-40 to 125	HVD71
SN65HVD71DRG4.B	Active	Production	SOIC (D)   8	2500   LARGE T&R	Yes	NIPDAU	Level-1-260C-UNLIM	-40 to 125	HVD71
<a href="#">SN65HVD73D</a>	Active	Production	SOIC (D)   14	50   TUBE	Yes	NIPDAU	Level-1-260C-UNLIM	-40 to 125	HVD73
SN65HVD73D.B	Active	Production	SOIC (D)   14	50   TUBE	Yes	NIPDAU	Level-1-260C-UNLIM	-40 to 125	HVD73
<a href="#">SN65HVD73DGS</a>	Active	Production	VSSOP (DGS)   10	80   TUBE	Yes	NIPDAUAG	Level-1-260C-UNLIM	-40 to 125	VD73
SN65HVD73DGS.B	Active	Production	VSSOP (DGS)   10	80   TUBE	Yes	NIPDAUAG	Level-1-260C-UNLIM	-40 to 125	VD73
<a href="#">SN65HVD73DGSR</a>	Active	Production	VSSOP (DGS)   10	2500   LARGE T&R	Yes	NIPDAUAG	Level-1-260C-UNLIM	-40 to 125	VD73
SN65HVD73DGSR.B	Active	Production	VSSOP (DGS)   10	2500   LARGE T&R	Yes	NIPDAUAG	Level-1-260C-UNLIM	-40 to 125	VD73
<a href="#">SN65HVD73DR</a>	Active	Production	SOIC (D)   14	2500   LARGE T&R	Yes	NIPDAU	Level-1-260C-UNLIM	-40 to 125	HVD73
SN65HVD73DR.B	Active	Production	SOIC (D)   14	2500   LARGE T&R	Yes	NIPDAU	Level-1-260C-UNLIM	-40 to 125	HVD73
<a href="#">SN65HVD74D</a>	Active	Production	SOIC (D)   8	75   TUBE	Yes	NIPDAU	Level-1-260C-UNLIM	-40 to 125	HVD74

Orderable part number	Status (1)	Material type (2)	Package   Pins	Package qty   Carrier	RoHS (3)	Lead finish/ Ball material (4)	MSL rating/ Peak reflow (5)	Op temp (°C)	Part marking (6)
SN65HVD74D.B	Active	Production	SOIC (D)   8	75   TUBE	Yes	NIPDAU	Level-1-260C-UNLIM	-40 to 125	HVD74
<a href="#">SN65HVD74DGK</a>	Active	Production	VSSOP (DGK)   8	80   TUBE	Yes	NIPDAUAG	Level-1-260C-UNLIM	-40 to 125	VD74
SN65HVD74DGK.B	Active	Production	VSSOP (DGK)   8	80   TUBE	Yes	NIPDAUAG	Level-1-260C-UNLIM	-40 to 125	VD74
<a href="#">SN65HVD74DGKR</a>	Active	Production	VSSOP (DGK)   8	2500   LARGE T&R	Yes	NIPDAU   SN   NIPDAUAG	Level-1-260C-UNLIM	-40 to 125	VD74
SN65HVD74DGKR.B	Active	Production	VSSOP (DGK)   8	2500   LARGE T&R	Yes	NIPDAU	Level-1-260C-UNLIM	-40 to 125	VD74
<a href="#">SN65HVD74DR</a>	Active	Production	SOIC (D)   8	2500   LARGE T&R	Yes	NIPDAU	Level-1-260C-UNLIM	-40 to 125	HVD74
SN65HVD74DR.B	Active	Production	SOIC (D)   8	2500   LARGE T&R	Yes	NIPDAU	Level-1-260C-UNLIM	-40 to 125	HVD74
SN65HVD74DRG4	Active	Production	SOIC (D)   8	2500   LARGE T&R	Yes	NIPDAU	Level-1-260C-UNLIM	-40 to 125	HVD74
SN65HVD74DRG4.B	Active	Production	SOIC (D)   8	2500   LARGE T&R	Yes	NIPDAU	Level-1-260C-UNLIM	-40 to 125	HVD74
<a href="#">SN65HVD76D</a>	Active	Production	SOIC (D)   14	50   TUBE	Yes	NIPDAU	Level-2-260C-1 YEAR	-40 to 125	HVD76
SN65HVD76D.A	Active	Production	SOIC (D)   14	50   TUBE	Yes	NIPDAU	Level-2-260C-1 YEAR	-40 to 125	HVD76
SN65HVD76D.B	Active	Production	SOIC (D)   14	50   TUBE	Yes	NIPDAU	Level-2-260C-1 YEAR	-40 to 125	HVD76
<a href="#">SN65HVD76DGS</a>	Active	Production	VSSOP (DGS)   10	80   TUBE	Yes	NIPDAUAG	Level-1-260C-UNLIM	-40 to 125	VD76
SN65HVD76DGS.A	Active	Production	VSSOP (DGS)   10	80   TUBE	Yes	NIPDAUAG	Level-1-260C-UNLIM	-40 to 125	VD76
SN65HVD76DGS.B	Active	Production	VSSOP (DGS)   10	80   TUBE	Yes	NIPDAUAG	Level-1-260C-UNLIM	-40 to 125	VD76
<a href="#">SN65HVD76DGSR</a>	Active	Production	VSSOP (DGS)   10	2500   LARGE T&R	Yes	NIPDAUAG	Level-2-260C-1 YEAR	-40 to 125	VD76
SN65HVD76DGSR.A	Active	Production	VSSOP (DGS)   10	2500   LARGE T&R	Yes	NIPDAUAG	Level-2-260C-1 YEAR	-40 to 125	VD76
SN65HVD76DGSR.B	Active	Production	VSSOP (DGS)   10	2500   LARGE T&R	Yes	NIPDAUAG	Level-2-260C-1 YEAR	-40 to 125	VD76
<a href="#">SN65HVD76DR</a>	Active	Production	SOIC (D)   14	2500   LARGE T&R	Yes	NIPDAU	Level-2-260C-1 YEAR	-40 to 125	HVD76
SN65HVD76DR.A	Active	Production	SOIC (D)   14	2500   LARGE T&R	Yes	NIPDAU	Level-2-260C-1 YEAR	-40 to 125	HVD76
SN65HVD76DR.B	Active	Production	SOIC (D)   14	2500   LARGE T&R	Yes	NIPDAU	Level-2-260C-1 YEAR	-40 to 125	HVD76
SN65HVD76DRG4	Active	Production	SOIC (D)   14	2500   LARGE T&R	Yes	NIPDAU	Level-2-260C-1 YEAR	-40 to 125	HVD76
SN65HVD76DRG4.A	Active	Production	SOIC (D)   14	2500   LARGE T&R	Yes	NIPDAU	Level-2-260C-1 YEAR	-40 to 125	HVD76
SN65HVD76DRG4.B	Active	Production	SOIC (D)   14	2500   LARGE T&R	Yes	NIPDAU	Level-2-260C-1 YEAR	-40 to 125	HVD76
<a href="#">SN65HVD77D</a>	Active	Production	SOIC (D)   8	75   TUBE	Yes	NIPDAU	Level-1-260C-UNLIM	-40 to 125	HVD77
SN65HVD77D.A	Active	Production	SOIC (D)   8	75   TUBE	Yes	NIPDAU	Level-1-260C-UNLIM	-40 to 125	HVD77
SN65HVD77D.B	Active	Production	SOIC (D)   8	75   TUBE	Yes	NIPDAU	Level-1-260C-UNLIM	-40 to 125	HVD77
<a href="#">SN65HVD77DGK</a>	Active	Production	VSSOP (DGK)   8	80   TUBE	Yes	NIPDAUAG	Level-1-260C-UNLIM	-40 to 125	VD77
SN65HVD77DGK.A	Active	Production	VSSOP (DGK)   8	80   TUBE	Yes	NIPDAUAG	Level-1-260C-UNLIM	-40 to 125	VD77
SN65HVD77DGK.B	Active	Production	VSSOP (DGK)   8	80   TUBE	Yes	NIPDAUAG	Level-1-260C-UNLIM	-40 to 125	VD77

Orderable part number	Status (1)	Material type (2)	Package   Pins	Package qty   Carrier	RoHS (3)	Lead finish/ Ball material (4)	MSL rating/ Peak reflow (5)	Op temp (°C)	Part marking (6)
<a href="#">SN65HVD77DGKR</a>	Active	Production	VSSOP (DGK)   8	2500   LARGE T&R	Yes	NIPDAU   NIPDAUAG	Level-1-260C-UNLIM	-40 to 125	VD77
SN65HVD77DGKR.A	Active	Production	VSSOP (DGK)   8	2500   LARGE T&R	Yes	NIPDAU	Level-1-260C-UNLIM	-40 to 125	VD77
SN65HVD77DGKR.B	Active	Production	VSSOP (DGK)   8	2500   LARGE T&R	Yes	NIPDAU	Level-1-260C-UNLIM	-40 to 125	VD77
<a href="#">SN65HVD77DR</a>	Active	Production	SOIC (D)   8	2500   LARGE T&R	Yes	NIPDAU	Level-1-260C-UNLIM	-40 to 125	HVD77
SN65HVD77DR.A	Active	Production	SOIC (D)   8	2500   LARGE T&R	Yes	NIPDAU	Level-1-260C-UNLIM	-40 to 125	HVD77
SN65HVD77DR.B	Active	Production	SOIC (D)   8	2500   LARGE T&R	Yes	NIPDAU	Level-1-260C-UNLIM	-40 to 125	HVD77
SN65HVD77DRG4	Active	Production	SOIC (D)   8	2500   LARGE T&R	Yes	NIPDAU	Level-1-260C-UNLIM	-40 to 125	HVD77
SN65HVD77DRG4.A	Active	Production	SOIC (D)   8	2500   LARGE T&R	Yes	NIPDAU	Level-1-260C-UNLIM	-40 to 125	HVD77
SN65HVD77DRG4.B	Active	Production	SOIC (D)   8	2500   LARGE T&R	Yes	NIPDAU	Level-1-260C-UNLIM	-40 to 125	HVD77

(1) **Status:** For more details on status, see our [product life cycle](#).

(2) **Material type:** When designated, preproduction parts are prototypes/experimental devices, and are not yet approved or released for full production. Testing and final process, including without limitation quality assurance, reliability performance testing, and/or process qualification, may not yet be complete, and this item is subject to further changes or possible discontinuation. If available for ordering, purchases will be subject to an additional waiver at checkout, and are intended for early internal evaluation purposes only. These items are sold without warranties of any kind.

(3) **RoHS values:** Yes, No, RoHS Exempt. See the [TI RoHS Statement](#) for additional information and value definition.

(4) **Lead finish/Ball material:** Parts may have multiple material finish options. Finish options are separated by a vertical ruled line. Lead finish/Ball material values may wrap to two lines if the finish value exceeds the maximum column width.

(5) **MSL rating/Peak reflow:** The moisture sensitivity level ratings and peak solder (reflow) temperatures. In the event that a part has multiple moisture sensitivity ratings, only the lowest level per JEDEC standards is shown. Refer to the shipping label for the actual reflow temperature that will be used to mount the part to the printed circuit board.

(6) **Part marking:** There may be an additional marking, which relates to the logo, the lot trace code information, or the environmental category of the part.

Multiple part markings will be inside parentheses. Only one part marking contained in parentheses and separated by a "~" will appear on a part. If a line is indented then it is a continuation of the previous line and the two combined represent the entire part marking for that device.

**Important Information and Disclaimer:** The information provided on this page represents TI's knowledge and belief as of the date that it is provided. TI bases its knowledge and belief on information provided by third parties, and makes no representation or warranty as to the accuracy of such information. Efforts are underway to better integrate information from third parties. TI has taken and continues to take reasonable steps to provide representative and accurate information but may not have conducted destructive testing or chemical analysis on incoming materials and chemicals. TI and TI suppliers consider certain information to be proprietary, and thus CAS numbers and other limited information may not be available for release.

In no event shall TI's liability arising out of such information exceed the total purchase price of the TI part(s) at issue in this document sold by TI to Customer on an annual basis.

**TAPE AND REEL INFORMATION**

**QUADRANT ASSIGNMENTS FOR PIN 1 ORIENTATION IN TAPE**



\*All dimensions are nominal

Device	Package Type	Package Drawing	Pins	SPQ	Reel Diameter (mm)	Reel Width W1 (mm)	A0 (mm)	B0 (mm)	K0 (mm)	P1 (mm)	W (mm)	Pin1 Quadrant
SN65HVD70DGSR	VSSOP	DGS	10	2500	330.0	12.4	5.3	3.4	1.4	8.0	12.0	Q1
SN65HVD70DR	SOIC	D	14	2500	330.0	16.4	6.5	9.0	2.1	8.0	16.0	Q1
SN65HVD70DRG4	SOIC	D	14	2500	330.0	16.4	6.5	9.0	2.1	8.0	16.0	Q1
SN65HVD71DGKR	VSSOP	DGK	8	2500	330.0	12.4	5.3	3.4	1.4	8.0	12.0	Q1
SN65HVD71DR	SOIC	D	8	2500	330.0	12.5	6.4	5.2	2.1	8.0	12.0	Q1
SN65HVD71DRG4	SOIC	D	8	2500	330.0	12.5	6.4	5.2	2.1	8.0	12.0	Q1
SN65HVD73DGSR	VSSOP	DGS	10	2500	330.0	12.4	5.3	3.4	1.4	8.0	12.0	Q1
SN65HVD74DGKR	VSSOP	DGK	8	2500	330.0	12.4	5.3	3.4	1.4	8.0	12.0	Q1
SN65HVD74DR	SOIC	D	8	2500	330.0	12.5	6.4	5.2	2.1	8.0	12.0	Q1
SN65HVD74DRG4	SOIC	D	8	2500	330.0	12.5	6.4	5.2	2.1	8.0	12.0	Q1
SN65HVD76DGSR	VSSOP	DGS	10	2500	330.0	12.4	5.3	3.4	1.4	8.0	12.0	Q1
SN65HVD76DR	SOIC	D	14	2500	330.0	16.4	6.5	9.0	2.1	8.0	16.0	Q1
SN65HVD76DRG4	SOIC	D	14	2500	330.0	16.4	6.5	9.0	2.1	8.0	16.0	Q1
SN65HVD77DGKR	VSSOP	DGK	8	2500	330.0	12.4	5.3	3.4	1.4	8.0	12.0	Q1
SN65HVD77DR	SOIC	D	8	2500	330.0	12.5	6.4	5.2	2.1	8.0	12.0	Q1
SN65HVD77DRG4	SOIC	D	8	2500	330.0	12.5	6.4	5.2	2.1	8.0	12.0	Q1

**TAPE AND REEL BOX DIMENSIONS**

\*All dimensions are nominal

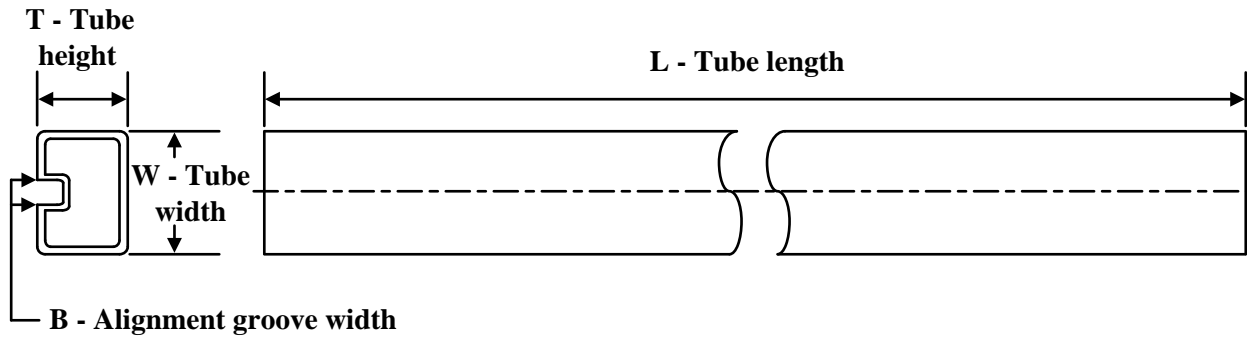
Device	Package Type	Package Drawing	Pins	SPQ	Length (mm)	Width (mm)	Height (mm)
SN65HVD70DGSR	VSSOP	DGS	10	2500	364.0	364.0	27.0
SN65HVD70DR	SOIC	D	14	2500	353.0	353.0	32.0
SN65HVD70DRG4	SOIC	D	14	2500	353.0	353.0	32.0
SN65HVD71DGKR	VSSOP	DGK	8	2500	353.0	353.0	32.0
SN65HVD71DR	SOIC	D	8	2500	353.0	353.0	32.0
SN65HVD71DRG4	SOIC	D	8	2500	353.0	353.0	32.0
SN65HVD73DGSR	VSSOP	DGS	10	2500	364.0	364.0	27.0
SN65HVD74DGKR	VSSOP	DGK	8	2500	353.0	353.0	32.0
SN65HVD74DR	SOIC	D	8	2500	353.0	353.0	32.0
SN65HVD74DRG4	SOIC	D	8	2500	353.0	353.0	32.0
SN65HVD76DGSR	VSSOP	DGS	10	2500	366.0	364.0	50.0
SN65HVD76DR	SOIC	D	14	2500	340.5	336.1	32.0
SN65HVD76DRG4	SOIC	D	14	2500	340.5	336.1	32.0
SN65HVD77DGKR	VSSOP	DGK	8	2500	353.0	353.0	32.0
SN65HVD77DR	SOIC	D	8	2500	353.0	353.0	32.0
SN65HVD77DRG4	SOIC	D	8	2500	353.0	353.0	32.0

**TUBE**

\*All dimensions are nominal

Device	Package Name	Package Type	Pins	SPQ	L (mm)	W (mm)	T (µm)	B (mm)
SN65HVD70D	D	SOIC	14	50	507	7.85	3750	2.24
SN65HVD70D.B	D	SOIC	14	50	507	7.85	3750	2.24
SN65HVD70DGS	DGS	VSSOP	10	80	330	6.55	500	2.88
SN65HVD70DGS.B	DGS	VSSOP	10	80	330	6.55	500	2.88
SN65HVD71D	D	SOIC	8	75	507	8	3940	4.32
SN65HVD71D.B	D	SOIC	8	75	507	8	3940	4.32
SN65HVD71DGK	DGK	VSSOP	8	80	330	6.55	500	2.88
SN65HVD71DGK.B	DGK	VSSOP	8	80	330	6.55	500	2.88
SN65HVD73D	D	SOIC	14	50	507	7.85	3750	2.24
SN65HVD73D.B	D	SOIC	14	50	507	7.85	3750	2.24
SN65HVD73DGS	DGS	VSSOP	10	80	330	6.55	500	2.88
SN65HVD73DGS.B	DGS	VSSOP	10	80	330	6.55	500	2.88
SN65HVD74D	D	SOIC	8	75	507	8	3940	4.32
SN65HVD74D.B	D	SOIC	8	75	507	8	3940	4.32
SN65HVD74DGK	DGK	VSSOP	8	80	330	6.55	500	2.88
SN65HVD74DGK.B	DGK	VSSOP	8	80	330	6.55	500	2.88
SN65HVD76D	D	SOIC	14	50	507	7.85	3750	2.24
SN65HVD76D.A	D	SOIC	14	50	507	7.85	3750	2.24
SN65HVD76D.B	D	SOIC	14	50	507	7.85	3750	2.24
SN65HVD76DGS	DGS	VSSOP	10	80	330	6.55	500	2.88
SN65HVD76DGS.A	DGS	VSSOP	10	80	330	6.55	500	2.88
SN65HVD76DGS.B	DGS	VSSOP	10	80	330	6.55	500	2.88
SN65HVD77D	D	SOIC	8	75	507	8	3940	4.32
SN65HVD77D.A	D	SOIC	8	75	507	8	3940	4.32
SN65HVD77D.B	D	SOIC	8	75	507	8	3940	4.32
SN65HVD77DGK	DGK	VSSOP	8	80	330	6.55	500	2.88
SN65HVD77DGK.A	DGK	VSSOP	8	80	330	6.55	500	2.88
SN65HVD77DGK.B	DGK	VSSOP	8	80	330	6.55	500	2.88

DGK0008A



# PACKAGE OUTLINE

VSSOP - 1.1 mm max height

SMALL OUTLINE PACKAGE



4214862/A 04/2023

NOTES:

PowerPAD is a trademark of Texas Instruments.

1. All linear dimensions are in millimeters. Any dimensions in parenthesis are for reference only. Dimensioning and tolerancing per ASME Y14.5M.
2. This drawing is subject to change without notice.
3. This dimension does not include mold flash, protrusions, or gate burrs. Mold flash, protrusions, or gate burrs shall not exceed 0.15 mm per side.
4. This dimension does not include interlead flash. Interlead flash shall not exceed 0.25 mm per side.
5. Reference JEDEC registration MO-187.

# EXAMPLE BOARD LAYOUT

DGK0008A

<sup>TM</sup> VSSOP - 1.1 mm max height

SMALL OUTLINE PACKAGE



LAND PATTERN EXAMPLE  
EXPOSED METAL SHOWN  
SCALE: 15X



4214862/A 04/2023

NOTES: (continued)

6. Publication IPC-7351 may have alternate designs.
7. Solder mask tolerances between and around signal pads can vary based on board fabrication site.
8. Vias are optional depending on application, refer to device data sheet. If any vias are implemented, refer to their locations shown on this view. It is recommended that vias under paste be filled, plugged or tented.
9. Size of metal pad may vary due to creepage requirement.

# EXAMPLE STENCIL DESIGN

DGK0008A

<sup>TM</sup> VSSOP - 1.1 mm max height

SMALL OUTLINE PACKAGE



SOLDER PASTE EXAMPLE  
SCALE: 15X

4214862/A 04/2023

NOTES: (continued)

11. Laser cutting apertures with trapezoidal walls and rounded corners may offer better paste release. IPC-7525 may have alternate design recommendations.
12. Board assembly site may have different recommendations for stencil design.



# D0014A

# PACKAGE OUTLINE

## SOIC - 1.75 mm max height

SMALL OUTLINE INTEGRATED CIRCUIT



4220718/A 09/2016

### NOTES:

1. All linear dimensions are in millimeters. Dimensions in parenthesis are for reference only. Dimensioning and tolerancing per ASME Y14.5M.
2. This drawing is subject to change without notice.
3. This dimension does not include mold flash, protrusions, or gate burrs. Mold flash, protrusions, or gate burrs shall not exceed 0.15 mm, per side.
4. This dimension does not include interlead flash. Interlead flash shall not exceed 0.43 mm, per side.
5. Reference JEDEC registration MS-012, variation AB.

# EXAMPLE BOARD LAYOUT

D0014A

SOIC - 1.75 mm max height

SMALL OUTLINE INTEGRATED CIRCUIT



LAND PATTERN EXAMPLE  
SCALE:8X



SOLDER MASK DETAILS

4220718/A 09/2016

NOTES: (continued)

- 6. Publication IPC-7351 may have alternate designs.
- 7. Solder mask tolerances between and around signal pads can vary based on board fabrication site.

# EXAMPLE STENCIL DESIGN

D0014A

SOIC - 1.75 mm max height

SMALL OUTLINE INTEGRATED CIRCUIT



SOLDER PASTE EXAMPLE  
BASED ON 0.125 mm THICK STENCIL  
SCALE:8X

4220718/A 09/2016

NOTES: (continued)

8. Laser cutting apertures with trapezoidal walls and rounded corners may offer better paste release. IPC-7525 may have alternate design recommendations.
9. Board assembly site may have different recommendations for stencil design.

# DGS0010A

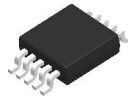

# PACKAGE OUTLINE

## VSSOP - 1.1 mm max height

SMALL OUTLINE PACKAGE

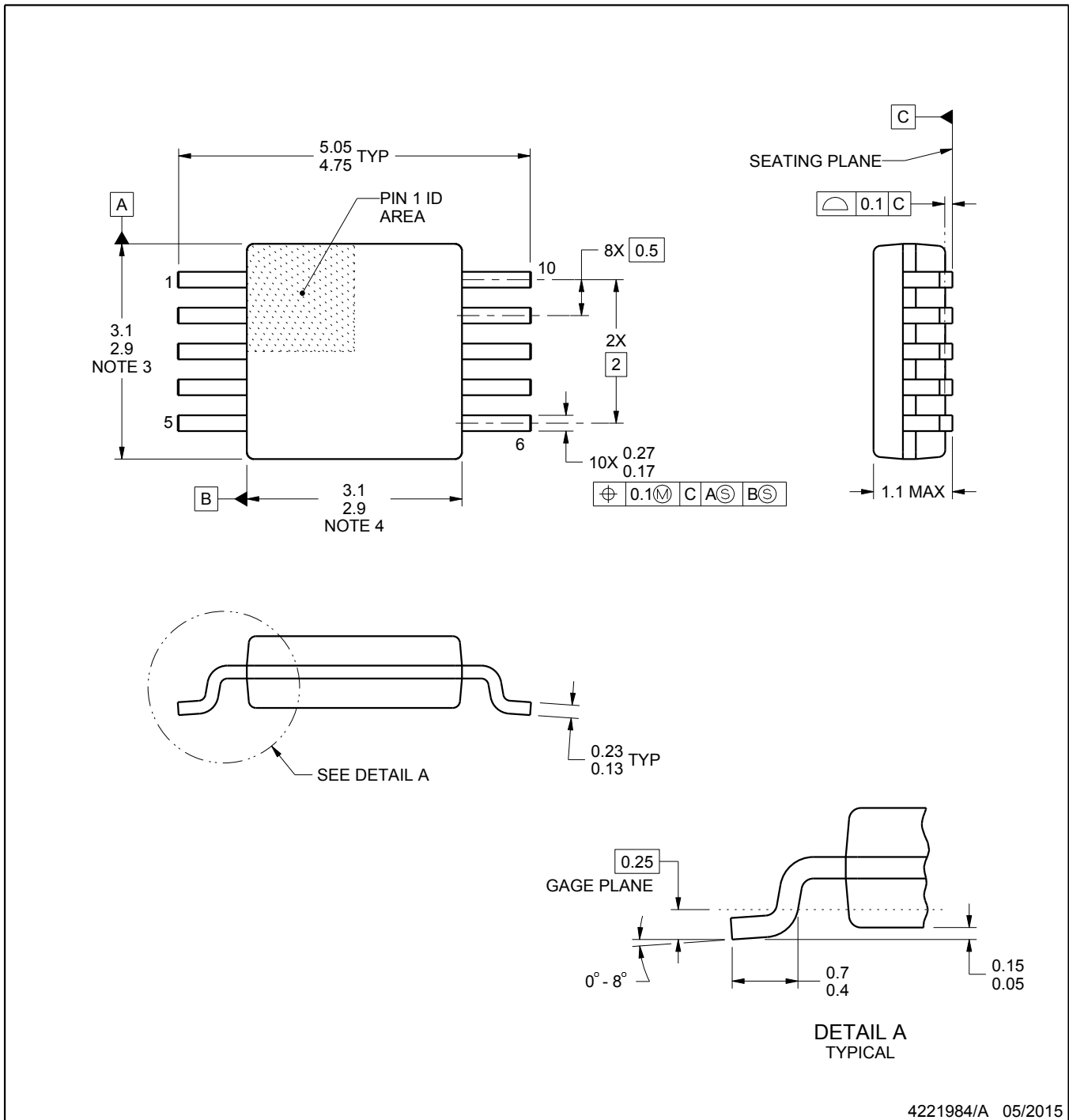

4221984/A 05/2015

### NOTES:

1. All linear dimensions are in millimeters. Any dimensions in parenthesis are for reference only. Dimensioning and tolerancing per ASME Y14.5M.
2. This drawing is subject to change without notice.
3. This dimension does not include mold flash, protrusions, or gate burrs. Mold flash, protrusions, or gate burrs shall not exceed 0.15 mm per side.
4. This dimension does not include interlead flash. Interlead flash shall not exceed 0.25 mm per side.
5. Reference JEDEC registration MO-187, variation BA.

# EXAMPLE BOARD LAYOUT

DGS0010A

VSSOP - 1.1 mm max height

SMALL OUTLINE PACKAGE

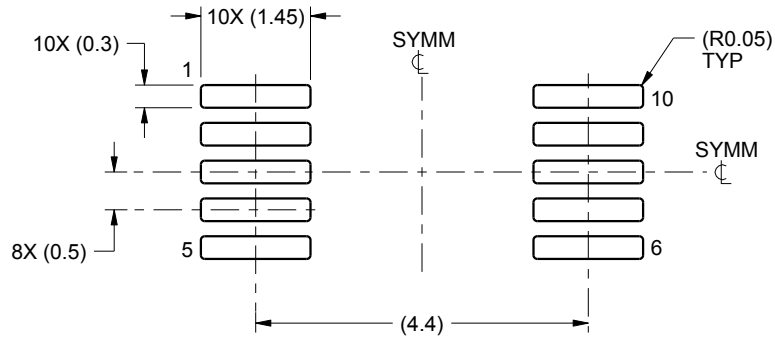

LAND PATTERN EXAMPLE  
SCALE:10X

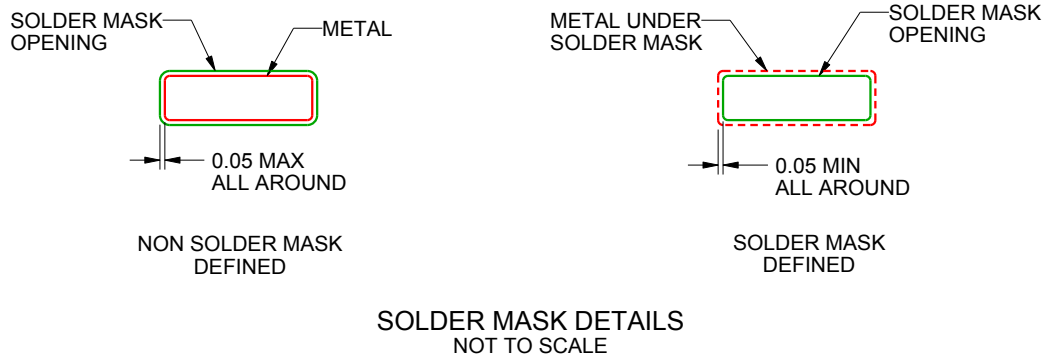

SOLDER MASK DETAILS  
NOT TO SCALE

4221984/A 05/2015

NOTES: (continued)

- 6. Publication IPC-7351 may have alternate designs.
- 7. Solder mask tolerances between and around signal pads can vary based on board fabrication site.

# EXAMPLE STENCIL DESIGN

DGS0010A

VSSOP - 1.1 mm max height

SMALL OUTLINE PACKAGE

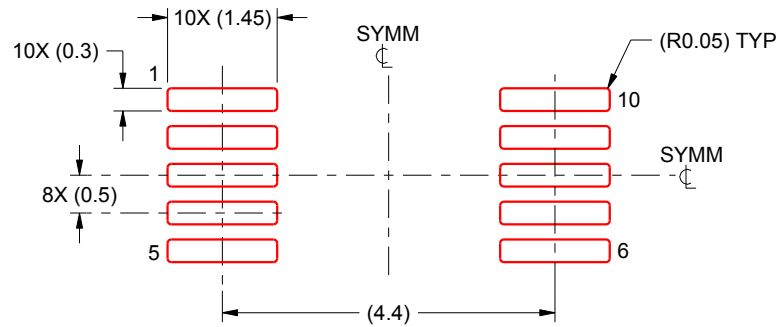

SOLDER PASTE EXAMPLE  
BASED ON 0.125 mm THICK STENCIL  
SCALE:10X

4221984/A 05/2015

NOTES: (continued)

8. Laser cutting apertures with trapezoidal walls and rounded corners may offer better paste release. IPC-7525 may have alternate design recommendations.
9. Board assembly site may have different recommendations for stencil design.



D0008A

# PACKAGE OUTLINE

SOIC - 1.75 mm max height

SMALL OUTLINE INTEGRATED CIRCUIT



4214825/C 02/2019

NOTES:

- Linear dimensions are in inches [millimeters]. Dimensions in parenthesis are for reference only. Controlling dimensions are in inches. Dimensioning and tolerancing per ASME Y14.5M.
- This drawing is subject to change without notice.
- This dimension does not include mold flash, protrusions, or gate burrs. Mold flash, protrusions, or gate burrs shall not exceed  $.006$  [0.15] per side.
- This dimension does not include interlead flash.
- Reference JEDEC registration MS-012, variation AA.

# EXAMPLE BOARD LAYOUT

D0008A

SOIC - 1.75 mm max height

SMALL OUTLINE INTEGRATED CIRCUIT



LAND PATTERN EXAMPLE  
 EXPOSED METAL SHOWN  
 SCALE:8X



SOLDER MASK DETAILS

4214825/C 02/2019

NOTES: (continued)

- 6. Publication IPC-7351 may have alternate designs.
- 7. Solder mask tolerances between and around signal pads can vary based on board fabrication site.

# EXAMPLE STENCIL DESIGN

D0008A

SOIC - 1.75 mm max height

SMALL OUTLINE INTEGRATED CIRCUIT



SOLDER PASTE EXAMPLE  
BASED ON .005 INCH [0.125 MM] THICK STENCIL  
SCALE:8X

4214825/C 02/2019

NOTES: (continued)

8. Laser cutting apertures with trapezoidal walls and rounded corners may offer better paste release. IPC-7525 may have alternate design recommendations.
9. Board assembly site may have different recommendations for stencil design.

## 重要なお知らせと免責事項

TI は、技術データと信頼性データ (データシートを含みます)、設計リソース (リファレンス デザインを含みます)、アプリケーションや設計に関する各種アドバイス、Web ツール、安全性情報、その他のリソースを、欠陥が存在する可能性のある「現状のまま」提供しており、商品性および特定目的に対する適合性の黙示保証、第三者の知的財産権の非侵害保証を含むいかなる保証も、明示的または黙示的にかかわらず拒否します。

これらのリソースは、TI 製品を使用する設計の経験を積んだ開発者への提供を意図したものです。(1) お客様のアプリケーションに適した TI 製品の選定、(2) お客様のアプリケーションの設計、検証、試験、(3) お客様のアプリケーションに該当する各種規格や、その他のあらゆる安全性、セキュリティ、規制、または他の要件への確実な適合に関する責任を、お客様のみが単独で負うものとし、

上記の各種リソースは、予告なく変更される可能性があります。これらのリソースは、リソースで説明されている TI 製品を使用するアプリケーションの開発の目的でのみ、TI はその使用をお客様に許諾します。これらのリソースに関して、他の目的で複製することや掲載することは禁止されています。TI や第三者の知的財産権のライセンスが付与されている訳ではありません。お客様は、これらのリソースを自身で使用した結果発生するあらゆる申し立て、損害、費用、損失、責任について、TI およびその代理人を完全に補償するものとし、TI は一切の責任を拒否します。

TI の製品は、[TI の販売条件](#)、[TI の総合的な品質ガイドライン](#)、[ti.com](#) または TI 製品などに関連して提供される他の適用条件に従い提供されます。TI がこれらのリソースを提供することは、適用される TI の保証または他の保証の放棄の拡大や変更を意味するものではありません。TI がカスタム、またはカスタマー仕様として明示的に指定していない限り、TI の製品は標準的なカタログに掲載される汎用機器です。

お客様がいかなる追加条項または代替条項を提案する場合も、TI はそれらに異議を唱え、拒否します。

Copyright © 2026, Texas Instruments Incorporated

最終更新日 : 2025 年 10 月