

SN75ALS161

OCTAL GENERAL-PURPOSE INTERFACE BUS TRANSCEIVERS

SLLS019F – JUNE 1986 – REVISED JULY 2004

- Suitable for IEEE Standard 488-1978 (GPIB)
- 8-Channel Bidirectional Transceivers
- Designed to Implement Control Bus Interface
- Designed for Single Controller
- High-Speed Advanced Low-Power Schottky Circuitry
- Low Power Dissipation . . . 46 mW Max Per Channel
- Fast Propagation Times . . . 20 ns Max
- High-Impedance pnp Inputs
- Receiver Hysteresis . . . 650 mV Typ
- Bus-Terminating Resistors Provided on Driver Outputs
- No Loading of Bus When Device Is Powered Down ($V_{CC} = 0$)
- Power-Up/Power-Down Protection (Glitch Free)

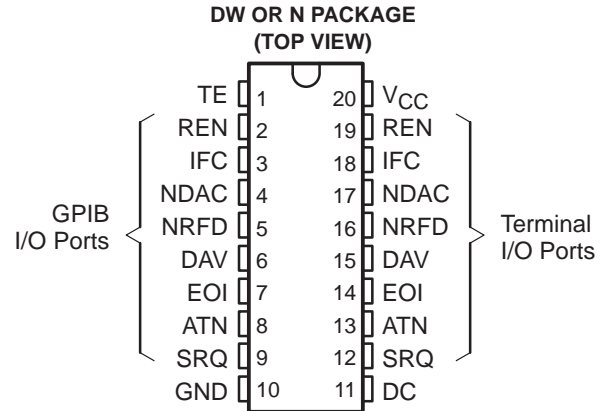

description/ordering information

The SN75ALS161 eight-channel general-purpose interface bus transceivers are high-speed, advanced low-power Schottky-process devices designed to provide the bus-management and data-transfer signals between operating units of a single-controller instrumentation system. When combined with the SN75ALS160 octal bus transceivers, this device provides a complete 16-wire interface for the IEEE 488 bus.

The SN75ALS161 device features eight driver-receiver pairs connected in a front-to-back configuration to form input/output (I/O) ports at both the bus and terminal sides. The direction of data through these driver-receiver pairs is determined by the direction-control (DC) and talk-enable (TE) signals.

The driver outputs general-purpose interface bus (GPIB I/O ports) feature active bus-terminating resistor circuits designed to provide a high impedance to the bus when $V_{CC} = 0$. The drivers are designed to handle sink-current loads up to 48 mA. Each receiver features pnp transistor inputs for high input impedance and hysteresis of 400 mV on the commercial part, and 250 mV on the military part, minimum, for increased noise immunity. All receivers have 3-state outputs, to present a high impedance to the terminal when disabled.

The SN75ALS161 is characterized for operation from 0°C to 70°C.

CHANNEL-IDENTIFICATION TABLE

NAME	IDENTITY	CLASS
DC	Direction Control	Control
TE	Talk Enable	
ATN	Attention	Bus Management
SRQ	Service Request	
REN	Remote Enable	
IFC	Interface Clear	
EOI	End or Identify	
DAV	Data Valid	Data Transfer
NDAC	Not Data Accepted	
NRFD	Not Ready for Data	

ORDERING INFORMATION

TA	PACKAGE†		ORDERABLE PART NUMBER	TOP-SIDE MARKING
0°C to 70°C	PDIP (N)	Tube of 20	SN75ALS161N	SN75ALS161N
		Tube of 25	SN75ALS161DW	75ALS161
	SOIC (DW)	Reel of 2000	SN75ALS161DWR	

† Package drawings, standard packing quantities, thermal data, symbolization, and PCB design guidelines are available at www.ti.com/sc/package.



Please be aware that an important notice concerning availability, standard warranty, and use in critical applications of Texas Instruments semiconductor products and disclaimers thereto appears at the end of this data sheet.

PRODUCTION DATA information is current as of publication date. Products conform to specifications per the terms of Texas Instruments standard warranty. Production processing does not necessarily include testing of all parameters.

**TEXAS
INSTRUMENTS**

POST OFFICE BOX 655303 • DALLAS, TEXAS 75265

Copyright © 2004, Texas Instruments Incorporated

SN75ALS161

OCTAL GENERAL-PURPOSE INTERFACE BUS TRANSCEIVERS

SLLS019F – JUNE 1986 – REVISED JULY 2004

FUNCTION TABLE
RECEIVE/TRANSMIT

CONTROLS			BUS-MANAGEMENT CHANNELS				DATA-TRANSFER CHANNELS			
DC	TE	ATN [†]	ATN [†]	SRQ	REN	IFC	EOI	DAV	NDAC	NRFD
			(CONTROLLED BY DC)					(CONTROLLED BY TE)		
H	H	H	R	T	R	R	T	T	R	R
H	H	L					R			
L	L	H	T	R	T	T	R	R	T	T
L	L	L					T			
H	L	X	R	T	R	R	R	R	T	T
L	H	X	T	R	T	T	T	T	R	R

H = high level, L = low level, R = receive, T = transmit, X = irrelevant

Direction of data transmission is from the terminal side to the bus side, and the direction of data receiving is from the bus side to the terminal side.

Data transfer is noninverting in both directions.

[†] ATN is a normal transceiver channel that functions additionally as an internal direction control or talk enable for EOI whenever the DC and TE inputs are in the same state. When DC and TE are in opposite states, the ATN channel functions as an independent transceiver only.

SN75ALS161 OCTAL GENERAL-PURPOSE INTERFACE BUS TRANSCEIVERS

SLLS019F – JUNE 1986 – REVISED JULY 2004

logic diagram (positive logic)

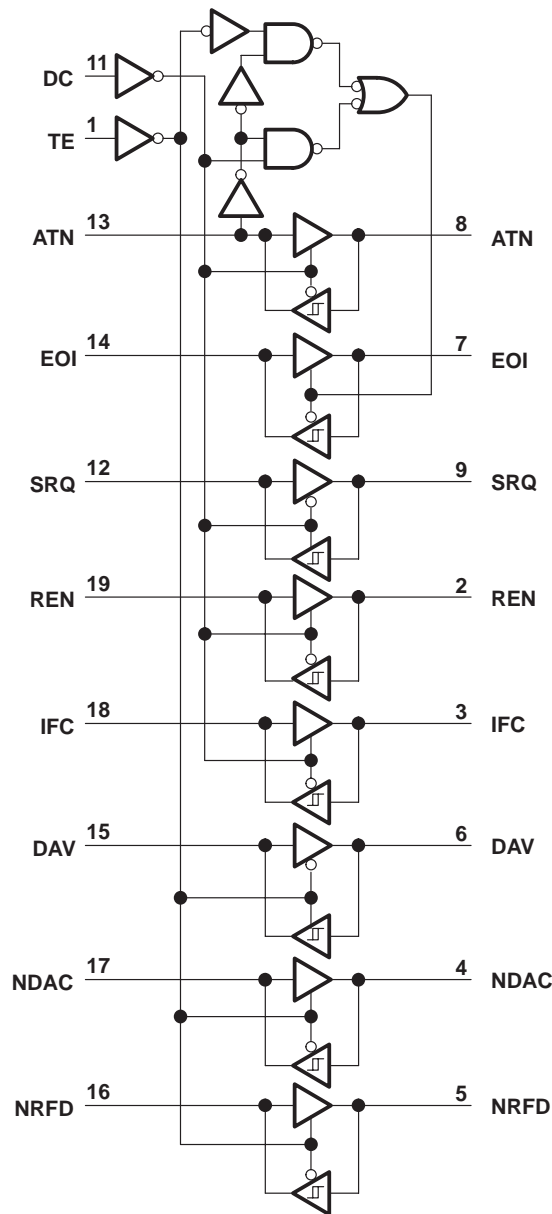

SN75ALS161 OCTAL GENERAL-PURPOSE INTERFACE BUS TRANSCEIVERS

SLLS019F – JUNE 1986 – REVISED JULY 2004

schematics of inputs and outputs

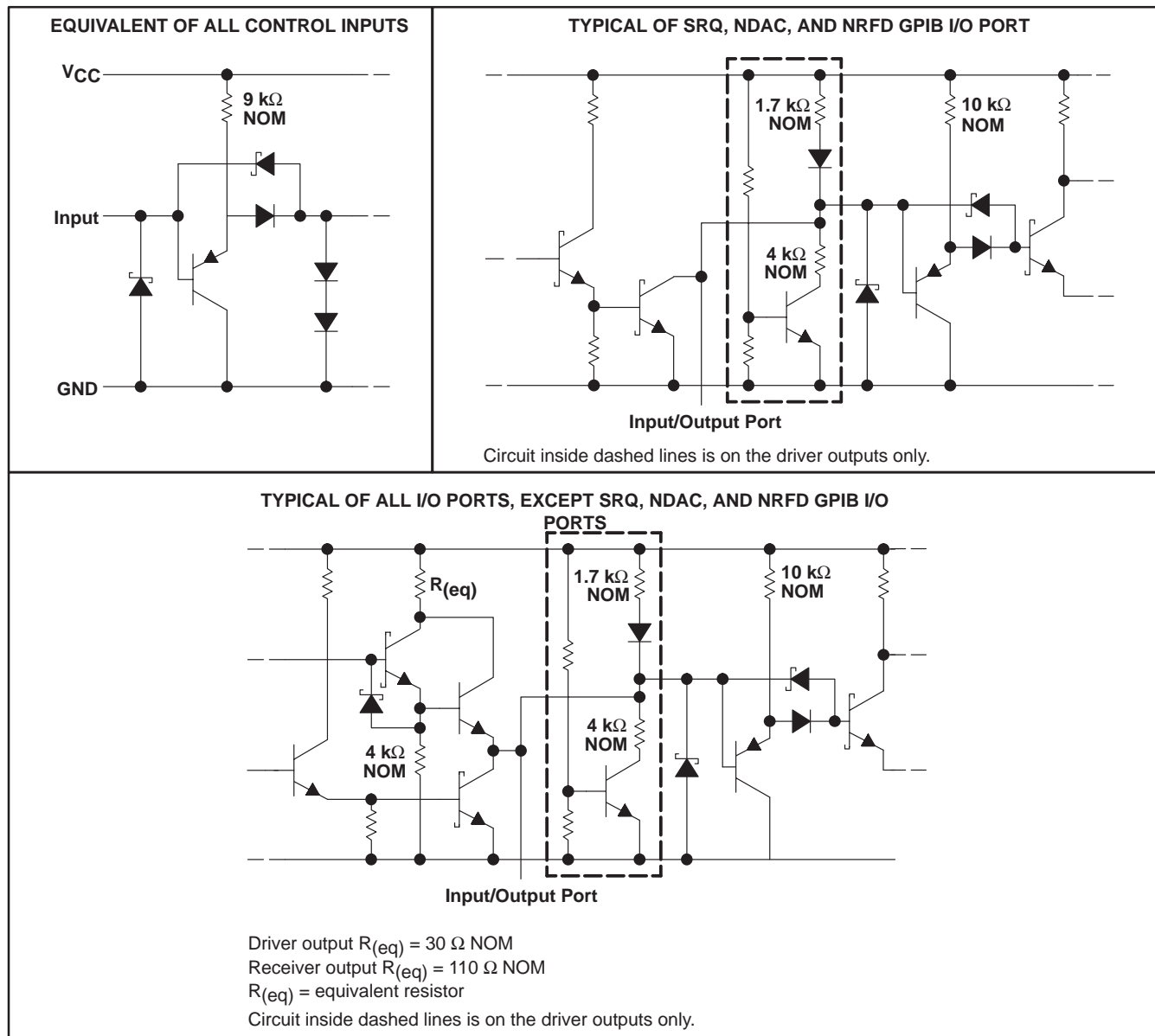

SN75ALS161

OCTAL GENERAL-PURPOSE INTERFACE BUS TRANSCEIVERS

SLLS019F – JUNE 1986 – REVISED JULY 2004

absolute maximum ratings over operating free-air temperature range (unless otherwise noted)†

Supply voltage, V_{CC} (see Note 1)	7 V
Input voltage, V_I	5.5 V
Low-level driver output current, I_{OL}	100 mA
Package thermal impedance, θ_{JA} (see Notes 2 and 3): DW package	58°C/W
N package	69°C/W
Operating virtual junction temperature, T_J	150°C
Storage temperature range, T_{Stg}	–65°C to 150°C

† Stresses beyond those listed under “absolute maximum ratings” may cause permanent damage to the device. These are stress ratings only, and functional operation of the device at these or any other conditions beyond those indicated under “recommended operating conditions” is not implied. Exposure to absolute-maximum-rated conditions for extended periods may affect device reliability.

- NOTES: 1. All voltage values are with respect to network ground terminal.
 2. Maximum power dissipation is a function of $T_{J(max)}$, θ_{JA} , and T_A . The maximum allowable power dissipation at any allowable ambient temperature is $P_D = (T_{J(max)} - T_A)/\theta_{JA}$. Operating at the absolute maximum T_J of 150°C can affect reliability.
 3. The package thermal impedance is calculated in accordance with JESD 51-7.

recommended operating conditions

		MIN	NOM	MAX	UNIT
V_{CC}	Supply voltage	4.75	5	5.25	V
V_{IH}	High-level input voltage	2			V
V_{IL}	Low-level input voltage			0.8	V
I_{OH}	High-level output current	Bus ports with pullups active		– 5.2	mA
		Terminal ports		– 800	μA
I_{OL}	Low-level output current	Bus ports		48	mA
		Terminal ports		16	
T_A	Operating free-air temperature	0		70	°C



SN75ALS161

OCTAL GENERAL-PURPOSE INTERFACE BUS TRANSCEIVERS

SLLS019F – JUNE 1986 – REVISED JULY 2004

electrical characteristics over recommended ranges of supply voltage and operating free-air temperature (unless otherwise noted)

PARAMETER		TEST CONDITIONS†		MIN	TYP‡	MAX	UNIT	
V_{IK}	Input clamp voltage	$I_I = -18 \text{ mA}$		-0.8	-1.5		V	
V_{hys}	Hysteresis voltage ($V_{IT+} - V_{IT-}$)	Bus		0.4	0.65		V	
$V_{OH}§$	High-level output voltage	Terminal	$I_{OH} = -800 \mu\text{A}$, $V_{CC} = \text{MIN}$	$T_A = 25^\circ\text{C}$ and MAX	2.7	3.5	V	
				$T_A = \text{MIN}$	2.7	3.5		
		Bus	$I_{OH} = -5.2 \text{ mA}$, $V_{CC} = \text{MIN}$	$T_A = 25^\circ\text{C}$ and MAX	2.2			
				$T_A = \text{MIN}$	2.2			
V_{OL}	Low-level output voltage	Terminal	$I_{OL} = 16 \text{ mA}$, $V_{CC} = \text{MIN}$		0.3	0.5	V	
		Bus	$I_{OL} = 48 \text{ mA}$, $V_{CC} = \text{MIN}$		0.35	0.5		
I_I	Input current at maximum input voltage	Terminal	$V_I = 5.5 \text{ V}$, $V_{CC} = \text{MAX}$		0.2	100	μA	
I_{IH}	High-level input current	Terminal and control inputs	$V_I = 2.7 \text{ V}$, $V_{CC} = \text{MAX}$		0.1	20	μA	
$V_{I/O}$	Voltage at GPIB I/O port	$I_I(\text{bus}) = 0$		2.5	3	3.7	V	
		$I_I(\text{bus}) = 0$		2.5	3	3.7		
		$I_I(\text{bus}) = -12 \text{ mA}$				-1.5		
I_{IL}	Low-level input current	Terminal and control inputs	$V_I = 0.5 \text{ V}$, $V_{CC} = \text{MAX}$		-10	-100	μA	
$I_{I/O}$	Current into GPIB I/O port	Power on	$V_I(\text{bus}) = -1.5 \text{ V to } 0.4 \text{ V}$		-1.3		mA	
			$V_I(\text{bus}) = 0.4 \text{ V to } 2.5 \text{ V}$		0			-3.2
			$V_I(\text{bus}) = 2.5 \text{ V to } 3.7 \text{ V}$					2.5
			$V_I(\text{bus}) = 3.7 \text{ V to } 5 \text{ V}$		0			2.5
			$V_I(\text{bus}) = 5 \text{ V to } 5.5 \text{ V}$		0.7			2.5
		Power off	$V_{CC} = 0$	$V_I(\text{bus}) = 0 \text{ to } 2.5 \text{ V}$				40
$I_{OS}§$	Short-circuit output current	Terminal	$V_{CC} = \text{MAX}$		-15	-35	-75	mA
		Bus	$V_{CC} = \text{MAX}$		-25	-50	-125	
I_{CC}	Supply current	No load, TE and DC low, $V_{CC} = \text{MAX}$			55	75	mA	
$C_{I/O}$	GPIB I/O port capacitance	$V_{CC} = 0 \text{ to } 5 \text{ V}$, $V_{I/O} = 0 \text{ to } 2 \text{ V}$, $f = 1 \text{ MHz}$			30		pF	

† For conditions shown as MIN or MAX, use the appropriate value specified under recommended operating conditions.

‡ All typical values are at $V_{CC} = 5 \text{ V}$, $T_A = 25^\circ\text{C}$.

§ V_{OH} and I_{OS} apply to 3-state outputs only.



SN75ALS161

OCTAL GENERAL-PURPOSE INTERFACE BUS TRANSCEIVERS

SLLS019F – JUNE 1986 – REVISED JULY 2004

switching characteristics over recommended operating free-air temperature range, $V_{CC} = 5\text{ V}$

PARAMETER		FROM (INPUT)	TO (OUTPUT)	TEST CONDITIONS	MIN	TYP†	MAX	UNIT
t_{PLH}	Propagation delay time, low- to high-level output	Terminal	Bus	$C_L = 30\text{ pF}$, See Figure 1		10	20	ns
t_{PHL}	Propagation delay time, high- to low-level output					12	20	
t_{PLH}	Propagation delay time, low- to high-level output	Bus	Terminal	$C_L = 30\text{ pF}$, See Figure 2		5	10	ns
t_{PHL}	Propagation delay time, high- to low-level output					7	14	
t_{PZH}	Output enable time to high level	TE or DC	Bus (ATN, EOI, REN, IFC, and DAV)	$C_L = 15\text{ pF}$, See Figure 3			30	ns
t_{PHZ}	Output disable time from high level						20	
t_{PZL}	Output enable time to low level						45	
t_{PLZ}	Output disable time from low level						20	
t_{PZH}	Output enable time to high level	TE or DC	Terminal	$C_L = 15\text{ pF}$, See Figure 4			30	ns
t_{PHZ}	Output disable time from high level						25	
t_{PZL}	Output enable time to low level						30	
t_{PLZ}	Output disable time from low level						25	

† All typical values are at $T_A = 25^\circ\text{C}$.

SN75ALS161 OCTAL GENERAL-PURPOSE INTERFACE BUS TRANSCEIVERS

SLLS019F – JUNE 1986 – REVISED JULY 2004

PARAMETER MEASUREMENT INFORMATION

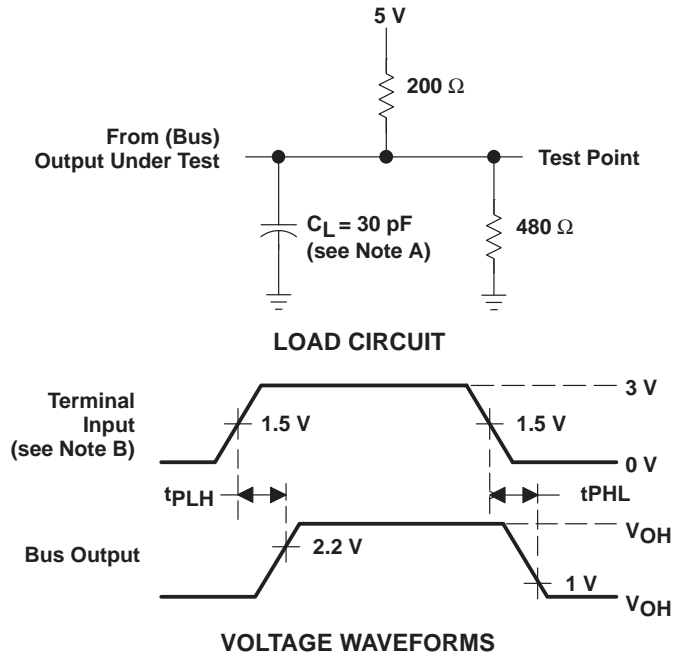

- NOTES: A. C_L includes probe and jig capacitance.
 B. The input pulse is supplied by a generator having the following characteristics: $PRR \leq 1 \text{ MHz}$, 50% duty cycle, $t_r \leq 6 \text{ ns}$, $t_f \leq 6 \text{ ns}$, $Z_O = 50 \Omega$.

Figure 1. Terminal-to-Bus Load Circuit and Voltage Waveforms

PARAMETER MEASUREMENT INFORMATION

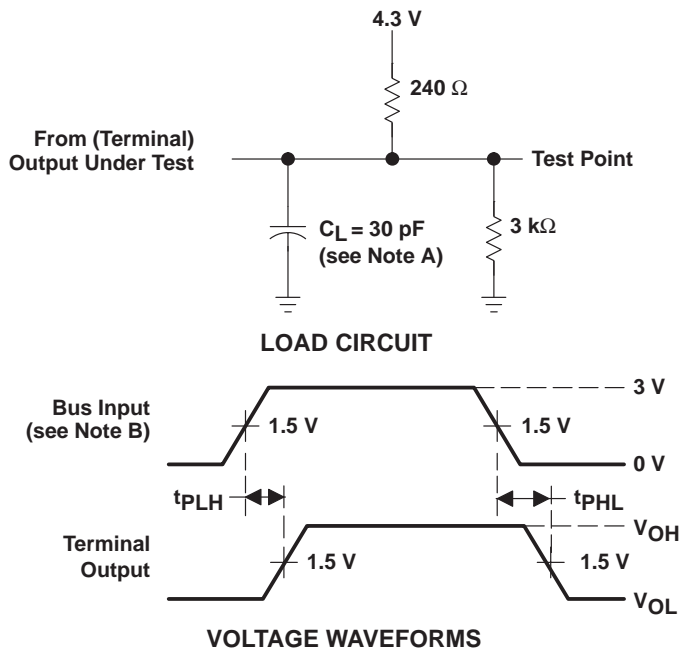

- NOTES: A. C_L includes probe and jig capacitance.
 B. The input pulse is supplied by a generator having the following characteristics: $PRR \leq 1 \text{ MHz}$, 50% duty cycle, $t_r \leq 6 \text{ ns}$, $t_f \leq 6 \text{ ns}$, $Z_O = 50 \Omega$.

Figure 2. Bus-to-Terminal Load Circuit and Voltage Waveforms

SN75ALS161 OCTAL GENERAL-PURPOSE INTERFACE BUS TRANSCEIVERS

SLLS019F – JUNE 1986 – REVISED JULY 2004

PARAMETER MEASUREMENT INFORMATION

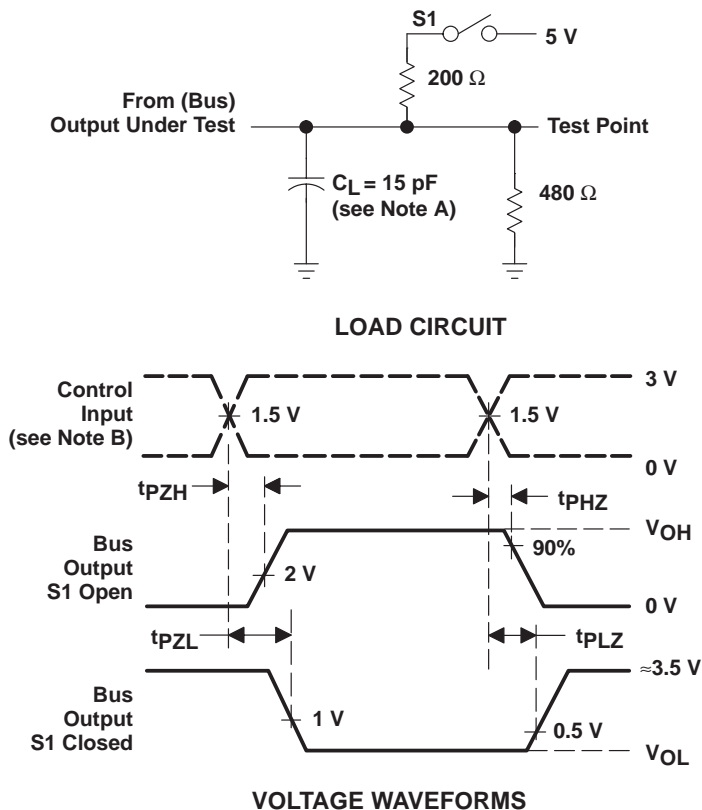

- NOTES: A. C_L includes probe and jig capacitance.
 B. The input pulse is supplied by a generator having the following characteristics: $PRR \leq 1 \text{ MHz}$, 50% duty cycle, $t_r \leq 6 \text{ ns}$, $t_f \leq 6 \text{ ns}$, $Z_O = 50 \Omega$.

Figure 3. Bus Load Circuit and Voltage Waveforms

PARAMETER MEASUREMENT INFORMATION

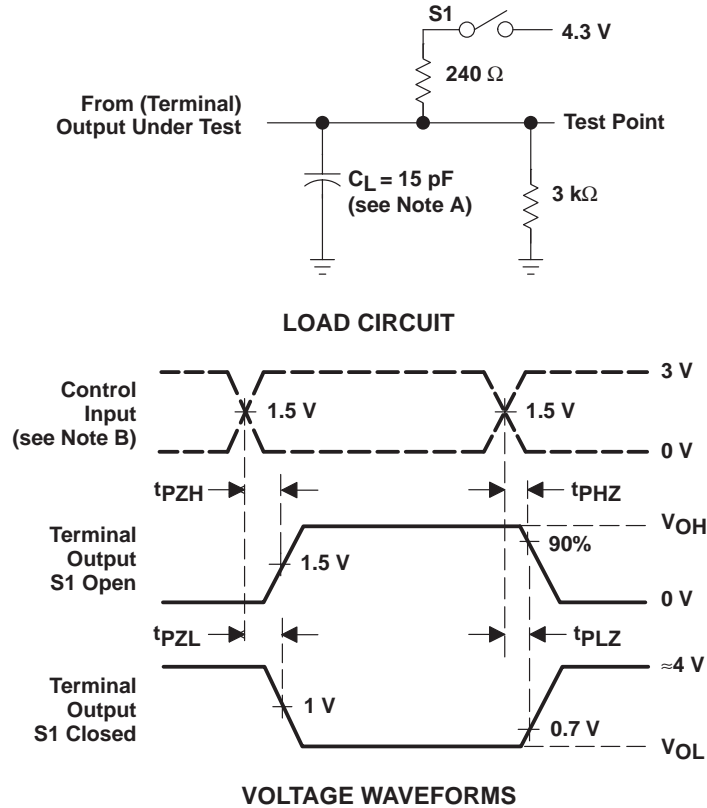

- NOTES: A. C_L includes probe and jig capacitance.
 B. The input pulse is supplied by a generator having the following characteristics: PRR ≤ 1 MHz, 50% duty cycle, t_r ≤ 6 ns, t_f ≤ 6 ns, Z_O = 50 Ω.

Figure 4. Terminal Load Circuit and Voltage Waveforms

SN75ALS161 OCTAL GENERAL-PURPOSE INTERFACE BUS TRANSCEIVERS

SLLS019F – JUNE 1986 – REVISED JULY 2004

TYPICAL CHARACTERISTICS†

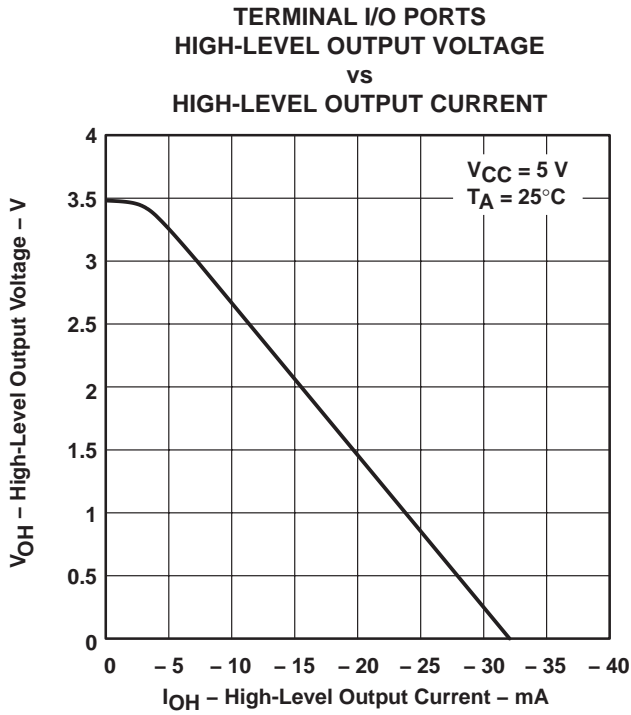

Figure 5

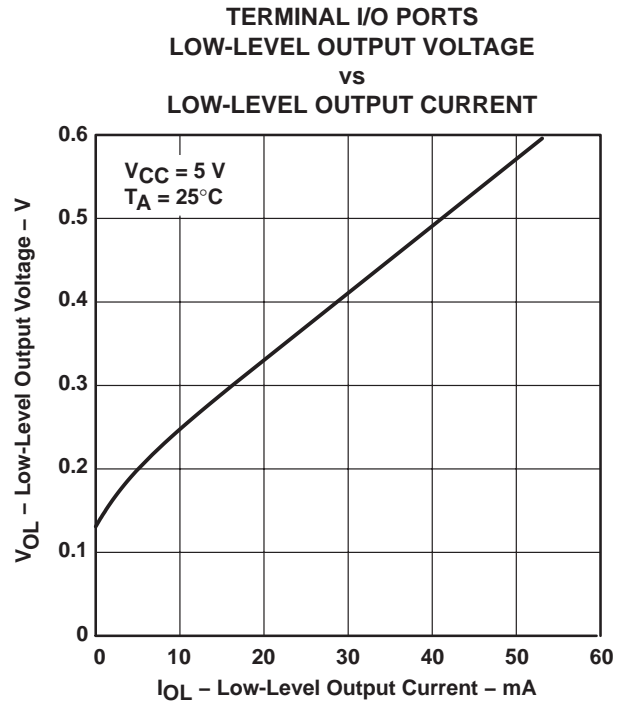

Figure 6

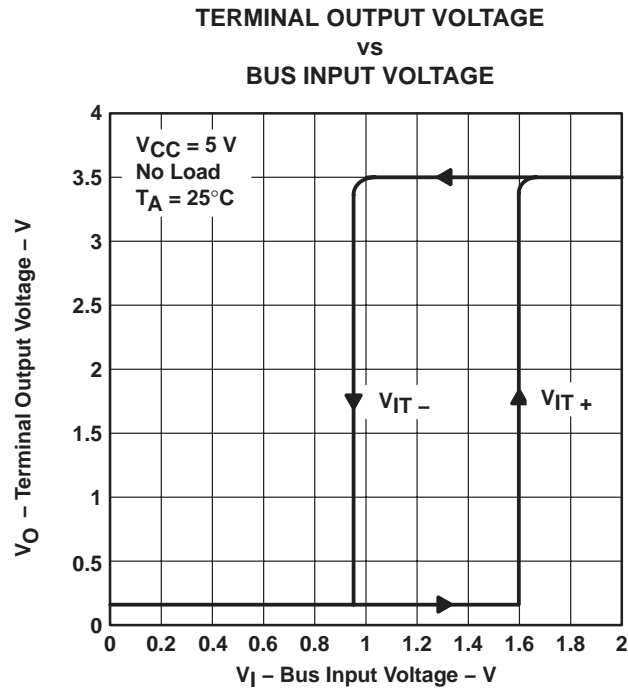

Figure 7

† Operation of the device at these or any other conditions beyond those indicated under "recommended operating conditions" is not implied.

TYPICAL CHARACTERISTICS†

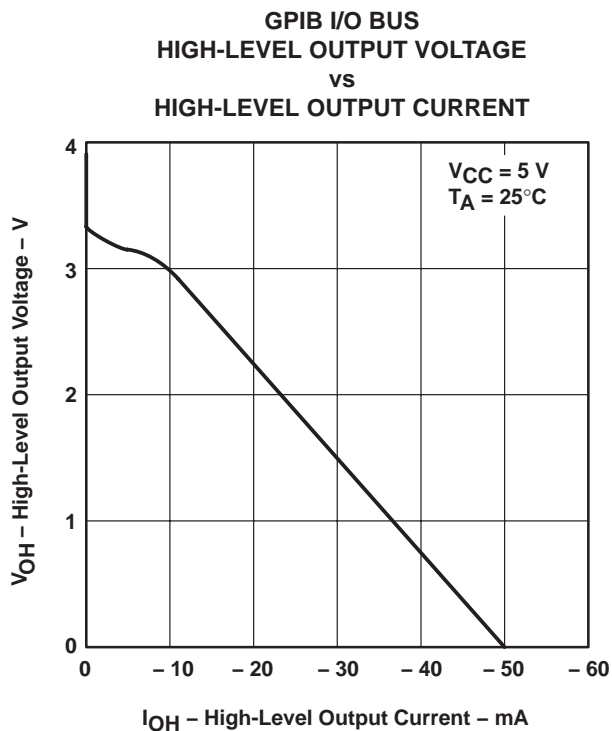

Figure 8

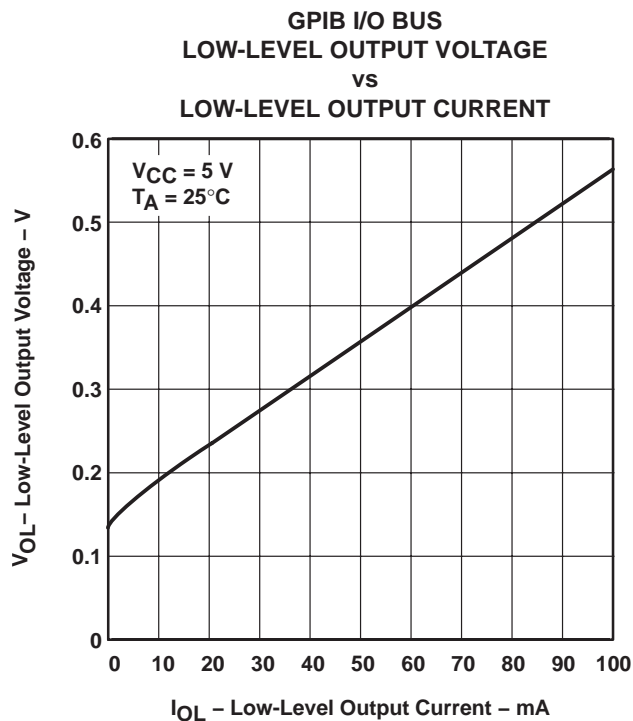

Figure 9

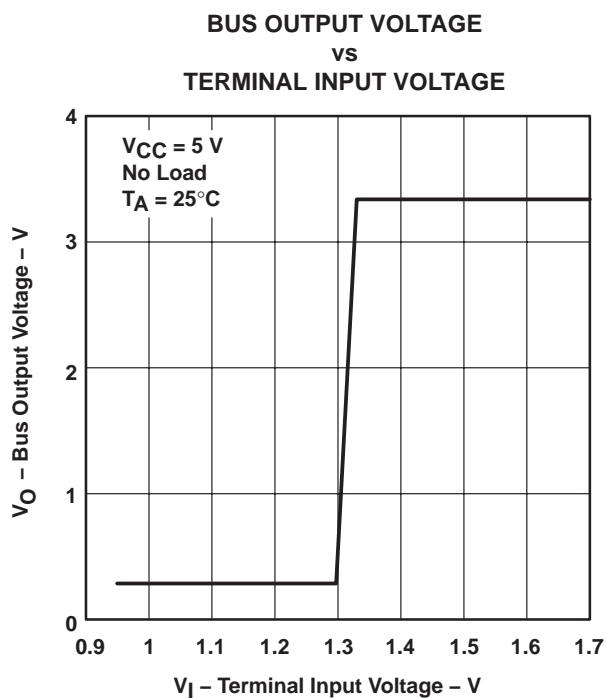

Figure 10

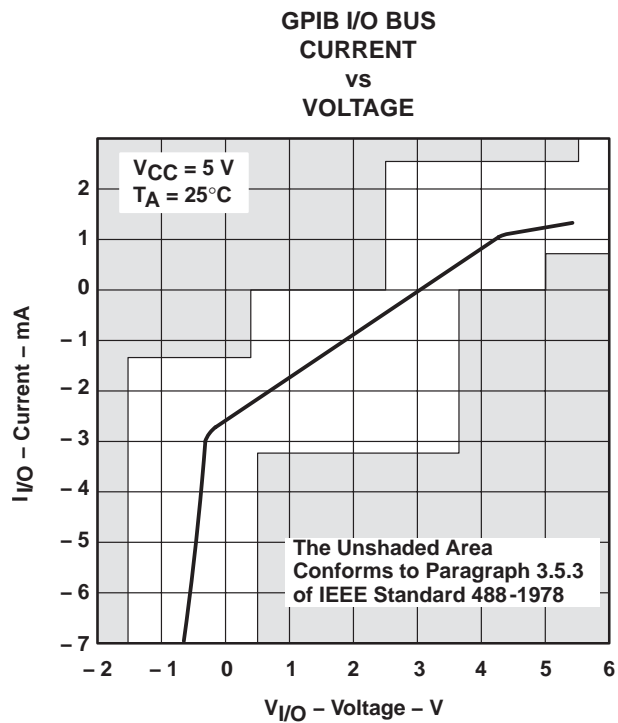

Figure 11

† Operation of the device at these or any other conditions beyond those indicated under "recommended operating conditions" is not implied.

PACKAGING INFORMATION

Orderable part number	Status (1)	Material type (2)	Package Pins	Package qty Carrier	RoHS (3)	Lead finish/ Ball material (4)	MSL rating/ Peak reflow (5)	Op temp (°C)	Part marking (6)
SN75ALS161DW	Active	Production	SOIC (DW) 20	25 TUBE	Yes	NIPDAU	Level-1-260C-UNLIM	0 to 70	75ALS161
SN75ALS161DW.A	Active	Production	SOIC (DW) 20	25 TUBE	Yes	NIPDAU	Level-1-260C-UNLIM	0 to 70	75ALS161
SN75ALS161DWG4	Active	Production	SOIC (DW) 20	25 TUBE	Yes	NIPDAU	Level-1-260C-UNLIM	0 to 70	75ALS161
SN75ALS161DWR	Active	Production	SOIC (DW) 20	2000 LARGE T&R	Yes	NIPDAU	Level-1-260C-UNLIM	0 to 70	75ALS161
SN75ALS161DWR.A	Active	Production	SOIC (DW) 20	2000 LARGE T&R	Yes	NIPDAU	Level-1-260C-UNLIM	0 to 70	75ALS161
SN75ALS161N	Active	Production	PDIP (N) 20	20 TUBE	Yes	NIPDAU	N/A for Pkg Type	0 to 70	SN75ALS161N
SN75ALS161N.A	Active	Production	PDIP (N) 20	20 TUBE	Yes	NIPDAU	N/A for Pkg Type	0 to 70	SN75ALS161N

(1) **Status:** For more details on status, see our [product life cycle](#).

(2) **Material type:** When designated, preproduction parts are prototypes/experimental devices, and are not yet approved or released for full production. Testing and final process, including without limitation quality assurance, reliability performance testing, and/or process qualification, may not yet be complete, and this item is subject to further changes or possible discontinuation. If available for ordering, purchases will be subject to an additional waiver at checkout, and are intended for early internal evaluation purposes only. These items are sold without warranties of any kind.

(3) **RoHS values:** Yes, No, RoHS Exempt. See the [TI RoHS Statement](#) for additional information and value definition.

(4) **Lead finish/Ball material:** Parts may have multiple material finish options. Finish options are separated by a vertical ruled line. Lead finish/Ball material values may wrap to two lines if the finish value exceeds the maximum column width.

(5) **MSL rating/Peak reflow:** The moisture sensitivity level ratings and peak solder (reflow) temperatures. In the event that a part has multiple moisture sensitivity ratings, only the lowest level per JEDEC standards is shown. Refer to the shipping label for the actual reflow temperature that will be used to mount the part to the printed circuit board.

(6) **Part marking:** There may be an additional marking, which relates to the logo, the lot trace code information, or the environmental category of the part.

Multiple part markings will be inside parentheses. Only one part marking contained in parentheses and separated by a "-" will appear on a part. If a line is indented then it is a continuation of the previous line and the two combined represent the entire part marking for that device.

Important Information and Disclaimer: The information provided on this page represents TI's knowledge and belief as of the date that it is provided. TI bases its knowledge and belief on information provided by third parties, and makes no representation or warranty as to the accuracy of such information. Efforts are underway to better integrate information from third parties. TI has taken and continues to take reasonable steps to provide representative and accurate information but may not have conducted destructive testing or chemical analysis on incoming materials and chemicals. TI and TI suppliers consider certain information to be proprietary, and thus CAS numbers and other limited information may not be available for release.

In no event shall TI's liability arising out of such information exceed the total purchase price of the TI part(s) at issue in this document sold by TI to Customer on an annual basis.

OTHER QUALIFIED VERSIONS OF SN75ALS161 :

- Military : [SN55ALS161](#)

NOTE: Qualified Version Definitions:

- Military - QML certified for Military and Defense Applications

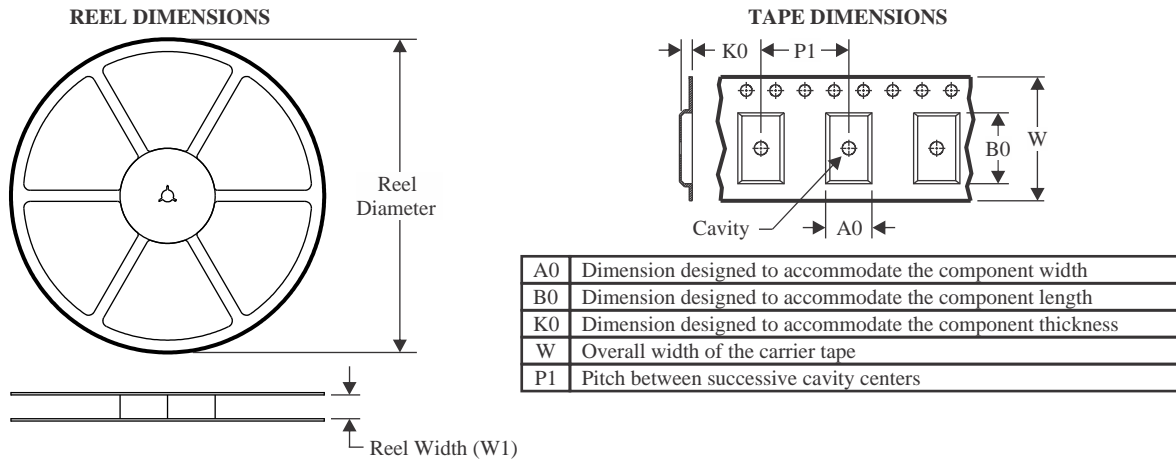
TAPE AND REEL INFORMATION

QUADRANT ASSIGNMENTS FOR PIN 1 ORIENTATION IN TAPE

*All dimensions are nominal

Device	Package Type	Package Drawing	Pins	SPQ	Reel Diameter (mm)	Reel Width W1 (mm)	A0 (mm)	B0 (mm)	K0 (mm)	P1 (mm)	W (mm)	Pin1 Quadrant
SN75ALS161DWR	SOIC	DW	20	2000	330.0	24.4	10.8	13.3	2.7	12.0	24.0	Q1

TAPE AND REEL BOX DIMENSIONS

*All dimensions are nominal

Device	Package Type	Package Drawing	Pins	SPQ	Length (mm)	Width (mm)	Height (mm)
SN75ALS161DWR	SOIC	DW	20	2000	350.0	350.0	43.0

TUBE

*All dimensions are nominal

Device	Package Name	Package Type	Pins	SPQ	L (mm)	W (mm)	T (μm)	B (mm)
SN75ALS161DW	DW	SOIC	20	25	506.98	12.7	4826	6.6
SN75ALS161DW.A	DW	SOIC	20	25	506.98	12.7	4826	6.6
SN75ALS161DWG4	DW	SOIC	20	25	506.98	12.7	4826	6.6
SN75ALS161N	N	PDIP	20	20	506	13.97	11230	4.32
SN75ALS161N.A	N	PDIP	20	20	506	13.97	11230	4.32

N (R-PDIP-T**)

PLASTIC DUAL-IN-LINE PACKAGE

16 PINS SHOWN



- NOTES:
- A. All linear dimensions are in inches (millimeters).
 - B. This drawing is subject to change without notice.
 - Falls within JEDEC MS-001, except 18 and 20 pin minimum body length (Dim A).
 - The 20 pin end lead shoulder width is a vendor option, either half or full width.

DW0020A



PACKAGE OUTLINE

SOIC - 2.65 mm max height

SOIC



4220724/A 05/2016

NOTES:

1. All linear dimensions are in millimeters. Dimensions in parenthesis are for reference only. Dimensioning and tolerancing per ASME Y14.5M.
2. This drawing is subject to change without notice.
3. This dimension does not include mold flash, protrusions, or gate burrs. Mold flash, protrusions, or gate burrs shall not exceed 0.15 mm per side.
4. This dimension does not include interlead flash. Interlead flash shall not exceed 0.43 mm per side.
5. Reference JEDEC registration MS-013.

EXAMPLE BOARD LAYOUT

DW0020A

SOIC - 2.65 mm max height

SOIC



LAND PATTERN EXAMPLE
SCALE:6X



SOLDER MASK DETAILS

4220724/A 05/2016

NOTES: (continued)

- 6. Publication IPC-7351 may have alternate designs.
- 7. Solder mask tolerances between and around signal pads can vary based on board fabrication site.

EXAMPLE STENCIL DESIGN

DW0020A

SOIC - 2.65 mm max height

SOIC



SOLDER PASTE EXAMPLE
BASED ON 0.125 mm THICK STENCIL
SCALE:6X

4220724/A 05/2016

NOTES: (continued)

8. Laser cutting apertures with trapezoidal walls and rounded corners may offer better paste release. IPC-7525 may have alternate design recommendations.
9. Board assembly site may have different recommendations for stencil design.

IMPORTANT NOTICE AND DISCLAIMER

TI PROVIDES TECHNICAL AND RELIABILITY DATA (INCLUDING DATASHEETS), DESIGN RESOURCES (INCLUDING REFERENCE DESIGNS), APPLICATION OR OTHER DESIGN ADVICE, WEB TOOLS, SAFETY INFORMATION, AND OTHER RESOURCES "AS IS" AND WITH ALL FAULTS, AND DISCLAIMS ALL WARRANTIES, EXPRESS AND IMPLIED, INCLUDING WITHOUT LIMITATION ANY IMPLIED WARRANTIES OF MERCHANTABILITY, FITNESS FOR A PARTICULAR PURPOSE OR NON-INFRINGEMENT OF THIRD PARTY INTELLECTUAL PROPERTY RIGHTS.

These resources are intended for skilled developers designing with TI products. You are solely responsible for (1) selecting the appropriate TI products for your application, (2) designing, validating and testing your application, and (3) ensuring your application meets applicable standards, and any other safety, security, regulatory or other requirements.

These resources are subject to change without notice. TI grants you permission to use these resources only for development of an application that uses the TI products described in the resource. Other reproduction and display of these resources is prohibited. No license is granted to any other TI intellectual property right or to any third party intellectual property right. TI disclaims responsibility for, and you fully indemnify TI and its representatives against any claims, damages, costs, losses, and liabilities arising out of your use of these resources.

TI's products are provided subject to [TI's Terms of Sale](#), [TI's General Quality Guidelines](#), or other applicable terms available either on ti.com or provided in conjunction with such TI products. TI's provision of these resources does not expand or otherwise alter TI's applicable warranties or warranty disclaimers for TI products. Unless TI explicitly designates a product as custom or customer-specified, TI products are standard, catalog, general purpose devices.

TI objects to and rejects any additional or different terms you may propose.

Copyright © 2026, Texas Instruments Incorporated

Last updated 10/2025