

TLx84x 電流モード PWM コントローラ

1 特長

- オフラインおよび DC-DC コンバータ用に最適化
- 低いスタートアップ電流 (1mA 未満)
- 自動フィードフォワード補償
- パルス単位の電流制限
- 拡張された負荷応答特性
- ヒステリシス付きの低電圧誤動作防止
- ダブル パルス抑制
- 大電流トータムポール出力
- 内部トリムされたバンドギャップ リファレンス
- 500kHz 動作
- 出力抵抗の低いエラー アンプ
- UC2842 および UC3842 シリーズと交換可能

2 アプリケーション

- あらゆる極性のスイッチング レギュレータ
- トランス結合型 DC/DC コンバータ

3 概要

TL284x および TL384x シリーズの制御 IC には、オフラインや DC-DC 固定周波数の電流モード制御スキーマを最小限の外付け部品で実装するために必要な機能が搭載されています。内蔵回路には、低電圧誤動作防止 (UVLO) 回路、1mA 未満の電流で起動する起動回路、エラー アンプ入力の精度を高めるために調整された高精度リファレンスが含まれます。それ以外にも、ラッチ動作を保証するロジック、パルス幅変調 (PWM) コンパレータ (電流制限制御の機能も兼ねています)、大きなピーク電流をソースまたはシンクするように設計されたトータムポール出力段が内蔵されています。出力段は N チャネル MOSFET の駆動に適しており、オフ状態のとき Low です。

パッケージ情報

部品番号	パッケージ (1)	パッケージ サイズ(2)
TLx84x	D (SOIC, 8)	4.90mm × 6.00 mm
	D (SOIC, 14)	8.65mm × 6.00 mm
	P (PDIP, 8)	9.81mm × 9.43 mm

- (1) 利用可能なすべてのパッケージについては、データシートの末尾にある注文情報を参照してください。
- (2) パッケージ サイズ (長さ × 幅) は公称値であり、該当する場合はピンも含まれます。

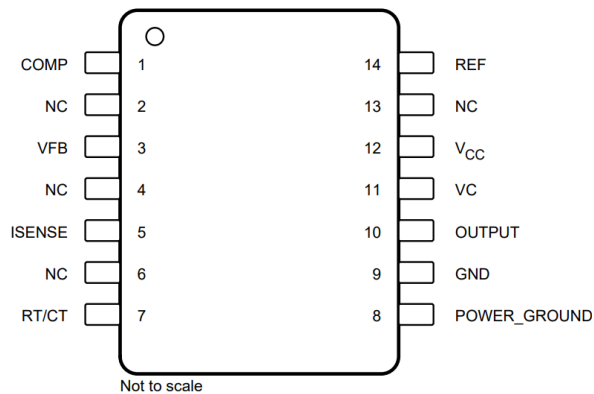

D パッケージ 14 ピン SOIC 上面図

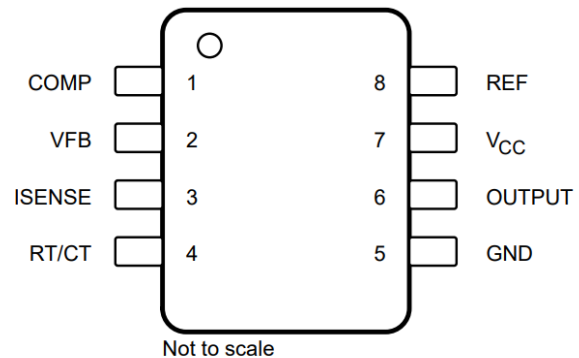

NC — No internal connection

D または P パッケージ 8 ピン SOIC または PDIP 上面



Table of Contents

1 特長	1	6.4 Device Functional Modes.....	9
2 アプリケーション	1	7 Application and Implementation	10
3 概要	1	7.1 Typical Application.....	10
4 Pin Configuration and Functions	3	7.2 Power Supply Recommendations.....	12
5 Specifications	4	7.3 Layout.....	12
5.1 Absolute Maximum Ratings.....	4	8 Device and Documentation Support	14
5.2 ESD Ratings.....	4	8.1 ドキュメントの更新通知を受け取る方法.....	14
5.3 Recommended Operating Conditions.....	4	8.2 サポート・リソース.....	14
5.4 Thermal Information.....	4	8.3 Trademarks.....	14
5.5 Electrical Characteristics.....	5	8.4 静電気放電に関する注意事項.....	14
5.6 Typical Characteristics.....	6	8.5 用語集.....	14
6 Detailed Description	8	9 Revision History	14
6.1 Overview.....	8	10 Mechanical, Packaging, and Orderable Information	15
6.2 Functional Block Diagram.....	8		
6.3 Feature Description.....	8		

4 Pin Configuration and Functions



図 4-1. D Package 14-Pin SOIC Top View



NC — No internal connection

図 4-2. D or P Package 8-Pin SOIC or PDIP Top View

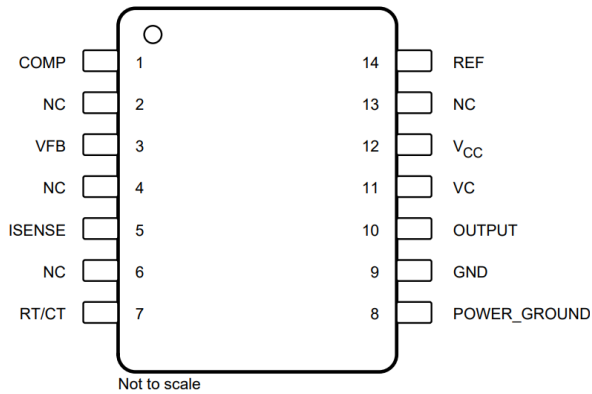
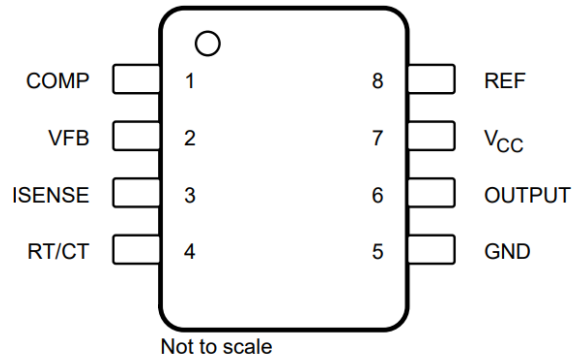
表 4-1. Pin Functions

NAME	PIN		TYPE ⁽¹⁾	DESCRIPTION
	D	D or P		
COMP	1	1	I/O	Error amplifier compensation pin
GND	9	5	—	Device power supply ground terminal
ISENSE	5	3	I	Current sense comparator input
NC	2, 4, 6, 13	—	—	Do not connect
OUTPUT	10	6	O	PWM Output
POWER GROUND	8	—	—	Output PWM ground terminal
REF	14	8	O	Oscillator voltage reference
RT/CT	7	4	I/O	Oscillator RC input
VC	11	—	—	Output PWM positive voltage supply
V _{CC}	12	7	—	Device positive voltage supply
VFB	3	2	I	Error amplifier input

(1) I = Input; O = Output; I/O = Input or Output

5 Specifications

5.1 Absolute Maximum Ratings

over operating free-air temperature range (unless otherwise noted)⁽¹⁾

		MIN	MAX	UNIT
V _{CC}	Supply Voltage ⁽²⁾	Self limiting		—
V _I	Analog input voltage range, VFB and ISENSE	-0.3	6.3	V
V _O	Output Voltage		35	V
V _I	Input Voltage, VC and D Package only		35	V
I _{CC}	Supply current		30	mA
I _O	Output current		±1	A
	error amplifier output sink current		10	mA
T _J	Virtual junction temperature		150	°C
	Output energy (capacitive load)		5	μJ
T _{stg}	Storage temperature	-65	150	°C

(1) Operation outside the *Absolute Maximum Ratings* may cause permanent device damage. *Absolute Maximum Ratings* do not imply functional operation of the device at these or any other conditions beyond those listed under *Recommended Operating Conditions*. If used outside the *Recommended Operating Conditions* but within the *Absolute Maximum Ratings*, the device may not be fully functional, and this may affect device reliability, functionality, performance, and shorten the device lifetime.

(2) All voltages are with respect to the device GND pin.

5.2 ESD Ratings

		VALUE	UNIT
V _(ESD)	Electrostatic discharge	Human body model (HBM), per ANSI/ESDA/JEDEC JS-001, all pins ⁽¹⁾	±3000
		Charged device model (CDM), per JEDEC specification JESD22-C101, all pins ⁽²⁾	±2000

(1) JEDEC document JEP155 states that 500-V HBM allows safe manufacturing with a standard ESD control process.

(2) JEDEC document JEP157 states that 250-V CDM allows safe manufacturing with a standard ESD control process.

5.3 Recommended Operating Conditions

over operating free-air temperature range (unless otherwise noted)

		MIN	TYP	MAX	UNIT
V _{CC} and VC ⁽¹⁾	Supply Voltage			30	V
V _I , RT/CT	Input Voltage	0		5.5	V
V _I , VFB and ISENSE	Input Voltage	0		5.5	V
V _O , OUTPUT	Output voltage	0		30	V
V _O , POWER GROUND ⁽¹⁾	Output voltage	-0.1		1	V
I _{CC}	Supply current, externally limited			25	mA
I _O	Average output current			200	mA
I _{O(ref)}	Reference output current			-20	mA
f _{OSC}	Oscillator frequency		100	500	kHz
T _A	Operating free-air temperature	TL284x		85	°C
		TL384x	-40	70	

(1) These recommended voltages for VC and POWER GROUND apply only to the D package.

5.4 Thermal Information

THERMAL METRIC ⁽¹⁾	TLx84x			UNIT	
	D (SOIC)	D (SOIC)	P (PDIP)		
	8 PINS	14 PINS	8 PINS		
R _{θJA}	Junction-to-ambient thermal resistance	117.4	87.9	74.1	°C/W

(1) For more information about traditional and new thermal metrics, see the [Semiconductor and IC Package Thermal Metrics](#) application note.

5.5 Electrical Characteristics

over operating free-air temperature range, $V_{CC} = 15\text{ V}^{(1)}$, $R_T = 10\text{ k}\Omega$, $C_T = 3.3\text{ nF}$ (unless otherwise noted)

PARAMETER	TEST CONDITIONS ⁽²⁾	TL284x			TL384x			UNIT
		MIN	TYP ⁽²⁾	MAX	MIN	TYP ⁽²⁾	MAX	
Reference Section								
Output voltage	$I_O = 1\text{ mA}$, $T_A = 25^\circ\text{C}$	4.95	5	5.05	4.9	5	5.1	V
Line regulation	$V_{CC} = 12\text{ V to }25\text{ V}$		6	20		6	20	mV
Load regulation	$I_O = 1\text{ mA to }20\text{ mA}$		6	25		6	25	mV
Temperature coefficient of output voltage			0.2	0.4		0.2	0.4	mV/°C
Output voltage with worst-case variation	$V_{CC} = 12\text{ V to }25\text{ V}$, $I_O = 1\text{ mA to }20\text{ mA}$	4.9		5.1	4.82		5.18	V
Output noise voltage	$f = 10\text{ Hz to }10\text{ kHz}$, $T_A = 25^\circ\text{C}$		50			50		μV
Output-voltage long-term drift	After 1000 h at $T_A = 25^\circ\text{C}$		5	25		5	25	mV
Short-circuit output current		-30	-100	-180	-30	-100	-180	mA
Oscillator Section								
Oscillator frequency ⁽³⁾	$T_A = 25^\circ\text{C}$	47	52	57	47	52	57	kHz
Frequency change with supply voltage	$V_{CC} = 12\text{ V to }25\text{ V}$		2	10		2	10	Hz/kHz
Frequency change with temperature			50			50		Hz/kHz
peak-to-peak amplitude at RT/CT			1.7			1.7		V
Error-Amplifier Section								
Feedback input voltage	COMP at 2.5 V	2.45	2.50	2.55	2.42	2.50	2.58	V
Input bias current			-0.3	-1		-0.3	-2	μA
Open-loop voltage amplification	$V_O = 2\text{ V to }4\text{ V}$	65	90		65	90		dB
Gain-bandwidth product		0.7	1		0.7	1		MHz
Supply-voltage rejection ratio	$V_{CC} = 12\text{ V to }25\text{ V}$	60	70		60	70		dB
Output sink current	VFB, at 2.7 V, COMP at 1.1 V	2	6		2	6		mA
Output source current	VFB, at 2.3 V, COMP at 5 V	-0.5	-0.8		-0.5	-0.8		mA
High-level output voltage	VFB, at 2.3 V, $R_L = 15\text{ k}\Omega$ to GND	5	6		5	6		V
Low-level output voltage	VFB, at 2.7 V, $R_L = 15\text{ k}\Omega$ to GND		0.7	1.1		0.7	1.1	V
Current-sense Section								
Voltage amplification	See ⁽⁴⁾ ⁽⁵⁾	2.85	3	3.13	2.85	3	3.15	V/V
Current-sense comparator threshold	COMP at 5 V, see ⁽⁴⁾	0.9	1	1.1	0.9	1	1.1	V
Supply-voltage rejection ratio	$V_{CC} = 12\text{ V to }25\text{ V}$, see ⁽⁴⁾		70			70		dB
Input bias current			-2	-10		-2	-10	μA
Delay time to output			150	300		150	300	ns
Output Section								
High-level output voltage	$I_{OH} = -20\text{ mA}$	13	13.5		13	13.5		V
	$I_{OH} = -200\text{ mA}$	12	13.5		13	13.5		
Low-level output voltage	$I_{OH} = 20\text{ mA}$		0.1	0.4		0.1	0.4	V
	$I_{OH} = 200\text{ mA}$		1.5	2.2		1.5	2.2	
Rise time	$C_L = 1\text{ nF}$, $T_A = 25^\circ\text{C}$		25	150		25	150	ns
fall time	$C_L = 1\text{ nF}$, $T_A = 25^\circ\text{C}$		25	150		25	150	ns
Undervoltage-Lockout Section								
Start threshold voltage	TLx842, TLx844	15	16	17	14.5	16	17.5	V
	TLx843, TLx845	7.8	8.4	9	7.8	8.4	9	
Minimum operating voltage after startup	TLx842, TLx844	9	10	11	8.5	10	11.5	V
	TLx843, TLx845	7	7.6	8.2	7	7.6	8.02	
Pulse-Width-Modulator Section								

5.5 Electrical Characteristics (続き)

over operating free-air temperature range, $V_{CC} = 15\text{ V}^{(1)}$, $R_T = 10\text{ k}\Omega$, $C_T = 3.3\text{ nF}$ (unless otherwise noted)

PARAMETER	TEST CONDITIONS ⁽²⁾	TL284x			TL384x			UNIT
		MIN	TYP ⁽²⁾	MAX	MIN	TYP ⁽²⁾	MAX	
Maximum duty cycle	TLx842, TLx843	92%	97%	100%	92%	97%	100%	
	TLx844, TLx845	46%	48%	50%	46%	48%	50%	
Minimum duty cycle				0%			0%	
Supply Voltage								
Start-up current			0.5	1		0.5	1	mA
Operating supply current	VFB and ISENSE at 0 V		11	17		11	17	mA
Limiting voltage	$I_{CC} = 25\text{ mA}$		39			39		V

- (1) Adjust V_{CC} above the start threshold before setting it to 15 V.
- (2) All typical values are at $T_A = 25^\circ\text{C}$.
- (3) Output frequency equals oscillator frequency for the TLx842 and TLx843. Output frequency is one-half the oscillator frequency for the TLx844 and TLx845.
- (4) These parameters are measured at the trip point of the latch, with VFB at 0 V.
- (5) Voltage amplification is measured between ISENSE and COMP, with the input changing from 0 V to 0.8 V.

5.6 Typical Characteristics



図 5-1. Oscillator Discharge Current vs Temperature for $V_{IN} = 15\text{ V}$ and $V_{OSC} = 2\text{ V}$



図 5-2. Current Sense Input Threshold vs Error Amplifier Output Voltage for $V_{IN} = 15\text{ V}$

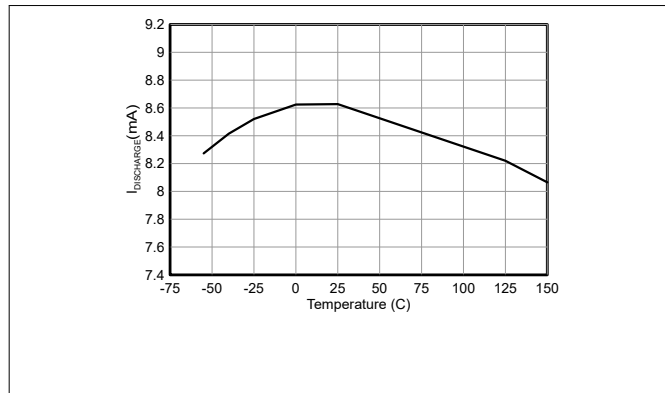

図 5-3. Error Amplifier Open-Loop Gain and Phase vs Frequency $V_{CC} = 15\text{ V}$, $R_L = 100\text{ k}\Omega$, and $T_A = 25^\circ\text{C}$

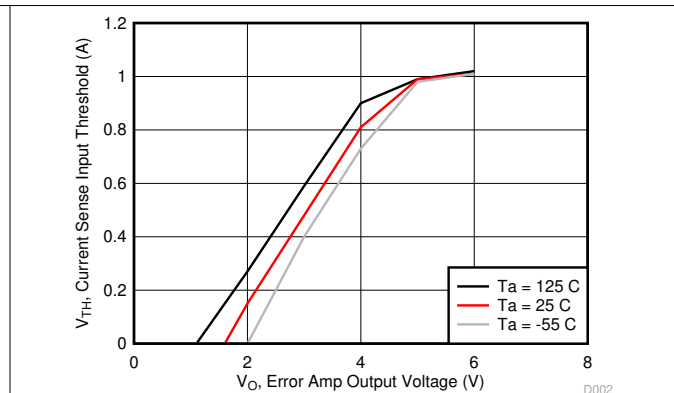

図 5-4. Max Output Duty Cycle vs Timing Resistor for $V_{CC} = 15$, $C_T = 3.3\text{ nF}$, $T_A = 25^\circ\text{C}$

5.6 Typical Characteristics (continued)

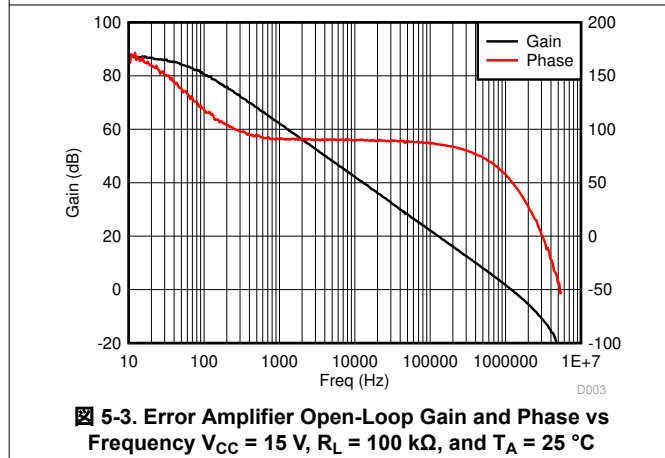

图 5-5. Output Saturation Voltage vs Load Current for $V_{CC} = 15$ V with 5-ms Input Pulses

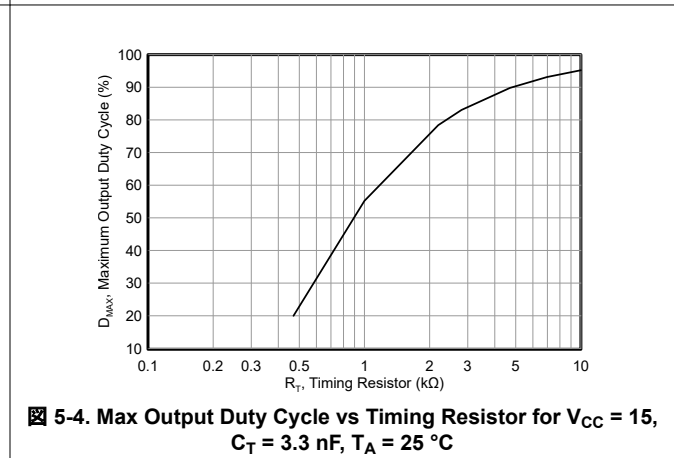

图 5-6. Reference Short Circuit Current vs Temperature for $V_{IN} = 15$ V

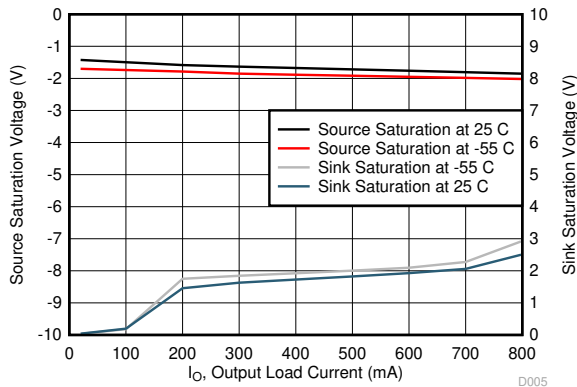

图 5-7. Reference Voltage vs Source Current

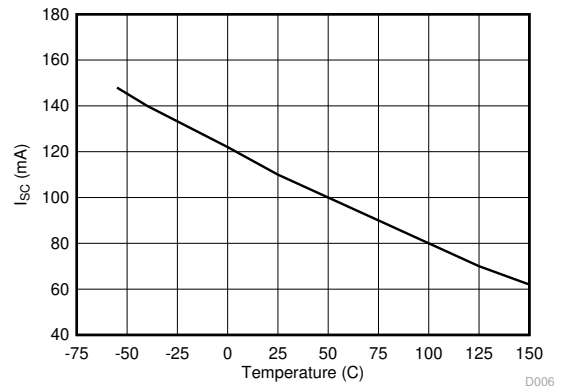

图 5-8. Reference Voltage vs Temperature

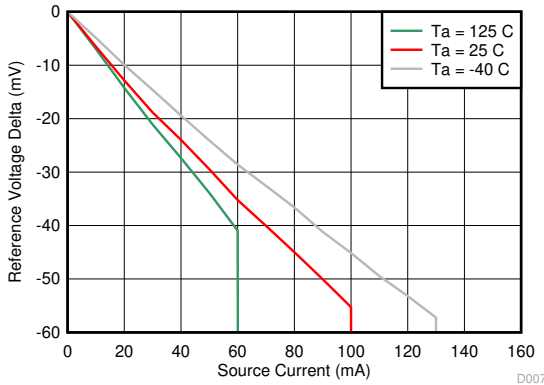

图 5-9. Dead Time vs Timing Capacitance

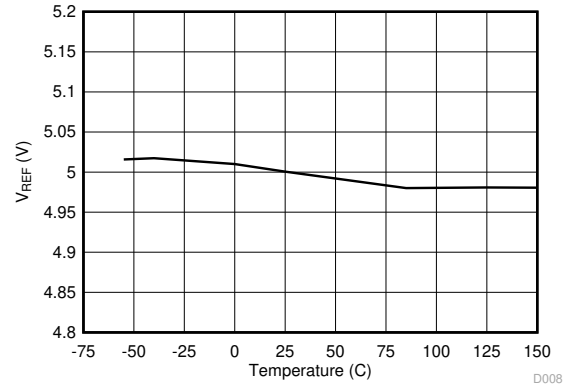

图 5-10. Timing Resistance vs Frequency

6 Detailed Description

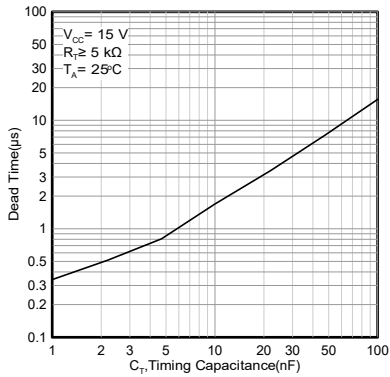
6.1 Overview

The TL284x and TL384x series of control integrated circuits provide the features that are necessary to implement off-line or DC-to-DC fixed-frequency current-mode control schemes, with a minimum number of external components. Some of the internally implemented circuits are an undervoltage lockout (UVLO), featuring a start-up current of less than 1 mA, and a precision reference trimmed for accuracy at the error amplifier input. Other internal circuits include logic to ensure latched operation, a pulse-width modulation (PWM) comparator (that also provides current-limit control), and a totem-pole output stage designed to source or sink high-peak current. The output stage, suitable for driving N-channel MOSFETs, is low when it is in the off state.

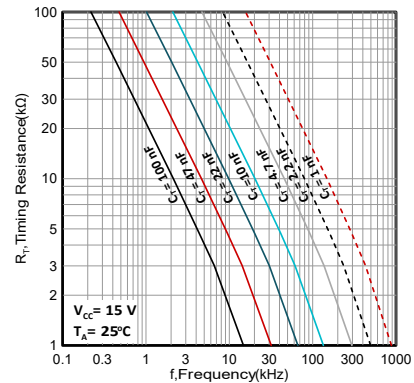
Major differences between members of these series are the UVLO thresholds and maximum duty-cycle ranges. Typical UVLO thresholds of 16 V (on) and 10 V (off) on the TLx842 and TLx844 devices make them ideally suited to off-line applications. The corresponding typical thresholds for the TLx843 and TLx845 devices are 8.4 V (on) and 7.6 V (off). The TLx842 and TLx843 devices can operate to duty cycles approaching 100%. A duty-cycle range of 0 to 50% is obtained by the TLx844 and TLx845 by the addition of an internal toggle flip-flop, which blanks the output off every other clock cycle.

The TL284x-series devices are characterized for operation from -40°C to $+85^{\circ}\text{C}$. The TL384x devices are characterized for operation from 0°C to 70°C .

6.2 Functional Block Diagram

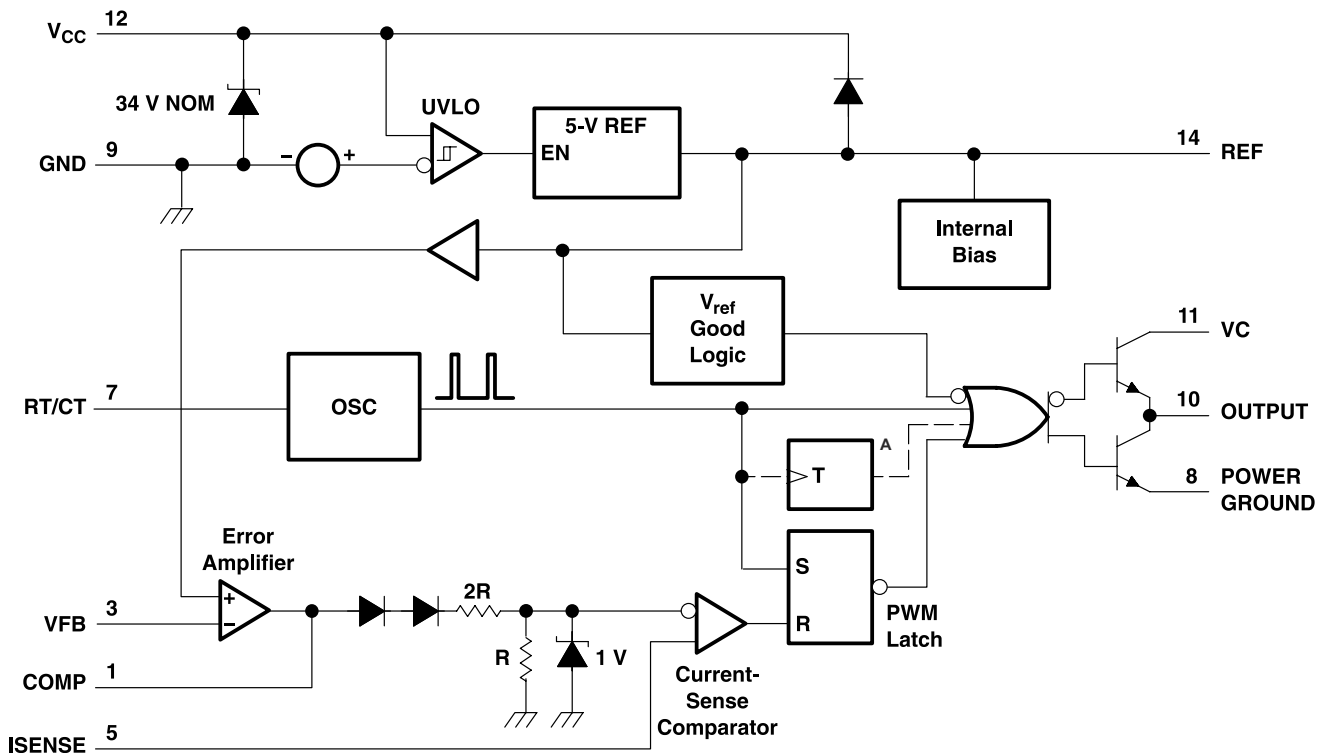

A. The toggle flip-flop is present only in TL2844, TL2845, TL3844, and TL3845. Pin numbers shown are for the D (14-pin) package.

6.3 Feature Description

6.3.1 Pulse-by-Pulse Current Limiting

Pulse-by-pulse limiting is inherent in the control scheme. An upper limit on the peak current can be established by simply clamping the error voltage. Accurate current limiting allows optimization of magnetic and power semiconductor elements while ensuring reliable supply operation.

6.3.2 Error Amplifier With Low Output Resistance

With a low output resistance, various impedance networks may be used on the compensation pin input for error amplifier feedback.

6.3.3 High-Current Totem-Pole Output

The output of the TLx84x devices can sink or source up to 1 A of current.

6.4 Device Functional Modes

6.4.1 Shutdown Technique

The PWM controller (see [Figure 6-1](#)) can be shut down by two methods: either raise the voltage at ISENSE above 1 V or pull the COMP terminal below a voltage two diode drops above ground. Either method causes the output of the PWM comparator to be high (see [Functional Block Diagram](#)). The PWM latch is reset dominant so that the output remains low until the next clock cycle after the shutdown condition at the COMP or ISENSE terminal is removed. In one example, an externally latched shutdown can be accomplished by adding an SCR that resets by cycling VCC below the lower UVLO threshold. At this point, the reference turns off, allowing the SCR to reset.

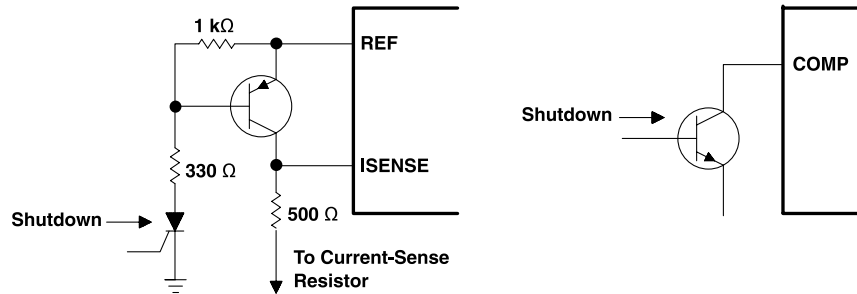

Figure 6-1. Shutdown Techniques

6.4.2 Slope Compensation

A fraction of the oscillator ramp can be summed resistively with the current-sense signal to provide slope compensation for converters requiring duty cycles over 50% (see [Figure 6-2](#)).

注

Capacitor C forms a filter with R2 to suppress the leading-edge switch spikes.

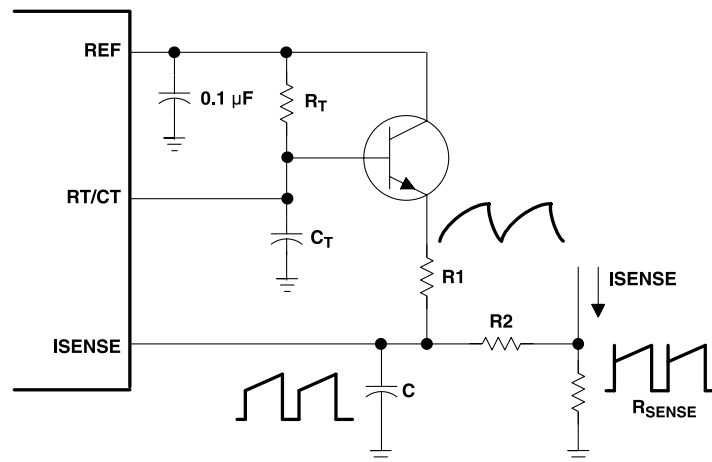

Figure 6-2. Slope Compensation

7 Application and Implementation

注

以下のアプリケーション情報は、TI の製品仕様に含まれるものではなく、TI ではその正確性または完全性を保証いたしません。個々の目的に対する製品の適合性については、お客様の責任で判断していただくこととなります。お客様は自身の設計実装を検証しテストすることで、システムの機能を確認する必要があります。

7.1 Typical Application

The following application is an open-loop laboratory test fixture. This circuit demonstrates the setup and use of the TL284x and TL384x devices and their internal circuitry.

In the open-loop laboratory test fixture (see [図 7-1](#)), high peak currents associated with loads necessitate careful grounding techniques. Timing and bypass capacitors should be connected close to the GND terminal in a single-point ground. The transistor and 5-k Ω potentiometer sample the oscillator waveform and apply an adjustable ramp to the ISENSE terminal.



図 7-1. Open-Loop Laboratory Test Fixture

7.1.1 Design Requirements

The design techniques in the following sections may be used for power supply PWM applications which fall within the following requirements.

- 500-kHz or lower operation
- 30-V or less output voltage
- 200-mA or less output current

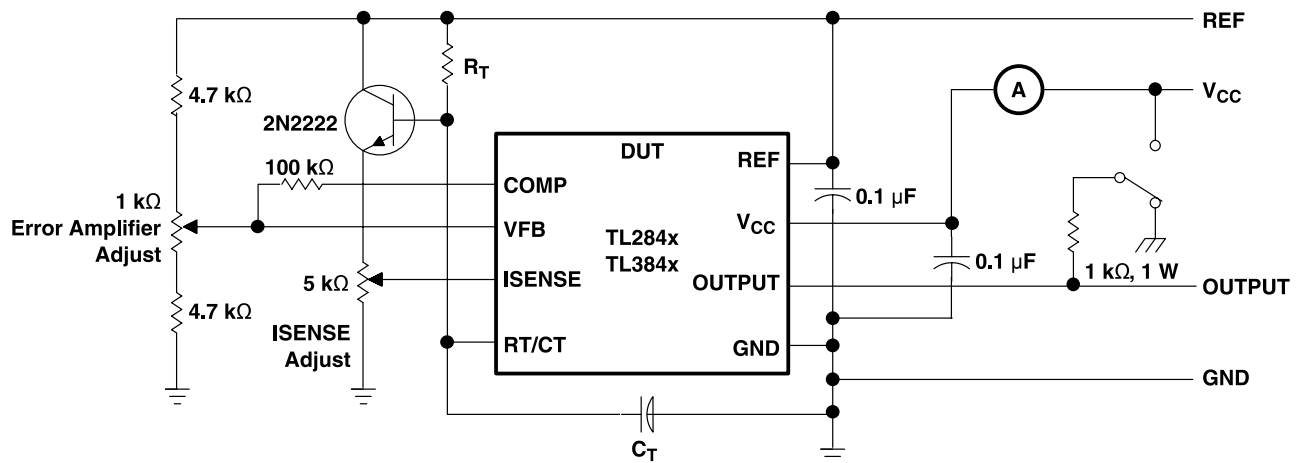
7.1.2 Detailed Design Procedure

7.1.2.1 Current-Sense Circuit

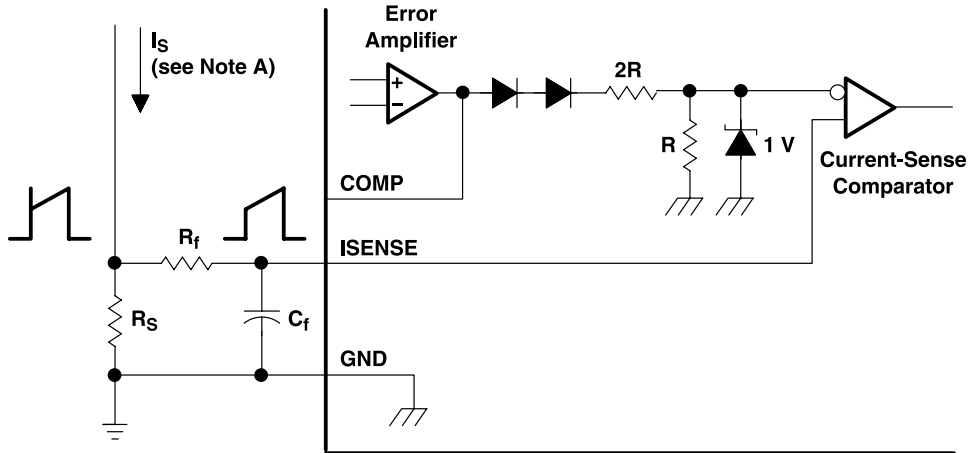

- A. Peak current (I_S) is determined by the formula: $I_{S(max)} = \frac{1V}{R_S}$. A small RC filter formed by resistor R_f and capacitor C_f may be required to suppress switch transients.

図 7-2. Current-Sense Circuit Schematic

7.1.2.2 Error-Amplifier Configuration

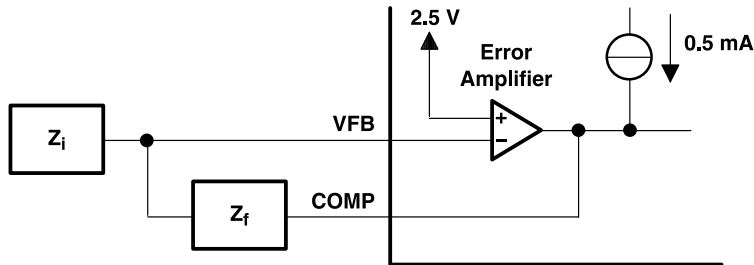

- A. Error amplifier can source or sink up to 0.5 mA.

図 7-3. Error-Amplifier Configuration Schematic

7.1.2.3 Oscillator Section

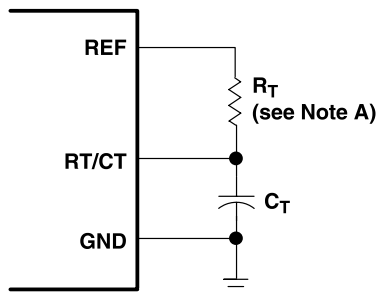

- A. For $R_T > 5 \text{ k}\Omega$: $f \approx \frac{1.72}{R_T C_T}$

図 7-4. Oscillator Section Schematic

7.1.3 Application Curve

The application curve shows oscillator characteristics for chosen capacitor and resistor values.



図 7-5. Supply Current vs Supply Voltage

7.2 Power Supply Recommendations

See [Recommended Operating Conditions](#) for the recommended power supply voltages for the TL284x and TL384x devices. TI also recommends to have a decoupling capacitor on the output of the device's power supply to limit noise on the device input.

7.3 Layout

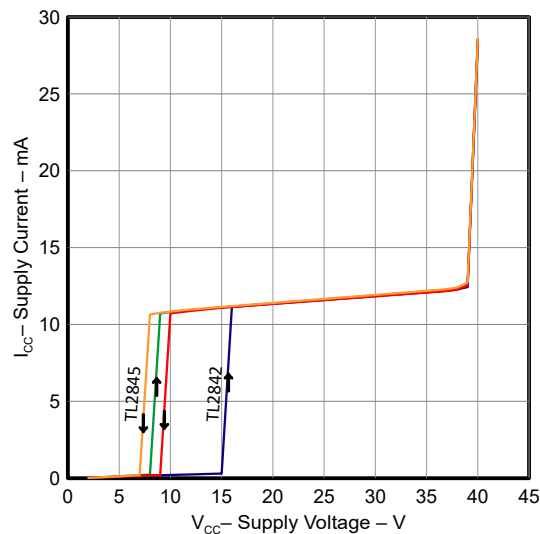
7.3.1 Layout Guidelines

Always try to use a low EMI inductor with a ferrite type closed core. Some examples would be toroid and encased E core inductors. Open core can be used if they have low EMI characteristics and are located a bit more away from the low power traces and components. Make the poles perpendicular to the PCB as well if using an open core. Stick cores usually emit the most unwanted noise.

7.3.1.1 Feedback Traces

Try to run the feedback trace as far from the inductor and noisy power traces as possible. Also, keep the feedback trace to be as direct as possible and somewhat thick. These two sometimes involve a trade-off, but keeping it away from inductor EMI and other noise sources is the more critical of the two. Run the feedback trace on the side of the PCB opposite of the inductor with a ground plane separating the two.

7.3.1.2 Input/Output Capacitors

When using a low value ceramic input filter capacitor, it should be located as close to the V_{CC} pin of the IC as possible. This will eliminate as much trace inductance effects as possible and give the internal IC rail a cleaner voltage supply. Some designs require the use of a feed-forward capacitor connected from the output to the feedback pin as well, usually for stability reasons. In this case it should also be positioned as close to the IC as possible. Using surface mount capacitors also reduces lead length and lessens the chance of noise coupling into the effective antenna created by through-hole components.

7.3.1.3 Compensation Components

External compensation components for stability should also be placed close to the IC. Surface mount components are recommended here as well for the same reasons discussed for the filter capacitors. These should not be located very close to the inductor either.

7.3.1.4 Traces and Ground Planes

Make all of the power (high current) traces as short, direct, and thick as possible. It is good practice on a standard PCB board to make the traces an absolute minimum of 15 mils (0.381 mm) per Ampere. The inductor, output capacitors, and output diode should be as close to each other possible. This helps reduce the EMI radiated by the power traces due to the high switching currents through them. This will also reduce lead inductance and resistance as well, which in turn reduces noise spikes, ringing, and resistive losses that produce voltage errors.

The grounds of the IC, input capacitors, output capacitors, and output diode (if applicable) should be connected close together directly to a ground plane. It would also be a good idea to have a ground plane on both sides of the PCB. This will reduce noise as well by reducing ground loop errors as well as by absorbing more of the EMI radiated by the inductor. For multi-layer boards with more than two layers, a ground plane can be used to separate the power plane (where the power traces and components are) and the signal plane (where the feedback and compensation and components are) for improved performance. On multi-layer boards the use of vias will be required to connect traces and different planes. It is good practice to use one standard via per 200 mA of current if the trace will need to conduct a significant amount of current from one plane to the other.

Arrange the components so that the switching current loops curl in the same direction. Due to the way switching regulators operate, there are two power states. One state when the switch is on and one when the switch is off. During each state there will be a current loop made by the power components that are currently conducting. Place the power components so that during each of the two states the current loop is conducting in the same direction. This prevents magnetic field reversal caused by the traces between the two half-cycles and reduces radiated EMI.

7.3.2 Layout Example



図 7-6. Layout of D-8 or P Package for TLx84x Devices

8 Device and Documentation Support

8.1 ドキュメントの更新通知を受け取る方法

ドキュメントの更新についての通知を受け取るには、www.tij.co.jp のデバイス製品フォルダを開いてください。[通知] をクリックして登録すると、変更されたすべての製品情報に関するダイジェストを毎週受け取ることができます。変更の詳細については、改訂されたドキュメントに含まれている改訂履歴をご覧ください。

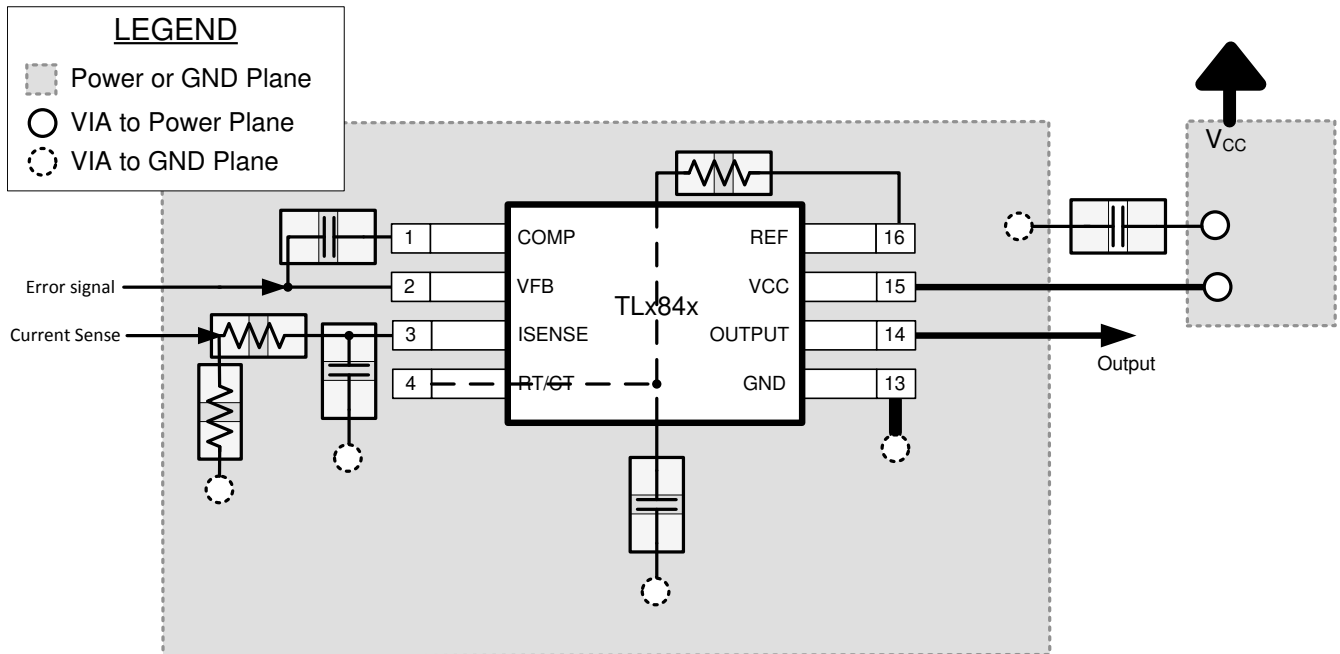
8.2 サポート・リソース

テキサス・インスツルメンツ E2E™ サポート・フォーラムは、エンジニアが検証済みの回答と設計に関するヒントをエキスパートから迅速かつ直接得ることができる場所です。既存の回答を検索したり、独自の質問をしたりすることで、設計に必要な支援を迅速に得ることができます。

リンクされているコンテンツは、各寄稿者により「現状のまま」提供されるものです。これらはテキサス・インスツルメンツの仕様を構成するものではなく、必ずしもテキサス・インスツルメンツの見解を反映したものではありません。テキサス・インスツルメンツの[使用条件](#)を参照してください。

8.3 Trademarks

テキサス・インスツルメンツ E2E™ is a trademark of Texas Instruments.

すべての商標は、それぞれの所有者に帰属します。

8.4 静電気放電に関する注意事項



この IC は、ESD によって破損する可能性があります。テキサス・インスツルメンツは、IC を取り扱う際には常に適切な注意を払うことを推奨します。正しい取り扱いおよび設置手順に従わない場合、デバイスを破損するおそれがあります。

ESD による破損は、わずかな性能低下からデバイスの完全な故障まで多岐にわたります。精密な IC の場合、パラメータがわずかに変化するだけで公表されている仕様から外れる可能性があるため、破損が発生しやすくなっています。

8.5 用語集

[テキサス・インスツルメンツ用語集](#) この用語集には、用語や略語の一覧および定義が記載されています。

9 Revision History

資料番号末尾の英字は改訂を表しています。その改訂履歴は英語版に準じています。

Changes from Revision I (July 2016) to Revision J (October 2024)	Page
• ドキュメント全体にわたって表、図、相互参照の採番方法を更新.....	1
• Changed ESD ratings, CDM rating from $\pm 3000V$ to $\pm 2000V$	4
• Changed thermal information for D-8, D-14, and P-8 packages.....	4
• Changed the OUTPUT SECTION: Rise and fall time, typical value from 50ns to 25ns in the Electrical Characteristics section.....	5
• Changed the PWM: maximum duty cycle of TLx842/3B, minimum value from 95% to 92% in the Electrical Characteristics section.....	5
• Changed the TOTAL STANDBY CURRENT, VCC Zener voltage, typical value from 34V to 39V in the Electrical Characteristics section.....	5
• Updated the <i>Typical Characteristics</i> graphs for $I_{\text{discharge}}$ vs T_a , Maximum Duty Cycle vs R_t , Deadtime vs C_t , R_t vs frequency, and I_{VCC} vs V_{CC}	6

Changes from Revision H (January 2015) to Revision I (July 2016)	Page
• Updated pinout images.....	3
• Changed TL984x to TL384x in <i>Recommended Operating Conditions</i>	4
• Changed TLx842, TLx844 to TLx842, TLx843 and TLx843, TLx845 to TLx844, TLx845 in <i>Pulse-Width-Modulator Section</i>	5

- Added *Receiving Notification of Documentation Updates* section and *Community Resources* section..... 14

Changes from Revision G (February 2008) to Revision H (January 2015)

Page

- 「アプリケーション」、「製品情報」表、「ピンの機能」表、「ESD 定格」表、「熱に関する情報」表、「代表的特性」、「機能説明」セクション、「デバイスの機能モード」、「アプリケーションと実装」セクション、「電源に関する推奨事項」セクション、「レイアウト」セクション、「デバイスおよびドキュメントのサポート」セクション、および「メカニカル、パッケージ、および注文情報」セクションを追加。 1
- 「注文情報」表を削除。 1

10 Mechanical, Packaging, and Orderable Information

The following pages include mechanical, packaging, and orderable information. This information is the most current data available for the designated devices. This data is subject to change without notice and revision of this document. For browser-based versions of this data sheet, refer to the left-hand navigation.

重要なお知らせと免責事項

テキサス・インスツルメンツは、技術データと信頼性データ (データシートを含みます)、設計リソース (リファレンス デザインを含みます)、アプリケーションや設計に関する各種アドバイス、Web ツール、安全性情報、その他のリソースを、欠陥が存在する可能性のある「現状のまま」提供しており、商品性および特定目的に対する適合性の黙示保証、第三者の知的財産権の非侵害保証を含むいかなる保証も、明示的または黙示的にかかわらず拒否します。

これらのリソースは、テキサス・インスツルメンツ製品を使用する設計の経験を積んだ開発者への提供を意図したものです。(1) お客様のアプリケーションに適した テキサス・インスツルメンツ製品の選定、(2) お客様のアプリケーションの設計、検証、試験、(3) お客様のアプリケーションに該当する各種規格や、その他のあらゆる安全性、セキュリティ、規制、または他の要件への確実な適合に関する責任を、お客様のみが単独で負うものとします。

上記の各種リソースは、予告なく変更される可能性があります。これらのリソースは、リソースで説明されている テキサス・インスツルメンツ製品を使用するアプリケーションの開発の目的でのみ、テキサス・インスツルメンツはその使用をお客様に許諾します。これらのリソースに関して、他の目的で複製することや掲載することは禁止されています。テキサス・インスツルメンツや第三者の知的財産権のライセンスが付与されている訳ではありません。お客様は、これらのリソースを自身で使用した結果発生するあらゆる申し立て、損害、費用、損失、責任について、テキサス・インスツルメンツおよびその代理人を完全に補償するものとし、テキサス・インスツルメンツは一切の責任を拒否します。

テキサス・インスツルメンツの製品は、[テキサス・インスツルメンツの販売条件](#)、または [ti.com](https://www.ti.com) やかかる テキサス・インスツルメンツ製品の関連資料などのいずれかを通じて提供する適用可能な条項の下で提供されています。テキサス・インスツルメンツがこれらのリソースを提供することは、適用されるテキサス・インスツルメンツの保証または他の保証の放棄の拡大や変更を意味するものではありません。

お客様がいかなる追加条項または代替条項を提案した場合でも、テキサス・インスツルメンツはそれらに異議を唱え、拒否します。

郵送先住所: Texas Instruments, Post Office Box 655303, Dallas, Texas 75265

Copyright © 2024, Texas Instruments Incorporated

PACKAGING INFORMATION

Orderable part number	Status (1)	Material type (2)	Package Pins	Package qty Carrier	RoHS (3)	Lead finish/ Ball material (4)	MSL rating/ Peak reflow (5)	Op temp (°C)	Part marking (6)
TL2842D	Obsolete	Production	SOIC (D) 14	-	-	Call TI	Call TI	-40 to 85	TL2842
TL2842D-8	Obsolete	Production	SOIC (D) 8	-	-	Call TI	Call TI	-40 to 85	TL2842
TL2842DR	Active	Production	SOIC (D) 14	2500 LARGE T&R	Yes	NIPDAU	Level-2-260C-1 YEAR	-40 to 85	TL2842
TL2842DR-8	Active	Production	SOIC (D) 8	2500 LARGE T&R	Yes	NIPDAU	Level-2-260C-1 YEAR	-40 to 85	TL2842
TL2842DR-8.A	Active	Production	SOIC (D) 8	2500 LARGE T&R	Yes	NIPDAU	Level-2-260C-1 YEAR	-40 to 85	TL2842
TL2842DR.A	Active	Production	SOIC (D) 14	2500 LARGE T&R	Yes	NIPDAU	Level-2-260C-1 YEAR	-40 to 85	TL2842
TL2842P	NRND	Production	PDIP (P) 8	50 TUBE	Yes	NIPDAU	N/A for Pkg Type	-40 to 85	TL2842P
TL2842P.A	NRND	Production	PDIP (P) 8	50 TUBE	Yes	NIPDAU	N/A for Pkg Type	-40 to 85	TL2842P
TL2843D-8	Obsolete	Production	SOIC (D) 8	-	-	Call TI	Call TI	-40 to 85	TL2843
TL2843DR	Active	Production	SOIC (D) 14	2500 LARGE T&R	Yes	NIPDAU	Level-1-260C-UNLIM	-40 to 85	TL2843
TL2843DR-8	Active	Production	SOIC (D) 8	2500 LARGE T&R	Yes	NIPDAU	Level-1-260C-UNLIM	-40 to 85	TL2843
TL2843DR-8.A	Active	Production	SOIC (D) 8	2500 LARGE T&R	Yes	NIPDAU	Level-1-260C-UNLIM	-40 to 85	TL2843
TL2843DR.A	Active	Production	SOIC (D) 14	2500 LARGE T&R	Yes	NIPDAU	Level-1-260C-UNLIM	-40 to 85	TL2843
TL2843DRE4	Active	Production	SOIC (D) 14	2500 LARGE T&R	Yes	NIPDAU	Level-1-260C-UNLIM	-40 to 85	TL2843
TL2843DRG4-8	Active	Production	SOIC (D) 8	2500 LARGE T&R	Yes	NIPDAU	Level-1-260C-UNLIM	-40 to 85	TL2843
TL2843P	Active	Production	PDIP (P) 8	50 TUBE	Yes	NIPDAU	N/A for Pkg Type	-40 to 85	TL2843P
TL2843P.A	Active	Production	PDIP (P) 8	50 TUBE	Yes	NIPDAU	N/A for Pkg Type	-40 to 85	TL2843P
TL2844D	Obsolete	Production	SOIC (D) 14	-	-	Call TI	Call TI	-40 to 85	TL2844
TL2844D-8	Obsolete	Production	SOIC (D) 8	-	-	Call TI	Call TI	-40 to 85	TL2844
TL2844DR	Active	Production	SOIC (D) 14	2500 LARGE T&R	Yes	NIPDAU	Level-1-260C-UNLIM	-40 to 85	TL2844
TL2844DR-8	Active	Production	SOIC (D) 8	2500 LARGE T&R	Yes	NIPDAU	Level-1-260C-UNLIM	-40 to 85	TL2844
TL2844DR-8.A	Active	Production	SOIC (D) 8	2500 LARGE T&R	Yes	NIPDAU	Level-1-260C-UNLIM	-40 to 85	TL2844
TL2844DR.A	Active	Production	SOIC (D) 14	2500 LARGE T&R	Yes	NIPDAU	Level-1-260C-UNLIM	-40 to 85	TL2844
TL2844DRG4	Active	Production	SOIC (D) 14	2500 LARGE T&R	Yes	NIPDAU	Level-1-260C-UNLIM	-40 to 85	TL2844
TL2844P	NRND	Production	PDIP (P) 8	50 TUBE	Yes	NIPDAU	N/A for Pkg Type	-40 to 85	TL2844P
TL2844P.A	NRND	Production	PDIP (P) 8	50 TUBE	Yes	NIPDAU	N/A for Pkg Type	-40 to 85	TL2844P
TL2844PE4	NRND	Production	PDIP (P) 8	50 TUBE	Yes	NIPDAU	N/A for Pkg Type	-40 to 85	TL2844P
TL2845D	Obsolete	Production	SOIC (D) 14	-	-	Call TI	Call TI	-40 to 85	TL2845
TL2845D-8	Obsolete	Production	SOIC (D) 8	-	-	Call TI	Call TI	-40 to 85	TL2845

Orderable part number	Status (1)	Material type (2)	Package Pins	Package qty Carrier	RoHS (3)	Lead finish/ Ball material (4)	MSL rating/ Peak reflow (5)	Op temp (°C)	Part marking (6)
TL2845DR	Active	Production	SOIC (D) 14	2500 LARGE T&R	Yes	NIPDAU	Level-1-260C-UNLIM	-40 to 85	TL2845
TL2845DR-8	Active	Production	SOIC (D) 8	2500 LARGE T&R	Yes	NIPDAU	Level-1-260C-UNLIM	-40 to 85	TL2845
TL2845DR-8.A	Active	Production	SOIC (D) 8	2500 LARGE T&R	Yes	NIPDAU	Level-1-260C-UNLIM	-40 to 85	TL2845
TL2845DR.A	Active	Production	SOIC (D) 14	2500 LARGE T&R	Yes	NIPDAU	Level-1-260C-UNLIM	-40 to 85	TL2845
TL2845DRG4	Active	Production	SOIC (D) 14	2500 LARGE T&R	Yes	NIPDAU	Level-1-260C-UNLIM	-40 to 85	TL2845
TL2845P	NRND	Production	PDIP (P) 8	50 TUBE	Yes	NIPDAU	N/A for Pkg Type	-40 to 85	TL2845P
TL2845P.A	NRND	Production	PDIP (P) 8	50 TUBE	Yes	NIPDAU	N/A for Pkg Type	-40 to 85	TL2845P
TL3842D-8	Obsolete	Production	SOIC (D) 8	-	-	Call TI	Call TI	0 to 70	TL3842
TL3842DR	Active	Production	SOIC (D) 14	2500 LARGE T&R	Yes	NIPDAU	Level-2-260C-1 YEAR	0 to 70	TL3842
TL3842DR-8	Active	Production	SOIC (D) 8	2500 LARGE T&R	Yes	NIPDAU	Level-2-260C-1 YEAR	0 to 70	TL3842
TL3842DR-8.A	Active	Production	SOIC (D) 8	2500 LARGE T&R	Yes	NIPDAU	Level-2-260C-1 YEAR	0 to 70	TL3842
TL3842DR.A	Active	Production	SOIC (D) 14	2500 LARGE T&R	Yes	NIPDAU	Level-2-260C-1 YEAR	0 to 70	TL3842
TL3842DRE4-8	Active	Production	SOIC (D) 8	2500 LARGE T&R	Yes	NIPDAU	Level-2-260C-1 YEAR	0 to 70	TL3842
TL3842P	Active	Production	PDIP (P) 8	50 TUBE	Yes	NIPDAU	N/A for Pkg Type	0 to 70	TL3842P
TL3842P.A	Active	Production	PDIP (P) 8	50 TUBE	Yes	NIPDAU	N/A for Pkg Type	0 to 70	TL3842P
TL3842PE4	Active	Production	PDIP (P) 8	50 TUBE	Yes	NIPDAU	N/A for Pkg Type	0 to 70	TL3842P
TL3843D	Obsolete	Production	SOIC (D) 14	-	-	Call TI	Call TI	0 to 70	TL3843
TL3843D-8	Obsolete	Production	SOIC (D) 8	-	-	Call TI	Call TI	0 to 70	TL3843
TL3843DR	Active	Production	SOIC (D) 14	2500 LARGE T&R	Yes	NIPDAU	Level-1-260C-UNLIM	0 to 70	TL3843
TL3843DR-8	Active	Production	SOIC (D) 8	2500 LARGE T&R	Yes	NIPDAU	Level-1-260C-UNLIM	0 to 70	TL3843
TL3843DR-8.A	Active	Production	SOIC (D) 8	2500 LARGE T&R	Yes	NIPDAU	Level-1-260C-UNLIM	0 to 70	TL3843
TL3843DR.A	Active	Production	SOIC (D) 14	2500 LARGE T&R	Yes	NIPDAU	Level-1-260C-UNLIM	0 to 70	TL3843
TL3843P	Active	Production	PDIP (P) 8	50 TUBE	Yes	NIPDAU	N/A for Pkg Type	0 to 70	TL3843P
TL3843P.A	Active	Production	PDIP (P) 8	50 TUBE	Yes	NIPDAU	N/A for Pkg Type	0 to 70	TL3843P
TL3844D	Obsolete	Production	SOIC (D) 14	-	-	Call TI	Call TI	0 to 70	TL3844
TL3844D-8	Obsolete	Production	SOIC (D) 8	-	-	Call TI	Call TI	0 to 70	TL3844
TL3844DR	Active	Production	SOIC (D) 14	2500 LARGE T&R	Yes	NIPDAU	Level-1-260C-UNLIM	0 to 70	TL3844
TL3844DR-8	Active	Production	SOIC (D) 8	2500 LARGE T&R	Yes	NIPDAU	Level-1-260C-UNLIM	0 to 70	TL3844
TL3844DR-8.A	Active	Production	SOIC (D) 8	2500 LARGE T&R	Yes	NIPDAU	Level-1-260C-UNLIM	0 to 70	TL3844
TL3844DR.A	Active	Production	SOIC (D) 14	2500 LARGE T&R	Yes	NIPDAU	Level-1-260C-UNLIM	0 to 70	TL3844
TL3844P	Active	Production	PDIP (P) 8	50 TUBE	Yes	NIPDAU	N/A for Pkg Type	0 to 70	TL3844P

Orderable part number	Status (1)	Material type (2)	Package Pins	Package qty Carrier	RoHS (3)	Lead finish/ Ball material (4)	MSL rating/ Peak reflow (5)	Op temp (°C)	Part marking (6)
TL3844P.A	Active	Production	PDIP (P) 8	50 TUBE	Yes	NIPDAU	N/A for Pkg Type	0 to 70	TL3844P
TL3844PE4	Active	Production	PDIP (P) 8	50 TUBE	Yes	NIPDAU	N/A for Pkg Type	0 to 70	TL3844P
TL3845D	Active	Production	SOIC (D) 14	50 TUBE	Yes	NIPDAU	Level-1-260C-UNLIM	0 to 70	TL3845
TL3845D-8	Obsolete	Production	SOIC (D) 8	-	-	Call TI	Call TI	0 to 70	TL3845
TL3845D.A	Active	Production	SOIC (D) 14	50 TUBE	Yes	NIPDAU	Level-1-260C-UNLIM	0 to 70	TL3845
TL3845DR	Active	Production	SOIC (D) 14	2500 LARGE T&R	Yes	NIPDAU	Level-1-260C-UNLIM	0 to 70	TL3845
TL3845DR-8	Active	Production	SOIC (D) 8	2500 LARGE T&R	Yes	NIPDAU	Level-1-260C-UNLIM	0 to 70	TL3845
TL3845DR-8.A	Active	Production	SOIC (D) 8	2500 LARGE T&R	Yes	NIPDAU	Level-1-260C-UNLIM	0 to 70	TL3845
TL3845DR.A	Active	Production	SOIC (D) 14	2500 LARGE T&R	Yes	NIPDAU	Level-1-260C-UNLIM	0 to 70	TL3845
TL3845P	Active	Production	PDIP (P) 8	50 TUBE	Yes	NIPDAU	N/A for Pkg Type	0 to 70	TL3845P
TL3845P.A	Active	Production	PDIP (P) 8	50 TUBE	Yes	NIPDAU	N/A for Pkg Type	0 to 70	TL3845P
TL3845PE4	Active	Production	PDIP (P) 8	50 TUBE	Yes	NIPDAU	N/A for Pkg Type	0 to 70	TL3845P

(1) **Status:** For more details on status, see our [product life cycle](#).

(2) **Material type:** When designated, preproduction parts are prototypes/experimental devices, and are not yet approved or released for full production. Testing and final process, including without limitation quality assurance, reliability performance testing, and/or process qualification, may not yet be complete, and this item is subject to further changes or possible discontinuation. If available for ordering, purchases will be subject to an additional waiver at checkout, and are intended for early internal evaluation purposes only. These items are sold without warranties of any kind.

(3) **RoHS values:** Yes, No, RoHS Exempt. See the [TI RoHS Statement](#) for additional information and value definition.

(4) **Lead finish/Ball material:** Parts may have multiple material finish options. Finish options are separated by a vertical ruled line. Lead finish/Ball material values may wrap to two lines if the finish value exceeds the maximum column width.

(5) **MSL rating/Peak reflow:** The moisture sensitivity level ratings and peak solder (reflow) temperatures. In the event that a part has multiple moisture sensitivity ratings, only the lowest level per JEDEC standards is shown. Refer to the shipping label for the actual reflow temperature that will be used to mount the part to the printed circuit board.

(6) **Part marking:** There may be an additional marking, which relates to the logo, the lot trace code information, or the environmental category of the part.

Multiple part markings will be inside parentheses. Only one part marking contained in parentheses and separated by a "~" will appear on a part. If a line is indented then it is a continuation of the previous line and the two combined represent the entire part marking for that device.

Important Information and Disclaimer: The information provided on this page represents TI's knowledge and belief as of the date that it is provided. TI bases its knowledge and belief on information provided by third parties, and makes no representation or warranty as to the accuracy of such information. Efforts are underway to better integrate information from third parties. TI has taken and continues to take reasonable steps to provide representative and accurate information but may not have conducted destructive testing or chemical analysis on incoming materials and chemicals. TI and TI suppliers consider certain information to be proprietary, and thus CAS numbers and other limited information may not be available for release.

In no event shall TI's liability arising out of such information exceed the total purchase price of the TI part(s) at issue in this document sold by TI to Customer on an annual basis.

TAPE AND REEL INFORMATION

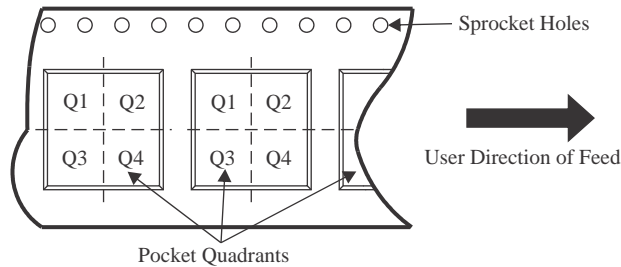
QUADRANT ASSIGNMENTS FOR PIN 1 ORIENTATION IN TAPE

*All dimensions are nominal

Device	Package Type	Package Drawing	Pins	SPQ	Reel Diameter (mm)	Reel Width W1 (mm)	A0 (mm)	B0 (mm)	K0 (mm)	P1 (mm)	W (mm)	Pin1 Quadrant
TL2842DR	SOIC	D	14	2500	330.0	16.4	6.5	9.0	2.1	8.0	16.0	Q1
TL2842DR-8	SOIC	D	8	2500	330.0	12.4	6.4	5.2	2.1	8.0	12.0	Q1
TL2843DR	SOIC	D	14	2500	330.0	16.4	6.5	9.0	2.1	8.0	16.0	Q1
TL2843DR-8	SOIC	D	8	2500	330.0	12.4	6.4	5.2	2.1	8.0	12.0	Q1
TL2844DR	SOIC	D	14	2500	330.0	16.4	6.5	9.0	2.1	8.0	16.0	Q1
TL2844DR-8	SOIC	D	8	2500	330.0	12.4	6.4	5.2	2.1	8.0	12.0	Q1
TL2845DR	SOIC	D	14	2500	330.0	16.4	6.5	9.0	2.1	8.0	16.0	Q1
TL2845DR-8	SOIC	D	8	2500	330.0	12.4	6.4	5.2	2.1	8.0	12.0	Q1
TL3842DR	SOIC	D	14	2500	330.0	16.4	6.5	9.0	2.1	8.0	16.0	Q1
TL3842DR-8	SOIC	D	8	2500	330.0	12.4	6.4	5.2	2.1	8.0	12.0	Q1
TL3843DR	SOIC	D	14	2500	330.0	16.4	6.5	9.0	2.1	8.0	16.0	Q1
TL3843DR-8	SOIC	D	8	2500	330.0	12.4	6.4	5.2	2.1	8.0	12.0	Q1
TL3844DR	SOIC	D	14	2500	330.0	16.4	6.5	9.0	2.1	8.0	16.0	Q1
TL3844DR-8	SOIC	D	8	2500	330.0	12.4	6.4	5.2	2.1	8.0	12.0	Q1
TL3845DR	SOIC	D	14	2500	330.0	16.4	6.5	9.0	2.1	8.0	16.0	Q1
TL3845DR-8	SOIC	D	8	2500	330.0	12.4	6.4	5.2	2.1	8.0	12.0	Q1

TAPE AND REEL BOX DIMENSIONS

*All dimensions are nominal

Device	Package Type	Package Drawing	Pins	SPQ	Length (mm)	Width (mm)	Height (mm)
TL2842DR	SOIC	D	14	2500	353.0	353.0	32.0
TL2842DR-8	SOIC	D	8	2500	353.0	353.0	32.0
TL2843DR	SOIC	D	14	2500	353.0	353.0	32.0
TL2843DR-8	SOIC	D	8	2500	353.0	353.0	32.0
TL2844DR	SOIC	D	14	2500	353.0	353.0	32.0
TL2844DR-8	SOIC	D	8	2500	353.0	353.0	32.0
TL2845DR	SOIC	D	14	2500	353.0	353.0	32.0
TL2845DR-8	SOIC	D	8	2500	353.0	353.0	32.0
TL3842DR	SOIC	D	14	2500	353.0	353.0	32.0
TL3842DR-8	SOIC	D	8	2500	353.0	353.0	32.0
TL3843DR	SOIC	D	14	2500	353.0	353.0	32.0
TL3843DR-8	SOIC	D	8	2500	353.0	353.0	32.0
TL3844DR	SOIC	D	14	2500	353.0	353.0	32.0
TL3844DR-8	SOIC	D	8	2500	353.0	353.0	32.0
TL3845DR	SOIC	D	14	2500	353.0	353.0	32.0
TL3845DR-8	SOIC	D	8	2500	353.0	353.0	32.0

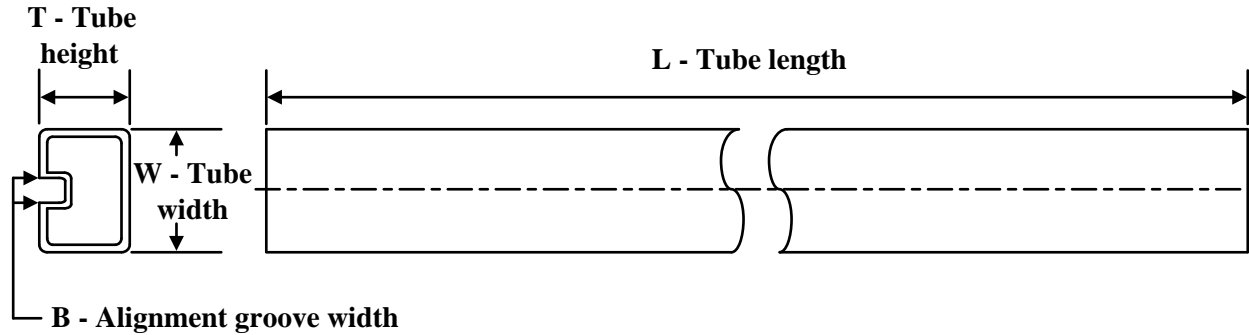
TUBE

*All dimensions are nominal

Device	Package Name	Package Type	Pins	SPQ	L (mm)	W (mm)	T (µm)	B (mm)
TL2842P	P	PDIP	8	50	506	13.97	11230	4.32
TL2842P.A	P	PDIP	8	50	506	13.97	11230	4.32
TL2843P	P	PDIP	8	50	506	13.97	11230	4.32
TL2843P.A	P	PDIP	8	50	506	13.97	11230	4.32
TL2844P	P	PDIP	8	50	506	13.97	11230	4.32
TL2844P.A	P	PDIP	8	50	506	13.97	11230	4.32
TL2844PE4	P	PDIP	8	50	506	13.97	11230	4.32
TL2845P	P	PDIP	8	50	506	13.97	11230	4.32
TL2845P.A	P	PDIP	8	50	506	13.97	11230	4.32
TL3842P	P	PDIP	8	50	506	13.97	11230	4.32
TL3842P.A	P	PDIP	8	50	506	13.97	11230	4.32
TL3842PE4	P	PDIP	8	50	506	13.97	11230	4.32
TL3843P	P	PDIP	8	50	506	13.97	11230	4.32
TL3843P.A	P	PDIP	8	50	506	13.97	11230	4.32
TL3844P	P	PDIP	8	50	506	13.97	11230	4.32
TL3844P.A	P	PDIP	8	50	506	13.97	11230	4.32
TL3844PE4	P	PDIP	8	50	506	13.97	11230	4.32
TL3845D	D	SOIC	14	50	506.6	8	3940	4.32
TL3845D.A	D	SOIC	14	50	506.6	8	3940	4.32
TL3845P	P	PDIP	8	50	506	13.97	11230	4.32
TL3845P.A	P	PDIP	8	50	506	13.97	11230	4.32
TL3845PE4	P	PDIP	8	50	506	13.97	11230	4.32

D0014A



PACKAGE OUTLINE

SOIC - 1.75 mm max height

SMALL OUTLINE INTEGRATED CIRCUIT



4220718/A 09/2016

NOTES:

1. All linear dimensions are in millimeters. Dimensions in parenthesis are for reference only. Dimensioning and tolerancing per ASME Y14.5M.
2. This drawing is subject to change without notice.
3. This dimension does not include mold flash, protrusions, or gate burrs. Mold flash, protrusions, or gate burrs shall not exceed 0.15 mm, per side.
4. This dimension does not include interlead flash. Interlead flash shall not exceed 0.43 mm, per side.
5. Reference JEDEC registration MS-012, variation AB.

EXAMPLE BOARD LAYOUT

D0014A

SOIC - 1.75 mm max height

SMALL OUTLINE INTEGRATED CIRCUIT



LAND PATTERN EXAMPLE
SCALE:8X



SOLDER MASK DETAILS

4220718/A 09/2016

NOTES: (continued)

- 6. Publication IPC-7351 may have alternate designs.
- 7. Solder mask tolerances between and around signal pads can vary based on board fabrication site.

EXAMPLE STENCIL DESIGN

D0014A

SOIC - 1.75 mm max height

SMALL OUTLINE INTEGRATED CIRCUIT



SOLDER PASTE EXAMPLE
BASED ON 0.125 mm THICK STENCIL
SCALE:8X

4220718/A 09/2016

NOTES: (continued)

8. Laser cutting apertures with trapezoidal walls and rounded corners may offer better paste release. IPC-7525 may have alternate design recommendations.
9. Board assembly site may have different recommendations for stencil design.



D0008A

PACKAGE OUTLINE

SOIC - 1.75 mm max height

SMALL OUTLINE INTEGRATED CIRCUIT



4214825/C 02/2019

NOTES:

- Linear dimensions are in inches [millimeters]. Dimensions in parenthesis are for reference only. Controlling dimensions are in inches. Dimensioning and tolerancing per ASME Y14.5M.
- This drawing is subject to change without notice.
- This dimension does not include mold flash, protrusions, or gate burrs. Mold flash, protrusions, or gate burrs shall not exceed $.006$ [0.15] per side.
- This dimension does not include interlead flash.
- Reference JEDEC registration MS-012, variation AA.

EXAMPLE BOARD LAYOUT

D0008A

SOIC - 1.75 mm max height

SMALL OUTLINE INTEGRATED CIRCUIT



LAND PATTERN EXAMPLE
EXPOSED METAL SHOWN
SCALE:8X



SOLDER MASK DETAILS

4214825/C 02/2019

NOTES: (continued)

- 6. Publication IPC-7351 may have alternate designs.
- 7. Solder mask tolerances between and around signal pads can vary based on board fabrication site.

EXAMPLE STENCIL DESIGN

D0008A

SOIC - 1.75 mm max height

SMALL OUTLINE INTEGRATED CIRCUIT



SOLDER PASTE EXAMPLE
BASED ON .005 INCH [0.125 MM] THICK STENCIL
SCALE:8X

4214825/C 02/2019

NOTES: (continued)

8. Laser cutting apertures with trapezoidal walls and rounded corners may offer better paste release. IPC-7525 may have alternate design recommendations.
9. Board assembly site may have different recommendations for stencil design.

P (R-PDIP-T8)

PLASTIC DUAL-IN-LINE PACKAGE

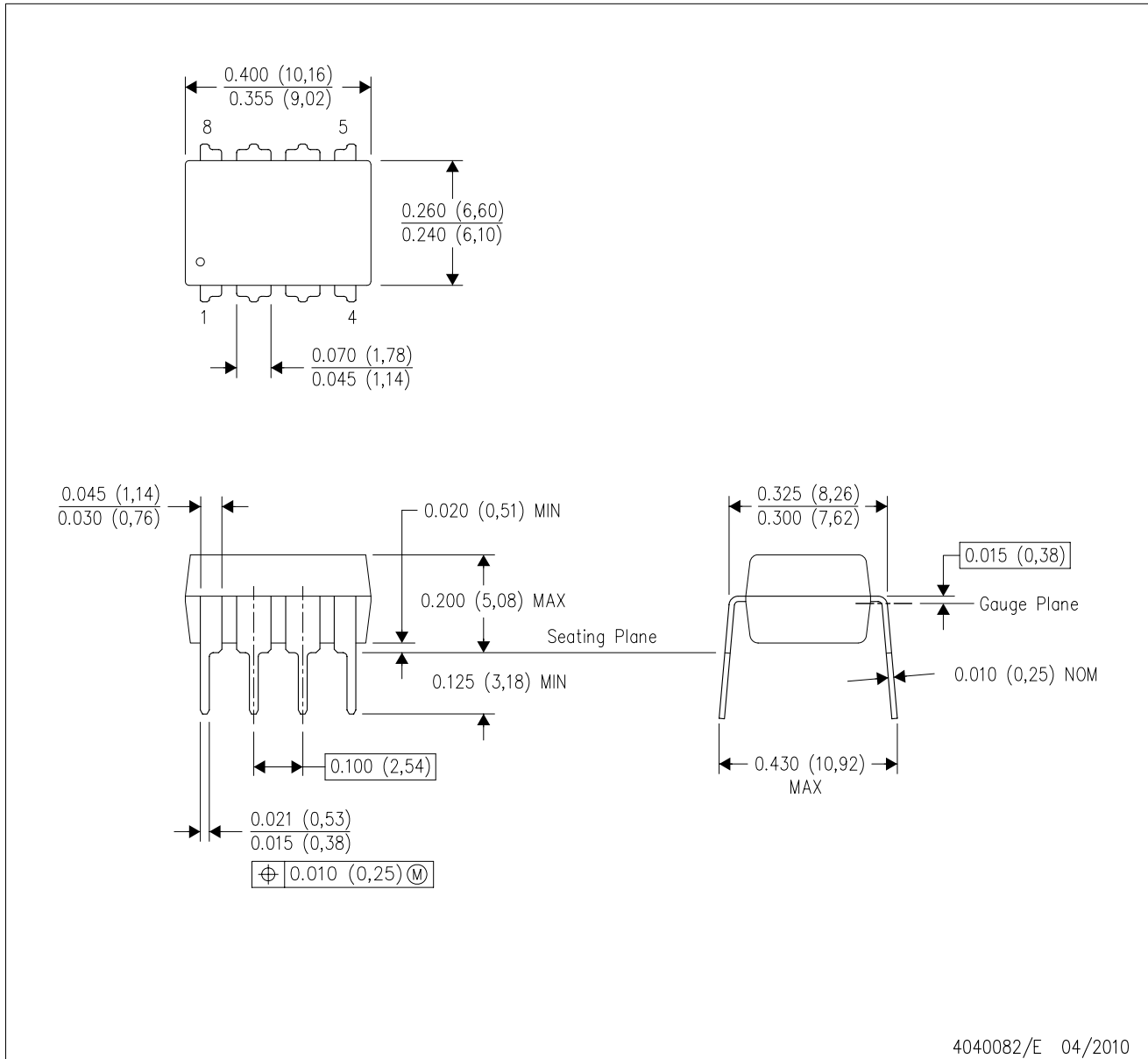

4040082/E 04/2010

- NOTES:
- A. All linear dimensions are in inches (millimeters).
 - B. This drawing is subject to change without notice.
 - C. Falls within JEDEC MS-001 variation BA.

重要なお知らせと免責事項

TI は、技術データと信頼性データ (データシートを含みます)、設計リソース (リファレンス デザインを含みます)、アプリケーションや設計に関する各種アドバイス、Web ツール、安全性情報、その他のリソースを、欠陥が存在する可能性のある「現状のまま」提供しており、商品性および特定目的に対する適合性の黙示保証、第三者の知的財産権の非侵害保証を含むいかなる保証も、明示的または黙示的にかかわらず拒否します。

これらのリソースは、TI 製品を使用する設計の経験を積んだ開発者への提供を意図したものです。(1) お客様のアプリケーションに適した TI 製品の選定、(2) お客様のアプリケーションの設計、検証、試験、(3) お客様のアプリケーションに該当する各種規格や、その他のあらゆる安全性、セキュリティ、規制、または他の要件への確実な適合に関する責任を、お客様のみが単独で負うものとし、

上記の各種リソースは、予告なく変更される可能性があります。これらのリソースは、リソースで説明されている TI 製品を使用するアプリケーションの開発の目的でのみ、TI はその使用をお客様に許諾します。これらのリソースに関して、他の目的で複製することや掲載することは禁止されています。TI や第三者の知的財産権のライセンスが付与されている訳ではありません。お客様は、これらのリソースを自身で使用した結果発生するあらゆる申し立て、損害、費用、損失、責任について、TI およびその代理人を完全に補償するものとし、TI は一切の責任を拒否します。

TI の製品は、[TI の販売条件](#)、[TI の総合的な品質ガイドライン](#)、[ti.com](#) または TI 製品などに関連して提供される他の適用条件に従い提供されます。TI がこれらのリソースを提供することは、適用される TI の保証または他の保証の放棄の拡大や変更を意味するものではありません。TI がカスタム、またはカスタマー仕様として明示的に指定していない限り、TI の製品は標準的なカタログに掲載される汎用機器です。

お客様がいかなる追加条項または代替条項を提案する場合も、TI はそれらに異議を唱え、拒否します。

Copyright © 2026, Texas Instruments Incorporated

最終更新日 : 2025 年 10 月