

TL431LI-Q1 / TL432LI-Q1 リファレンス電流が最適化された、プログラム可能なシャント・レギュレータ

1 特長

- 車載アプリケーション用に認定済み
- 下記内容で AEC-Q100 認定済み
 - デバイス温度グレード 1: 動作時周囲温度 $-40^{\circ}\text{C} \sim +125^{\circ}\text{C}$
 - デバイス温度グレード 0: 動作時周囲温度 $-40^{\circ}\text{C} \sim +150^{\circ}\text{C}$
- 25°C での基準電圧の許容公差
 - 0.5% (B グレード)
 - 1% (A グレード)
- 出力電圧の最小値: 2.495V (標準値)
- 可変出力電圧: $V_{\text{ref}} \sim 36\text{V}$
- グレード 1 の最大温度ドリフト 27mV
- グレード 0 の最大温度ドリフト 34mV
- 出力インピーダンス: 0.3Ω (標準値)
- シンク電流能力
 - $I_{\text{min}} = 0.6\text{mA}$ (最大値)
 - $I_{\text{KA}} = 15\text{mA}$ (最大値)
- 基準入力電流 $I_{\text{REF}} = 0.4\mu\text{A}$ (最大値)
- 全温度範囲にわたる基準入力電流の偏差、 $I_{(\text{dev})} = 0.3\mu\text{A}$ (最大値)

2 アプリケーション

- インバータおよびモータ制御
- DC/DC コンバータ
- LED ライティング
- オンボード充電器 (OBC)
- インフォテインメント / クラスタ
- エンジン管理アクチュエータ
- トランスミッション
- パワー・ステアリング
- パワートレイン排気ガス・センサ
- オルタネータ・スタータ

3 概要

TL431LI-Q1 は 3 端子の可変シャント・レギュレータであり、該当する車載、民生、軍用温度範囲全体にわたって熱的な安定性が規定されています。出力電圧は、2 つの外付け抵抗を使用して、 V_{ref} (約 2.495V) と 36V の間の任意の値に設定できます。このデバイスの出力インピーダンスは 0.3Ω (標準値) です。このデバイスは、アクティブ出力回路による非常に鋭い起動特性を備えているため、オンボード・レギュレーション、可変電源、スイッチング電源などの多くの用途でツェナー・ダイオードの優れた代替品となります。このデバイスは業界標準の TL431-Q1 のピン互換代替品であり、 I_{ref} と I_{dev} の性能が最適化されています。TL431LI-Q1 は I_{ref} と I_{dev} の値が小さいため、設計者はシステム精度の向上とリーク電流の低減を達成できます。TL432LI-Q1 の機能と電氣的仕様は TL431LI-Q1 と完全に同じですが、DBZ パッケージのピン配置が異なります。

TL431LI-Q1 は、初期公差 (25°C 時) が 0.5% の B グレードと、1% の A グレードの 2 つのグレードで供給されます。また TL431LI-Q1 は、グレード 1 (型番では「Q」で表されます) とグレード 0 (型番では「E」で表されます) の 2 つの温度グレードで供給され、これらの温度グレードは、動作時の最高周囲温度がそれぞれ 125°C と 150°C であることを表しています。TL43xLI-Q1 のグレード 1 は $-40^{\circ}\text{C} \sim 125^{\circ}\text{C}$ 、グレード 0 は $-40^{\circ}\text{C} \sim 150^{\circ}\text{C}$ で動作が規定されており、温度に対する出力ドリフトが小さいため温度範囲全体にわたって優れた安定性が得られます。

製品情報⁽¹⁾

型番	パッケージ(ピン)	本体サイズ(公称)
TL43xLI-Q1	SOT-23 (3)	2.90mmx1.30mm

(1) 提供されているすべてのパッケージについては、巻末の注文情報を参照してください。

概略回路図

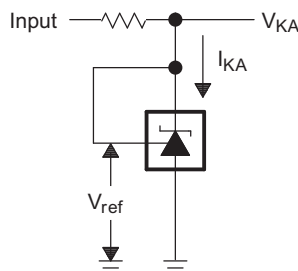

目次

1	特長	1	9.3	Feature Description	12
2	アプリケーション	1	9.4	Device Functional Modes	12
3	概要	1	10	Applications and Implementation	13
4	改訂履歴	2	10.1	Application Information	13
5	Device Comparison Table	3	10.2	Typical Applications	13
6	Pin Configuration and Functions	3	10.3	System Examples	22
7	Specifications	4	11	Power Supply Recommendations	25
7.1	Absolute Maximum Ratings	4	12	Layout	25
7.2	ESD Ratings	4	12.1	Layout Guidelines	25
7.3	Recommended Operating Conditions	4	12.2	Layout Example	25
7.4	Thermal Information	4	13	デバイスおよびドキュメントのサポート	26
7.5	Electrical Characteristics	5	13.1	デバイス・サポート	26
7.6	Typical Characteristics	6	13.2	ドキュメントのサポート	26
8	Parameter Measurement Information	9	13.3	関連リンク	26
8.1	Temperature Coefficient	9	13.4	ドキュメントの更新通知を受け取る方法	26
8.2	Dynamic Impedance	10	13.5	サポート・リソース	26
9	Detailed Description	11	13.6	商標	27
9.1	Overview	11	13.7	静電気放電に関する注意事項	27
9.2	Functional Block Diagram	11	13.8	Glossary	27
			14	メカニカル、パッケージ、および注文情報	27

4 改訂履歴

資料番号末尾の英字は改訂を表しています。その改訂履歴は英語版に準じています。

2019年5月発行のものから更新

Page

•	デバイスのステータスを「事前情報」から「量産データ」に変更	1
---	-------------------------------	---

5 Device Comparison Table

DEVICE PINOUT	INITIAL ACCURACY	OPERATING FREE-AIR TEMPERATURE (T _A)
TL431LI-Q1 TL432LI-Q1	A: 1% B: 0.5%	Q: -40°C to 125°C E: -40°C to 150°C

6 Pin Configuration and Functions

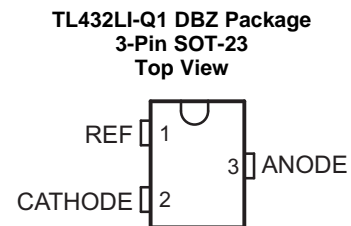
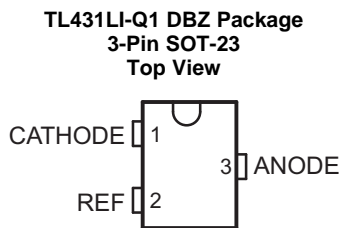

Pin Functions

NAME	PIN NUMBER		TYPE	DESCRIPTION
	TL431LI-Q1	TL432LI-Q1		
	DBZ	DBZ		
ANODE	3	3	O	Common pin, normally connected to ground
CATHODE	1	2	I/O	Shunt current/Voltage input
REF	2	1	I	Threshold relative to common anode

7 Specifications

7.1 Absolute Maximum Ratings

over operating free-air temperature range (unless otherwise noted)⁽¹⁾

		MIN	MAX	UNIT
V _{KA}	Cathode Voltage ⁽²⁾		37	V
I _{KA}	Continuous Cathode Current Range	-10	18	mA
I _{I(ref)}	Reference Input Current	-5	10	mA
T _J	Operating Junction Temperature Range	-40	150	C
T _{stg}	Storage Temperature Range	-65	150	C

- (1) Stresses beyond those listed under *Absolute Maximum Ratings* may cause permanent damage to the device. These are stress ratings only, which do not imply functional operation of the device at these or any other conditions beyond those indicated under *Recommended Operating Conditions*. Exposure to absolute-maximum-rated conditions for extended periods may affect device reliability.
- (2) All voltage values are with respect to ANODE, unless otherwise noted.

7.2 ESD Ratings

		VALUE	UNIT
V _(ESD)	Electrostatic discharge	Human body model (HBM), per AEC Q100-002 ⁽¹⁾	±4000
		Charged-device model (CDM), per AEC Q100-011	±1000

- (1) AEC Q100-002 indicates that HBM stressing shall be in accordance with the ANSI/ESDA/JEDEC JS-001 specification

7.3 Recommended Operating Conditions

		MIN	MAX	UNIT	
V _{KA}	Cathode Voltage	V _{REF}	36	V	
I _{KA}	Continuous Cathode Current Range	0.6	15	mA	
T _A	Operating Free-Air Temperature ⁽¹⁾	TL43xLIxQ	-40	125	C
		TL43xLIxE	-40	150	C

- (1) Maximum power dissipation is a function of T_{J(max)}, θ_{JA}, and T_A. The maximum allowable power dissipation at any allowable ambient temperature is P_D = (T_{J(max)} - T_A)/θ_{JA}. Operating at the absolute maximum T_J can affect reliability. Please see the [Semiconductor and IC Package Thermal Metrics Application Report](#) for more information.

7.4 Thermal Information

THERMAL METRIC ⁽¹⁾		TL43xLI	UNIT
		DBZ	
		3 PINS	
R _{θJA}	Junction-to-ambient thermal resistance	371.7	C/W
R _{θJC(top)}	Junction-to-case (top) thermal resistance	145.9	C/W
R _{θJB}	Junction-to-board thermal resistance	104.7	C/W
ψ _{JT}	Junction-to-top characterization resistance	23.9	C/W
ψ _{JB}	Junction-to-board characterization resistance	102.9	C/W

- (1) For more information about traditional and new thermal metrics, see the [Semiconductor and IC Package Thermal Metrics Application Report](#).

7.5 Electrical Characteristics

over recommended operating conditions, $T_A = 25^\circ\text{C}$ (unless otherwise noted)

PARAMETER	TEST CIRCUIT	TEST CONDITIONS	MIN	TYP	MAX	UNIT			
V_{ref}	Reference Voltage	See 14	$V_{\text{KA}} = V_{\text{ref}}, I_{\text{KA}} = 1 \text{ mA}$	TL43xLlAx devices	2470	2495	2520	mV	
				TL43xLlBx devices	2483	2495	2507	mV	
$V_{\text{I(dev)}}$	Deviation of reference input voltage over full temperature range ⁽¹⁾	See 14	$V_{\text{KA}} = V_{\text{ref}}, I_{\text{KA}} = 1 \text{ mA}$	TL43xLlQ devices		10	27	mV	
				TL43xLlEx devices		14	34	mV	
$\frac{\Delta V_{\text{ref}}}{\Delta V_{\text{KA}}}$	Ratio of change in reference voltage to the change in cathode voltage	See 15	$I_{\text{KA}} = 1 \text{ mA}$	$\Delta V_{\text{KA}} = 10 \text{ V} - V_{\text{ref}}$		-1.4	-2.7	mV/V	
				$\Delta V_{\text{KA}} = 36 \text{ V} - 10 \text{ V}$		-1	-2	mV/V	
I_{ref}	Reference Input Current	See 15	$I_{\text{KA}} = 1 \text{ mA}, R1 = 10\text{k}\Omega, R2 = \infty$				0.2	0.4	μA
$I_{\text{I(dev)}}$	Deviation of reference input current over full temperature range ⁽¹⁾	See 15	$I_{\text{KA}} = 1 \text{ mA}, R1 = 10\text{k}\Omega, R2 = \infty$				0.1	0.3	μA
I_{min}	Minimum cathode current for regulation	See 14	$V_{\text{KA}} = V_{\text{ref}}$					0.6	mA
I_{off}	Off-state cathode current	See 16	$V_{\text{KA}} = 36 \text{ V}, V_{\text{ref}} = 0$				0.1	1	μA
$ Z_{\text{KA}} $	Dynamic Impedance ⁽²⁾	See 14	$V_{\text{KA}} = V_{\text{ref}}, I_{\text{KA}} = 1 \text{ mA to } 15 \text{ mA}$				0.3	0.75	Ω

- (1) The deviation parameters $V_{\text{I(dev)}}$ and $I_{\text{I(dev)}}$ are defined as the differences between the maximum and minimum values obtained over the rated temperature range. For more details on $V_{\text{I(dev)}}$ and how it relates to the average temperature coefficient, see the [Temperature Coefficient](#) section.
- (2) The dynamic impedance is defined by $|Z_{\text{KA}}| = \Delta V_{\text{KA}} / \Delta I_{\text{KA}}$. For more details on $|Z_{\text{KA}}|$ and how it relates to V_{KA} , see the [Temperature Coefficient](#) section.

7.6 Typical Characteristics

Data at high and low temperatures are applicable only within the recommended operating free-air temperature ranges of the various devices.

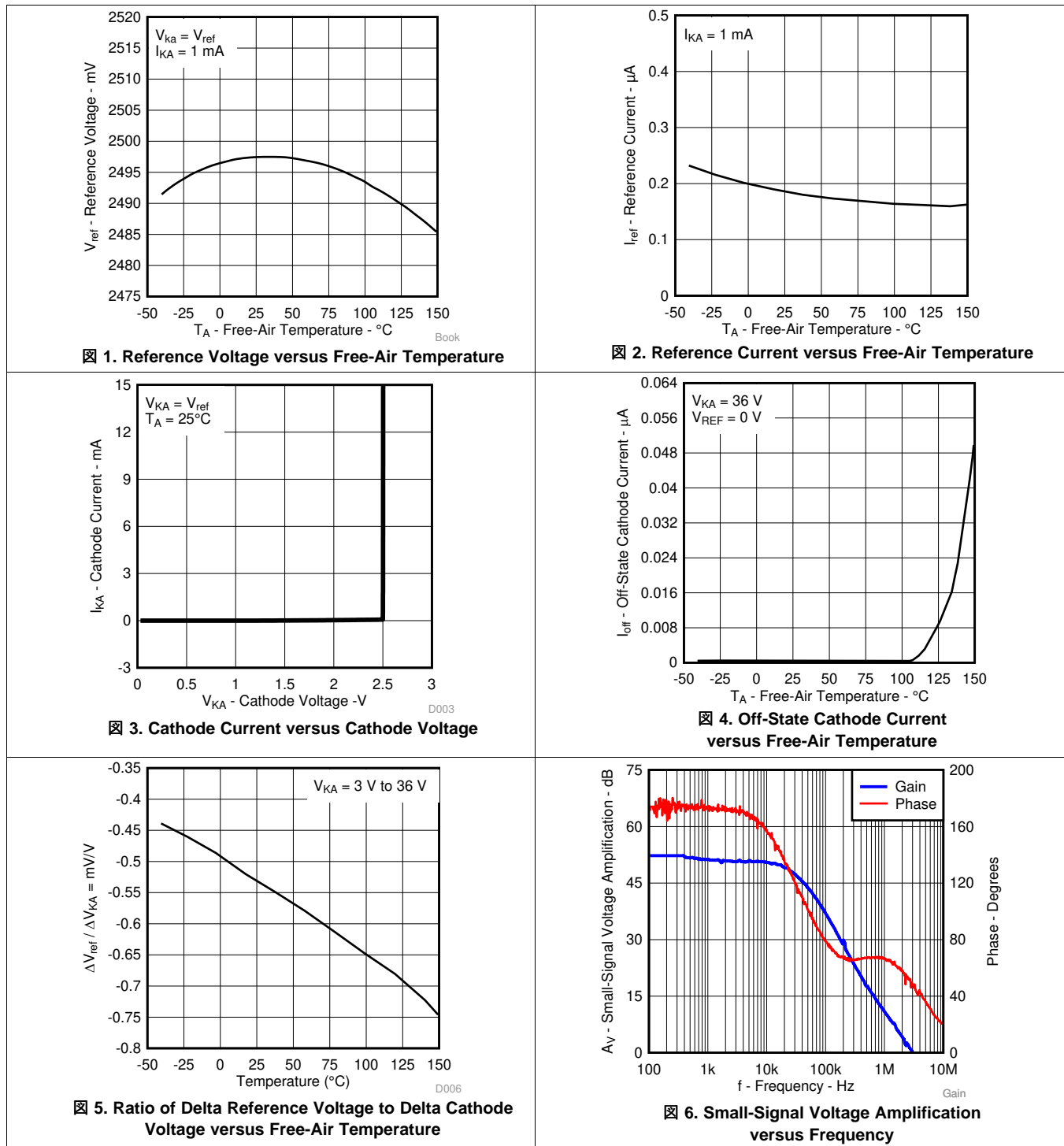

Typical Characteristics (continued)

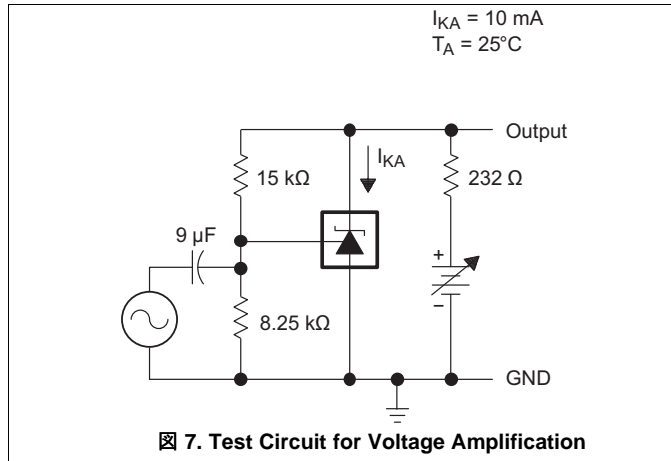

Fig. 7. Test Circuit for Voltage Amplification

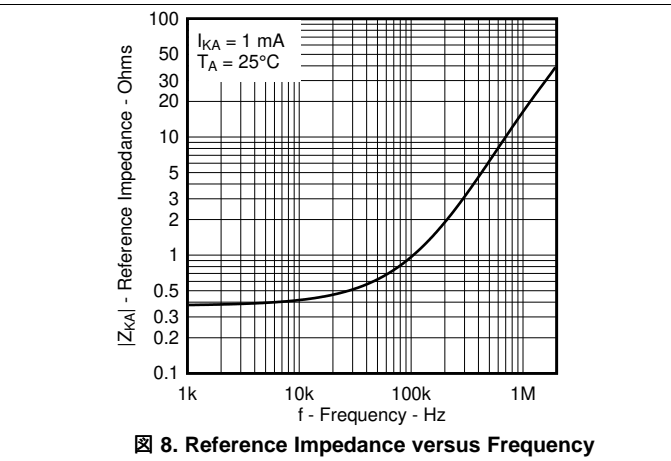

Fig. 8. Reference Impedance versus Frequency

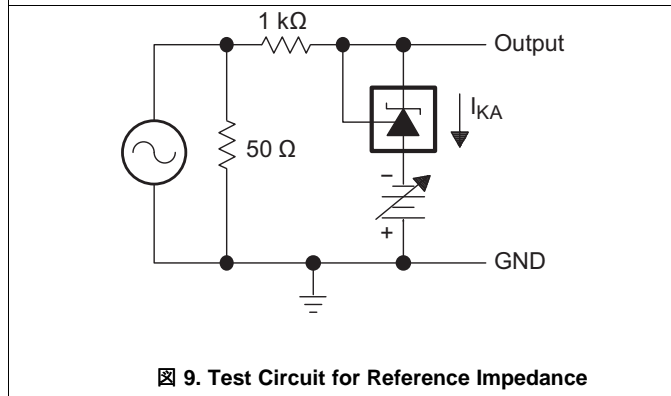

Fig. 9. Test Circuit for Reference Impedance

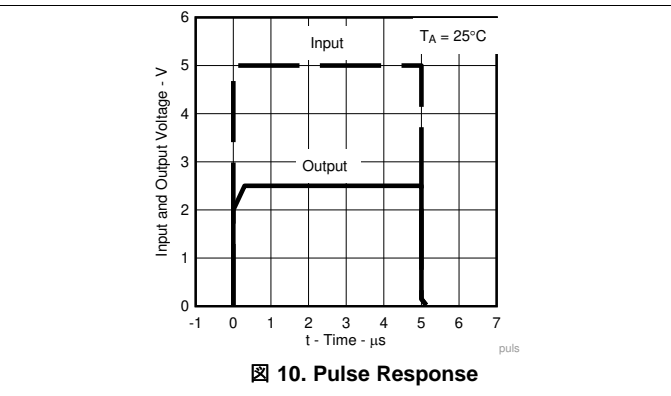

Fig. 10. Pulse Response

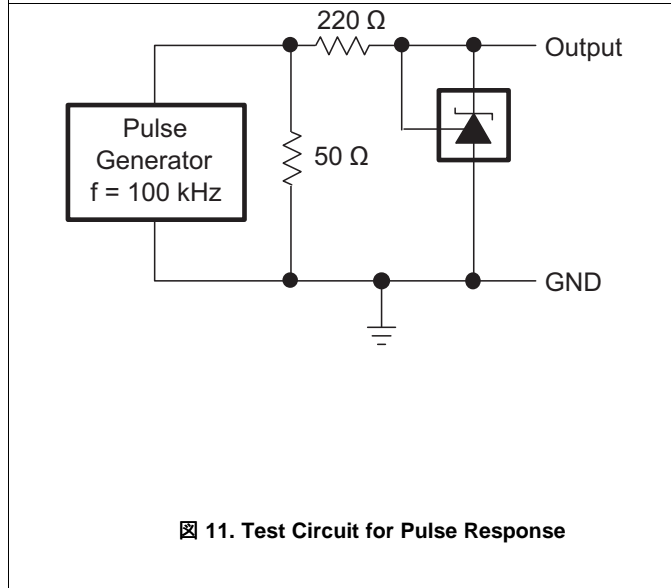
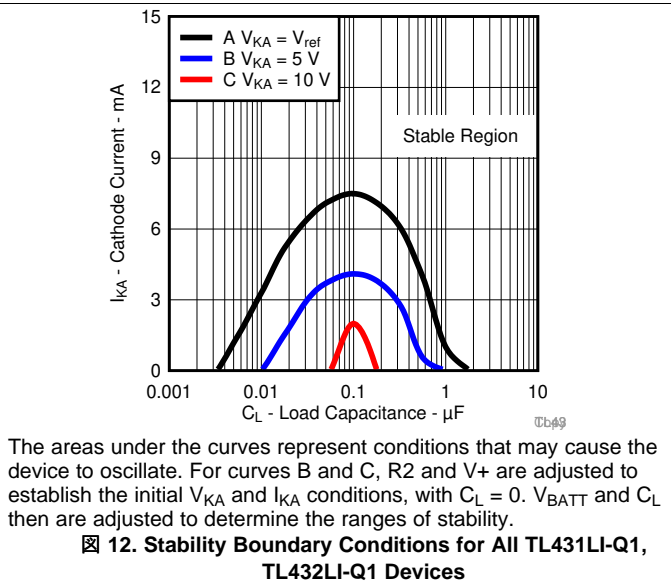

Fig. 11. Test Circuit for Pulse Response



The areas under the curves represent conditions that may cause the device to oscillate. For curves B and C, R2 and V+ are adjusted to establish the initial V_{KA} and I_{KA} conditions, with $C_L = 0$. V_{BATT} and C_L then are adjusted to determine the ranges of stability.

Fig. 12. Stability Boundary Conditions for All TL431LI-Q1, TL432LI-Q1 Devices

Typical Characteristics (continued)

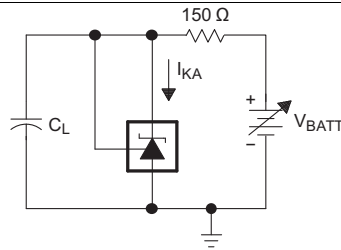

TEST CIRCUIT FOR CURVE A

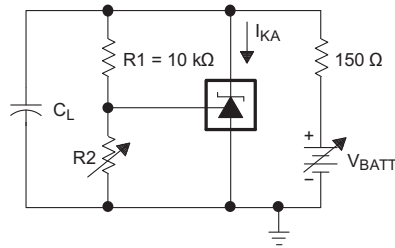

TEST CIRCUIT FOR CURVES B, C, AND D

✶ 13. Test Circuits for Stability Boundary Conditions

8 Parameter Measurement Information

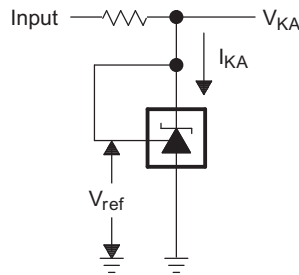

Figure 14. Test Circuit for $V_{KA} = V_{ref}$

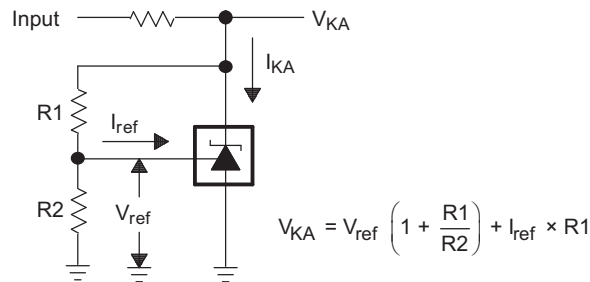

Figure 15. Test Circuit for $V_{KA} > V_{ref}$

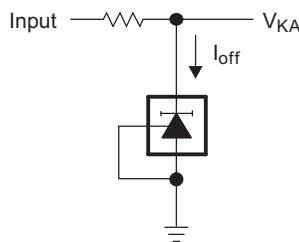

Figure 16. Test Circuit for I_{off}

8.1 Temperature Coefficient

The deviation of the reference voltage, V_{ref} , over the full temperature range is known as $V_{I(dev)}$. The parameter of $V_{I(dev)}$ can be used to find the temperature coefficient of the device. The average full-range temperature coefficient of the reference input voltage, $\alpha_{V_{ref}}$, is defined as:

$$\left| \alpha_{V_{ref}} \right| \left(\frac{\text{ppm}}{^{\circ}\text{C}} \right) = \frac{\left(\frac{V_{I(dev)}}{V_{ref \text{ at } 25^{\circ}\text{C}}} \right) \times 10^6}{\Delta T_A}$$

where:

ΔT_A is the rated operating temperature range of the device.

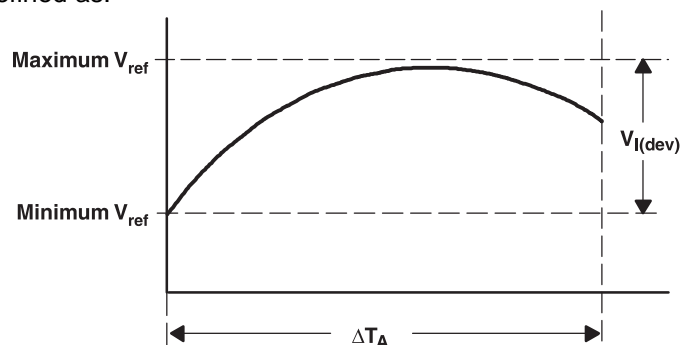

$\alpha_{V_{ref}}$ is positive or negative, depending on whether minimum V_{ref} or maximum V_{ref} , respectively, occurs at the lower temperature. The full-range temperature coefficient is an average and therefore any subsection of the rated operating temperature range can yield a value that is greater or less than the average. For more details on temperature coefficient, refer to the [Voltage Reference Selection Basics White Paper](#).

8.2 Dynamic Impedance

The dynamic impedance is defined as $|Z_{KA}| = \frac{\Delta V_{KA}}{\Delta I_{KA}}$. When the device is operating with two external resistors (see [Figure 15](#)), the total dynamic impedance of the circuit is given by $|z'| = \frac{\Delta V}{\Delta I}$, which is approximately equal to $|Z_{KA}| \left(1 + \frac{R1}{R2}\right)$.

The V_{KA} of the TL431LI-Q1 can be affected by the dynamic impedance. The TL431LI-Q1 test current I_{test} for V_{KA} is specified in the [Electrical Characteristics](#). Any deviation from I_{test} can cause deviation on the output V_{KA} . [Figure 17](#) shows the effect of the dynamic impedance on the V_{KA} .

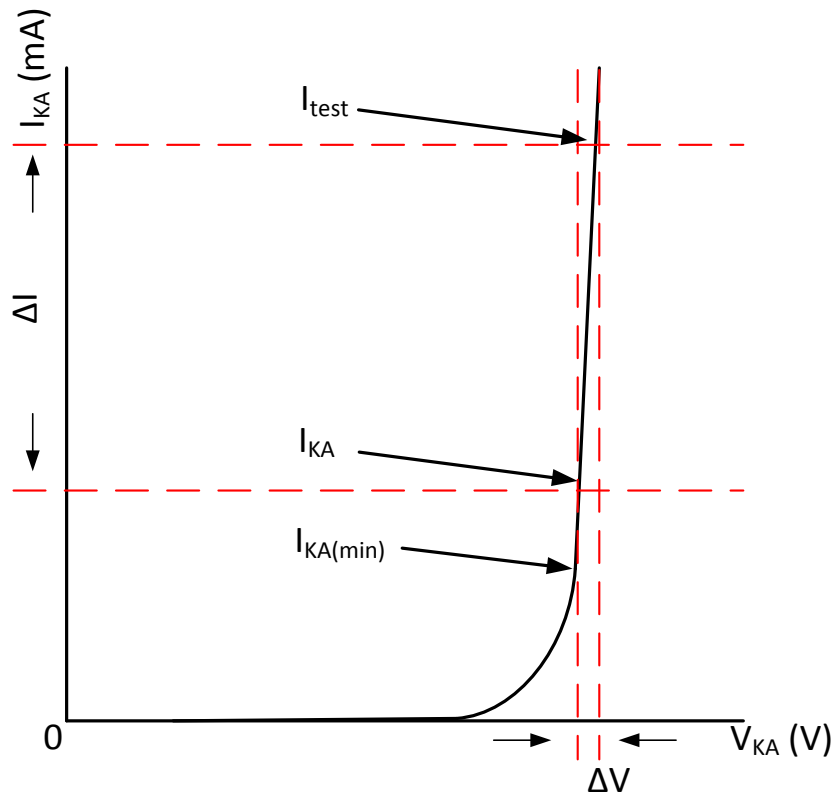

Figure 17. Dynamic Impedance

9 Detailed Description

9.1 Overview

This standard device has proven ubiquity and versatility across a wide range of applications, ranging from power to signal path. This is due to its key components containing an accurate voltage reference and op amp, which are very fundamental analog building blocks. TL43xLI-Q1 is used in conjunction with its key components to behave as a single voltage reference, error amplifier, voltage clamp or comparator with integrated reference.

TL43xLI-Q1 can be operated and adjusted to cathode voltages from 2.495 V to 36 V, making this part optimal for a wide range of end equipments in industrial, auto, telecom and computing. In order for this device to behave as a shunt regulator or error amplifier, $>0.6\text{mA}$ ($I_{\text{min(max)}}$) must be supplied in to the cathode pin. Under this condition, feedback can be applied from the Cathode and Ref pins to create a replica of the internal reference voltage.

Various reference voltage options can be purchased with initial tolerances (at 25°C) of 0.5% (denoted by B), and 1% (denoted by A). TL431LI-Q1 and TL432LI-Q1 are both functionally the same, but have different pinout options.

9.2 Functional Block Diagram



图 18. Equivalent Schematic



图 19. Detailed Schematic

9.3 Feature Description

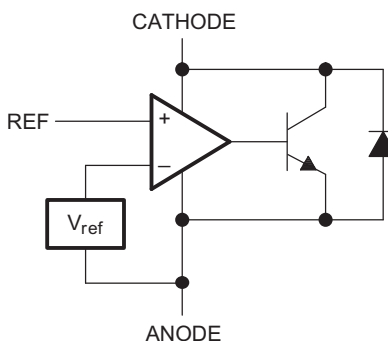
TL43xLI-Q1 consists of an internal reference and amplifier that outputs a sink current based on the difference between the reference pin and the virtual internal pin. The sink current is produced by the internal Darlington pair, shown in [Figure 19](#). A Darlington pair is used for this device to be able to sink a maximum current of 15 mA.

When operated with enough voltage headroom (≥ 2.495 V) and cathode current (I_{KA}), TL43xLI-Q1 forces the reference pin to 2.495 V. However, the reference pin can not be left floating, as it needs $I_{REF} \geq 0.4$ μ A (see the [Specifications](#)). This is because the reference pin is driven into an npn, which needs base current in order to operate properly.

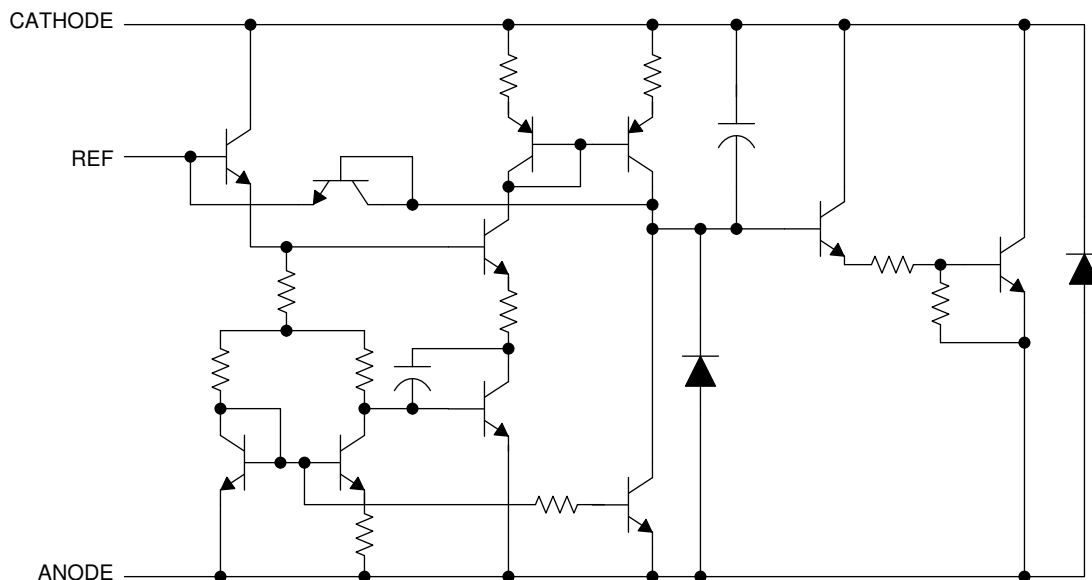
When feedback is applied from the Cathode and Reference pins, TL43xLI-Q1 behaves as a Zener diode (refer to [Figure 23](#) for a circuit example), regulating to a constant voltage dependent on current being supplied into the cathode. This is due to the internal amplifier and reference entering the proper operating regions. The same amount of current needed in the above feedback situation must be applied to this device in open loop, servo, or error amplifying implementations for it to be in the proper linear region giving TL43xLI-Q1 enough gain.

Unlike many linear regulators, TL43xLI-Q1 is internally compensated to be stable without an output capacitor between the cathode and anode. However, if it is desired to use an output capacitor, [Figure 12](#) can be used as a guide to assist in choosing the correct capacitor to maintain stability.

9.4 Device Functional Modes

9.4.1 Open Loop (Comparator)

When the cathode/output voltage or current of TL43xLI-Q1 is not being fed back to the reference/input pin in any form, this device is operating in open loop. With proper cathode current (I_{KA}) applied to this device, TL43xLI-Q1 has the characteristics shown in [Figure 18](#). With such high gain in this configuration, TL43xLI-Q1 is typically used as a comparator. Since the reference is integrated, TL43xLI-Q1 is the preferred choice when users are trying to monitor a certain level of a single signal. Refer to the [Using the TL431 as a Voltage Comparator Application Report](#) for more details on open loop comparator applications on the TL431LI-Q1.

9.4.2 Closed Loop

When the cathode/output voltage or current of TL43xLI-Q1 is being fed back to the reference/input pin in any form, this device is operating in closed loop. The majority of applications involving TL43xLI-Q1 use it in this manner to regulate a fixed voltage or current. The feedback enables this device to behave as an error amplifier, computing a portion of the output voltage and adjusting it to maintain the desired regulation. This is done by relating the output voltage back to the reference pin in a manner to make it equal to the internal reference voltage, which can be accomplished through resistive or direct feedback.

10 Applications and Implementation

注

Information in the following applications sections is not part of the TI component specification, and TI does not warrant its accuracy or completeness. TI's customers are responsible for determining suitability of components for their purposes. Customers should validate and test their design implementation to confirm system functionality.

10.1 Application Information

As this device has many applications and setups, there are many situations that this data sheet can not characterize in detail. The linked application notes help the designer make the best choices when using this part.

[Designing with the Improved TL431LI Application Note](#) provides a deeper understanding of this accuracy of the device in a flyback optocoupler application. [Setting the Shunt Voltage on an Adjustable Shunt Regulator Application Note](#) assists designers in setting the shunt voltage to achieve optimum accuracy for this device.

10.2 Typical Applications

10.2.1 Comparator With Integrated Reference

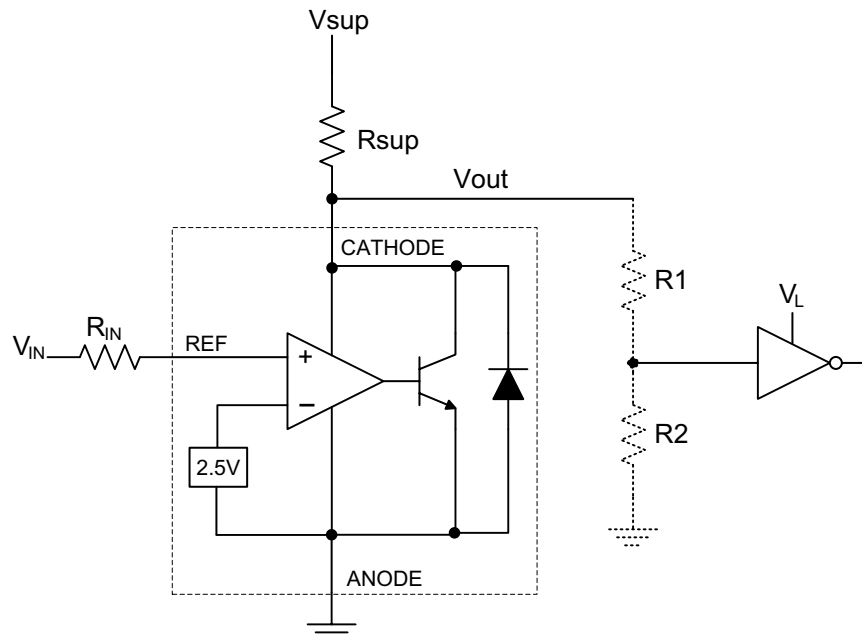

☒ 20. Comparator Application Schematic

Typical Applications (continued)

10.2.2 Design Requirements

For this design example, use the parameters listed in 表 1 as the input parameters.

表 1. Design Parameters

DESIGN PARAMETER	EXAMPLE VALUE
Input Voltage Range	0 V to 5 V
Input Resistance	10 kΩ
Supply Voltage	24 V
Cathode Current (I _k)	5 mA
Output Voltage Level	~2 V – V _{SUP}
Logic Input Thresholds V _{IH} /V _{IL}	V _L

10.2.3 Detailed Design Procedure

When using TL43xLI-Q1 as a comparator with reference, determine the following:

- Input voltage range
- Reference voltage accuracy
- Output logic input high and low level thresholds
- Current source resistance

10.2.3.1 Basic Operation

In the configuration shown in 図 20, TL43xLI-Q1 behaves as a comparator, comparing the V_{REF} pin voltage to the internal virtual reference voltage. When provided a proper cathode current (I_k), TL43xLI-Q1 has enough open loop gain to provide a quick response. This can be seen in 図 21 where the R_{SUP} = 10 kΩ (I_{KA} = 500 μA) situation responds much slower than R_{SUP} = 1 kΩ (I_{KA} = 5 mA). With the TL43xLI-Q1 max operating current (I_{MIN}) being 1 mA, operation below that can result in low gain, leading to a slow response.

10.2.3.1.1 Overdrive

Slow or inaccurate responses can also occur when the reference pin is not provided enough overdrive voltage. This is the amount of voltage that is higher than the internal virtual reference. The internal virtual reference voltage is within the range of 2.495 V ±(0.5% or 1.0%), depending on which version is being used. The more overdrive voltage provided, the faster the TL43xLI-Q1 responds.

For applications where TL43xLI-Q1 is being used as a comparator, it is best to set the trip point to greater than the positive expected error (that is +1.0% for the A version). For fast response, setting the trip point to >10% of the internal V_{REF} suffices.

For minimal voltage drop or difference from Vin to the ref pin, TI recommends to use an input resistor <10 kΩ to provide I_{ref}.

10.2.3.2 Output Voltage and Logic Input Level

For TL43xLI-Q1 to properly be used as a comparator, the logic output must be readable by the receiving logic device. This is accomplished by knowing the input high and low level threshold voltage levels, typically denoted by V_{IH} and V_{IL} .

As seen in [Figure 21](#), the output low level voltage of the TL43xLI in open-loop/comparator mode is approximately 2 V, which is typically sufficient for 5 V supplied logic. However, this does not work for 3.3 V and 1.8 V supplied logic. To accommodate this, a resistive divider can be tied to the output to attenuate the output voltage to a voltage legible to the receiving low voltage logic device.

The output high voltage of the TL43xLI is equal to V_{SUP} due to TL43xLI-Q1 being open-collector. If V_{SUP} is much higher than the maximum input voltage tolerance of the maximum logic, the output must be attenuated to accommodate the reliability of the outgoing logic.

When using a resistive divider on the output, make sure the sum of the resistive divider (R_1 and R_2 in [Figure 20](#)) is much greater than R_{SUP} to not interfere with the ability of the TL43xLI to pull close to V_{SUP} when turning off.

10.2.3.2.1 Input Resistance

TL43xLI-Q1 requires an input resistance in this application to source the reference current (I_{REF}) needed from this device to be in the proper operating regions while turning on. The actual voltage seen at the ref pin is $V_{REF} = V_{IN} - I_{REF}R_{IN}$. Because I_{REF} can be as high as 0.4 μA , it is recommended to use a resistance small enough that mitigates the error that I_{REF} creates from V_{IN} .

10.2.4 Application Curves

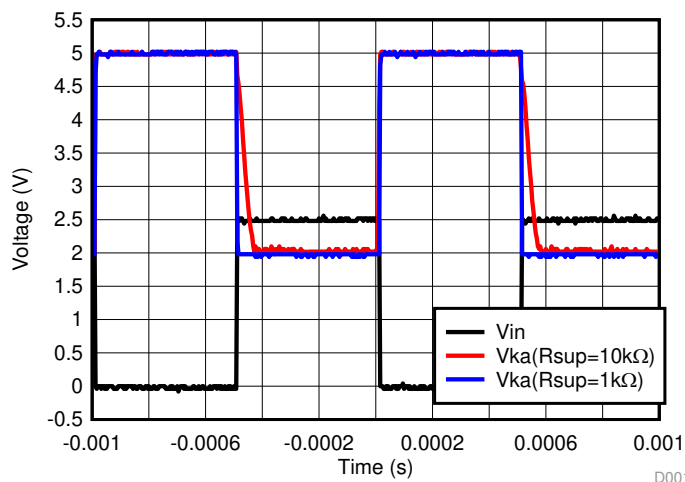

Figure 21. Output Response With Various Cathode Currents

10.2.5 Precision LED Lighting Current Sink Regulator



图 22. LED Lighting Current Sink Regulator

10.2.5.1 Design Requirements

For this design example, use the parameters listed in 表 1 as the input parameters.

表 2. Design Parameters

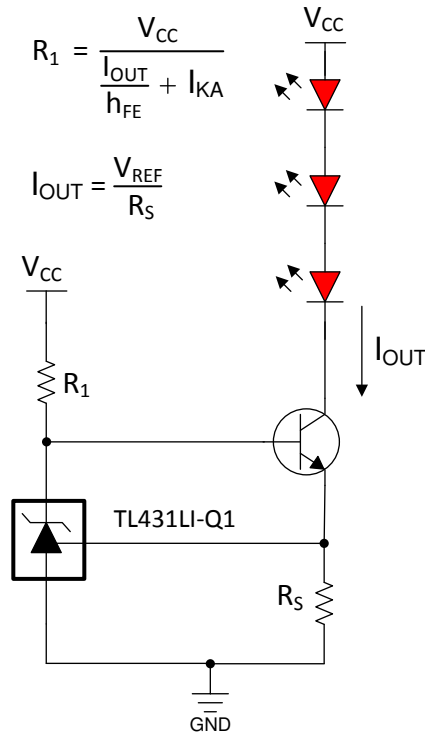
DESIGN PARAMETER	EXAMPLE VALUE
Supply Voltage ($V_{I(BATT)}$)	5 V
Sink Current (I_O)	100mA
Cathode Current (I_K)	5 mA

10.2.5.2 Detailed Design Procedure

When using the TL43xLI-Q1 as a constant current sink, determine the following:

- Output current range
- Output current accuracy
- Power consumption for TL43xLI-Q1

10.2.5.2.1 Basic Operation

In the configuration shown, TL43xLI-Q1 acts as a control component within a feedback loop of the constant current sink. Working with an external passing component such as a BJT, TL43xLI-Q1 provides precision current sink with accuracy set by itself and the sense resistor R_S . The LEDs are lit based on the desired current sink and regulated for accurate brightness and color.

10.2.5.2.1.1 Output Current Range and Accuracy

The output current range of the circuit is determined by the equation shown in the configuration. Keep in mind that the V_{REF} equals to 2.495 V. When choosing the sense resistor R_S , it needs to generate 2.495 V for the TL43xLI-Q1 when I_O reaches the target current. If the overhead voltage of 2.495 V is not acceptable, consider lower voltage reference devices such as the TLV43x-Q1 or TLVH43x-Q1.

The output current accuracy is determined by both the accuracy of TL43xLI-Q1 chosen, as well as the accuracy of the sense resistor R_S . The internal virtual reference voltage of TL43xLI-Q1 is within the range of 2.495 V \pm (0.5% or 1.0%), depending on which version is being used. Another consideration for the output current accuracy is the temperature coefficient of the TL43xLI-Q1 and R_S . Refer to the [Electrical Characteristics](#) of these parameters.

10.2.5.2.2 Power Consumption

For TL43xLI-Q1 to properly be used as a control component in this circuit, the minimum operating current needs to be reached. This is accomplished by setting the external biasing resistor in series with the TL43xLI-Q1.

For TL43xLI, the minimum operating current is 0.6 mA and with margin consideration, most of the designs set this current to be higher than 0.6 mA. To achieve lower power consumption, consider devices such as the ATL43x-Q1 and ATL43xLI-Q1.

10.2.6 Shunt Regulator/Reference



图 23. Shunt Regulator Schematic

10.2.6.1 Design Requirements

For this design example, use the parameters listed in 表 1 as the input parameters.

表 3. Design Parameters

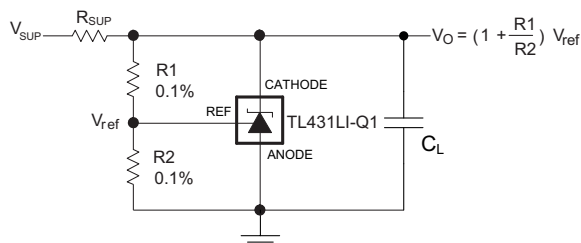
DESIGN PARAMETER	EXAMPLE VALUE
Reference Initial Accuracy	1.0%
Supply Voltage	24 V
Cathode Current (I _k)	5 mA
Output Voltage Level	2.495 V–36 V
Load Capacitance	2 μF
Feedback Resistor Values and Accuracy (R1 and R2)	10 kΩ

10.2.6.2 Detailed Design Procedure

When using TL43xLI-Q1 as a shunt regulator, determine the following:

- Input voltage range
- Temperature range
- Total accuracy
- Cathode current
- Reference initial accuracy
- Output capacitance

10.2.6.2.1 Programming Output/Cathode Voltage

To program the cathode voltage to a regulated voltage, a resistive bridge must be shunted between the cathode and anode pins with the mid point tied to the reference pin. This can be seen in 图 23, with R1 and R2 being the resistive bridge. The cathode/output voltage in the shunt regulator configuration can be approximated by the equation shown in 图 23. The cathode voltage can be more accurately determined by taking in to account the cathode current:

$$V_O = (1 + R1/R2)V_{REF} - I_{REF}R1 \quad (1)$$

For this equation to be valid, TL43xLI-Q1 must be fully biased so that it has enough open loop gain to mitigate any gain error. This can be done by meeting the I_{min} spec denoted in the [Specifications](#).

10.2.6.2.2 Total Accuracy

When programming the output above unity gain ($V_{KA}=V_{REF}$), TL43xLI-Q1 is susceptible to other errors that can effect the overall accuracy beyond V_{REF} . These errors include:

- R1 and R2 accuracies
- $V_{I(dev)}$: Change in reference voltage over temperature
- $\Delta V_{REF} / \Delta V_{KA}$: Change in reference voltage to the change in cathode voltage
- $|Z_{KA}|$ - Dynamic impedance, causing a change in cathode voltage with cathode current

Worst case cathode voltage can be determined taking all of the variables in to account. The [Setting the Shunt Voltage on an Adjustable Shunt Regulator Application Note](#) assists designers in setting the shunt voltage to achieve optimum accuracy for this device.

10.2.6.2.3 Stability

Though TL43xLI-Q1 is stable with no capacitive load, the device that receives the output voltage of the shunt regulator can presents a capacitive load that is within the TL43xLI-Q1 region of stability, shown in [Figure 12](#). Also, designers can use capacitive loads to improve the transient response or for power supply decoupling. When using additional capacitance between Cathode and Anode, refer to [Figure 12](#). Also, the [Understanding Stability Boundary Conditions Charts in TL431, TL432 Data Sheet Application Note](#) provides a deeper understanding of this devices stability characteristics and aids the user in making the right choices when choosing a load capacitor.

10.2.6.2.4 Start-up Time

As shown in [Figure 24](#), TL43xLI-Q1 has a fast response up to approximately 2 V and then slowly charges to the programmed value. This is due to the compensation capacitance (shown in [Figure 19](#)) the TL43xLI-Q1 has to meet the stability criteria. Despite the secondary delay, TL43xLI-Q1 still has a fast response suitable for many clamp applications.

10.2.6.3 Application Curves

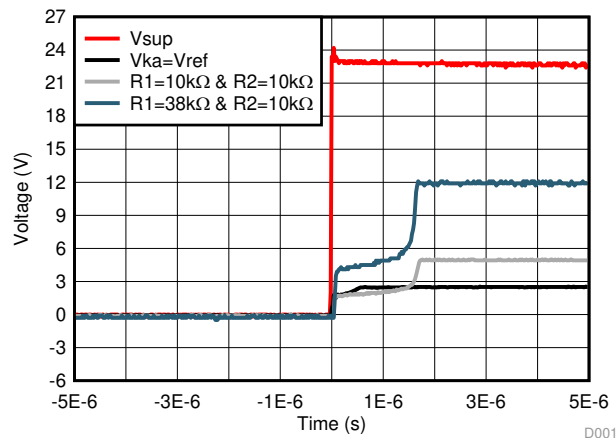

Figure 24. TL43xLI-Q1 Start-Up Response

10.2.7 Isolated Flyback with Optocoupler



图 25. Isolated Flyback with Optocoupler

10.2.7.1 Design Requirements

The TL431LI-Q1 is used in the feedback network on the secondary side in an isolated flyback with optocoupler design. 图 25 shows the simplified flyback converter with the TL431LI-Q1. For this design example, use the parameters in 表 4 as the input parameters. In this example, a simplified design procedure will be discussed. The compensation network for the feedback network is beyond the scope of this section. Details on compensation network can be found in the [Compensation Design with TL431 for UCC28600 Application Report](#).

表 4. Design Parameters

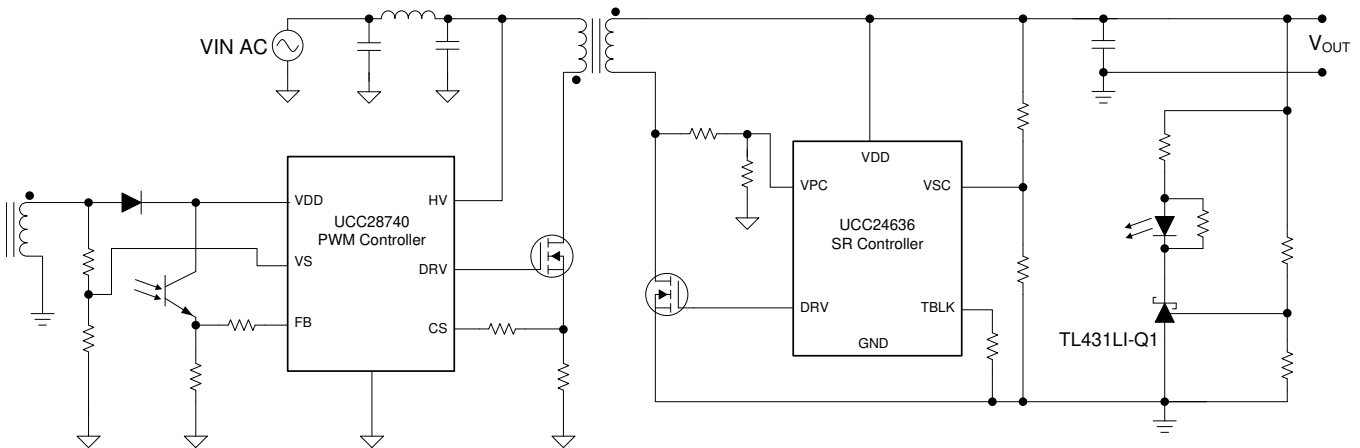
DESIGN PARAMETER	EXAMPLE VALUE
Voltage Output	15 V
Secondary Side Feedback Loop Accuracy	< 3%

10.2.7.2 Detailed Design Procedure

The goal of this design is to design a high accuracy feedback network to meet 3% V_{OUT} accuracy requirements over the full temperature range. To meet the design requirements, the total secondary side feedback loop error has to be below 3%. To meet these requirements, it is necessary to take full advantage of the improved temperature drift, $I_{ref(min)}$, and $I_{I(dev)}$ of the TL431LI-Q1.



图 26. Feedback Quiescent Current

10.2.7.2.1 TL431 Feedback Loop Error Calculation

Figure 26 shows the simplified version of the feedback network. The accuracy of the output voltage is dependent on the regulation voltage accuracy of the TL431LI-Q1. A simplified V_{OUT} can be seen in Equation 2, but this equation does not include errors that deviates the output.

$$V_{OUT} = V_{ref} \times \left(1 + \frac{R1}{R2}\right) + R1 \times (I_{ref})$$

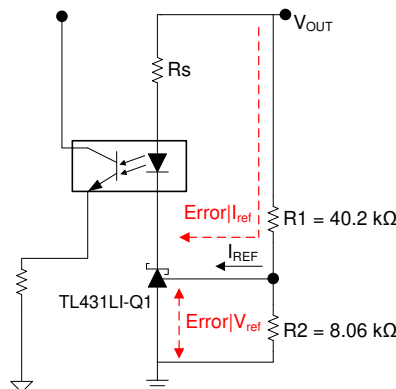
$$V_{OUT} = (2.495 \text{ V}) \times \left(1 + \frac{40.2 \text{ k}\Omega}{8.06 \text{ k}\Omega}\right) + 40.2 \text{ k}\Omega \times (0.4 \mu\text{A})$$

$$V_{OUT} = 14.955 \text{ V} \tag{2}$$

The primary sources of error are the $\text{Error}|_{V_{ref}}$ and $\text{Error}|_{I_{ref}}$. The $\text{Error}|_{V_{ref}}$ primarily consists of the errors that affect the internal bandgap voltage reference of the TL431LI-Q1. This consists of errors from the initial accuracy, temperature drift, ratio of change in reference voltage to the change in cathode voltage, and dynamic impedance. The benefit of the TL431LI-Q1 is its low temperature drift, $V_{I(dev)}$, which allows the V_{ref} to be more accurate across the full temperature range compared to typical TL431LI-Q1 devices. Equation 3 shows a simplified worst case V_{ref} with initial accuracy and temperature drift.

$$V_{ref}(\text{Error}|_{V_{ref}}) = V_{ref} \times (1 + \text{Initial Accuracy}) + V_{I(dev)} + \dots$$

$$V_{ref}(\text{Error}|_{V_{ref}}) = 2.495 \text{ V} \times (1 + 0.5\%) + 17 \text{ mV} + \dots$$

$$V_{ref}(\text{Error}|_{V_{ref}}) \approx 2.524 \text{ V} \tag{3}$$

The $\text{Error}|_{I_{ref}}$ in Figure 26 is dependent on the I_{ref} and $I_{I(dev)}$ along with R1. The TL431LI-Q1 has improved I_{ref} and $I_{I(dev)}$ which allows the values of the resistor R1 to be increased to save power. Typically optocoupler feedback design requires the I_{ref} to be taken into account when doing V_{OUT} calculations but the error comes from the deviation from the maximum to typical value of I_{ref} . In addition to this, the $I_{I(dev)}$ is the temperature deviation on the I_{ref} current which affects the overall reference current into the TL431LI-Q1. Equation 4 shows the V_{OUT} of the TL431LI-Q1 for Figure 26, which includes the improved I_{ref} and $I_{I(dev)}$. The V_{OUT} equation assumes that the resistors R1 and R2 have a 0.5% accuracy tolerance.

$$V_{OUT}(\text{Error}|_{I_{ref}}) = V_{ref}(\text{Error}|_{V_{ref}}) \times \left(1 + \frac{R1}{R2}\right) + R1 \times (I_{ref} + I_{I(dev)})$$

$$V_{OUT}(\text{Error}|_{I_{ref}}) = (2.495 \text{ V} \times (1 + 0.5\%) + 0.017 \text{ V}) \times \left(1 + \frac{40.2 \text{ k}\Omega \times (1 + 0.5\%)}{8.06 \text{ k}\Omega \times (1 - 0.5\%)}\right)$$

$$+ 40.2 \text{ k}\Omega \times (1 + 0.5\%) \times (0.4 \mu\text{A} + 0.3 \mu\text{A})$$

$$V_{OUT} = 15.270 \text{ V} \tag{4}$$

Comparing the calculated V_{OUT} without and with error, the expected worst case max error is 2.1% which meets the 3% error target.

10.3 System Examples

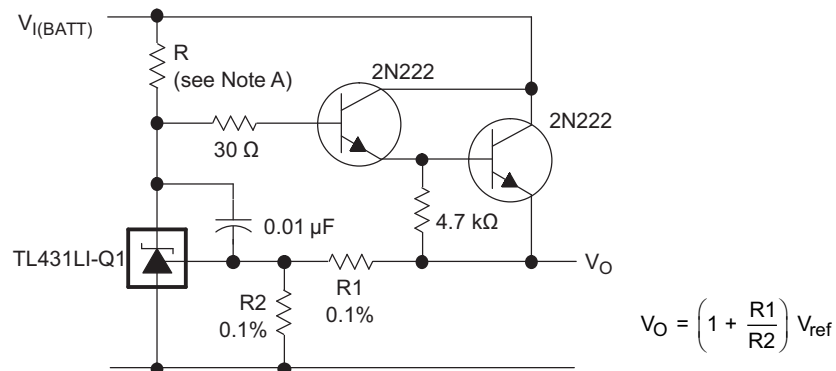

R should provide cathode current ≥ 0.6 mA to the TL431LI-Q1 at minimum $V_{I(BATT)}$.

☒ 27. Precision High-Current Series Regulator

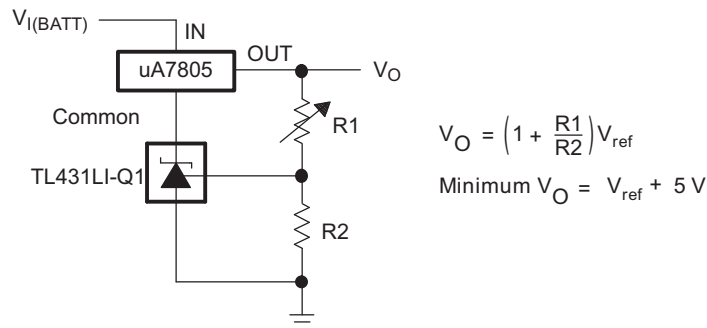

☒ 28. Output Control of a Three-Terminal Fixed Regulator

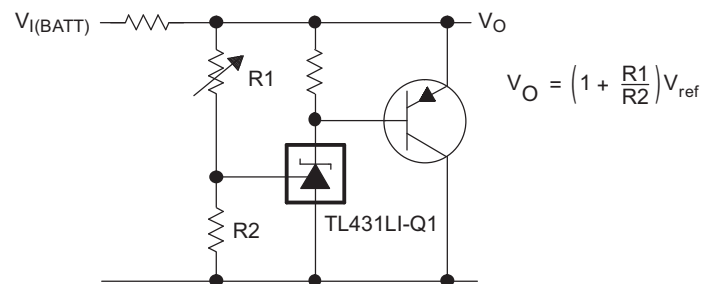

☒ 29. High-Current Shunt Regulator

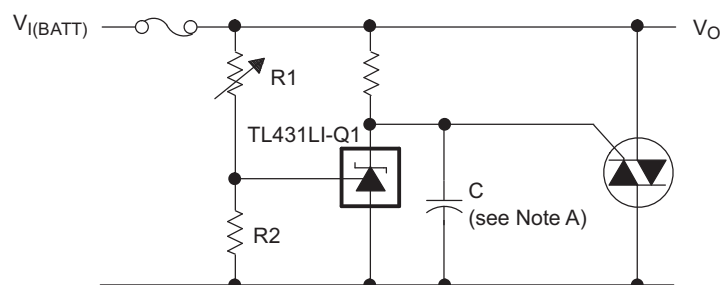

Refer to the stability boundary conditions in ☒ 12 to determine allowable values for C.

☒ 30. Crowbar Circuit

System Examples (continued)

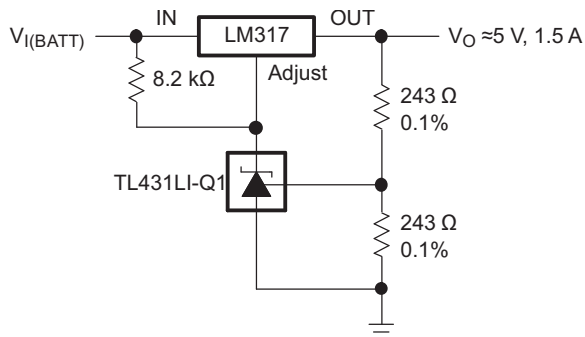
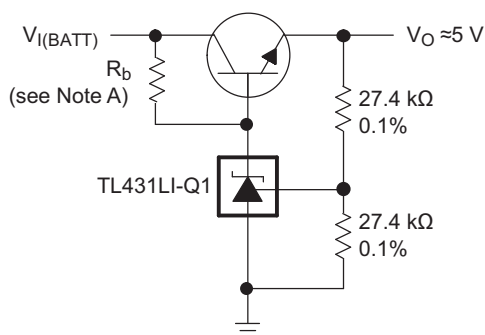

Figure 31. Precision 5-V, 1.5-A Regulator



R_b should provide cathode current ≥ 0.6 mA to the TL431LI-Q1.

Figure 32. Efficient 5-V Low-Dropout (LDO) Regulator Configuration

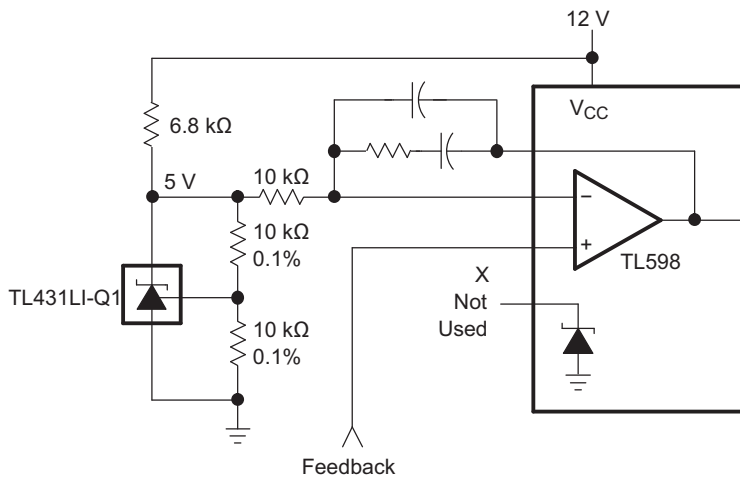
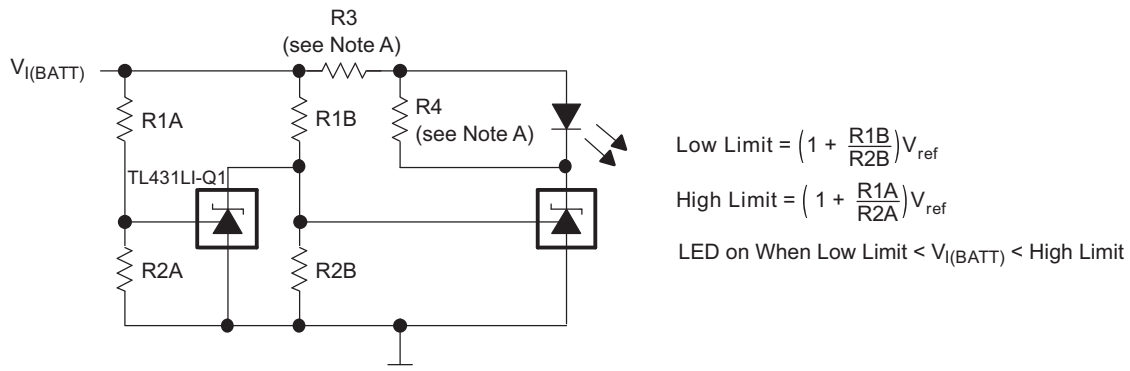

Figure 33. PWM Converter With Reference

System Examples (continued)



Select R3 and R4 to provide the desired LED intensity and cathode current ≥ 0.6 mA to the TL431LI-Q1 at the available $V_{I(BATT)}$.

FIG 34. Voltage Monitor

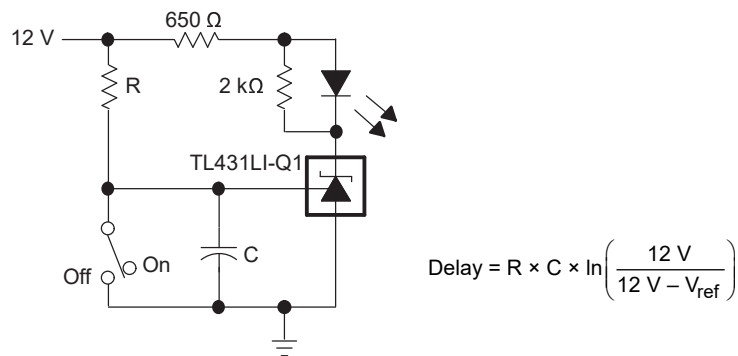

FIG 35. Delay Timer

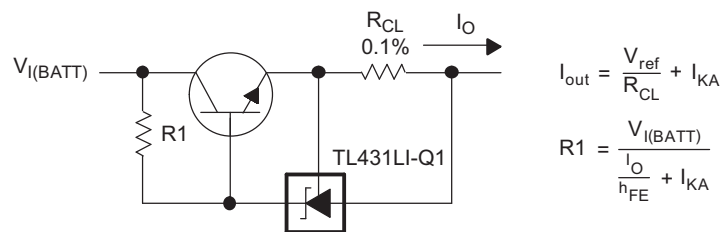

FIG 36. Precision Current Limiter

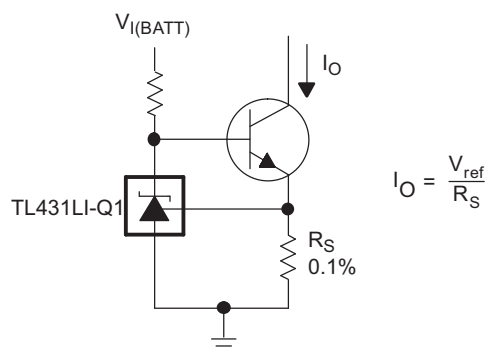

FIG 37. Precision Constant-Current Sink

11 Power Supply Recommendations

When using TL43xLI-Q1 as a Linear Regulator to supply a load, designers typically use a bypass capacitor on the output/cathode pin. When doing this, be sure that the capacitance is within the stability criteria shown in [12](#).

To not exceed the maximum cathode current, be sure that the supply voltage is current limited. Also, be sure to limit the current being driven into the Ref pin, as not to exceed the absolute maximum rating.

For applications shunting high currents, pay attention to the cathode and anode trace lengths, adjusting the width of the traces to have the proper current density.

12 Layout

12.1 Layout Guidelines

Bypass capacitors must be placed as close to the part as possible. Current-carrying traces need to have widths appropriate for the amount of current they are carrying; in the case of the TL43xLI-Q1, these currents are low.

12.2 Layout Example

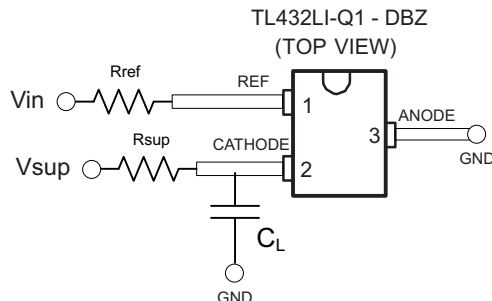

38. DBZ Layout Example

13 デバイスおよびドキュメントのサポート

13.1 デバイス・サポート

13.1.1 デバイスの項目表記

TI は、TL43xLI-Q1 ファミリのすべての組み合わせを区別するために、接尾辞と接頭辞を割り当てています。詳細および注文可能な組み合わせについては、「付録:パッケージ・オプション」を参照してください。

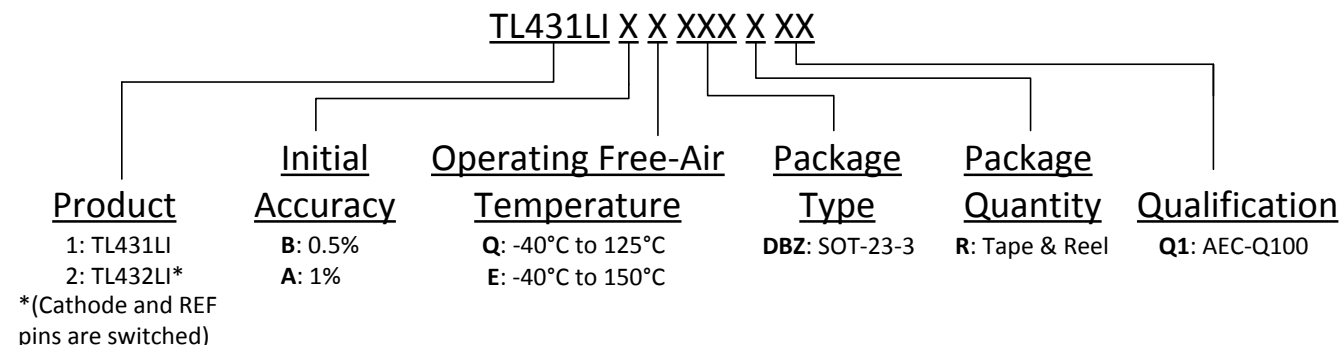

13.2 ドキュメントのサポート

13.2.1 関連資料

関連資料については、以下を参照してください。

- テキサス・インスツルメンツ、『[Understanding Stability Boundary Conditions Charts in TL431, TL432 Data Sheet](#)』 (英語)
- テキサス・インスツルメンツ、『[Setting the Shunt Voltage on an Adjustable Shunt Regulator](#)』 (英語)
- テキサス・インスツルメンツ、『[Designing with the Improved TL431LI](#)』 (英語)

13.3 関連リンク

次の表に、クイック・アクセス・リンクを示します。カテゴリには、技術資料、サポートおよびコミュニティ・リソース、ツールとソフトウェア、およびご注文へのクイック・アクセスが含まれます。

表 5. 関連リンク

製品	プロダクト・フォルダ	ご注文はこちら	技術資料	ツールとソフトウェア	サポートとコミュニティ
TL431LI-Q1	ここをクリック	ここをクリック	ここをクリック	ここをクリック	ここをクリック
TL432LI-Q1	ここをクリック	ここをクリック	ここをクリック	ここをクリック	ここをクリック

13.4 ドキュメントの更新通知を受け取る方法

ドキュメントの更新についての通知を受け取るには、[ti.com](#)のデバイス製品フォルダを開いてください。右上の「アラートを受け取る」をクリックして登録すると、変更されたすべての製品情報に関するダイジェストを毎週受け取れます。変更の詳細については、修正されたドキュメントに含まれている改訂履歴をご覧ください。

13.5 サポート・リソース

[TI E2E™ support forums](#) are an engineer's go-to source for fast, verified answers and design help — straight from the experts. Search existing answers or ask your own question to get the quick design help you need.

Linked content is provided "AS IS" by the respective contributors. They do not constitute TI specifications and do not necessarily reflect TI's views; see TI's [Terms of Use](#).

13.6 商標

E2E is a trademark of Texas Instruments.
All other trademarks are the property of their respective owners.

13.7 静電気放電に関する注意事項



すべての集積回路は、適切なESD保護方法を用いて、取扱いと保存を行うようにして下さい。

静電気放電はわずかな性能の低下から完全なデバイスの故障に至るまで、様々な損傷を与えます。高精度の集積回路は、損傷に対して敏感であり、極めてわずかなパラメータの変化により、デバイスに規定された仕様に適合しなくなる場合があります。

13.8 Glossary

[SLYZ022](#) — *TI Glossary*.

This glossary lists and explains terms, acronyms, and definitions.

14 メカニカル、パッケージ、および注文情報

以降のページには、メカニカル、パッケージ、および注文に関する情報が記載されています。この情報は、そのデバイスについて利用可能な最新のデータです。このデータは予告なく変更されることがあり、ドキュメントが改訂される場合もあります。本データシートのブラウザ版を使用されている場合は、画面左側の説明をご覧ください。

PACKAGING INFORMATION

Orderable part number	Status (1)	Material type (2)	Package Pins	Package qty Carrier	RoHS (3)	Lead finish/ Ball material (4)	MSL rating/ Peak reflow (5)	Op temp (°C)	Part marking (6)
TL431LIAEDBZRQ1	Active	Production	SOT-23 (DBZ) 3	3000 LARGE T&R	Yes	NIPDAU	Level-1-260C-UNLIM	-40 to 150	23CP
TL431LIAEDBZRQ1.B	Active	Production	SOT-23 (DBZ) 3	3000 LARGE T&R	Yes	NIPDAU	Level-1-260C-UNLIM	-40 to 150	23CP
TL431LIAQDBZRQ1	Active	Production	SOT-23 (DBZ) 3	3000 LARGE T&R	Yes	NIPDAU	Level-1-260C-UNLIM	-40 to 125	22TP
TL431LIAQDBZRQ1.B	Active	Production	SOT-23 (DBZ) 3	3000 LARGE T&R	Yes	NIPDAU	Level-1-260C-UNLIM	-40 to 125	22TP
TL431LIBEDBZRQ1	Active	Production	SOT-23 (DBZ) 3	3000 LARGE T&R	Yes	NIPDAU	Level-1-260C-UNLIM	-40 to 150	23DP
TL431LIBEDBZRQ1.B	Active	Production	SOT-23 (DBZ) 3	3000 LARGE T&R	Yes	NIPDAU	Level-1-260C-UNLIM	-40 to 150	23DP
TL431LIBQDBZRQ1	Active	Production	SOT-23 (DBZ) 3	3000 LARGE T&R	Yes	NIPDAU	Level-1-260C-UNLIM	-40 to 125	22UP
TL431LIBQDBZRQ1.B	Active	Production	SOT-23 (DBZ) 3	3000 LARGE T&R	Yes	NIPDAU	Level-1-260C-UNLIM	-40 to 125	22UP
TL432LIAEDBZRQ1	Active	Production	SOT-23 (DBZ) 3	3000 LARGE T&R	Yes	NIPDAU	Level-1-260C-UNLIM	-40 to 150	23EP
TL432LIAEDBZRQ1.B	Active	Production	SOT-23 (DBZ) 3	3000 LARGE T&R	Yes	NIPDAU	Level-1-260C-UNLIM	-40 to 150	23EP
TL432LIAQDBZRQ1	Active	Production	SOT-23 (DBZ) 3	3000 LARGE T&R	Yes	NIPDAU	Level-1-260C-UNLIM	-40 to 125	22VP
TL432LIAQDBZRQ1.B	Active	Production	SOT-23 (DBZ) 3	3000 LARGE T&R	Yes	NIPDAU	Level-1-260C-UNLIM	-40 to 125	22VP
TL432LIBEDBZRQ1	Active	Production	SOT-23 (DBZ) 3	3000 LARGE T&R	Yes	NIPDAU	Level-1-260C-UNLIM	-40 to 150	23FP
TL432LIBEDBZRQ1.B	Active	Production	SOT-23 (DBZ) 3	3000 LARGE T&R	Yes	NIPDAU	Level-1-260C-UNLIM	-40 to 150	23FP
TL432LIBQDBZRQ1	Active	Production	SOT-23 (DBZ) 3	3000 LARGE T&R	Yes	NIPDAU	Level-1-260C-UNLIM	-40 to 125	22WP
TL432LIBQDBZRQ1.B	Active	Production	SOT-23 (DBZ) 3	3000 LARGE T&R	Yes	NIPDAU	Level-1-260C-UNLIM	-40 to 125	22WP

(1) **Status:** For more details on status, see our [product life cycle](#).

(2) **Material type:** When designated, preproduction parts are prototypes/experimental devices, and are not yet approved or released for full production. Testing and final process, including without limitation quality assurance, reliability performance testing, and/or process qualification, may not yet be complete, and this item is subject to further changes or possible discontinuation. If available for ordering, purchases will be subject to an additional waiver at checkout, and are intended for early internal evaluation purposes only. These items are sold without warranties of any kind.

(3) **RoHS values:** Yes, No, RoHS Exempt. See the [TI RoHS Statement](#) for additional information and value definition.

(4) **Lead finish/Ball material:** Parts may have multiple material finish options. Finish options are separated by a vertical ruled line. Lead finish/Ball material values may wrap to two lines if the finish value exceeds the maximum column width.

(5) **MSL rating/Peak reflow:** The moisture sensitivity level ratings and peak solder (reflow) temperatures. In the event that a part has multiple moisture sensitivity ratings, only the lowest level per JEDEC standards is shown. Refer to the shipping label for the actual reflow temperature that will be used to mount the part to the printed circuit board.

(6) Part marking: There may be an additional marking, which relates to the logo, the lot trace code information, or the environmental category of the part.

Multiple part markings will be inside parentheses. Only one part marking contained in parentheses and separated by a "-" will appear on a part. If a line is indented then it is a continuation of the previous line and the two combined represent the entire part marking for that device.

Important Information and Disclaimer:The information provided on this page represents TI's knowledge and belief as of the date that it is provided. TI bases its knowledge and belief on information provided by third parties, and makes no representation or warranty as to the accuracy of such information. Efforts are underway to better integrate information from third parties. TI has taken and continues to take reasonable steps to provide representative and accurate information but may not have conducted destructive testing or chemical analysis on incoming materials and chemicals. TI and TI suppliers consider certain information to be proprietary, and thus CAS numbers and other limited information may not be available for release.

In no event shall TI's liability arising out of such information exceed the total purchase price of the TI part(s) at issue in this document sold by TI to Customer on an annual basis.

OTHER QUALIFIED VERSIONS OF TL431LI-Q1, TL432LI-Q1 :

- Catalog : [TL431LI](#), [TL432LI](#)

NOTE: Qualified Version Definitions:

- Catalog - TI's standard catalog product

TAPE AND REEL INFORMATION

QUADRANT ASSIGNMENTS FOR PIN 1 ORIENTATION IN TAPE

*All dimensions are nominal

Device	Package Type	Package Drawing	Pins	SPQ	Reel Diameter (mm)	Reel Width W1 (mm)	A0 (mm)	B0 (mm)	K0 (mm)	P1 (mm)	W (mm)	Pin1 Quadrant
TL431LIAEDBZRQ1	SOT-23	DBZ	3	3000	180.0	8.4	2.9	3.35	1.35	4.0	8.0	Q3
TL431LIAEDBZRQ1	SOT-23	DBZ	3	3000	178.0	9.0	3.15	2.77	1.22	4.0	8.0	Q3
TL431LIAQDBZRQ1	SOT-23	DBZ	3	3000	178.0	9.0	3.15	2.77	1.22	4.0	8.0	Q3
TL431LIBEDBZRQ1	SOT-23	DBZ	3	3000	180.0	8.4	2.9	3.35	1.35	4.0	8.0	Q3
TL431LIBEDBZRQ1	SOT-23	DBZ	3	3000	178.0	9.0	3.15	2.77	1.22	4.0	8.0	Q3
TL431LIBQDBZRQ1	SOT-23	DBZ	3	3000	178.0	9.0	3.15	2.77	1.22	4.0	8.0	Q3
TL432LIAEDBZRQ1	SOT-23	DBZ	3	3000	178.0	9.0	3.15	2.77	1.22	4.0	8.0	Q3
TL432LIAEDBZRQ1	SOT-23	DBZ	3	3000	180.0	8.4	2.9	3.35	1.35	4.0	8.0	Q3
TL432LIAQDBZRQ1	SOT-23	DBZ	3	3000	178.0	9.0	3.15	2.77	1.22	4.0	8.0	Q3
TL432LIBEDBZRQ1	SOT-23	DBZ	3	3000	178.0	9.0	3.15	2.77	1.22	4.0	8.0	Q3
TL432LIBEDBZRQ1	SOT-23	DBZ	3	3000	180.0	8.4	2.9	3.35	1.35	4.0	8.0	Q3
TL432LIBQDBZRQ1	SOT-23	DBZ	3	3000	178.0	9.0	3.15	2.77	1.22	4.0	8.0	Q3

TAPE AND REEL BOX DIMENSIONS

*All dimensions are nominal

Device	Package Type	Package Drawing	Pins	SPQ	Length (mm)	Width (mm)	Height (mm)
TL431LIAEDBZRQ1	SOT-23	DBZ	3	3000	210.0	185.0	35.0
TL431LIAEDBZRQ1	SOT-23	DBZ	3	3000	180.0	180.0	18.0
TL431LIAQDBZRQ1	SOT-23	DBZ	3	3000	180.0	180.0	18.0
TL431LIBEDBZRQ1	SOT-23	DBZ	3	3000	210.0	185.0	35.0
TL431LIBEDBZRQ1	SOT-23	DBZ	3	3000	180.0	180.0	18.0
TL431LIBQDBZRQ1	SOT-23	DBZ	3	3000	180.0	180.0	18.0
TL432LIAEDBZRQ1	SOT-23	DBZ	3	3000	180.0	180.0	18.0
TL432LIAEDBZRQ1	SOT-23	DBZ	3	3000	210.0	185.0	35.0
TL432LIAQDBZRQ1	SOT-23	DBZ	3	3000	180.0	180.0	18.0
TL432LIBEDBZRQ1	SOT-23	DBZ	3	3000	180.0	180.0	18.0
TL432LIBEDBZRQ1	SOT-23	DBZ	3	3000	210.0	185.0	35.0
TL432LIBQDBZRQ1	SOT-23	DBZ	3	3000	180.0	180.0	18.0

EXAMPLE BOARD LAYOUT

DBZ0003A

SOT-23 - 1.12 mm max height

SMALL OUTLINE TRANSISTOR

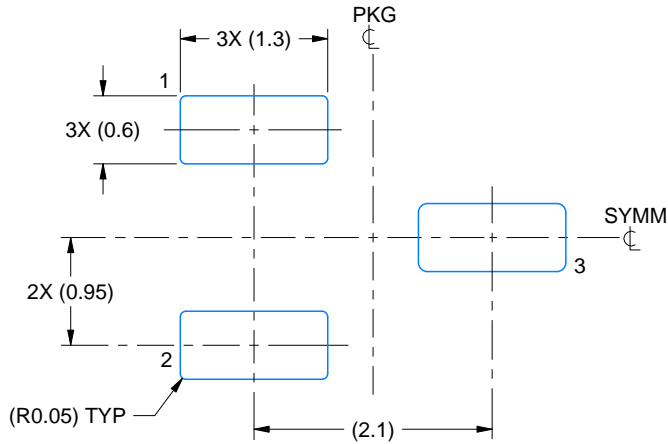

LAND PATTERN EXAMPLE
SCALE:15X

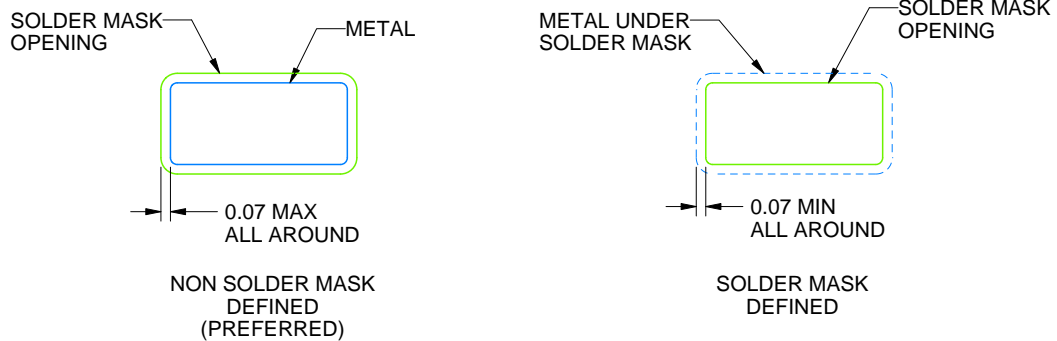

SOLDER MASK DETAILS

4214838/F 08/2024

NOTES: (continued)

5. Publication IPC-7351 may have alternate designs.
6. Solder mask tolerances between and around signal pads can vary based on board fabrication site.

EXAMPLE STENCIL DESIGN

DBZ0003A

SOT-23 - 1.12 mm max height

SMALL OUTLINE TRANSISTOR

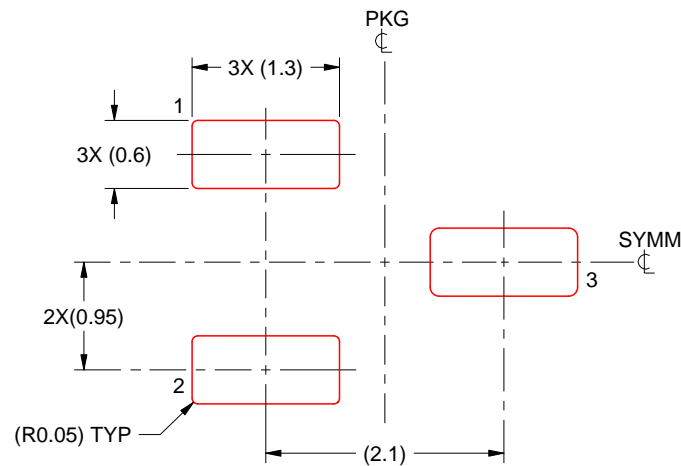

SOLDER PASTE EXAMPLE
BASED ON 0.125 THICK STENCIL
SCALE:15X

4214838/F 08/2024

NOTES: (continued)

7. Laser cutting apertures with trapezoidal walls and rounded corners may offer better paste release. IPC-7525 may have alternate design recommendations.
8. Board assembly site may have different recommendations for stencil design.

重要なお知らせと免責事項

TI は、技術データと信頼性データ (データシートを含みます)、設計リソース (リファレンス デザインを含みます)、アプリケーションや設計に関する各種アドバイス、Web ツール、安全性情報、その他のリソースを、欠陥が存在する可能性のある「現状のまま」提供しており、商品性および特定目的に対する適合性の黙示保証、第三者の知的財産権の非侵害保証を含むいかなる保証も、明示的または黙示的にかかわらず拒否します。

これらのリソースは、TI 製品を使用する設計の経験を積んだ開発者への提供を意図したものです。(1) お客様のアプリケーションに適した TI 製品の選定、(2) お客様のアプリケーションの設計、検証、試験、(3) お客様のアプリケーションに該当する各種規格や、その他のあらゆる安全性、セキュリティ、規制、または他の要件への確実な適合に関する責任を、お客様のみが単独で負うものとし、

上記の各種リソースは、予告なく変更される可能性があります。これらのリソースは、リソースで説明されている TI 製品を使用するアプリケーションの開発の目的でのみ、TI はその使用をお客様に許諾します。これらのリソースに関して、他の目的で複製することや掲載することは禁止されています。TI や第三者の知的財産権のライセンスが付与されている訳ではありません。お客様は、これらのリソースを自身で使用した結果発生するあらゆる申し立て、損害、費用、損失、責任について、TI およびその代理人を完全に補償するものとし、TI は一切の責任を拒否します。

TI の製品は、[TI の販売条件](#)、[TI の総合的な品質ガイドライン](#)、[ti.com](#) または TI 製品などに関連して提供される他の適用条件に従い提供されます。TI がこれらのリソースを提供することは、適用される TI の保証または他の保証の放棄の拡大や変更を意味するものではありません。TI がカスタム、またはカスタマー仕様として明示的に指定していない限り、TI の製品は標準的なカタログに掲載される汎用機器です。

お客様がいかなる追加条項または代替条項を提案する場合も、TI はそれらに異議を唱え、拒否します。

Copyright © 2026, Texas Instruments Incorporated

最終更新日 : 2025 年 10 月