

TLV3603-EP 拡張製品、325MHz 高速コンパレータ、伝搬遅延時間 2.5ns

1 特長

- VID:V62/24633-01XE
- 管理されたベースライン
 - 単一の製造施設
 - 単一のアセンブリ/テスト施設
 - 長期にわたる製品ライフ サイクル
- 温度範囲: -55°C ~ +125°C
- 小さい伝搬遅延: 2.5ns
- 小さいオーバードライブ分散: 700ps
- 高いトグル周波数: 325MHz
- 狭パルス幅検出性能: 1.5ns
- 両方のレールから 200mV 拡張された入力同相モード範囲
- 電源電圧範囲: 2.4V ~ 5.5V
- 可変ヒステリシス制御
- 出力ラッチ機能

2 アプリケーション

- 衛星用電源システム (EPS)
- レーダー画像処理ペイロード
- 通信ペイロード
- 飛行制御ユニット

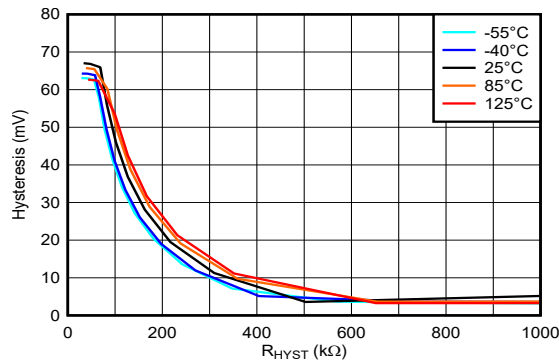

ヒステリシスと抵抗の関係、5V

3 概要

TLV3603-EP は、レール ツー レール入力、2.5ns の伝搬遅延時間、325MHz 動作の高速コンパレータです。本コンパレータは、速い応答と広い動作電圧範囲を備えており、レーダー画像処理および通信ペイロードシステムの狭信号パルス検出およびデータ / クロック リカバリ アプリケーションに最適です。

TLV3603-EP のプッシュプル (シングルエンド) 出力を使うと、他の高速差動出力コンパレータに比べて消費電力を低減できるとともに、I/O インターフェイスの基板間配線を簡素化し、コストを削減できます。さらに、TLV3603-EP は可変ヒステリシス制御や出力ラッチ機能などの機能を備えています。このコンパレータは、下流でよく使われるほとんどのデジタル コントローラおよび IO エクスパンダと直接接続できます。

TLV3603-EP は、高速相補型 BiCMOS プロセスを使用し、6 ピンの SOT-23 パッケージで供給されます。

製品情報

部品番号	パッケージ (1)	本体サイズ (公称)(2)
TLV3603-EP	SOT-23 (6)	1.25 mm × 2.00mm

- (1) 利用可能なすべてのパッケージについては、データの末尾にある追加の注文情報を参照してください
- (2) パッケージ サイズ (長さ × 幅) は公称値であり、該当する場合はピンも含まれます。

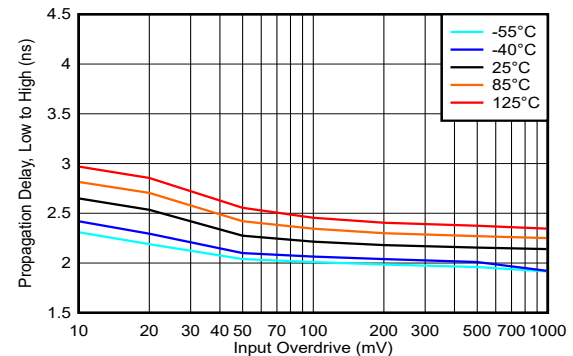

伝搬遅延 (Low から High) と入力オーバードライブ、5V



Table of Contents

1 特長	1	7 Application and Implementation	16
2 アプリケーション	1	7.1 Application Information.....	16
3 概要	1	7.2 Typical Application.....	18
4 Pin Configuration and Functions	3	8 Power Supply Recommendations	20
5 Specifications	4	9 Layout	21
5.1 Absolute Maximum Ratings.....	4	9.1 Layout Guidelines.....	21
5.2 ESD Ratings.....	4	9.2 Layout Example.....	21
5.3 Recommended Operating Conditions.....	4	10 Device and Documentation Support	22
5.4 Thermal Information.....	4	10.1 Device Support.....	22
5.5 Electrical Characteristics.....	5	10.2 ドキュメントの更新通知を受け取る方法.....	22
5.6 Timing Diagrams.....	7	10.3 サポート・リソース.....	22
5.7 Typical Characteristics.....	8	10.4 Trademarks.....	22
6 Detailed Description	14	10.5 静電気放電に関する注意事項.....	22
6.1 Overview.....	14	10.6 用語集.....	22
6.2 Functional Block Diagram.....	14	11 Revision History	22
6.3 Feature Description.....	14	12 Mechanical, Packaging, and Orderable Information	22
6.4 Device Functional Modes.....	14		

4 Pin Configuration and Functions

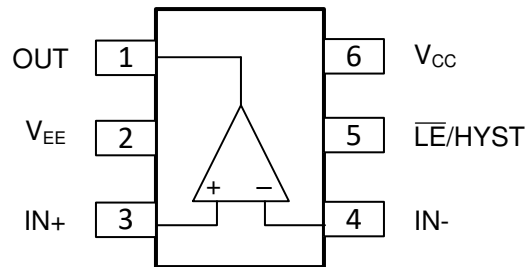

**図 4-1. DBV Package
6-Pin SOT-23
Top View**

表 4-1. Pin Functions

PIN		I/O	DESCRIPTION
NAME	TLV3603-EP		
OUT	1	O	Output (Push-Pull)
V_{EE}	2	–	Negative power supply
IN+	3	I	Non-Inverting (positive) input
IN-	4	I	Inverting (negative) input
\overline{LE}/HYS	5	I	Adjustable hysteresis control and latch
V_{CC}	6	–	Positive power supply

5 Specifications

5.1 Absolute Maximum Ratings

over operating free-air temperature range (unless otherwise noted)⁽¹⁾

	MIN	MAX	UNIT
Input Supply Voltage: $V_{CC} - V_{EE}$	-0.3	6	V
Input Voltage (IN+, IN-) ⁽²⁾	$V_{EE} - 0.3$	$V_{CC} + 0.3$	V
Differential Input Voltage ($V_{DI} = IN+ - IN-$)	$-(V_{CC} - V_{EE} + 0.3)$	$+(V_{CC} - V_{EE} + 0.3)$	V
Output Voltage (OUT) ⁽³⁾	$V_{EE} - 0.3$	$V_{CC} + 0.3$	V
Latch and Hysteresis Control (\overline{LE}/HYS)	$V_{EE} - 0.3$	$V_{CC} + 0.3$	V
Current into Input pins (IN+, IN-, \overline{LE}/HYS) ⁽²⁾		±10	mA
Current into Output pins (OUT) ⁽³⁾		±50	mA
Junction temperature, T_J		150	°C
Storage temperature, T_{stg}	-65	150	°C

- (1) Operation outside the Absolute Maximum Ratings can cause permanent device damage. Absolute Maximum Ratings do not imply functional operation of the device at these or any other conditions beyond those listed under Recommended Operating Conditions. If used outside the Recommended Operating Conditions but within the Absolute Maximum Ratings, the device may not be fully functional, and this may affect device reliability, functionality, performance, and shorten the device lifetime.
- (2) Input terminals are diode-clamped to the power-supply rails. Input signals that can swing more than 0.3V beyond the supply rails must be current-limited to 10mA or less.
- (3) Output terminals are diode-clamped to the power-supply rails. Output signals that can swing more than 0.3V beyond the supply rails must be current-limited to 50mA or less.

5.2 ESD Ratings

			VALUE	UNIT
TLV3603-EP				
$V_{(ESD)}$	Electrostatic discharge	Human-body model (HBM), per ANSI/ESDA/JEDEC JS-001 ⁽¹⁾	±2000	V
$V_{(ESD)}$	Electrostatic discharge	Charged-device model (CDM), per ANSI/ESDA/JEDEC JS-002 ⁽²⁾	±1000	V

- (1) JEDEC document JEP155 states that 500V HBM allows safe manufacturing with a standard ESD control process.
- (2) JEDEC document JEP157 states that 250V CDM allows safe manufacturing with a standard ESD control process.

5.3 Recommended Operating Conditions

over operating free-air temperature range (unless otherwise noted)

	MIN	MAX	UNIT
Input Supply Voltage: $V_{CC} - V_{EE}$	2.4	5.5	V
Input Voltage Range (IN+, IN-)	$V_{EE} - 0.3$	$V_{CC} + 0.3$	V
Latch and Hysteresis Control (\overline{LE}/HYS)	$V_{EE} - 0.3$	$V_{CC} + 0.3$	V
Ambient temperature, T_A	-55	125	°C

5.4 Thermal Information

THERMAL METRIC ⁽¹⁾		TLV3603-EP	UNIT
		DBV (SOT-23)	
		6 PINS	
$R_{\theta JA}$	Junction-to-ambient thermal resistance	191.1	°C/W
$R_{\theta JC(top)}$	Junction-to-case (top) thermal resistance	117.1	°C/W
$R_{\theta JC(bottom)}$	Junction-to-case (bottom) thermal resistance	79.1	°C/W
$R_{\theta JB}$	Junction-to-board thermal resistance	56.7	°C/W
ψ_{JT}	Junction-to-top characterization parameter	78.8	°C/W

- (1) For more information about traditional and new thermal metrics, see the [Semiconductor and IC Package Thermal Metrics](#) report.

5.5 Electrical Characteristics

$V_{CC} = 2.5, 3.3$ and $5V$, $V_{EE} = 0V$, $V_{CM} = V_{EE} + 300mV$, $C_L = 5pF$ probe capacitance, typical at $T_A = 25^\circ C$ (unless otherwise noted).

PARAMETER		TEST CONDITIONS	MIN	TYP	MAX	UNIT
DC Input Characteristics						
V_{IO}	Input offset voltage	$T_A = -55^\circ C$ to $+125^\circ C$	-7	± 0.5	7	mV
dV_{IO}/dT	Input offset voltage drift			± 3.0		$\mu V/^\circ C$
V_{CM}	Input common mode voltage range	$T_A = -55^\circ C$ to $+125^\circ C$	$V_{EE} - 0.2$		$V_{CC} + 0.2$	V
C_{IN}	Input capacitance			1		pF
R_{DM}	Input differential mode resistance			67		k Ω
R_{CM}	Input common mode resistance			5		M Ω
I_B	Input bias current	$T_A = -55^\circ C$ to $+125^\circ C$		1	5	μA
I_{OS}	Input offset current			± 0.03		μA
CMRR	Common-mode rejection ratio	$V_{CM} = V_{EE} - 0.2V$ to $V_{CC} + 0.2V$		80		dB
PSRR	Power-supply rejection ratio	$V_{CC} = 2.4$ to $5.5V$		80		dB
DC Output Characteristics						
V_{OH}	Output high voltage from V_{CC}	$I_{SOURCE} = 1mA$ $T_A = -55^\circ C$ to $+125^\circ C$		60	80	mV
V_{OL}	Output low voltage from V_{EE}	$I_{SINK} = 1mA$ $T_A = -55^\circ C$ to $+125^\circ C$		60	80	mV
I_{SC_SOURCE}	Output Short-Circuit Current - Source	$T_A = -55^\circ C$ to $+125^\circ C$	10	30		mA
I_{SC_SINK}	Output Short-Circuit Current - Sink	$T_A = -55^\circ C$ to $+125^\circ C$	10	30		mA
Power Supply						
I_{CC}	quiescent current	Output being high $T_A = -55^\circ C$ to $+125^\circ C$		5.7	7.8	mA
$V_{POR (positive)}$	Power-On Reset Voltage			2.1		V
AC Characteristics						
t_{PD}	Propagation delay	$V_{OVERDRIVE} = V_{UNDERDRIVE} = 50mV$ $T_A = -55^\circ C$ to $+125^\circ C$		2.5	4.5 ⁽¹⁾	ns
$t_{CM_DISPERSION}$	Common dispersion	V_{CM} varied from V_{EE} to V_{CC}		80		ps
$t_{OD_DISPERSION}$	Overdrive dispersion	Overdrive varied from 10mV to 125mV		700		ps
$t_{UD_DISPERSION}$	Underdrive dispersion	Underdrive varied from 10mV to 125mV		330		ps
t_R	Rise time	10% to 90%		0.75		ns
t_F	Fall time	90% to 10%		0.75		ns
t_{JITTER}	RMS Jitter	$V_{IN} = 100mV_{P-P}$, $f_{IN} = 100MHz$, Jitter BW = 10Hz – 50MHz		4		ps
f_{TOGGLE}	Input toggle frequency	$V_{IN} = 200mV_{PP}$ Sine Wave, When output high reaches 90% of $V_{CC} - V_{EE}$ or output low reaches 10% of $V_{CC} - V_{EE}$		325		MHz
PulseWidth	Minimum allowed input pulse width	$V_{OVERDRIVE} = V_{UNDERDRIVE} = 50mV$ $PW_{OUT} = 90\%$ of PW_{IN}		1.5		ns

5.5 Electrical Characteristics (続き)

$V_{CC} = 2.5, 3.3$ and $5V$, $V_{EE} = 0V$, $V_{CM} = V_{EE} + 300mV$, $C_L = 5pF$ probe capacitance, typical at $T_A = 25^\circ C$ (unless otherwise noted).

PARAMETER		TEST CONDITIONS	MIN	TYP	MAX	UNIT
Latching/Adjustable Hysteresis						
V_{HYST}	Input hysteresis voltage	$V_{HYST} = \text{Logic High}$		0		mV
V_{HYST}	Input hysteresis voltage	$R_{HYST} = \text{Floating}$		3		mV
V_{HYST}	Input hysteresis voltage	$R_{HYST} = 150k\Omega$		30		mV
V_{HYST}	Input hysteresis voltage	$R_{HYST} = 56k\Omega$		60		mV
V_{IH_LE}	\overline{LE} pin input high level	$T_A = -55^\circ C$ to $+125^\circ C$	$V_{EE} + 1.5$			V
V_{IL_LE}	\overline{LE} pin input low level	$T_A = -55^\circ C$ to $+125^\circ C$		$V_{EE} + 0.35$		V
I_{IH_LE}	\overline{LE} pin input leakage current	$V_{LE} = V_{CC}$ $T_A = -55^\circ C$ to $+125^\circ C$			15	μA
I_{IL_LE}	\overline{LE} pin input leakage current	$V_{LE} = V_{EE}$ $T_A = -55^\circ C$ to $+125^\circ C$			40	μA
t_{SETUP}	Latch setup time			-1.4		ns
t_{HOLD}	Latch hold time			7.2		ns
t_{PL}	Latch to OUT delay			7		ns

(1) Assured by characterization

5.6 Timing Diagrams



図 5-1. General Timing Diagram



図 5-2. Overdrive Dispersion

5.7 Typical Characteristics

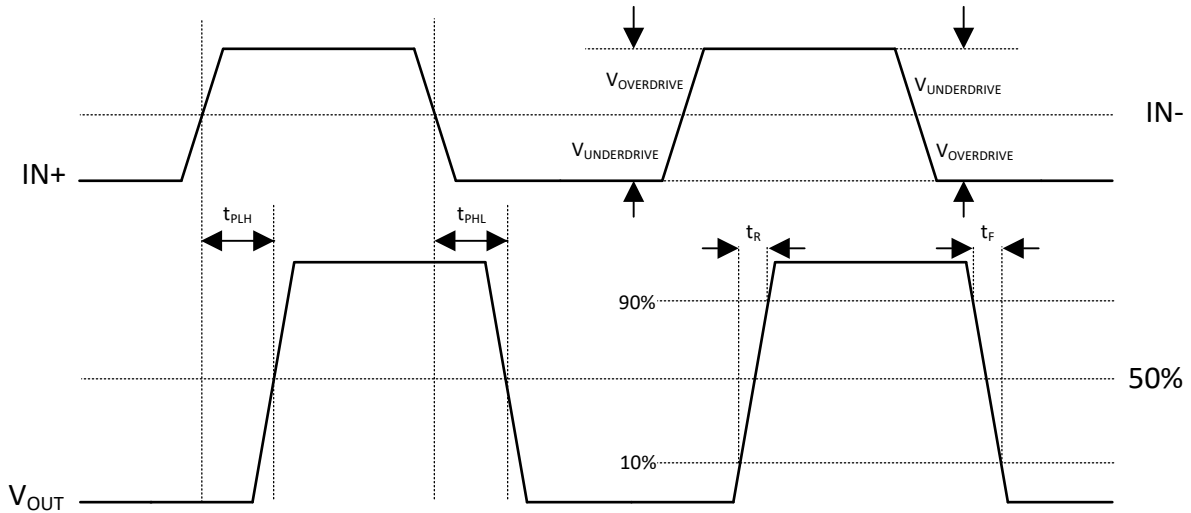
At $T_A = 25^\circ\text{C}$, $V_{CC} - V_{EE} = 2.5\text{V to }5\text{V}$, $V_{CM} = 300\text{mV}$, $R_{HYST} = 150\text{k}\Omega$, and input overdrive = 50mV, unless otherwise noted.

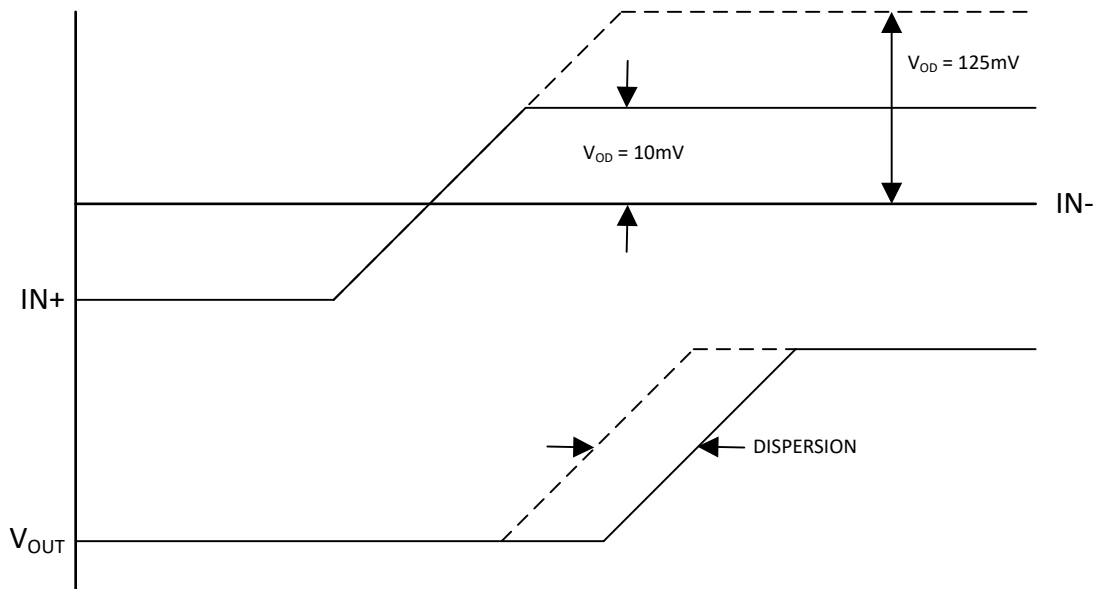

图 5-3. Offset vs. Temperature



图 5-4. Hysteresis vs. Temperature

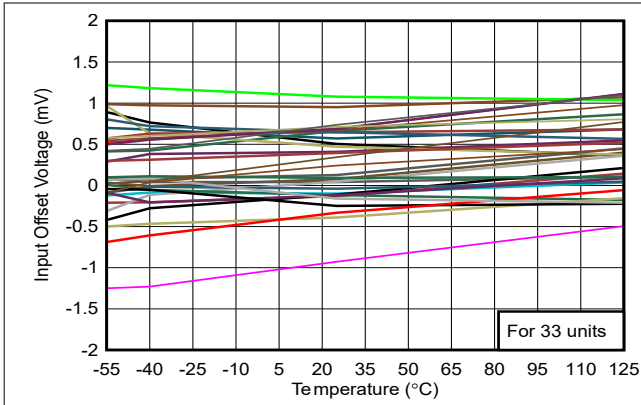

图 5-5. Offset vs. Common-Mode, 2.5V

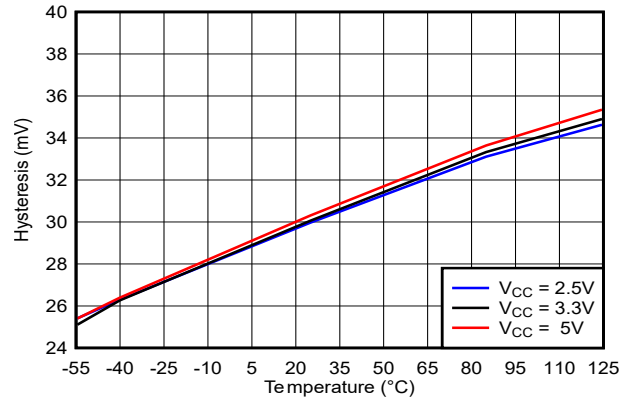

图 5-6. Hysteresis vs. Common-Mode, 2.5V

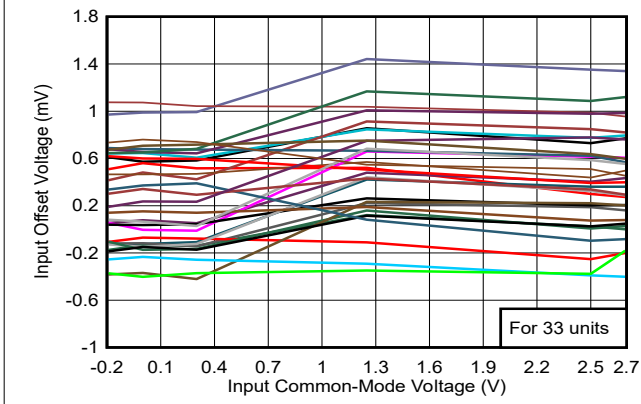

图 5-7. Offset vs. Common-Mode, 3.3V

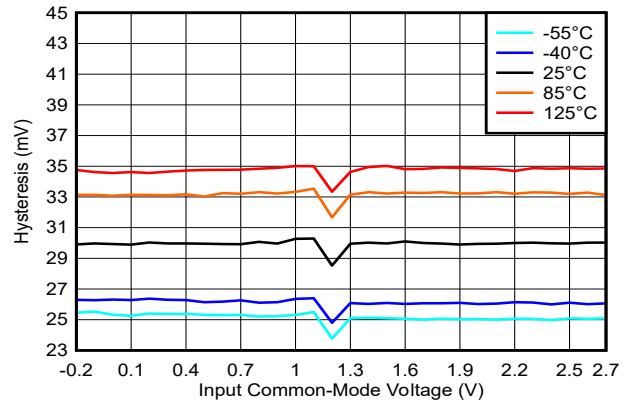

图 5-8. Hysteresis vs. Common-Mode, 3.3V

5.7 Typical Characteristics (continued)

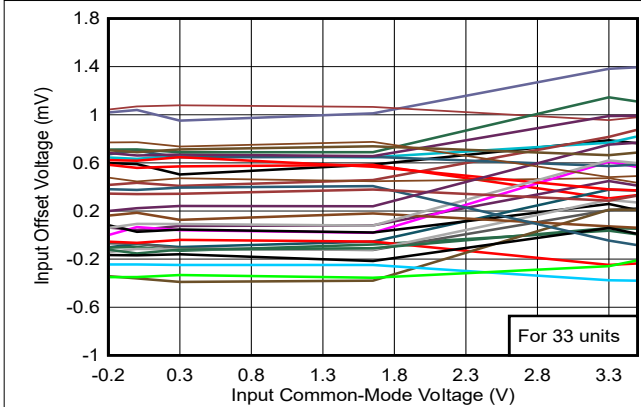
At $T_A = 25^\circ\text{C}$, $V_{CC} - V_{EE} = 2.5\text{V to } 5\text{V}$, $V_{CM} = 300\text{mV}$, $R_{HYST} = 150\text{k}\Omega$, and input overdrive = 50mV, unless otherwise noted.

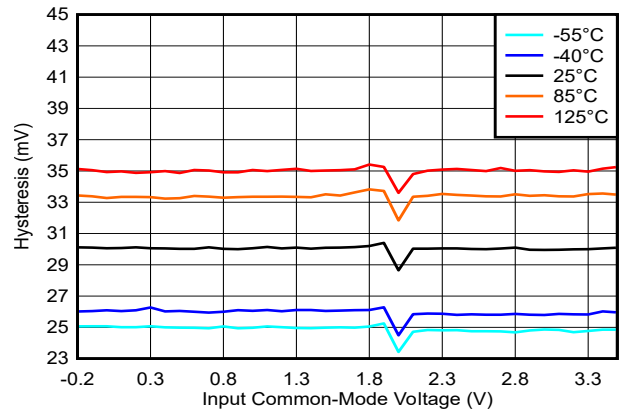
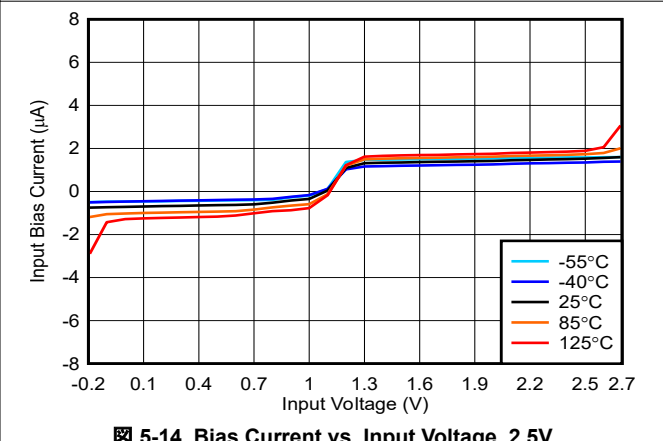
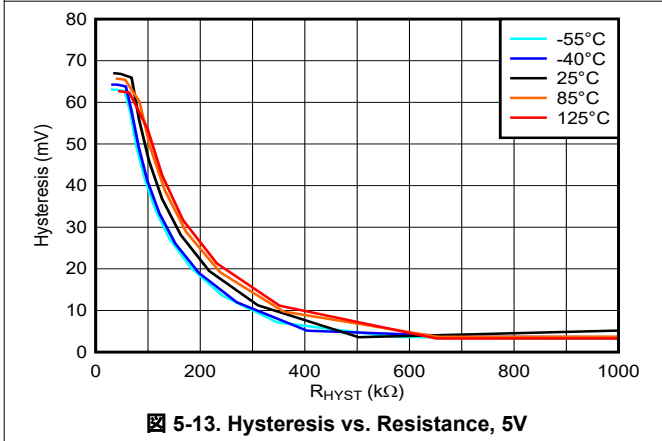
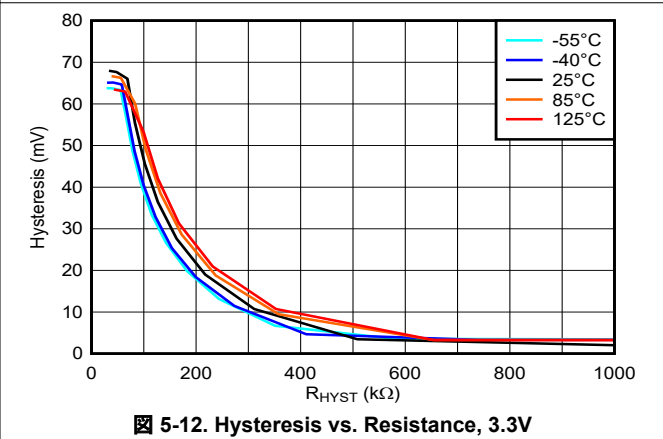
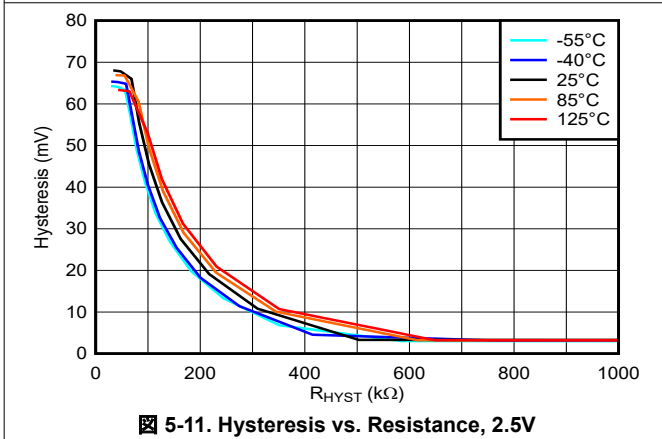
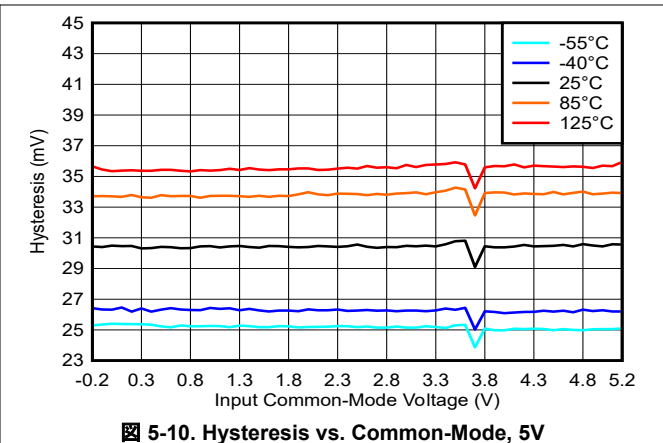
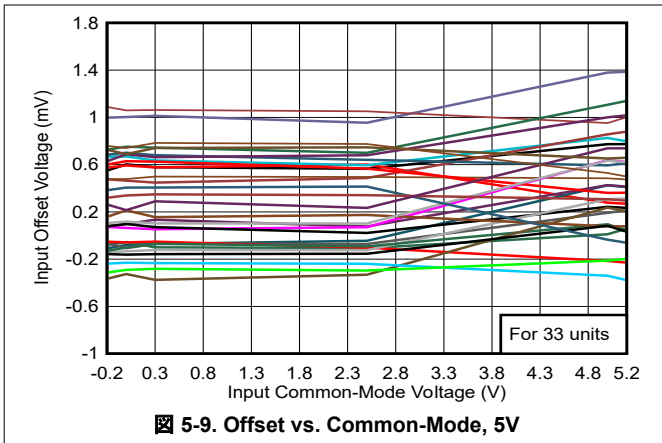

5.7 Typical Characteristics (continued)

At $T_A = 25^\circ\text{C}$, $V_{CC} - V_{EE} = 2.5\text{V to } 5\text{V}$, $V_{CM} = 300\text{mV}$, $R_{HYST} = 150\text{k}\Omega$, and input overdrive = 50mV, unless otherwise noted.

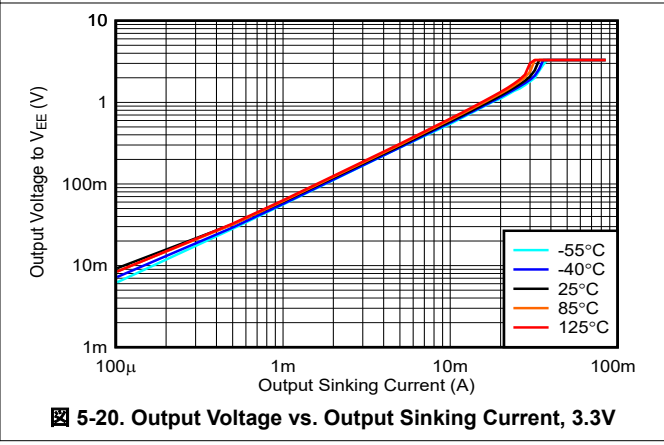
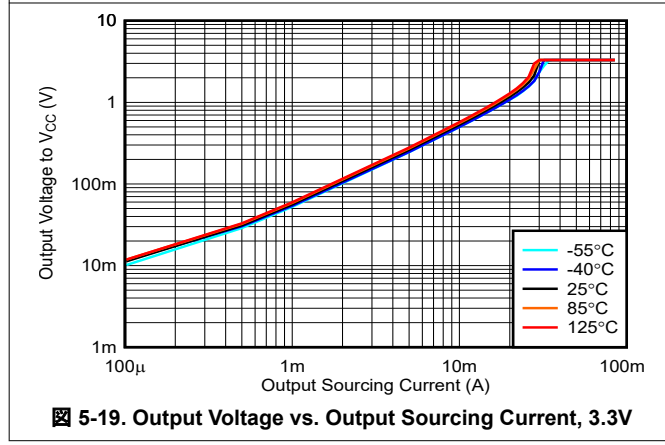
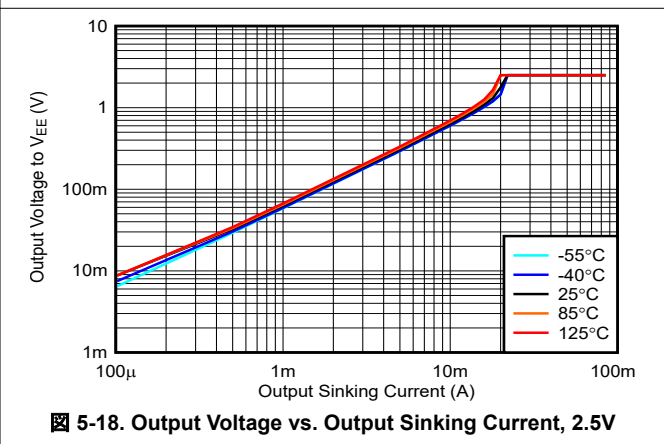
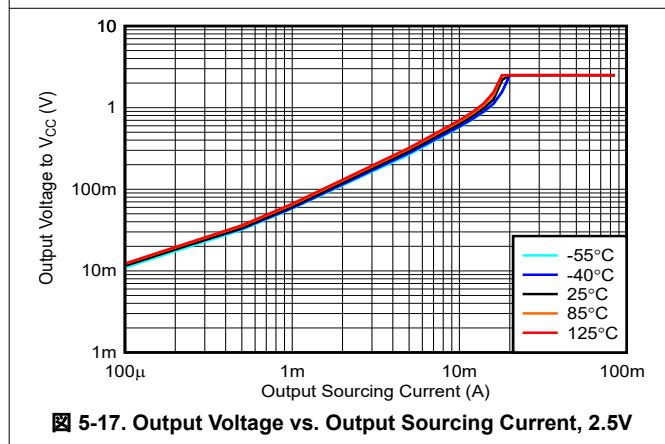
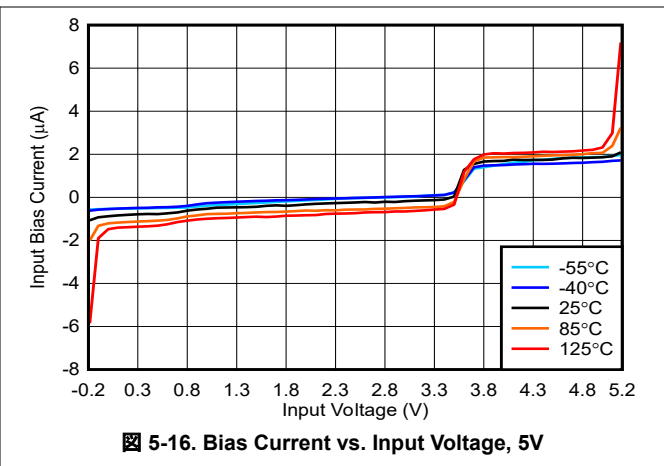
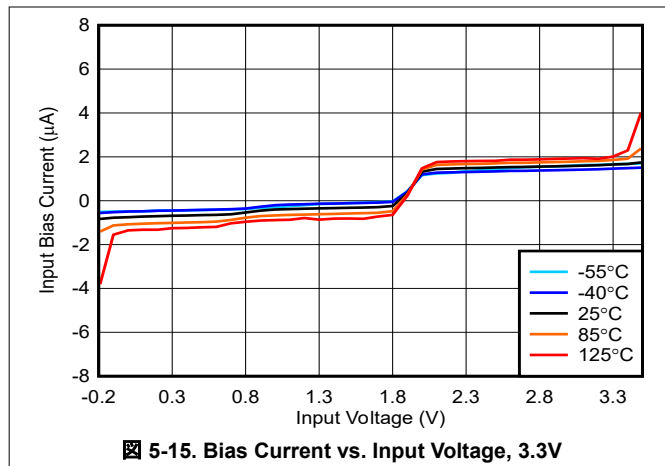

5.7 Typical Characteristics (continued)

At $T_A = 25^\circ\text{C}$, $V_{CC} - V_{EE} = 2.5\text{V to }5\text{V}$, $V_{CM} = 300\text{mV}$, $R_{HYST} = 150\text{k}\Omega$, and input overdrive = 50mV, unless otherwise noted.

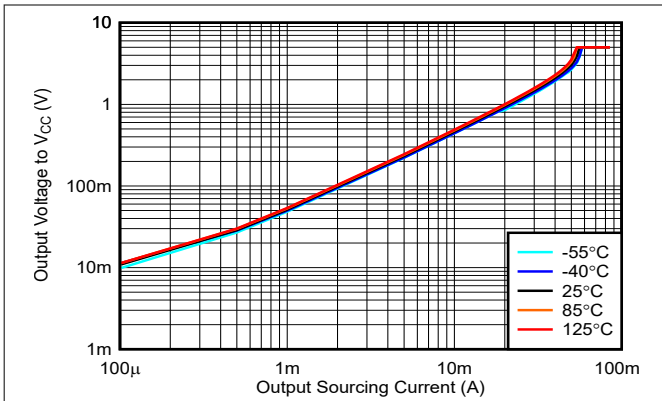

5-21. Output Voltage vs. Output Sourcing Current, 5V

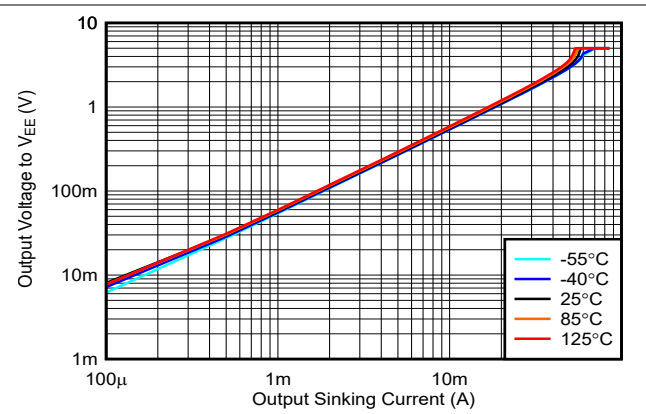

5-22. Output Voltage vs. Output Sinking Current, 5V

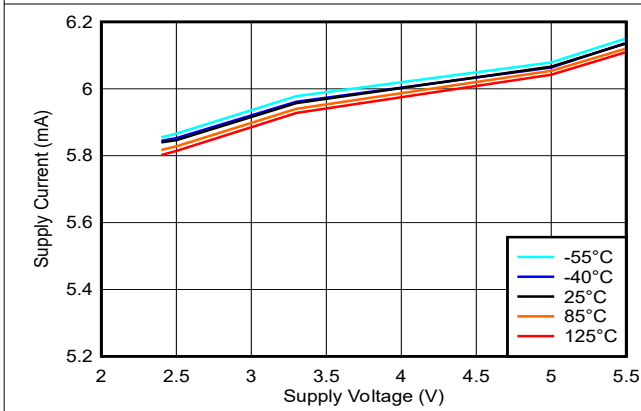

5-23. Supply Current vs. Voltage (Output Low)

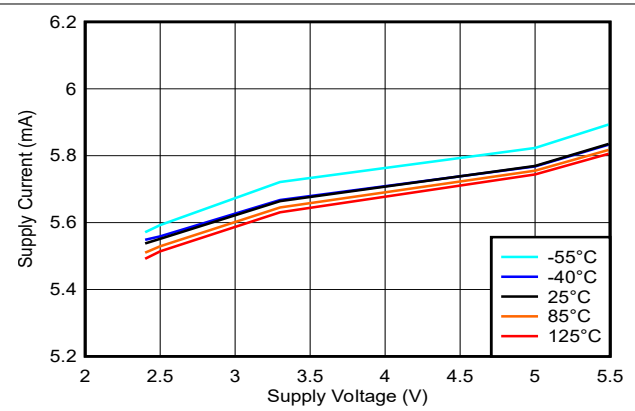

5-24. Supply Current vs. Voltage (Output High)

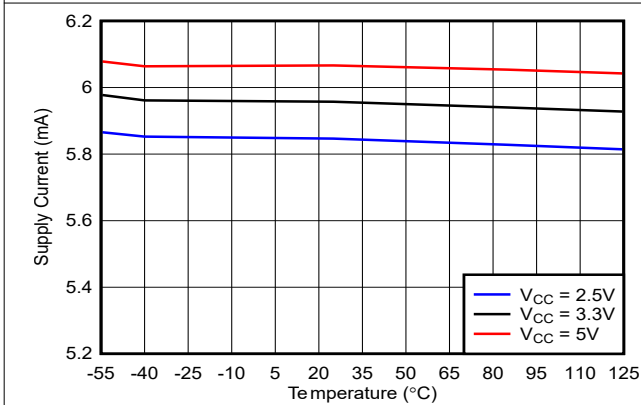

5-25. Supply Current vs. Temp (Output Low)

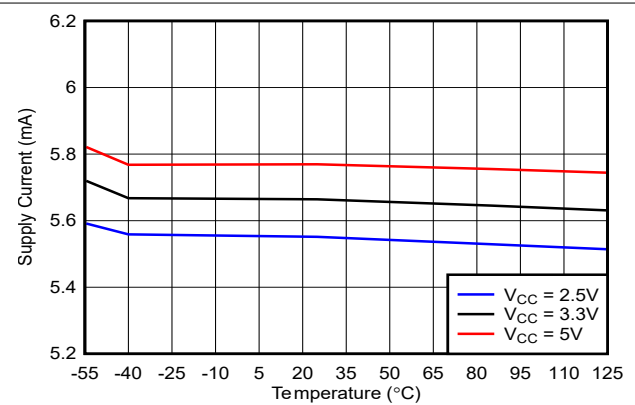

5-26. Supply Current vs. Temp (Output High)

5.7 Typical Characteristics (continued)

At $T_A = 25^\circ\text{C}$, $V_{CC} - V_{EE} = 2.5\text{V to }5\text{V}$, $V_{CM} = 300\text{mV}$, $R_{HYST} = 150\text{k}\Omega$, and input overdrive = 50mV, unless otherwise noted.

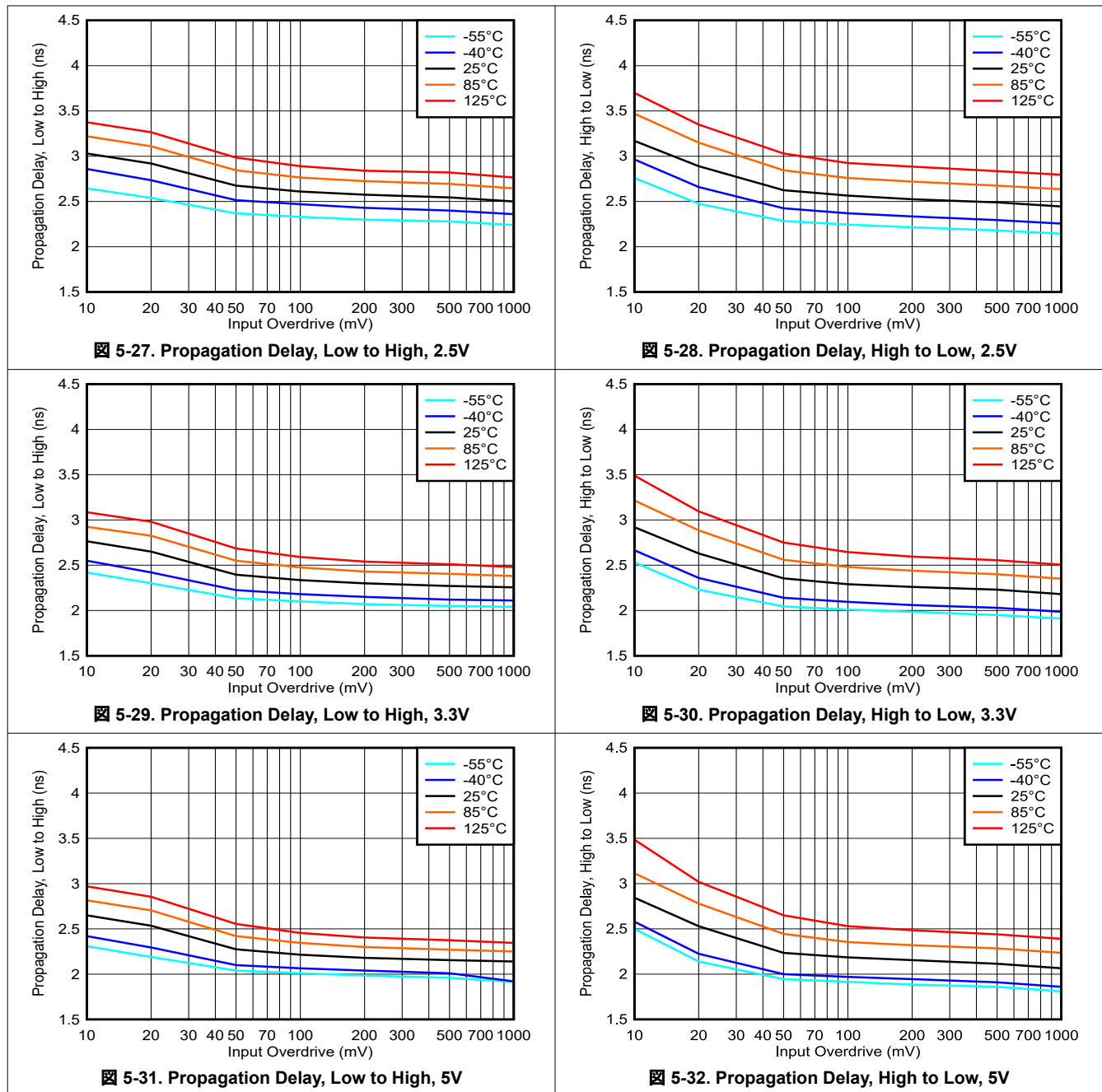

5.7 Typical Characteristics (continued)

At $T_A = 25^\circ\text{C}$, $V_{CC} - V_{EE} = 2.5\text{V}$ to 5V , $V_{CM} = 300\text{mV}$, $R_{HYST} = 150\text{k}\Omega$, and input overdrive = 50mV , unless otherwise noted.

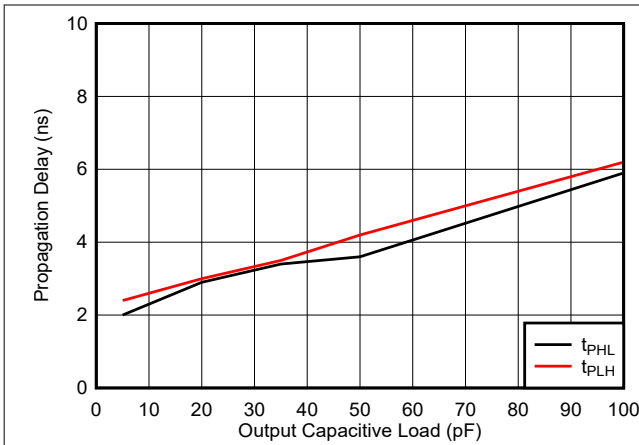

5-33. Propagation Delay vs. Load Capacitance, 3.3V

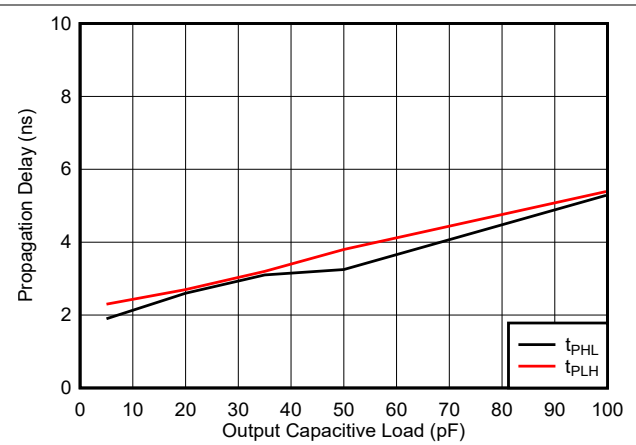

5-34. Propagation Delay vs. Load Capacitance, 5V

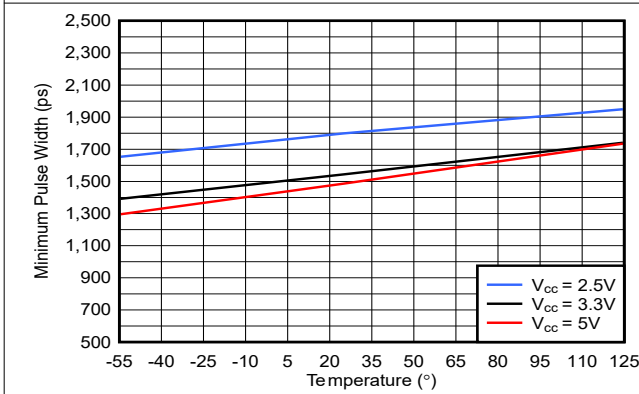

5-35. Minimum Pulse Width vs. Temperature

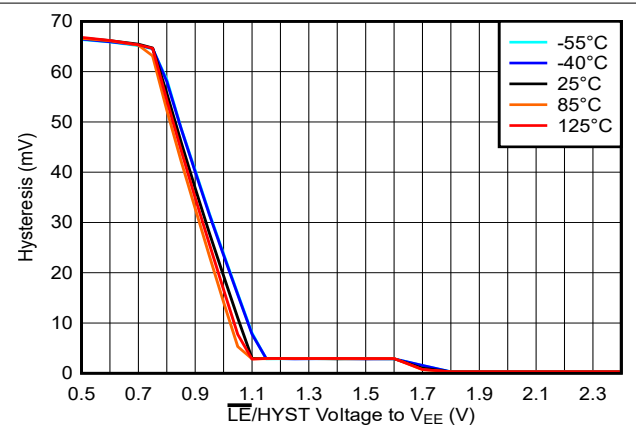

5-36. Hysteresis Voltage vs. $\overline{LE}/HYST$ Voltage, 2.5V

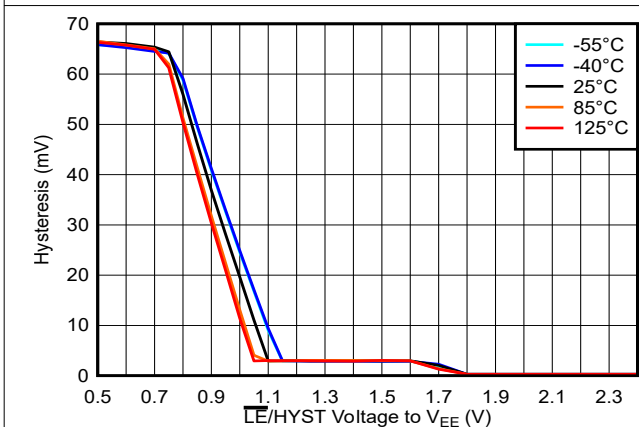

5-37. Hysteresis Voltage vs. $\overline{LE}/HYST$ Voltage, 3.3V

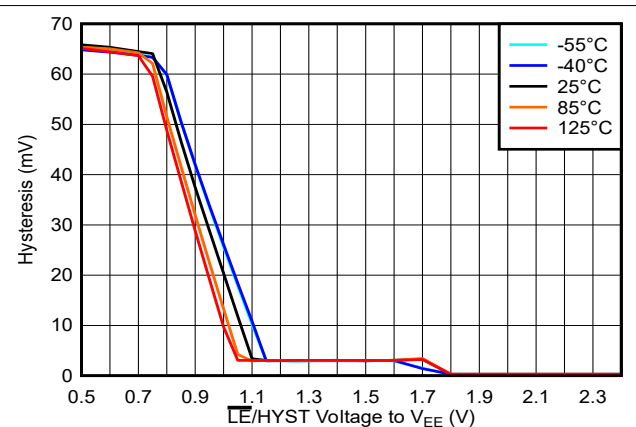

5-38. Hysteresis Voltage vs. $\overline{LE}/HYST$ Voltage, 5V

6 Detailed Description

6.1 Overview

The TLV3603-EP is a high-speed comparator with a single-ended (push-pull) output stage. The fast response time is well suited for applications that require narrow pulse width detection or high toggle frequencies. The TLV3603-EP is available in a 6-pin SOT23 package.

6.2 Functional Block Diagram

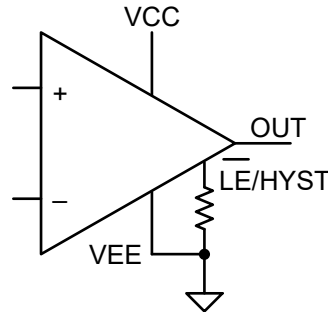

6.3 Feature Description

The TLV3603-EP is a single channel, high speed comparator with a typical propagation delay of 2.5ns and a push-pull output. The minimum pulse width detection capability is 1.5ns and the typical toggle rate is 325MHz. This comparator is well-suited for distance measurement applications that utilize a time-of-flight architecture as well as systems that suffer from capacitive loading and require data and clock recovery. In addition to high speed, the TLV3603-EP offers a rail-to-rail input stage capable of operating up to 300mV beyond each power supply rail combined with a maximum 7mV input offset. The TLV3603-EP also provides adjustable hysteresis via an external resistor for noise suppression or a latching mode to hold the output of the comparator output.

6.4 Device Functional Modes

The TLV3603-EP has two modes of operation. The first is an active mode where the output reflects the condition at the inputs when an external resistor is connected to ground on the $\overline{\text{LE}}/\text{HYS}$ pin. The resistor value creates a specified amount of internal hysteresis for the comparator without requiring external, positive feedback. The second is a latch mode where the output is held at the last active state when the $\overline{\text{LE}}/\text{HYS}$ pin is pulled low. The TLV3603-EP returns to active mode after a short delay when the pin is pulled high.

6.4.1 Inputs

The TLV3603-EP features an input stage capable of operating 300mV below negative power supply (ground) and 300mV beyond the positive supply voltage, allowing for zero cross detection and maximizing input dynamic range given a certain power supply. The input stages are protected from conditions where the voltage on either pin exceeds this level by internal ESD protection diodes to VCC and VEE. An external resistor must be used to limit the current to less than 10mA to avoid damaging the inputs when exceeding the recommended input voltage range.

6.4.2 Push-Pull (Single-Ended) Output

The TLV3603-EP output has excellent drive capability and is designed to connect directly to CMOS logic input devices. Likewise, the comparator output stage is capable of driving capacitive loads. Transient performance parameters in the Electrical Characteristics Tables and Typical Characteristics section are for a load of 5pF, corresponding to a standard CMOS load. Device performance for larger capacitive loads can be found in the typical performance curves titled Propagation Delay vs Load Capacitance. For maximum speed and performance, output load capacitance must be minimized.

6.4.3 Known Startup Condition

The TLV3603-EP has a Power-on-Reset (POR) circuit which provides system designers a known start-up condition for the output of the comparators. When the power supply (V_{CC}) is ramping up or ramping down, the POR circuit is active when V_{CC} is below V_{POR} . When active, the POR circuit holds the output low at V_{EE} . When V_{CC} is greater than or equal to V_{POR} as stated in [Electrical Characteristics](#), the comparator output reflects the state of the input pins.

6-1 shows how the TLV3603-EP output responds for V_{CC} rising. The input is configured with a logic high input to highlight the transition from the POR circuit control (logic low output) to a standard comparator operation where the output reflects the input condition. Note how the output goes high when V_{CC} reaches 2.1V.

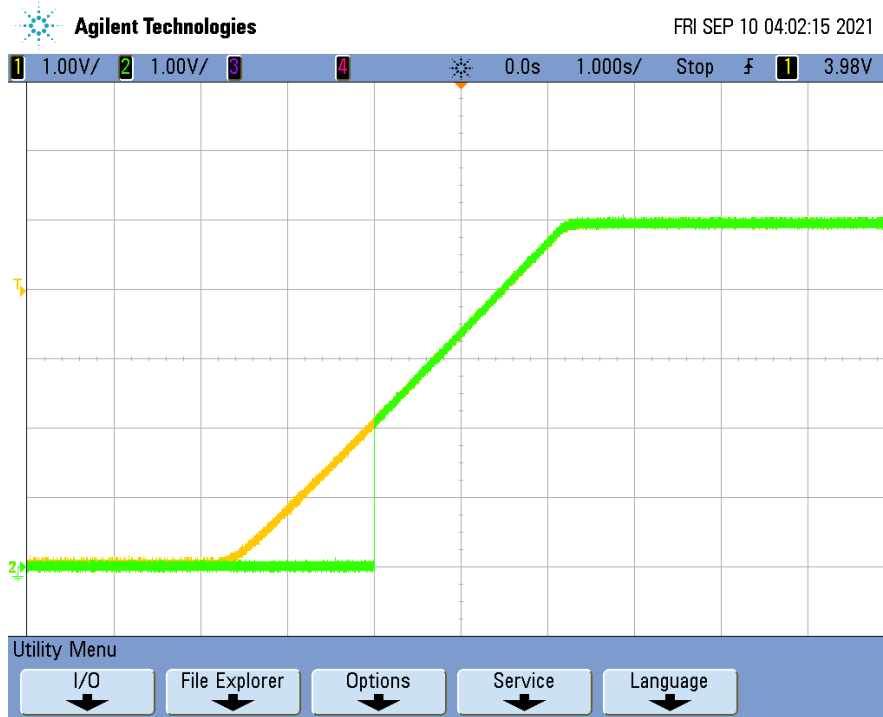

6-1. Output for V_{CC} Rising

7 Application and Implementation

注

Information in the following applications sections is not part of the TI component specification, and TI does not warrant its accuracy or completeness. TI's customers are responsible for determining suitability of components for their purposes, as well as validating and testing their design implementation to confirm system functionality.

7.1 Application Information

7.1.1 Adjustable Hysteresis

As a result of a comparator's high open loop gain, there is a small band of input differential voltage where the output can toggle back and forth between "logic high" and "logic low" states ("Chatter"). This can cause design challenges for inputs with slow rise and fall times or systems with excessive noise. These challenges can be overcome by adding hysteresis to the comparator.

The TLV3603-EP has a $\overline{\text{LE}}/\text{HYS}$ pin that can be used to increase the internal hysteresis of the comparator. To change the internal hysteresis of the comparator, connect a single resistor as shown in the adjusting hysteresis figure between the $\overline{\text{LE}}/\text{HYS}$ pin and VEE. A curve of [hysteresis versus resistance](#) is provided below to provide guidance in setting the desired amount of hysteresis.



図 7-1. Adjustable Hysteresis using External Resistor



図 7-2. Adjustable Hysteresis using External Voltage

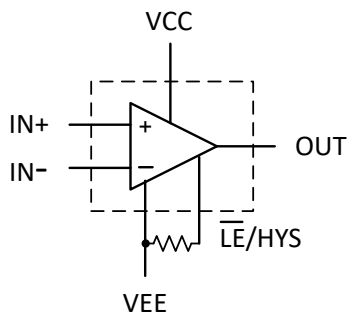

図 7-3. Hysteresis vs. R_{HYS} at $V_{\text{CC}} = 5\text{V}$

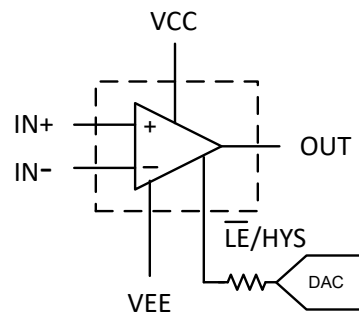

図 7-4. Hysteresis vs. V_{HYS} at $V_{\text{CC}} = 5\text{V}$

To provide dynamic hysteresis, an external 0.7V to 1.2V voltage, such as from a DAC, can be forced into the $\overline{\text{LE}}/\text{HYS}$ pin, as shown in 図 7-2 and 図 7-4. The $\overline{\text{LE}}/\text{HYS}$ pin can be internally modeled as a 40k resistor in series with a 1.25V source to VEE, so any driving circuitry must be able to sink up to 32uA. Note that the output goes into latch when $\overline{\text{LE}}/\text{HYS}$ is $\leq 400\text{mV}$, or go into shutdown when $\geq 1.25\text{V}$.

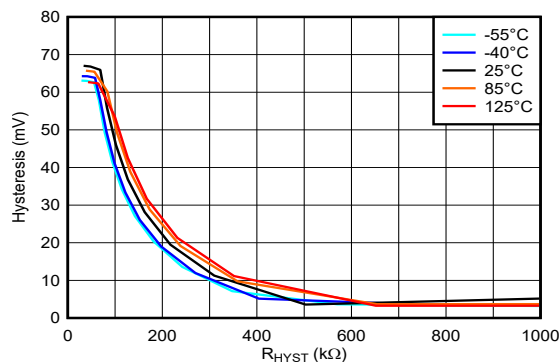
7.1.2 Capacitive Loads

For capacitive loads under 100pF, the propagation delay has minimum change (see [Propagation Delay vs. Capacitive Load](#)). However, excessive capacitive loading under high switching frequencies can increase supply current, propagation delay, or induce decreased slew rate.

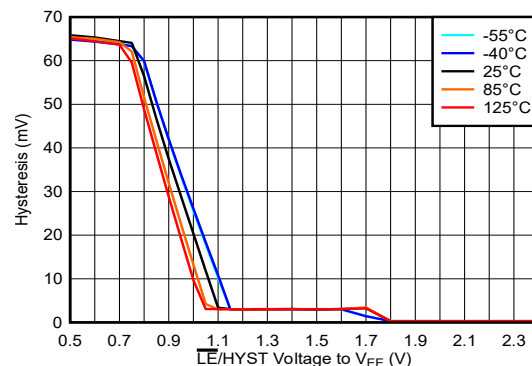
7.1.3 Latch Functionality

The latch pin for the TLV3603-EP holds the output state of the device when the voltage at the $\overline{\text{LE}}/\text{HYS}$ pin is a logic low. This is particularly useful when the output state is intended to remain unchanged. An important consideration of the latch functionality is the latch hold and setup times. Latch hold time is the minimum time required (after the latch pin is asserted) for properly latching the comparator output. Likewise, latch setup time is defined as the time that the input must be stable before the latch pin is asserted low. The figure below illustrates when the input can transition for a valid latch. Note that the typical setup time in the EC table is negative; this is due to the internal trace delays of the $\overline{\text{LE}}/\text{HYS}$ pin relative to the input pin trace delays. A small delay (t_{PL}) in the output response is shown below when the TLV3603-EP exits a latched output stage.

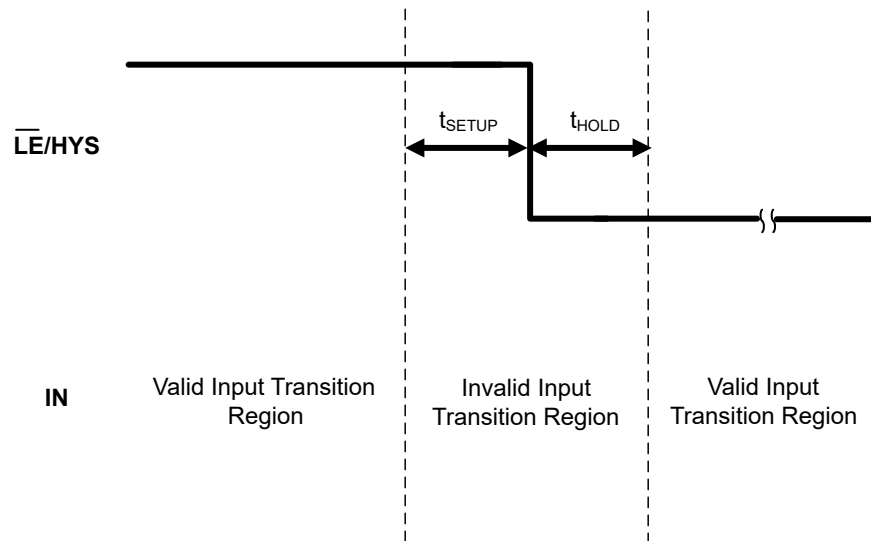

☒ 7-5. Input Change Properly Latched

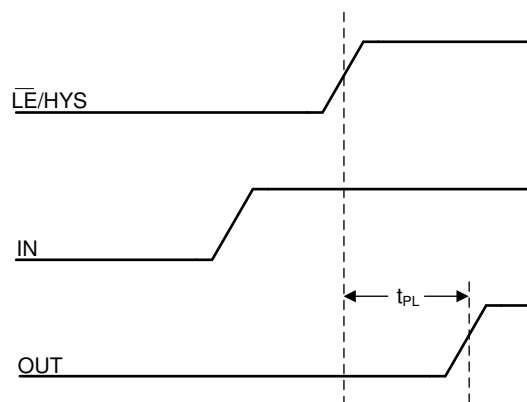

☒ 7-6. Latch Disable with Input Change

7.2 Typical Application

7.2.1 Implementing Adjustable Hysteresis

A comparator can produce “chatter” (multiple transitions) at the output when there are noise or signal variations around the reference threshold; this causes the output to change states in rapid random successions as the comparator input goes above and below the threshold of the reference. This usually occurs when the input signal is moving very slowly across the switching threshold of the comparator. This problem can be prevented by using the internal hysteresis feature of the TLV3603-EP.

The TLV3603-EP has a $\overline{\text{LE}}/\text{HYS}$ pin that allows for variable internal hysteresis depending on the resistor value connected between the pin and VEE, where increasing the resistance decreases the hysteresis to a minimum level.

7.2.1.1 Design Requirements

For this design, follow these design requirements.

表 7-1. Design Parameters

PARAMETER	VALUE
Supply Voltage (V_{CC})	5V
V_{REF}	2.5V
V_{HYS}	30mV
Lower Threshold (V_L)	2.485V
Upper Threshold (V_H)	2.515V

7.2.1.2 Detailed Design Procedure

The hysteresis vs. resistance curve (Figure 8-2) is used as guidance to set the desired amount of hysteresis.



図 7-7. V_{HYST} vs. R_{HYST} at 5V curve



図 7-8. Setting the Hysteresis using a Resistor using the TLV3603-EP

Figure 8-2 shows that for a 30mV hysteresis, a 150kΩ resistor must be placed from the $\overline{\text{LE}}/\text{HYS}$ pin to VEE, as shown in 図 7-8.

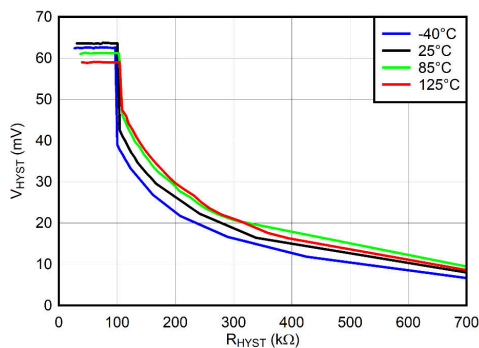
Also possible is to use an external voltage to dynamically program the V_{HYST} . Please see the [Adjustable Hysteresis](#) section for more details.

7.2.1.3 Application Curve

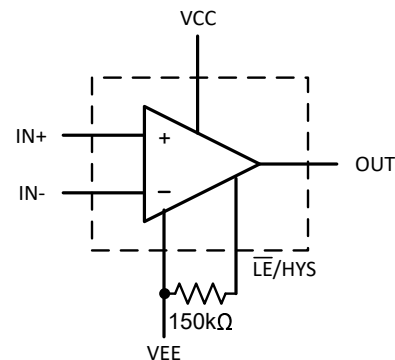

図 7-9. Hysteresis Transfer Curve using TLV3603-EP

7.2.2 Optical Receiver

The TLV3603-EP can be used in conjunction with a high speed amplifier such as the OPA830-EP to create an optical receiver as shown in the figure below. The photodiode is connected to a bias voltage and is being driven with a pulsed laser. The OPA830-EP takes the current conducting through the diode and translates the voltage for the high speed comparator to detect. The comparator then outputs the proper output level according to the threshold set (V_{REF}).

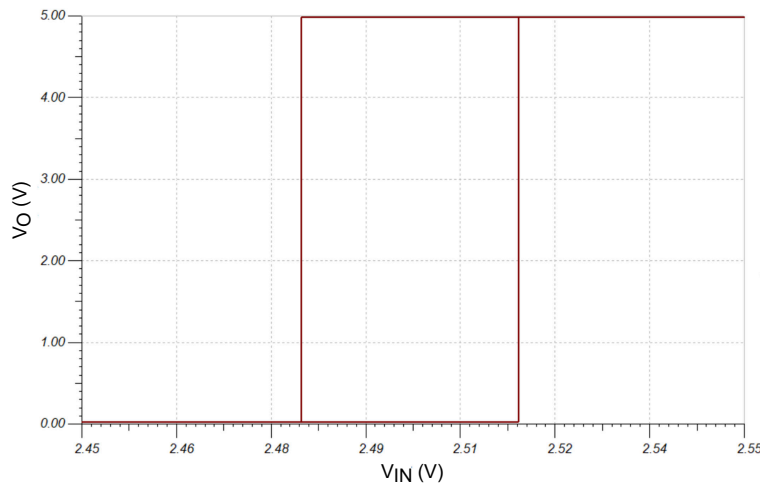

図 7-10. Optical Receiver

7.2.3 Over-Current Latch Condition

When the design is required to detect a brief over-current condition, the latching feature of the TLV3603-EP can be utilized. By latching the comparator output, the MCU does not miss the over-current occurrence. The circuit below shows one way to implement the latching function.

When an over-current condition is detected by the TLV3603-EP, the output transitions high. The occurrence of the output going high coupled with a logic high from the RESET signal from the MCU creates a logic low signal at the output of the 2-channel NAND gate. This causes the output of the TLV3603-EP to be held in a logic high state (latched), thus allowing the MCU to detect the fault condition regardless of how narrow the over-current condition persists. The addition of the NAND gate also provides a means of clearing the latch state of the

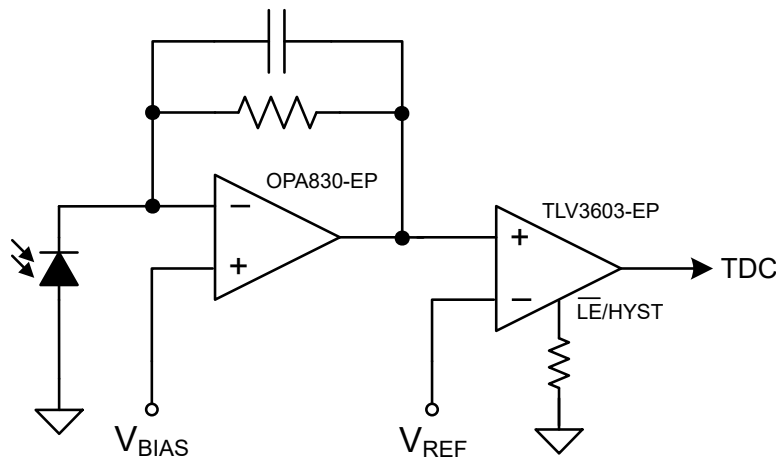
comparator once the MCU is done processing the event. This is accomplished by the MCU passing a logic low state to the $\overline{\text{LE}}/\text{HYS}$ input causing the $\overline{\text{LE}}/\text{HYS}$ pin of the comparator to be returned to a logic high state. The latched status is cleared and the TLV3603-EP output can continue to track the status of the input pins.



图 7-11. Over-Current Latched Output Circuit

8 Power Supply Recommendations

The TLV3603-EP is designed for operation from 2.4V to 5.5V. While most applications require single supply operation where VEE is connected to the ground and VCC is connected to the intended power supply level, the comparators can also be operated with split supplies. One caution when using split supplies is that the output logic levels are determined by the VCC and VEE levels. For example, if split supplies of +/- 2.5V are used, the output levels are 2.5V and -2.5V accordingly. In addition, the logic level of the $\overline{\text{LE}}/\text{HYS}$ pin is also referenced to VEE. This means that the external hysteresis resistor or voltage source on the TLV3603-EP needs to be connected between the $\overline{\text{LE}}/\text{HYS}$ pin and VEE (not to ground) for proper operation.

Regardless of single supply or split supply operation, proper decoupling capacitors are required. TI recommends using a scheme of multiple, low-ESR ceramic capacitors from the supply pins to the ground plane for optimum performance. A good combination is 100pF, 10nF, and 1uF with the lowest value capacitors closest to the comparator.

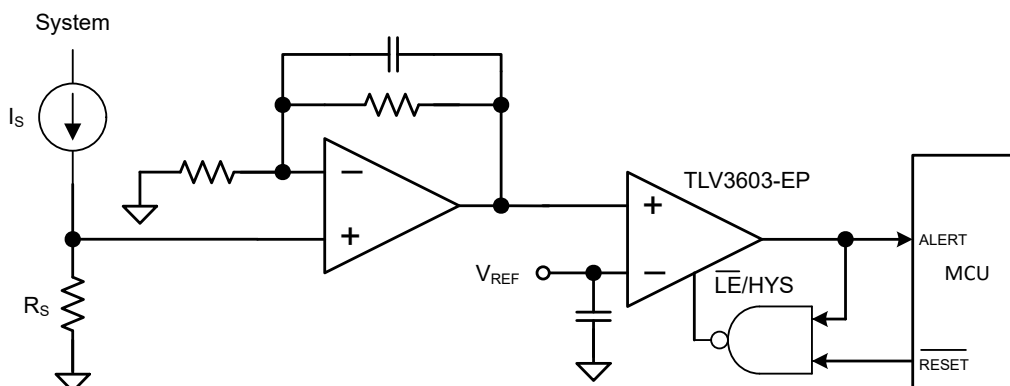
9 Layout

9.1 Layout Guidelines

Comparators are very sensitive to input noise. For best results, adhere to the following layout guidelines.

1. Use a printed-circuit-board (PCB) with a good, unbroken, low-inductance ground plane. Proper grounding (use of a ground plane) helps maintain specified device performance.

Likewise, high performance board materials such as Rogers or high speed FR4 is also recommended.

2. Place a decoupling capacitor (100pF ceramic, surface-mount capacitor) between V_{CC} and V_{EE} as close to the device as possible. Using multiple bypass capacitors in different decade ranges such as 100pF, 100nF, and 1μF provides the best noise reduction across frequency ranges.
3. On the inputs and the output, keep lead lengths as short and minimize capacitive coupling to the traces by having a keepout area around the traces that is 3x the width of the traces. Also recommended is to keep input traces away from the output traces.
4. Solder the device directly to the PCB rather than using a socket.

9.2 Layout Example

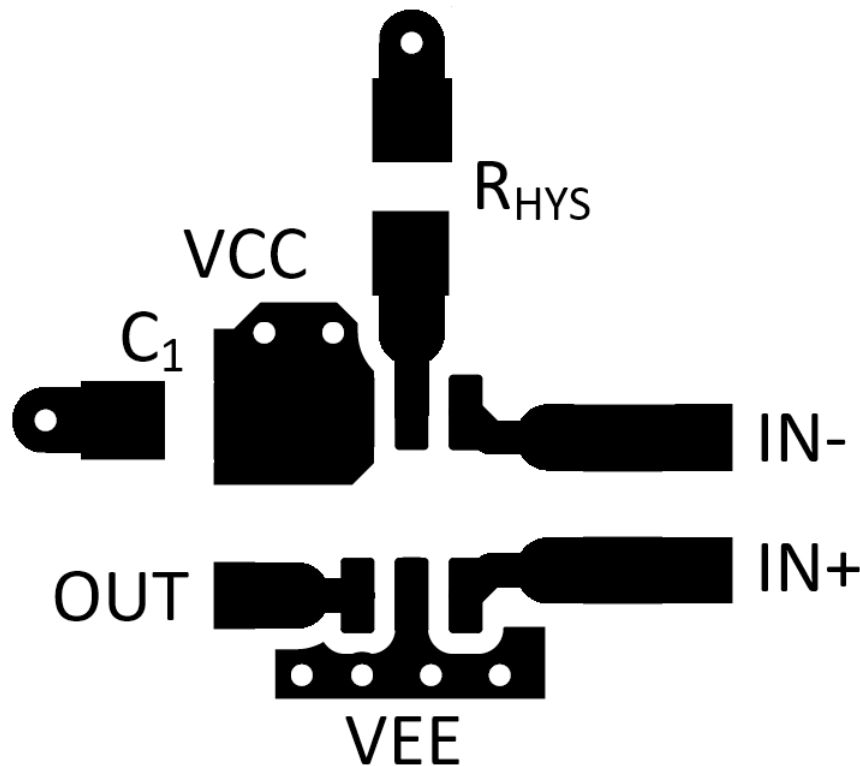

☒ 9-1. TLV3603-EP Layout Example

10 Device and Documentation Support

10.1 Device Support

10.1.1 Development Support

LIDAR Pulsed Time of Flight Reference Design

10.2 ドキュメントの更新通知を受け取る方法

ドキュメントの更新についての通知を受け取るには、www.tij.co.jp のデバイス製品フォルダを開いてください。[通知] をクリックして登録すると、変更されたすべての製品情報に関するダイジェストを毎週受け取ることができます。変更の詳細については、改訂されたドキュメントに含まれている改訂履歴をご覧ください。

10.3 サポート・リソース

テキサス・インスツルメンツ E2E™ サポート・フォーラムは、エンジニアが検証済みの回答と設計に関するヒントをエキスパートから迅速かつ直接得ることができる場所です。既存の回答を検索したり、独自の質問をしたりすることで、設計に必要な支援を迅速に得ることができます。

リンクされているコンテンツは、各寄稿者により「現状のまま」提供されるものです。これらはテキサス・インスツルメンツの仕様を構成するものではなく、必ずしもテキサス・インスツルメンツの見解を反映したものではありません。テキサス・インスツルメンツの[使用条件](#)を参照してください。

10.4 Trademarks

テキサス・インスツルメンツ E2E™ is a trademark of Texas Instruments.
すべての商標は、それぞれの所有者に帰属します。

10.5 静電気放電に関する注意事項



この IC は、ESD によって破損する可能性があります。テキサス・インスツルメンツは、IC を取り扱う際には常に適切な注意を払うことを推奨します。正しい取り扱いおよび設置手順に従わない場合、デバイスを破損するおそれがあります。

ESD による破損は、わずかな性能低下からデバイスの完全な故障まで多岐にわたります。精密な IC の場合、パラメータがわずかに変化するだけで公表されている仕様から外れる可能性があるため、破損が発生しやすくなっています。

10.6 用語集

[テキサス・インスツルメンツ用語集](#) この用語集には、用語や略語の一覧および定義が記載されています。

11 Revision History

資料番号末尾の英字は改訂を表しています。その改訂履歴は英語版に準じています。

DATE	REVISION	NOTES
September 2024	*	Initial Release

12 Mechanical, Packaging, and Orderable Information

The following pages include mechanical, packaging, and orderable information. This information is the most current data available for the designated devices. This data is subject to change without notice and revision of this document. For browser-based versions of this data sheet, refer to the left-hand navigation.

重要なお知らせと免責事項

テキサス・インスツルメンツは、技術データと信頼性データ (データシートを含みます)、設計リソース (リファレンス デザインを含みます)、アプリケーションや設計に関する各種アドバイス、Web ツール、安全性情報、その他のリソースを、欠陥が存在する可能性のある「現状のまま」提供しており、商品性および特定目的に対する適合性の黙示保証、第三者の知的財産権の非侵害保証を含むいかなる保証も、明示的または黙示的にかかわらず拒否します。

これらのリソースは、テキサス・インスツルメンツ製品を使用する設計の経験を積んだ開発者への提供を意図したものです。(1) お客様のアプリケーションに適した テキサス・インスツルメンツ製品の選定、(2) お客様のアプリケーションの設計、検証、試験、(3) お客様のアプリケーションに該当する各種規格や、その他のあらゆる安全性、セキュリティ、規制、または他の要件への確実な適合に関する責任を、お客様のみが単独で負うものとします。

上記の各種リソースは、予告なく変更される可能性があります。これらのリソースは、リソースで説明されている テキサス・インスツルメンツ製品を使用するアプリケーションの開発の目的でのみ、テキサス・インスツルメンツはその使用をお客様に許諾します。これらのリソースに関して、他の目的で複製することや掲載することは禁止されています。テキサス・インスツルメンツや第三者の知的財産権のライセンスが付与されている訳ではありません。お客様は、これらのリソースを自身で使用した結果発生するあらゆる申し立て、損害、費用、損失、責任について、テキサス・インスツルメンツおよびその代理人を完全に補償するものとし、テキサス・インスツルメンツは一切の責任を拒否します。

テキサス・インスツルメンツの製品は、[テキサス・インスツルメンツの販売条件](#)、または [ti.com](https://www.ti.com) やかかる テキサス・インスツルメンツ製品の関連資料などのいずれかを通じて提供する適用可能な条項の下で提供されています。テキサス・インスツルメンツがこれらのリソースを提供することは、適用されるテキサス・インスツルメンツの保証または他の保証の放棄の拡大や変更を意味するものではありません。

お客様がいかなる追加条項または代替条項を提案した場合でも、テキサス・インスツルメンツはそれらに異議を唱え、拒否します。

郵送先住所: Texas Instruments, Post Office Box 655303, Dallas, Texas 75265

Copyright © 2024, Texas Instruments Incorporated

PACKAGING INFORMATION

Orderable part number	Status (1)	Material type (2)	Package Pins	Package qty Carrier	RoHS (3)	Lead finish/ Ball material (4)	MSL rating/ Peak reflow (5)	Op temp (°C)	Part marking (6)
TLV3603MDBVREP	Active	Production	SOT-23 (DBV) 6	3000 LARGE T&R	Yes	NIPDAU	Level-1-260C-UNLIM	-55 to 125	3IJW
TLV3603MDBVTEP	Active	Production	SOT-23 (DBV) 6	250 SMALL T&R	Yes	NIPDAU	Level-1-260C-UNLIM	-55 to 125	3IJW
V62/24633-01XE	Active	Production	SOT-23 (DBV) 6	3000 LARGE T&R	Yes	NIPDAU	Level-1-260C-UNLIM	-55 to 125	3IJW

(1) **Status:** For more details on status, see our [product life cycle](#).

(2) **Material type:** When designated, preproduction parts are prototypes/experimental devices, and are not yet approved or released for full production. Testing and final process, including without limitation quality assurance, reliability performance testing, and/or process qualification, may not yet be complete, and this item is subject to further changes or possible discontinuation. If available for ordering, purchases will be subject to an additional waiver at checkout, and are intended for early internal evaluation purposes only. These items are sold without warranties of any kind.

(3) **RoHS values:** Yes, No, RoHS Exempt. See the [TI RoHS Statement](#) for additional information and value definition.

(4) **Lead finish/Ball material:** Parts may have multiple material finish options. Finish options are separated by a vertical ruled line. Lead finish/Ball material values may wrap to two lines if the finish value exceeds the maximum column width.

(5) **MSL rating/Peak reflow:** The moisture sensitivity level ratings and peak solder (reflow) temperatures. In the event that a part has multiple moisture sensitivity ratings, only the lowest level per JEDEC standards is shown. Refer to the shipping label for the actual reflow temperature that will be used to mount the part to the printed circuit board.

(6) **Part marking:** There may be an additional marking, which relates to the logo, the lot trace code information, or the environmental category of the part.

Multiple part markings will be inside parentheses. Only one part marking contained in parentheses and separated by a "-" will appear on a part. If a line is indented then it is a continuation of the previous line and the two combined represent the entire part marking for that device.

Important Information and Disclaimer: The information provided on this page represents TI's knowledge and belief as of the date that it is provided. TI bases its knowledge and belief on information provided by third parties, and makes no representation or warranty as to the accuracy of such information. Efforts are underway to better integrate information from third parties. TI has taken and continues to take reasonable steps to provide representative and accurate information but may not have conducted destructive testing or chemical analysis on incoming materials and chemicals. TI and TI suppliers consider certain information to be proprietary, and thus CAS numbers and other limited information may not be available for release.

In no event shall TI's liability arising out of such information exceed the total purchase price of the TI part(s) at issue in this document sold by TI to Customer on an annual basis.

OTHER QUALIFIED VERSIONS OF TLV3603-EP :

- Catalog : [TLV3603](#)

- Automotive : [TLV3603-Q1](#)

NOTE: Qualified Version Definitions:

- Catalog - TI's standard catalog product
- Automotive - Q100 devices qualified for high-reliability automotive applications targeting zero defects

DBV0006A



PACKAGE OUTLINE

SOT-23 - 1.45 mm max height

SMALL OUTLINE TRANSISTOR



4214840/G 08/2024

NOTES:

1. All linear dimensions are in millimeters. Any dimensions in parenthesis are for reference only. Dimensioning and tolerancing per ASME Y14.5M.
2. This drawing is subject to change without notice.
3. Body dimensions do not include mold flash or protrusion. Mold flash and protrusion shall not exceed 0.25 per side.
4. Leads 1,2,3 may be wider than leads 4,5,6 for package orientation.
5. Reference JEDEC MO-178.

EXAMPLE BOARD LAYOUT

DBV0006A

SOT-23 - 1.45 mm max height

SMALL OUTLINE TRANSISTOR



LAND PATTERN EXAMPLE
EXPOSED METAL SHOWN
SCALE:15X



SOLDER MASK DETAILS

4214840/G 08/2024

NOTES: (continued)

- 6. Publication IPC-7351 may have alternate designs.
- 7. Solder mask tolerances between and around signal pads can vary based on board fabrication site.

EXAMPLE STENCIL DESIGN

DBV0006A

SOT-23 - 1.45 mm max height

SMALL OUTLINE TRANSISTOR



SOLDER PASTE EXAMPLE
BASED ON 0.125 mm THICK STENCIL
SCALE:15X

4214840/G 08/2024

NOTES: (continued)

8. Laser cutting apertures with trapezoidal walls and rounded corners may offer better paste release. IPC-7525 may have alternate design recommendations.
9. Board assembly site may have different recommendations for stencil design.

重要なお知らせと免責事項

TI は、技術データと信頼性データ (データシートを含みます)、設計リソース (リファレンス デザインを含みます)、アプリケーションや設計に関する各種アドバイス、Web ツール、安全性情報、その他のリソースを、欠陥が存在する可能性のある「現状のまま」提供しており、商品性および特定目的に対する適合性の黙示保証、第三者の知的財産権の非侵害保証を含むいかなる保証も、明示的または黙示的にかかわらず拒否します。

これらのリソースは、TI 製品を使用する設計の経験を積んだ開発者への提供を意図したものです。(1) お客様のアプリケーションに適した TI 製品の選定、(2) お客様のアプリケーションの設計、検証、試験、(3) お客様のアプリケーションに該当する各種規格や、その他のあらゆる安全性、セキュリティ、規制、または他の要件への確実な適合に関する責任を、お客様のみが単独で負うものとし、

上記の各種リソースは、予告なく変更される可能性があります。これらのリソースは、リソースで説明されている TI 製品を使用するアプリケーションの開発の目的でのみ、TI はその使用をお客様に許諾します。これらのリソースに関して、他の目的で複製することや掲載することは禁止されています。TI や第三者の知的財産権のライセンスが付与されている訳ではありません。お客様は、これらのリソースを自身で使用した結果発生するあらゆる申し立て、損害、費用、損失、責任について、TI およびその代理人を完全に補償するものとし、TI は一切の責任を拒否します。

TI の製品は、[TI の販売条件](#)、[TI の総合的な品質ガイドライン](#)、[ti.com](#) または TI 製品などに関連して提供される他の適用条件に従い提供されます。TI がこれらのリソースを提供することは、適用される TI の保証または他の保証の放棄の拡大や変更を意味するものではありません。TI がカスタム、またはカスタマー仕様として明示的に指定していない限り、TI の製品は標準的なカタログに掲載される汎用機器です。

お客様がいかなる追加条項または代替条項を提案する場合も、TI はそれらに異議を唱え、拒否します。

Copyright © 2026, Texas Instruments Incorporated

最終更新日 : 2025 年 10 月