

## TMUX612x ±16.5V、低容量、低リーク電流、 高精度のデュアル SPST スイッチ

### 1 特長

- 広い電源電圧範囲: ±5V ~ ±16.5 V (デュアル)、10V ~ 16.5V (シングル)
- すべてのピンで、JEDEC Class II Level A 準拠の 100mA を満たすラッチアップ性能
- 小さいオン容量: 4.2pF
- 低い入力リーク: 0.5pA
- 少ない電荷注入: 0.51pC
- レール・ツー・レール動作
- 低オン抵抗: 120Ω
- 高速なスイッチ・ターンオン時間 68ns
- Break-Before-Make のスイッチング動作 (TMUX6123)
- SELx ピンを内蔵プルダウンにより V<sub>DD</sub> に接続可能
- ロジック・レベル: 2V ~ V<sub>DD</sub>
- 低消費電流: 16μA
- 人体モデル (HBM) ESD 保護: すべてのピンで ±2kV
- 業界標準の VSSOP パッケージ

### 2 アプリケーション

- ファクトリ・オートメーションと産業プロセス制御
- プログラマブル・ロジック・コントローラ (PLC)
- アナログ入力モジュール
- ATE 試験装置
- デジタル・マルチメータ
- バッテリ・モニタリング・システム

### 3 概要

TMUX6121, TMUX6122, TMUX6123 デバイスは、最新の CMOS (相補型金属酸化膜半導体) デバイスで、2 つの SPST (単極単投) スイッチを独立に選択可能です。このデバイスは、デュアル電源 (±5V ~ ±16.5V)、シングル電源 (10V ~ 16.5V)、非対称電源のいずれでも適切に動作します。すべてのデジタル入力はスレッシュホールドが TTL (Transistor-Transistor Logic) 互換で、TTL および CMOS 両方のロジックとの互換性が保証されています。

スイッチは、TMUX6121 ではデジタル制御入力のロジック 1 でオンになります。TMUX6122 のスイッチをオンにするには、ロジック 0 が必要です。TMUX6123 のスイッチの 1 つは TMUX6121 と同様のデジタル制御ロジックで、もう 1 つのスイッチはロジックが反転しています。TMUX6123 は、Break-Before-Make のスイッチングを行うため、クロスポイントのスイッチング・アプリケーションに使用できます。

TMUX6121, TMUX6122, TMUX6123 は、高精度スイッチおよびマルチプレクサのデバイス・ファミリの製品です。これらのデバイスはリーク電流と電荷注入が非常に小さいため、高精度の測定アプリケーションに使用可能です。消費電流が 16μA と低いいため、携帯型アプリケーションにも使用できます。

#### 製品情報<sup>(1)</sup>

部品番号	パッケージ	本体サイズ (公称)
TMUX6121	VSSOP (10)	3.00mm × 3.00mm
TMUX6122		
TMUX6123		

(1) 利用可能なすべてのパッケージについては、データシートの末尾にあるパッケージ・オプションについての付録を参照してください。

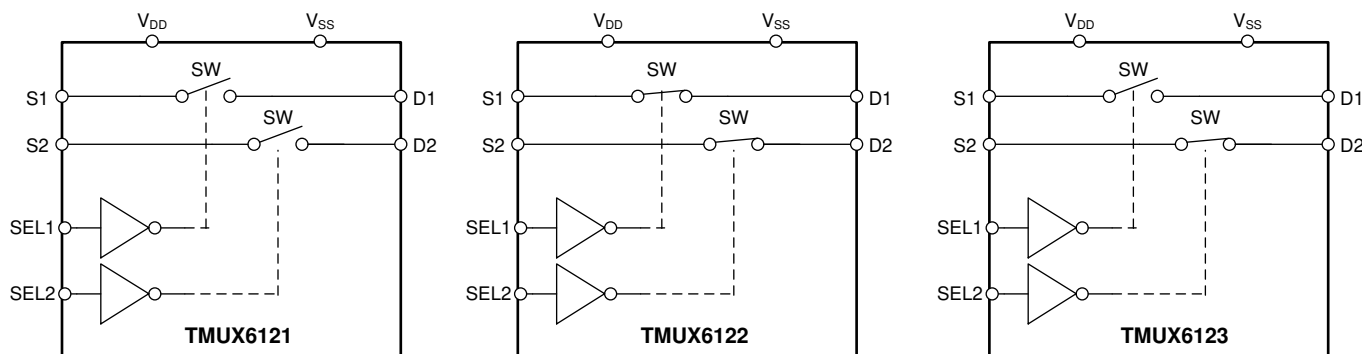

ALL SWITCHES SHOWN FOR A LOGIC 0 INPUT

### 概略回路図



## Table of Contents

<b>1 特長</b> .....	1	8.3 Feature Description.....	18
<b>2 アプリケーション</b> .....	1	8.4 Device Functional Modes.....	20
<b>3 概要</b> .....	1	<b>9 Application and Implementation</b> .....	21
<b>4 Revision History</b> .....	2	9.1 Application Information.....	21
<b>5 Pin Configuration and Functions</b> .....	3	9.2 Typical Application.....	21
<b>6 Specifications</b> .....	4	<b>10 Power Supply Recommendations</b> .....	23
6.1 Absolute Maximum Ratings.....	4	<b>11 Layout</b> .....	23
6.2 ESD Ratings.....	4	11.1 Layout Guidelines.....	23
6.3 Thermal Information.....	4	11.2 Layout Example.....	23
6.4 Recommended Operating Conditions.....	5	<b>12 Device and Documentation Support</b> .....	24
6.5 Electrical Characteristics (Dual Supplies: $\pm 15$ V).....	5	12.1 Documentation Support.....	24
6.6 Switching Characteristics (Dual Supplies: $\pm 15$ V).....	6	12.2 Receiving Notification of Documentation Updates.....	24
6.7 Electrical Characteristics (Single Supply: 12 V).....	6	12.3 サポート・リソース.....	24
6.8 Switching Characteristics (Single Supply: 12 V).....	7	12.4 Trademarks.....	24
<b>7 Parameter Measurement Information</b> .....	12	12.5 Electrostatic Discharge Caution.....	24
7.1 Truth Tables.....	12	12.6 Glossary.....	24
<b>8 Detailed Description</b> .....	13	<b>13 Mechanical, Packaging, and Orderable Information</b> .....	24
8.1 Overview.....	13		
8.2 Functional Block Diagram.....	18		

## 4 Revision History

資料番号末尾の英字は改訂を表しています。その改訂履歴は英語版に準じています。

<b>Changes from Revision * (December 2018) to Revision A (July 2022)</b>	<b>Page</b>
• 文書全体にわたって表、図、相互参照の採番方法を更新.....	1

## 5 Pin Configuration and Functions



图 5-1. DGS Package, 10-Pin VSSOP (Top View)

表 5-1. Pin Functions

PIN		TYPE <sup>(1)</sup>	DESCRIPTION
NAME	NO.		
SEL1	1	I	Logic control input 1.
S1	2	I/O	Source pin 1. Can be an input or output.
D1	3	I/O	Drain pin 1. Can be an input or output.
D2	4	I/O	Drain pin 2. Can be an input or output.
S2	5	I/O	Source pin 2. Can be an input or output.
V <sub>SS</sub>	6	P	Negative power supply. This pin is the most negative power-supply potential. In single-supply applications, this pin can be connected to ground. For reliable operation, connect a decoupling capacitor ranging from 0.1 $\mu$ F to 10 $\mu$ F between V <sub>SS</sub> and GND.
NC	7	No Connect	No internal connection.
GND	8	P	Ground (0 V) reference.
V <sub>DD</sub>	9	P	Positive power supply. This pin is the most positive power-supply potential. For reliable operation, connect a decoupling capacitor ranging from 0.1 $\mu$ F to 10 $\mu$ F between V <sub>DD</sub> and GND.
SEL2	10	I	Logic control input 2.

(1) I = input, O = output, P = power

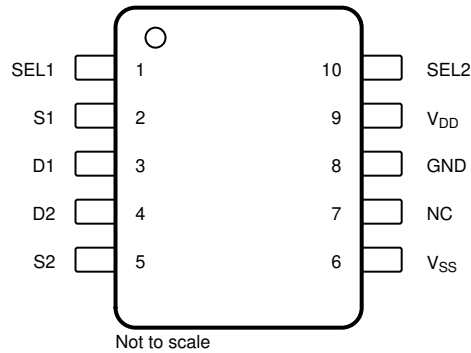
## 6 Specifications

### 6.1 Absolute Maximum Ratings

over operating free-air temperature range (unless otherwise noted)<sup>(1)</sup>

		MIN	MAX	UNIT
V <sub>DD</sub> to V <sub>SS</sub>	Supply voltage		36	V
V <sub>DD</sub> to GND		-0.3	18	V
V <sub>SS</sub> to GND		-18	0.3	V
V <sub>DIG</sub>	Digital input pin (SEL1, SEL2) voltage	GND - 0.3	V <sub>DD</sub> + 0.3	V
I <sub>DIG</sub>	Digital input pin (SEL1, SEL2) current	-30	30	mA
V <sub>ANA_IN</sub>	Analog input pin (Sx) voltage	V <sub>SS</sub> - 0.3	V <sub>DD</sub> + 0.3	V
I <sub>ANA_IN</sub>	Analog input pin (Sx) current	-30	30	mA
V <sub>ANA_OUT</sub>	Analog output pin (Dx) voltage	V <sub>SS</sub> - 0.3	V <sub>DD</sub> + 0.3	V
I <sub>ANA_OUT</sub>	Analog output pin (Dx) current	-30	30	mA
T <sub>A</sub>	Ambient temperature	-55	140	°C
T <sub>J</sub>	Junction temperature		150	°C
T <sub>stg</sub>	Storage temperature	-65	150	°C

- (1) Stresses beyond those listed under *Absolute Maximum Rating* may cause permanent damage to the device. These are stress ratings only, which do not imply functional operation of the device at these or any other conditions beyond those indicated under *Recommended Operating Condition*. Exposure to absolute-maximum-rated conditions for extended periods may affect device reliability.

### 6.2 ESD Ratings

		VALUE	UNIT
V <sub>(ESD)</sub>	Electrostatic discharge	Human body model (HBM), per ANSI/ESDA/ JEDEC JS-001, all pins <sup>(1)</sup>	V
		Charged device model (CDM), per JEDEC specification JESD22-C101, all pins <sup>(2)</sup>	

- (1) JEDEC document JEP155 states that 500-V HBM allows safe manufacturing with a standard ESD control process.  
 (2) JEDEC document JEP157 states that 250-V CDM allows safe manufacturing with a standard ESD control process.

### 6.3 Thermal Information

THERMAL METRIC <sup>(1)</sup>		TMUX6121/ TMUX6122/ TMUX6123	UNIT
		DGS (VSSOP)	
		10 PINS	
R <sub>θJA</sub>	Junction-to-ambient thermal resistance	180.7	°C/W
R <sub>θJC(top)</sub>	Junction-to-case (top) thermal resistance	66.2	°C/W
R <sub>θJB</sub>	Junction-to-board thermal resistance	103.2	°C/W
Ψ <sub>JT</sub>	Junction-to-top characterization parameter	11.2	°C/W
Ψ <sub>JB</sub>	Junction-to-board characterization parameter	101.3	°C/W
R <sub>θJC(bot)</sub>	Junction-to-case (bottom) thermal resistance	N/A	°C/W

- (1) For more information about traditional and new thermal metrics, see the [Semiconductor and IC Package Thermal Metrics](#) application report.

## 6.4 Recommended Operating Conditions

over operating free-air temperature range (unless otherwise noted)

		MIN	NOM	MAX	UNIT
$V_{DD}$ to $V_{SS}$ <sup>(1)</sup>	Power supply voltage differential	10		33	V
$V_{DD}$ to GND	Positive power supply voltage (single supply, $V_{SS} = 0$ V)	10		16.5	V
$V_{DD}$ to GND	Positive power supply voltage (dual supply)	5		16.5	V
$V_{SS}$ to GND	Negative power supply voltage (dual supply)	-16.5		-5	V
$V_S$	Source pins voltage <sup>(2)</sup>	$V_{SS}$		$V_{DD}$	V
$V_D$	Drain pin voltage	$V_{SS}$		$V_{DD}$	V
$V_{SEL}$	Select pin (SEL1, SEL2) voltage	$V_{SS}$		$V_{DD}$	V
$I_{CH}$	Channel current ( $T_A = 25^\circ\text{C}$ )	-25		25	mA
$T_A$	Ambient temperature	-40		125	$^\circ\text{C}$

(1)  $V_{DD}$  and  $V_{SS}$  can be any value as long as  $10\text{ V} \leq (V_{DD} - V_{SS}) \leq 33\text{ V}$ .

(2)  $V_S$  is the voltage on both S pins.

## 6.5 Electrical Characteristics (Dual Supplies: $\pm 15$ V)

at  $T_A = 25^\circ\text{C}$ ,  $V_{DD} = 15\text{ V}$ , and  $V_{SS} = -15\text{ V}$  (unless otherwise noted)

PARAMETER		TEST CONDITIONS		MIN	TYP	MAX	UNIT	
<b>ANALOG SWITCH</b>								
$V_A$	Analog signal range	$T_A = -40^\circ\text{C}$ to $+125^\circ\text{C}$	$T_A = -40^\circ\text{C}$ to $+125^\circ\text{C}$	$V_{SS}$		$V_{DD}$	V	
$R_{ON}$	On-resistance	$V_S = 0\text{ V}$ , $I_S = 1\text{ mA}$			120	135	$\Omega$	
		$V_S = \pm 10\text{ V}$ , $I_S = 1\text{ mA}$			140	165	$\Omega$	
		$V_S = \pm 10\text{ V}$ , $I_S = 1\text{ mA}$		$T_A = -40^\circ\text{C}$ to $+85^\circ\text{C}$			210	$\Omega$
		$V_S = \pm 10\text{ V}$ , $I_S = 1\text{ mA}$		$T_A = -40^\circ\text{C}$ to $+125^\circ\text{C}$			245	$\Omega$
$\Delta R_{ON}$	On-resistance mismatch between channels	$V_S = \pm 10\text{ V}$ , $I_S = 1\text{ mA}$			2.4	6	$\Omega$	
		$V_S = \pm 10\text{ V}$ , $I_S = 1\text{ mA}$		$T_A = -40^\circ\text{C}$ to $+85^\circ\text{C}$			9	$\Omega$
						11	$\Omega$	
$R_{ON\_FLAT}$	On-resistance flatness	$V_S = -10\text{ V}$ , $0\text{ V}$ , $+10\text{ V}$ , $I_S = 1\text{ mA}$			22	45	$\Omega$	
		$V_S = -10\text{ V}$ , $0\text{ V}$ , $+10\text{ V}$ , $I_S = 1\text{ mA}$		$T_A = -40^\circ\text{C}$ to $+85^\circ\text{C}$			47	$\Omega$
		$V_S = -10\text{ V}$ , $0\text{ V}$ , $+10\text{ V}$ , $I_S = 1\text{ mA}$		$T_A = -40^\circ\text{C}$ to $+125^\circ\text{C}$			49	$\Omega$
$R_{ON\_DRIFT}$	On-resistance drift	$V_S = 0\text{ V}$			0.5		$\%/^\circ\text{C}$	
$I_{S(OFF)}$	Source off leakage current <sup>(1)</sup>	Switch state is off, $V_S = +10\text{ V}/-10\text{ V}$ , $V_D = -10\text{ V}/+10\text{ V}$			-0.02	0.005	0.02	nA
				$T_A = -40^\circ\text{C}$ to $+85^\circ\text{C}$			0.05	nA
				$T_A = -40^\circ\text{C}$ to $+125^\circ\text{C}$			-1	0.2
$I_{D(OFF)}$	Drain off leakage current <sup>(1)</sup>	Switch state is off, $V_S = +10\text{ V}/-10\text{ V}$ , $V_D = -10\text{ V}/+10\text{ V}$			-0.02	0.005	0.02	nA
				$T_A = -40^\circ\text{C}$ to $+85^\circ\text{C}$			0.05	nA
				$T_A = -40^\circ\text{C}$ to $+125^\circ\text{C}$			-1	0.2
$I_{D(ON)}$	Drain on leakage current	Switch state is on, $V_S = +10\text{ V}/-10\text{ V}$ , $V_D = -10\text{ V}/+10\text{ V}$			-0.04	0.01	0.04	nA
				$T_A = -40^\circ\text{C}$ to $+85^\circ\text{C}$			0.1	nA
				$T_A = -40^\circ\text{C}$ to $+125^\circ\text{C}$			-1.8	0.4
<b>DIGITAL INPUT (SELx pins)</b>								
$V_{IH}$	Logic voltage high			2			V	
$V_{IL}$	Logic voltage low					0.8	V	
$R_{PD(IN)}$	Pull-down resistance on INx pins				6		M $\Omega$	
<b>POWER SUPPLY</b>								

## 6.5 Electrical Characteristics (Dual Supplies: ±15 V) (continued)

at  $T_A = 25^\circ\text{C}$ ,  $V_{DD} = 15\text{ V}$ , and  $V_{SS} = -15\text{ V}$  (unless otherwise noted)

PARAMETER		TEST CONDITIONS		MIN	TYP	MAX	UNIT
$I_{DD}$	$V_{DD}$ supply current	$V_A = 0\text{ V}$ or $3.3\text{ V}$ , $V_S = 0\text{ V}$			16	21	$\mu\text{A}$
			$T_A = -40^\circ\text{C}$ to $+85^\circ\text{C}$			22	$\mu\text{A}$
			$T_A = -40^\circ\text{C}$ to $+125^\circ\text{C}$			23	$\mu\text{A}$
$I_{SS}$	$V_{SS}$ supply current	$V_A = 0\text{ V}$ or $3.3\text{ V}$ , $V_S = 0\text{ V}$			7	10	$\mu\text{A}$
			$T_A = -40^\circ\text{C}$ to $+85^\circ\text{C}$			11	$\mu\text{A}$
			$T_A = -40^\circ\text{C}$ to $+125^\circ\text{C}$			12	$\mu\text{A}$

(1) When  $V_S$  is positive,  $V_D$  is negative, and vice versa.

## 6.6 Switching Characteristics (Dual Supplies: ±15 V)

at  $T_A = 25^\circ\text{C}$ ,  $V_{DD} = 15\text{ V}$ , and  $V_{SS} = -15\text{ V}$  (unless otherwise noted)

PARAMETER		TEST CONDITIONS		MIN	TYP	MAX	UNIT
$t_{ON}$	Switch turn-on time	$V_S = \pm 10\text{ V}$ , $R_L = 300\ \Omega$ , $C_L = 35\text{ pF}$			68	86	ns
			$V_S = \pm 10\text{ V}$ , $R_L = 300\ \Omega$ , $C_L = 35\text{ pF}$ , $T_A = -40^\circ\text{C}$ to $+85^\circ\text{C}$			110	ns
			$V_S = \pm 10\text{ V}$ , $R_L = 300\ \Omega$ , $C_L = 35\text{ pF}$ , $T_A = -40^\circ\text{C}$ to $+125^\circ\text{C}$			121	ns
$t_{OFF}$	Switch turn-off time	$V_S = \pm 10\text{ V}$ , $R_L = 300\ \Omega$ , $C_L = 35\text{ pF}$			57	76	ns
			$V_S = \pm 10\text{ V}$ , $R_L = 300\ \Omega$ , $C_L = 35\text{ pF}$ , $T_A = -40^\circ\text{C}$ to $+85^\circ\text{C}$			82	ns
			$V_S = \pm 10\text{ V}$ , $R_L = 300\ \Omega$ , $C_L = 35\text{ pF}$ , $T_A = -40^\circ\text{C}$ to $+125^\circ\text{C}$			85	ns
$t_{BBM}$	Break-before-make time delay (TMUX6123 Only)	$V_S = 10\text{ V}$ , $R_L = 300\ \Omega$ , $C_L = 35\text{ pF}$ , $T_A = -40^\circ\text{C}$ to $+125^\circ\text{C}$		20	40		ns
$Q_J$	Charge injection	$V_S = 0\text{ V}$ , $R_S = 0\ \Omega$ , $C_L = 1\text{ nF}$			0.51		pC
$O_{ISO}$	Off-isolation	$R_L = 50\ \Omega$ , $C_L = 5\text{ pF}$ , $f = 1\text{ MHz}$			-85		dB
$X_{TALK}$	Channel-to-channel crosstalk	$R_L = 50\ \Omega$ , $C_L = 5\text{ pF}$ , $f = 1\text{ MHz}$			-110		dB
$I_L$	Insertion loss	$R_L = 50\ \Omega$ , $C_L = 5\text{ pF}$ , $f = 1\text{ MHz}$			-7.7		dB
ACPSRR	AC Power Supply Rejection Ratio	$R_L = 10\text{ k}\Omega$ , $C_L = 5\text{ pF}$ , $V_{PP} = 0.62\text{ V}$ on $V_{DD}$ , $f = 1\text{ MHz}$			-61		dB
		$R_L = 10\text{ k}\Omega$ , $C_L = 5\text{ pF}$ , $V_{PP} = 0.62\text{ V}$ on $V_{SS}$ , $f = 1\text{ MHz}$			-61		dB
BW	-3 dB Bandwidth	$R_L = 50\ \Omega$ , $C_L = 5\text{ pF}$			630		MHz
THD	Total harmonic distortion + noise	$R_L = 10\text{ k}\Omega$ , $C_L = 5\text{ pF}$ , $f = 20\text{ Hz}$ to $20\text{ kHz}$			0.08		%
$C_{IN}$	Digital input capacitance	$V_{SELx} = 0\text{ V}$ or $V_{DD}$			1.2		pF
$C_{S(OFF)}$	Source off-capacitance	$V_S = 0\text{ V}$ , $f = 1\text{ MHz}$			1.9	2.5	pF
$C_{D(OFF)}$	Drain off-capacitance	$V_S = 0\text{ V}$ , $f = 1\text{ MHz}$			2.2	2.6	pF
$C_{S(ON)}$ , $C_{D(ON)}$	Source and drain on-capacitance	$V_S = 0\text{ V}$ , $f = 1\text{ MHz}$			4.2	5	pF

## 6.7 Electrical Characteristics (Single Supply: 12 V)

at  $T_A = 25^\circ\text{C}$ ,  $V_{DD} = 12\text{ V}$ , and  $V_{SS} = 0\text{ V}$  (unless otherwise noted)

PARAMETER		TEST CONDITIONS		MIN	TYP	MAX	UNIT
<b>ANALOG SWITCH</b>							
$V_A$	Analog signal range	$T_A = -40^\circ\text{C}$ to $+125^\circ\text{C}$		$V_{SS}$		$V_{DD}$	V
$R_{ON}$	On-resistance	$V_S = 10\text{ V}$ , $I_S = 1\text{ mA}$			230	265	$\Omega$
			$T_A = -40^\circ\text{C}$ to $+85^\circ\text{C}$			355	$\Omega$
			$T_A = -40^\circ\text{C}$ to $+125^\circ\text{C}$			405	$\Omega$

## 6.7 Electrical Characteristics (Single Supply: 12 V) (continued)

at  $T_A = 25^\circ\text{C}$ ,  $V_{DD} = 12\text{ V}$ , and  $V_{SS} = 0\text{ V}$  (unless otherwise noted)

PARAMETER		TEST CONDITIONS	MIN	TYP	MAX	UNIT				
$\Delta R_{ON}$	On-resistance mismatch between channels	$V_S = 10\text{ V}$ , $I_S = 1\text{ mA}$		1	9	$\Omega$				
			$T_A = -40^\circ\text{C}$ to $+85^\circ\text{C}$			12	$\Omega$			
			$T_A = -40^\circ\text{C}$ to $+125^\circ\text{C}$			14	$\Omega$			
$R_{ON\_DRIFT}$	On-resistance drift	$V_S = 0\text{ V}$		0.48		$\%/^\circ\text{C}$				
$I_{S(OFF)}$	Source off leakage current <sup>(1)</sup>	Switch state is off, $V_S = 10\text{ V}$ / $1\text{ V}$ , $V_D = 1\text{ V}$ / $10\text{ V}$		-0.02	0.005	0.02	nA			
			$T_A = -40^\circ\text{C}$ to $+85^\circ\text{C}$	-0.08		0.04	nA			
$I_{D(OFF)}$	Drain off leakage current <sup>(1)</sup>	Switch state is off, $V_S = 10\text{ V}$ / $1\text{ V}$ , $V_D = 1\text{ V}$ / $10\text{ V}$		-0.02	0.005	0.02	nA			
			$T_A = -40^\circ\text{C}$ to $+85^\circ\text{C}$	-0.08		0.04	nA			
$I_{D(ON)}$	Drain on leakage current	Switch state is on, $V_S =$ floating, $V_D = 1\text{ V}$ / $10\text{ V}$		-0.04	0.01	0.04	nA			
			$T_A = -40^\circ\text{C}$ to $+85^\circ\text{C}$	-0.16		0.08	nA			
						$T_A = -40^\circ\text{C}$ to $+125^\circ\text{C}$	-1.5		0.25	nA
<b>DIGITAL INPUT (SELx pins)</b>										
$V_{IH}$	Logic voltage high		2			V				
$V_{IL}$	Logic voltage low				0.8	V				
$R_{PD(IN)}$	Pull-down resistance on INx pins			6		M $\Omega$				
<b>POWER SUPPLY</b>										
$I_{DD}$	$V_{DD}$ supply current	$V_A = 0\text{ V}$ or $3.3\text{ V}$ , $V_S = 0\text{ V}$	$V_A = 0\text{ V}$ or $3.3\text{ V}$ , $V_S = 0\text{ V}$	11	14	$\mu\text{A}$				
			$V_A = 0\text{ V}$ or $3.3\text{ V}$ , $V_S = 0\text{ V}$			16	$\mu\text{A}$			
			$V_A = 0\text{ V}$ or $3.3\text{ V}$ , $V_S = 0\text{ V}$			17	$\mu\text{A}$			

(1) When  $V_S$  is positive,  $V_D$  is negative, and vice versa.

## 6.8 Switching Characteristics (Single Supply: 12 V)

at  $T_A = 25^\circ\text{C}$ ,  $V_{DD} = 12\text{ V}$ , and  $V_{SS} = 0\text{ V}$  (unless otherwise noted)

PARAMETER		TEST CONDITIONS	MIN	TYP	MAX	UNIT
$t_{ON}$	Switch turn-on time	$V_S = 8\text{ V}$ , $R_L = 300\ \Omega$ , $C_L = 35\text{ pF}$		74	82	ns
		$V_S = 8\text{ V}$ , $R_L = 300\ \Omega$ , $C_L = 35\text{ pF}$ , $T_A = -40^\circ\text{C}$ to $+85^\circ\text{C}$			89	ns
		$V_S = 8\text{ V}$ , $R_L = 300\ \Omega$ , $C_L = 35\text{ pF}$ , $T_A = -40^\circ\text{C}$ to $+125^\circ\text{C}$			93	ns
$t_{OFF}$	Switch turn-off time	$V_S = 8\text{ V}$ , $R_L = 300\ \Omega$ , $C_L = 35\text{ pF}$		56	75	ns
		$V_S = 8\text{ V}$ , $R_L = 300\ \Omega$ , $C_L = 35\text{ pF}$ , $T_A = -40^\circ\text{C}$ to $+85^\circ\text{C}$			83	ns
		$V_S = 8\text{ V}$ , $R_L = 300\ \Omega$ , $C_L = 35\text{ pF}$ , $T_A = -40^\circ\text{C}$ to $+125^\circ\text{C}$			85	ns
$t_{BBM}$	Break-before-make time delay (TMUX6123 only)	$V_S = 8\text{ V}$ , $R_L = 300\ \Omega$ , $C_L = 35\text{ pF}$ , $T_A = -40^\circ\text{C}$ to $+125^\circ\text{C}$	20	37		ns
$Q_J$	Charge injection	$V_S = 6\text{ V}$ , $R_S = 0\ \Omega$ , $C_L = 1\text{ nF}$		0.14		pC
$O_{ISO}$	Off-isolation	$R_L = 50\ \Omega$ , $C_L = 5\text{ pF}$ , $f = 1\text{ MHz}$		-85		dB
$X_{TALK}$	Channel-to-channel crosstalk	$R_L = 50\ \Omega$ , $C_L = 5\text{ pF}$ , $f = 1\text{ MHz}$		-115		dB
$I_L$	Insertion loss	$R_L = 50\ \Omega$ , $C_L = 5\text{ pF}$ , $f = 1\text{ MHz}$		-15		dB
ACPSRR	AC Power Supply Rejection Ratio	$R_L = 10\text{ k}\Omega$ , $C_L = 5\text{ pF}$ , $V_{PP} = 0.62\text{ V}$ , $f = 1\text{ MHz}$		-61		dB
BW	-3dB Bandwidth	$R_L = 50\ \Omega$ , $C_L = 5\text{ pF}$		500		MHz

## 6.8 Switching Characteristics (Single Supply: 12 V) (continued)

at  $T_A = 25^\circ\text{C}$ ,  $V_{DD} = 12\text{ V}$ , and  $V_{SS} = 0\text{ V}$  (unless otherwise noted)

PARAMETER		TEST CONDITIONS	MIN	TYP	MAX	UNIT
$C_{IN}$	Digital input capacitance	$V_{IN} = 0\text{ V or }V_{DD}$		1.3		pF
$C_{S(OFF)}$	Source off-capacitance	$V_S = 6\text{ V, }f = 1\text{ MHz}$		2.2	2.8	pF
$C_{D(OFF)}$	Drain off-capacitance	$V_S = 6\text{ V, }f = 1\text{ MHz}$		2.5	2.8	pF
$C_{S(ON)}$ , $C_{D(ON)}$	Source and drain on-capacitance	$V_S = 6\text{ V, }f = 1\text{ MHz}$		4.8	6.1	pF



## Typical Characteristics

at  $T_A = 25^\circ\text{C}$ ,  $V_{DD} = 15\text{ V}$ , and  $V_{SS} = -15\text{ V}$  (unless otherwise noted)

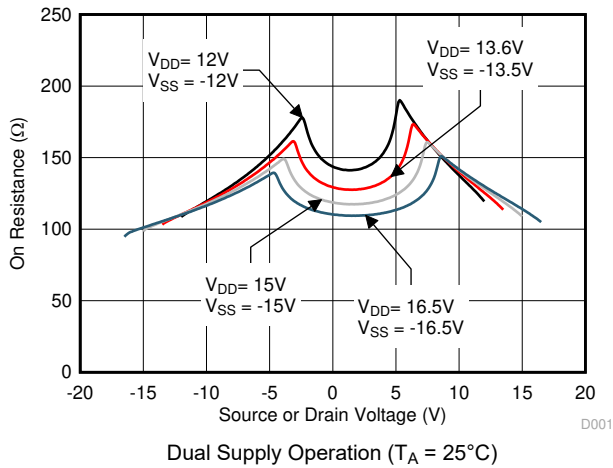

**6-1. On-Resistance vs Source or Drain Voltage**

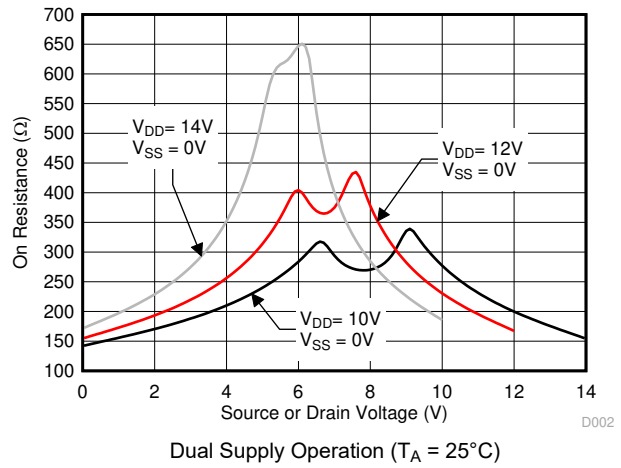

**6-2. On-Resistance vs Source or Drain Voltage**

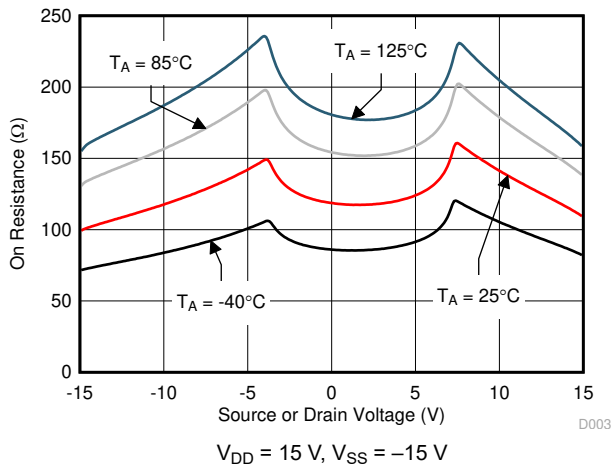

**6-3. On-Resistance vs Source or Drain Voltage**

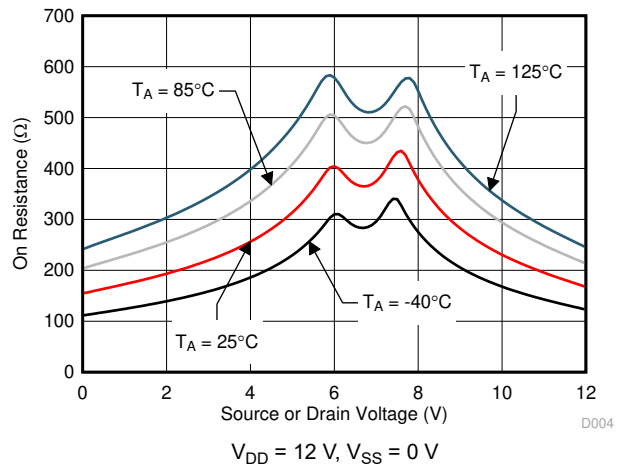

**6-4. On-Resistance vs Source or Drain Voltage**

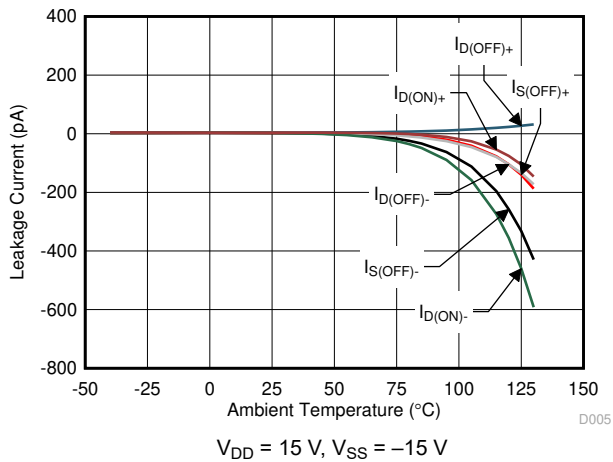

**6-5. Leakage Current vs Temperature**

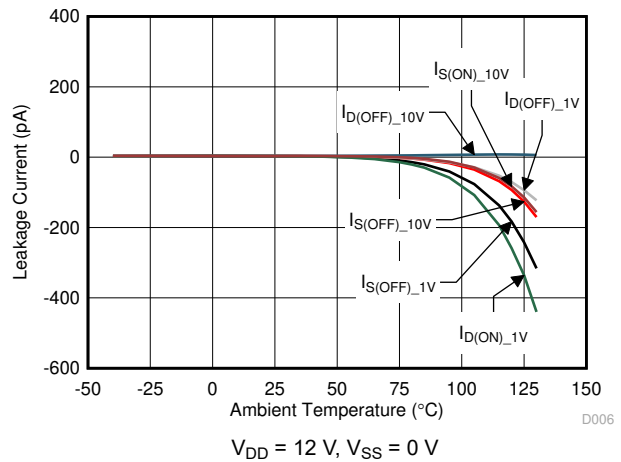

**6-6. Leakage Current vs Temperature**

## Typical Characteristics

at  $T_A = 25^\circ\text{C}$ ,  $V_{DD} = 15\text{ V}$ , and  $V_{SS} = -15\text{ V}$  (unless otherwise noted)

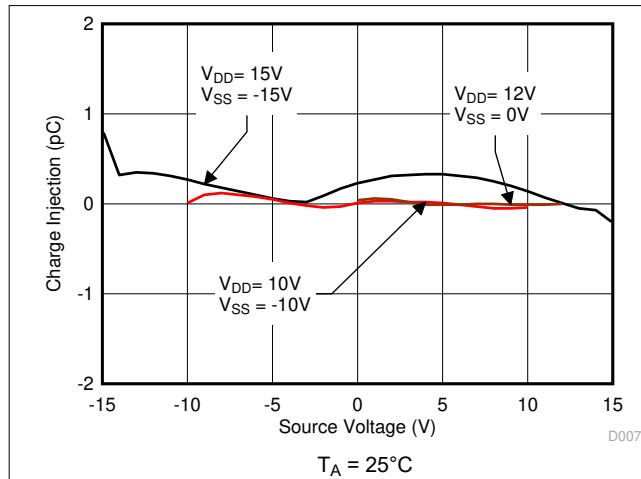

Figure 6-7. Charge Injection vs Source Voltage

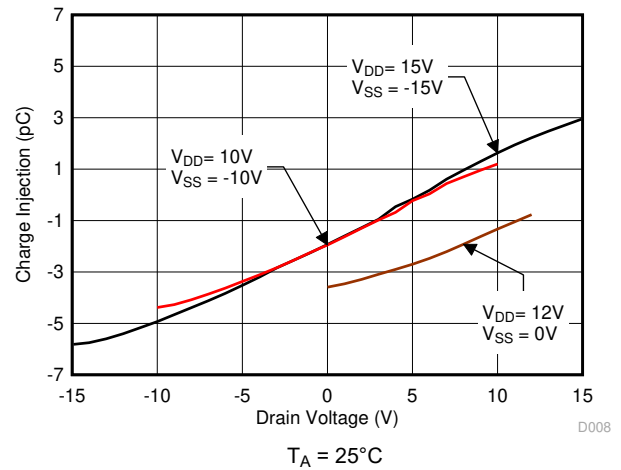

Figure 6-8. Charge Injection vs Drain Voltage

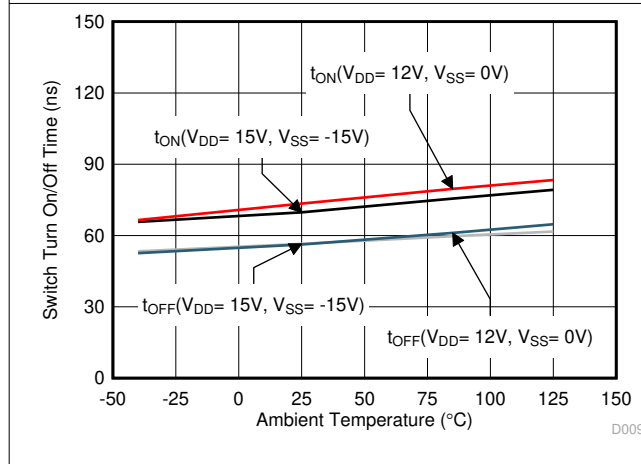

Figure 6-9. Turn-On and Turn-Off Times vs Temperature

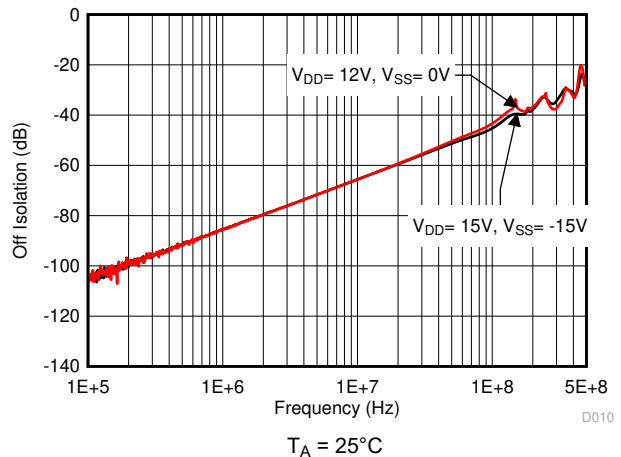

Figure 6-10. Off Isolation vs Frequency

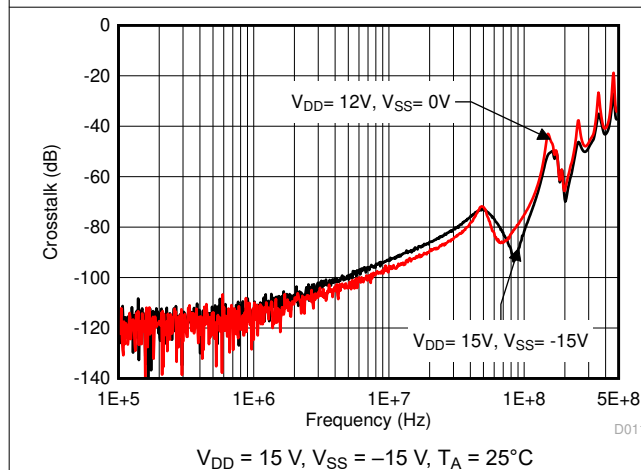

Figure 6-11. Crosstalk vs Frequency

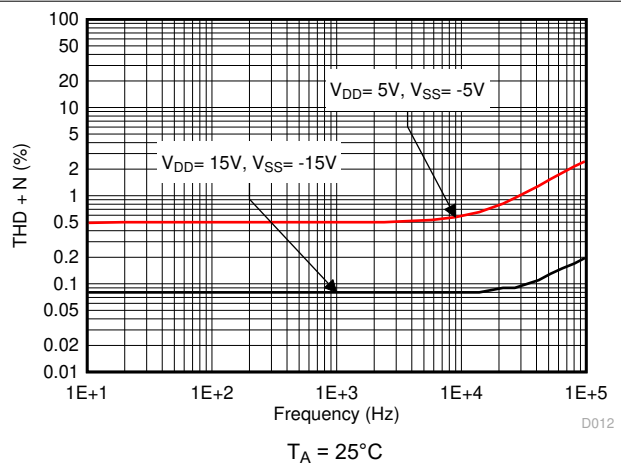
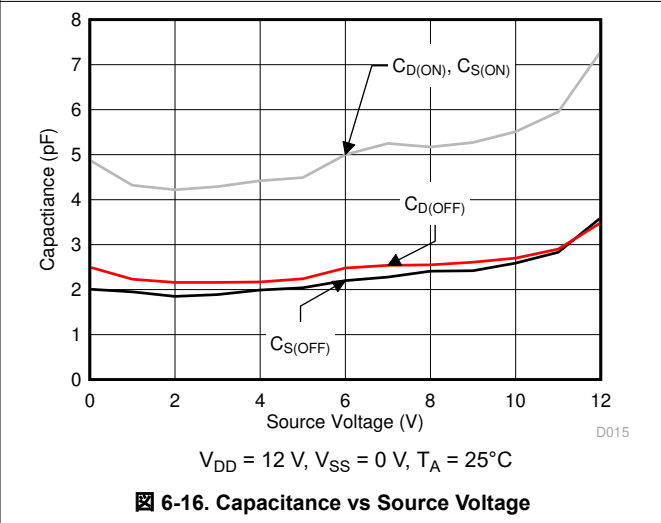
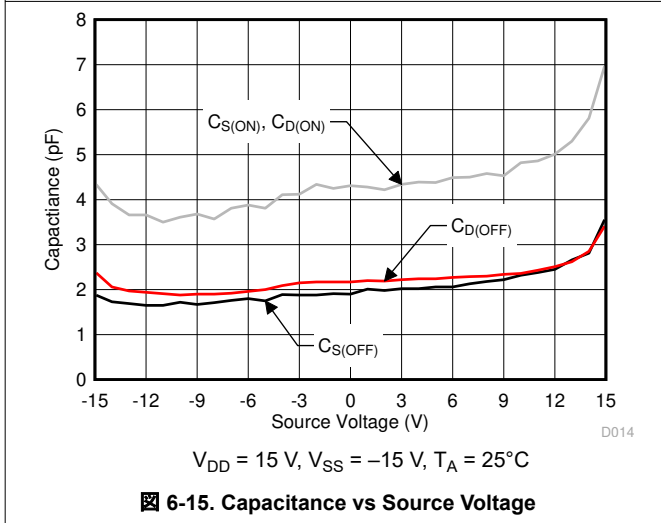
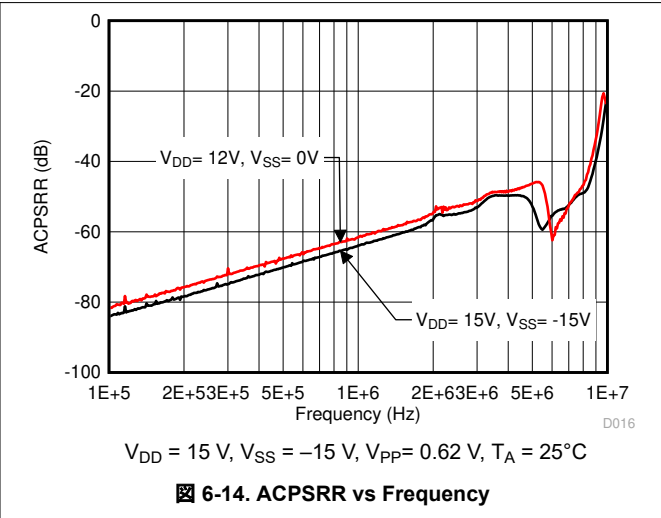
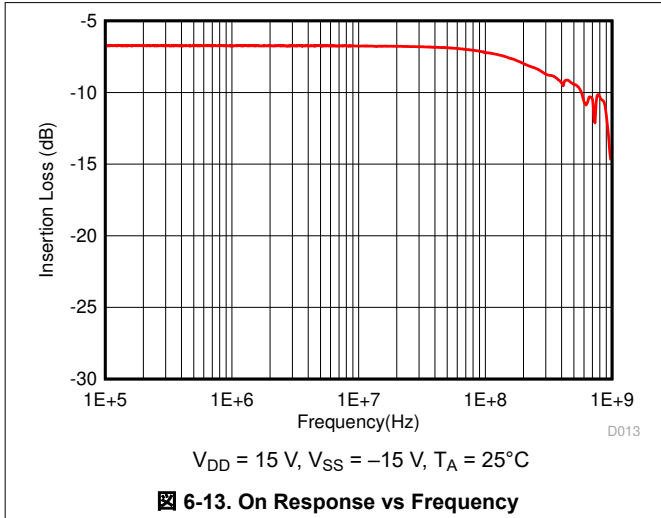

Figure 6-12. THD+N vs Frequency

## Typical Characteristics

at  $T_A = 25^\circ\text{C}$ ,  $V_{DD} = 15\text{ V}$ , and  $V_{SS} = -15\text{ V}$  (unless otherwise noted)



## 7 Parameter Measurement Information

### 7.1 Truth Tables

表 7-1, 表 7-2, and 表 7-3 show the truth tables for the TMUX6121, TMUX6122, and TMUX6123, respectively.

**表 7-1. TMUX6121 Truth Table**

SELx	STATE
0	All Switch OFF
1	All Switch ON

**表 7-2. TMUX6122 Truth Table**

SELx	STATE
0	All Switch ON
1	All Switch OFF

**表 7-3. TMUX6123 Truth Table**

SELx	STATE
0	Switch 1 OFF Switch 2 ON
1	Switch 1 ON Switch 2 OFF

## 8 Detailed Description

### 8.1 Overview

The TMUX6121, TMUX6122, and TMUX6123 are 2-channel single-pole/ single-throw (SPDT) switches that support dual supplies ( $\pm 5\text{ V}$  to  $\pm 16.5\text{ V}$ ) or single supply (10 V to 16.5 V) operation. Each channel of the switch is turned on or turned off based on the state of its corresponding SELx pin. [セクション 8.2](#) provides a top-level block diagram of the switches.

#### 8.1.1 On-Resistance

The on-resistance of the TMUX6121, TMUX6122, and TMUX6123 is the ohmic resistance across the source (Sx) and drain (D) pins of the device. The on-resistance varies with input voltage and supply voltage. The symbol  $R_{ON}$  is used to denote on-resistance. The measurement setup used to measure  $R_{ON}$  is shown in [図 8-1](#). Voltage (V) and current ( $I_{CH}$ ) are measured using this setup, and  $R_{ON}$  is computed as shown in [式 1](#):

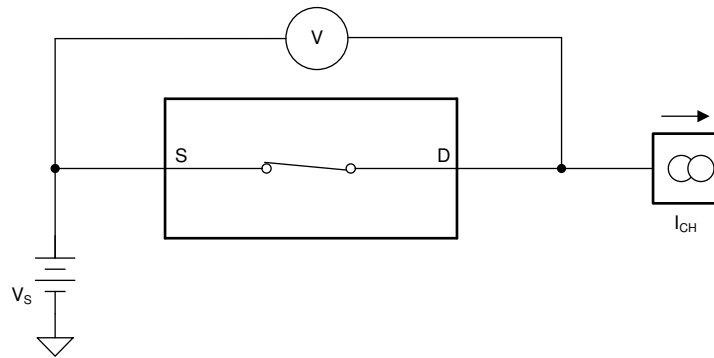

**図 8-1. On-Resistance Measurement Setup**

$$R_{ON} = V / I_{CH} \quad (1)$$

#### 8.1.2 Off-Leakage Current

There are two types of leakage currents associated with a switch during the off state:

1. Source off-leakage current
2. Drain off-leakage current

Source leakage current is defined as the leakage current flowing into or out of the source pin when the switch is off. This current is denoted by the symbol  $I_{S(OFF)}$ .

Drain leakage current is defined as the leakage current flowing into or out of the drain pin when the switch is off. This current is denoted by the symbol  $I_{D(OFF)}$ .

The setup used to measure both off-leakage currents is shown in [図 8-2](#).

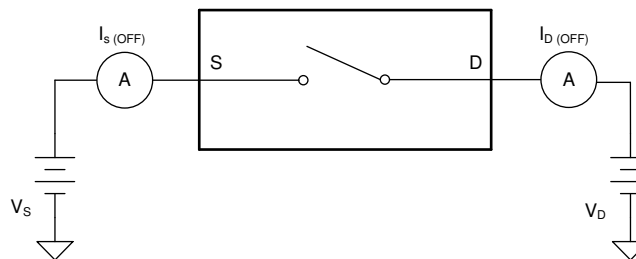

**図 8-2. Off-Leakage Measurement Setup**

### 8.1.3 On-Leakage Current

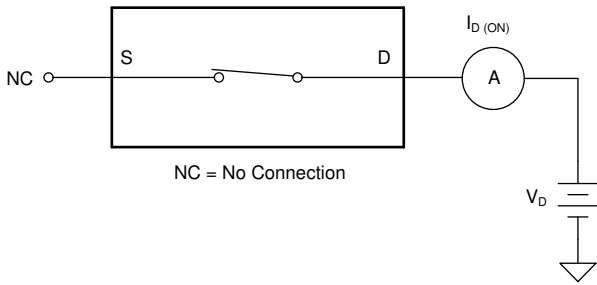
On-leakage current is defined as the leakage current that flows into or out of the drain pin when the switch is in the on state. The source pin is left floating during the measurement.  shows the circuit used for measuring the on-leakage current, denoted by  $I_{D(ON)}$ .

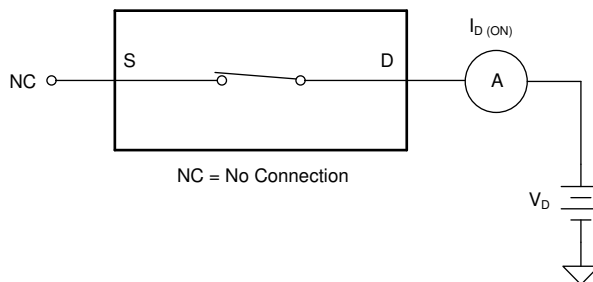

 **8-3. On-Leakage Measurement Setup**

### 8.1.4 Turn-On and Turn-Off Time

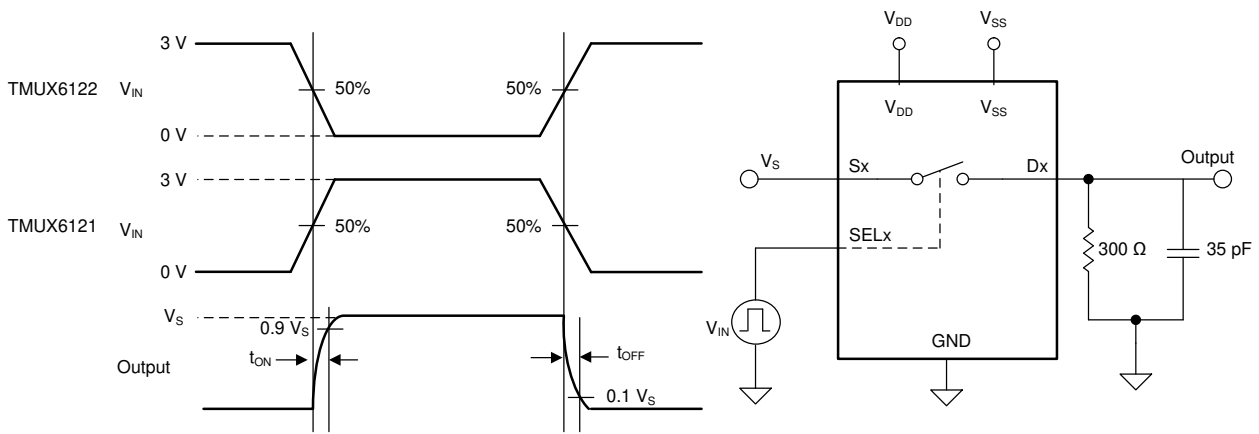
Turn-on time is defined as the time taken by the output of the TMUX6121, TMUX6122, and TMUX6123 to rise to a 90% final value after the SELx signal has risen (for NO switches) or fallen (for NC switches) to a 50% final value.  shows the setup used to measure turn-on time. Turn-on time is denoted by the symbol  $t_{ON}$ .

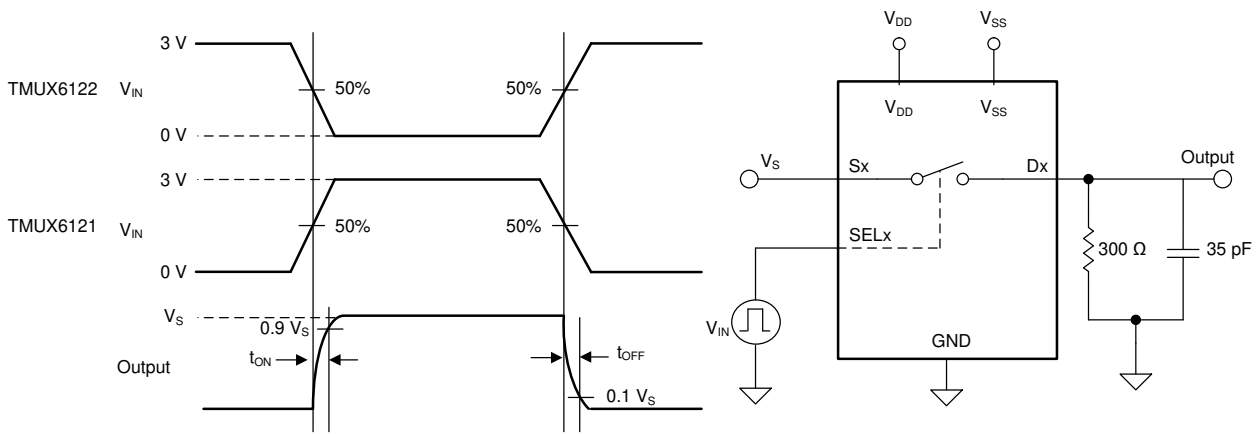
Turn off time is defined as the time taken by the output of the TMUX6121, TMUX6122, and TMUX6123 to fall to a 10% initial value after the SELx signal has fallen (for NO switches) or risen (for NC switches) to a 50% initial value.  shows the setup used to measure turn-off time. Turn-off time is denoted by the symbol  $t_{OFF}$ .

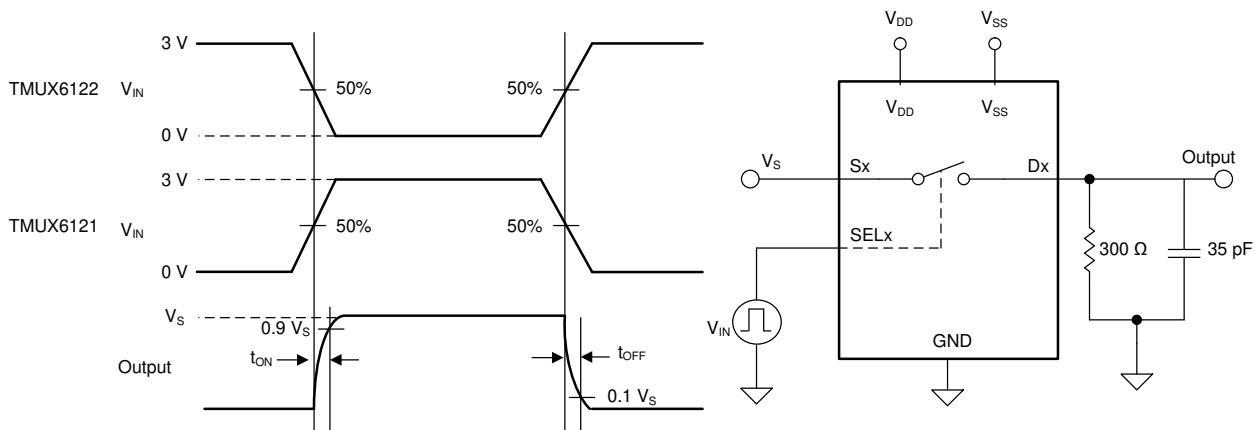

 **8-4. Transition-Time Measurement Setup**

### 8.1.5 Break-Before-Make Delay

The break-before-make delay is a safety feature of the TMUX6123 switch. The TMUX6123's ON switches first break the connection before the OFF switches make connection. The time delay between the break and the make is known as break-before-make delay. [Figure 8-5](#) shows the setup used to measure break-before-make delay, denoted by the symbol  $t_{BBM}$ .

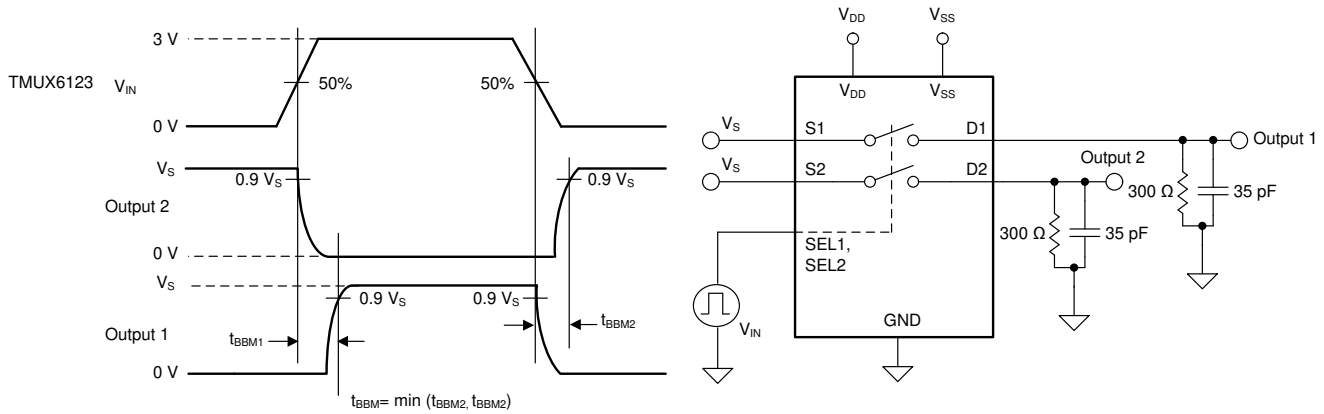

**Figure 8-5. Break-Before-Make Delay Measurement Setup**

### 8.1.6 Charge Injection

The TMUX6121, TMUX6122, and TMUX6123 have a simple transmission-gate topology. Any mismatch in capacitance between the NMOS and PMOS transistors results in a charge injected into the drain or source during the falling or rising edge of the gate signal. The amount of charge injected into the source or drain of the device is known as charge injection, and is denoted by the symbol  $Q_{INJ}$ . [Figure 8-6](#) shows the setup used to measure charge injection.

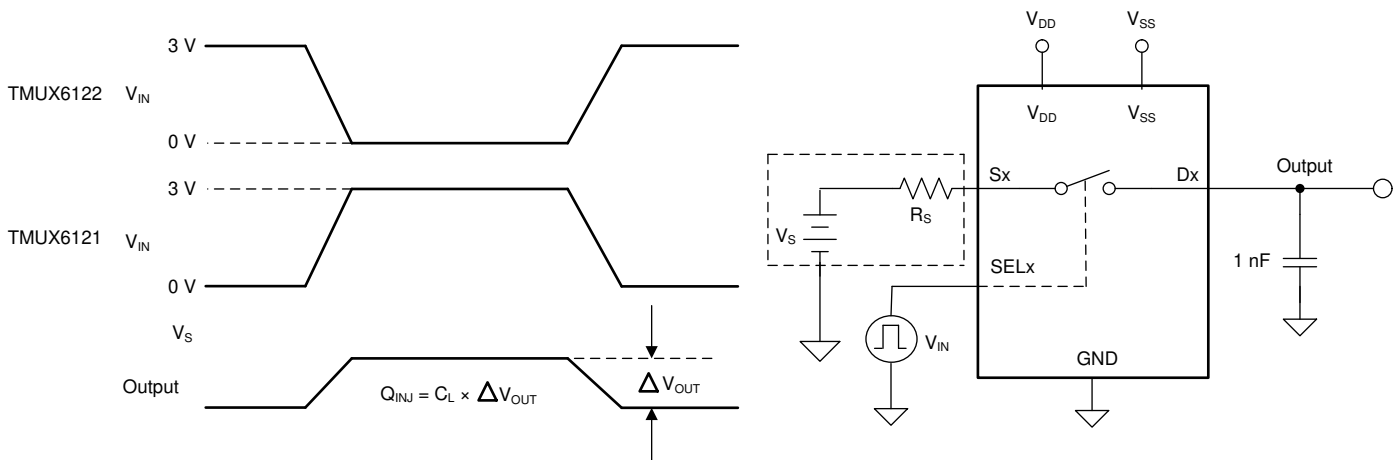

**Figure 8-6. Charge-Injection Measurement Setup**

### 8.1.7 Off Isolation

Off isolation is defined as the voltage at the drain pin ( $D_x$ ) of the TMUX6121, TMUX6122, and TMUX6123 when a  $1-V_{RMS}$  signal is applied to the source pin ( $S_x$ ) of an OFF switch. [Figure 8-7](#) shows the setup used to measure off isolation. Use [Equation 2](#) to compute off isolation.

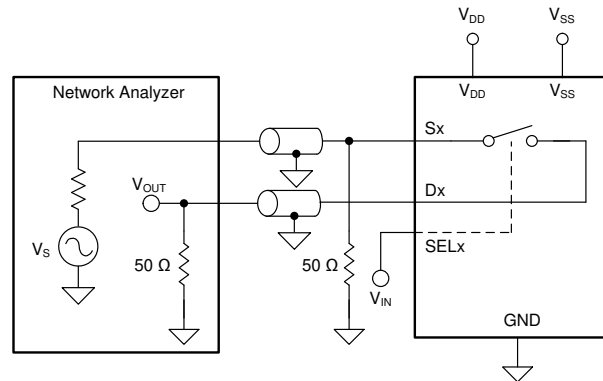

**8-7. Off Isolation Measurement Setup**

$$\text{Off Isolation} = 20 \cdot \text{Log} \left( \frac{V_{\text{OUT}}}{V_{\text{S}}} \right) \quad (2)$$

### 8.1.8 Channel-to-Channel Crosstalk

Channel-to-channel crosstalk is defined as the voltage at the source pin (Sx) of an off-channel, when a 1- $V_{\text{RMS}}$  signal is applied at the source pin (Sx) of an on-channel. [8-8](#) shows the setup used to measure, and [3](#) is the equation used to compute, channel-to-channel crosstalk.

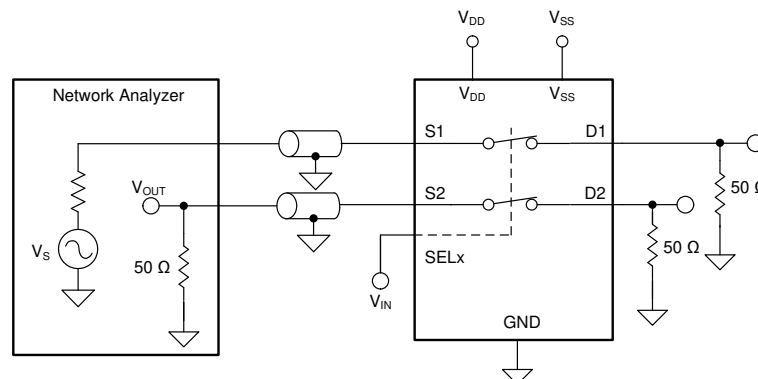

**8-8. Channel-to-Channel Crosstalk Measurement Setup**

$$\text{Channel-to-Channel Crosstalk} = 20 \cdot \text{Log} \left( \frac{V_{\text{OUT}}}{V_{\text{S}}} \right) \quad (3)$$

### 8.1.9 Bandwidth

Bandwidth is defined as the range of frequencies that are attenuated by < 3 dB when the input is applied to the source pin (Sx) of an on-channel, and the output is measured at the drain pin (D) of the TMUX6121, TMUX6122, and TMUX6123. [8-9](#) shows the setup used to measure bandwidth of the switch. Use [4](#) to compute the attenuation.



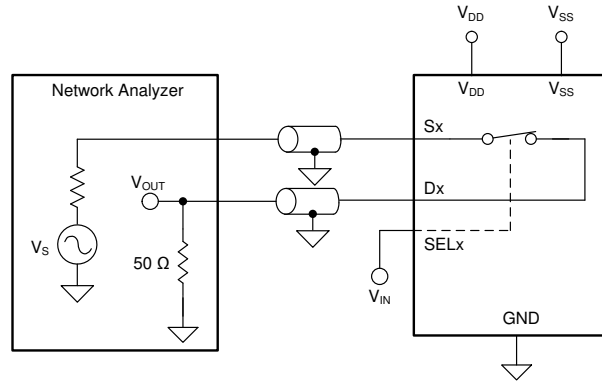

**8-9. Bandwidth Measurement Setup**

$$\text{Attenuation} = 20 \cdot \text{Log} \left( \frac{V_2}{V_1} \right) \tag{4}$$

### 8.1.10 THD + Noise

The total harmonic distortion (THD) of a signal is a measurement of the harmonic distortion, and is defined as the ratio of the sum of the powers of all harmonic components to the power of the fundamental frequency at the mux output. The on-resistance of the TMUX6121, TMUX6122, and TMUX6123 varies with the amplitude of the input signal and results in distortion when the drain pin is connected to a low-impedance load. Total harmonic distortion plus noise is denoted as THD+N. 8-10 shows the setup used to measure THD+N of the TMUX6121, TMUX6122, and TMUX6123.

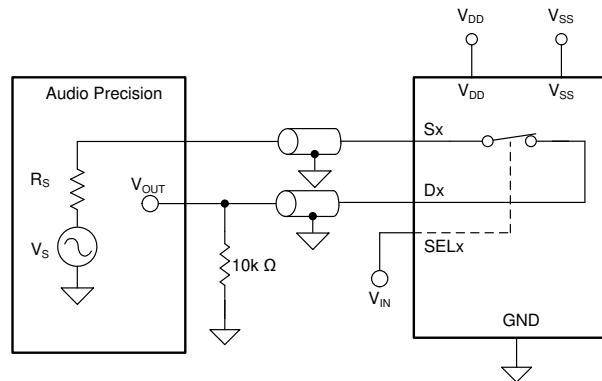

**8-10. THD+N Measurement Setup**

### 8.1.11 AC Power Supply Rejection Ratio (AC PSRR)

AC PSRR measures the ability of a device to prevent noise and spurious signals that appear on the supply voltage pin from coupling to the output of the switch. The DC voltage on the device supply is modulated by a sine wave of 620 mVPP. The ratio of the amplitude of signal on the output to the amplitude of the modulated signal is the AC PSRR. 8-11 shows the setup used to measure ACPSRR of the TMUX6121, TMUX6122, and TMUX6123.

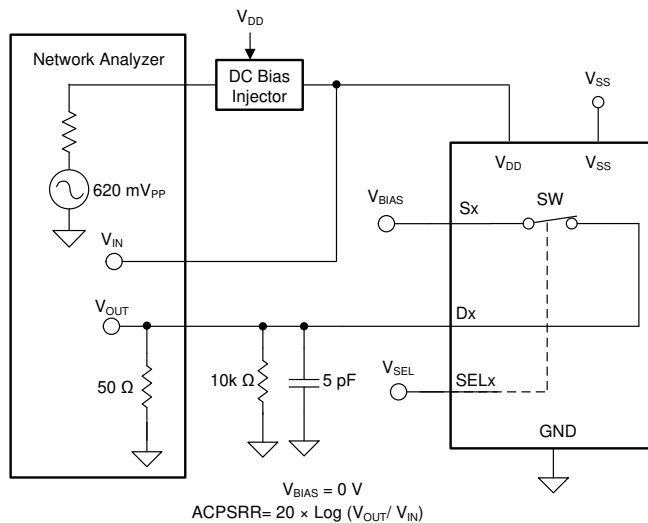

**8-11. AC PSRR Measurement Setup**

セクション 8.2 provides a top-level block diagram of the TMUX6121, TMUX6122, and TMUX6123. The devices are 2-channel, single-ended, analog switches. Each channel is turned on or turned off based on the state of the address lines and enable pin.

## 8.2 Functional Block Diagram

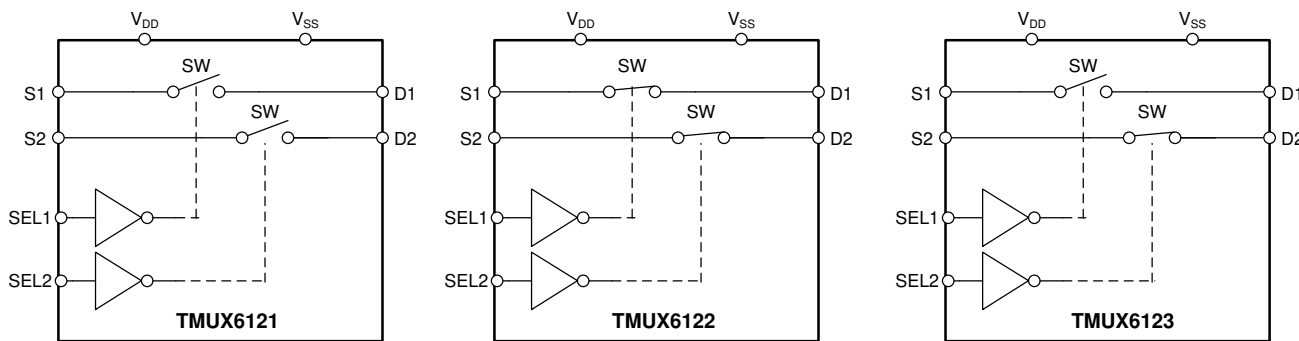

ALL SWITCHES SHOWN FOR A LOGIC 0 INPUT

## 8.3 Feature Description

### 8.3.1 Ultralow Leakage Current

The TMUX6121, TMUX6122, and TMUX6123 provide extremely low on- and off-leakage currents. The devices are capable of switching signals from high source-impedance inputs into a high input-impedance op amp with minimal offset error because of the ultralow leakage currents. 8-12 shows typical leakage currents of the devices versus temperature.

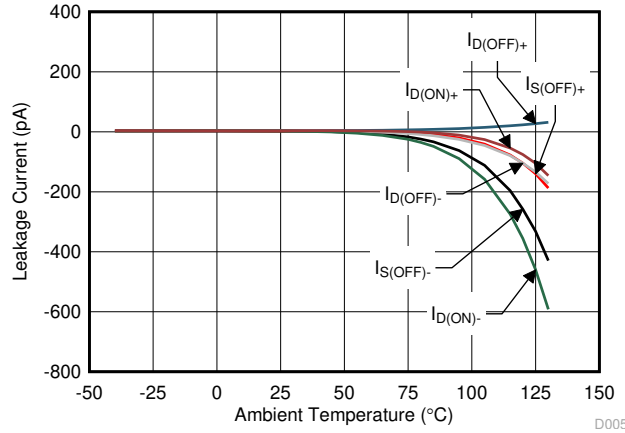

**8-12. Leakage Current vs Temperature**

### 8.3.2 Ultralow Charge Injection

The TMUX6121 is implemented with simple transmission gate topology, as shown in 8-13. Any mismatch in the stray capacitance associated with the NMOS and PMOS causes an output level change whenever the switch is opened or closed.

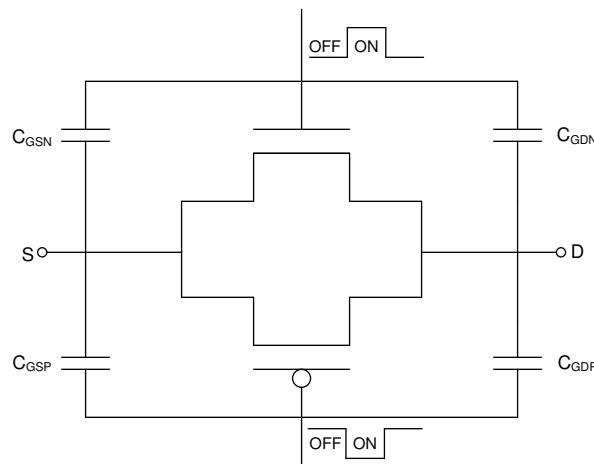

**8-13. Transmission Gate Topology**

The devices utilize special charge-injection cancellation circuitry that reduces the source (Sx)-to-drain (Dx) charge injection to as low as 0.51 pC at  $V_S = 0\text{ V}$ , as shown in 8-14.

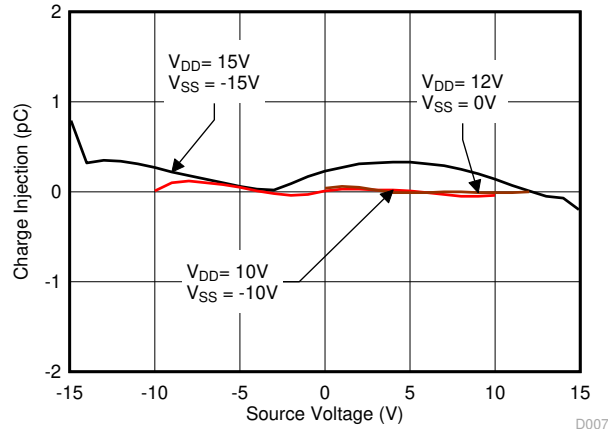

8-14. Source-to-Drain Charge Injection vs Source or Drain Voltage

### 8.3.3 Bidirectional and Rail-to-Rail Operation

The TMUX6121, TMUX6122, and TMUX6123 conduct equally well from source (Sx) to drain (Dx) or from drain (Dx) to source (Sx). Each channel of the switches has very similar characteristics in both directions. The input signal to the devices swings from  $V_{SS}$  to  $V_{DD}$  without any significant degradation in performance. The on resistance of these devices varies with input signal.

### 8.4 Device Functional Modes

Each channel of the TMUX6121, TMUX6122, and TMUX6123 is turned on or turned off based on the state of its corresponding SELx pin. The SELx pins are weakly pulled-down through an internal 6 M $\Omega$  resistor, allowing the switches to stay in a determined state when power is applied to the devices. The SELx pins can be connected to  $V_{DD}$ .

## 9 Application and Implementation

### 注

以下のアプリケーション情報は、TI の製品仕様に含まれるものではなく、TI ではその正確性または完全性を保証いたしません。個々の目的に対する製品の適合性については、お客様の責任で判断していただくこととなります。お客様は自身の設計実装を検証しテストすることで、システムの機能を確認する必要があります。

### 9.1 Application Information

The TMUX6121, TMUX6122, and TMUX6123 offer outstanding input/output leakage currents and ultralow charge injection. These devices operate up to 33 (dual supply) or 16.5 V (single supply), and offer true rail-to-rail input and output. The on-capacitance of the TMUX6121, TMUX6122, and TMUX6123 is low. These features makes the TMUX6121, TMUX6122, and TMUX6123 a family of precision, robust, high-performance analog multiplexer for high-voltage, industrial applications.

### 9.2 Typical Application

One useful application to take advantage of TMUX6121, TMUX6122, and TMUX6123's precision performance is the sample and hold circuit. A sample and hold circuit can be useful for an analog to digital converter (ADC) to sample a varying input voltage with improved reliability and stability. It can also be used to store the output samples from a single digital-to-analog converter (DAC) in a multi-output application. A simple sample and hold circuit can be realized using an analog switch like one of the TMUX6121, TMUX6122, and TMUX6123 analog switches.



図 9-1. A Sample and Hold Circuit Realized Using the TMUX611x Analog Switch

### 9.2.1 Design Requirements

The purpose of this precision design is to implement an optimized 2-output sample and hold circuit using a 4-channel SPST switch. The sample and hold circuit needs to be capable of supporting high voltage output swing up to  $\pm 15$  V with minimized pedestal error and fast settling time. The overall system block diagram is shown in [Figure 9-1](#).

### 9.2.2 Detailed Design Procedure

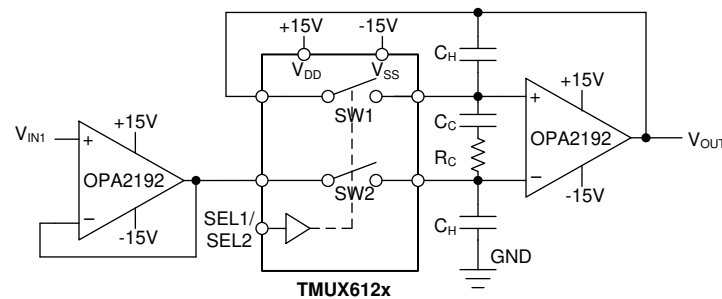
The TMUX6121, TMUX6122, or TMUX6123 switch is used in conjunction with the voltage holding capacitors ( $C_H$ ) to implement the sample and hold circuit. The basic operation is:

1. When the switch SW2 is closed, it samples the input voltage and charges the holding capacitors ( $C_H$ ) to the input voltages values.
2. When the switch SW2 is open, the holding capacitors ( $C_H$ ) holds its previous value, maintaining stable voltage at the amplifier output ( $V_{OUT}$ )

Ideally, the switch delivers only the input signals to the holding capacitors. However, when the switch gets toggled, some amount of charge also gets transferred to the switch output in the form of charge injection, resulting slight sampling error. The TMUX6121, TMUX6122, and TMUX6123 switches have excellent charge injection performance of only 0.51 pC, making them ideal choices for this implementation to minimize sampling error. Due to switch and capacitor leakage current, the voltage on the hold capacitors droops with time. The TMUX6121, TMUX6122, and TMUX6123 minimize the droops due to its ultra-low leakage performance. At 25°C, the TMUX6111, TMUX6112, and TMUX6113 have extremely tiny leakage current at 0.5 pA typical and 20 pA maximum. The TMUX6121, TMUX6122, and TMUX6123 devices also support high voltage capability. The devices support up to  $\pm 16.5$  V dual supply operation, making it an ideal solution in this high voltage sample and hold application.

A second switch SW1 is also included to operate in parallel with SW2 to reduce pedestal error during switch toggling. Because both switches are driven at the same potential, they act as common-mode signal to the op-amp, thereby minimizing the charge injection effects caused by the switch toggling action. Compensation network consisting of  $R_C$  and  $CC$  is also added to further reduce the pedestal error, while reducing the hold-time glitch and improving the settling time of the circuit.

### 9.2.3 Application Curve

TMUX6121, TMUX6122, and TMUX6123 have excellent charge injection performance of only 0.51 pC (typical), making them ideal choices to minimize sampling error for the sample and hold application. [Figure 9-2](#) shows the plot for the charge injection versus source input voltage for TMUX6121, TMUX6122, and TMUX6123.

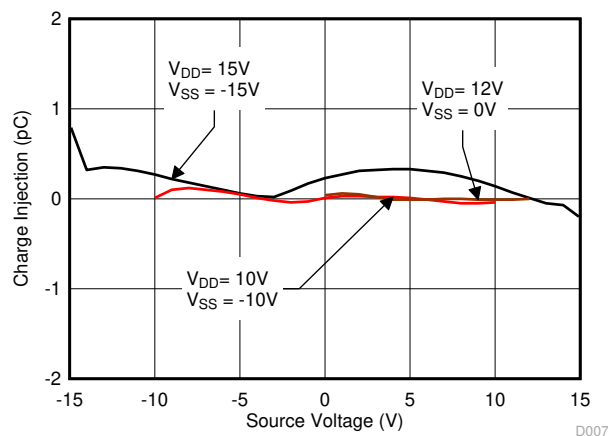
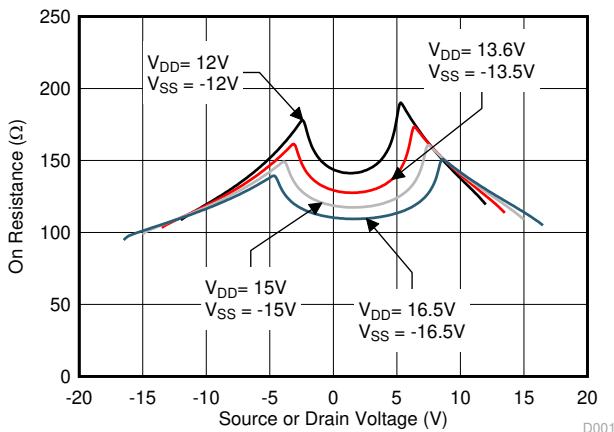

**Figure 9-2. Charge Injection vs. Source Voltage for TMUX6121, TMUX6122 and TMUX6123**

## 10 Power Supply Recommendations

The TMUX6121, TMUX6122, and TMUX6123 operate across a wide supply range of  $\pm 5$  V to  $\pm 16.5$  V (10 V to 16.5 V in single-supply mode). They also perform well with asymmetrical supplies such as  $V_{DD} = 12$  V and  $V_{SS} = -5$  V. For improved supply noise immunity, use a supply decoupling capacitor ranging from 0.1  $\mu$ F to 10  $\mu$ F at both the  $V_{DD}$  and  $V_{SS}$  pins to ground. Always ensure the ground (GND) connection is established before supplies are ramped. As a best practice, it is recommended to ramp  $V_{SS}$  first before  $V_{DD}$  in dual or asymmetrical supply applications.

The on-resistance of the TMUX6121, TMUX6122, and TMUX6123 varies with supply voltage, as shown in [10-1](#)



**10-1. On-Resistance Variation With Supply and Input Voltage**

## 11 Layout

### 11.1 Layout Guidelines

[11-1](#) shows an example of a PCB layout with the TMUX6121, TMUX6122, and TMUX6123.

Some key considerations are:

1. Decouple the  $V_{DD}$  and  $V_{SS}$  pins with a 0.1- $\mu$ F capacitor, placed as close to the pin as possible. Make sure that the capacitor voltage rating is sufficient for the  $V_{DD}$  and  $V_{SS}$  supplies.
2. Keep the input lines as short as possible.
3. Use a solid ground plane to help distribute heat and reduce electromagnetic interference (EMI) noise pickup.
4. Do not run sensitive analog traces in parallel with digital traces. Avoid crossing digital and analog traces if possible, and only make perpendicular crossings when necessary.

### 11.2 Layout Example

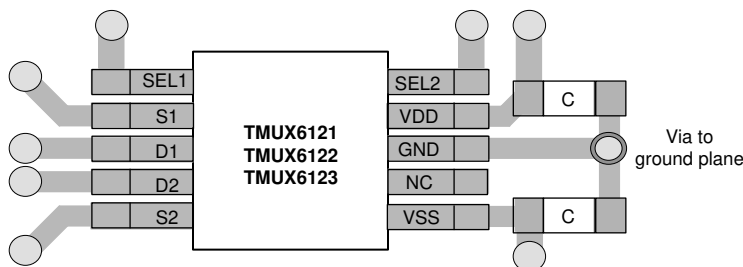

**11-1. TMUX6121 Layout Example**

## 12 Device and Documentation Support

### 12.1 Documentation Support

#### 12.1.1 Related Documentation

For related documentation, see the following:

- Texas Instruments, [OPAx192 36-V, Precision, Rail-to-Rail Input/Output, Low Offset Voltage, Low Input Bias Current Op Amp with e-trim™](#)

#### 12.2 Receiving Notification of Documentation Updates

To receive notification of documentation updates, navigate to the device product folder on [ti.com](#). Click on [Subscribe to updates](#) to register and receive a weekly digest of any product information that has changed. For change details, review the revision history included in any revised document.

### 12.3 サポート・リソース

TI E2E™ サポート・フォーラムは、エンジニアが検証済みの回答と設計に関するヒントをエキスパートから迅速かつ直接得ることができる場所です。既存の回答を検索したり、独自の質問をしたりすることで、設計に必要な支援を迅速に得ることができます。

リンクされているコンテンツは、該当する貢献者により、現状のまま提供されるものです。これらは TI の仕様を構成するものではなく、必ずしも TI の見解を反映したものではありません。TI の [使用条件](#) を参照してください。

#### 12.4 Trademarks

TI E2E™ is a trademark of Texas Instruments.

すべての商標は、それぞれの所有者に帰属します。

#### 12.5 Electrostatic Discharge Caution



This integrated circuit can be damaged by ESD. Texas Instruments recommends that all integrated circuits be handled with appropriate precautions. Failure to observe proper handling and installation procedures can cause damage.

ESD damage can range from subtle performance degradation to complete device failure. Precision integrated circuits may be more susceptible to damage because very small parametric changes could cause the device not to meet its published specifications.

#### 12.6 Glossary

[TI Glossary](#) This glossary lists and explains terms, acronyms, and definitions.

## 13 Mechanical, Packaging, and Orderable Information

The following pages include mechanical, packaging, and orderable information. This information is the most current data available for the designated devices. This data is subject to change without notice and revision of this document. For browser-based versions of this data sheet, refer to the left-hand navigation.



**PACKAGING INFORMATION**

Orderable part number	Status (1)	Material type (2)	Package   Pins	Package qty   Carrier	RoHS (3)	Lead finish/ Ball material (4)	MSL rating/ Peak reflow (5)	Op temp (°C)	Part marking (6)
<a href="#">TMUX6121DGSR</a>	Active	Production	VSSOP (DGS)   10	2500   LARGE T&R	Yes	NIPDAUAG   SN	Level-2-260C-1 YEAR	-40 to 125	1Q16
TMUX6121DGSR.B	Active	Production	VSSOP (DGS)   10	2500   LARGE T&R	Yes	SN	Level-2-260C-1 YEAR	-40 to 125	1Q16
<a href="#">TMUX6122DGSR</a>	Active	Production	VSSOP (DGS)   10	2500   LARGE T&R	Yes	NIPDAUAG   SN	Level-2-260C-1 YEAR	-40 to 125	1Q26
TMUX6122DGSR.B	Active	Production	VSSOP (DGS)   10	2500   LARGE T&R	Yes	SN	Level-2-260C-1 YEAR	-40 to 125	1Q26
<a href="#">TMUX6123DGSR</a>	Active	Production	VSSOP (DGS)   10	2500   LARGE T&R	Yes	NIPDAUAG   SN	Level-2-260C-1 YEAR	-40 to 125	1Q36
TMUX6123DGSR.B	Active	Production	VSSOP (DGS)   10	2500   LARGE T&R	Yes	SN	Level-2-260C-1 YEAR	-40 to 125	1Q36

(1) **Status:** For more details on status, see our [product life cycle](#).

(2) **Material type:** When designated, preproduction parts are prototypes/experimental devices, and are not yet approved or released for full production. Testing and final process, including without limitation quality assurance, reliability performance testing, and/or process qualification, may not yet be complete, and this item is subject to further changes or possible discontinuation. If available for ordering, purchases will be subject to an additional waiver at checkout, and are intended for early internal evaluation purposes only. These items are sold without warranties of any kind.

(3) **RoHS values:** Yes, No, RoHS Exempt. See the [TI RoHS Statement](#) for additional information and value definition.

(4) **Lead finish/Ball material:** Parts may have multiple material finish options. Finish options are separated by a vertical ruled line. Lead finish/Ball material values may wrap to two lines if the finish value exceeds the maximum column width.

(5) **MSL rating/Peak reflow:** The moisture sensitivity level ratings and peak solder (reflow) temperatures. In the event that a part has multiple moisture sensitivity ratings, only the lowest level per JEDEC standards is shown. Refer to the shipping label for the actual reflow temperature that will be used to mount the part to the printed circuit board.

(6) **Part marking:** There may be an additional marking, which relates to the logo, the lot trace code information, or the environmental category of the part.

Multiple part markings will be inside parentheses. Only one part marking contained in parentheses and separated by a "~" will appear on a part. If a line is indented then it is a continuation of the previous line and the two combined represent the entire part marking for that device.

**Important Information and Disclaimer:** The information provided on this page represents TI's knowledge and belief as of the date that it is provided. TI bases its knowledge and belief on information provided by third parties, and makes no representation or warranty as to the accuracy of such information. Efforts are underway to better integrate information from third parties. TI has taken and continues to take reasonable steps to provide representative and accurate information but may not have conducted destructive testing or chemical analysis on incoming materials and chemicals. TI and TI suppliers consider certain information to be proprietary, and thus CAS numbers and other limited information may not be available for release.

In no event shall TI's liability arising out of such information exceed the total purchase price of the TI part(s) at issue in this document sold by TI to Customer on an annual basis.



**TAPE AND REEL INFORMATION**

**QUADRANT ASSIGNMENTS FOR PIN 1 ORIENTATION IN TAPE**

\*All dimensions are nominal

Device	Package Type	Package Drawing	Pins	SPQ	Reel Diameter (mm)	Reel Width W1 (mm)	A0 (mm)	B0 (mm)	K0 (mm)	P1 (mm)	W (mm)	Pin1 Quadrant
TMUX6121DGSR	VSSOP	DGS	10	2500	330.0	12.4	5.25	3.35	1.25	8.0	12.0	Q1
TMUX6122DGSR	VSSOP	DGS	10	2500	330.0	12.4	5.25	3.35	1.25	8.0	12.0	Q1
TMUX6123DGSR	VSSOP	DGS	10	2500	330.0	12.4	5.25	3.35	1.25	8.0	12.0	Q1
TMUX6123DGSR	VSSOP	DGS	10	2500	330.0	12.4	5.3	3.4	1.4	8.0	12.0	Q1

**TAPE AND REEL BOX DIMENSIONS**

\*All dimensions are nominal

Device	Package Type	Package Drawing	Pins	SPQ	Length (mm)	Width (mm)	Height (mm)
TMUX6121DGSR	VSSOP	DGS	10	2500	366.0	364.0	50.0
TMUX6122DGSR	VSSOP	DGS	10	2500	366.0	364.0	50.0
TMUX6123DGSR	VSSOP	DGS	10	2500	366.0	364.0	50.0
TMUX6123DGSR	VSSOP	DGS	10	2500	366.0	364.0	50.0

# DGS0010A



# PACKAGE OUTLINE

## VSSOP - 1.1 mm max height

SMALL OUTLINE PACKAGE



4221984/A 05/2015

### NOTES:

1. All linear dimensions are in millimeters. Any dimensions in parenthesis are for reference only. Dimensioning and tolerancing per ASME Y14.5M.
2. This drawing is subject to change without notice.
3. This dimension does not include mold flash, protrusions, or gate burrs. Mold flash, protrusions, or gate burrs shall not exceed 0.15 mm per side.
4. This dimension does not include interlead flash. Interlead flash shall not exceed 0.25 mm per side.
5. Reference JEDEC registration MO-187, variation BA.

# EXAMPLE BOARD LAYOUT

DGS0010A

VSSOP - 1.1 mm max height

SMALL OUTLINE PACKAGE



LAND PATTERN EXAMPLE  
SCALE:10X

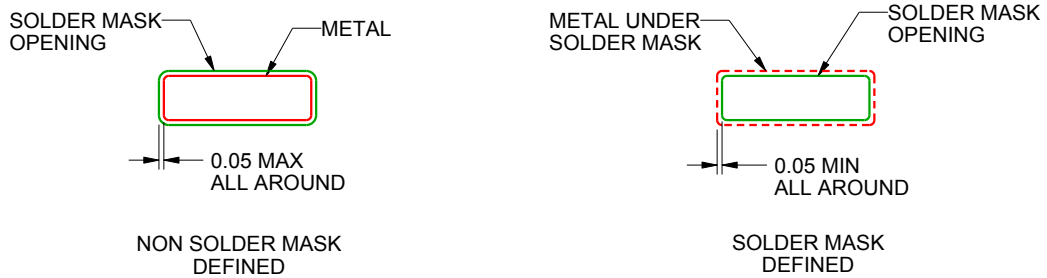

SOLDER MASK DETAILS  
NOT TO SCALE

4221984/A 05/2015

NOTES: (continued)

6. Publication IPC-7351 may have alternate designs.
7. Solder mask tolerances between and around signal pads can vary based on board fabrication site.

# EXAMPLE STENCIL DESIGN

DGS0010A

VSSOP - 1.1 mm max height

SMALL OUTLINE PACKAGE



SOLDER PASTE EXAMPLE  
BASED ON 0.125 mm THICK STENCIL  
SCALE:10X

4221984/A 05/2015

NOTES: (continued)

8. Laser cutting apertures with trapezoidal walls and rounded corners may offer better paste release. IPC-7525 may have alternate design recommendations.
9. Board assembly site may have different recommendations for stencil design.

## 重要なお知らせと免責事項

TI は、技術データと信頼性データ(データシートを含みます)、設計リソース(リファレンス デザインを含みます)、アプリケーションや設計に関する各種アドバイス、Web ツール、安全性情報、その他のリソースを、欠陥が存在する可能性のある「現状のまま」提供しており、商品性および特定目的に対する適合性の黙示保証、第三者の知的財産権の非侵害保証を含むいかなる保証も、明示的または黙示的にかかわらず拒否します。

これらのリソースは、TI 製品を使用する設計の経験を積んだ開発者への提供を意図したものです。(1) お客様のアプリケーションに適した TI 製品の選定、(2) お客様のアプリケーションの設計、検証、試験、(3) お客様のアプリケーションに該当する各種規格や、その他のあらゆる安全性、セキュリティ、規制、または他の要件への確実な適合に関する責任を、お客様のみが単独で負うものとし、

上記の各種リソースは、予告なく変更される可能性があります。これらのリソースは、リソースで説明されている TI 製品を使用するアプリケーションの開発の目的でのみ、TI はその使用をお客様に許諾します。これらのリソースに関して、他の目的で複製することや掲載することは禁止されています。TI や第三者の知的財産権のライセンスが付与されている訳ではありません。お客様は、これらのリソースを自身で使用した結果発生するあらゆる申し立て、損害、費用、損失、責任について、TI およびその代理人を完全に補償するものとし、TI は一切の責任を拒否します。

TI の製品は、[TI の販売条件](#)、[TI の総合的な品質ガイドライン](#)、[ti.com](#) または TI 製品などに関連して提供される他の適用条件に従い提供されます。TI がこれらのリソースを提供することは、適用される TI の保証または他の保証の放棄の拡大や変更を意味するものではありません。TI がカスタム、またはカスタマー仕様として明示的に指定していない限り、TI の製品は標準的なカタログに掲載される汎用機器です。

お客様がいかなる追加条項または代替条項を提案する場合も、TI はそれらに異議を唱え、拒否します。

Copyright © 2025, Texas Instruments Incorporated

最終更新日：2025 年 10 月