

TMUX7236 44V、低 RON、2 : 1 (SPDT)、2 チャンネル高精度スイッチ、ラッチアップ アップフリー、1.8V ロジック対応

1 特長

- ラッチアップ・フリー
- デュアル電源電圧範囲: $\pm 4.5V \sim \pm 22V$
- シングル電源電圧範囲: $4.5V \sim 44V$
- 低オン抵抗: 2Ω
- 大電流対応: 330mA (最大値) (WQFN)
- $-40^\circ C \sim +125^\circ C$ の動作温度範囲
- 1.8V ロジック互換
- ロジック・ピンにプルダウン抵抗を内蔵
- フェイルセーフ・ロジック
- レール・ツー・レール動作
- 双方向動作

2 アプリケーション

- ガス・メータ
- 流量トランスミッタ
- ファクトリ・オートメーションと産業用制御
- プログラマブル・ロジック・コントローラ (PLC)
- アナログ入力モジュール
- 半導体試験装置
- データ・アキュイジション・システム
- 超音波スキャナ
- 光学ネットワーク機器
- 光学テスト機器
- リモート無線ユニット
- 有線ネットワーク
- メディカル・モニタと診断

3 概要

TMUX7236 は、2 チャンネル、2:1 構成、ラッチアップ・フリーの相補型金属酸化膜半導体 (CMOS) スイッチです。本デバイスはデュアル電源 ($\pm 5V \sim \pm 22V$)、シングル電源 ($5V \sim 44V$)、または非対称電源 ($V_{DD} = 12V$ 、 $V_{SS} = -5V$ など) で適切に動作します。TMUX7236 は、ソース (Sx) およびドレイン (D) ピンで、 V_{SS} から V_{DD} までの範囲の双方向アナログおよびデジタル信号をサポートします。

すべてのロジック制御入力は、 $1.8V \sim V_{DD}$ のロジック・レベルをサポートしており、有効な電源電圧範囲で動作している場合、TTL ロジックと CMOS ロジックの両方の互換性を確保できます。フェイルセーフ・ロジック回路によって、電源ピンよりも先に制御ピンに電圧が印加されるため、デバイスへの損傷の可能性が避けられます。

TMUX72xx ファミリは、ラッチアップ耐性を備えており、一般的に過電圧イベントによって発生するデバイス内の寄生構造間の好ましくない大電流イベントを防止できます。ラッチアップ状態は通常、電源レールがターンオフされるまで継続するため、デバイスの障害の原因になる場合があります。このラッチアップ・フリーという特長により、TMUX72xx スイッチおよびマルチプレクサ・ファミリは過酷な環境でも使用できます。

パッケージ情報

部品番号	パッケージ ⁽¹⁾	パッケージサイズ ⁽²⁾
TMUX7236	RUM (WQFN, 16)	4mm × 4mm
	PW (TSSOP, 16)	5mm × 6.4mm

(1) 詳細については、[セクション 11](#) を参照してください。

(2) パッケージサイズ (長さ×幅) は公称値であり、該当する場合はピンも含まれます。

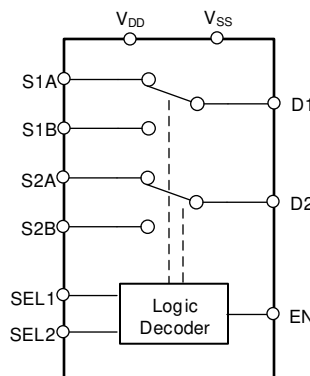

ブロック図



Table of Contents

1 特長	1	6.8 Propagation Delay.....	22
2 アプリケーション	1	6.9 Charge Injection.....	23
3 概要	1	6.10 Off Isolation.....	23
4 Pin Configuration and Functions	3	6.11 Crosstalk.....	24
5 Specifications	4	6.12 Bandwidth.....	24
5.1 Absolute Maximum Ratings.....	4	6.13 THD + Noise.....	25
5.2 ESD Ratings.....	4	6.14 Power Supply Rejection Ratio (PSRR).....	25
5.3 Thermal Information.....	5	7 Detailed Description	26
5.4 Recommended Operating Conditions.....	5	7.1 Functional Block Diagram.....	26
5.5 Source or Drain Continuous Current.....	5	7.2 Feature Description.....	26
5.6 ±15 V Dual Supply: Electrical Characteristics	6	7.3 Device Functional Modes.....	28
5.7 ±15 V Dual Supply: Switching Characteristics	7	7.4 Truth Tables.....	28
5.8 ±20 V Dual Supply: Electrical Characteristics.....	8	8 Application and Implementation	29
5.9 ±20 V Dual Supply: Switching Characteristics.....	9	8.1 Application Information.....	29
5.10 44 V Single Supply: Electrical Characteristics	10	8.2 Typical Application.....	29
5.11 44 V Single Supply: Switching Characteristics	11	8.3 Power Supply Recommendations.....	31
5.12 12 V Single Supply: Electrical Characteristics	12	8.4 Layout.....	31
5.13 12 V Single Supply: Switching Characteristics	13	9 Device and Documentation Support	33
5.14 Typical Characteristics.....	14	9.1 Documentation Support.....	33
6 Parameter Measurement Information	19	9.2 ドキュメントの更新通知を受け取る方法.....	33
6.1 On-Resistance.....	19	9.3 サポート・リソース.....	33
6.2 Off-Leakage Current.....	19	9.4 Trademarks.....	33
6.3 On-Leakage Current.....	20	9.5 用語集.....	33
6.4 Transition Time.....	20	9.6 静電気放電に関する注意事項.....	33
6.5 $t_{ON(EN)}$ and $t_{OFF(EN)}$	21	10 Revision History	33
6.6 Break-Before-Make.....	21	11 Mechanical, Packaging, and Orderable Information	34
6.7 $t_{ON(VDD)}$ Time.....	22		

4 Pin Configuration and Functions



図 4-1. RUM Package, 16-Pin WQFN (Top View)



図 4-2. PW Package, 16-Pin TSSOP (Top View)

表 4-1. Pin Functions

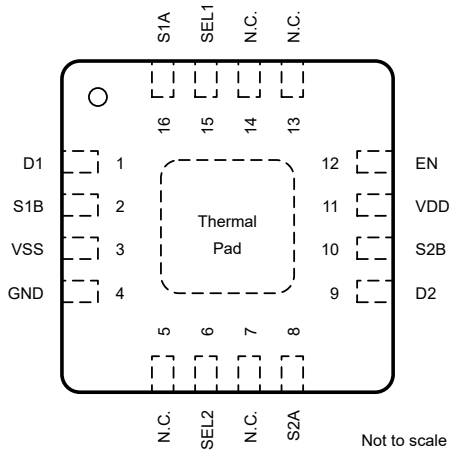
NAME	PIN		TYPE ⁽¹⁾	DESCRIPTION
	TSSOP	WQFN		
D1	3	1	I/O	Drain pin. Can be an input or output.
D2	11	9	I/O	Drain pin. Can be an input or output.
GND	6	4	P	Ground (0 V) reference
NC	7, 8, 15, 16	5, 7, 13, 14	—	No internal connection. Can be shorted to GND or left floating.
S1A	2	16	I/O	Source pin 1A. Can be an input or output.
S1B	4	2	I/O	Source pin 1B. Can be an input or output.
S2A	10	8	I/O	Source pin 2A. Can be an input or output.
S2B	12	10	I/O	Source pin 2B. Can be an input or output.
EN	14	12	I	Active high logic enable, has internal pull-up resistor. When this pin is low, all switches are turned off. When this pin is high, the SEL logic input determine which switch is turned on.
SEL1	1	15	I	Logic control input, has internal pull-down resistor. Controls the switch connection as shown in セクション 7.4 .
SEL2	9	6	I	Logic control input, has internal pull-down resistor. Controls the switch connection as shown in セクション 7.4 .
V _{DD}	13	11	P	Positive power supply. This pin is the most positive power-supply potential. For reliable operation, connect a decoupling capacitor ranging from 0.1 μF to 10 μF between V _{DD} and GND.
V _{SS}	5	3	P	Negative power supply. This pin is the most negative power-supply potential. In single-supply applications, this pin can be connected to ground. For reliable operation, connect a decoupling capacitor ranging from 0.1 μF to 10 μF between V _{SS} and GND.
Thermal Pad			—	The thermal pad is not connected internally. There is no requirement to electrically connect this pad. If connected, however, it is recommended that the pad be left floating or tied to GND.

(1) I = input, O = output, P = power

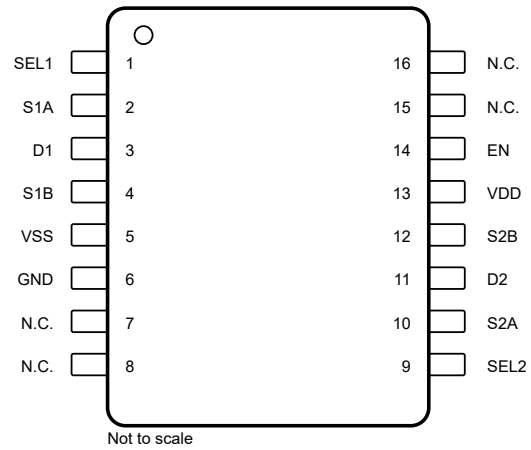
5 Specifications

5.1 Absolute Maximum Ratings

over operating free-air temperature range (unless otherwise noted)⁽¹⁾ ⁽²⁾

		MIN	MAX	UNIT
$V_{DD} - V_{SS}$	Supply voltage		48	V
V_{DD}		-0.5	48	V
V_{SS}		-48	0.5	V
V_{SEL} or V_{EN}	Logic control input pin voltage (SELx)	-0.5	48	V
I_{SEL} or I_{EN}	Logic control input pin current (SELx)	-30	30	mA
V_S or V_D	Source or drain voltage (Sx, Dx)	$V_{SS}-0.5$	$V_{DD}+0.5$	V
I_{IK}	Diode clamp current ⁽³⁾	-30	30	mA
I_S or I_D (CONT)	Source or drain continuous current (Sx, Dx)		$I_{DC} + 10\%$ ⁽⁴⁾	mA
T_A	Ambient temperature	-55	150	°C
T_{stg}	Storage temperature	-65	150	°C
T_J	Junction temperature		150	°C
P_{tot}	Total power dissipation (QFN) ⁽⁵⁾		1650	mW
P_{tot}	Total power dissipation (TSSOP) ⁽⁵⁾		720	mW

- (1) Operation outside the *Absolute Maximum Ratings* may cause permanent device damage. *Absolute Maximum Ratings* do not imply functional operation of the device at these or any other conditions beyond those listed under *Recommended Operating Conditions*. If used outside the *Recommended Operating Conditions* but within the *Absolute Maximum Ratings*, the device may not be fully functional, and this may affect device reliability, functionality, performance, and shorten the device lifetime.
- (2) All voltages are with respect to ground, unless otherwise specified.
- (3) Pins are diode-clamped to the power-supply rails. Over voltage signals must be voltage and current limited to maximum ratings.
- (4) Refer to *Source or Drain Continuous Current* table for I_{DC} specifications.
- (5) For QFN package: P_{tot} derates linearly above $T_A = 70^\circ\text{C}$ by $24.2\text{mW}/^\circ\text{C}$.

5.2 ESD Ratings

		VALUE	UNIT
$V_{(ESD)}$	Electrostatic discharge	Human body model (HBM), per ANSI/ESDA/ JEDEC JS-001, all pins ⁽¹⁾	±1000
		Charged device model (CDM), per ANSI/ESDA/ JEDEC JS-002, all pins ⁽²⁾	±500

- (1) JEDEC document JEP155 states that 500-V HBM allows safe manufacturing with a standard ESD control process.
- (2) JEDEC document JEP157 states that 250-V CDM allows safe manufacturing with a standard ESD control process.

5.3 Thermal Information

THERMAL METRIC ⁽¹⁾		TMUX7236		UNIT
		RUM (WQFN)	PW (TSSOP)	
		16 PINS	16 PINS	
$R_{\theta JA}$	Junction-to-ambient thermal resistance	41.5	97.1	°C/W
$R_{\theta JC(top)}$	Junction-to-case (top) thermal resistance	25.1	25.6	°C/W
$R_{\theta JB}$	Junction-to-board thermal resistance	16.5	44.1	°C/W
Ψ_{JT}	Junction-to-top characterization parameter	0.3	1.1	°C/W
Ψ_{JB}	Junction-to-board characterization parameter	16.4	43.4	°C/W
$R_{\theta JC(bot)}$	Junction-to-case (bottom) thermal resistance	2.9	N/A	°C/W

(1) For more information about traditional and new thermal metrics, see the [Semiconductor and IC Package Thermal Metrics](#) application report.

5.4 Recommended Operating Conditions

over operating free-air temperature range (unless otherwise noted)

		MIN	NOM	MAX	UNIT
$V_{DD} - V_{SS}$ ⁽¹⁾	Power supply voltage differential	4.5		44	V
V_{DD}	Positive power supply voltage	4.5		44	V
V_S or V_D	Signal path input/output voltage (source or drain pin) (Sx, D)	V_{SS}		V_{DD}	V
V_{SEL} or V_{EN}	Address or enable pin voltage	0		44	V
I_S or $I_D (CONT)$	Source or drain continuous current (Sx, D)			I_{DC} ⁽²⁾	mA
T_A	Ambient temperature	-40		125	°C

(1) V_{DD} and V_{SS} can be any value as long as $4.5\text{ V} \leq (V_{DD} - V_{SS}) \leq 44\text{ V}$, and the minimum V_{DD} is met.

(2) Refer to *Source or Drain Continuous Current* table for I_{DC} specifications.

5.5 Source or Drain Continuous Current

at supply voltage of $V_{DD} \pm 10\%$, $V_{SS} \pm 10\%$ (unless otherwise noted)

CONTINUOUS CURRENT PER CHANNEL (I_{DC}) ⁽²⁾		$T_A = 25^\circ\text{C}$	$T_A = 85^\circ\text{C}$	$T_A = 125^\circ\text{C}$	UNIT
PACKAGE	TEST CONDITIONS				
PW (TSSOP)	+44 V Dual Supply ⁽¹⁾	470	300	165	mA
	$\pm 15\text{ V}$ Dual Supply	455	300	165	mA
	+12 V Single Supply	355	240	145	mA
	$\pm 5\text{ V}$ Dual Supply	335	225	140	mA
RUM (WQFN)	+44 V Single Supply ⁽¹⁾	650	400	180	mA
	$\pm 15\text{ V}$ Dual Supply	650	400	180	mA
	+12 V Single Supply	500	310	170	mA
	$\pm 5\text{ V}$ Dual Supply	450	290	160	mA

(1) Specified for nominal supply voltage only.

(2) Refer to Total power dissipation (P_{tot}) limits in *Absolute Maximum Ratings* table that must be followed with max continuous current specification.

5.6 ±15 V Dual Supply: Electrical Characteristics

$V_{DD} = +15\text{ V} \pm 10\%$, $V_{SS} = -15\text{ V} \pm 10\%$, GND = 0 V (unless otherwise noted)

Typical at $V_{DD} = +15\text{ V}$, $V_{SS} = -15\text{ V}$, $T_A = 25^\circ\text{C}$ (unless otherwise noted)

PARAMETER		TEST CONDITIONS	T_A	MIN	TYP	MAX	UNIT	
ANALOG SWITCH								
R_{ON}	On-resistance	$V_S = -10\text{ V to } +10\text{ V}$ $I_D = -10\text{ mA}$ Refer to On-Resistance	25°C		2	2.7	Ω	
			-40°C to +85°C			3.4	Ω	
			-40°C to +125°C			4	Ω	
ΔR_{ON}	On-resistance mismatch between channels	$V_S = -10\text{ V to } +10\text{ V}$ $I_D = -10\text{ mA}$ Refer to On-Resistance	25°C		0.1	0.18	Ω	
			-40°C to +85°C			0.19	Ω	
			-40°C to +125°C			0.21	Ω	
$R_{ON\ FLAT}$	On-resistance flatness	$V_S = -10\text{ V to } +10\text{ V}$ $I_S = -10\text{ mA}$ Refer to On-Resistance	25°C		0.2	0.46	Ω	
			-40°C to +85°C			0.65	Ω	
			-40°C to +125°C			0.7	Ω	
$R_{ON\ DRIFT}$	On-resistance drift	$V_S = 0\text{ V}$, $I_S = -10\text{ mA}$ Refer to On-Resistance	-40°C to +125°C		0.008		$\Omega/^\circ\text{C}$	
$I_{S(OFF)}$	Source off leakage current ⁽¹⁾	$V_{DD} = 16.5\text{ V}$, $V_{SS} = -16.5\text{ V}$ Switch state is off $V_S = +10\text{ V} / -10\text{ V}$ $V_D = -10\text{ V} / +10\text{ V}$ Refer to Off-Leakage Current	25°C	-0.25	0.05	0.25	nA	
			-40°C to +85°C		-3		3	nA
			-40°C to +125°C		-20		20	nA
$I_{D(OFF)}$	Drain off leakage current ⁽¹⁾	$V_{DD} = 16.5\text{ V}$, $V_{SS} = -16.5\text{ V}$ Switch state is off $V_S = +10\text{ V} / -10\text{ V}$ $V_D = -10\text{ V} / +10\text{ V}$ Refer to Off-Leakage Current	25°C	-0.6	0.1	0.6	nA	
			-40°C to +85°C		-7		7	nA
			-40°C to +125°C		-45		45	nA
$I_{S(ON)}$ $I_{D(ON)}$	Channel on leakage current ⁽²⁾	$V_{DD} = 16.5\text{ V}$, $V_{SS} = -16.5\text{ V}$ Switch state is on $V_S = V_D = \pm 10\text{ V}$ Refer to On-Leakage Current	25°C	-0.25	0.05	0.25	nA	
			-40°C to +85°C		-3		3	nA
			-40°C to +125°C		-20		20	nA
LOGIC INPUTS (SEL / EN pins)								
V_{IH}	Logic voltage high		-40°C to +125°C		1.3	44	V	
V_{IL}	Logic voltage low		-40°C to +125°C		0	0.8	V	
I_{IH}	Input leakage current		-40°C to +125°C		0.4	2	μA	
I_{IL}	Input leakage current		-40°C to +125°C	-1.5	-0.005		μA	
C_{IN}	Logic input capacitance		-40°C to +125°C		3.5		pF	
POWER SUPPLY								
I_{DD}	V_{DD} supply current	$V_{DD} = 16.5\text{ V}$, $V_{SS} = -16.5\text{ V}$ Logic inputs = 0 V, 5 V, or V_{DD}	25°C		35	56	μA	
			-40°C to +85°C			65	μA	
			-40°C to +125°C			80	μA	
I_{SS}	V_{SS} supply current	$V_{DD} = 16.5\text{ V}$, $V_{SS} = -16.5\text{ V}$ Logic inputs = 0 V, 5 V, or V_{DD}	25°C		5	20	μA	
			-40°C to +85°C			24	μA	
			-40°C to +125°C			35	μA	

(1) When V_S is positive, V_D is negative, or when V_S is negative, V_D is positive.

(2) When V_S is at a voltage potential, V_D is floating, or when V_D is at a voltage potential, V_S is floating.

5.7 ±15 V Dual Supply: Switching Characteristics

$V_{DD} = +15\text{ V} \pm 10\%$, $V_{SS} = -15\text{ V} \pm 10\%$, $GND = 0\text{ V}$ (unless otherwise noted)

Typical at $V_{DD} = +15\text{ V}$, $V_{SS} = -15\text{ V}$, $T_A = 25^\circ\text{C}$ (unless otherwise noted)

PARAMETER		TEST CONDITIONS	T_A	MIN	TYP	MAX	UNIT
t_{TRAN}	Transition time from control input	$V_S = 10\text{ V}$ $R_L = 300\ \Omega$, $C_L = 35\text{ pF}$ Refer to Transition Time	25°C		110	125	ns
			-40°C to +85°C			140	ns
			-40°C to +125°C			155	ns
t_{ON}	Turn-on time from control input	$V_S = 10\text{ V}$ $R_L = 300\ \Omega$, $C_L = 35\text{ pF}$ Refer to Turn-on and Turn-off Time	25°C		95	120	ns
			-40°C to +85°C			135	ns
			-40°C to +125°C			145	ns
t_{OFF}	Turn-off time from control input	$V_S = 10\text{ V}$ $R_L = 300\ \Omega$, $C_L = 35\text{ pF}$ Refer to Turn-on and Turn-off Time	25°C		125	160	ns
			-40°C to +85°C			175	ns
			-40°C to +125°C			190	ns
t_{BBM}	Break-before-make time delay	$V_S = 10\text{ V}$, $R_L = 300\ \Omega$, $C_L = 35\text{ pF}$ Refer to Break-before-make Time	25°C		27		ns
			-40°C to +85°C	5			ns
			-40°C to +125°C	5			ns
$t_{\text{ON}}(V_{DD})$	Device turn on time (V_{DD} to output)	V_{DD} rise time = 1 μs $R_L = 300\ \Omega$, $C_L = 35\text{ pF}$ Refer to Turn-on (VDD) Time	25°C		0.17		ms
			-40°C to +85°C			0.18	ms
			-40°C to +125°C			0.18	ms
t_{PD}	Propagation delay	$R_L = 50\ \Omega$, $C_L = 5\text{ pF}$ Refer to Propagation Delay	25°C		720		ps
Q_{INJ}	Charge injection	$V_S = 0\text{ V}$, $C_L = 100\text{ pF}$ Refer to Charge Injection	25°C		30		pC
O_{ISO}	Off-isolation	$R_L = 50\ \Omega$, $C_L = 5\text{ pF}$ $V_S = 0\text{ V}$, $f = 100\text{ kHz}$ Refer to Off Isolation	25°C		-70		dB
O_{ISO}	Off-isolation	$R_L = 50\ \Omega$, $C_L = 5\text{ pF}$ $V_S = 0\text{ V}$, $f = 1\text{ MHz}$ Refer to Off Isolation	25°C		-50		dB
X_{TALK}	Crosstalk	$R_L = 50\ \Omega$, $C_L = 5\text{ pF}$ $V_S = 0\text{ V}$, $f = 100\text{ kHz}$ Refer to Crosstalk	25°C		-107		dB
X_{TALK}	Crosstalk	$R_L = 50\ \Omega$, $C_L = 5\text{ pF}$ $V_S = 0\text{ V}$, $f = 1\text{ MHz}$ Refer to Crosstalk	25°C		-93		dB
BW	-3dB Bandwidth	$R_L = 50\ \Omega$, $C_L = 5\text{ pF}$ $V_S = 0\text{ V}$ Refer to Bandwidth	25°C		40		MHz
I_L	Insertion loss	$R_L = 50\ \Omega$, $C_L = 5\text{ pF}$ $V_S = 0\text{ V}$, $f = 1\text{ MHz}$	25°C		-0.15		dB
ACPSRR	AC Power Supply Rejection Ratio	$V_{PP} = 0.62\text{ V}$ on V_{DD} and V_{SS} $R_L = 50\ \Omega$, $C_L = 5\text{ pF}$, $f = 1\text{ MHz}$ Refer to ACPSRR	25°C		-68		dB
THD+N	Total Harmonic Distortion + Noise	$V_{PP} = 15\text{ V}$, $V_{\text{BIAS}} = 0\text{ V}$ $R_L = 10\text{ k}\Omega$, $C_L = 5\text{ pF}$, $f = 20\text{ Hz}$ to 20 kHz Refer to THD + Noise	25°C		0.0006		%
$C_{\text{S(OFF)}}$	Source off capacitance	$V_S = 0\text{ V}$, $f = 1\text{ MHz}$	25°C		45		pF
$C_{\text{D(OFF)}}$	Drain off capacitance	$V_S = 0\text{ V}$, $f = 1\text{ MHz}$	25°C		55		pF
$C_{\text{S(ON)}}$, $C_{\text{D(ON)}}$	On capacitance	$V_S = 0\text{ V}$, $f = 1\text{ MHz}$	25°C		165		pF

5.8 ±20 V Dual Supply: Electrical Characteristics

$V_{DD} = +20\text{ V} \pm 10\%$, $V_{SS} = -20\text{ V} \pm 10\%$, GND = 0 V (unless otherwise noted)

Typical at $V_{DD} = +20\text{ V}$, $V_{SS} = -20\text{ V}$, $T_A = 25^\circ\text{C}$ (unless otherwise noted)

PARAMETER		TEST CONDITIONS	T_A	MIN	TYP	MAX	UNIT
ANALOG SWITCH							
R_{ON}	On-resistance	$V_S = -15\text{ V to } +15\text{ V}$ $I_D = -10\text{ mA}$ Refer to On-Resistance	25°C		1.7	2.5	Ω
			-40°C to +85°C			3.2	Ω
			-40°C to +125°C			3.8	Ω
ΔR_{ON}	On-resistance mismatch between channels	$V_S = -15\text{ V to } +15\text{ V}$ $I_D = -10\text{ mA}$ Refer to On-Resistance	25°C		0.1	0.18	Ω
			-40°C to +85°C			0.19	Ω
			-40°C to +125°C			0.21	Ω
$R_{ON\ FLAT}$	On-resistance flatness	$V_S = -15\text{ V to } +15\text{ V}$ $I_S = -10\text{ mA}$ Refer to On-Resistance	25°C		0.3	0.6	Ω
			-40°C to +85°C			0.8	Ω
			-40°C to +125°C			0.95	Ω
$R_{ON\ DRIFT}$	On-resistance drift	$V_S = 0\text{ V}$, $I_S = -10\text{ mA}$ Refer to On-Resistance	-40°C to +125°C		0.008		$\Omega/^\circ\text{C}$
$I_{S(OFF)}$	Source off leakage current ⁽¹⁾	$V_{DD} = 22\text{ V}$, $V_{SS} = -22\text{ V}$ Switch state is off $V_S = +15\text{ V} / -15\text{ V}$ $V_D = -15\text{ V} / +15\text{ V}$ Refer to Off-Leakage Current	25°C	-1	0.05	1	nA
			-40°C to +85°C			4.5	nA
			-40°C to +125°C			33	nA
$I_{D(OFF)}$	Drain off leakage current ⁽¹⁾	$V_{DD} = 22\text{ V}$, $V_{SS} = -22\text{ V}$ Switch state is off $V_S = +15\text{ V} / -15\text{ V}$ $V_D = -15\text{ V} / +15\text{ V}$ Refer to Off-Leakage Current	25°C	-2.2	0.22	2.2	nA
			-40°C to +85°C			10	nA
			-40°C to +125°C			70	nA
$I_{S(ON)}$ $I_{D(ON)}$	Channel on leakage current ⁽²⁾	$V_{DD} = 22\text{ V}$, $V_{SS} = -22\text{ V}$ Switch state is on $V_S = V_D = \pm 15\text{ V}$ Refer to On-Leakage Current	25°C	-1	0.05	1	nA
			-40°C to +85°C			4.5	nA
			-40°C to +125°C			33	nA
LOGIC INPUTS (SEL / EN pins)							
V_{IH}	Logic voltage high		-40°C to +125°C		1.3	44	V
V_{IL}	Logic voltage low		-40°C to +125°C		0	0.8	V
I_{IH}	Input leakage current		-40°C to +125°C		0.4	2	μA
I_{IL}	Input leakage current		-40°C to +125°C	-1.2	-0.005		μA
C_{IN}	Logic input capacitance		-40°C to +125°C		3.5		pF
POWER SUPPLY							
I_{DD}	V_{DD} supply current	$V_{DD} = 22\text{ V}$, $V_{SS} = -22\text{ V}$ Logic inputs = 0 V, 5 V, or V_{DD}	25°C		33	65	μA
			-40°C to +85°C			74	μA
			-40°C to +125°C			90	μA
I_{SS}	V_{SS} supply current	$V_{DD} = 22\text{ V}$, $V_{SS} = -22\text{ V}$ Logic inputs = 0 V, 5 V, or V_{DD}	25°C		7	26	μA
			-40°C to +85°C			30	μA
			-40°C to +125°C			45	μA

(1) When V_S is positive, V_D is negative, or when V_S is negative, V_D is positive.

(2) When V_S is at a voltage potential, V_D is floating, or when V_D is at a voltage potential, V_S is floating.

5.9 ±20 V Dual Supply: Switching Characteristics

$V_{DD} = +20\text{ V} \pm 10\%$, $V_{SS} = -20\text{ V} \pm 10\%$, $GND = 0\text{ V}$ (unless otherwise noted)

Typical at $V_{DD} = +20\text{ V}$, $V_{SS} = -20\text{ V}$, $T_A = 25^\circ\text{C}$ (unless otherwise noted)

PARAMETER		TEST CONDITIONS	T_A	MIN	TYP	MAX	UNIT
t_{TRAN}	Transition time from control input	$V_S = 10\text{ V}$ $R_L = 300\ \Omega$, $C_L = 35\text{ pF}$ Refer to Transition Time	25°C		100	160	ns
			-40°C to +85°C			170	ns
			-40°C to +125°C			180	ns
t_{ON}	Turn-on time from control input	$V_S = 10\text{ V}$ $R_L = 300\ \Omega$, $C_L = 35\text{ pF}$ Refer to Turn-on and Turn-off Time	25°C		95	140	ns
			-40°C to +85°C			160	ns
			-40°C to +125°C			180	ns
t_{OFF}	Turn-off time from control input	$V_S = 10\text{ V}$ $R_L = 300\ \Omega$, $C_L = 35\text{ pF}$ Refer to Turn-on and Turn-off Time	25°C		125	150	ns
			-40°C to +85°C			165	ns
			-40°C to +125°C			190	ns
t_{BBM}	Break-before-make time delay	$V_S = 10\text{ V}$, $R_L = 300\ \Omega$, $C_L = 35\text{ pF}$ Refer to Break-before-make Time	25°C		28		ns
			-40°C to +85°C	5			ns
			-40°C to +125°C	5			ns
$t_{\text{ON}}(V_{DD})$	Device turn on time (V_{DD} to output)	V_{DD} rise time = 1 μs $R_L = 300\ \Omega$, $C_L = 35\text{ pF}$ Refer to Turn-on (VDD) Time	25°C		0.17		ms
			-40°C to +85°C			0.18	ms
			-40°C to +125°C			0.18	ms
t_{PD}	Propagation delay	$R_L = 50\ \Omega$, $C_L = 5\text{ pF}$ Refer to Propagation Delay	25°C		740		ps
Q_{INJ}	Charge injection	$V_S = 0\text{ V}$, $C_L = 100\text{ pF}$ Refer to Charge Injection	25°C		45		pC
O_{ISO}	Off-isolation	$R_L = 50\ \Omega$, $C_L = 5\text{ pF}$ $V_S = 0\text{ V}$, $f = 100\text{ kHz}$ Refer to Off Isolation	25°C		-70		dB
O_{ISO}	Off-isolation	$R_L = 50\ \Omega$, $C_L = 5\text{ pF}$ $V_S = 0\text{ V}$, $f = 1\text{ MHz}$ Refer to Off Isolation	25°C		-50		dB
X_{TALK}	Crosstalk	$R_L = 50\ \Omega$, $C_L = 5\text{ pF}$ $V_S = 0\text{ V}$, $f = 100\text{ kHz}$ Refer to Crosstalk	25°C		-107		dB
X_{TALK}	Crosstalk	$R_L = 50\ \Omega$, $C_L = 5\text{ pF}$ $V_S = 0\text{ V}$, $f = 1\text{ MHz}$ Refer to Crosstalk	25°C		-93		dB
BW	-3dB Bandwidth	$R_L = 50\ \Omega$, $C_L = 5\text{ pF}$ $V_S = 0\text{ V}$ Refer to Bandwidth	25°C		35		MHz
I_L	Insertion loss	$R_L = 50\ \Omega$, $C_L = 5\text{ pF}$ $V_S = 0\text{ V}$, $f = 1\text{ MHz}$	25°C		-0.14		dB
ACPSRR	AC Power Supply Rejection Ratio	$V_{PP} = 0.62\text{ V}$ on V_{DD} and V_{SS} $R_L = 50\ \Omega$, $C_L = 5\text{ pF}$, $f = 1\text{ MHz}$ Refer to ACPSRR	25°C		-68		dB
THD+N	Total Harmonic Distortion + Noise	$V_{PP} = 20\text{ V}$, $V_{\text{BIAS}} = 0\text{ V}$ $R_L = 10\text{ k}\Omega$, $C_L = 5\text{ pF}$, $f = 20\text{ Hz}$ to 20 kHz Refer to THD + Noise	25°C		0.0006		%
$C_{\text{S(OFF)}}$	Source off capacitance	$V_S = 0\text{ V}$, $f = 1\text{ MHz}$	25°C		45		pF
$C_{\text{D(OFF)}}$	Drain off capacitance	$V_S = 0\text{ V}$, $f = 1\text{ MHz}$	25°C		55		pF
$C_{\text{S(ON)}}$, $C_{\text{D(ON)}}$	On capacitance	$V_S = 0\text{ V}$, $f = 1\text{ MHz}$	25°C		165		pF

5.10 44 V Single Supply: Electrical Characteristics

$V_{DD} = +44\text{ V}$, $V_{SS} = 0\text{ V}$, GND = 0 V (unless otherwise noted)

Typical at $V_{DD} = +44\text{ V}$, $V_{SS} = 0\text{ V}$, $T_A = 25^\circ\text{C}$ (unless otherwise noted)

PARAMETER		TEST CONDITIONS	T_A	MIN	TYP	MAX	UNIT
ANALOG SWITCH							
R_{ON}	On-resistance	$V_S = 0\text{ V to }40\text{ V}$ $I_D = -10\text{ mA}$ Refer to On-Resistance	25°C		2	2.4	Ω
			-40°C to +85°C			3.2	Ω
			-40°C to +125°C			3.8	Ω
ΔR_{ON}	On-resistance mismatch between channels	$V_S = 0\text{ V to }40\text{ V}$ $I_D = -10\text{ mA}$ Refer to On-Resistance	25°C		0.1	0.18	Ω
			-40°C to +85°C			0.19	Ω
			-40°C to +125°C			0.21	Ω
$R_{ON\ FLAT}$	On-resistance flatness	$V_S = 0\text{ V to }40\text{ V}$ $I_D = -10\text{ mA}$ Refer to On-Resistance	25°C		0.65	0.8	Ω
			-40°C to +85°C			1.1	Ω
			-40°C to +125°C			1.2	Ω
$R_{ON\ DRIFT}$	On-resistance drift	$V_S = 22\text{ V}$, $I_S = -10\text{ mA}$ Refer to On-Resistance	-40°C to +125°C		0.007		$\Omega/^\circ\text{C}$
$I_{S(OFF)}$	Source off leakage current ⁽¹⁾	$V_{DD} = 44\text{ V}$, $V_{SS} = 0\text{ V}$ Switch state is off $V_S = 40\text{ V} / 1\text{ V}$ $V_D = 1\text{ V} / 40\text{ V}$ Refer to Off-Leakage Current	25°C	-1	0.05	1	nA
			-40°C to +85°C			7	nA
			-40°C to +125°C			50	nA
$I_{D(OFF)}$	Drain off leakage current ⁽¹⁾	$V_{DD} = 44\text{ V}$, $V_{SS} = 0\text{ V}$ Switch state is off $V_S = 40\text{ V} / 1\text{ V}$ $V_D = 1\text{ V} / 40\text{ V}$ Refer to Off-Leakage Current	25°C	-2.2	0.12	2.2	nA
			-40°C to +85°C			15	nA
			-40°C to +125°C			115	nA
$I_{S(ON)}$ $I_{D(ON)}$	Channel on leakage current ⁽²⁾	$V_{DD} = 44\text{ V}$, $V_{SS} = 0\text{ V}$ Switch state is on $V_S = V_D = 40\text{ V or }1\text{ V}$ Refer to On-Leakage Current	25°C	-1	0.05	1	nA
			-40°C to +85°C			7	nA
			-40°C to +125°C			50	nA
LOGIC INPUTS (SEL / EN pins)							
V_{IH}	Logic voltage high		-40°C to +125°C	1.3		44	V
V_{IL}	Logic voltage low		-40°C to +125°C	0		0.8	V
I_{IH}	Input leakage current		-40°C to +125°C		1	2.75	μA
I_{IL}	Input leakage current		-40°C to +125°C	-1.2	-0.005		μA
C_{IN}	Logic input capacitance		-40°C to +125°C		3.5		pF
POWER SUPPLY							
I_{DD}	V_{DD} supply current	$V_{DD} = 44\text{ V}$, $V_{SS} = 0\text{ V}$ Logic inputs = 0 V, 5 V, or V_{DD}	25°C		44	79	μA
			-40°C to +85°C			88	μA
			-40°C to +125°C			105	μA

(1) When V_S is positive, V_D is negative, or when V_S is negative, V_D is positive.

(2) When V_S is at a voltage potential, V_D is floating, or when V_D is at a voltage potential, V_S is floating.

5.11 44 V Single Supply: Switching Characteristics

$V_{DD} = +44\text{ V}$, $V_{SS} = 0\text{ V}$, $GND = 0\text{ V}$ (unless otherwise noted)
 Typical at $V_{DD} = +44\text{ V}$, $V_{SS} = 0\text{ V}$, $T_A = 25^\circ\text{C}$ (unless otherwise noted)

PARAMETER		TEST CONDITIONS	T_A	MIN	TYP	MAX	UNIT
t_{TRAN}	Transition time from control input	$V_S = 18\text{ V}$ $R_L = 300\ \Omega$, $C_L = 35\text{ pF}$ Refer to Transition Time	25°C		85	145	ns
			-40°C to +85°C			155	ns
			-40°C to +125°C			185	ns
t_{ON}	Turn-on time from control input	$V_S = 18\text{ V}$ $R_L = 300\ \Omega$, $C_L = 35\text{ pF}$ Refer to Turn-on and Turn-off Time	25°C		90	130	ns
			-40°C to +85°C			140	ns
			-40°C to +125°C			160	ns
t_{OFF}	Turn-off time from control input	$V_S = 18\text{ V}$ $R_L = 300\ \Omega$, $C_L = 35\text{ pF}$ Refer to Turn-on and Turn-off Time	25°C		125	160	ns
			-40°C to +85°C			170	ns
			-40°C to +125°C			180	ns
t_{BBM}	Break-before-make time delay	$V_S = 18\text{ V}$, $R_L = 300\ \Omega$, $C_L = 35\text{ pF}$ Refer to Break-before-make Time	25°C		27		ns
			-40°C to +85°C		10		ns
			-40°C to +125°C		10		ns
$t_{\text{ON}}(V_{DD})$	Device turn on time (V_{DD} to output)	V_{DD} rise time = 1 μs $R_L = 300\ \Omega$, $C_L = 35\text{ pF}$ Refer to Turn-on (VDD) Time	25°C		0.14		ms
			-40°C to +85°C			0.15	ms
			-40°C to +125°C			0.15	ms
t_{PD}	Propagation delay	$R_L = 50\ \Omega$, $C_L = 5\text{ pF}$ Refer to Propagation Delay	25°C		900		ps
Q_{INJ}	Charge injection	$V_S = 22\text{ V}$, $C_L = 100\text{ pF}$ Refer to Charge Injection	25°C		104		pC
O_{ISO}	Off-isolation	$R_L = 50\ \Omega$, $C_L = 5\text{ pF}$ $V_S = 6\text{ V}$, $f = 100\text{ kHz}$ Refer to Off Isolation	25°C		-70		dB
O_{ISO}	Off-isolation	$R_L = 50\ \Omega$, $C_L = 5\text{ pF}$ $V_S = 6\text{ V}$, $f = 1\text{ MHz}$ Refer to Off Isolation	25°C		-50		dB
X_{TALK}	Crosstalk	$R_L = 50\ \Omega$, $C_L = 5\text{ pF}$ $V_S = 6\text{ V}$, $f = 100\text{ kHz}$ Refer to Crosstalk	25°C		-112		dB
X_{TALK}	Crosstalk	$R_L = 50\ \Omega$, $C_L = 5\text{ pF}$ $V_S = 6\text{ V}$, $f = 1\text{ MHz}$ Refer to Crosstalk	25°C		-93		dB
BW	-3dB Bandwidth	$R_L = 50\ \Omega$, $C_L = 5\text{ pF}$ $V_S = 6\text{ V}$ Refer to Bandwidth	25°C		35		MHz
I_L	Insertion loss	$R_L = 50\ \Omega$, $C_L = 5\text{ pF}$ $V_S = 6\text{ V}$, $f = 1\text{ MHz}$	25°C		-0.15		dB
ACPSRR	AC Power Supply Rejection Ratio	$V_{PP} = 0.62\text{ V}$ on V_{DD} and V_{SS} $R_L = 50\ \Omega$, $C_L = 5\text{ pF}$, $f = 1\text{ MHz}$ Refer to ACPSRR	25°C		-66		dB
THD+N	Total Harmonic Distortion + Noise	$V_{PP} = 22\text{ V}$, $V_{\text{BIAS}} = 22\text{ V}$ $R_L = 10\text{ k}\Omega$, $C_L = 5\text{ pF}$, $f = 20\text{ Hz}$ to 20 kHz Refer to THD + Noise	25°C		0.0006		%
$C_{\text{S(OFF)}}$	Source off capacitance	$V_S = 22\text{ V}$, $f = 1\text{ MHz}$	25°C		45		pF
$C_{\text{D(OFF)}}$	Drain off capacitance	$V_S = 22\text{ V}$, $f = 1\text{ MHz}$	25°C		55		pF
$C_{\text{S(ON)}}$, $C_{\text{D(ON)}}$	On capacitance	$V_S = 22\text{ V}$, $f = 1\text{ MHz}$	25°C		165		pF

5.12 12 V Single Supply: Electrical Characteristics

$V_{DD} = +12\text{ V} \pm 10\%$, $V_{SS} = 0\text{ V}$, $GND = 0\text{ V}$ (unless otherwise noted)

Typical at $V_{DD} = +12\text{ V}$, $V_{SS} = 0\text{ V}$, $T_A = 25^\circ\text{C}$ (unless otherwise noted)

PARAMETER		TEST CONDITIONS	T_A	MIN	TYP	MAX	UNIT	
ANALOG SWITCH								
R_{ON}	On-resistance	$V_S = 0\text{ V to }10\text{ V}$ $I_D = -10\text{ mA}$ Refer to On-Resistance	25°C		2.8	5.4	Ω	
			-40°C to +85°C			6.8	Ω	
			-40°C to +125°C			7.4	Ω	
ΔR_{ON}	On-resistance mismatch between channels	$V_S = 0\text{ V to }10\text{ V}$ $I_D = -10\text{ mA}$ Refer to On-Resistance	25°C		0.13	0.21	Ω	
			-40°C to +85°C			0.23	Ω	
			-40°C to +125°C			0.25	Ω	
$R_{ON\text{ FLAT}}$	On-resistance flatness	$V_S = 0\text{ V to }10\text{ V}$ $I_D = -10\text{ mA}$ Refer to On-Resistance	25°C		0.8	1.7	Ω	
			-40°C to +85°C			1.9	Ω	
			-40°C to +125°C			2	Ω	
$R_{ON\text{ DRIFT}}$	On-resistance drift	$V_S = 6\text{ V}$, $I_S = -10\text{ mA}$ Refer to On-Resistance	-40°C to +125°C		0.015		$\Omega/^\circ\text{C}$	
$I_{S(OFF)}$	Source off leakage current ⁽¹⁾	$V_{DD} = 13.2\text{ V}$, $V_{SS} = 0\text{ V}$ Switch state is off $V_S = 10\text{ V} / 1\text{ V}$ $V_D = 1\text{ V} / 10\text{ V}$ Refer to Off-Leakage Current	25°C	-0.25	0.01	0.25	nA	
			-40°C to +85°C		-2		2	nA
			-40°C to +125°C		-16		16	nA
$I_{D(OFF)}$	Drain off leakage current ⁽¹⁾	$V_{DD} = 13.2\text{ V}$, $V_{SS} = 0\text{ V}$ Switch state is off $V_S = 10\text{ V} / 1\text{ V}$ $V_D = 1\text{ V} / 10\text{ V}$ Refer to Off-Leakage Current	25°C	-0.6	0.12	0.6	nA	
			-40°C to +85°C		-5		5	nA
			-40°C to +125°C		-34		34	nA
$I_{S(ON)}$ $I_{D(ON)}$	Channel on leakage current ⁽²⁾	$V_{DD} = 13.2\text{ V}$, $V_{SS} = 0\text{ V}$ Switch state is on $V_S = V_D = 10\text{ V}$ or 1 V Refer to On-Leakage Current	25°C	-0.25	0.01	0.25	nA	
			-40°C to +85°C		-2		2	nA
			-40°C to +125°C		-16		16	nA
LOGIC INPUTS (SEL / EN pins)								
V_{IH}	Logic voltage high		-40°C to +125°C		1.3	44	V	
V_{IL}	Logic voltage low		-40°C to +125°C		0	0.8	V	
I_{IH}	Input leakage current		-40°C to +125°C		0.4	2.25	μA	
I_{IL}	Input leakage current		-40°C to +125°C	-1.25	-0.005		μA	
C_{IN}	Logic input capacitance		-40°C to +125°C		3.5		pF	
POWER SUPPLY								
I_{DD}	V_{DD} supply current	$V_{DD} = 13.2\text{ V}$, $V_{SS} = 0\text{ V}$ Logic inputs = 0 V , 5 V , or V_{DD}	25°C		30	44	μA	
			-40°C to +85°C			52	μA	
			-40°C to +125°C			62	μA	

(1) When V_S is positive, V_D is negative, or when V_S is negative, V_D is positive.

(2) When V_S is at a voltage potential, V_D is floating, or when V_D is at a voltage potential, V_S is floating.

5.13 12 V Single Supply: Switching Characteristics

$V_{DD} = +12\text{ V} \pm 10\%$, $V_{SS} = 0\text{ V}$, $GND = 0\text{ V}$ (unless otherwise noted)

Typical at $V_{DD} = +12\text{ V}$, $V_{SS} = 0\text{ V}$, $T_A = 25^\circ\text{C}$ (unless otherwise noted)

PARAMETER		TEST CONDITIONS	T_A	MIN	TYP	MAX	UNIT
t_{TRAN}	Transition time from control input	$V_S = 8\text{ V}$ $R_L = 300\ \Omega$, $C_L = 35\text{ pF}$ Refer to Transition Time	25°C		90	160	ns
			-40°C to +85°C			190	ns
			-40°C to +125°C			225	ns
t_{ON}	Turn-on time from control input	$V_S = 8\text{ V}$ $R_L = 300\ \Omega$, $C_L = 35\text{ pF}$ Refer to Turn-on and Turn-off Time	25°C		190	235	ns
			-40°C to +85°C			260	ns
			-40°C to +125°C			280	ns
t_{OFF}	Turn-off time from control input	$V_S = 8\text{ V}$ $R_L = 300\ \Omega$, $C_L = 35\text{ pF}$ Refer to Turn-on and Turn-off Time	25°C		160	200	ns
			-40°C to +85°C			220	ns
			-40°C to +125°C			245	ns
t_{BBM}	Break-before-make time delay	$V_S = 8\text{ V}$, $R_L = 300\ \Omega$, $C_L = 35\text{ pF}$ Refer to Break-before-make Time	25°C		30		ns
			-40°C to +85°C	9			ns
			-40°C to +125°C	9			ns
$t_{\text{ON}}(V_{DD})$	Device turn on time (V_{DD} to output)	V_{DD} rise time = 1 μs $R_L = 300\ \Omega$, $C_L = 35\text{ pF}$ Refer to Turn-on (VDD) Time	25°C		0.17		ms
			-40°C to +85°C			0.18	ms
			-40°C to +125°C			0.18	ms
t_{PD}	Propagation delay	$R_L = 50\ \Omega$, $C_L = 5\text{ pF}$ Refer to Propagation Delay	25°C		770		ps
Q_{INJ}	Charge injection	$V_S = 6\text{ V}$, $C_L = 100\text{ pF}$ Refer to Charge Injection	25°C		12		pC
O_{ISO}	Off-isolation	$R_L = 50\ \Omega$, $C_L = 5\text{ pF}$ $V_S = 6\text{ V}$, $f = 100\text{ kHz}$ Refer to Off Isolation	25°C		-70		dB
O_{ISO}	Off-isolation	$R_L = 50\ \Omega$, $C_L = 5\text{ pF}$ $V_S = 6\text{ V}$, $f = 1\text{ MHz}$ Refer to Off Isolation	25°C		-50		dB
X_{TALK}	Crosstalk	$R_L = 50\ \Omega$, $C_L = 5\text{ pF}$ $V_S = 6\text{ V}$, $f = 100\text{ kHz}$ Refer to Crosstalk	25°C		-112		dB
X_{TALK}	Crosstalk	$R_L = 50\ \Omega$, $C_L = 5\text{ pF}$ $V_S = 6\text{ V}$, $f = 1\text{ MHz}$ Refer to Crosstalk	25°C		-93		dB
BW	-3dB Bandwidth	$R_L = 50\ \Omega$, $C_L = 5\text{ pF}$ $V_S = 6\text{ V}$ Refer to Bandwidth	25°C		50		MHz
I_L	Insertion loss	$R_L = 50\ \Omega$, $C_L = 5\text{ pF}$ $V_S = 6\text{ V}$, $f = 1\text{ MHz}$	25°C		-0.25		dB
ACPSRR	AC Power Supply Rejection Ratio	$V_{PP} = 0.62\text{ V}$ on V_{DD} and V_{SS} $R_L = 50\ \Omega$, $C_L = 5\text{ pF}$, $f = 1\text{ MHz}$ Refer to ACPSRR	25°C		-70		dB
THD+N	Total Harmonic Distortion + Noise	$V_{PP} = 6\text{ V}$, $V_{\text{BIAS}} = 6\text{ V}$ $R_L = 10\text{ k}\Omega$, $C_L = 5\text{ pF}$, $f = 20\text{ Hz}$ to 20 kHz Refer to THD + Noise	25°C		0.001		%
$C_{\text{S(OFF)}}$	Source off capacitance	$V_S = 6\text{ V}$, $f = 1\text{ MHz}$	25°C		52		pF
$C_{\text{D(OFF)}}$	Drain off capacitance	$V_S = 6\text{ V}$, $f = 1\text{ MHz}$	25°C		68		pF
$C_{\text{S(ON)}}$, $C_{\text{D(ON)}}$	On capacitance	$V_S = 6\text{ V}$, $f = 1\text{ MHz}$	25°C		170		pF

5.14 Typical Characteristics

at $T_A = 25^\circ\text{C}$ (unless otherwise noted)

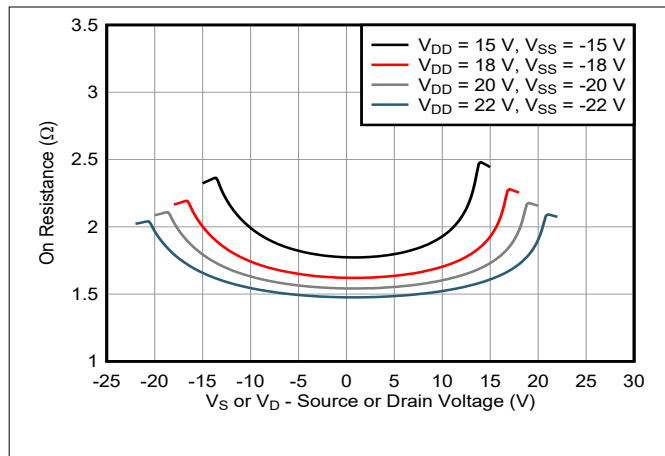

5-1. On-Resistance vs Source or Drain Voltage – Dual Supply

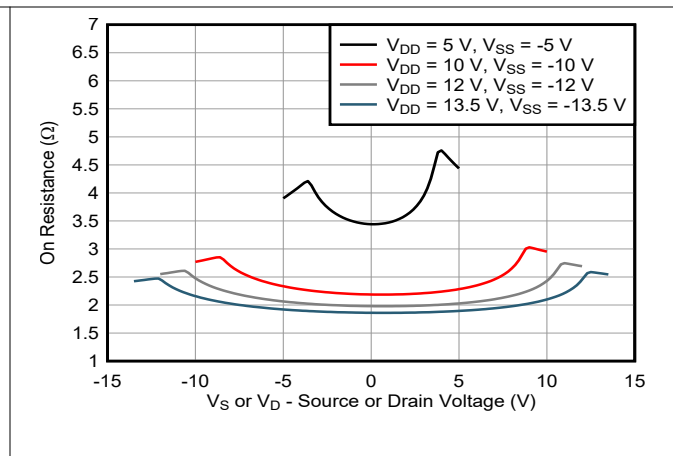

5-2. On-Resistance vs Source or Drain Voltage – Dual Supply

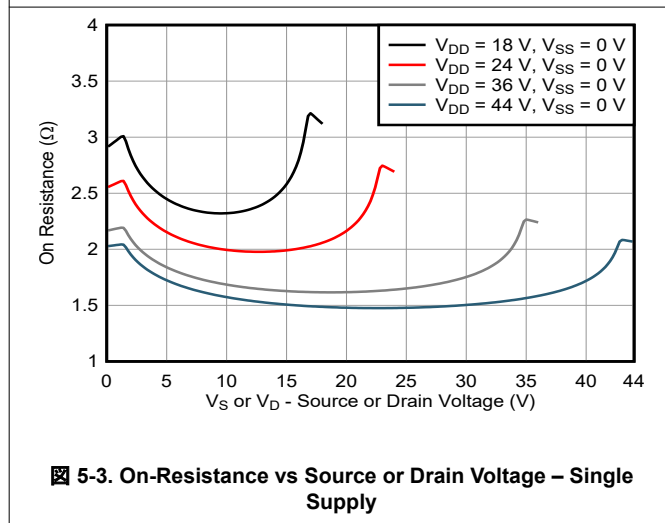

5-3. On-Resistance vs Source or Drain Voltage – Single Supply

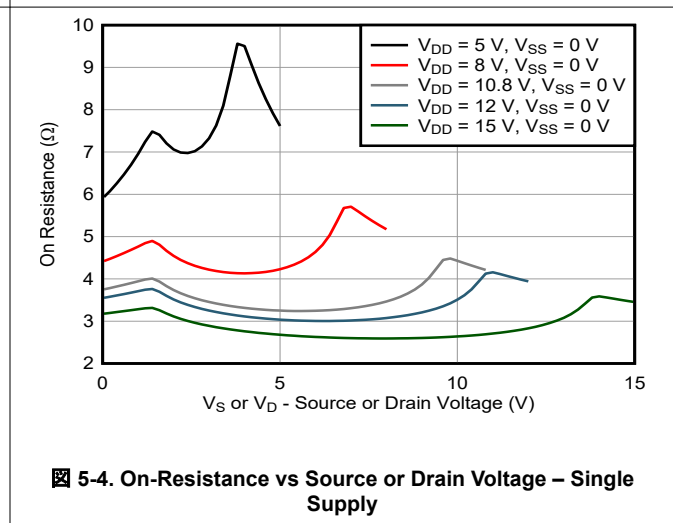

5-4. On-Resistance vs Source or Drain Voltage – Single Supply

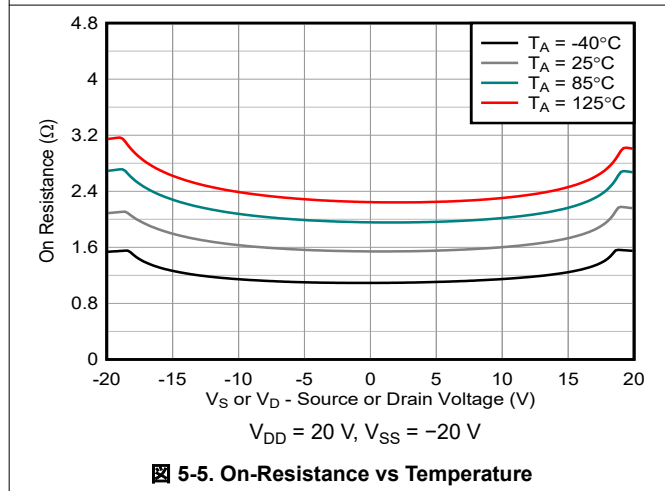

5-5. On-Resistance vs Temperature

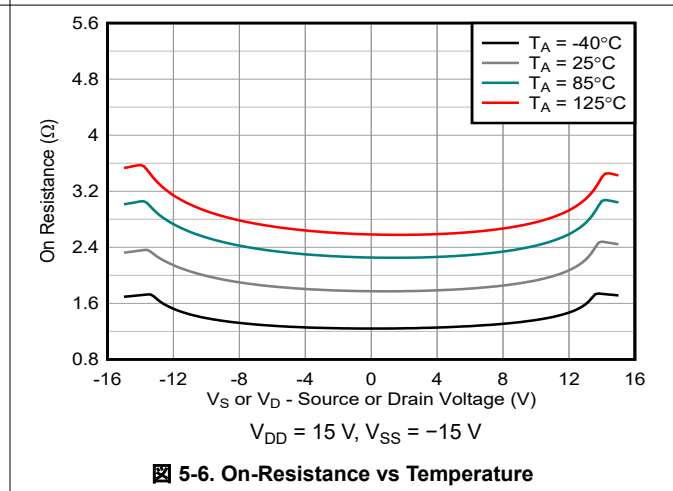

5-6. On-Resistance vs Temperature

5.14 Typical Characteristics (continued)

at $T_A = 25^\circ\text{C}$ (unless otherwise noted)

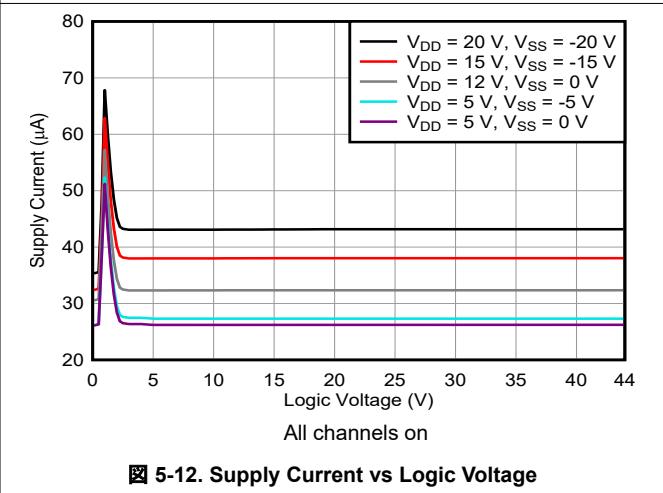
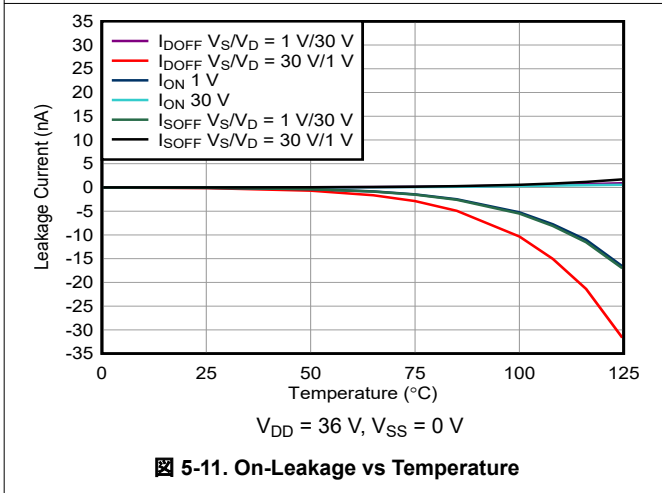
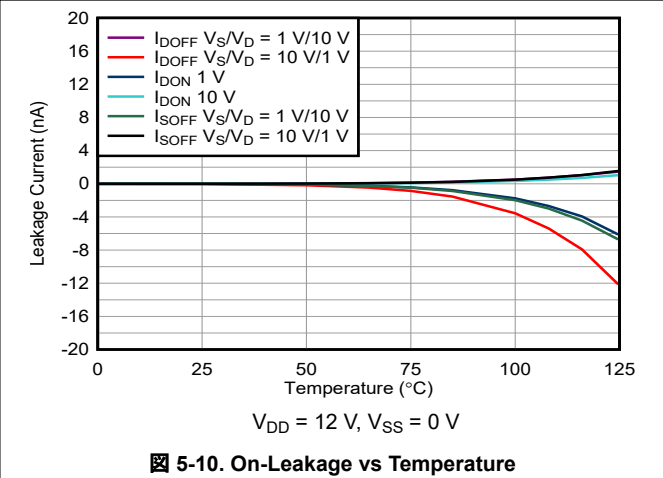
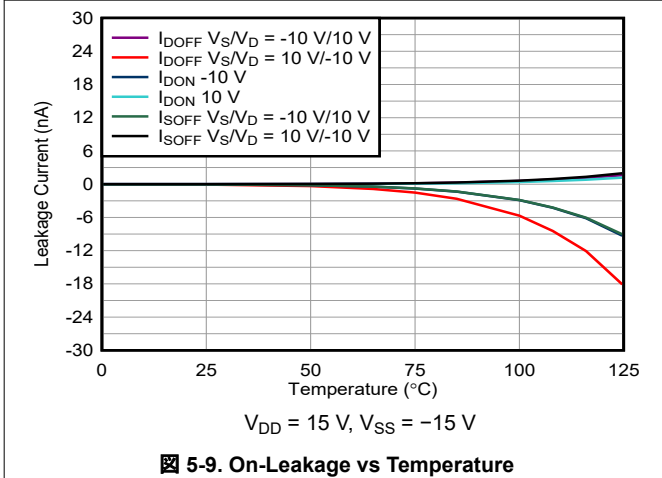
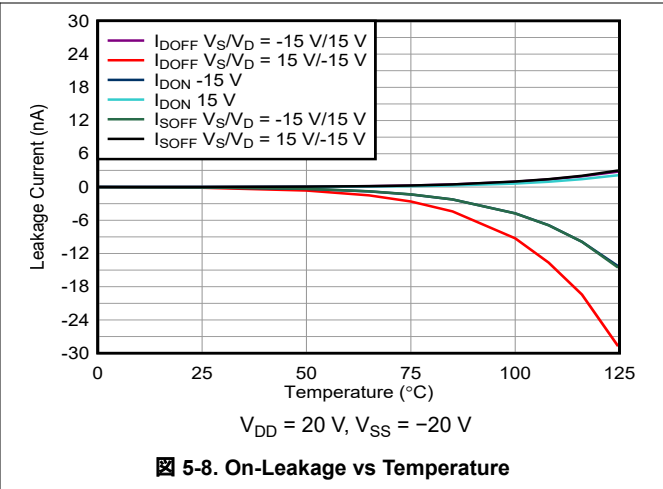
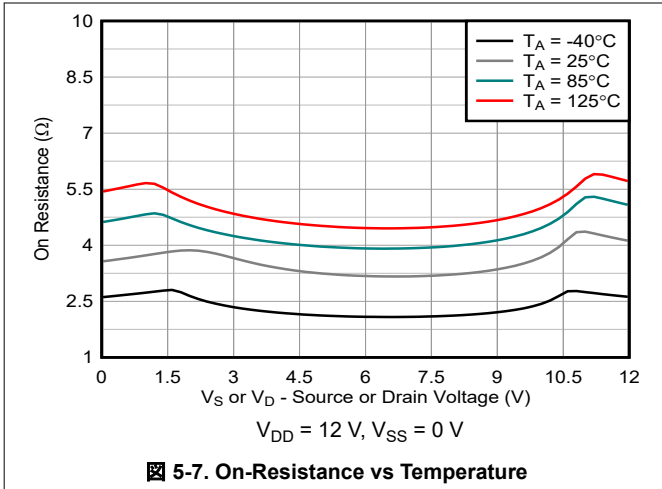

5.14 Typical Characteristics (continued)

at $T_A = 25^\circ\text{C}$ (unless otherwise noted)



图 5-13. Charge Injection vs Source Voltage – Dual Supply



图 5-14. Charge Injection vs Drain Voltage – Dual Supply

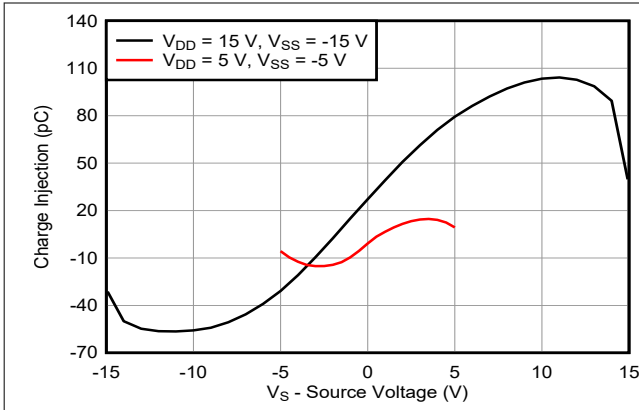

图 5-15. Charge Injection vs Source Voltage – Single Supply

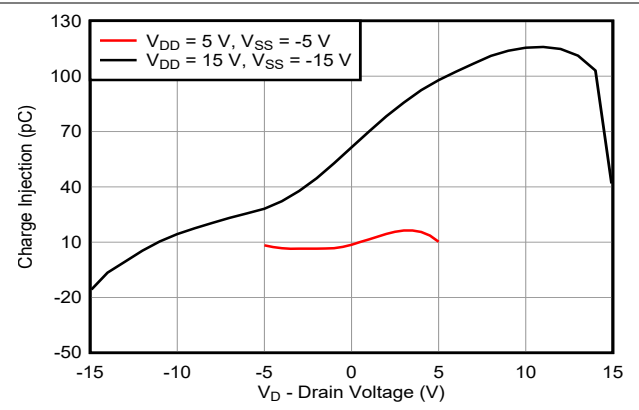

图 5-16. Charge Injection vs Drain Voltage – Single Supply

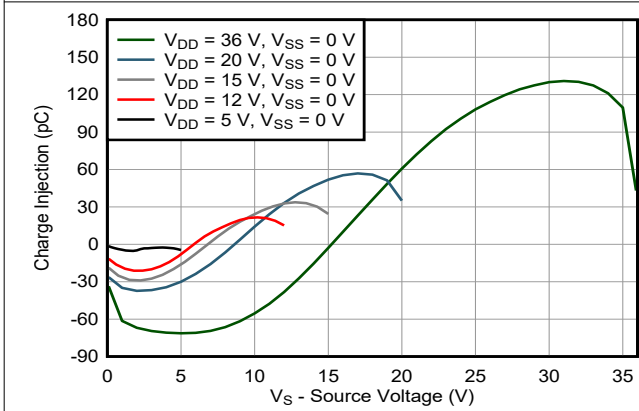

图 5-17. $T_{\text{TRANSITION}}$ vs Temperature

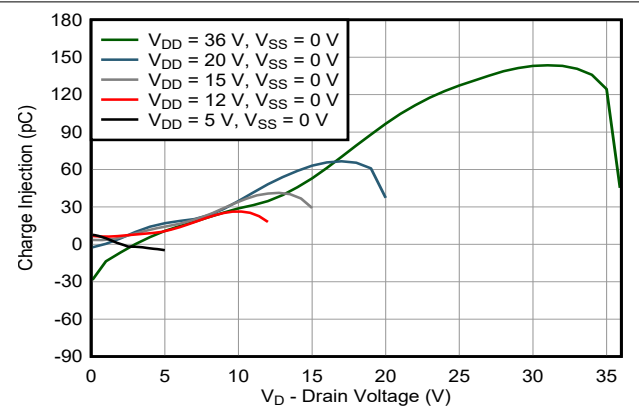

图 5-18. $T_{\text{TRANSITION}}$ vs Temperature

5.14 Typical Characteristics (continued)

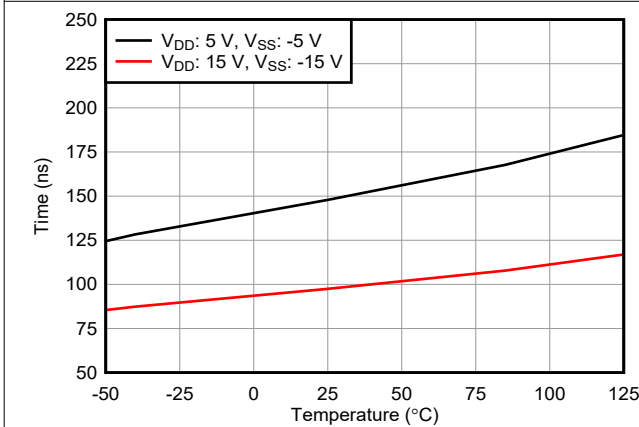
at $T_A = 25^\circ\text{C}$ (unless otherwise noted)

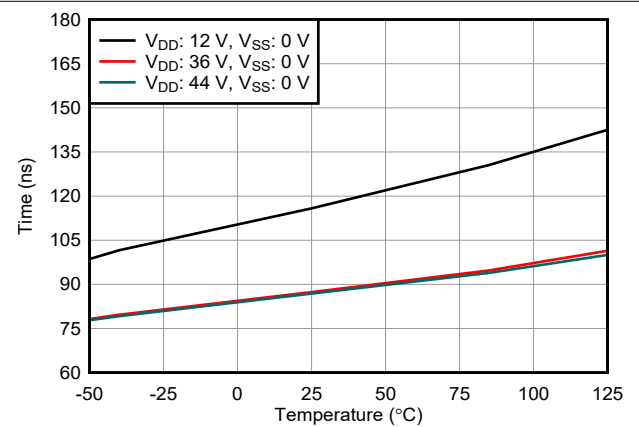
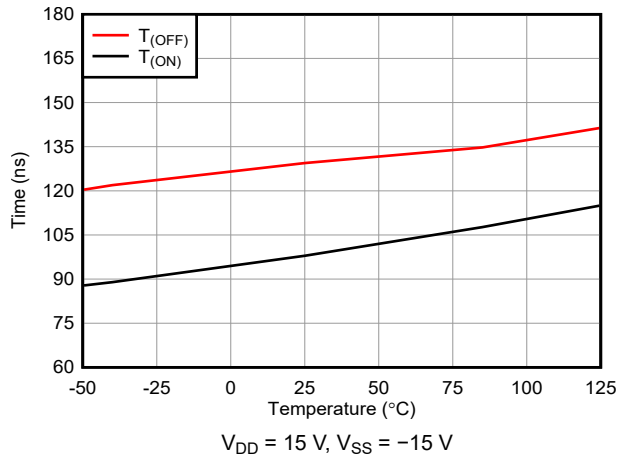

5-19. T_{ON} (EN) and T_{OFF} (EN) vs Temperature

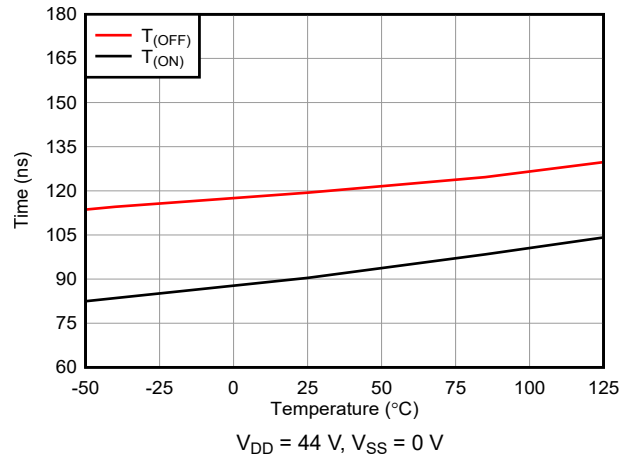

5-20. T_{ON} (EN) and T_{OFF} (EN) vs Temperature

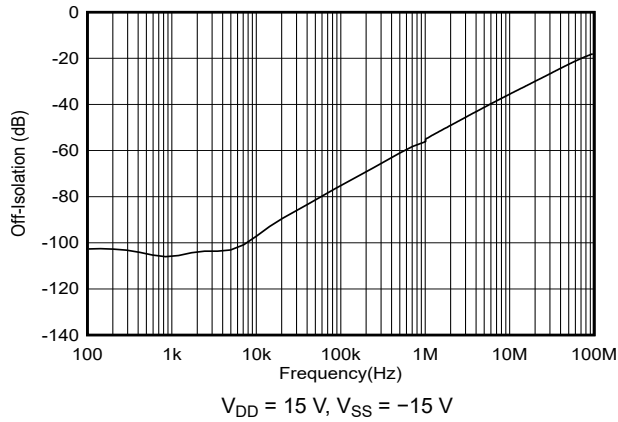

5-21. Off-Isolation vs Frequency

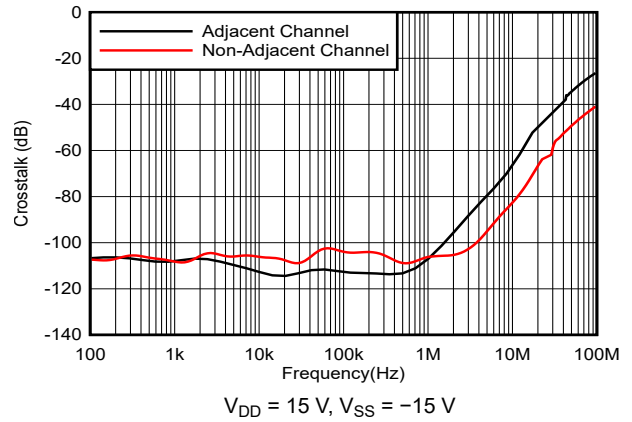

5-22. Crosstalk vs Frequency

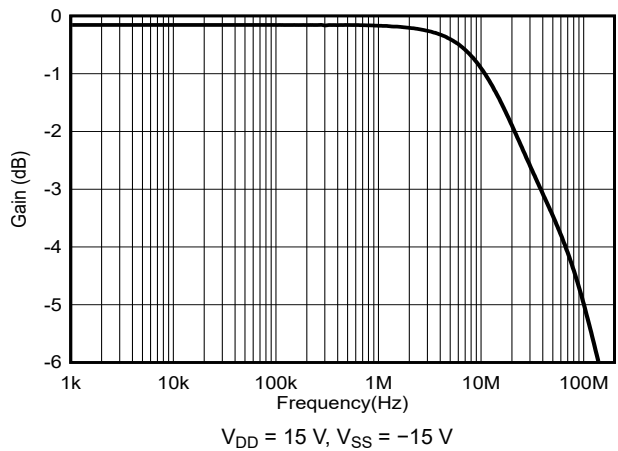

5-23. On Response vs Frequency

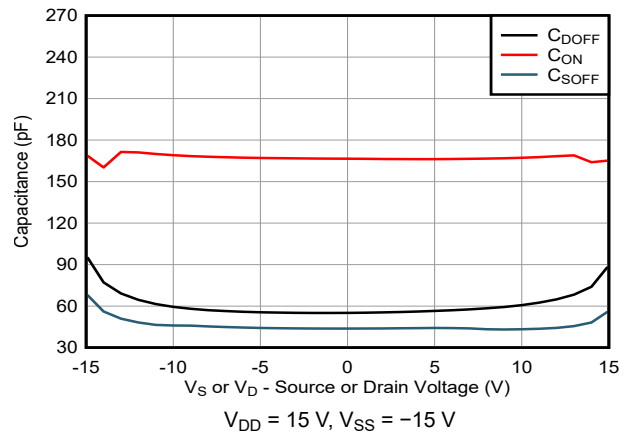

5-24. Capacitance vs Source or Drain Voltage

5.14 Typical Characteristics (continued)

at $T_A = 25^\circ\text{C}$ (unless otherwise noted)



图 5-25. Capacitance vs Source or Drain Voltage



图 5-26. THD+N vs Frequency – Single Supply

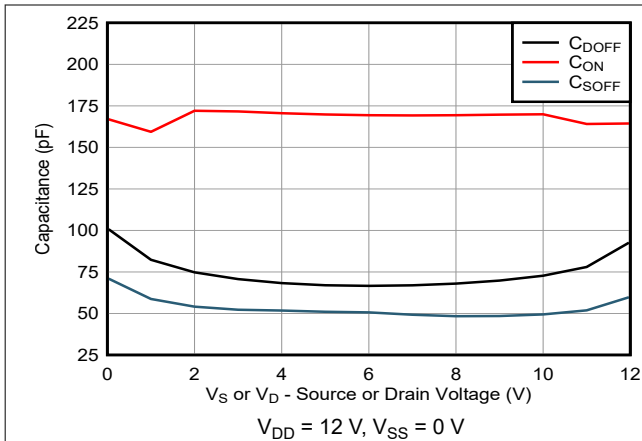

图 5-27. THD+N vs Frequency – Dual Supply

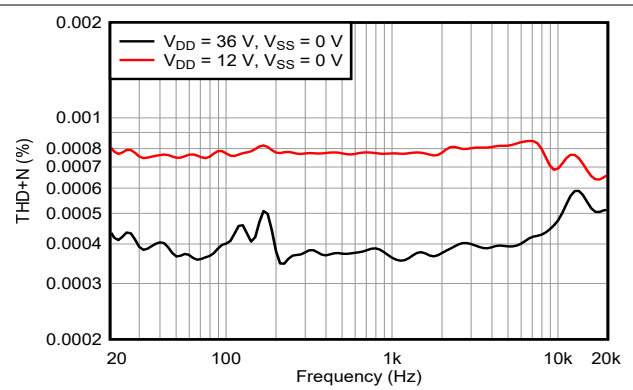

图 5-28. ACPSRR vs Frequency

6 Parameter Measurement Information

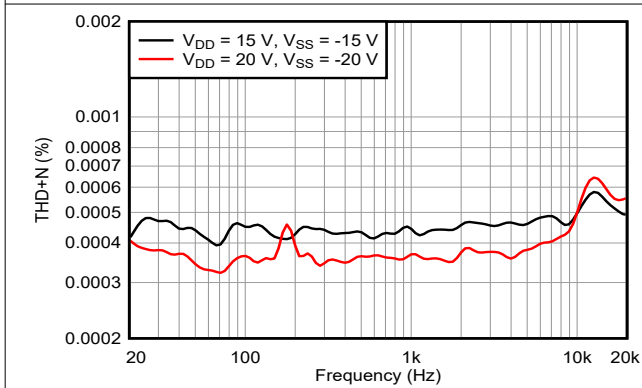
6.1 On-Resistance

The on-resistance of a device is the ohmic resistance between the source (Sx) and drain (D) pins of the device. The on-resistance varies with input voltage and supply voltage. The symbol R_{ON} is used to denote on-resistance. Figure 6-1 shows the measurement setup used to measure R_{ON} . Voltage (V) and current (I_{SD}) are measured using this setup, and R_{ON} is computed with $R_{ON} = V / I_{SD}$.

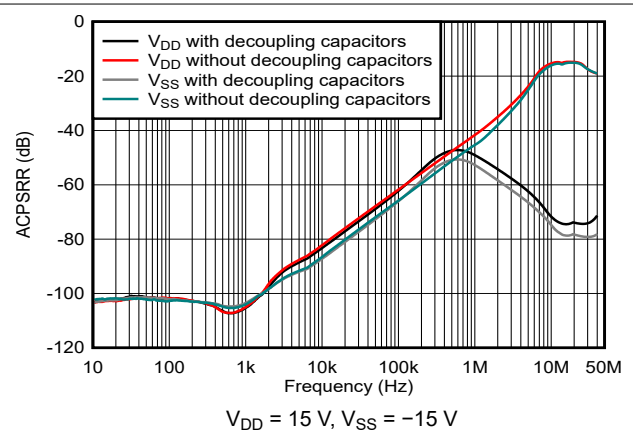
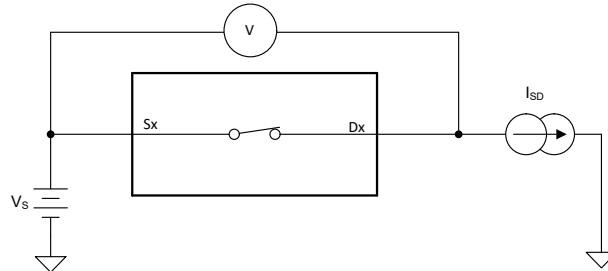

Figure 6-1. On-Resistance Measurement Setup

6.2 Off-Leakage Current

There are two types of leakage currents associated with a switch during the off state:

- Source off-leakage current
- Drain off-leakage current

Source leakage current is defined as the leakage current flowing into or out of the source pin when the switch is off. This current is denoted by the symbol $I_{S(OFF)}$.

Drain leakage current is defined as the leakage current flowing into or out of the drain pin when the switch is off. This current is denoted by the symbol $I_{D(OFF)}$.

Figure 6-2 shows the setup used to measure both off-leakage currents.

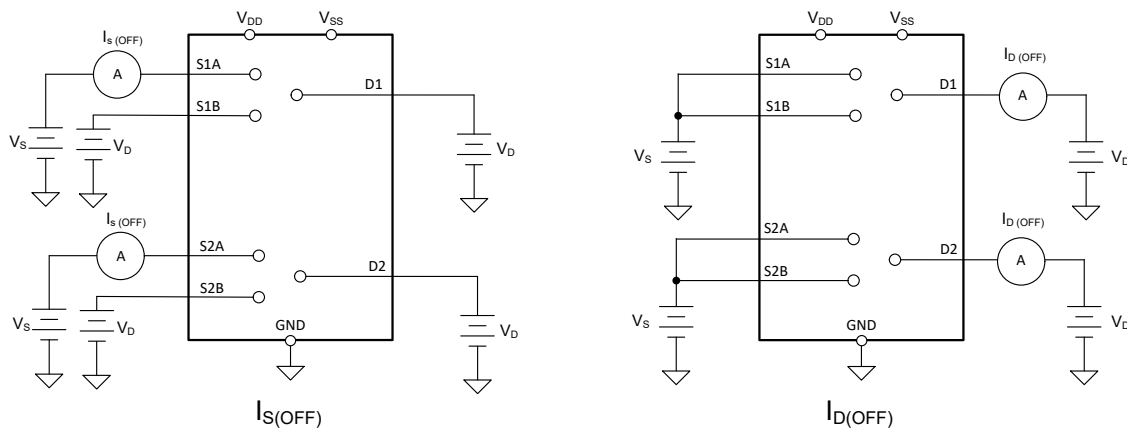
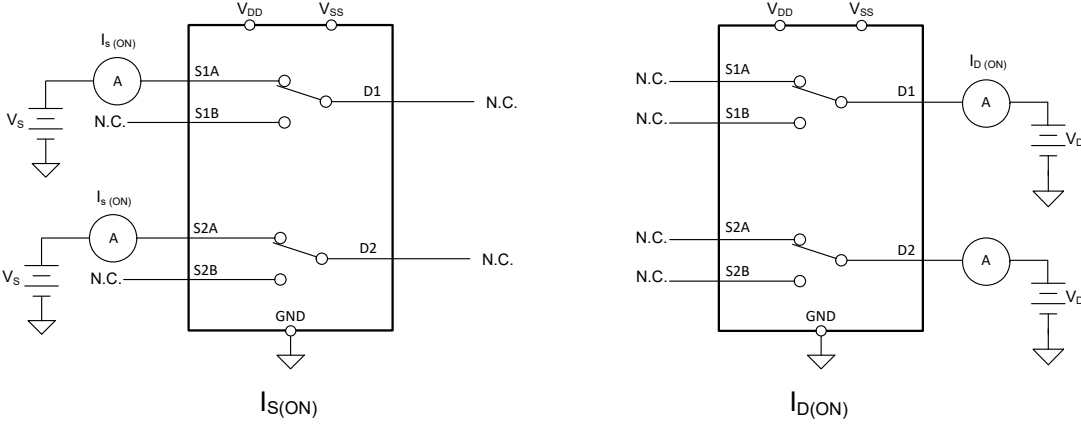

Figure 6-2. Off-Leakage Measurement Setup

6.3 On-Leakage Current

Source on-leakage current is defined as the leakage current flowing into or out of the source pin when the switch is on. This current is denoted by the symbol $I_{S(ON)}$.

Drain on-leakage current is defined as the leakage current flowing into or out of the drain pin when the switch is on. This current is denoted by the symbol $I_{D(ON)}$.

Either the source pin or drain pin is left floating during the measurement.  6-3 shows the circuit used for measuring the on-leakage current, denoted by $I_{S(ON)}$ or $I_{D(ON)}$.

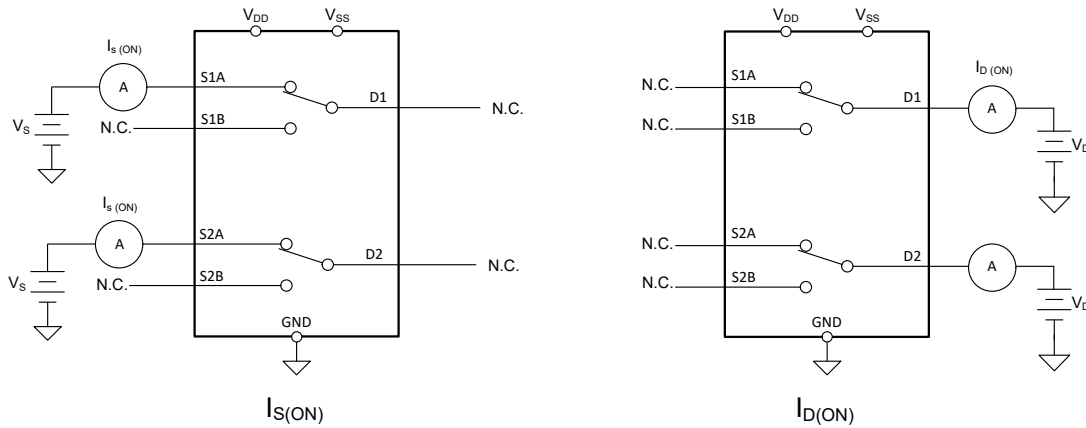

 6-3. On-Leakage Measurement Setup

6.4 Transition Time

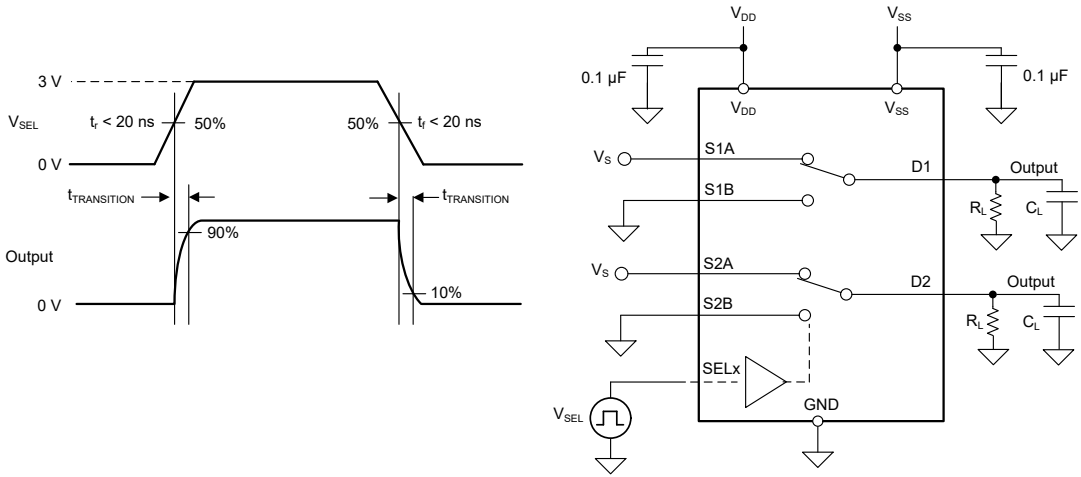
Transition time is defined as the time taken by the output of the device to rise or fall 90% after the address signal has risen or fallen past the logic threshold. The 90% transition measurement is utilized to provide the timing of the device. System level timing can then account for the time constant added from the load resistance and load capacitance.  6-4 shows the setup used to measure transition time, denoted by the symbol $t_{TRANSITION}$.

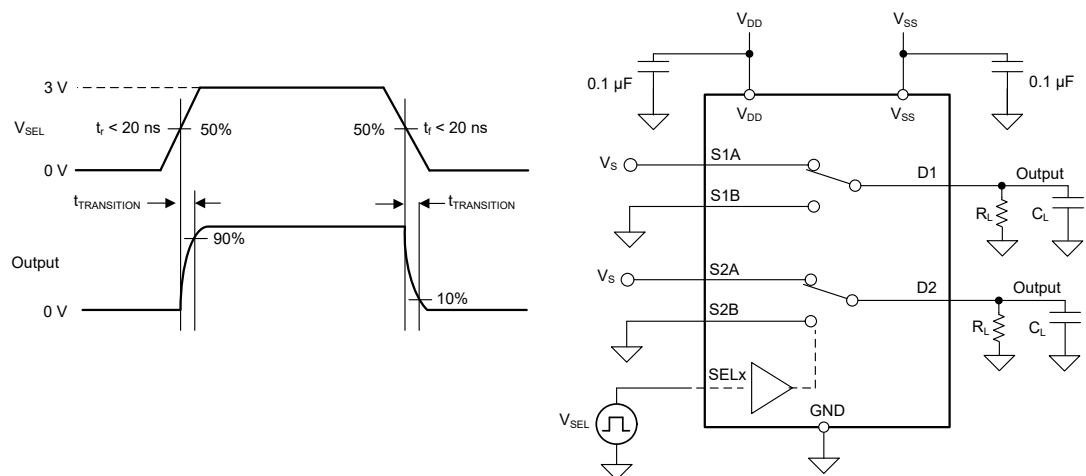

 6-4. Transition-Time Measurement Setup

6.5 $t_{ON(EN)}$ and $t_{OFF(EN)}$

Turn-on time is defined as the time taken by the output of the device to rise to 90% after the enable has risen past the logic threshold. The 90% measurement is utilized to provide the timing of the device. System level timing can then account for the time constant added from the load resistance and load capacitance. [Figure 6-5](#) shows the setup used to measure turn-on time, denoted by the symbol $t_{ON(EN)}$.

Turn-off time is defined as the time taken by the output of the device to fall to 10% after the enable has fallen past the logic threshold. The 10% measurement is utilized to provide the timing of the device. System level timing can then account for the time constant added from the load resistance and load capacitance. [Figure 6-5](#) shows the setup used to measure turn-off time, denoted by the symbol $t_{OFF(EN)}$.

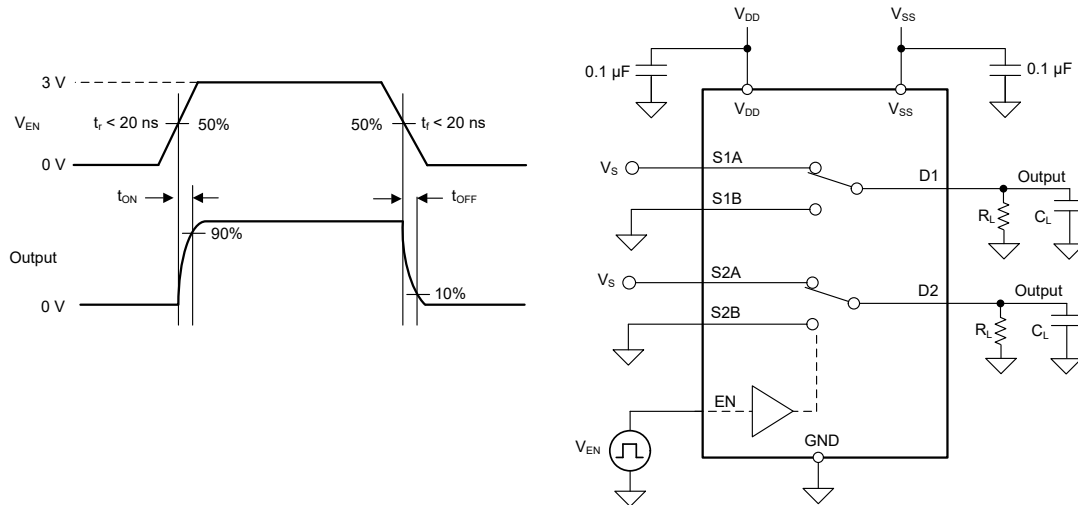

Figure 6-5. Turn-On and Turn-Off Time Measurement Setup

6.6 Break-Before-Make

Break-before-make delay is a safety feature that prevents two inputs from connecting when the device is switching. The output first breaks from the on-state switch before making the connection with the next on-state switch. The time delay between the *break* and the *make* is known as break-before-make delay. [Figure 6-6](#) shows the setup used to measure break-before-make delay, denoted by the symbol $t_{OPEN(BBM)}$.

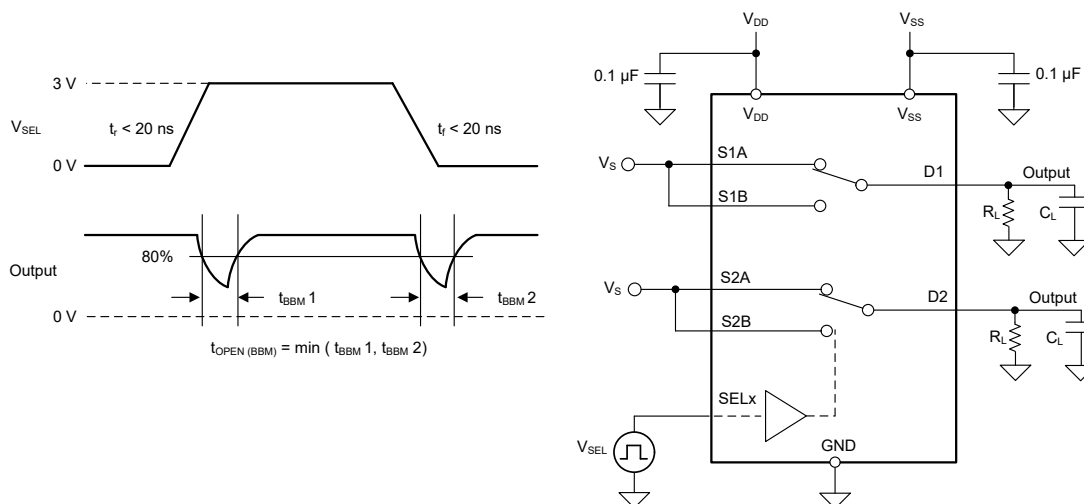
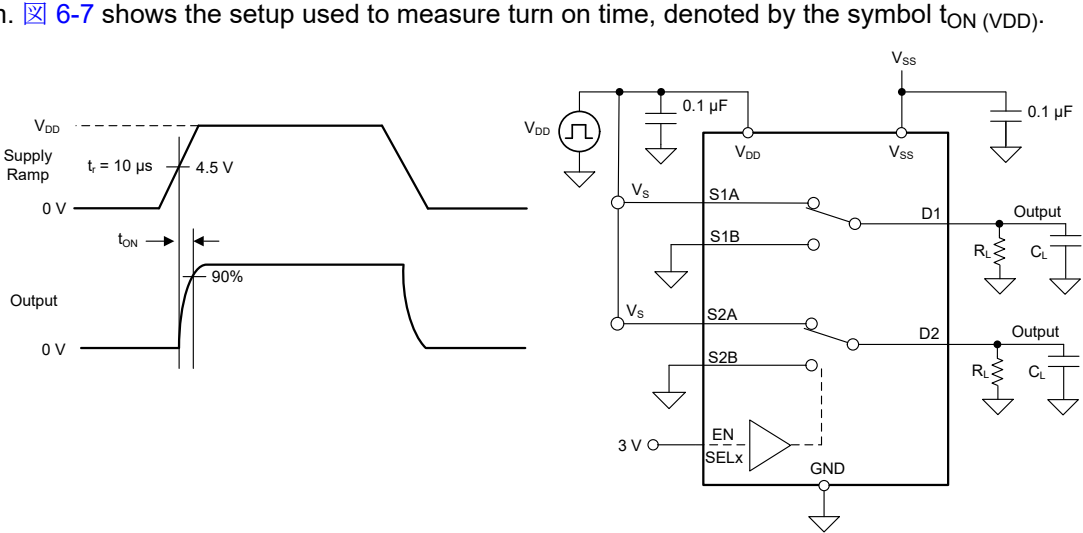

Figure 6-6. Break-Before-Make Delay Measurement Setup

6.7 $t_{ON(VDD)}$ Time

The $t_{ON(VDD)}$ time is defined as the time taken by the output of the device to rise to 90% after the supply has risen past the supply threshold. The 90% measurement is used to provide the timing of the device turning on in the system.  shows the setup used to measure turn on time, denoted by the symbol $t_{ON(VDD)}$.



図 6-7. $t_{ON(VDD)}$ Time Measurement Setup

6.8 Propagation Delay

Propagation delay is defined as the time taken by the output of the device to rise or fall 50% after the input signal has risen or fallen past the 50% threshold.  shows the setup used to measure propagation delay, denoted by the symbol t_{PD} .

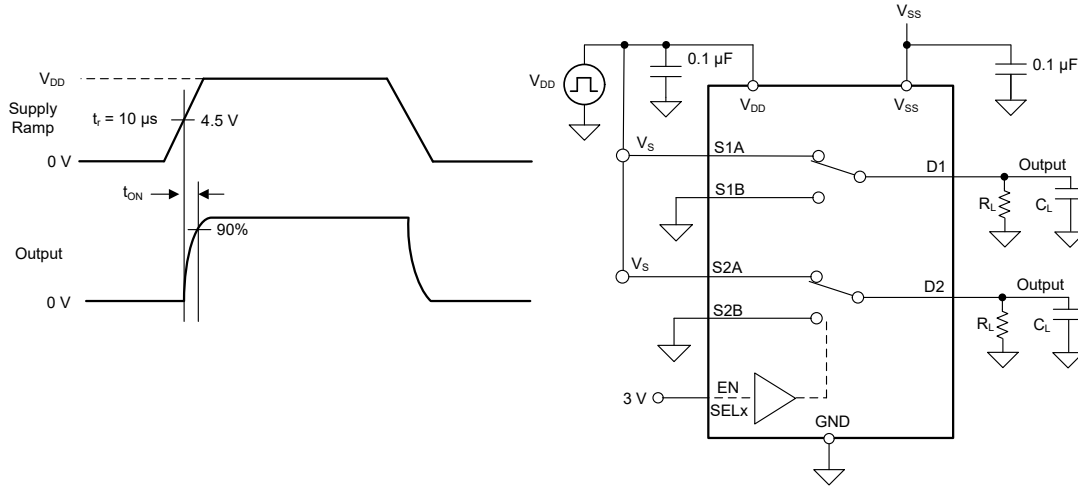
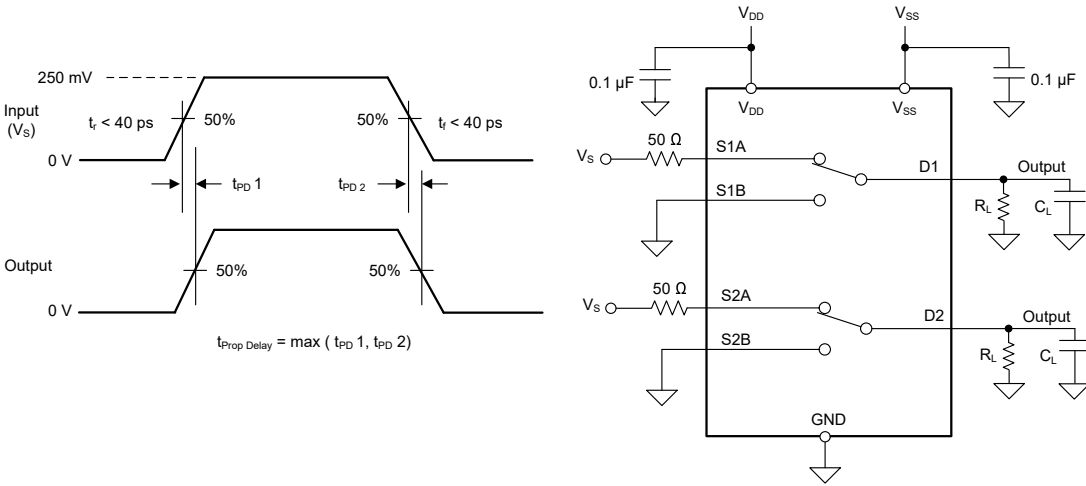

図 6-8. Propagation Delay Measurement Setup

6.9 Charge Injection

The TMUX7236 has a transmission-gate topology. Any mismatch in capacitance between the NMOS and PMOS transistors results in a charge injected into the drain or source during the falling or rising edge of the gate signal. The amount of charge injected into the source or drain of the device is known as charge injection, and is denoted by the symbol Q_{INJ} . 6-9 shows the setup used to measure charge injection from source (Sx) to drain (D).

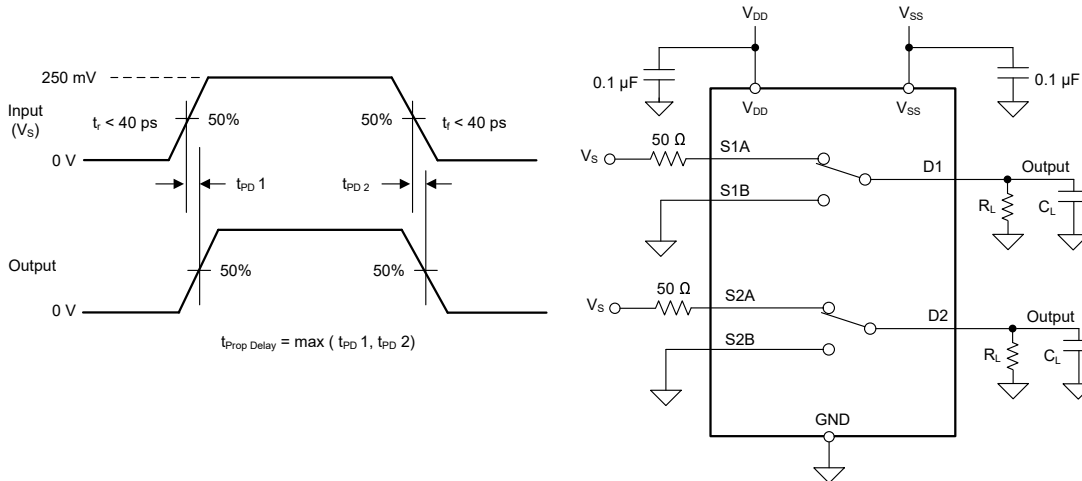
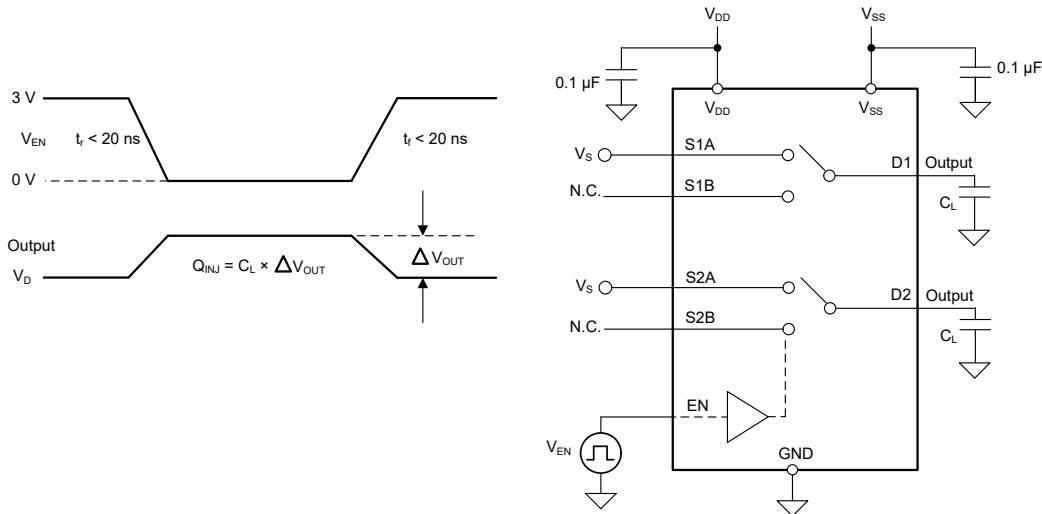

6-9. Charge-Injection Measurement Setup

6.10 Off Isolation

Off isolation is defined as the ratio of the signal at the drain pin (D) of the device when a signal is applied to the source pin (Sx) of an off-channel. 6-10 shows the setup used to measure, and the equation used to calculate off isolation.

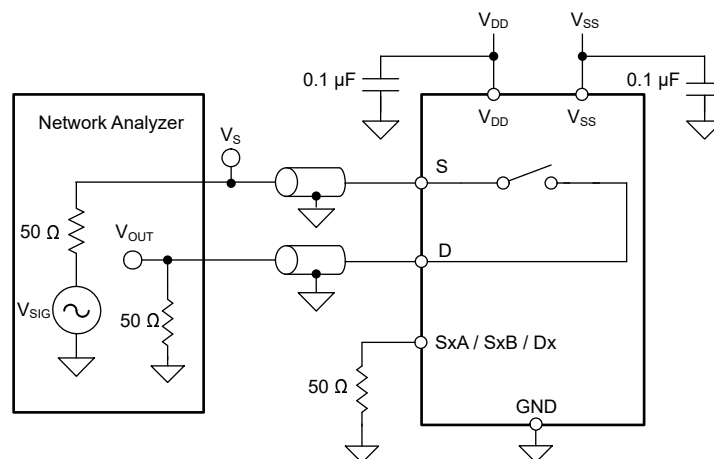

6-10. Off Isolation Measurement Setup

6.11 Crosstalk

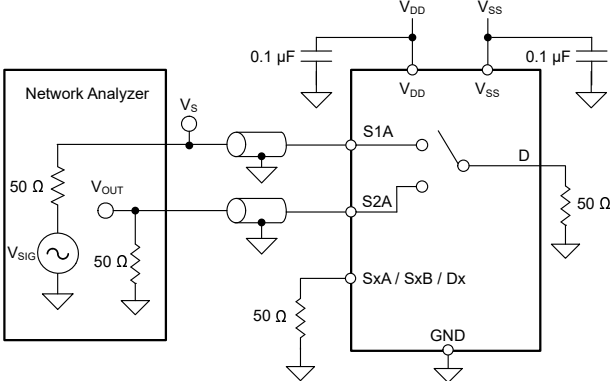
Crosstalk is defined as the ratio of the signal at the drain pin (D) of a different channel, when a signal is applied at the source pin (Sx) of an on-channel.  shows the setup used to measure and the equation used to calculate crosstalk.

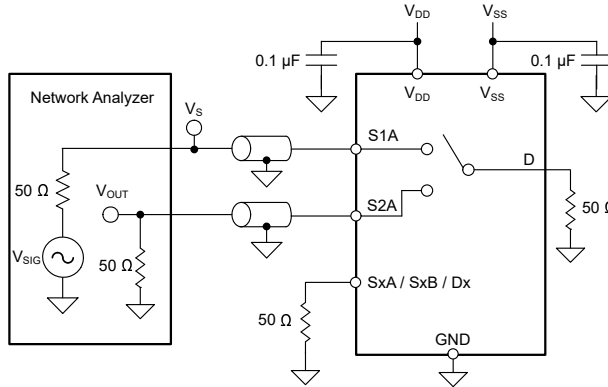

 **6-11. Crosstalk Measurement Setup**

6.12 Bandwidth

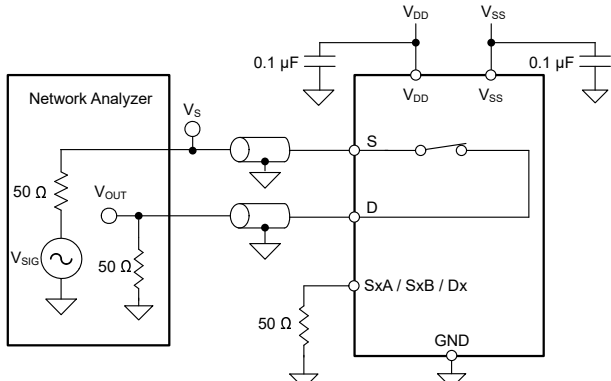
Bandwidth is defined as the range of frequencies that are attenuated by less than 3 dB when the input is applied to the source pin (Sx) of an on-channel, and the output is measured at the drain pin (D) of the device.  shows the setup used to measure bandwidth.

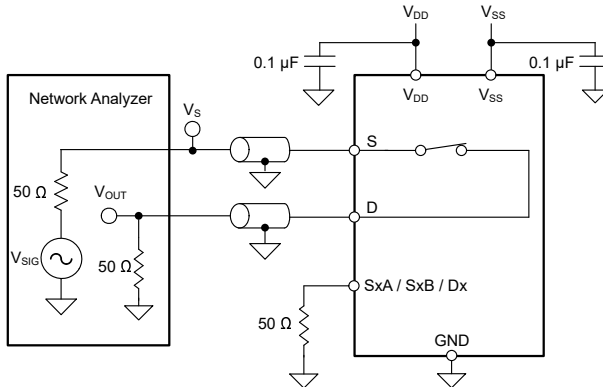

 **6-12. Bandwidth Measurement Setup**

6.13 THD + Noise

The total harmonic distortion (THD) of a signal is a measurement of the harmonic distortion, and is defined as the ratio of the sum of the powers of all harmonic components to the power of the fundamental frequency at the mux output. The on-resistance of the device varies with the amplitude of the input signal and results in distortion when the drain pin is connected to a low-impedance load. Total harmonic distortion plus noise is denoted as THD.

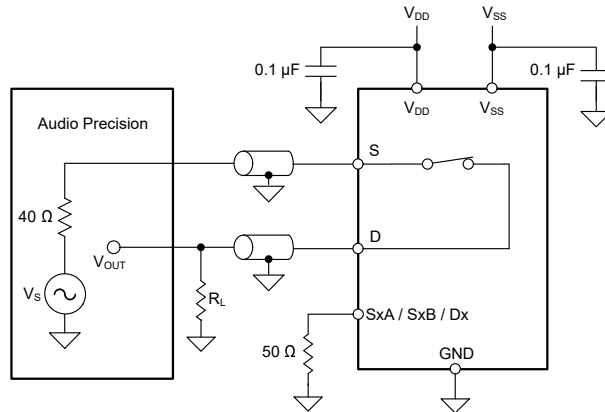

6-13. THD Measurement Setup

6.14 Power Supply Rejection Ratio (PSRR)

PSRR measures the ability of a device to prevent noise and spurious signals that appear on the supply voltage pin from coupling to the output of the switch. The DC voltage on the device supply is modulated by a sine wave of 620 mVPP. The ratio of the amplitude of signal on the output to the amplitude of the modulated signal is the ACPSRR. A high ratio represents a high degree of tolerance to supply rail variation.

6-14 shows how the decoupling capacitors reduce high frequency noise on the supply pins. This helps stabilize the supply and immediately filter as much of the supply noise as possible.

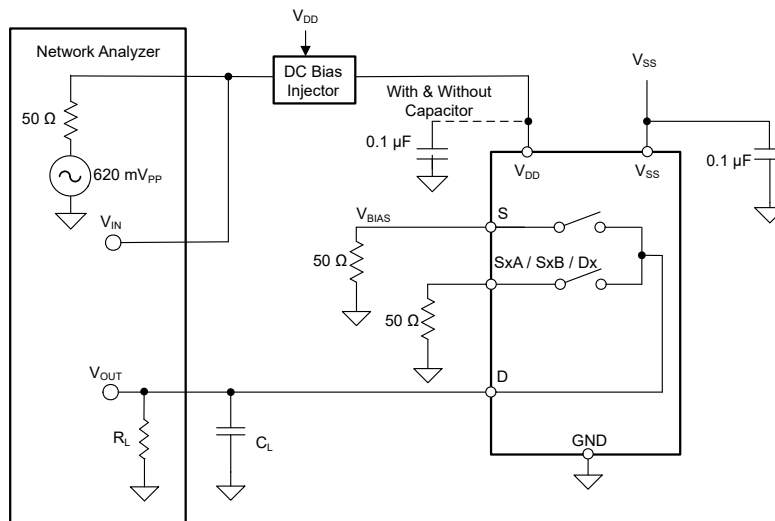

6-14. ACPSRR Measurement Setup

7 Detailed Description

7.1 Functional Block Diagram

The TMUX7236 is a 2:1, 2-channel multiplexer or demultiplexer. Each input is turned on or turned off based on the state of the select lines and enable pin.

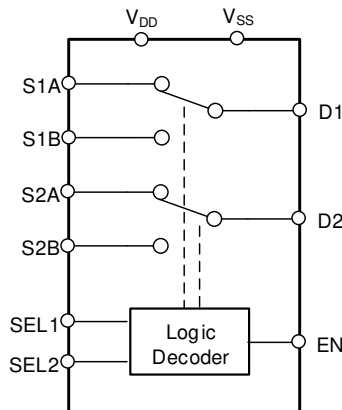

7.2 Feature Description

7.2.1 Bidirectional Operation

The TMUX7236 conducts equally well from source (S_x) to drain (D_x) or from drain (D_x) to source (S_x). Each channel has very similar characteristics in both directions and supports both analog and digital signals.

7.2.2 Rail to Rail Operation

The valid signal path input or output voltage for TMUX7236 ranges from V_{SS} to V_{DD} .

7.2.3 1.8 V Logic Compatible Inputs

The TMUX7236 has 1.8-V logic compatible control for all logic control inputs. 1.8-V logic level inputs allows the TMUX7236 to interface with processors that have lower logic I/O rails and eliminates the need for an external translator, which saves both space and bill of materials (BOM) cost. For more information on 1.8 V logic implementations, refer to [Simplifying Design with 1.8 V logic Muxes and Switches](#).

7.2.4 Integrated Pull-Down Resistor on Logic Pins

The TMUX7236 has internal weak pull-down resistors to GND so that the logic pins are not left floating. The value of this pull-down resistor is approximately 4 M Ω , but is clamped to about 1 μ A at higher voltages. This feature integrates up to three external components and reduces system size and cost.

7.2.5 Fail-Safe Logic

The TMUX7236 supports Fail-Safe Logic on the control input pins (EN and SEL) allowing the device to operate up to 44 V above V_{SS} , regardless of the state of the supply pins. This feature allows voltages on the control pins to be applied before the supply pin, protecting the device from potential damage. Fail-Safe Logic minimizes system complexity by removing the need for power supply sequencing on the logic control pins. For example, the Fail-Safe Logic feature allows the logic input pins of the TMUX7236 to be ramped to +44 V while V_{DD} and $V_{SS} = 0$ V. The logic control inputs are protected against positive faults of up to +44 V in the powered-off condition, but does not offer protection against negative overvoltage conditions.

7.2.6 Latch-Up Immune

Latch-up is a condition where a low impedance path is created between a supply pin and ground. The latch-up condition is caused by a trigger (current injection or overvoltage); but once activated, the low impedance path remains even after the trigger is no longer present. This low impedance path may cause system upset or catastrophic damage due to excessive current levels. The latch-up condition typically requires a power cycle to eliminate the low impedance path.

The TMUX7236 is constructed on silicon on insulator (SOI) based process where an oxide layer is added between the PMOS and NMOS transistor of each CMOS switch to prevent parasitic structures from forming. The oxide layer is also known as an insulating trench and prevents triggering of latch up events due to overvoltage or current injections. The latch-up immunity feature allows the TMUX7236 to be used in harsh environments. For more information on latch-up immunity, refer to [Using Latch Up Immune Multiplexers to Help Improve System Reliability](#).

7.2.7 Ultra-Low Charge Injection

Figure 7-1 shows how the TMUX7236 device has a transmission gate topology. Any mismatch in the stray capacitance associated with the NMOS and PMOS causes an output level change whenever the switch is opened or closed.

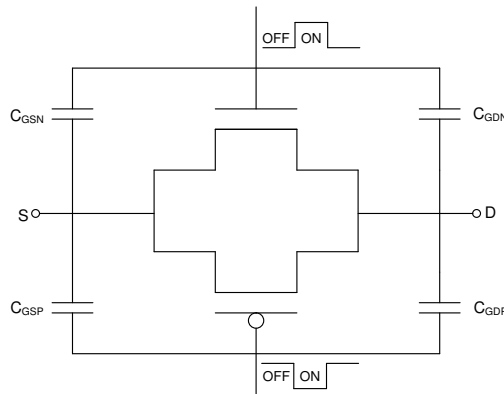

Figure 7-1. Transmission Gate Topology

The TMUX7236 contains specialized architecture to reduce charge injection on the Drain (Dx). To further reduce charge injection in a sensitive application, a compensation capacitor (Cp) can be added on the Source (Sx). This will push excess charge from the switch transition into the compensation capacitor on the Source (Sx) instead of the Drain (Dx). As a general rule, Cp should be 20x larger than the equivalent load capacitance on the Drain (Dx). Figure 7-2 shows charge injection variation with different compensation capacitors on the Source side. Figure 7-2 was captured on the TMUX7219 as part of the TMUX72xx family with a 100 pF load capacitance.

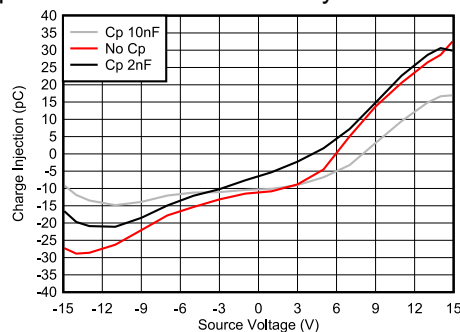

Figure 7-2. Charge Injection Compensation

7.3 Device Functional Modes

When the EN pin of the TMUX7236 is pulled high, one of the switches is closed based on the state of the SEL pin. When the EN pin is pulled low, both of the switches are in an open state regardless of the state of the SEL pin. The control pins can be as high as 44 V.

7.4 Truth Tables

表 7-1 show the truth tables for the TMUX7236.

表 7-1. TMUX7236 Truth Table

EN	SELx	Selected Input Connected To Drain (D) Pin
0	X ⁽¹⁾	All channels are off (Hi-Z)
1	0	SxB
1	1	SxA

(1) X denotes *do not care*.

8 Application and Implementation

注

以下のアプリケーション情報は、テキサス・インスツルメンツの製品仕様に含まれるものではなく、テキサス・インスツルメンツはその正確性も完全性も保証いたしません。個々の目的に対する製品の適合性については、お客様の責任で判断していただくことになります。また、お客様は自身の設計実装を検証しテストすることで、システムの機能を確認する必要があります。

8.1 Application Information

The TMUX7236 is part of the precision switches and multiplexers family of devices. This device operates with dual supplies ($\pm 4.5\text{ V}$ to $\pm 22\text{ V}$), a single supply (4.5 V and 44 V), or asymmetric supplies (such as, $V_{DD} = 12\text{ V}$ and $V_{SS} = -5\text{ V}$), and offers rail-to-rail input and output. The TMUX7236 offers low R_{ON} , low on and off leakage currents and ultra-low charge injection performance. These features makes the TMUX7236 a precision, robust, high-performance analog multiplexer for high-voltage, industrial applications.

8.2 Typical Application

One application for the TMUX7236 is in data acquisition systems. For these types of input modules, accuracy and precision is key. To help account for drift over time and temperature, a calibration path is often added to calibrate the input in real time before a measurement. An SPDT switch can be used to switch in this calibration path, which the TMUX7236 is an excellent choice for. This device offers a very low on-resistance, leakage, and charge injection, which allows for a high measurement fidelity and reduces error. The break-before-make feature allows switching from the calibration path without shorting the inputs together. This device also offers on-resistance mismatch, which makes this device suitable for high precision systems. As [図 8-1](#) shows, the TMUX7236 can be used in both voltage and current acquisition.



図 8-1. Data Acquisition Systems (DAQ) Calibration

8.2.1 Design Requirements

For this design example, use the parameters listed in [表 8-1](#).

表 8-1. Design Parameters

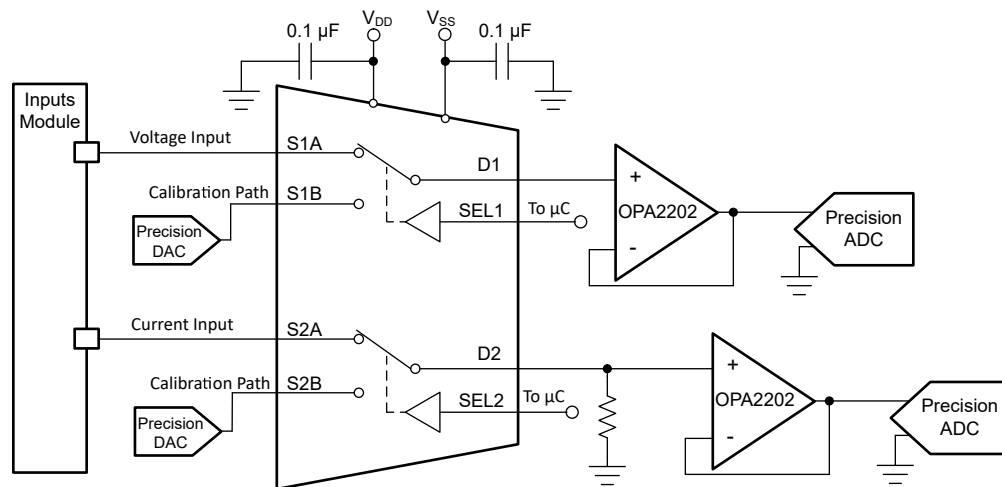
PARAMETERS	VALUES
Supply (V_{DD})	15 V
Supply (V_{SS})	-15 V
MUX I/O signal range	-15 V to 15 V (Rail-to-Rail)
Control logic thresholds	1.8 V compatible (up to V_{DD})
EN	EN pulled high to enable the switch

8.2.2 Detailed Design Procedure

The TMUX7236 can operate without any external components except for the supply decoupling capacitors. All inputs passing through the switch must fall within the recommended operating conditions of the TMUX7236, including signal range and continuous current. The signal range for this design can be up to -15 V to +15 V and the maximum continuous current can be up to 330 mA for wide-range current measurement with a positive supply of 15 V on V_{DD} and negative supply of -15 V on V_{SS} (for more information, see [セクション 5.4](#)). The TMUX7236 device is a bidirectional, single-pole double-throw (SPDT) switch that offers low on-resistance, low leakage, and low power. These features make this device suitable for precision and power sensitive applications.

8.2.3 Application Curve

The low on-resistance of TMUX7236 and ultra-low charge injection performance make this device ideal for implementing high precision systems. [図 8-2](#) shows the plot for the on-resistance versus temperature. Additionally, the TMUX7236 features a very low mismatch between channels, which is important for this application because it reduces the difference between the calibration and non-calibration paths. The TMUX7236 features mismatch between channels <180 mΩ and 100 mΩ typically.



図 8-2. On-Resistance vs Temperature

8.2.3.1 On-Resistance Mismatch Between Channels

$V_{DD} = +15\text{ V} \pm 10\%$, $V_{SS} = -15\text{ V} \pm 10\%$, GND = 0 V (unless otherwise noted)

Typical at $V_{DD} = +15\text{ V}$, $V_{SS} = -15\text{ V}$, $T_A = 25^\circ\text{C}$ (unless otherwise noted)

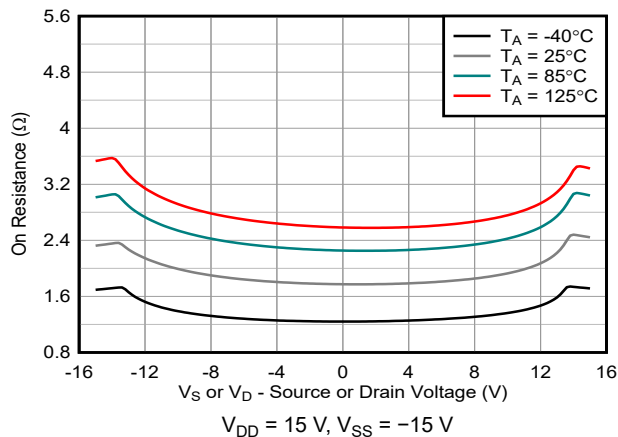
PARAMETER		TEST CONDITIONS	T_A	MIN	TYP	MAX	UNIT
ΔR_{ON}	On-resistance mismatch between channels	$V_S = -10\text{ V to }+10\text{ V}$ $I_D = -10\text{ mA}$ Refer to On-Resistance	25°C		0.1	0.18	Ω
			-40°C to +85°C			0.19	Ω
			-40°C to +125°C			0.21	Ω

8.3 Power Supply Recommendations

The TMUX7236 operates across a wide supply range of $\pm 4.5\text{ V}$ to $\pm 22\text{ V}$ (4.5 V to 44 V in single-supply mode). The device also performs well with asymmetrical supplies such as $V_{DD} = 12\text{ V}$ and $V_{SS} = -5\text{ V}$.

Power-supply bypassing improves noise margin and prevents switching noise propagation from the supply rails to other components. Good power-supply decoupling is important to achieve optimum performance. For improved supply noise immunity, use a supply decoupling capacitor ranging from 0.1 μF to 10 μF at both the V_{DD} and V_{SS} pins to ground. Place the bypass capacitors as close to the power supply pins of the device as possible using low-impedance connections. TI recommends using multi-layer ceramic chip capacitors (MLCCs) that offer low equivalent series resistance (ESR) and inductance (ESL) characteristics for power-supply decoupling purposes. For very sensitive systems, or for systems in harsh noise environments, avoiding the use of vias for connecting the capacitors to the device pins may offer superior noise immunity. The use of multiple vias in parallel lowers the overall inductance and is beneficial for connections to ground planes. Always ensure the ground (GND) connection is established before supplies are ramped.

8.4 Layout

8.4.1 Layout Guidelines

When a PCB trace turns a corner at a 90° angle, a reflection can occur. A reflection occurs primarily because of the change of width of the trace. At the apex of the turn, the trace width increases to 1.414 times the width. This increase upsets the transmission-line characteristics, especially the distributed capacitance and self-inductance of the trace which results in the reflection. Not all PCB traces can be straight and therefore some traces must turn corners. [Figure 8-3](#) shows progressively better techniques of rounding corners. Only the last example (BEST) maintains constant trace width and minimizes reflections.

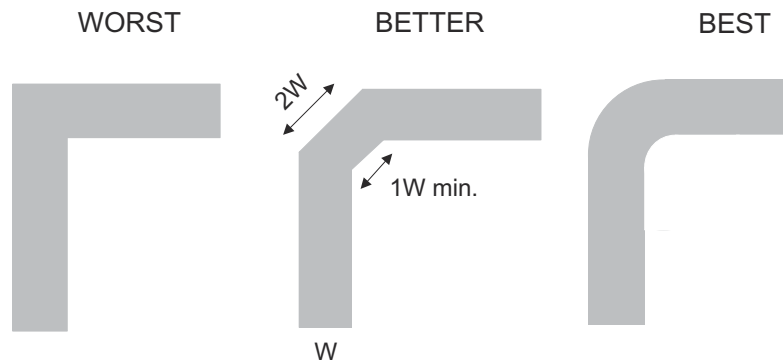

Figure 8-3. Trace Example

Route high-speed signals using a minimum of vias and corners which reduces signal reflections and impedance changes. When a via must be used, increase the clearance size around it to minimize its capacitance. Each via introduces discontinuities in the signal's transmission line and increases the chance of picking up interference from the other layers of the board. Be careful when designing test points, through-hole pins are not recommended at high frequencies.

Some key considerations are as follows:

- For reliable operation, connect a decoupling capacitor ranging from 0.1 μF to 10 μF between V_{DD}/V_{SS} and GND. TI recommends a 0.1- μF and 1- μF capacitor, placing the lowest value capacitor as close to the pin as possible. Make sure that the capacitor voltage rating is sufficient for the supply voltage.
- Keep the input lines as short as possible.
- Use a solid ground plane to help reduce electromagnetic interference (EMI) noise pickup.
- Do not run sensitive analog traces in parallel with digital traces. Avoid crossing digital and analog traces if possible, and only make perpendicular crossings when necessary.
- Using multiple vias in parallel will lower the overall inductance and is beneficial for connection to ground planes.

8.4.2 Layout Example



図 8-4. TMUX7236RUM Layout Example



図 8-5. TMUX7236PW Layout Example

9 Device and Documentation Support

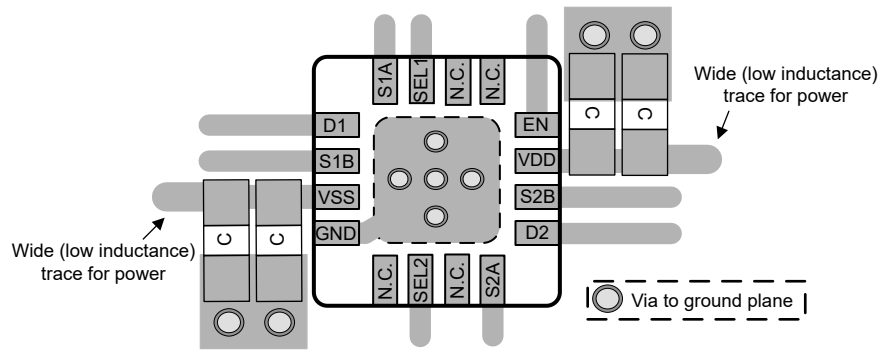
9.1 Documentation Support

9.1.1 Related Documentation

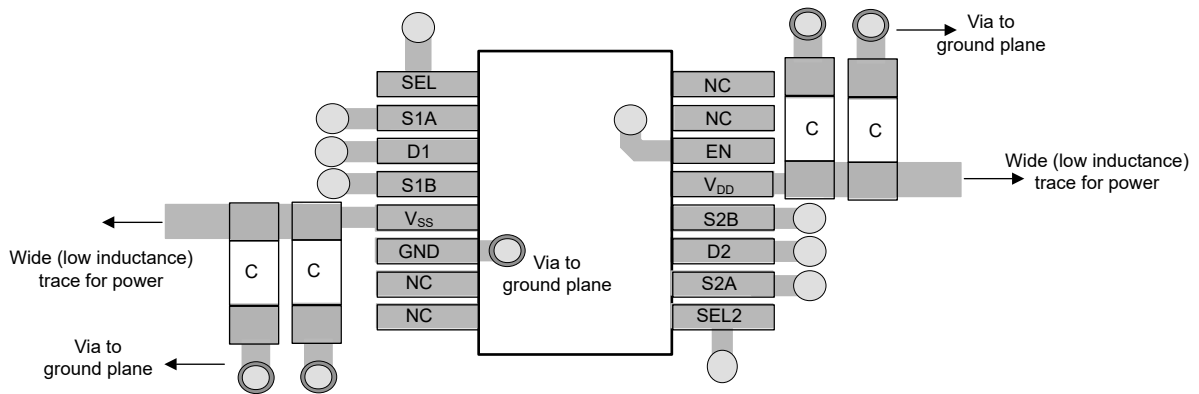
For related documentation, see the following:

- Texas Instruments, [Eliminate Power Sequencing with Powered-off Protection Signal Switches](#)
- Texas Instruments, [Improve Stability Issues with Low CON Multiplexers](#)
- Texas Instruments, [QFN/SON PCB Attachment](#)
- Texas Instruments, [Quad Flatpack No-Lead Logic Packages](#)
- Texas Instruments, [Simplifying Design with 1.8 V logic Muxes and Switches](#)
- Texas Instruments, [System-Level Protection for High-Voltage Analog Multiplexers](#)
- Texas Instruments, [True Differential, 4 x 2 MUX, Analog Front End, Simultaneous-Sampling ADC Circuit](#)

9.2 ドキュメントの更新通知を受け取る方法

ドキュメントの更新についての通知を受け取るには、www.tij.co.jp のデバイス製品フォルダを開いてください。[通知] をクリックして登録すると、変更されたすべての製品情報に関するダイジェストを毎週受け取ることができます。変更の詳細については、改訂されたドキュメントに含まれている改訂履歴をご覧ください。

9.3 サポート・リソース

テキサス・インスツルメンツ E2E™ サポート・フォーラムは、エンジニアが検証済みの回答と設計に関するヒントをエキスパートから迅速かつ直接得ることができる場所です。既存の回答を検索したり、独自の質問をしたりすることで、設計に必要な支援を迅速に得ることができます。

リンクされているコンテンツは、各寄稿者により「現状のまま」提供されるものです。これらはテキサス・インスツルメンツの仕様を構成するものではなく、必ずしもテキサス・インスツルメンツの見解を反映したものではありません。テキサス・インスツルメンツの[使用条件](#)を参照してください。

9.4 Trademarks

テキサス・インスツルメンツ E2E™ is a trademark of Texas Instruments.

すべての商標は、それぞれの所有者に帰属します。

9.5 用語集

[テキサス・インスツルメンツ用語集](#) この用語集には、用語や略語の一覧および定義が記載されています。

9.6 静電気放電に関する注意事項



この IC は、ESD によって破損する可能性があります。テキサス・インスツルメンツは、IC を取り扱う際には常に適切な注意を払うことを推奨します。正しい取り扱いおよび設置手順に従わない場合、デバイスを破損するおそれがあります。

ESD による破損は、わずかな性能低下からデバイスの完全な故障まで多岐にわたります。精密な IC の場合、パラメータがわずかに変化するだけで公表されている仕様から外れる可能性があるため、破損が発生しやすくなっています。

10 Revision History

資料番号末尾の英字は改訂を表しています。その改訂履歴は英語版に準じています。

Changes from Revision A (July 2022) to Revision B (December 2023)	Page
• PW パッケージ情報を追加.....	1

Changes from Revision * (March 2022) to Revision A (July 2022)	Page
• データシートのステータスを以下のように変更:「事前情報」から「量産データ」.....	1

11 Mechanical, Packaging, and Orderable Information

The following pages include mechanical, packaging, and orderable information. This information is the most current data available for the designated devices. This data is subject to change without notice and revision of this document. For browser-based versions of this data sheet, refer to the left-hand navigation.

PACKAGING INFORMATION

Orderable part number	Status (1)	Material type (2)	Package Pins	Package qty Carrier	RoHS (3)	Lead finish/ Ball material (4)	MSL rating/ Peak reflow (5)	Op temp (°C)	Part marking (6)
TMUX7236PWR	Active	Production	TSSOP (PW) 16	2000 LARGE T&R	Yes	NIPDAU	Level-1-260C-UNLIM	-40 to 125	T236
TMUX7236PWR.B	Active	Production	TSSOP (PW) 16	2000 LARGE T&R	Yes	NIPDAU	Level-1-260C-UNLIM	-40 to 125	T236
TMUX7236RUMR	Active	Production	WQFN (RUM) 16	3000 LARGE T&R	Yes	NIPDAU	Level-1-260C-UNLIM	-40 to 125	TMUX T236
TMUX7236RUMR.B	Active	Production	WQFN (RUM) 16	3000 LARGE T&R	Yes	NIPDAU	Level-1-260C-UNLIM	-40 to 125	TMUX T236

(1) **Status:** For more details on status, see our [product life cycle](#).

(2) **Material type:** When designated, preproduction parts are prototypes/experimental devices, and are not yet approved or released for full production. Testing and final process, including without limitation quality assurance, reliability performance testing, and/or process qualification, may not yet be complete, and this item is subject to further changes or possible discontinuation. If available for ordering, purchases will be subject to an additional waiver at checkout, and are intended for early internal evaluation purposes only. These items are sold without warranties of any kind.

(3) **RoHS values:** Yes, No, RoHS Exempt. See the [TI RoHS Statement](#) for additional information and value definition.

(4) **Lead finish/Ball material:** Parts may have multiple material finish options. Finish options are separated by a vertical ruled line. Lead finish/Ball material values may wrap to two lines if the finish value exceeds the maximum column width.

(5) **MSL rating/Peak reflow:** The moisture sensitivity level ratings and peak solder (reflow) temperatures. In the event that a part has multiple moisture sensitivity ratings, only the lowest level per JEDEC standards is shown. Refer to the shipping label for the actual reflow temperature that will be used to mount the part to the printed circuit board.

(6) **Part marking:** There may be an additional marking, which relates to the logo, the lot trace code information, or the environmental category of the part.

Multiple part markings will be inside parentheses. Only one part marking contained in parentheses and separated by a "-" will appear on a part. If a line is indented then it is a continuation of the previous line and the two combined represent the entire part marking for that device.

Important Information and Disclaimer: The information provided on this page represents TI's knowledge and belief as of the date that it is provided. TI bases its knowledge and belief on information provided by third parties, and makes no representation or warranty as to the accuracy of such information. Efforts are underway to better integrate information from third parties. TI has taken and continues to take reasonable steps to provide representative and accurate information but may not have conducted destructive testing or chemical analysis on incoming materials and chemicals. TI and TI suppliers consider certain information to be proprietary, and thus CAS numbers and other limited information may not be available for release.

In no event shall TI's liability arising out of such information exceed the total purchase price of the TI part(s) at issue in this document sold by TI to Customer on an annual basis.

TAPE AND REEL INFORMATION

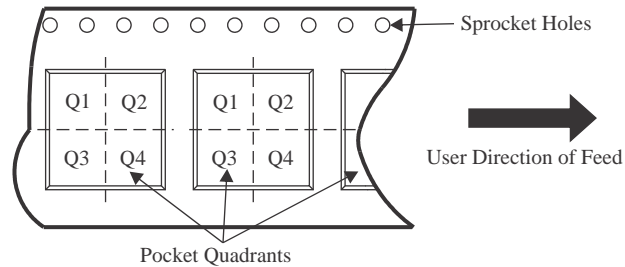
QUADRANT ASSIGNMENTS FOR PIN 1 ORIENTATION IN TAPE

*All dimensions are nominal

Device	Package Type	Package Drawing	Pins	SPQ	Reel Diameter (mm)	Reel Width W1 (mm)	A0 (mm)	B0 (mm)	K0 (mm)	P1 (mm)	W (mm)	Pin1 Quadrant
TMUX7236PWR	TSSOP	PW	16	2000	330.0	12.4	6.9	5.6	1.6	8.0	12.0	Q1
TMUX7236RUMR	WQFN	RUM	16	3000	330.0	12.4	4.25	4.25	1.15	8.0	12.0	Q2

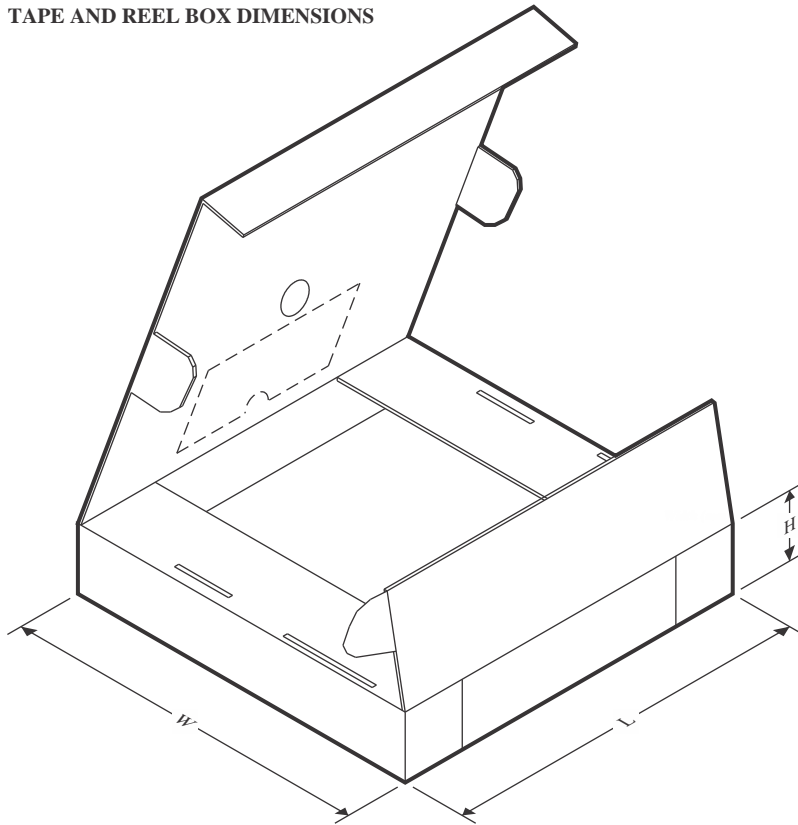
TAPE AND REEL BOX DIMENSIONS

*All dimensions are nominal

Device	Package Type	Package Drawing	Pins	SPQ	Length (mm)	Width (mm)	Height (mm)
TMUX7236PWR	TSSOP	PW	16	2000	353.0	353.0	32.0
TMUX7236RUMR	WQFN	RUM	16	3000	367.0	367.0	35.0

GENERIC PACKAGE VIEW

RUM 16

WQFN - 0.8 mm max height

4 x 4, 0.65 mm pitch

PLASTIC QUAD FLATPACK - NO LEAD

This image is a representation of the package family, actual package may vary.
Refer to the product data sheet for package details.

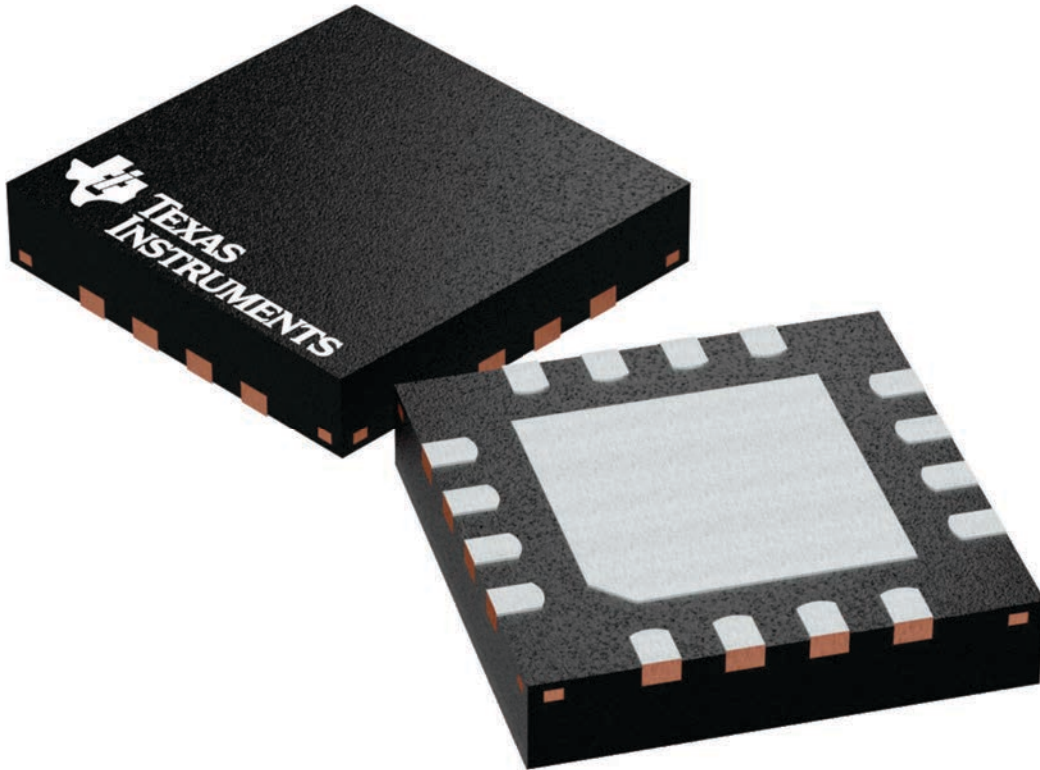

4224843/A

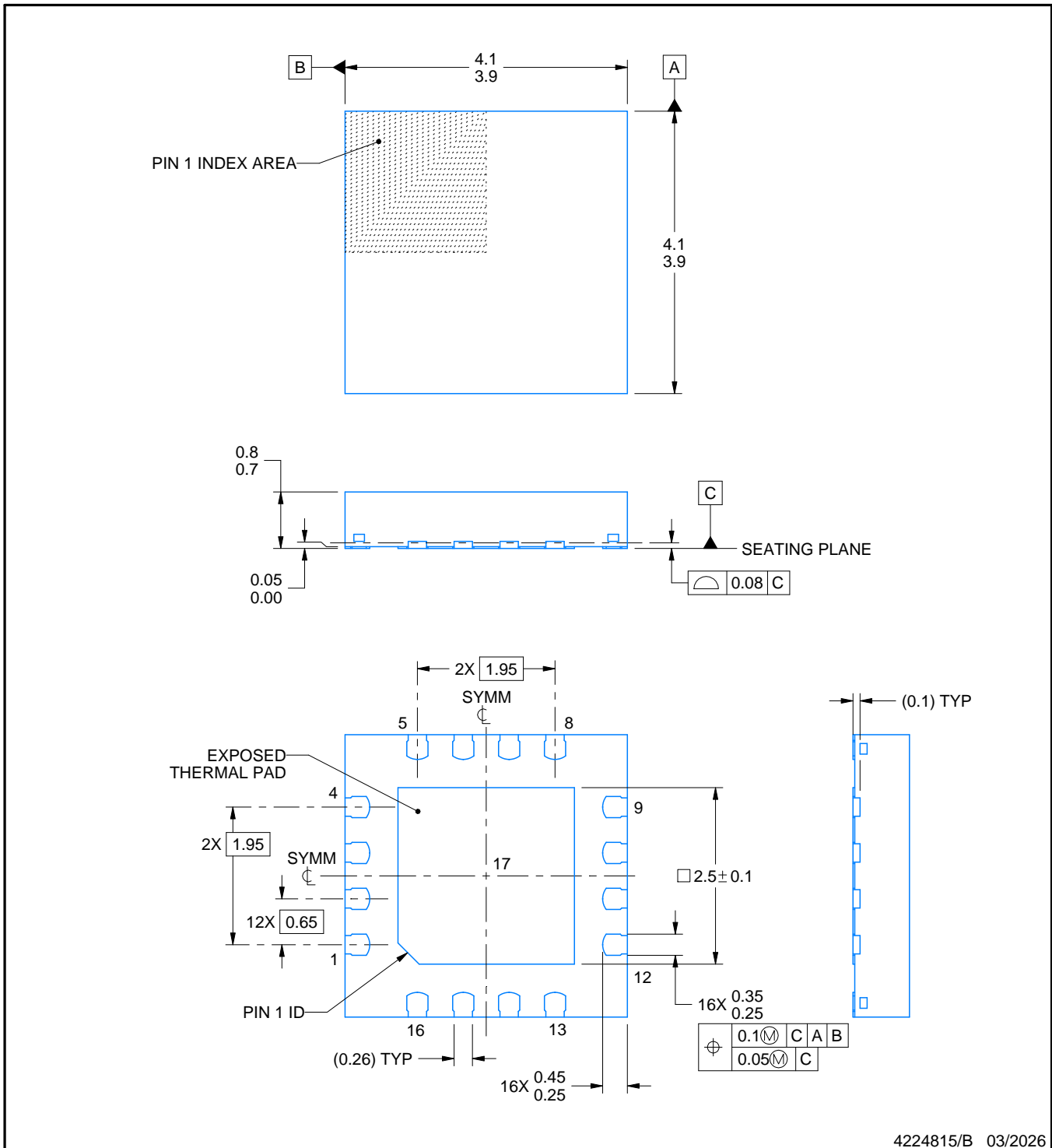
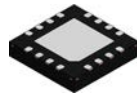

4224815/B 03/2026

NOTES:

1. All linear dimensions are in millimeters. Any dimensions in parenthesis are for reference only. Dimensioning and tolerancing per ASME Y14.5M.
2. This drawing is subject to change without notice.
3. The package thermal pad must be soldered to the printed circuit board for thermal and mechanical performance.

EXAMPLE STENCIL DESIGN

RUM0016E

WQFN - 0.8 mm max height

PLASTIC QUAD FLATPACK - NO LEAD

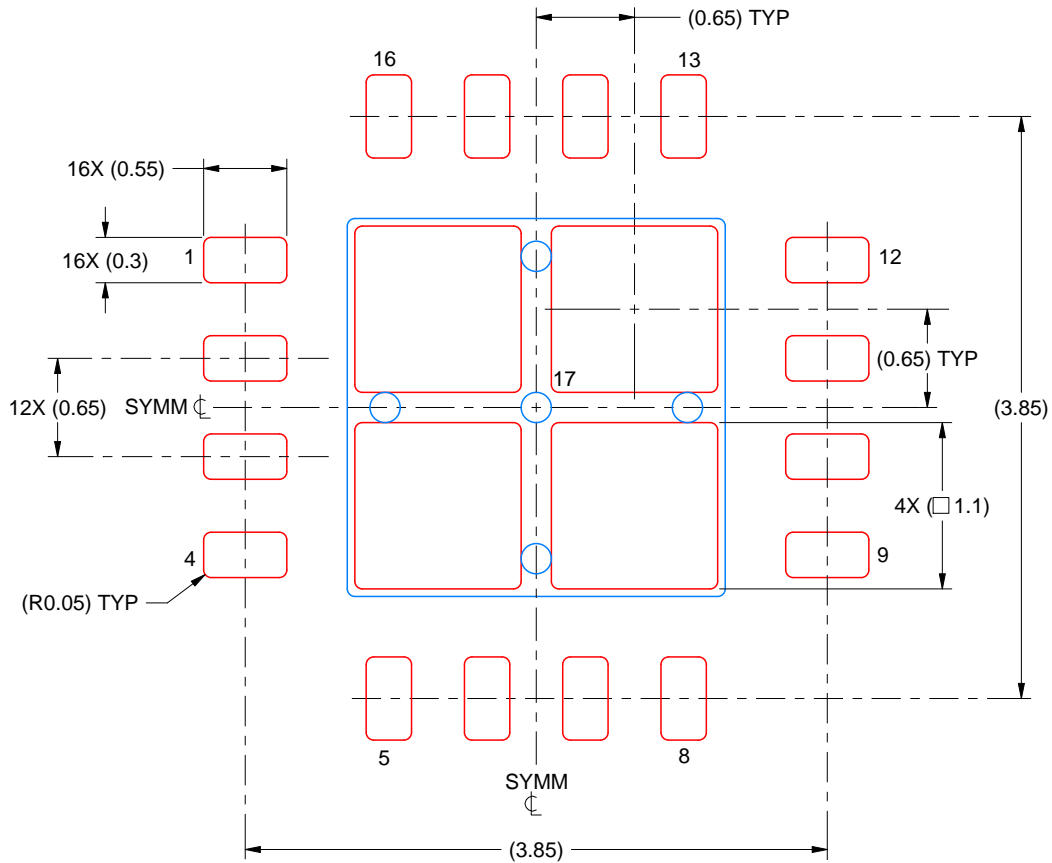

SOLDER PASTE EXAMPLE
BASED ON 0.125 MM THICK STENCIL
SCALE: 20X

EXPOSED PAD 17
77% PRINTED SOLDER COVERAGE BY AREA UNDER PACKAGE

4224815/B 03/2026

NOTES: (continued)

6. Laser cutting apertures with trapezoidal walls and rounded corners may offer better paste release. IPC-7525 may have alternate design recommendations.

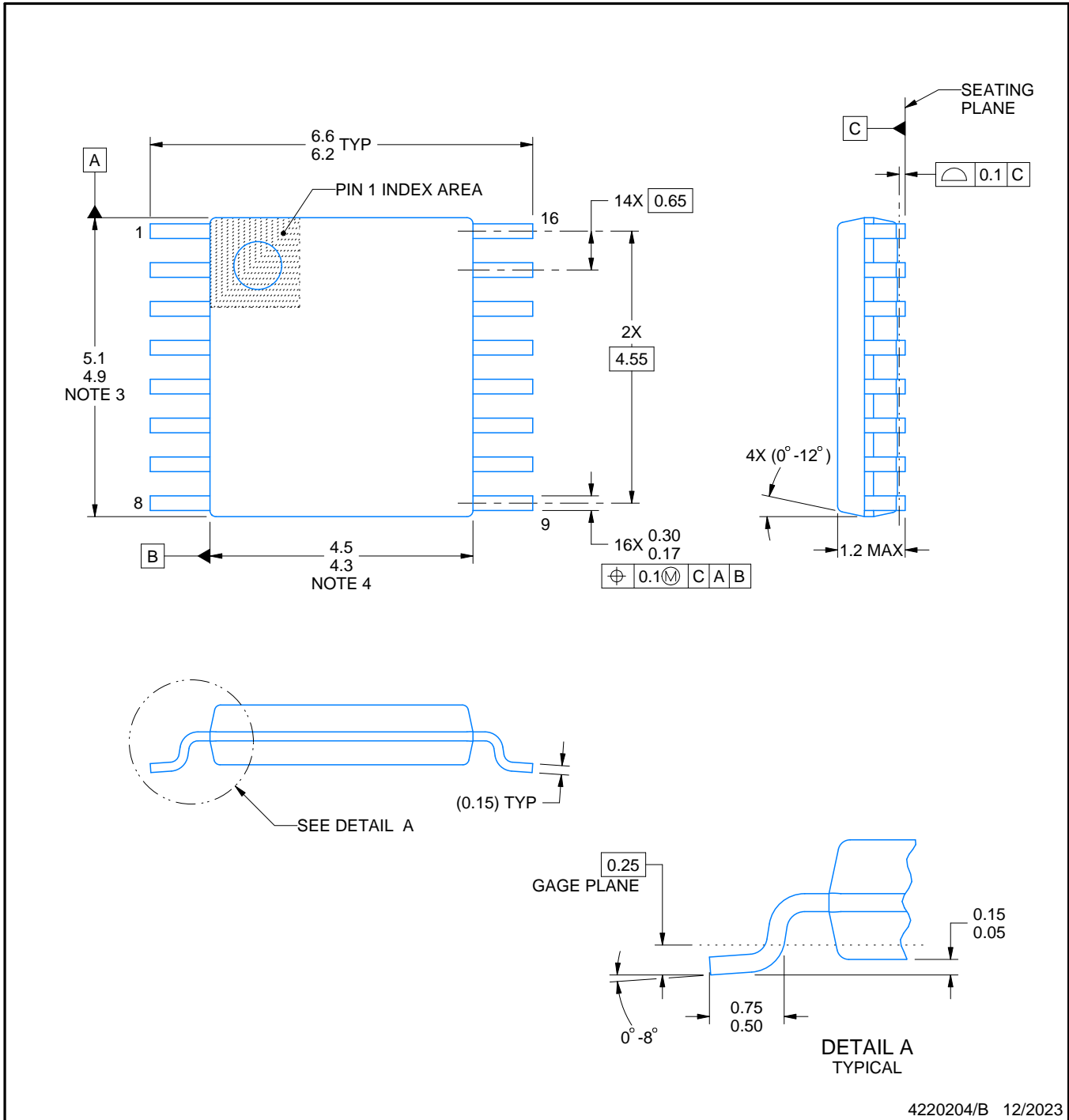
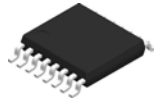

4220204/B 12/2023

NOTES:

1. All linear dimensions are in millimeters. Any dimensions in parenthesis are for reference only. Dimensioning and tolerancing per ASME Y14.5M.
2. This drawing is subject to change without notice.
3. This dimension does not include mold flash, protrusions, or gate burrs. Mold flash, protrusions, or gate burrs shall not exceed 0.15 mm per side.
4. This dimension does not include interlead flash. Interlead flash shall not exceed 0.25 mm per side.
5. Reference JEDEC registration MO-153.

EXAMPLE BOARD LAYOUT

PW0016A

TSSOP - 1.2 mm max height

SMALL OUTLINE PACKAGE

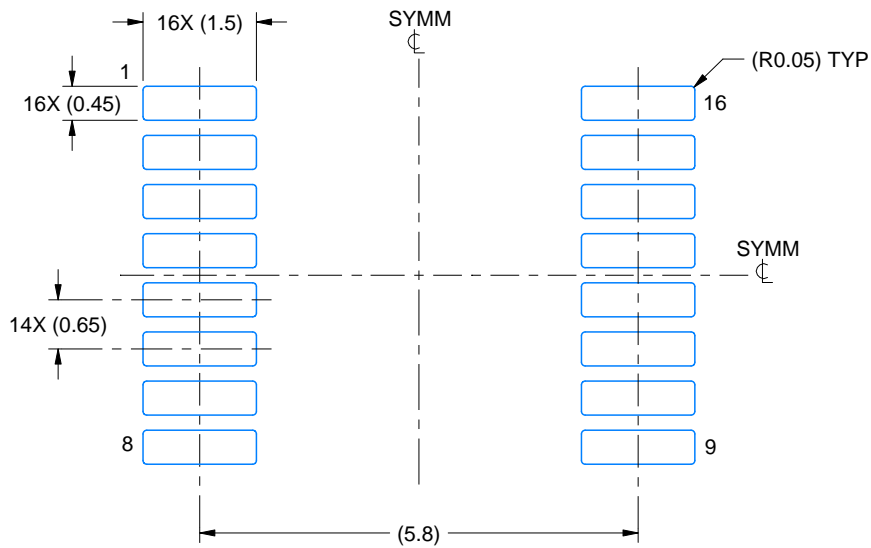

LAND PATTERN EXAMPLE
EXPOSED METAL SHOWN
SCALE: 10X

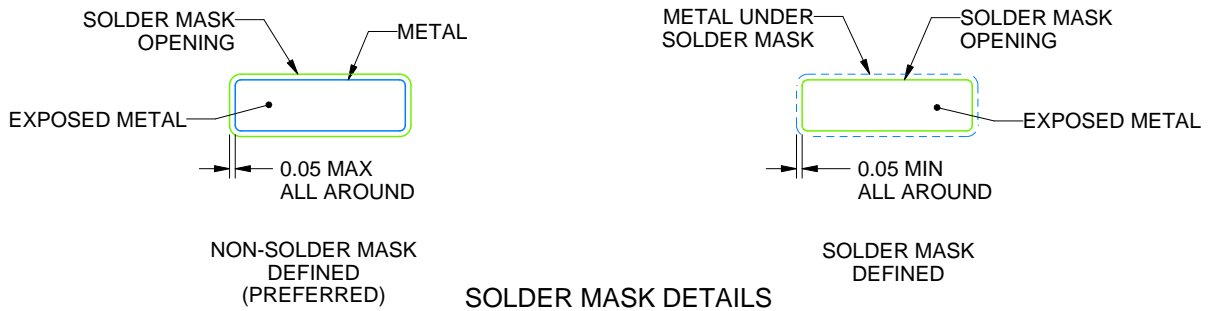

SOLDER MASK DETAILS

4220204/B 12/2023

NOTES: (continued)

6. Publication IPC-7351 may have alternate designs.
7. Solder mask tolerances between and around signal pads can vary based on board fabrication site.

EXAMPLE STENCIL DESIGN

PW0016A

TSSOP - 1.2 mm max height

SMALL OUTLINE PACKAGE

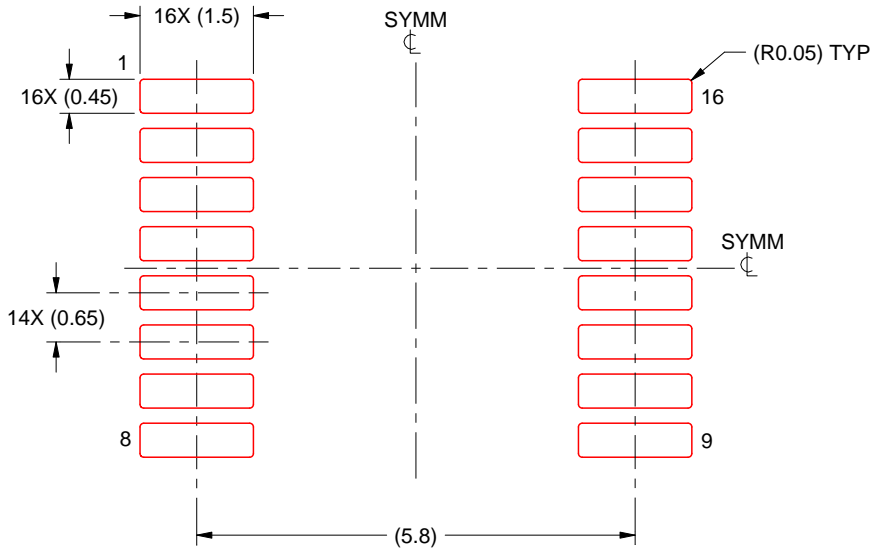

SOLDER PASTE EXAMPLE
BASED ON 0.125 mm THICK STENCIL
SCALE: 10X

4220204/B 12/2023

NOTES: (continued)

8. Laser cutting apertures with trapezoidal walls and rounded corners may offer better paste release. IPC-7525 may have alternate design recommendations.
9. Board assembly site may have different recommendations for stencil design.

重要なお知らせと免責事項

TI は、技術データと信頼性データ (データシートを含みます)、設計リソース (リファレンス デザインを含みます)、アプリケーションや設計に関する各種アドバイス、Web ツール、安全性情報、その他のリソースを、欠陥が存在する可能性のある「現状のまま」提供しており、商品性および特定目的に対する適合性の黙示保証、第三者の知的財産権の非侵害保証を含むいかなる保証も、明示的または黙示的にかかわらず拒否します。

これらのリソースは、TI 製品を使用する設計の経験を積んだ開発者への提供を意図したものです。(1) お客様のアプリケーションに適した TI 製品の選定、(2) お客様のアプリケーションの設計、検証、試験、(3) お客様のアプリケーションに該当する各種規格や、その他のあらゆる安全性、セキュリティ、規制、または他の要件への確実な適合に関する責任を、お客様のみが単独で負うものとし、

上記の各種リソースは、予告なく変更される可能性があります。これらのリソースは、リソースで説明されている TI 製品を使用するアプリケーションの開発の目的でのみ、TI はその使用をお客様に許諾します。これらのリソースに関して、他の目的で複製することや掲載することは禁止されています。TI や第三者の知的財産権のライセンスが付与されている訳ではありません。お客様は、これらのリソースを自身で使用した結果発生するあらゆる申し立て、損害、費用、損失、責任について、TI およびその代理人を完全に補償するものとし、TI は一切の責任を拒否します。

TI の製品は、[TI の販売条件](#)、[TI の総合的な品質ガイドライン](#)、[ti.com](#) または TI 製品などに関連して提供される他の適用条件に従い提供されます。TI がこれらのリソースを提供することは、適用される TI の保証または他の保証の放棄の拡大や変更を意味するものではありません。TI がカスタム、またはカスタマー仕様として明示的に指定していない限り、TI の製品は標準的なカタログに掲載される汎用機器です。

お客様がいかなる追加条項または代替条項を提案する場合も、TI はそれらに異議を唱え、拒否します。

Copyright © 2026, Texas Instruments Incorporated

最終更新日 : 2025 年 10 月