

TPS54622-EP 17-V Input, 6-A Output Synchronous Step Down Switcher

1 Features

- Integrated 26-mΩ and 19-mΩ MOSFETs
- Split power rail: 1.6 V to 17 V on PVIN
- 200-kHz to 1.6-MHz switching frequency
- Synchronizes to external clock
- 0.6V ±1% voltage reference overtemperature
- Hiccup current limit
- Monotonic start-up into prebiased outputs
- Adjustable slow start and power sequencing
- Power good output monitor for undervoltage and overvoltage
- Adjustable input undervoltage lockout
- Pin compatible with **TPS54620**
- For SWIFT™ documentation, visit <http://www.ti.com/swift>
- Create a custom design using the TPS54622-EP with the **WEBENCH® Power Designer**

2 Applications

- High-Density Distributed Power Systems
- High-Performance Point-of-Load Regulation
- Broadband, Networking, and Optical Communications Infrastructure
- **Supports Defense, Aerospace, and Medical Applications**
 - Controlled Baseline
 - One Assembly and Test Site
 - One Fabrication Site
 - Rated from –55°C to 125°C
 - Extended Product Life Cycle
 - Extended Product-Change Notification
 - Product Traceability

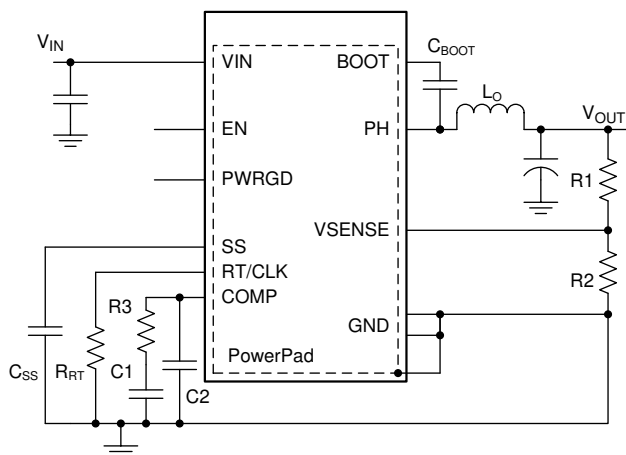

Simplified Schematic

3 Description

The TPS54622-EP device in thermally enhanced 3.5-mm × 3.5-mm VQFN package is a full-featured 17-V, 6-A synchronous step-down converter optimized for small designs through high efficiency and integrating the high-side and low-side MOSFETs. Further space savings are achieved through current mode control, which reduces component count, and by selecting a high switching frequency, reducing the footprint of the inductor.

The output voltage start-up ramp is controlled by the SS/TR pin, which allows operation as either a stand-alone power supply or in tracking situations. Power sequencing is also possible by correctly configuring the enable and the open-drain power good pins.

Cycle-by-cycle current limiting on the high-side FET protects the device in overload situations and is enhanced by a low-side sourcing current limit that prevents current runaway. There is also a low-side sinking current limit that turns off the low-side MOSFET to prevent excessive reverse current. Hiccup protection is triggered if the overcurrent condition has persisted for longer than the preset time. Thermal hiccup protection disables the device when the die temperature exceeds the thermal shutdown temperature and enables the part again after the built-in thermal shutdown hiccup time.

Device Information

PART NUMBER	PACKAGE ⁽¹⁾	BODY SIZE (NOM)
TPS54622-EP	VQFN (14)	3.50 mm × 3.50 mm

- (1) For all available packages, see the orderable addendum at the end of the data sheet.

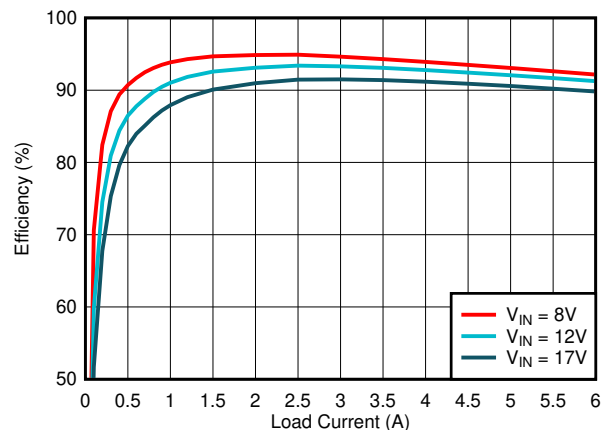

Efficiency vs Load Current



Table of Contents

1 Features	1	8.1 Application Information.....	23
2 Applications	1	8.2 Typical Application.....	23
3 Description	1	9 Power Supply Recommendations	32
4 Revision History	2	10 Layout	32
5 Pin Configurations and Functions	3	10.1 Layout Guidelines.....	32
6 Specifications	4	10.2 Layout Examples.....	33
6.1 Absolute Maximum Ratings	4	10.3 Estimated Circuit Area.....	34
6.2 ESD Ratings	4	11 Device and Documentation Support	35
6.3 Recommended Operating Conditions	4	11.1 Device Support.....	35
6.4 Thermal Information	5	11.2 Documentation Support.....	35
6.5 Electrical Characteristics	5	11.3 Receiving Notification of Documentation Updates..	35
6.6 Typical Characteristics.....	7	11.4 Support Resources.....	35
7 Detailed Description	10	11.5 Trademarks.....	35
7.1 Overview.....	10	11.6 Electrostatic Discharge Caution.....	35
7.2 Functional Block Diagram.....	11	11.7 Glossary.....	35
7.3 Feature Description.....	11	12 Mechanical, Packaging, and Orderable	
7.4 Device Functional Modes.....	19	Information	36
8 Application and Implementation	23		

4 Revision History

NOTE: Page numbers for previous revisions may differ from page numbers in the current version.

DATE	REVISION	NOTES
December 2020	*	Initial release.

5 Pin Configurations and Functions

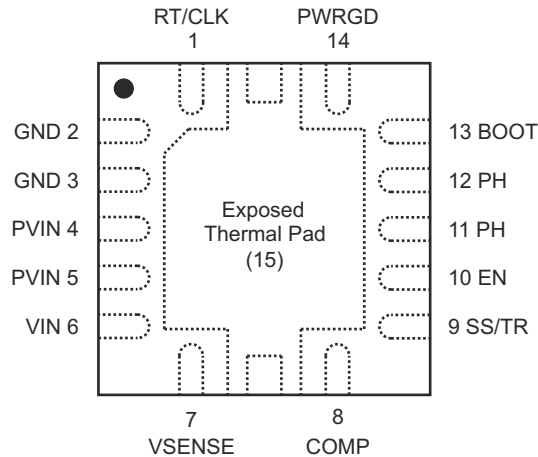

Figure 5-1. RHL Package 14-Pin VQFN With Exposed Thermal Pad Top View

Table 5-1. Pin Functions

PIN		I/O ⁽¹⁾	DESCRIPTION
NAME	NO.		
BOOT	13	I	A bootstrap cap is required between BOOT and PH. The voltage on this cap carries the gate drive voltage for the high-side MOSFET.
COMP	8	O	Error amplifier output, and input to the output switch current comparator. Connect frequency compensation to this pin.
EN	10	I	Enable pin. Float to enable. Adjust the input undervoltage lockout with two resistors.
GND	2, 3	G	Return for control circuitry and low-side power MOSFET.
PH	11, 12	O	The switch node.
PVIN	4, 5	P	Power input. Supplies the power switches of the power converter.
PWRGD	14	G	Power Good fault pin. Asserts low if output voltage is low due to thermal shutdown, dropout, over-voltage, EN shutdown or during slow start.
RT/CLK	1	I	Automatically selects between RT mode and CLK mode. An external timing resistor adjusts the switching frequency of the device; In CLK mode, the device synchronizes to an external clock.
SS/TR	9	O	Slow start and tracking. An external capacitor connected to this pin sets the internal voltage reference rise time. The voltage on this pin overrides the internal reference. It can be used for tracking and sequencing.
VIN	6	P	Supplies the control circuitry of the power converter.
VSENSE	7	I	Inverting input of the gm error amplifier.
Exposed Thermal PAD	15	G	Thermal pad of the package and signal ground and it must be soldered down for proper operation.

(1) I = input, O = output, G = GND, P = Power

6 Specifications

6.1 Absolute Maximum Ratings

Over operating junction temperature range (unless otherwise noted)⁽¹⁾

		MIN	MAX	UNIT
Input Voltage	VIN	-0.3	20	V
	PVIN	-0.3	20	
	EN	-0.3	6	
	BOOT	-0.3	27	
	VSENSE	-0.3	3	
	COMP	-0.3	3	
	PWRGD	-0.3	6	
	SS/TR	-0.3	3	
	RT/CLK	-0.3	6	
Output Voltage	BOOT-PH	0	7.5	V
	PH	-1	20	
	PH 10-ns Transient	-3	20	
	PH 5-ns Transient	-4	20	
Vdiff (GND to exposed thermal pad)		-0.2	0.2	V
Source Current	RT/CLK		±100	µA
	PH		Current Limit	A
Sink Current	PH		Current Limit	A
	PVIN		Current Limit	A
	COMP		±200	µA
	PWRGD	-0.1	5	mA
Operating Junction Temperature		-55	150	°C
Storage Temperature, T _{stg}		-65	150	°C

- (1) Stresses beyond those listed under *Absolute Maximum Ratings* may cause permanent damage to the device. These are stress ratings only, and functional operation of the device at these or any other conditions beyond those indicated under *Recommended Operating Conditions* is not implied. Exposure to absolute-maximum-rated conditions for extended periods may affect device reliability.

6.2 ESD Ratings

			VALUE	UNIT
V _(ESD)	Electrostatic discharge	Human body model (HBM), per ANSI/ESDA/JEDEC JS-001 ⁽¹⁾	2000	V
		Charged device model (CDM), per JEDEC specification JESD22-C101 ⁽²⁾	500	

- (1) JEDEC document JEP155 states that 500-V HBM allows safe manufacturing with a standard ESD control process.
 (2) JEDEC document JEP157 states that 250-V CDM allows safe manufacturing with a standard ESD control process.

6.3 Recommended Operating Conditions

Over operating free-air temperature range (unless otherwise noted)

		MIN	NOM	MAX	UNIT
Input voltage	VIN	4.5		17	V
Power stage input voltage	PVIN	1.6		17	V
Output current		0		6	A
Operating junction temperature, T _J		-55		150	°C

6.4 Thermal Information

THERMAL METRIC ^{(1) (2)}		TPS54622-EP	UNIT
		RHL (VQFN)	
		14 PINS	
R _{θJA}	Junction-to-ambient thermal resistance	47.2	°C/W
R _{θJA}	Junction-to-ambient thermal resistance ⁽³⁾	32	°C/W
R _{θJCTop}	Junction-to-case (top) thermal resistance	64.8	°C/W
R _{θJB}	Junction-to-board thermal resistance	14.4	°C/W
Ψ _{JT}	Junction-to-top characterization parameter	0.5	°C/W
Ψ _{JB}	Junction-to-board characterization parameter	14.7	°C/W
R _{θJCbott}	Junction-to-case (bottom) thermal resistance	3.2	°C/W

- (1) For more information about traditional and new thermal metrics, see the *Semiconductor and IC Package Thermal Metrics* application report, [SPRA953](#).
- (2) Power rating at a specific ambient temperature T_A should be determined with a junction temperature of 150°C. This is the point where distortion starts to substantially increase. Thermal management of the PCB should strive to keep the junction temperature at or below 150°C for best performance and long-term reliability. See the power dissipation estimate in the application section of this datasheet for more information.
- (3) Test Board Conditions:
 - 2.5 inches × 2.5 inches, 4 layers, thickness: 0.062 inch
 - 2 oz. copper traces located on the top of the PCB
 - 2 oz. copper ground planes on the 2 internal layers of and the bottom layer
 - 4 0.010 inch thermal vias located under the device package

6.5 Electrical Characteristics

T_J = –55°C to 150°C, VIN = 4.5 V to 17 V, PVIN = 1.6 V to 17 V (unless otherwise noted)

PARAMETER	TEST CONDITIONS	MIN	TYP	MAX	UNIT
SUPPLY VOLTAGE (VIN AND PVIN PINS)					
VIN internal UVLO threshold	VIN rising		4	4.5	V
VIN internal UVLO hysteresis			150		mV
VIN shutdown supply Current	EN = 0 V		2	5	μA
VIN operating – non switching supply current	VSENSE = 810 mV		600	800	μA
ENABLE AND UVLO (EN PIN)					
Enable threshold	Rising		1.22	1.26	V
Enable threshold	Falling	1.1	1.18		
Input current	EN = 1.1 V		1.08		μA
Hysteresis current	EN = 1.3 V		3.2		μA
VOLTAGE REFERENCE					
Voltage reference	0 A ≤ I _{OUT} ≤ 6 A	0.594	0.6	0.606	V
MOSFET					
High-side switch resistance	BOOT-PH = 3 V		32	60	mΩ
High-side switch resistance ⁽¹⁾	BOOT-PH = 6 V		26	40	mΩ
Low-side Switch Resistance ⁽¹⁾	VIN = 12 V		19	30	mΩ
ERROR AMPLIFIER					
Error amplifier Transconductance (gm)	–2 μA < I _{COMP} < 2 μA, V _(COMP) = 1 V		1300		μMhos
Error amplifier dc gain	VSENSE = 0.6 V	1000	3100		V/V
Error amplifier source/sink	V _(COMP) = 1 V, 100-mV input overdrive		±125		μA
Start switching threshold			0.25		V
COMP to Iswitch gm			16		A/V

6.5 Electrical Characteristics (continued)

$T_J = -55^{\circ}\text{C}$ to 150°C , $V_{IN} = 4.5\text{ V}$ to 17 V , $PV_{IN} = 1.6\text{ V}$ to 17 V (unless otherwise noted)

PARAMETER	TEST CONDITIONS	MIN	TYP	MAX	UNIT
CURRENT LIMIT					
High-side switch current limit threshold		8	11	14	A
Low-side switch sourcing current limit		6.5	10	15	A
Low-side switch sinking current limit		2	3	4	A
Hiccup wait time			512		Cycles
Hiccup time before re-start			16384		Cycles
THERMAL SHUTDOWN					
Thermal shutdown ⁽²⁾		160	175		$^{\circ}\text{C}$
Thermal shutdown hysteresis ⁽²⁾			10		$^{\circ}\text{C}$
Thermal shutdown hiccup time ⁽²⁾			16384		Cycles
TIMING RESISTOR AND EXTERNAL CLOCK (RT/CLK PIN)					
Minimum switching frequency	$R_{rt} = 240\text{ k}\Omega$ (1%)	160	200	240	kHz
Switching frequency	$R_{rt} = 100\text{ k}\Omega$ (1%)	400	480	560	kHz
Maximum switching frequency	$R_{rt} = 29\text{ k}\Omega$ (1%)	1500	1600	1900	kHz
Minimum pulse width			20		ns
RT/CLK high threshold				2	V
RT/CLK low threshold		0.7			V
RT/CLK falling edge to PH rising edge delay	Measure at 500 kHz with RT resistor in series		66		ns
Switching frequency range (RT mode set point and CLK mode)		200		1600	kHz
PH (PH PIN)					
Minimum on-time	Measured at 90% to 90% of V_{IN} , 25°C , $I_{PH} = 2\text{ A}$		100	145	ns
BOOT (BOOT PIN)					
BOOT-PH UVLO			2.3	3	V
SLOW START AND TRACKING (SS/TR PIN)					
SS charge current			2.14		μA
SS/TR to VSENSE matching	$V_{(SS/TR)} = 0.4\text{ V}$		16	60	mV
POWER GOOD (PWRGD PIN)					
VSENSE threshold	VSENSE falling (Fault)		92		% Vref
	VSENSE rising (Good)		94		% Vref
	VSENSE rising (Fault)		111		% Vref
	VSENSE falling (Good)		109		% Vref
Output high leakage	$V_{SENSE} = V_{ref}$, $V_{(PWRGD)} = 5.5\text{ V}$		30	100	nA
Output low sink current	$V_{(PWRGD)} = 0.3\text{ V}$	2			mA
Minimum V_{IN} for valid output	$V_{(PWRGD)} < 0.5\text{ V}$ at $100\text{ }\mu\text{A}$		0.6	1	V
Minimum SS/TR voltage for PWRGD				1.4	V

(1) Measured at pins.

(2) Specified by design. Not production tested.

6.6 Typical Characteristics

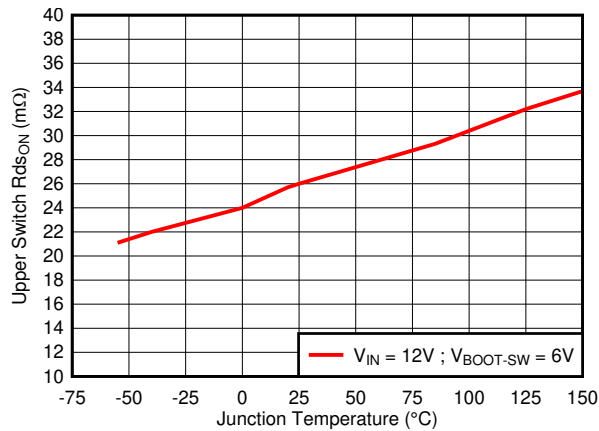

Figure 6-1. High-Side $R_{DS(on)}$ vs Temperature

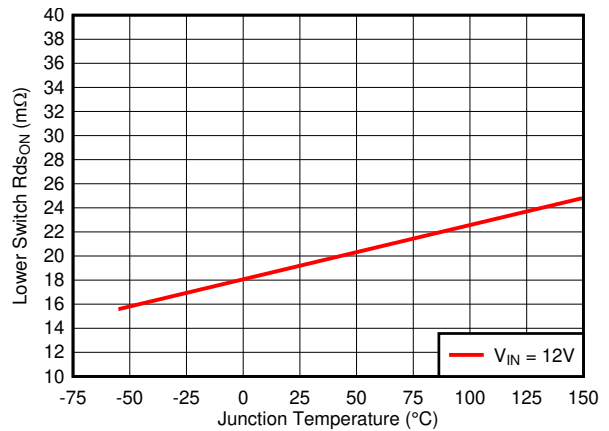

Figure 6-2. Low-Side $R_{DS(on)}$ vs Temperature

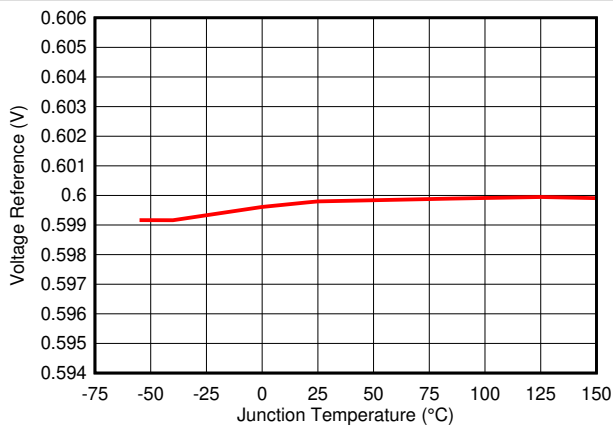

Figure 6-3. Voltage Reference vs Temperature

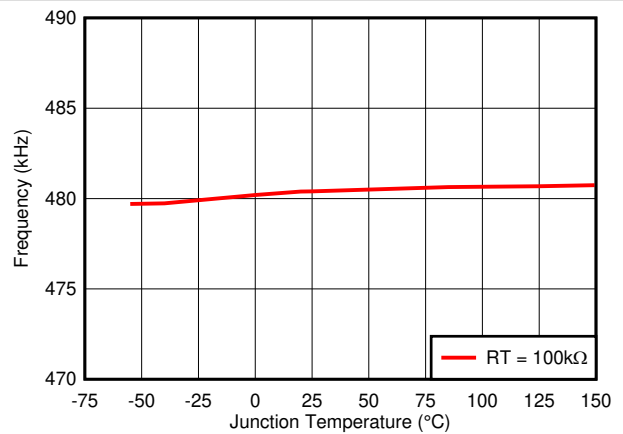

Figure 6-4. Oscillator Frequency vs Temperature

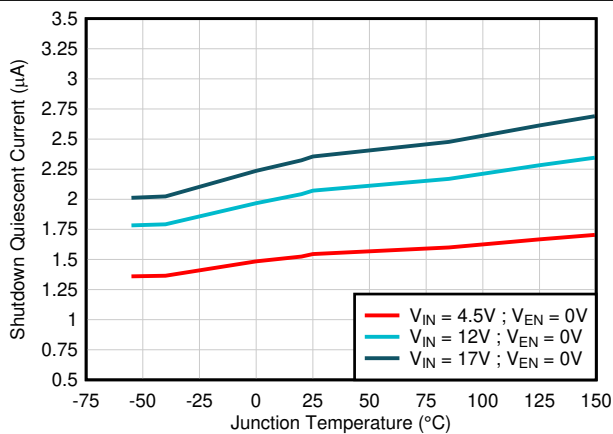

Figure 6-5. Shutdown Quiescent Current vs Temperature

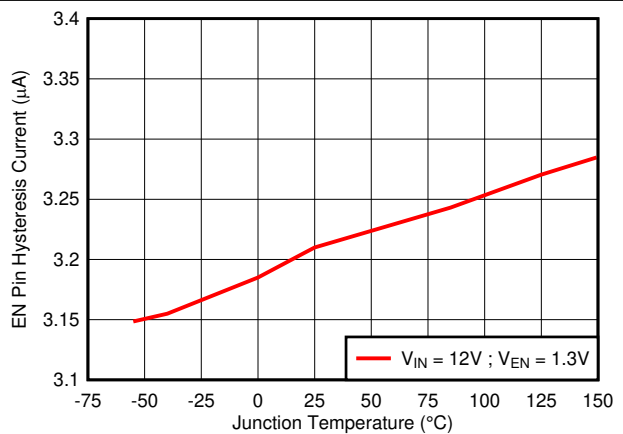

Figure 6-6. EN Pin Hysteresis Current vs Temperature

6.6 Typical Characteristics (continued)

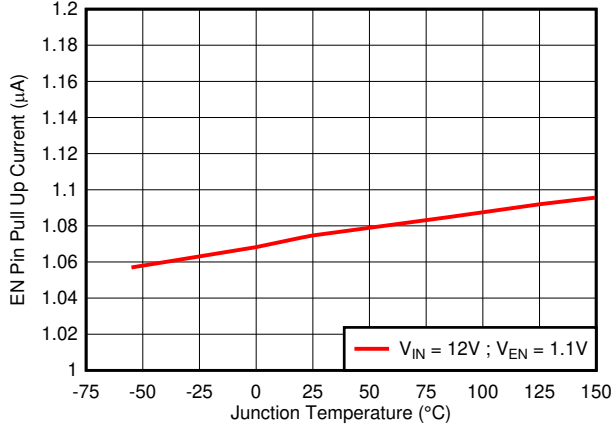

Figure 6-7. EN Pin Pullup Current vs Temperature

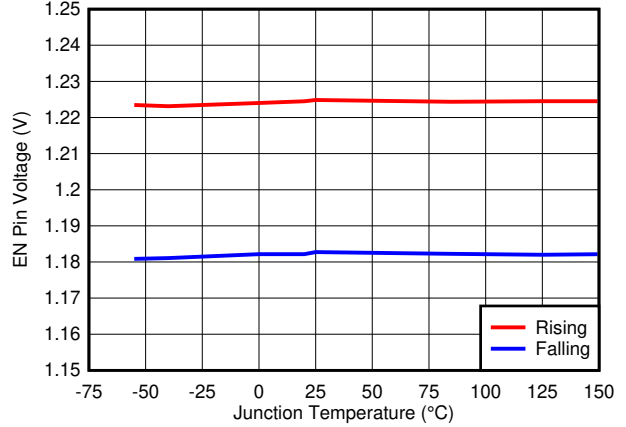

Figure 6-8. EN Pin UVLO Threshold vs Temperature

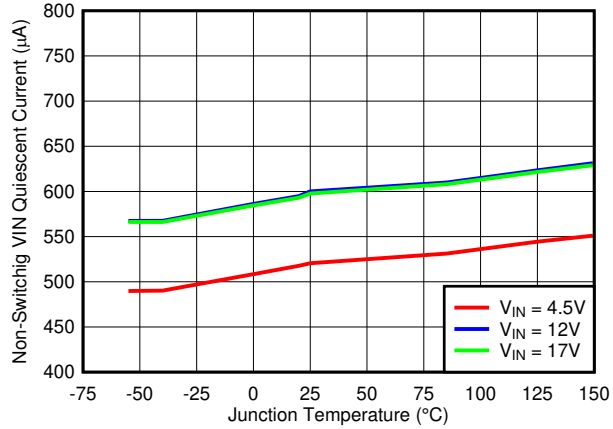

Figure 6-9. Non-Switching Operating Quiescent Current vs Temperature

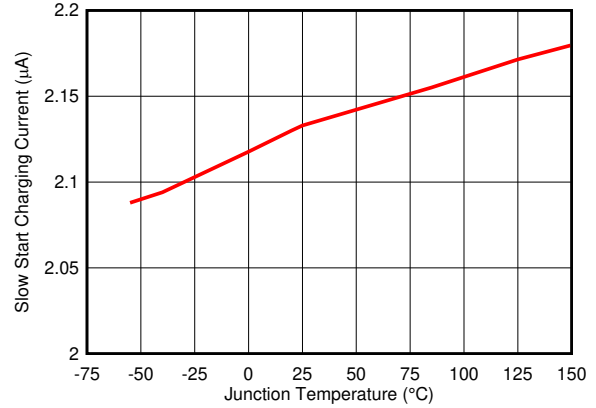

Figure 6-10. Slow Start Charge Current vs Temperature

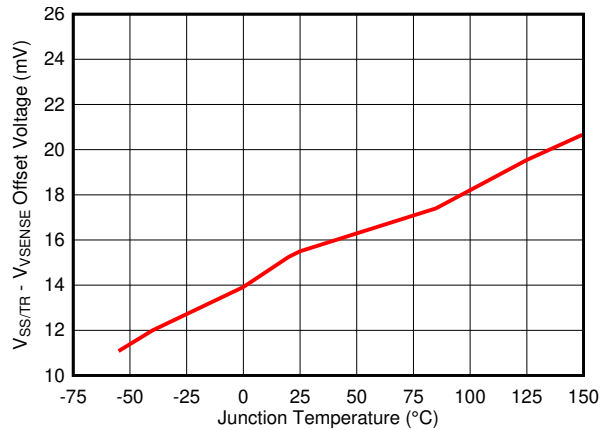

Figure 6-11. (SS/TR - VSENSE) Offset vs Temperature

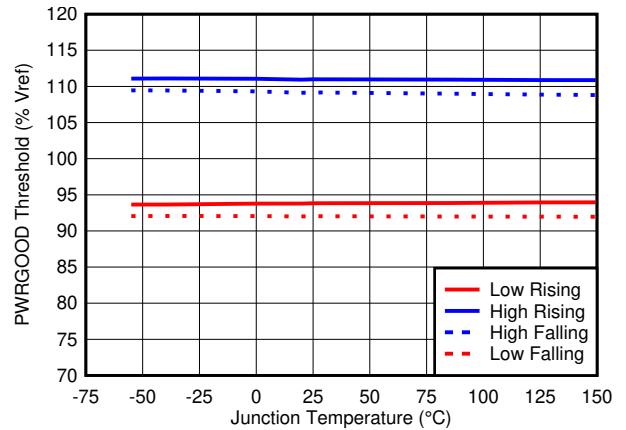

Figure 6-12. PWRGD Threshold vs Temperature

6.6 Typical Characteristics (continued)

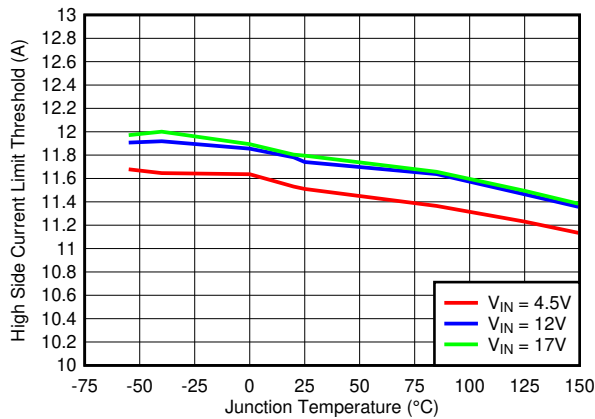

Figure 6-13. High-Side Current Limit Threshold vs Temperature

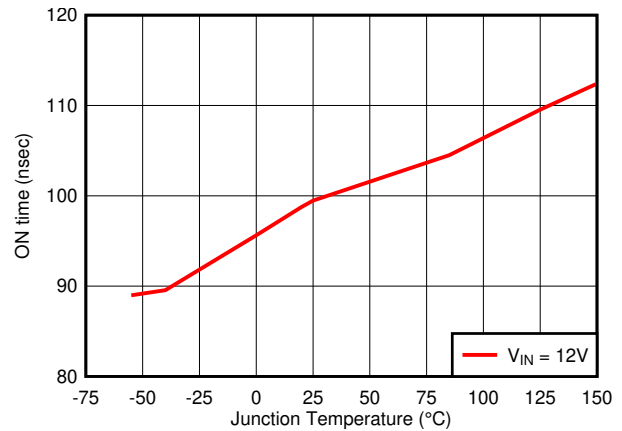

Figure 6-14. Minimum Controllable On-Time vs Temperature

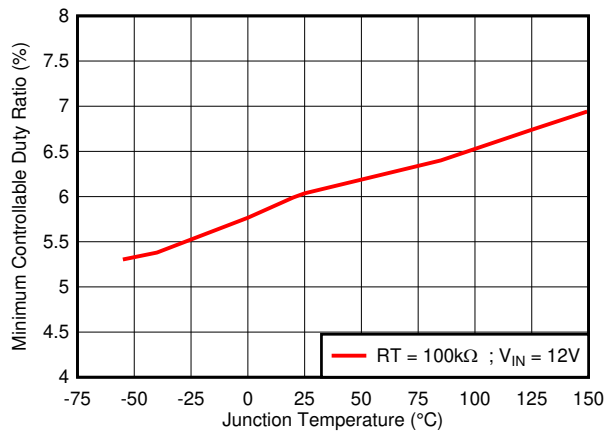

Figure 6-15. Minimum Controllable Duty Ratio vs Temperature

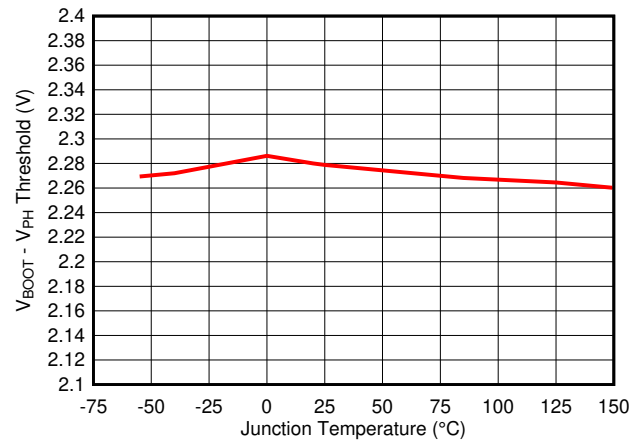

Figure 6-16. BOOT-PH UVLO Threshold vs Temperature

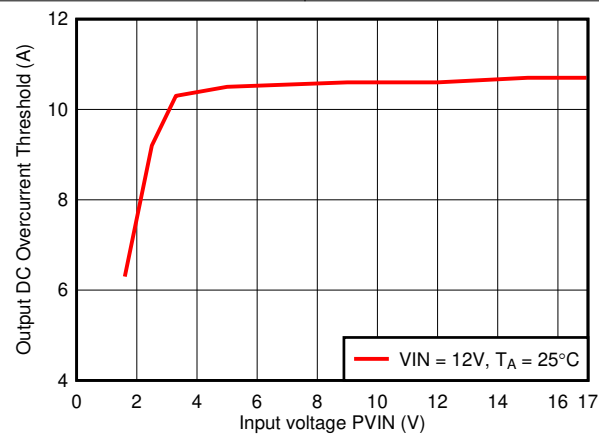

Figure 6-17. Overcurrent Threshold vs Input Voltage

7 Detailed Description

7.1 Overview

The TPS54622-EP device is a 17-V, 6-A, synchronous step-down (buck) converter with two integrated N-channel MOSFETs. To improve performance during line and load transients the device implements a constant frequency, peak current mode control which also simplifies external frequency compensation. The wide switching frequency of 200 kHz to 1600 kHz allows for efficiency and size optimization when selecting the output filter components. The switching frequency is adjusted using a resistor to ground on the RT/CLK pin. The device also has an internal phase lock loop (PLL) controlled by the RT/CLK pin that can be used to synchronize the switching cycle to the falling edge of an external system clock.

The device has been designed for safe monotonic start-up into prebiased loads. The default start-up is when VIN is typically 4 V. The EN pin has an internal pullup current source that can be used to adjust the input voltage undervoltage lockout (UVLO) with two external resistors. In addition, the EN pin can be floating for the device to operate with the internal pullup current. The total operating current for the device is approximately 600 μ A when not switching and under no load. When the device is disabled, the supply current is typically less than 2 μ A.

The integrated MOSFETs allow for high-efficiency power supply designs with continuous output currents up to 6 amperes. The MOSFETs have been sized to optimize efficiency for lower duty cycle applications.

The device reduces the external component count by integrating the boot recharge circuit. The bias voltage for the integrated high-side MOSFET is supplied by a capacitor between the BOOT and PH pins. The boot capacitor voltage is monitored by a BOOT to PH UVLO (BOOT-PH UVLO) circuit allowing PH pin to be pulled low to recharge the boot capacitor. The device can operate at 100% duty cycle as long as the boot capacitor voltage is higher than the preset BOOT-PH UVLO threshold which is typically 2.1 V. The output voltage can be stepped down to as low as the 0.6-V voltage reference (Vref).

The device has a power good comparator (PWRGD) with hysteresis which monitors the output voltage through the VSENSE pin. The PWRGD pin is an open-drain MOSFET which is pulled low when the VSENSE pin voltage is less than 92% or greater than 106% of the reference voltage Vref and asserts high when the VSENSE pin voltage is 94% to 104% of the Vref.

The SS/TR (slow start/tracking) pin is used to minimize inrush currents or provide power supply sequencing during power up. A small value capacitor or resistor divider should be coupled to the pin for slow start or critical power supply sequencing requirements.

The device is protected from output overvoltage, overload, and thermal fault conditions. The device minimizes excessive output overvoltage transients by taking advantage of the overvoltage circuit power good comparator. When the overvoltage comparator is activated, the high-side MOSFET is turned off and prevented from turning on until the VSENSE pin voltage is lower than 104% of the Vref. The device implements both high-side MOSFET overload protection and bidirectional low-side MOSFET overload protections which help control the inductor current and avoid current runaway. The device also shuts down if the junction temperature is higher than thermal shutdown trip point. The device is restarted under control of the slow start circuit automatically after the built-in thermal shutdown hiccup time.

7.2 Functional Block Diagram

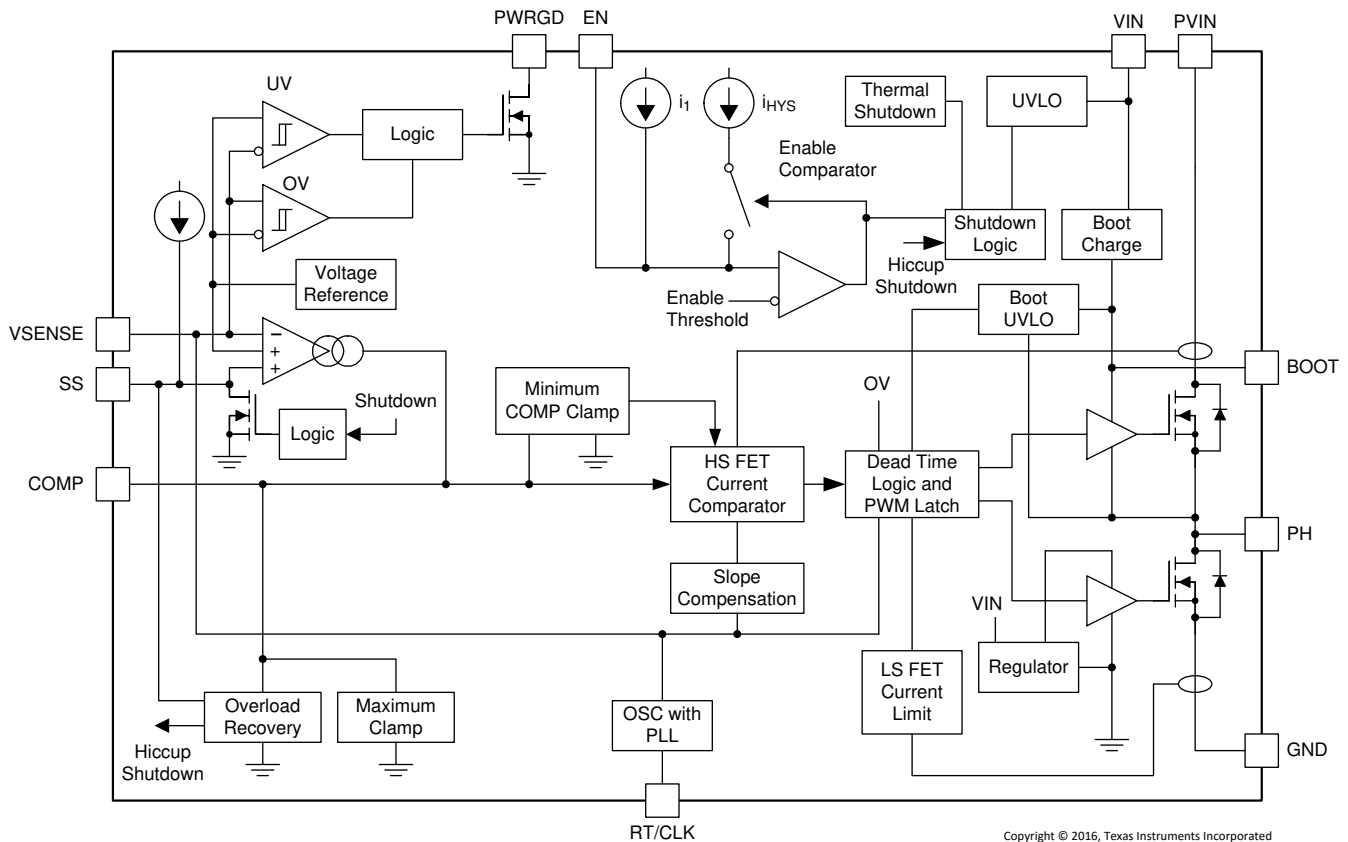

Copyright © 2016, Texas Instruments Incorporated

7.3 Feature Description

7.3.1 Fixed-Frequency PWM Control

The device uses an adjustable fixed-frequency, peak current mode control. The output voltage is compared through external resistors on the VSENSE pin to an internal voltage reference by an error amplifier which drives the COMP pin. An internal oscillator initiates the turnon of the high-side power switch. The error amplifier output is converted into a current reference which compares to the high-side power switch current. When the power switch current reaches current reference generated by the COMP voltage level the high-side power switch is turned off and the low-side power switch is turned on.

7.3.2 Continuous Current Mode Operation (CCM)

As a synchronous buck converter, the device normally works in continuous conduction mode (CCM) under all load conditions.

7.3.3 VIN and Power VIN Pins (VIN and PVIN)

The device allows for a variety of applications by using the VIN and PVIN pins together or separately. The VIN pin voltage supplies the internal control circuits of the device. The PVIN pin voltage provides the input voltage to the power converter system.

If tied together, the input voltage for VIN and PVIN can range from 4.5 V to 17 V. If using the VIN separately from PVIN, the VIN pin must be from 4.5 V to 17 V, and the PVIN pin can range from as low as 1.6 V to 17 V. A voltage divider connected to the EN pin can adjust the either input voltage UVLO appropriately. Adjusting the input voltage UVLO on the PVIN pin helps to provide consistent power-up behavior.

7.3.4 Voltage Reference

The voltage reference system produces a precise $\pm 1\%$ voltage reference overtemperature by scaling the output of a temperature stable bandgap circuit.

7.3.5 Adjusting the Output Voltage

The output voltage is set with a resistor-divider from the output (VOUT) to the VSENSE pin. TI recommends using 1% tolerance or better divider resistors. Referring to the application schematic of [Figure 8-1](#), start with a 10 kΩ for R6 and use [Equation 1](#) to calculate R5. To improve efficiency at light loads, consider using larger value resistors. If the values are too high, the regulator is more susceptible to noise and voltage errors from the VSENSE input current and are noticeable.

$$R5 = \frac{V_o - V_{ref}}{V_{ref}} R6 \quad (1)$$

where

- $V_{ref} = 0.6 \text{ V}$

The minimum output voltage and maximum output voltage can be limited by the minimum on-time of the high-side MOSFET and bootstrap voltage (BOOT-PH voltage) respectively. More discussions are located in [Minimum Output Voltage](#) and [Bootstrap Voltage \(BOOT\) and Low Dropout Operation](#).

7.3.6 Safe Start-Up Into Prebiased Outputs

The device has been designed to prevent the low-side MOSFET from discharging a prebiased output. During monotonic prebiased startup, the low-side MOSFET is not allowed to sink current until the SS/TR pin voltage is higher than 1.4 V.

7.3.7 Error Amplifier

The device uses a transconductance error amplifier. The error amplifier compares the VSENSE pin voltage to the lower of the SS/TR pin voltage or the internal 0.6-V voltage reference. The transconductance of the error amplifier is 1300 μA/V during normal operation. The frequency compensation network is connected between the COMP pin and ground.

7.3.8 Slope Compensation

The device adds a compensating ramp to the switch current signal. This slope compensation prevents sub-harmonic oscillations. The available peak inductor current remains constant over the full duty cycle range.

7.3.9 Enable and Adjusting Undervoltage Lockout

The EN pin provides electrical on/off control of the device. Once the EN pin voltage exceeds the threshold voltage, the device starts operation. If the EN pin voltage is pulled below the threshold voltage, the regulator stops switching and enters low Iq state.

The EN pin has an internal pullup current source, allowing the user to float the EN pin for enabling the device. If an application requires controlling the EN pin, use open-drain or open collector output logic to interface with the pin.

The device implements internal UVLO circuitry on the VIN pin. The device is disabled when the VIN pin voltage falls below the internal VIN UVLO threshold. The internal VIN UVLO threshold has a hysteresis of 150 mV.

If an application requires either a higher UVLO threshold on the VIN pin or a secondary UVLO on the PVIN, in split rail applications, then the EN pin can be configured as shown in [Figure 7-1](#), [Figure 7-2](#), and [Figure 7-3](#). When using the external UVLO function, TI recommends setting the hysteresis to be greater than 500 mV.

The EN pin has a small pullup current I_p which sets the default state of the pin to enable when no external components are connected. The pullup current is also used to control the voltage hysteresis for the UVLO function since it increases by I_p once the EN pin crosses the enable threshold. The UVLO thresholds can be calculated using [Equation 2](#) and [Equation 3](#).

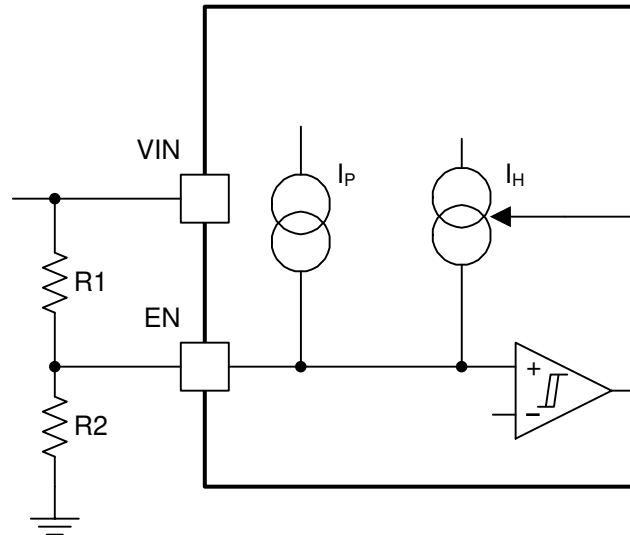

Copyright © 2016, Texas Instruments Incorporated

Figure 7-3. Adjustable VIN and PVIN Undervoltage Lockout

$$R1 = \frac{V_{START} \left(\frac{V_{ENFALLING}}{V_{ENRISING}} \right) - V_{STOP}}{I_p \left(1 - \frac{V_{ENFALLING}}{V_{ENRISING}} \right) + I_h} \quad (2)$$

$$R2 = \frac{R1 \times V_{ENFALLING}}{V_{STOP} - V_{ENFALLING} + R1(I_p + I_h)} \quad (3)$$

where

- $I_h = 3.4 \mu\text{A}$
- $I_p = 1.15 \mu\text{A}$
- $V_{ENRISING} = 1.21 \text{ V}$
- $V_{ENFALLING} = 1.17 \text{ V}$

7.3.10 Adjustable Switching Frequency and Synchronization (RT/CLK)

The RT/CLK pin can be used to set the switching frequency of the device in two modes.

In RT mode, a resistor (RT resistor) is connected between the RT/CLK pin and GND. The switching frequency of the device is adjustable from 200 kHz to 1600 kHz by placing a maximum of 240 kΩ and minimum of 29 kΩ respectively. In CLK mode, an external clock is connected directly to the RT/CLK pin. The device is synchronized to the external clock frequency with PLL.

The CLK mode overrides the RT mode. The device is able to detect the proper mode automatically and switch from the RT mode to CLK mode.

7.3.11 Slow Start (SS/TR)

The device uses the lower voltage of the internal voltage reference or the SS/TR pin voltage as the reference voltage and regulates the output accordingly. A capacitor on the SS/TR pin to ground implements a slow start time. The device has an internal pullup current source of 2.3 μA that charges the external slow-start capacitor. The calculations for the slow start time (t_{SS} , 10% to 90%) and slow-start capacitor (C_{SS}) are shown in [Equation 4](#). The voltage reference (V_{ref}) is 0.6 V and the slow start charge current (I_{SS}) is 2.3 μA.

$$t_{SS} \text{ (ms)} = \frac{C_{SS} \text{ (nF)} \times V_{ref} \text{ (V)}}{I_{SS} \text{ (\mu A)}} \quad (4)$$

When the input UVLO is triggered, the EN pin is pulled below 1.21 V, or a thermal shutdown event occurs the device stops switching and enters low current operation. At the subsequent power up, when the shutdown condition is removed, the device does not start switching until it has discharged its SS/TR pin to ground ensuring proper soft start behavior.

7.3.12 Power Good (PWRGD)

The PWRGD pin is an open-drain output. Once the VSENSE pin is between 94% and 104% of the internal voltage reference the PWRGD pin pulldown is deasserted and the pin floats. TI recommends using a pullup resistor from the values of 10 kΩ to 100 kΩ to a voltage source that is 5.5 V or less. The PWRGD is in a defined state once the VIN input voltage is greater than 1 V but with reduced current sinking capability. The PWRGD achieves full current sinking capability once the VIN input voltage is above 4.5 V.

The PWRGD pin is pulled low when VSENSE is lower than 92% or greater than 106% of the nominal internal reference voltage. Also, the PWRGD is pulled low, if the input UVLO or thermal shutdown are asserted, the EN pin is pulled low or the SS/TR pin is below 1.4 V.

7.3.13 Output Overvoltage Protection (OVP)

The device incorporates an output overvoltage protection (OVP) circuit to minimize output voltage overshoot. For example, when the power supply output is overloaded the error amplifier compares the actual output voltage to the internal reference voltage. If the VSENSE pin voltage is lower than the internal reference voltage for a considerable time, the output of the error amplifier demands maximum output current. Once the condition is removed, the regulator output rises and the error amplifier output transitions to the steady state voltage. In some applications with small output capacitance, the power supply output voltage can respond faster than the error amplifier. This leads to the possibility of an output overshoot. The OVP feature minimizes the overshoot by comparing the VSENSE pin voltage to the OVP threshold. If the VSENSE pin voltage is greater than the OVP threshold the high-side MOSFET is turned off preventing current from flowing to the output and minimizing output overshoot. When the VSENSE voltage drops lower than the OVP threshold, the high-side MOSFET is allowed to turn on at the next clock cycle.

7.3.14 Overcurrent Protection

The device is protected from overcurrent conditions by cycle-by-cycle current limiting on both the high-side MOSFET and the low-side MOSFET.

7.3.14.1 High-Side MOSFET Overcurrent Protection

The device implements current mode control which uses the COMP pin voltage to control the turnoff of the high-side MOSFET and the turnon of the low-side MOSFET on a cycle-by-cycle basis. Each cycle the switch current and the current reference generated by the COMP pin voltage are compared, when the peak switch current intersects the current reference the high-side switch is turned off.

7.3.14.2 Low-Side MOSFET Overcurrent Protection

While the low-side MOSFET is turned on its conduction current is monitored by the internal circuitry. During normal operation the low-side MOSFET sources current to the load. At the end of every clock cycle, the low-side MOSFET sourcing current is compared to the internally set low-side sourcing current limit. If the low-side sourcing current is exceeded the high-side MOSFET is not turned on and the low-side MOSFET stays on for the next cycle. The high-side MOSFET is turned on again when the low-side current is below the low-side sourcing current limit at the start of a cycle.

The low-side MOSFET may also sink current from the load. If the low-side sinking current limit is exceeded the low-side MOSFET is turned off immediately for the rest of that clock cycle. In this scenario both MOSFETs are off until the start of the next cycle.

Furthermore, if an output overload condition (as measured by the COMP pin voltage) has lasted for more than the hiccup wait time which is programmed for 512 switching cycles, the device will shut down itself and restart

after the hiccup time of 16384 cycles. The hiccup mode helps to reduce the device power dissipation under severe overcurrent conditions.

7.3.15 Thermal Shutdown

The internal thermal shutdown circuitry forces the device to stop switching if the junction temperature exceeds 175°C typically. Once the junction temperature drops below 165°C typically, the internal thermal hiccup timer will start to count. The device reinitiates the power-up sequence after the built-in thermal shutdown hiccup time (16384 cycles) is over.

7.3.16 Small Signal Model for Loop Response

Figure 7-4 shows an equivalent model for the device control loop which can be modeled in a circuit simulation program to check frequency response and transient responses. The error amplifier is a transconductance amplifier with a g_m of 1300 $\mu\text{A/V}$. The error amplifier can be modeled using an ideal voltage controlled current source. The resistor $R_{\text{OUT(ea)}}$ (2.38 M Ω) and capacitor $C_{\text{OUT(ea)}}$ (20.7 pF) model the open loop gain and frequency response of the error amplifier. The 1-mV AC voltage source between the nodes a and b effectively breaks the control loop for the frequency response measurements. Plotting a/c and c/b show the small signal responses of the power stage and frequency compensation respectively. Plotting a/b shows the small signal response of the overall loop. The dynamic loop response can be checked by replacing the R_L with a current source with the appropriate load step amplitude and step rate in a time domain analysis.

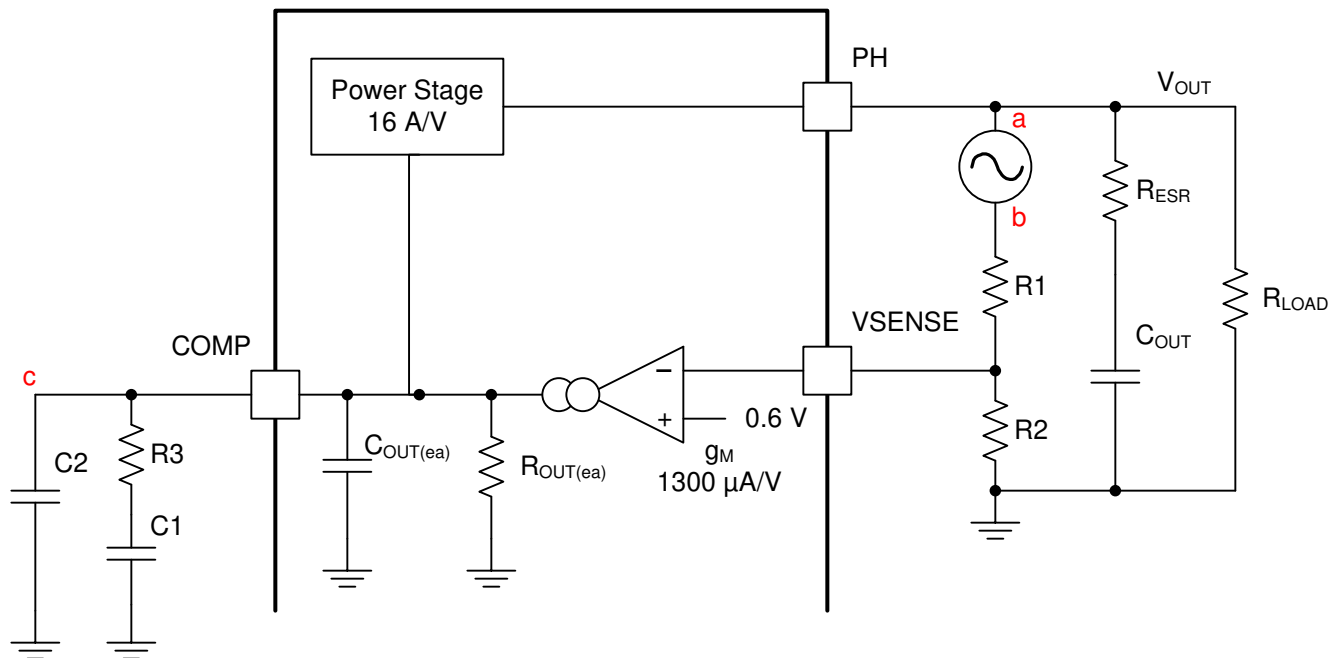

Copyright © 2016, Texas Instruments Incorporated

Figure 7-4. Small Signal Model for Loop Response

7.3.17 Simple Small Signal Model for Peak Current Mode Control

Figure 7-5 is a simple small signal model that can be used to understand how to design the frequency compensation. The device power stage can be approximated to a voltage controlled current source (duty cycle modulator) supplying current to the output capacitor and load resistor. The control to output transfer function is shown in Equation 5 and consists of a DC gain, one dominant pole and one ESR zero. The quotient of the change in switch current and the change in COMP pin voltage (node c in Figure 7-4) is the power stage transconductance ($g_{m_{ps}}$) which is 16 A/V for the device. The DC gain of the power stage is the product of $g_{m_{ps}}$ and the load resistance R_L as shown in Equation 6 with resistive loads. As the load current increases, the DC gain decreases. This variation with load may seem problematic at first glance, but fortunately the dominant pole moves with load current (see Equation 7). The combined effect is highlighted by the dashed line in Figure 7-6.

As the load current decreases, the gain increases and the pole frequency lowers, keeping the 0-dB crossover frequency the same for the varying load conditions which makes it easier to design the frequency compensation.

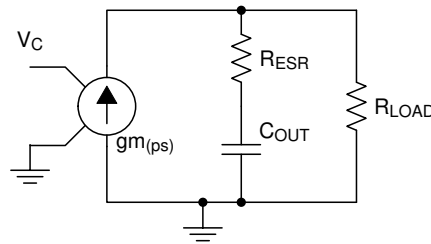

Copyright © 2016, Texas Instruments Incorporated

Figure 7-5. Simplified Small Signal Model for Peak Current Mode Control

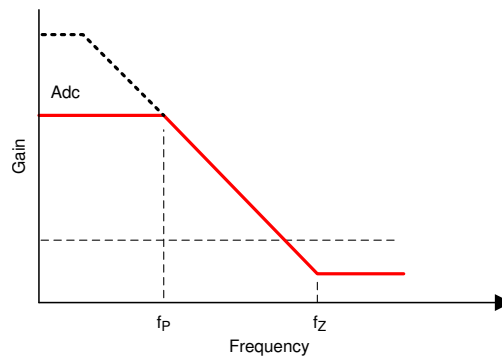

Figure 7-6. Simplified Frequency Response for Peak Current Mode Control

$$\frac{V_{OUT}}{V_C} = A_{dc} \times \frac{\left(1 + \frac{s}{2\pi \times f_z}\right)}{\left(1 + \frac{s}{2\pi \times f_p}\right)} \quad (5)$$

$$A_{dc} = g_{m_{ps}} \times R_L \quad (6)$$

where

- $g_{m_{ps}}$ is the power stage gain (16 A/V).
- R_L is the load resistance.

$$f_p = \frac{1}{C_O \times R_L \times 2\pi} \quad (7)$$

where

- C_O is the output capacitance.
- R_L is the load resistance.

$$f_z = \frac{1}{C_O \times R_{ESR} \times 2\pi} \quad (8)$$

where

- C_O is the output capacitance.
- R_{ESR} is the equivalent series resistance of the output capacitor.

7.3.18 Small Signal Model for Frequency Compensation

The device uses a transconductance amplifier for the error amplifier and readily supports two of the commonly used Type II compensation circuits and a Type III frequency compensation circuit, as shown in Figure 7-7. In Type 2A, one additional high-frequency pole, C6, is added to attenuate high frequency noise. In Type III, one additional capacitor, C11, is added to provide a phase boost at the crossover frequency. See [Designing Type III Compensation for Current Mode Step-Down Converters](#) for a complete explanation of Type III compensation.

The design guidelines below are provided for advanced users who prefer to compensate using the general method. The following equations only apply to designs whose ESR zero is above the bandwidth of the control loop. This is usually true with ceramic output capacitors. See [Application and Implementation](#) for a step-by-step design procedure using higher ESR output capacitors with lower ESR zero frequencies.

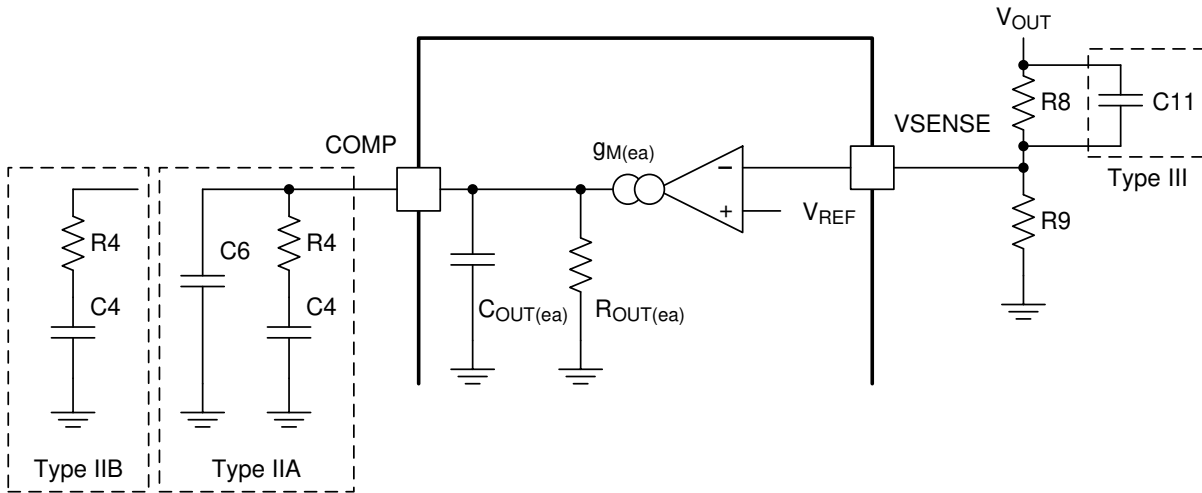

Copyright © 2016, Texas Instruments Incorporated

Figure 7-7. Types of Frequency Compensation

The general design guidelines for device loop compensation are as follows:

1. Determine the crossover frequency, f_c . A good starting point is $1/10^{\text{th}}$ of the switching frequency, f_{sw} .
2. R4 can be determined by:

$$R4 = \frac{2\pi \times f_c \times V_{OUT} \times C_o}{g_{m_{ea}} \times V_{ref} \times g_{m_{ps}}} \quad (9)$$

where

- $g_{m_{ea}}$ is the GM amplifier gain (1300 $\mu\text{A/V}$).
- $g_{m_{ps}}$ is the power stage gain (16 A/V).
- V_{ref} is the reference voltage (0.6 V).

3. Place a compensation zero at the dominant pole: $\left(f_p = \frac{1}{C_o \times R_L \times 2\pi} \right)$
C4 can be determined by:

$$C4 = \frac{R_L \times C_o}{R4} \quad (10)$$

4. C6 is optional. It can be used to cancel the zero from the equivalent series resistance (ESR) of the output capacitor C_o .

$$C6 = \frac{R_{ESR} \times C_o}{R4} \quad (11)$$

5. Type III compensation can be implemented with the addition of one capacitor, C11. This allows for slightly higher loop bandwidths and higher phase margins. If used, C11 is calculated from [Equation 12](#).

$$C11 = \frac{1}{(2 \cdot \pi \cdot R8 \cdot f_c)} \quad (12)$$

7.4 Device Functional Modes

7.4.1 Adjustable Switching Frequency (RT Mode)

To determine the RT resistance for a given switching frequency, use [Equation 13](#) or the curve in [Figure 7-8](#). To reduce the solution size one would set the switching frequency as high as possible, but tradeoffs of the supply efficiency and minimum controllable on-time should be considered.

$$R_{rt}(k\Omega) = 48000 \cdot F_{sw} (kHz)^{-0.997} - 2 \quad (13)$$

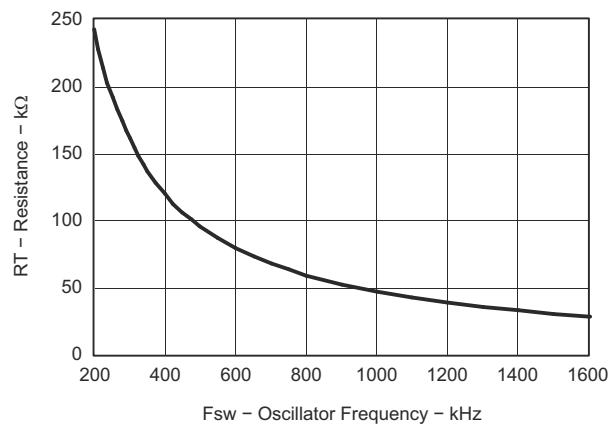

Figure 7-8. RT Set Resistor vs Switching Frequency

7.4.2 Synchronization (CLK Mode)

An internal phase locked loop (PLL) has been implemented to allow synchronization from 200 kHz to 1600 kHz, and to easily switch from RT mode to CLK mode.

To implement the synchronization feature, connect a square wave clock signal to the RT/CLK pin with a duty cycle from 20% to 80%. The clock signal amplitude must transition lower than 0.8 V and higher than 2 V. The start of the switching cycle is synchronized to the falling edge of RT/CLK pin.

In applications where both RT mode and CLK mode are needed, the device can be configured as shown in [Figure 7-9](#). Before the external clock is present, the device works in RT mode and the switching frequency is set by RT resistor. When the external clock is present, the CLK mode overrides the RT mode. The first time the SYNC pin is pulled above the RT/CLK high threshold (2 V), the device switches from the RT mode to the CLK mode and the RT/CLK pin becomes high impedance as the PLL starts to lock onto the frequency of the external clock. TI does not recommend switching from the CLK mode back to the RT mode because the internal switching frequency drops to 100 kHz first before returning to the switching frequency set by RT resistor.

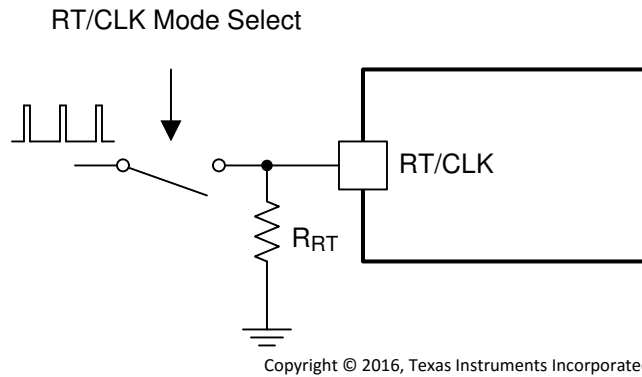

Figure 7-9. Works With Both RT Mode and CLK Mode

7.4.3 Bootstrap Voltage (BOOT) and Low Dropout Operation

The device has an integrated boot regulator, and requires a small ceramic capacitor between the BOOT and PH pins to provide the gate drive voltage for the high-side MOSFET. The boot capacitor is charged when the BOOT pin voltage is less than V_{IN} and BOOT-PH voltage is below regulation. The value of this ceramic capacitor should be between $0.1 \mu\text{F}$ and $1 \mu\text{F}$. TI recommends a ceramic capacitor with an X7R or X5R grade dielectric with a voltage rating of 10 V or higher because of the stable characteristics over temperature and voltage.

To improve drop out, the device is designed to operate at 100% duty cycle as long as the BOOT to PH pin voltage is greater than the BOOT-PH UVLO threshold which is typically 2.1 V. When the voltage between BOOT and PH drops below the BOOT-PH UVLO threshold, the high-side MOSFET is turned off and the low-side MOSFET is turned on allowing the boot capacitor to be recharged. In applications with split input voltage rails, 100% duty cycle operation can be achieved as long as $(V_{IN} - P_{VIN}) > 4 \text{ V}$.

7.4.4 Sequencing (SS/TR)

Many of the common power supply sequencing methods can be implemented using the SS/TR, EN and PWRGD pins.

The sequential method is illustrated in [Figure 7-10](#) using two TPS54622-EP-EP devices. The power good of the first device is coupled to the EN pin of the second device which enables the second power supply once the primary supply reaches regulation.

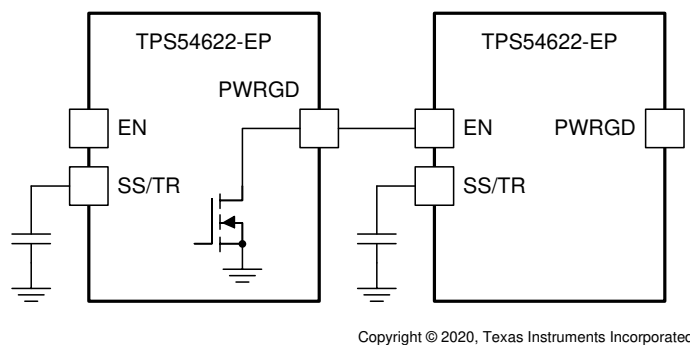
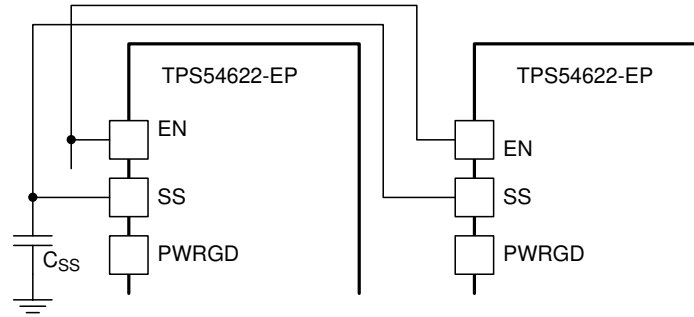

Figure 7-10. Sequential Start-Up Sequence

[Figure 7-11](#) shows the method implementing ratiometric sequencing by connecting the SS/TR pins of two devices together. The regulator outputs ramp up and reach regulation at the same time. When calculating the slow start time the pullup current source must be doubled in [Equation 4](#).



Copyright © 2020, Texas Instruments Incorporated

Figure 7-11. Ratiometric Start-Up Sequence

Ratiometric and simultaneous power supply sequencing can be implemented by connecting the resistor network of R1 and R2 shown in [Figure 7-12](#) to the output of the power supply that needs to be tracked or another voltage reference source. Using [Equation 14](#) and [Equation 15](#), the tracking resistors can be calculated to initiate the Vout2 slightly before, after or at the same time as Vout1. [Equation 16](#) is the voltage difference between Vout1 and Vout2.

To design a ratiometric start-up in which the Vout2 voltage is slightly greater than the Vout1 voltage when Vout2 reaches regulation, use a negative number in [Equation 14](#) and [Equation 15](#) for deltaV. [Equation 16](#) results in a positive number for applications where the Vout2 is slightly lower than Vout1 when Vout2 regulation is achieved. .

The deltaV variable is zero volt for simultaneous sequencing. To minimize the effect of the inherent SS/TR to VSENSE offset (Vssoffset, 29 mV) in the slow start circuit and the offset created by the pullup current source (Iss, 2.3 µA) and tracking resistors, the Vssoffset and Iss are included as variables in the equations.

To ensure proper operation of the device, the calculated R1 value from [Equation 14](#) must be greater than the value calculated in [Equation 17](#).

$$R1 = \frac{V_{out2} + \Delta V}{V_{ref}} \times \frac{V_{ssoffset}}{I_{ss}} \tag{14}$$

$$R2 = \frac{V_{ref} \times R1}{V_{out2} + \Delta V - V_{ref}} \tag{15}$$

$$\Delta V = V_{out1} - V_{out2} \tag{16}$$

$$R1 > 2800 \times V_{out1} - 180 \times \Delta V \tag{17}$$

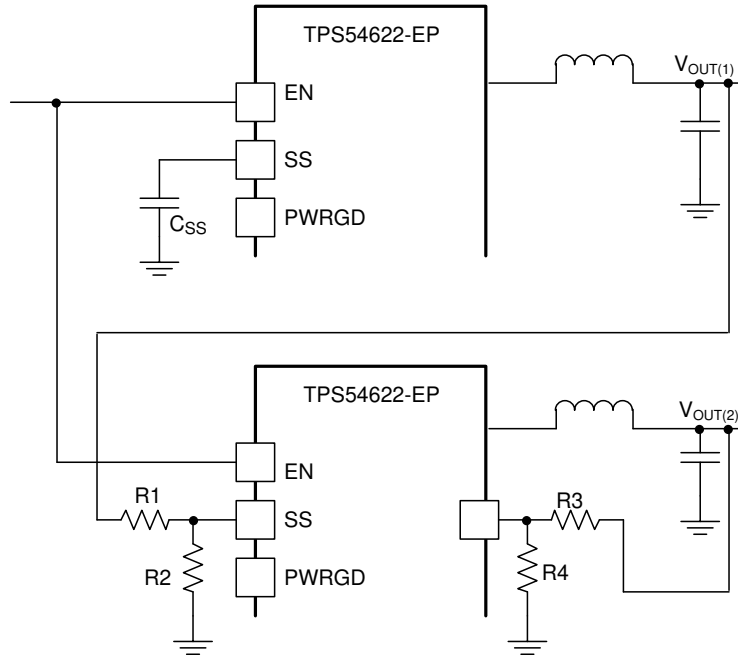

Copyright © 2020, Texas Instruments Incorporated

Figure 7-12. Ratiometric and Simultaneous Start-Up Sequence

There are two final considerations when using a resistor divider to the SS/TR pin for simultaneous start-up. First, as described in [Power Good \(PWRGD\)](#), for the PWRGD output to be active the SS/TR voltage must be above 1.4 V. The external divider may prevent the SS/TR voltage from charging above the threshold. For the SS/TR pin to charge above the threshold, an external MOSFET may be needed to disconnect the resistor divider or modify the resistor divider ratio after start-up is complete. The PWRGD pin of the $V_{OUT(1)}$ converter could be used to turn on or turn off the external MOSFET. Second, a pre-bias on $V_{OUT(1)}$ may prevent $V_{OUT(2)}$ from turning on. When the TPS54622-EP is enabled, an internal 700- Ω MOSFET at the SS/TR pin turns on to discharge the SS/TR voltage as described in [Slow Start \(SS/TR\)](#). The SS/TR pin voltage must discharge below 20 mV before the TPS54622-EP starts up. If the upper resistor at the SS/TR pin is too small, the SS/TR pin does not discharge below the threshold, and $V_{OUT(2)}$ does not ramp up. The upper resistor in the SS/TR divider may need to be increased to allow the SS/TR pin to discharge below the threshold.

8 Application and Implementation

Note

Information in the following applications sections is not part of the TI component specification, and TI does not warrant its accuracy or completeness. TI's customers are responsible for determining suitability of components for their purposes, as well as validating and testing their design implementation to confirm system functionality.

8.1 Application Information

The TPS54622-EP device is a highly integrated synchronous step-down DC-DC converter. This device is used to convert a higher DC input voltage to a lower DC output voltage with a maximum output current of 6 A.

8.2 Typical Application

The application schematic of [Figure 8-1](#) was developed to meet the requirements above. This circuit is available as the TPS54622-EP evaluation module. The design procedure is given in this section. For more information about Type II and Type III frequency compensation circuits, see [Designing Type III Compensation for Current Mode Step-Down Converters](#) and design calculator ([SLVC219](#)).

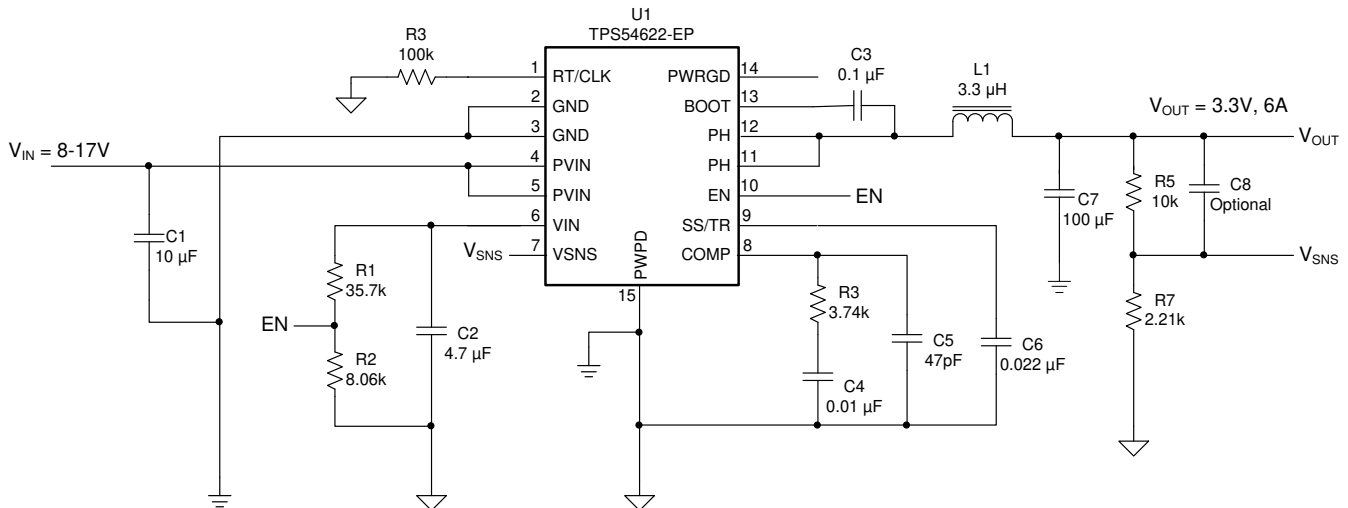

Figure 8-1. Typical Application Circuit

8.2.1 Design Requirements

This example details the design of a high-frequency switching regulator design using ceramic output capacitors. A few parameters must be known to start the design process. These parameters are typically determined at the system level. For this example, begin with the known parameters listed in [Table 8-1](#).

Table 8-1. Design Parameters

DESIGN PARAMETER	EXAMPLE VALUE
Output voltage	3.3 V
Output current	6 A
Transient response 1-A load step	$\Delta V_{OUT} = 5\%$
Input voltage	12 V nominal, 8 V to 17 V
Output voltage ripple	33 mV p-p
Start input voltage (rising V_{IN})	6.528 V
Stop input voltage (falling V_{IN})	6.190 V
Switching frequency	480 kHz

8.2.2 Detailed Design Procedures

8.2.2.1 Custom Design With WEBENCH® Tools

[Click here](#) to create a custom design using the TPS54622-EP device with the WEBENCH® Power Designer.

1. Start by entering the input voltage (V_{IN}), output voltage (V_{OUT}), and output current (I_{OUT}) requirements.
2. Optimize the design for key parameters such as efficiency, footprint, and cost using the optimizer dial.
3. Compare the generated design with other possible solutions from Texas Instruments.

The WEBENCH Power Designer provides a customized schematic along with a list of materials with real-time pricing and component availability.

In most cases, these actions are available:

- Run electrical simulations to see important waveforms and circuit performance
- Run thermal simulations to understand board thermal performance
- Export customized schematic and layout into popular CAD formats
- Print PDF reports for the design, and share the design with colleagues

Get more information about WEBENCH tools at www.ti.com/WEBENCH.

8.2.2.2 Operating Frequency

The first step is to decide on a switching frequency for the regulator. There is a trade off between higher and lower switching frequencies. Higher switching frequencies may produce smaller a solution size using lower valued inductors and smaller output capacitors compared to a power supply that switches at a lower frequency. However, the higher switching frequency causes extra switching losses, which hurt the converter's efficiency and thermal performance. In this design, a moderate switching frequency of 480 kHz is selected to achieve both a small solution size and a high-efficiency operation.

8.2.2.3 Output Inductor Selection

To calculate the value of the output inductor, use [Equation 18](#). $KIND$ is a coefficient that represents the amount of inductor ripple current relative to the maximum output current. The inductor ripple current is filtered by the output capacitor. Therefore, choosing high inductor ripple currents impact the selection of the output capacitor since the output capacitor must have a ripple current rating equal to or greater than the inductor ripple current. In general, the inductor ripple value is at the discretion of the designer; however, $KIND$ is normally from 0.1 to 0.3 for the majority of applications.

$$L1 = \frac{V_{inmax} - V_{out}}{I_o \cdot KIND} \cdot \frac{V_{out}}{V_{inmax} \cdot f_{sw}} \quad (18)$$

For this design example, use $KIND = 0.3$ and the inductor value is calculated to be 3.08 μH . For this design, a nearest standard value was chosen: 3.3 μH . For the output filter inductor, it is important that the RMS current and saturation current ratings not be exceeded. The RMS and peak inductor current can be found from [Equation 20](#) and [Equation 21](#).

$$I_{ripple} = \frac{V_{inmax} - V_{out}}{L1} \cdot \frac{V_{out}}{V_{inmax} \cdot f_{sw}} \quad (19)$$

$$I_{Lrms} = \sqrt{I_o^2 + \frac{1}{12} \cdot \left(\frac{V_o \cdot (V_{inmax} - V_o)}{V_{inmax} \cdot L1 \cdot f_{sw}} \right)^2} \quad (20)$$

$$I_{Lpeak} = I_{out} + \frac{I_{ripple}}{2} \quad (21)$$

For this design, the RMS inductor current is 6.02 A and the peak inductor current is 6.84 A. The chosen inductor is a Coilcraft MSS1048 series 3.3 μH . It has a saturation current rating of 7.38 A and a RMS current rating of 7.22 A.

The current flowing through the inductor is the inductor ripple current plus the output current. During power-up, faults or transient load conditions, the inductor current can increase above the calculated peak inductor current level calculated above. In transient conditions, the inductor current can increase up to the switch current limit of the device. For this reason, the most conservative approach is to specify an inductor with a saturation current rating equal to or greater than the switch current limit rather than the peak inductor current.

8.2.2.4 Output Capacitor Selection

There are three primary considerations for selecting the value of the output capacitor. The output capacitor determines the modulator pole, the output voltage ripple, and how the regulator responds to a large change in load current. The output capacitance needs to be selected based on the more stringent of these three criteria.

The desired response to a large change in the load current is the first criteria. The output capacitor needs to supply the load with current when the regulator can not. This situation would occur if there are desired hold-up times for the regulator where the output capacitor must hold the output voltage above a certain level for a specified amount of time after the input power is removed. The regulator is also temporarily not able to supply sufficient output current if there is a large, fast increase in the current needs of the load such as a transition from no load to full load. The regulator usually needs two or more clock cycles for the control loop to see the change in load current and output voltage and adjust the duty cycle to react to the change. The output capacitor must be sized to supply the extra current to the load until the control loop responds to the load change. The output capacitance must be large enough to supply the difference in current for 2 clock cycles while only allowing a tolerable amount of droop in the output voltage. Equation 22 shows the minimum output capacitance necessary to accomplish this.

$$C_o > \frac{2 \cdot \Delta I_{\text{out}}}{f_{\text{sw}} \cdot \Delta V_{\text{out}}} \quad (22)$$

where

- ΔI_{out} is the change in output current.
- f_{sw} is the regulators switching frequency.
- ΔV_{out} is the allowable change in the output voltage.

For this example, the transient load response is specified as a 5% change in V_{out} for a load step of 1 A. For this example, $\Delta I_{\text{out}} = 3$ A and $\Delta V_{\text{out}} = 0.05 \times 3.3 = 0.165$ V. Using these numbers gives a minimum capacitance of 75.8 μF . This value does not take the ESR of the output capacitor into account in the output voltage change. For ceramic capacitors, the ESR is usually small enough to ignore in this calculation.

Equation 23 calculates the minimum output capacitance needed to meet the output voltage ripple specification. Where f_{sw} is the switching frequency, V_{ripple} is the maximum allowable output voltage ripple, and I_{ripple} is the inductor ripple current. In this case, the maximum output voltage ripple is 33 mV. Under this requirement, Equation 23 yields 13.2 μF .

$$C_o > \frac{1}{8 \cdot f_{\text{sw}}} \cdot \frac{1}{\frac{V_{\text{ripple}}}{I_{\text{ripple}}}} \quad (23)$$

Equation 24 calculates the maximum ESR an output capacitor can have to meet the output voltage ripple specification. Equation 24 indicates the ESR should be less than 19.7 m Ω . In this case, the ESR of the ceramic capacitors is much smaller than 19.7 m Ω .

$$\text{Resr} < \frac{V_{\text{ripple}}}{I_{\text{ripple}}} \quad (24)$$

Additional capacitance deratings for aging, temperature and DC bias should be factored in which increases this minimum value. For this example, a 100- μF , 6.3-V X5R ceramic capacitor with 3 m Ω of ESR is used. Capacitors generally have limits to the amount of ripple current they can handle without failing or producing excess heat. An output capacitor that can support the inductor ripple current must be specified. Some capacitor data sheets specify the RMS (Root Mean Square) value of the maximum ripple current. Equation 25 can be used to calculate the RMS ripple current the output capacitor needs to support. For this application, Equation 25 yields 485 mA.

$$I_{\text{corms}} = \frac{V_{\text{out}} \cdot (V_{\text{inmax}} - V_{\text{out}})}{\sqrt{12} \cdot V_{\text{inmax}} \cdot L_1 \cdot f_{\text{sw}}} \quad (25)$$

8.2.2.5 Input Capacitor Selection

The TPS54622-EP requires a high-quality ceramic, type X5R or X7R, input decoupling capacitor of at least 4.7 μF of effective capacitance on the PVIN input voltage pins and 4.7 μF on the Vin input voltage pin. In some applications, additional bulk capacitance may also be required for the PVIN input. The effective capacitance includes any DC bias effects. The voltage rating of the input capacitor must be greater than the maximum input voltage. The capacitor must also have a ripple current rating greater than the maximum input current ripple of the TPS54622-EP. The input ripple current can be calculated using Equation 26.

$$I_{\text{cirms}} = I_{\text{out}} \cdot \sqrt{\frac{V_{\text{out}}}{V_{\text{inmin}}} \cdot \frac{(V_{\text{inmin}} - V_{\text{out}})}{V_{\text{inmin}}}} \quad (26)$$

The value of a ceramic capacitor varies significantly over temperature and the amount of DC bias applied to the capacitor. The capacitance variations due to temperature can be minimized by selecting a dielectric material that is stable over temperature. X5R and X7R ceramic dielectrics are usually selected for power regulator capacitors because they have a high capacitance to volume ratio and are fairly stable over temperature. The output capacitor must also be selected with the DC bias taken into account. The capacitance value of a capacitor decreases as the DC bias across a capacitor increases. For this example design, a ceramic capacitor with at least a 25 V voltage rating is required to support the maximum input voltage. For this example, one 10 μF and one 4.7 μF 25-V capacitors in parallel have been selected as the VIN and PVIN inputs are tied together so the TPS54622-EP may operate from a single supply. The input capacitance value determines the input ripple voltage of the regulator. The input voltage ripple can be calculated using Equation 27. Using the design example values, $I_{\text{outmax}} = 6$ A, $C_{\text{in}} = 14.7$ μF , $f_{\text{sw}} = 480$ kHz, yields an input voltage ripple of 213 mV and a RMS input ripple current of 2.95 A.

$$\Delta V_{\text{in}} = \frac{I_{\text{outmax}} \cdot 0.25}{C_{\text{in}} \cdot f_{\text{sw}}} \quad (27)$$

8.2.2.6 Slow-Start Capacitor Selection

The slow-start capacitor determines the minimum amount of time it takes for the output voltage to reach its nominal programmed value during power up. This is useful if a load requires a controlled voltage slew rate. This is also used if the output capacitance is very large and would require large amounts of current to quickly charge the capacitor to the output voltage level. The large currents necessary to charge the capacitor may make the TPS54622-EP reach the current limit or excessive current draw from the input power supply may cause the input voltage rail to sag. Limiting the output voltage slew rate solves both of these problems. The soft-start capacitor value can be calculated using Equation 28. For the example circuit, the soft-start time is not too critical since the output capacitor value is 100 μF which does not require much current to charge to 3.3 V. The example circuit has the soft-start time set to an arbitrary value of 6 ms which requires a 22-nF capacitor. In TPS54622-EP, I_{ss} is 2.3 μA and V_{ref} is 0.6 V.

$$C_6(\text{nF}) = \frac{T_{\text{ss}}(\text{ms}) \cdot I_{\text{ss}}(\mu\text{A})}{V_{\text{ref}}(\text{V})} \quad (28)$$

8.2.2.7 Bootstrap Capacitor Selection

A 0.1- μ F to 1- μ F ceramic capacitor must be connected between the BOOT to PH pin for proper operation. TI recommends using a ceramic capacitor with X5R or better grade dielectric. The capacitor should have 10-V or higher voltage rating.

8.2.2.8 Undervoltage Lockout Setpoint

The undervoltage lockout (UVLO) can be adjusted using the external voltage divider network of R3 and R4. R3 is connected between VIN and the EN pin of the TPS54622-EP and R4 is connected between EN and GND. The UVLO has two thresholds, one for power up when the input voltage is rising and one for power down or brownouts when the input voltage is falling. For the example design, the supply should turn on and start switching once the input voltage increases above 6.528 V (UVLO start or enable). After the regulator starts switching, it should continue to do so until the input voltage falls below 6.19 V (UVLO stop or disable). [Equation 2](#) and [Equation 3](#) can be used to calculate the values for the upper and lower resistor values. For the stop voltages specified, the nearest standard resistor value for R3 is 35.7 k Ω and for R4 is 8.06 k Ω .

8.2.2.9 Output Voltage Feedback Resistor Selection

The resistor-divider network R5 and R6 is used to set the output voltage. For the example design, 10 k Ω was selected for R5. Using [Equation 29](#), R6 is calculated as 2.22 k Ω . The nearest standard 1% resistor is 2.21 k Ω .

$$R6 = \frac{R5 \cdot V_{ref}}{V_o - V_{ref}} \quad (29)$$

8.2.2.9.1 Minimum Output Voltage

Due to the internal design of the TPS54622-EP, there is a minimum output voltage limit for any given input voltage. The output voltage can never be lower than the internal voltage reference of 0.6 V. Above 0.6 V, the output voltage may be limited by the minimum controllable on-time. The minimum output voltage in this case is given by [Equation 30](#):

$$V_{outmin} = O_{ntimemin} \cdot F_{smax} (V_{inmax} + I_{outmin} (R_{DS2min} - R_{DS1min})) - I_{outmin} (R_L + R_{DS2min}) \quad (30)$$

where

- V_{outmin} = minimum achievable output voltage
- $O_{ntimemin}$ = minimum controllable on-time (135-ns maximum)
- F_{smax} = maximum switching frequency including tolerance
- V_{inmax} = maximum input voltage
- I_{outmin} = minimum load current
- R_{DS1min} = minimum high-side MOSFET ON-resistance (36-32-m Ω typical)
- R_{DS2min} = minimum low-side MOSFET ON-resistance (19-m Ω typical)
- R_L = series resistance of output inductor

8.2.2.10 Compensation Component Selection

There are several industry techniques used to compensate DC-DC regulators. The method presented here is easy to calculate and yields high phase margins. For most conditions, the regulator has a phase margin from 60 to 90 degrees. The method presented here ignores the effects of the slope compensation that is internal to the TPS54622-EP. Since the slope compensation is ignored, the actual crossover frequency is usually lower than the crossover frequency used in the calculations.

First, the modulator pole, f_{pmod} , and the ESR zero, f_{zmod} , must be calculated using [Equation 31](#) and [Equation 32](#). For C_{out} , use a derated value of 75 μ F. Use [Equation 33](#) and [Equation 34](#) to estimate a starting point for the closed loop crossover frequency, f_{co} . Then the required compensation components may be derived. For this design example, f_{pmod} is 3.86 kHz and f_{zmod} is 707.4 kHz. Equation 33 is the geometric mean of the modulator pole and the ESR zero and Equation 34 is the geometric mean of the modulator pole and one half the switching frequency. Use a frequency near the lower of these two values as the intended crossover frequency, f_{co} . In this

case Equation 33 yields 52.2 kHz and Equation 34 yields 30.4 kHz. The lower value is 30.4 kHz. A slightly higher frequency of 30 kHz is chosen as the intended crossover frequency.

$$f_{pmod} = \frac{I_{out}}{2 \cdot \pi \cdot V_{out} \cdot C_{out}} \quad (31)$$

$$f_{zmod} = \frac{1}{2 \cdot \pi \cdot RESR \cdot C_{out}} \quad (32)$$

$$f_{co} = \sqrt{f_{pmod} \cdot f_{zmod}} \quad (33)$$

$$f_{co} = \sqrt{f_{pmod} \cdot \frac{f_{sw}}{2}} \quad (34)$$

Now the compensation components can be calculated. First calculate the value for R2 which sets the gain of the compensated network at the crossover frequency. Use [Equation 35](#) to determine the value of R2.

$$R4 = \frac{2\pi \cdot f_c \cdot V_{out} \cdot C_{out}}{g_{m_{ea}} \cdot V_{ref} \cdot g_{m_{ps}}} \quad (35)$$

Next calculate the value of C3. Together with R2, C3 places a compensation zero at the modulator pole frequency. [Equation 36](#) to determine the value of C3.

$$C4 = \frac{V_{out} \cdot C_{out}}{I_{out} \cdot R4} \quad (36)$$

Using Equation 35 and Equation 36 the standard values for R4 and C4 are 3.74 kΩ and 0.01 μF.

An additional high-frequency pole can be used if necessary by adding a capacitor in parallel with the series combination of R4 and C4. The pole frequency can be placed at the ESR zero frequency of the output capacitor as given by [Equation 8](#). Use [Equation 37](#) to calculate the required capacitor value for C5.

$$C5 = \frac{RESR \cdot C_{out}}{R4} \quad (37)$$

8.2.2.11 Fast Transient Considerations

In applications where fast transient responses are very important, Type III frequency compensation can be used instead of the traditional Type II frequency compensation.

For more information about Type II and Type III frequency compensation circuits, see [Designing Type III Compensation for Current Mode Step-Down Converters](#) and design calculator ([SLVC219](#)).

8.2.3 Application Curves

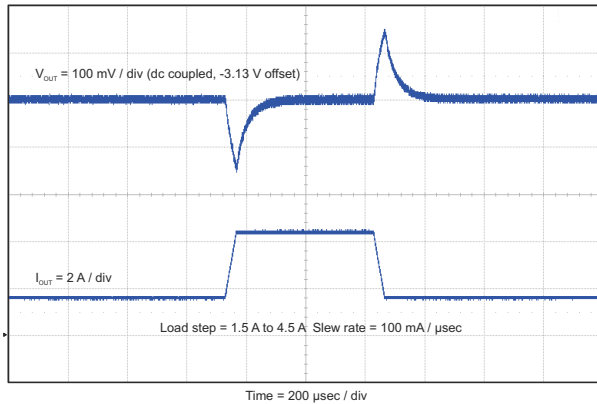

Figure 8-2. Load Transient

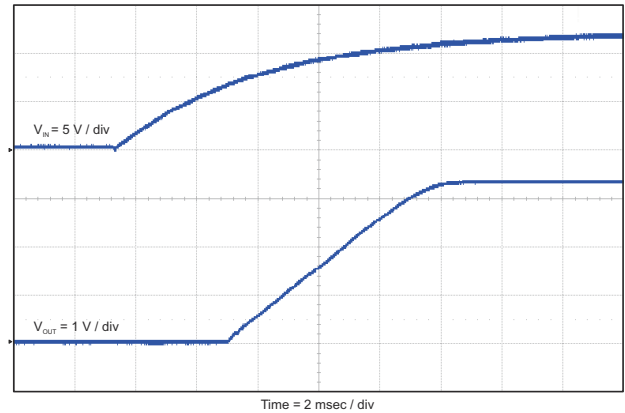

Figure 8-3. Start-Up With VIN

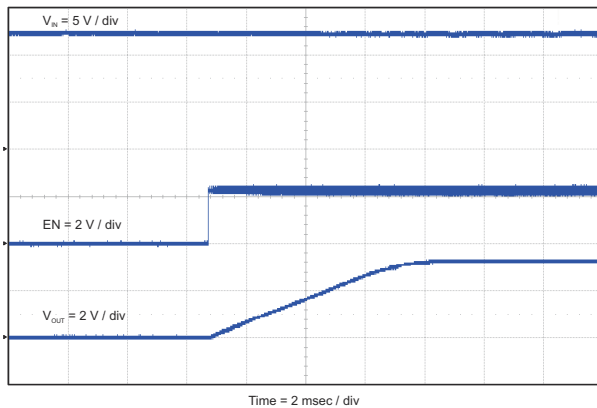

Figure 8-4. Start-Up With EN

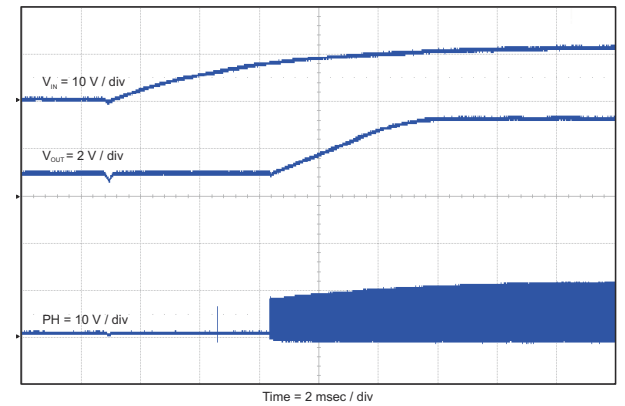

Figure 8-5. Start-Up With PRE-BIAS

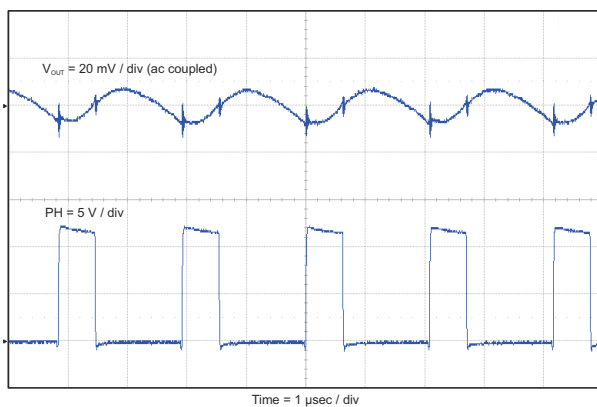

Figure 8-6. Output Voltage Ripple With No Load

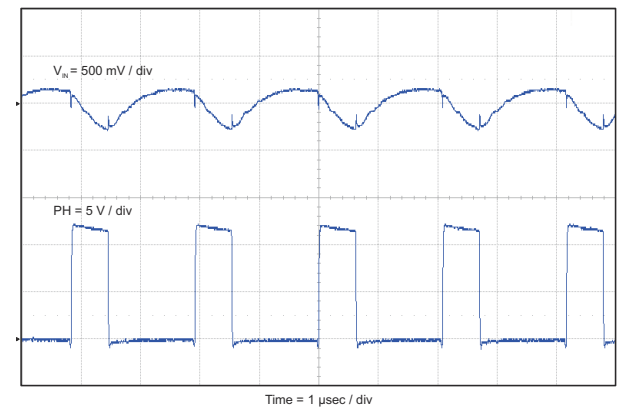

Figure 8-7. Input Voltage Ripple With Full Load

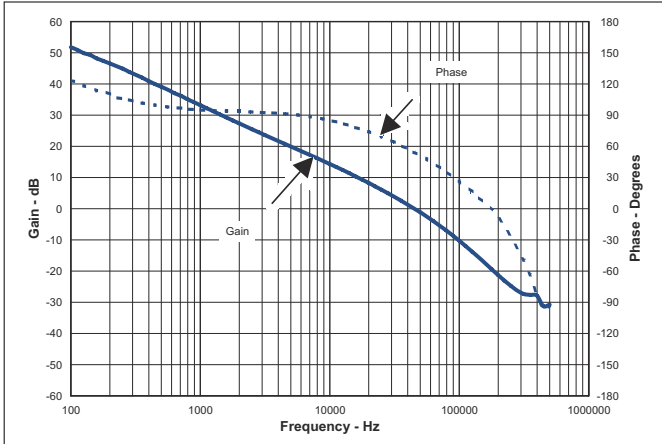

Figure 8-8. Closed Loop Response

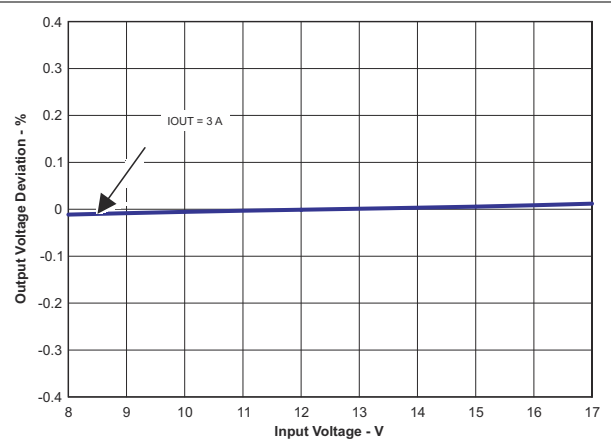

Figure 8-9. Line Regulation

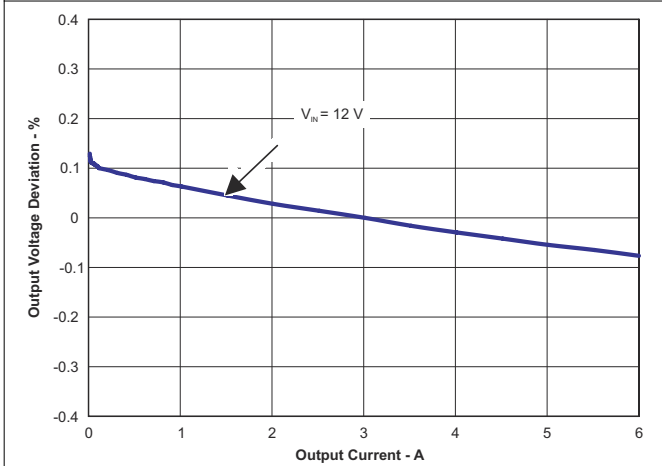

Figure 8-10. Load Regulation

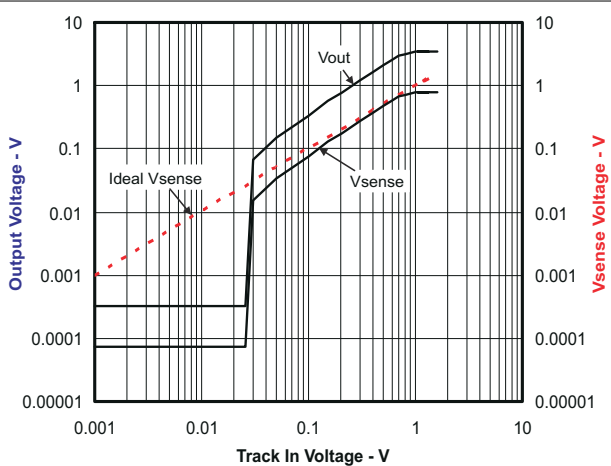

Figure 8-11. Tracking Performance

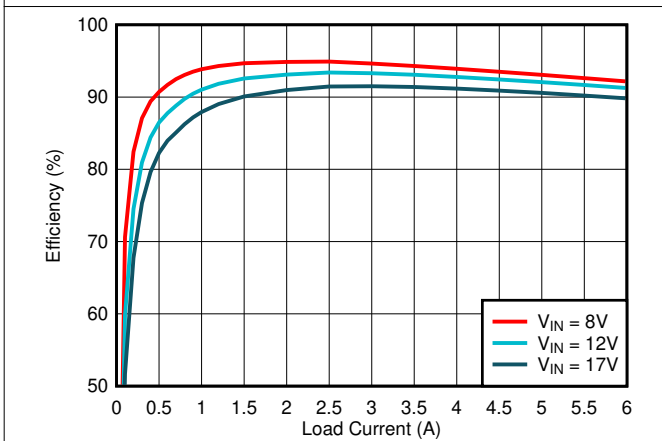

Figure 8-12. Efficiency vs Load Current

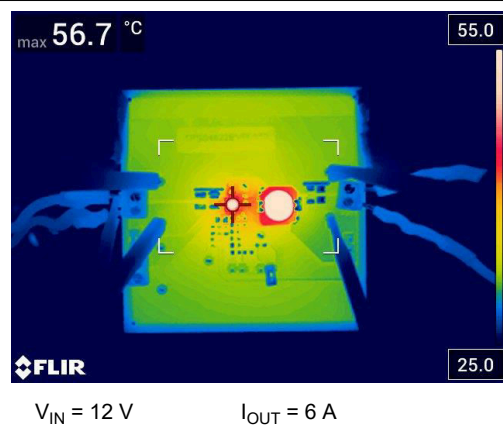

Figure 8-13. Thermal Image

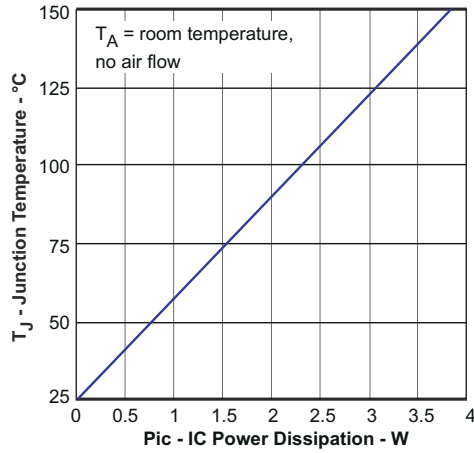

Figure 8-14. Junction Temperature vs IC Power Dissipation

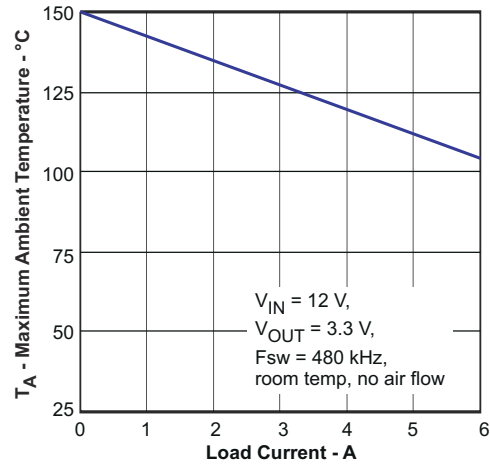

Figure 8-15. Maximum Ambient Temperature vs Load Current

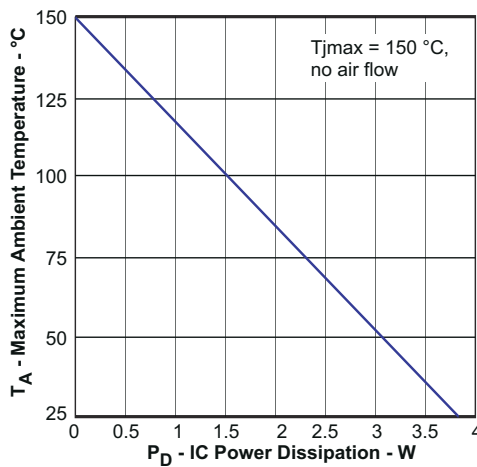

Figure 8-16. Maximum Ambient Temperature vs IC Power Dissipation

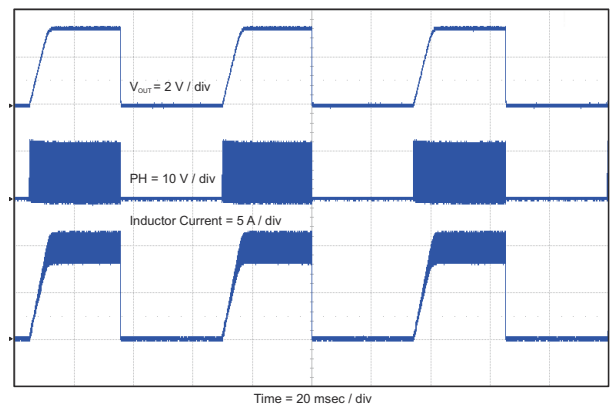

Figure 8-17. Hiccup Mode Current Limit

9 Power Supply Recommendations

The TPS54622-EP is designed to operate from an input voltage supply range from 4.5 V to 17 V. This supply voltage must be well regulated. Power supplies must be well bypassed for proper electrical performance. This includes a minimum of one 4.7- μ F (after derating) ceramic capacitor, type X5R or better from PVIN to GND, and from VIN to GND. Additional local ceramic bypass capacitance may be required in systems with small input ripple specifications, in addition to bulk capacitance if the TPS54622-EP device is located more than a few inches away from its input power supply. In systems with an auxiliary power rail available, the power stage input, PVIN, and the analog power input, VIN, may operate from separate input supplies. See [Figure 10-1](#) for recommended bypass capacitor placement.

10 Layout

10.1 Layout Guidelines

- Layout is a critical portion of good power supply design. See [Figure 10-1](#) for a PCB layout example.
- The top layer contains the main power traces for VIN, VOUT, and VPHASE. Also on the top layer are connections for the remaining pins of the TPS54622-EP and a large top-side area filled with ground.
- Connect the top layer ground area to the internal ground layers using vias at the input bypass capacitor, the output filter capacitor, and directly under the TPS54622-EP device to provide a thermal path from the exposed thermal pad land to ground.
- Tie the GND pin directly to the power pad under the IC and the power pad.
- For operation at full rated load, the top side ground area together with the internal ground plane, must provide adequate heat dissipating area.
- There are several signals paths that conduct fast changing currents or voltages that can interact with stray inductance or parasitic capacitance to generate noise or degrade the power supplies performance.
- To help eliminate these problems, the PVIN pin should be bypassed to ground with a low ESR ceramic bypass capacitor with X5R or X7R dielectric.
- Care should be taken to minimize the loop area formed by the bypass capacitor connections, the PVIN pins, and the ground connections.
- The VIN pin must also be bypassed to ground using a low ESR ceramic capacitor with X5R or X7R dielectric.
- Make sure to connect this capacitor to the quiet analog ground trace rather than the power ground trace of the PVIn bypass capacitor.
- Since the PH connection is the switching node, the output inductor should be located close to the PH pins, and the area of the PCB conductor minimized to prevent excessive capacitive coupling.
- The output filter capacitor ground should use the same power ground trace as the PVIN input bypass capacitor.
- Try to minimize this conductor length while maintaining adequate width.
- The small signal components should be grounded to the analog ground path as shown.
- The RT/CLK pin is sensitive to noise so the RT resistor must be located as close as possible to the IC and routed with minimal lengths of trace.
- The additional external components can be placed approximately as shown.
- It may be possible to obtain acceptable performance with alternate PCB layouts, however, this layout has been shown to produce good results and is meant as a guideline.
- Land pattern and stencil information is provided in the data sheet addendum.
- The dimension and outline information is for the standard RHL (S-PVQFN-N14) package.
- There may be slight differences between the provided data and actual lead frame used on the TPS54622-EPRHL package.

10.2 Layout Examples

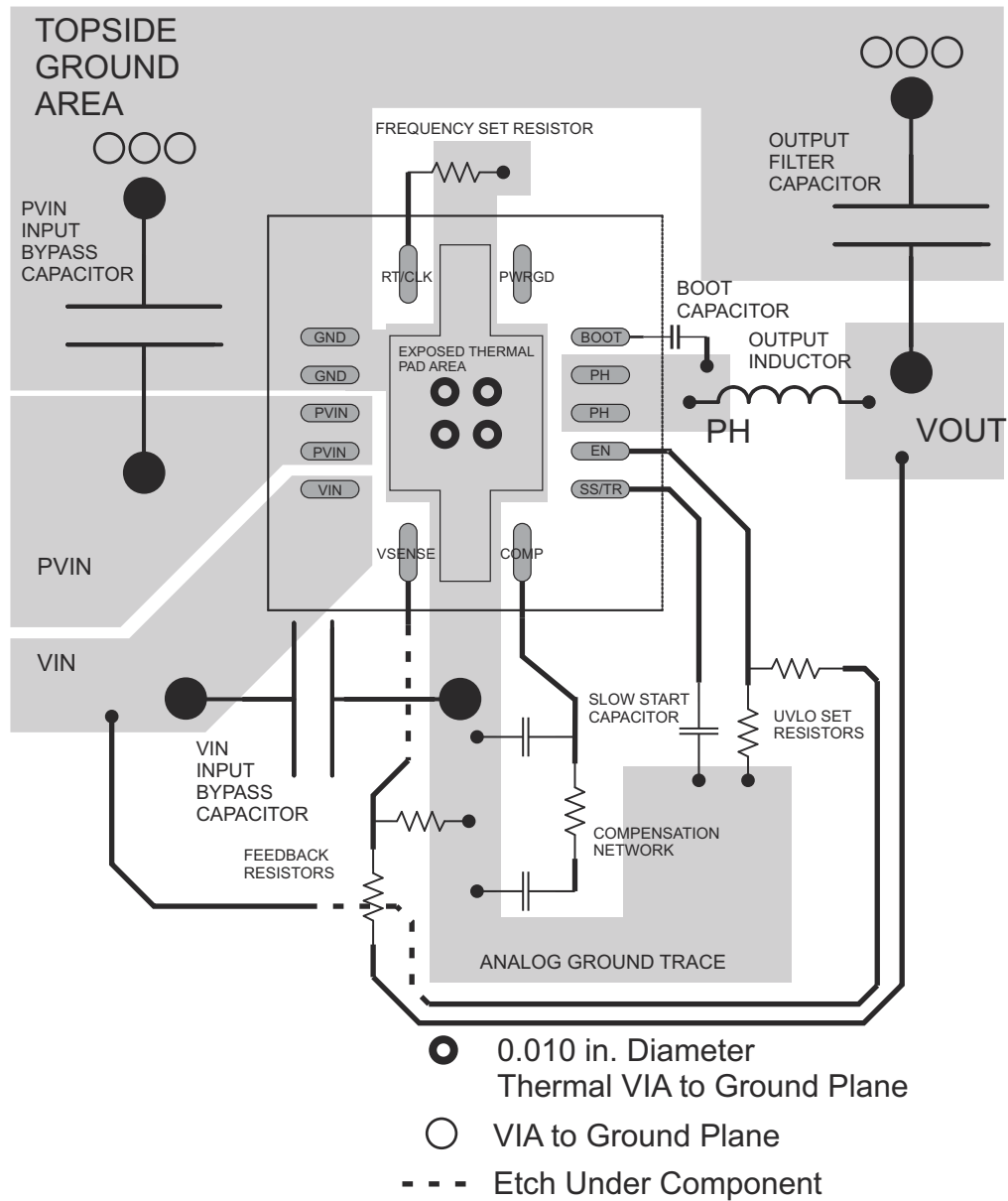

Figure 10-1. PCB Layout

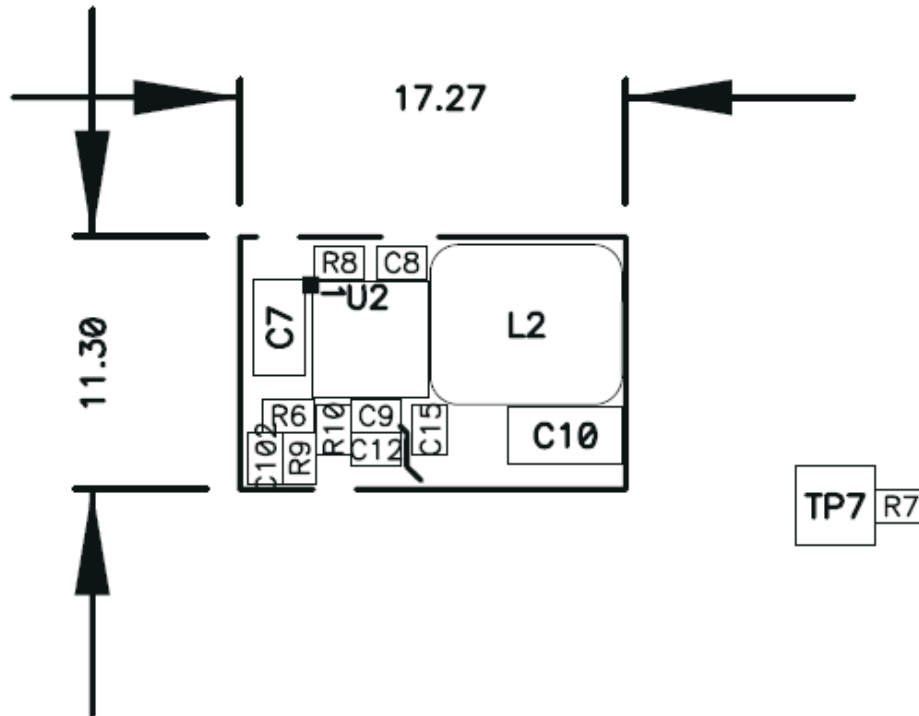

Figure 10-2. Ultra-Small PCB Layout Using TPS54622-EP (PMP4854-2)

10.3 Estimated Circuit Area

The estimated printed-circuit-board area for the components used in the design of [Figure 8-1](#) is 0.58 in² (374 mm²). This area does not include test points or connectors.

11 Device and Documentation Support

11.1 Device Support

11.1.1 Development Support

For the Design Calculator, see [SLVC219](#).

11.1.2 Custom Design With WEBENCH® Tools

[Click here](#) to create a custom design using the TPS54622-EP-EP device with the WEBENCH® Power Designer.

1. Start by entering the input voltage (V_{IN}), output voltage (V_{OUT}), and output current (I_{OUT}) requirements.
2. Optimize the design for key parameters such as efficiency, footprint, and cost using the optimizer dial.
3. Compare the generated design with other possible solutions from Texas Instruments.

The WEBENCH Power Designer provides a customized schematic along with a list of materials with real-time pricing and component availability.

In most cases, these actions are available:

- Run electrical simulations to see important waveforms and circuit performance
- Run thermal simulations to understand board thermal performance
- Export customized schematic and layout into popular CAD formats
- Print PDF reports for the design, and share the design with colleagues

Get more information about WEBENCH tools at www.ti.com/WEBENCH.

11.2 Documentation Support

11.2.1 Related Documentation

For related documentation, see the following:

[Designing Type III Compensation for Current Mode Step-Down Converters](#)

11.3 Receiving Notification of Documentation Updates

To receive notification of documentation updates, navigate to the device product folder on ti.com. Click on *Subscribe to updates* to register and receive a weekly digest of any product information that has changed. For change details, review the revision history included in any revised document.

11.4 Support Resources

[TI E2E™ support forums](#) are an engineer's go-to source for fast, verified answers and design help — straight from the experts. Search existing answers or ask your own question to get the quick design help you need.

Linked content is provided "AS IS" by the respective contributors. They do not constitute TI specifications and do not necessarily reflect TI's views; see TI's [Terms of Use](#).

11.5 Trademarks

TI E2E™ is a trademark of Texas Instruments.

WEBENCH® is a registered trademark of Texas Instruments.

All trademarks are the property of their respective owners.

11.6 Electrostatic Discharge Caution



This integrated circuit can be damaged by ESD. Texas Instruments recommends that all integrated circuits be handled with appropriate precautions. Failure to observe proper handling and installation procedures can cause damage.

ESD damage can range from subtle performance degradation to complete device failure. Precision integrated circuits may be more susceptible to damage because very small parametric changes could cause the device not to meet its published specifications.

11.7 Glossary

[TI Glossary](#) This glossary lists and explains terms, acronyms, and definitions.

12 Mechanical, Packaging, and Orderable Information

The following pages include mechanical, packaging, and orderable information. This information is the most current data available for the designated devices. This data is subject to change without notice and revision of this document. For browser-based versions of this data sheet, refer to the left-hand navigation.

PACKAGING INFORMATION

Orderable part number	Status (1)	Material type (2)	Package Pins	Package qty Carrier	RoHS (3)	Lead finish/ Ball material (4)	MSL rating/ Peak reflow (5)	Op temp (°C)	Part marking (6)
TPS54622RHLREP	Active	Production	VQFN (RHL) 14	3000 LARGE T&R	Yes	NIPDAU	Level-2-260C-1 YEAR	-55 to 125	4622EP
TPS54622RHLREP.A	Active	Production	VQFN (RHL) 14	3000 LARGE T&R	Yes	NIPDAU	Level-2-260C-1 YEAR	-55 to 125	4622EP
V62/20607-01XE	Active	Production	VQFN (RHL) 14	3000 LARGE T&R	Yes	NIPDAU	Level-2-260C-1 YEAR	-55 to 125	4622EP

(1) **Status:** For more details on status, see our [product life cycle](#).

(2) **Material type:** When designated, preproduction parts are prototypes/experimental devices, and are not yet approved or released for full production. Testing and final process, including without limitation quality assurance, reliability performance testing, and/or process qualification, may not yet be complete, and this item is subject to further changes or possible discontinuation. If available for ordering, purchases will be subject to an additional waiver at checkout, and are intended for early internal evaluation purposes only. These items are sold without warranties of any kind.

(3) **RoHS values:** Yes, No, RoHS Exempt. See the [TI RoHS Statement](#) for additional information and value definition.

(4) **Lead finish/Ball material:** Parts may have multiple material finish options. Finish options are separated by a vertical ruled line. Lead finish/Ball material values may wrap to two lines if the finish value exceeds the maximum column width.

(5) **MSL rating/Peak reflow:** The moisture sensitivity level ratings and peak solder (reflow) temperatures. In the event that a part has multiple moisture sensitivity ratings, only the lowest level per JEDEC standards is shown. Refer to the shipping label for the actual reflow temperature that will be used to mount the part to the printed circuit board.

(6) **Part marking:** There may be an additional marking, which relates to the logo, the lot trace code information, or the environmental category of the part.

Multiple part markings will be inside parentheses. Only one part marking contained in parentheses and separated by a "-" will appear on a part. If a line is indented then it is a continuation of the previous line and the two combined represent the entire part marking for that device.

Important Information and Disclaimer: The information provided on this page represents TI's knowledge and belief as of the date that it is provided. TI bases its knowledge and belief on information provided by third parties, and makes no representation or warranty as to the accuracy of such information. Efforts are underway to better integrate information from third parties. TI has taken and continues to take reasonable steps to provide representative and accurate information but may not have conducted destructive testing or chemical analysis on incoming materials and chemicals. TI and TI suppliers consider certain information to be proprietary, and thus CAS numbers and other limited information may not be available for release.

In no event shall TI's liability arising out of such information exceed the total purchase price of the TI part(s) at issue in this document sold by TI to Customer on an annual basis.

OTHER QUALIFIED VERSIONS OF TPS54622-EP :

- Catalog : [TPS54622](#)

NOTE: Qualified Version Definitions:

- Catalog - TI's standard catalog product

TAPE AND REEL INFORMATION



QUADRANT ASSIGNMENTS FOR PIN 1 ORIENTATION IN TAPE



*All dimensions are nominal

Device	Package Type	Package Drawing	Pins	SPQ	Reel Diameter (mm)	Reel Width W1 (mm)	A0 (mm)	B0 (mm)	K0 (mm)	P1 (mm)	W (mm)	Pin1 Quadrant
TPS54622RHLREP	VQFN	RHL	14	3000	330.0	12.4	3.75	3.75	1.15	8.0	12.0	Q2

TAPE AND REEL BOX DIMENSIONS



*All dimensions are nominal

Device	Package Type	Package Drawing	Pins	SPQ	Length (mm)	Width (mm)	Height (mm)
TPS54622RHLREP	VQFN	RHL	14	3000	367.0	367.0	35.0

PACKAGE OUTLINE

RHL0014A

VQFN - 1 mm max height

PLASTIC QUAD FLATPACK - NO LEAD

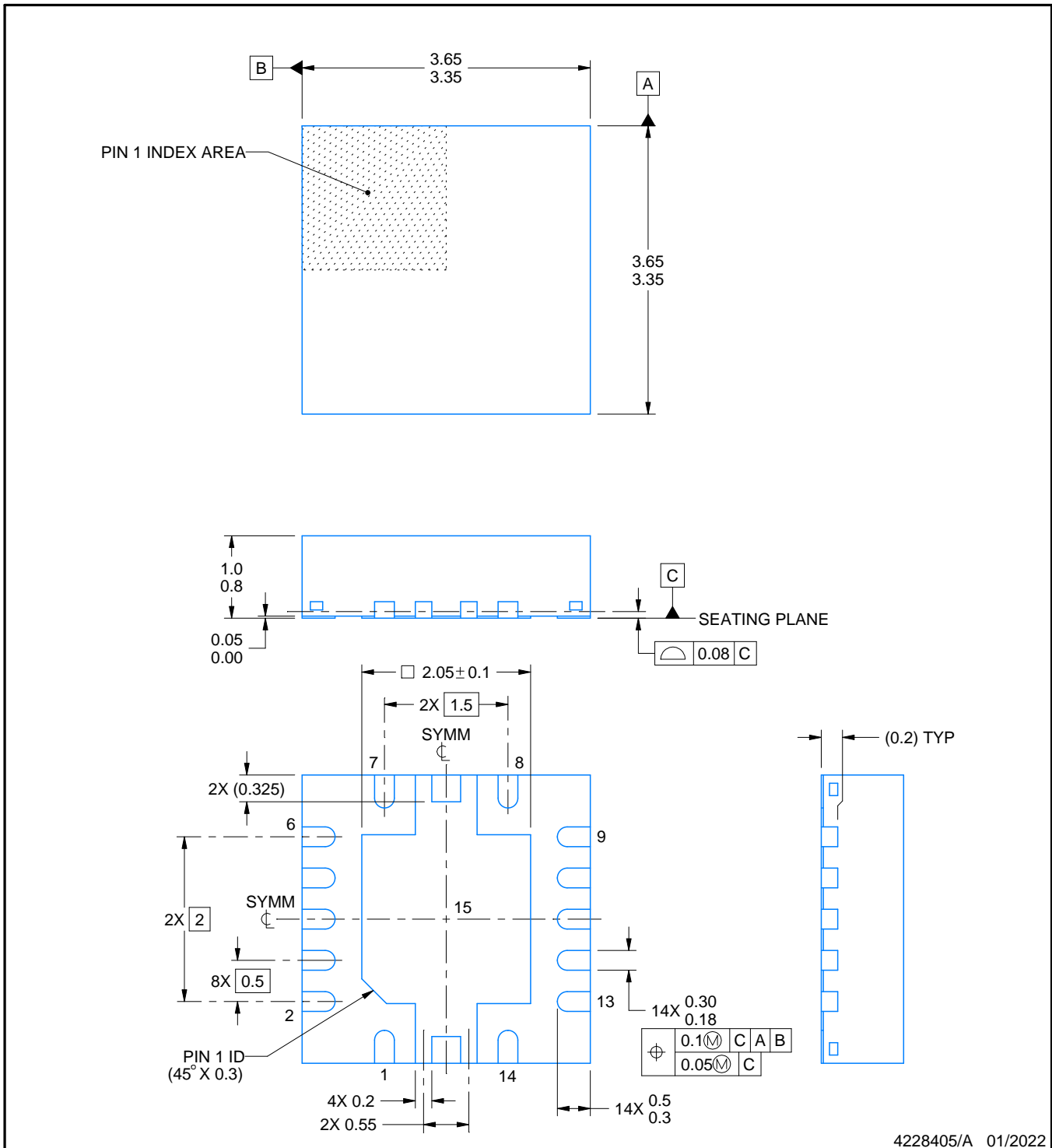

NOTES:

1. All linear dimensions are in millimeters. Any dimensions in parenthesis are for reference only. Dimensioning and tolerancing per ASME Y14.5M.
2. This drawing is subject to change without notice.
3. The package thermal pad must be soldered to the printed circuit board for thermal and mechanical performance.

EXAMPLE BOARD LAYOUT

RHL0014A

VQFN - 1 mm max height

PLASTIC QUAD FLATPACK - NO LEAD

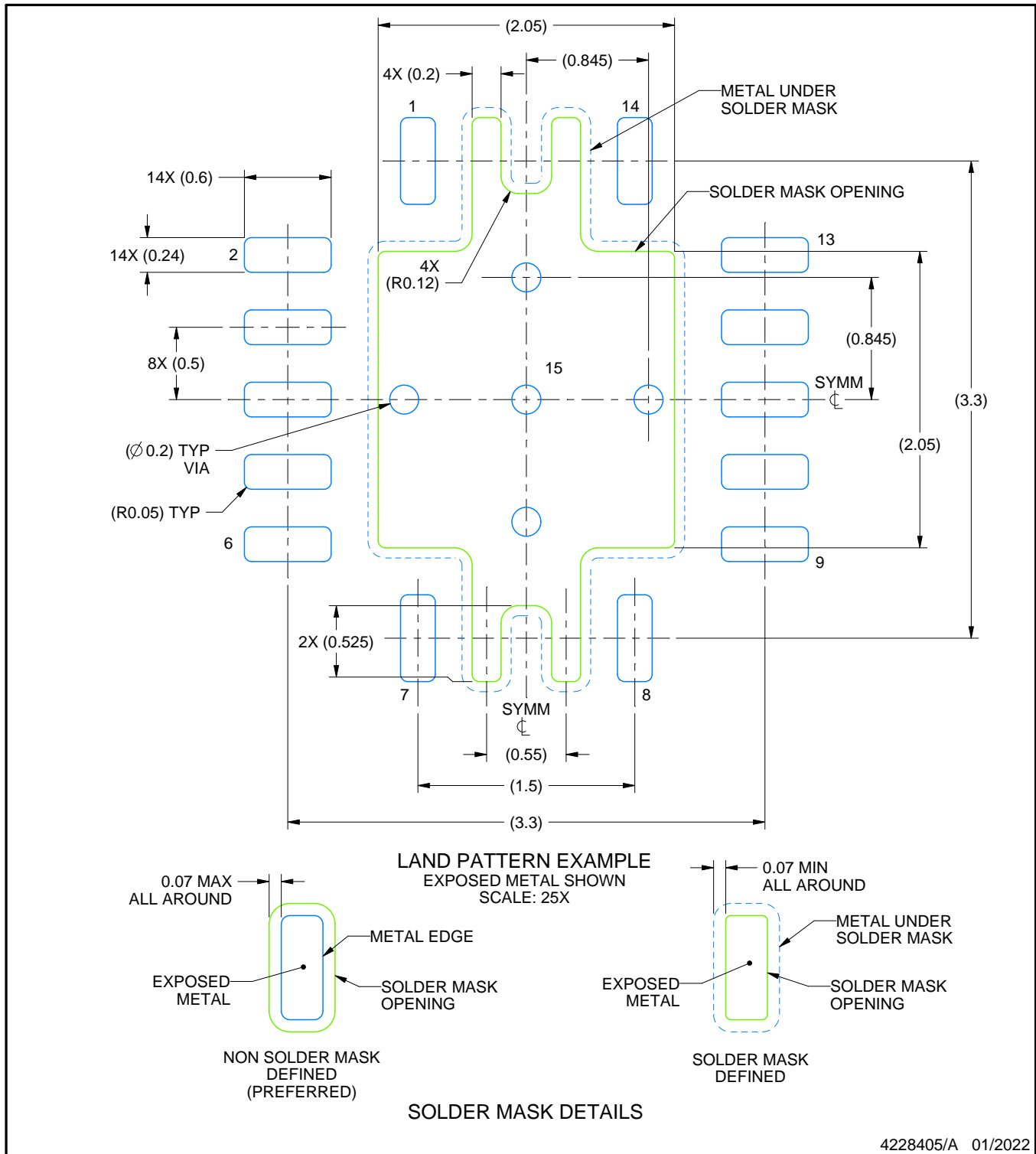

4228405/A 01/2022

NOTES: (continued)

4. This package is designed to be soldered to a thermal pad on the board. For more information, see Texas Instruments literature number SLUA271 (www.ti.com/lit/sluea271).
5. Solder mask tolerances between and around signal pads can vary based on board fabrication site.
6. Vias are optional depending on application, refer to device data sheet. If any vias are implemented, refer to their locations shown on this view. It is recommended that vias under paste be filled, plugged or tented.

EXAMPLE STENCIL DESIGN

RHL0014A

VQFN - 1 mm max height

PLASTIC QUAD FLATPACK - NO LEAD

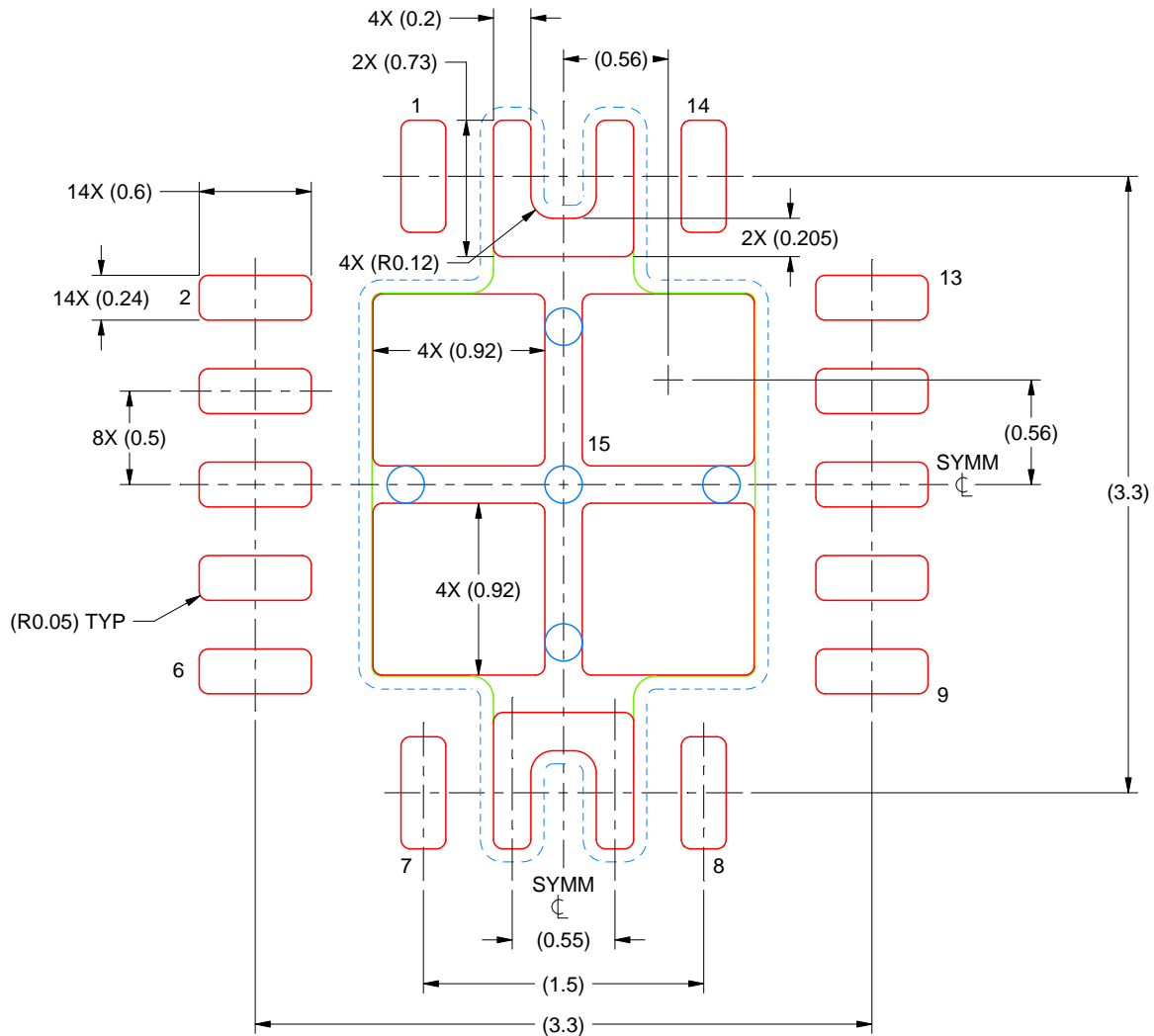

SOLDER PASTE EXAMPLE
 BASED ON 0.125 mm THICK STENCIL

EXPOSED PAD
 79% PRINTED COVERAGE BY AREA
 SCALE: 25X

4228405/A 01/2022

NOTES: (continued)

7. Laser cutting apertures with trapezoidal walls and rounded corners may offer better paste release. IPC-7525 may have alternate design recommendations.

IMPORTANT NOTICE AND DISCLAIMER

TI PROVIDES TECHNICAL AND RELIABILITY DATA (INCLUDING DATASHEETS), DESIGN RESOURCES (INCLUDING REFERENCE DESIGNS), APPLICATION OR OTHER DESIGN ADVICE, WEB TOOLS, SAFETY INFORMATION, AND OTHER RESOURCES "AS IS" AND WITH ALL FAULTS, AND DISCLAIMS ALL WARRANTIES, EXPRESS AND IMPLIED, INCLUDING WITHOUT LIMITATION ANY IMPLIED WARRANTIES OF MERCHANTABILITY, FITNESS FOR A PARTICULAR PURPOSE OR NON-INFRINGEMENT OF THIRD PARTY INTELLECTUAL PROPERTY RIGHTS.

These resources are intended for skilled developers designing with TI products. You are solely responsible for (1) selecting the appropriate TI products for your application, (2) designing, validating and testing your application, and (3) ensuring your application meets applicable standards, and any other safety, security, regulatory or other requirements.

These resources are subject to change without notice. TI grants you permission to use these resources only for development of an application that uses the TI products described in the resource. Other reproduction and display of these resources is prohibited. No license is granted to any other TI intellectual property right or to any third party intellectual property right. TI disclaims responsibility for, and you fully indemnify TI and its representatives against any claims, damages, costs, losses, and liabilities arising out of your use of these resources.

TI's products are provided subject to [TI's Terms of Sale](#), [TI's General Quality Guidelines](#), or other applicable terms available either on [ti.com](#) or provided in conjunction with such TI products. TI's provision of these resources does not expand or otherwise alter TI's applicable warranties or warranty disclaimers for TI products. Unless TI explicitly designates a product as custom or customer-specified, TI products are standard, catalog, general purpose devices.

TI objects to and rejects any additional or different terms you may propose.

Copyright © 2025, Texas Instruments Incorporated

Last updated 10/2025