

# TUSB212-Q1 USB 2.0高速信号コンディショナー

## 1 特長

- 車載アプリケーション用に認定済み
  - デバイス温度グレード 2: 動作時周囲温度 -40°C~105°C
  - デバイスHBM分類レベルH1C
  - デバイスCDM分類レベルC3
- USB 2.0、OTG 2.0、BC 1.2と互換
- ピン・ストラップまたはI<sup>2</sup>Cで構成可能
- LS、FS、HS信号処理のサポート
- USB切断およびシャットダウン時の非常に低い消費電力
- 損失の大きなアプリケーション用に、デジター・チェーン・デバイスにより信号ゲインを選択可能
- D1P/MおよびD2P/Mを交換可能で、ホスト/デバイスに非依存
- プリチャネルで最大5m、ポストチャネルで最大2mの長さのケーブルに対応
  - 外付けのプルダウン抵抗により、4つのAC昇圧設定を選択可能
  - DC昇圧とAC昇圧により最良の信号整合性を実現

## 2 アプリケーション

- 車載インフォテインメント
- ノートブックPC
- デスクトップ
- ドッキング・ステーション
- タブレット
- 携帯電話
- アクティブ・ケーブル、ケーブル・エクステンダ
- バックプレーン
- TV

## 3 概要

TUSB212-Q1は、USBハイ・スピード(HS)信号コンディショナーで、伝送チャネルでのISI信号損失を補償するよう設計されています。

TUSB212-Q1は、特許出願中の設計により、USBロー・スピード(LS)およびフル・スピード(FS)信号でも関係なく動作します。LSおよびFS信号の特性は、TUSB212-Q1により影響を受けず、HS信号は補償されます。

信号のAC昇圧およびDC昇圧をプログラム可能であり、コネクタでハイ・スピード信号を最適化するようデバイスの性能を微調整できます。この機能は、USBハイ・スピード電気コンプライアンス・テストに合格するため役立ちます。

さらに、TUSB212-Q1はUSB On-The-Go (OTG)やBattery Charging (BC)プロトコルとも互換性があります。

### 製品情報 (1)

型番	パッケージ	本体サイズ(公称)
TUSB212-Q1	X2QFN (12)	1.60mmx1.60mm

(1) 利用可能なすべてのパッケージについては、このデータシートの末尾にある注文情報を参照してください。

概略回路図

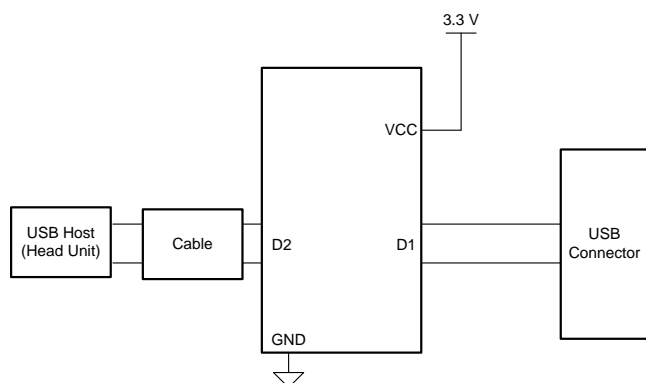

Copyright © 2017, Texas Instruments Incorporated

ディスプレイ



Copyright © 2017, Texas Instruments Incorporated



## 目次

<b>1</b>	<b>特長</b> .....	<b>1</b>	7.4	Device Functional Modes.....	<b>9</b>
<b>2</b>	<b>アプリケーション</b> .....	<b>1</b>	<b>8</b>	<b>Application and Implementation</b> .....	<b>10</b>
<b>3</b>	<b>概要</b> .....	<b>1</b>	8.1	Application Information.....	<b>10</b>
<b>4</b>	<b>改訂履歴</b> .....	<b>2</b>	8.2	Typical Application.....	<b>10</b>
<b>5</b>	<b>Pin Configuration and Functions</b> .....	<b>3</b>	<b>9</b>	<b>Power Supply Recommendations</b> .....	<b>17</b>
<b>6</b>	<b>Specifications</b> .....	<b>4</b>	<b>10</b>	<b>Layout</b> .....	<b>18</b>
6.1	Absolute Maximum Ratings.....	<b>4</b>	10.1	Layout Guidelines.....	<b>18</b>
6.2	ESD Ratings.....	<b>4</b>	10.2	Layout Example.....	<b>18</b>
6.3	Recommended Operating Conditions.....	<b>4</b>	<b>11</b>	<b>デバイスおよびドキュメントのサポート</b> .....	<b>19</b>
6.4	Thermal Information.....	<b>4</b>	11.1	ドキュメントのサポート.....	<b>19</b>
6.5	Electrical Characteristics.....	<b>5</b>	11.2	ドキュメントの更新通知を受け取る方法.....	<b>19</b>
6.6	Switching Characteristics.....	<b>6</b>	11.3	コミュニティ・リソース.....	<b>19</b>
6.7	Typical Characteristics.....	<b>7</b>	11.4	商標.....	<b>19</b>
<b>7</b>	<b>Detailed Description</b> .....	<b>8</b>	11.5	静電気放電に関する注意事項.....	<b>19</b>
7.1	Overview.....	<b>8</b>	11.6	Glossary.....	<b>19</b>
7.2	Functional Block Diagram.....	<b>8</b>	<b>12</b>	<b>メカニカル、パッケージ、および注文情報</b> .....	<b>19</b>
7.3	Feature Description.....	<b>8</b>			

## 4 改訂履歴

日付	改訂内容	注
2017年8月	*	初版

## 5 Pin Configuration and Functions

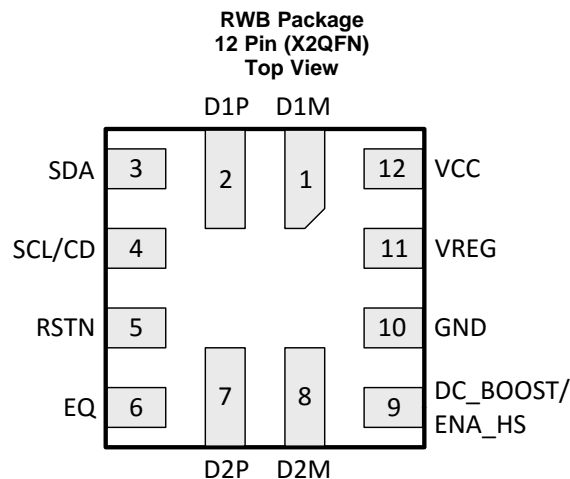

### Pin Functions

PIN		I/O	INTERNAL PULLUP/PULLDOWN	DESCRIPTION
NAME	NO.			
D1M	1	I/O	N/A	USB High Speed negative port..
D1P	2	I/O	N/A	USB High Speed positive port.
SDA <sup>(1)</sup>	3	I/O	RSTN asserted: 500 kΩ PD	I2C Mode: Bidirectional I2C data pin [I2C address = 0x2C]. In non I2C mode: Reserved for TI test purpose.
SCL <sup>(1)</sup> /CD	4	I/O	RSTN asserted: 500 kΩ PD	In I2C mode: I2C clock pin [I2C address = 0x2C]. Non I2C mode: After reset: Output CD. Flag indicating that a USB device is attached (connection detected). Asserted from an unconnected state upon detection of DP or DM pull-up resistor. De-asserted upon detection of disconnect.
RSTN	5	I	500 kΩ PU	Device disable/enable. Low – Device is at reset and in shutdown, and High – Normal operation. Recommend 0.1-μF external capacitor to GND to ensure clean power on reset if not driven. If the pin is driven, it must be held low until the supply voltage for the device reaches within specifications.
EQ	6	I	N/A	USB High Speed AC boost select via external pull down resistor. Sampled upon de-assertion of RSTN. Does not recognize real time adjustments. Auto selects max AC Boost when left floating.
D2P	7	I/O	N/A	USB High Speed positive port.
D2M	8	I/O	N/A	USB High Speed negative port.
DC_BOOST <sup>(2)</sup> / ENA_HS	9	I/O		In I2C mode: Reserved for TI test purpose. In non-I2C mode: At reset: 3-level input signal DC_BOOST. USB High Speed DC signal boost selection. H (pin is pulled high) – 80 mV M (pin is left floating) – 60 mV L (pin is pulled low) – 40 mV After reset: Output signal ENA_HS. Flag indicating that channel is in High Speed mode. Asserted upon: 1. Detection of USB-IF High Speed test fixture from an unconnected state followed by transmission of USB TEST_PACKET pattern. 2. Squelch detection following USB reset with a successful HS handshake [HS handshake is declared to be successful after single chirp J chirp K pair where each chirp is within 18 μs – 128 μs].
GND	10	P	N/A	Ground
VREG	11	O	N/A	1.8-V LDO output. Only enabled when operating in High Speed mode. Requires 0.1-μF external capacitor to GND to stabilize the core.
VCC	12	P	N/A	Supply power

- (1) Pull-up resistors for SDA and SCL pins in I<sup>2</sup>C mode should be 2 kΩ (5%). If both SDA and SCL are pulled up at reset the device enters into I<sup>2</sup>C mode.
- (2) Pull-down and pull-up (to 3.3 V) resistors for DC\_BOOST pins must be between 22 kΩ to 47 kΩ in non I<sup>2</sup>C mode.

## 6 Specifications

### 6.1 Absolute Maximum Ratings

over operating free-air temperature range (unless otherwise noted)<sup>(1)</sup>

		MIN	MAX	UNIT
Supply Voltage Range	VCC	-0.3	3.8	V
Voltage Range on I/O pins	DxP, DxM, RSTN, EQ, SCL, SDA, DC_BOOST, VREG	-0.3	3.8	V
T <sub>stg</sub>	Storage temperature	-65	150	°C

- (1) Stresses beyond those listed under *Absolute Maximum Rating* may cause permanent damage to the device. These are stress ratings only, which do not imply functional operation of the device at these or any other conditions beyond those indicated under *Recommended Operating Condition*. Exposure to absolute-maximum-rated conditions for extended periods may affect device reliability.

### 6.2 ESD Ratings

			VALUE	UNIT
V <sub>(ESD)</sub>	Electrostatic discharge	Human body model (HBM), per ANSI/ESDA/JEDEC JS-001, all pins <sup>(1)</sup>	±2000	V
		Charged device model (CDM), per JEDEC specification JESD22-C101, all pins <sup>(2)</sup>	±500	

- (1) JEDEC document JEP155 states that 500-V HBM allows safe manufacturing with a standard ESD control process.

- (2) JEDEC document JEP157 states that 250-V CDM allows safe manufacturing with a standard ESD control process.

### 6.3 Recommended Operating Conditions

over operating free-air temperature range (unless otherwise noted)

		MIN	NOM	MAX	UNIT
V <sub>CC</sub>	Supply voltage	3	3.3	3.6	V
T <sub>A</sub>	Ambient temperature	TUSB212Q1		105	°C
T <sub>J</sub>	Junction temperature	TUSB212Q1		105	°C

### 6.4 Thermal Information

THERMAL METRIC <sup>(1)</sup>		RWB (VQFN)	UNIT
		12 PINS	
R <sub>θJA</sub>	Junction-to-ambient thermal resistance	137.4	°C/W
R <sub>θJC(top)</sub>	Junction-to-case (top) thermal resistance	62	°C/W
R <sub>θJB</sub>	Junction-to-board thermal resistance	67.2	°C/W
Ψ <sub>JT</sub>	Junction-to-top characterization parameter	1.9	°C/W
Ψ <sub>JB</sub>	Junction-to-board characterization parameter	67.3	°C/W
R <sub>θJC(bot)</sub>	Junction-to-case (bottom) thermal resistance	N/A	°C/W

- (1) For more information about traditional and new thermal metrics, see the [Semiconductor and IC Package Thermal Metrics](#) application report.

## 6.5 Electrical Characteristics

over operating free-air temperature range (unless otherwise noted)

PARAMETER		TEST CONDITIONS	MIN	TYP	MAX	UNIT
<b>POWER</b>						
$I_{ACTIVE\_HS}$	High-speed active current	USB channel = HS mode; 480 Mbps traffic; $V_{CC} = 3.3V$ ; $V_{CC}$ supply stable; DC Boost = 60 mV		22	30	mA
$I_{IDLE\_HS}$	High-speed idle current	USB channel = HS mode; no traffic; $V_{CC} = 3.3V$ ; $V_{CC}$ supply stable; DC Boost = 60 mV		14	22	mA
$I_{SUSPEND\_HS}$	High-speed suspend current	USB channel = HS suspend mode; $V_{CC} = 3.3V$ ; $V_{CC}$ supply stable		0.55	1.5	mA
$I_{FS\_LS}$	Full/Low speed current	USB channel = FS mode or LS mode; $V_{CC} = 3.3V$		0.6	1.5	mA
$I_{DISCONNECT}$	Disconnect current	Host side application; No device attachment; $V_{CC} = 3.3V$		0.7	1.5	mA
$I_{RSTN}$	Disable current	RSTN driven low; $V_{CC}$ supply stable; $V_{CC} = 3.3V$		13	80	$\mu A$
$I_{LKG\_FS}$	Pin fail-safe leakage current for SDA, SCL, DC_BOOST, DxP/N, RSTN	$V_{CC} = 0 V$ ; Pin at 3.6 V			40	$\mu A$
<b>RSTN</b>						
$V_{IH}$	High-level input voltage		2		3.6	V
$V_{IL}$	Low-level input voltage		0		0.8	V
$I_{IH}$	High-level input current	$V_{IH} = 3.6 V$	-4		4	$\mu A$
$I_{IL}$	Low-level input current	$V_{IL} = 0 V$	-11		11	$\mu A$
<b>EQ</b>						
$R_{EQ}$	External pull-down resistor on EQ pin.	AC Boost Level 0			160	$\Omega$
		AC Boost Level 1	1.4		2	k $\Omega$
		AC Boost Level 2	3.7		3.9	k $\Omega$
		AC Boost Level 3	6			k $\Omega$
<b>CD, ENA_HS</b>						
$V_{OH}$	High-level output voltage	$I_O = -50\mu A$	2.4			V
$V_{OL}$	Low-level output voltage	$I_O = 50\mu A$			0.4	V
<b>SCL, SDA</b>						
$C_{I2CBUS}$	I2C Bus capacitance		4		150	pF
<b>DC_BOOST</b>						
$V_{IH}$	High-level input voltage		2.4		3.6	V
$V_{IM}$	Mid-level input voltage			1.6		V
$V_{IL}$	Low-level input voltage		0		0.4	V
<b>DxP, DxM</b>						
$C_{IO\_DXX}$	Capacitance to GND	Measured with LCR meter and device powered down. 1 MHz sinusoid, 30 mVpp ripple		2.4		pF

## 6.6 Switching Characteristics

over operating free-air temperature range (unless otherwise noted)

PARAMETER		TEST CONDITIONS	MIN	TYP	MAX	UNIT
$F_{BR\_DXX}$	DxP/M Bit Rate	USB channel = HS mode; 480 Mbps traffic; VCC supply stable			480.24	Mbps
$t_{RISE\_DXX}$	DxP/M rise time		100			ps
$t_{FALL\_DXX}$	DxP/M fall time		100			ps
$t_{RSTN\_PU}$ $LSE\_WIDT$ H	Minimum width to detect a valid RSTN signal assert when the pin is actively driven	$V_{CC} = 3.0\text{ V}$ ; Refer to <a href="#">Fig 1</a>	20			$\mu\text{s}$
$t_{STABLE}$	VCC stable before RSTN de-assertion	Refer to <a href="#">Fig 1</a>	100			$\mu\text{s}$
$t_{VCC\_RAM}$ P	VCC ramp time		0.2		100	ms

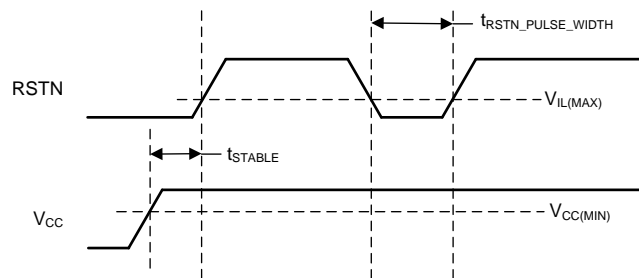

**Fig 1. Power On and Reset Timing**

## 6.7 Typical Characteristics



图 2. USB2.0 HS Eye Diagram, Host far-end with 2m cable post-channel loss without TUSB212-Q1



图 3. USB 2.0 HS Eye Diagram, Host far-end with 2m cable post-channel loss with TUSB212-Q1

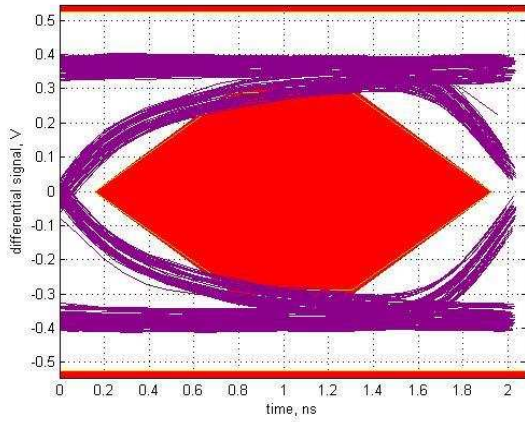

图 4. USB2.0 HS Eye Diagram, Host far-end with 5m cable pre-channel loss without TUSB212-Q1

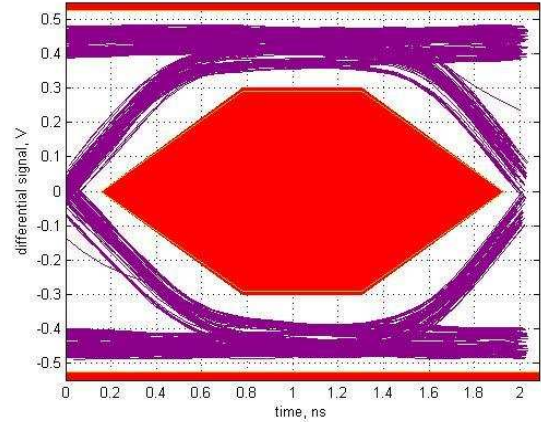

图 5. USB2.0 HS Eye Diagram, Host far-end with 5m cable pre-channel loss with TUSB212-Q1

## 7 Detailed Description

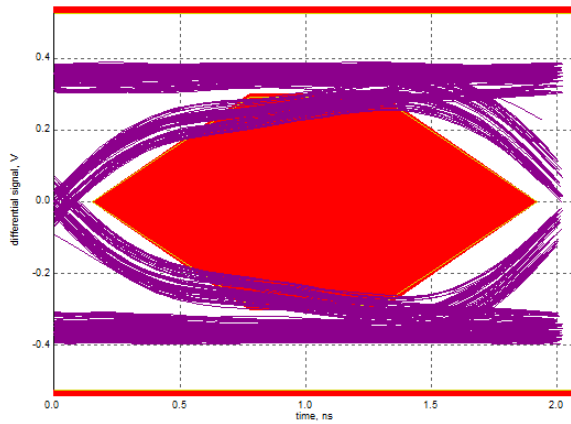
### 7.1 Overview

The TUSB212-Q1 is a USB High-Speed (HS) signal conditioner, designed to compensate for ISI signal loss in a transmission channel. TUSB212-Q1 has a patent-pending design which is agnostic to USB Low Speed (LS) and Full Speed (FS) signals and does not alter their signal characteristics, while HS signals are compensated. In addition, the design is compatible with USB On-The-Go (OTG) and Battery Charging (BC) specifications.

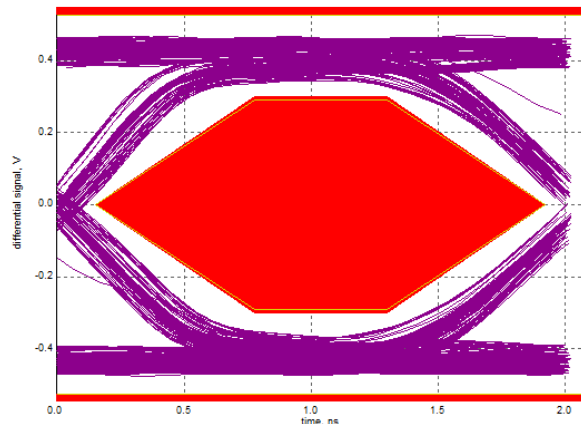
Programmable signal gain through an external resistor permits fine tuning device performance to optimize signals helping to pass USB HS electrical compliance tests at the connector. Additional DC boost configurable by three level input DC\_BOOST helps overcoming the cable losses.

The footprint of TUSB212-Q1 allows a board layout using this device such that it does not break the continuity of the DP/DM signal traces. This permits risk free system design of a complete USB channel with flexible use of one or multiple TUSB212-Q1 devices as needed for optimal signal integrity. This allows system designers to plan for this device and use it only if signal integrity analysis and/or lab measurements show a need. If such a need is not warranted, the device can be left unpopulated without any board rework.

### 7.2 Functional Block Diagram

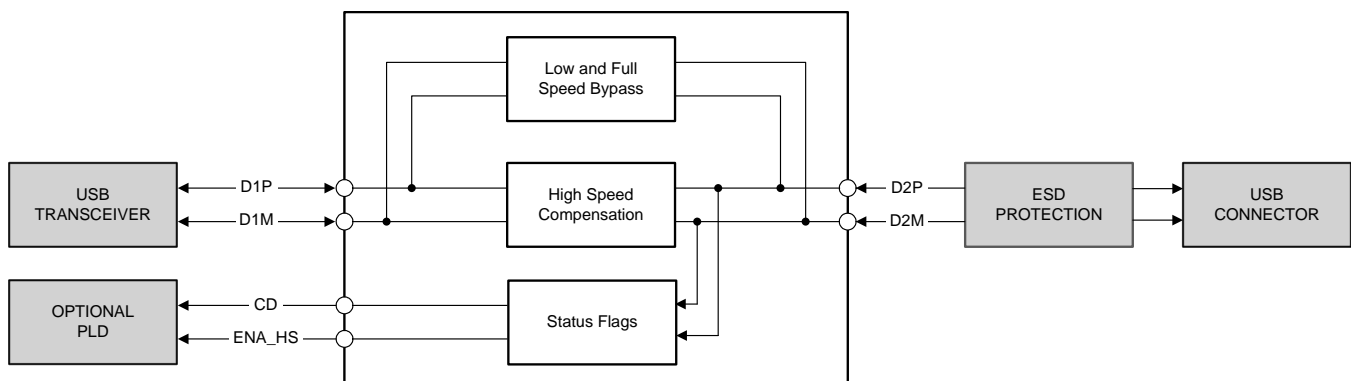

### 7.3 Feature Description

#### 7.3.1 EQ

The EQ pin of the TUSB212-Q1 is used to configure the AC boost of the device. The four levels are set through different values of an external pulldown resistor at this pin.

#### 7.3.2 DC BOOST

The DC\_BOOST pin of the TUSB212-Q1 is a tri-level pin, used to set the DC gain of the device according to [表 1](#).

**表 1. DC Boost Settings**

DC BOOST SETTING VIA PIN STRAP	
DC_BOOST	DC Boost Setting (mV)
$V_{IL}$	40
$V_{IM}$	60
$V_{IH}$	80



## 7.4 Device Functional Modes

### 7.4.1 Low Speed (LS) Mode

TUSB212-Q1 automatically detects a LS connection and does not enable signal compensation. CD pin is asserted high.

### 7.4.2 Full Speed (FS) Mode

TUSB212-Q1 automatically detects a FS connection and does not enable signal compensation. CD pin is asserted high.

### 7.4.3 High Speed (HS) Mode

TUSB212-Q1 automatically detects a HS connection and will enable signal compensation as determined by the configuration of the DC\_BOOST pin and the external pulldown resistance on its EQ pin. CD pin is asserted high.

### 7.4.4 Shutdown Mode

TUSB212-Q1 is disabled when its RSTN pin is asserted low. In shutdown mode the USB channel is still fully operational, but there is neither signal compensation nor any indication from the CD pin as to the status of the channel.

### 7.4.5 I<sup>2</sup>C Mode

TUSB212-Q1 supports 100 kHz I<sup>2</sup>C for device configuration, status readback and test purposes. This controller is enabled after SCL and SDA pins are sampled high shortly after de-assertion of RSTN. In this mode, the register as described in 表 2 can be accessed by I<sup>2</sup>C read/write transaction to 7-bit slave address 0x2C. It is necessary to set CFG\_ACTIVE bit and reset it to zero after making changes to the EQ and DC Boost level registers to restart the state machine.

#### 注

All registers or fields in 表 2 which are not specifically mentioned are considered reserved. The default value of these reserved registers or fields must not be changed. It is suggested to perform a read-modify-write operation to maintain the default value of the reserved fields.

**表 2. Register definition**

Offset	Bit(s)	Name	Type	Default	Description
0x01	6:4	ACB_LVL	RW	XXX (Sampled from EQ pin at reset)	Sets the level of AC Boost 000 : Level 0 AC Boost programmed [MIN] 001 : Level 1 AC Boost programmed 011 : Level 2 AC Boost programmed 111 : Level 3 AC Boost programmed [MAX]
0x03	0	CFG_ACTIVE	RW	1b	Configuration mode 0 : Normal mode. State machine enabled. 1 : Configuration mode: State machine disabled. After reset, if I2C mode is true (SCL and SDA are both pulled high) it is maintained until it is cleared by an I2C write, but, if I2C mode is not true, it is cleared automatically.
0x0E	2:0	DCB_LVL	RW	XXX (Sampled from DC_BOOST pin at reset)	Sets the level of DC Boost 011 : 40mV (DC_Boost = L) 101 : 60mV (DC_Boost = M, default) 111 : 80mV (DC_Boost = H)

## 8 Application and Implementation

### 注

Information in the following applications sections is not part of the TI component specification, and TI does not warrant its accuracy or completeness. TI's customers are responsible for determining suitability of components for their purposes. Customers should validate and test their design implementation to confirm system functionality.

### 8.1 Application Information

The primary purpose of the TUSB212-Q1 is to re-store the signal integrity of a USB High Speed channel up to the USB receptacle. The loss in signal quality stems from reduced channel bandwidth due to high loss PCB trace and other components that contribute a capacitive load. This can cause the channel to fail the USB near end eye mask. Proper use of the TUSB212-Q1 can help to pass this eye mask.

A secondary purpose is to use the CD pin of the TUSB212-Q1 to control other blocks on the customer platform if so desired.

### 8.2 Typical Application

A typical application is shown in [Figure 6](#). In this setup, D2P and D2M face the USB connector while D1P and D1M face the USB host. If desired, the orientation may be reversed [that is, D2 faces transceiver and D1 faces connector].

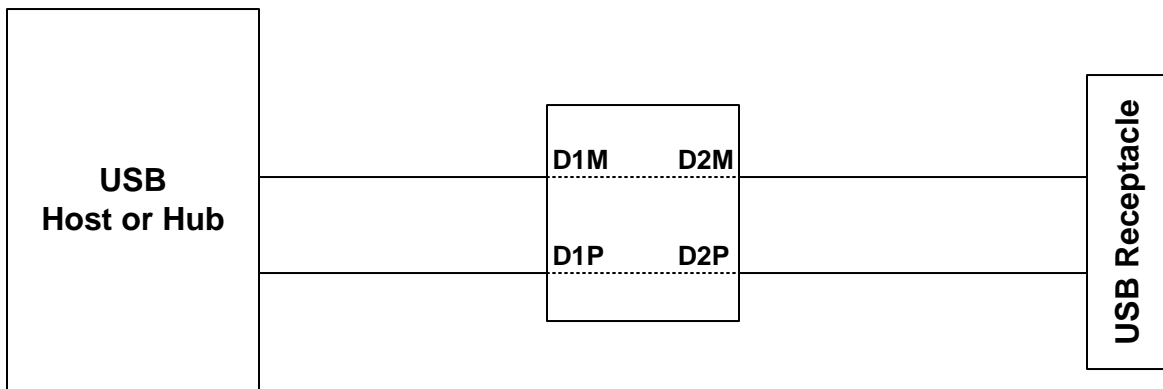

Copyright © 2017, Texas Instruments Incorporated

**图 6. Typical Application**

#### 8.2.1 Design Requirements

For this design example, use parameters shown in the table below.

**表 3. Design Parameters**

PARAMETER		VALUE
VCC (3.0V to 3.6V)		3.3V
I <sup>2</sup> C support required in system (Yes/No)		No
AC Boost	R <sub>EQ</sub>	Level
	0-ohms	0
	1.69k +/- 1%	1
	3.83k +/- 1%	2
	DNI	3
		AC Boost Level 2: R <sub>EQ</sub> = 3.83K

**Typical Application (continued)**
**表 3. Design Parameters (continued)**

PARAMETER				VALUE
DC Boost	R <sub>DC1</sub>	R <sub>DC2</sub>	Level	Mid DC Level: R <sub>DC1</sub> = DNI R <sub>DC2</sub> = DNI
	22k - 47k ohms	Do Not Install (DNI)	40mV Low DC Boost	
	DNI	DNI	60mV Mid DC Boost	
	DNI	22k - 47k ohms	80mV High DC Boost	

**8.2.2 Detailed Design Procedure**

TUSB212-Q1 requires a valid reset signal as described in the power supply recommendations section. The capacitor at RSTN pin is not required if a microcontroller drives the RSTN pin according to recommendations.

VREG pin is the internal LDO output that requires a 0.1- $\mu$ F external capacitor to GND to stabilize the core.

The ideal AC/DC Boost setting is dependent upon the signal chain loss characteristics of the target platform. The general recommendation is to start with AC Boost level 0, and then increment to AC Boost level 1, etc. when needed. Same applies to the DC boost setting where it is recommended to plan for the required pad to change boost settings.

In order for the TUSB212-Q1 to recognize any change to the AC or DC boost settings, the RSTN pin must be toggled. This is because the EQ and DC\_BOOST pins are latched on power up and the pins are ignored thereafter.

Further D1P has to be shorted to D2P and D1M shorted to D2M on the board for correct functionality of the device.

Placement of the device is also dependent on the application goal. [表 4](#) summarizes our recommendations.

**表 4. Platform Placement Guideline**

PLATFORM GOAL	SUGGESTED TUSB212-Q1 PLACEMENT
Pass USB Near End Mask	Close to measurement point
Pass USB Far End Eye Mask	Close to USB PHY
Cascade multiple TUSB212-Q1 to improve device enumeration	Midway between each USB interconnect

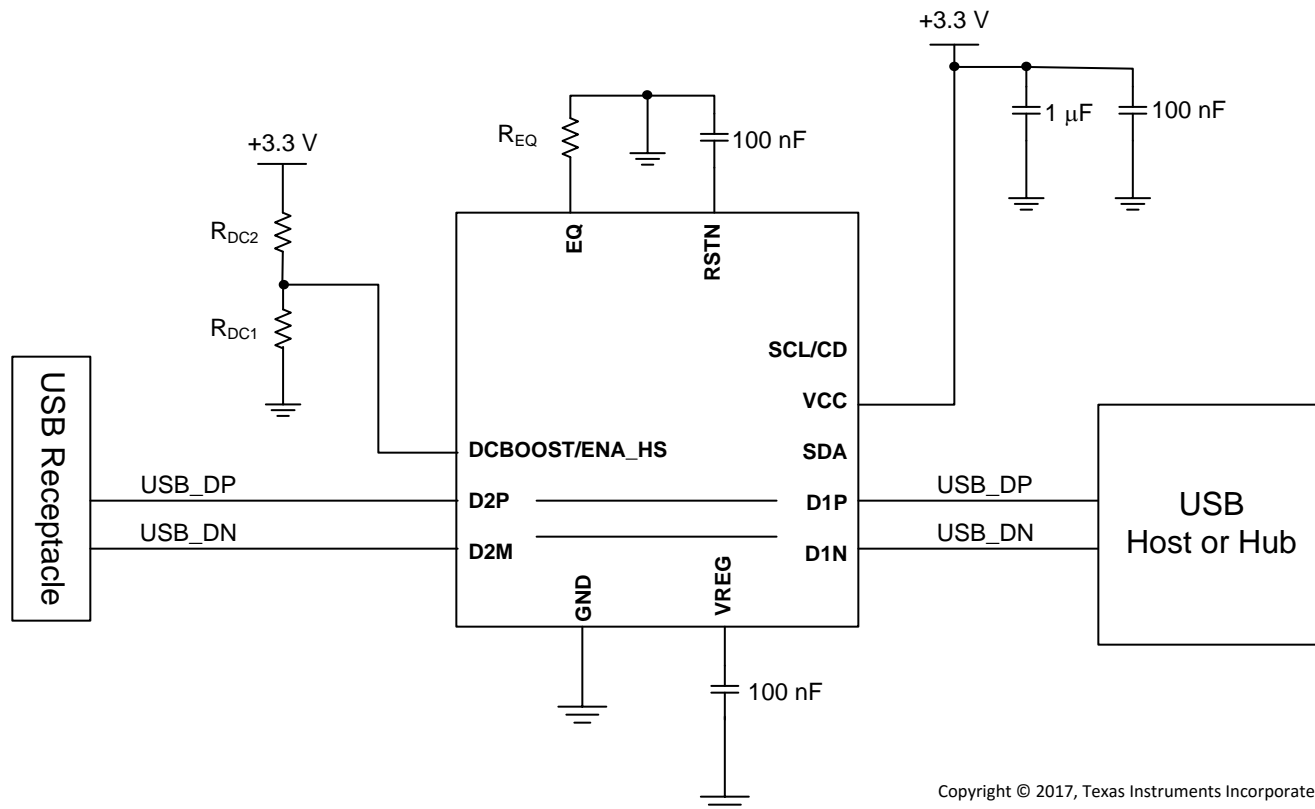

Copyright © 2017, Texas Instruments Incorporated

D2P must be shorted to D1P on PCB.

D2N must be shorted to D1N on PCB.

**图 7. Reference Schematic**

### 8.2.2.1 Test Procedure to Construct USB High Speed Eye Diagram

注

USB-IF certification tests for High Speed eye masks require the *mandated use* of the USB-IF developed test fixtures. These test fixtures do not require the use of oscilloscope probes. Instead they use SMA cables. More information can be found at the USB-IF Compliance Updates Page. It is located under the 'Electricals' section, ID 86 dated March 2013.

The following procedure must be followed before using any oscilloscope compliance software to construct a USB High Speed Eye Mask:

#### 8.2.2.1.1 For a Host Side Application

1. Configure the TUSB212-Q1 to the desired AC and DC boost settings.
2. Power on (or toggle the RSTN pin if already powered on) the TUSB212-Q1
3. Using SMA cables, connect the oscilloscope and the USB-IF host-side test fixture to the TUSB212-Q1
4. Enable the host to transmit USB TEST\_PACKET
5. Execute the oscilloscope USB compliance software.
6. Repeat the above steps in order to re-test TUSB212-Q1 with different AC and DC boost settings.

#### 8.2.2.1.2 For a Device Side Application

1. Configure the TUSB212-Q1 to the desired AC and DC boost settings.
2. Power on (or toggle the RSTN pin if already powered on) the TUSB212-Q1

3. Connect a USB host, the USB-IF device-side test fixture, and USB device to the TUSB212-Q1. Ensure that the USB-IF device test fixture is configured to the 'INIT' position
4. Allow the host to enumerate the device
5. Enable the device to transmit USB TEST\_PACKET
6. Using SMA cables, connect the oscilloscope to the USB-IF device-side test fixture and ensure that the device-side test fixture is configured to the 'TEST' position.
7. Execute the oscilloscope USB compliance software.
8. Repeat the above steps in order to re-test TUSB212-Q1 with different AC and DC boost settings.

**8.2.3 Application Curves**

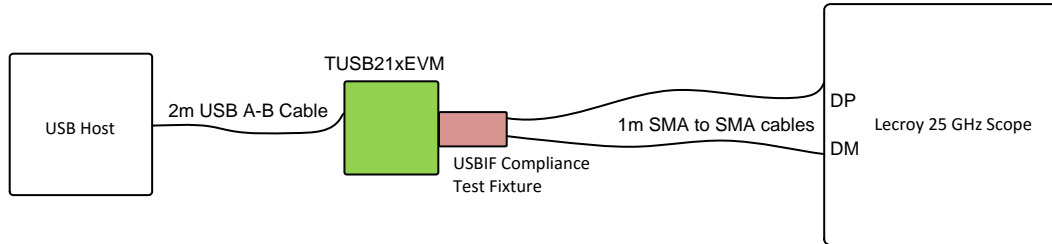

**8. Eye Diagram Bench Setup**

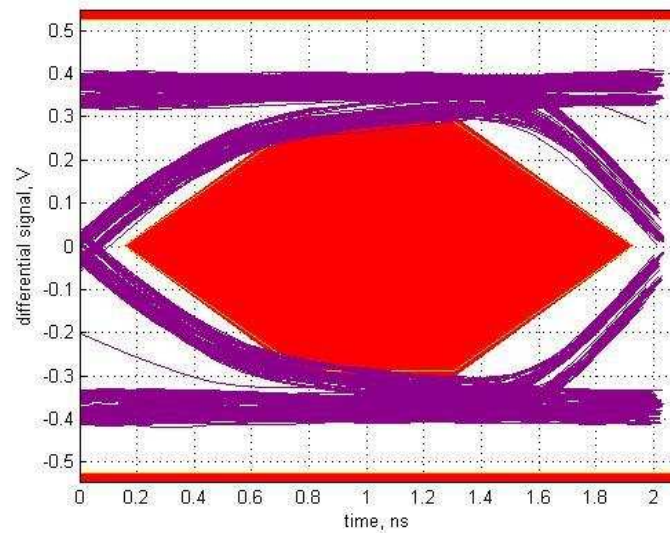

**9. No TUSB212-Q1**

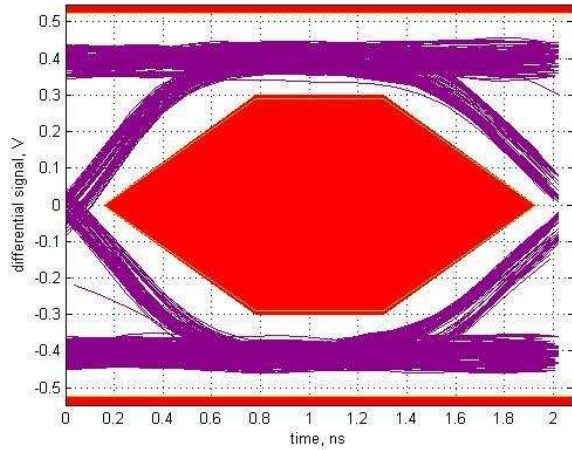

⊠ 10. Low DC Boost, AC Boost Level 0

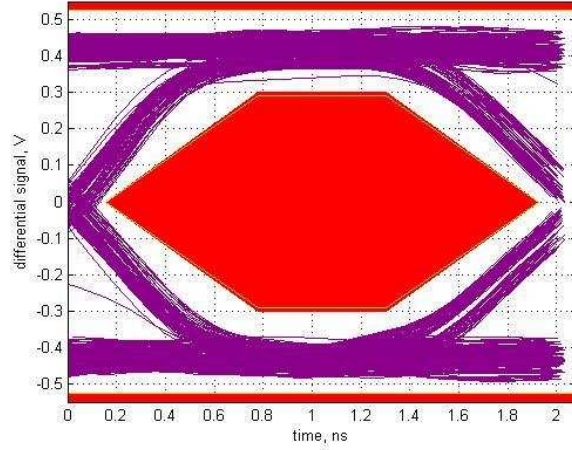

⊠ 11. Mid DC Boost, AC Boost Level 0

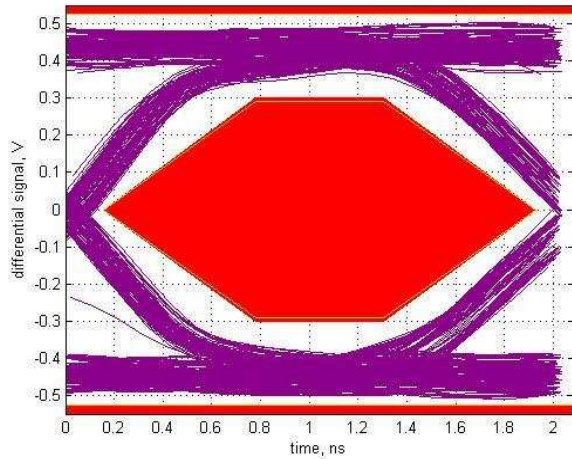

⊠ 12. High DC Boost, AC Boost Level 0

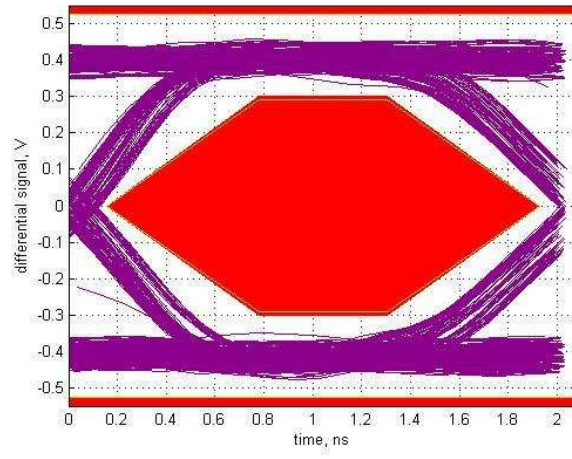

⊠ 13. Low DC Boost, AC Boost Level 1

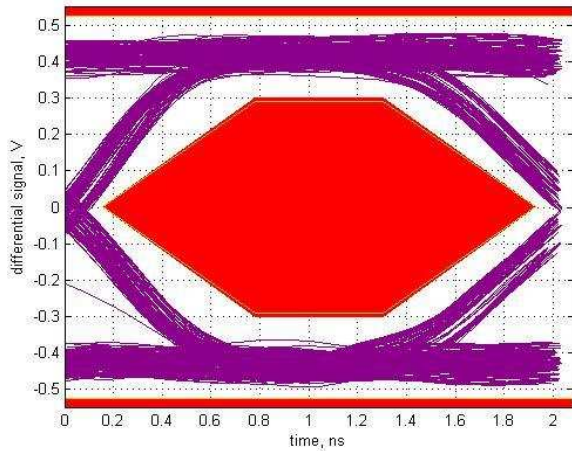

⊠ 14. Mid DC Boost, AC Boost Level 1

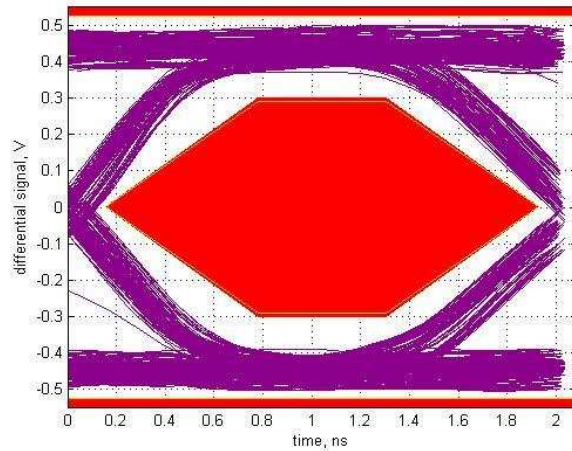

⊠ 15. High DC Boost, AC Boost Level 1

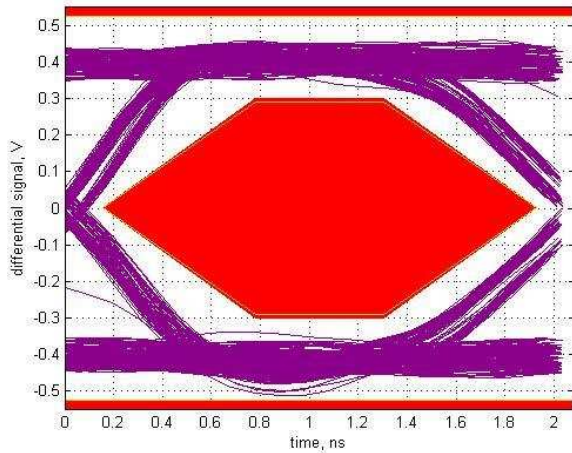

⊠ 16. Low DC Boost, AC Boost Level 2

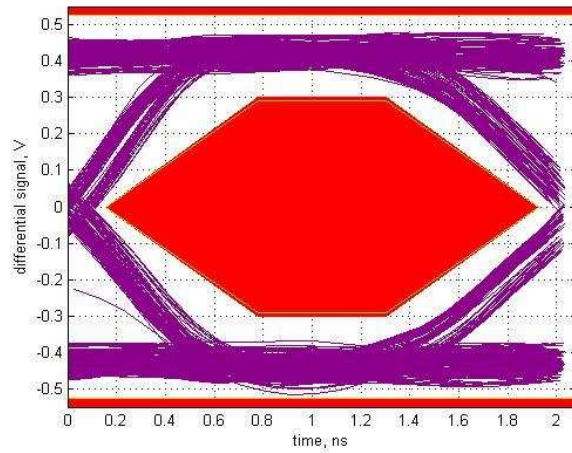

⊠ 17. Mid DC Boost, AC Boost Level 2

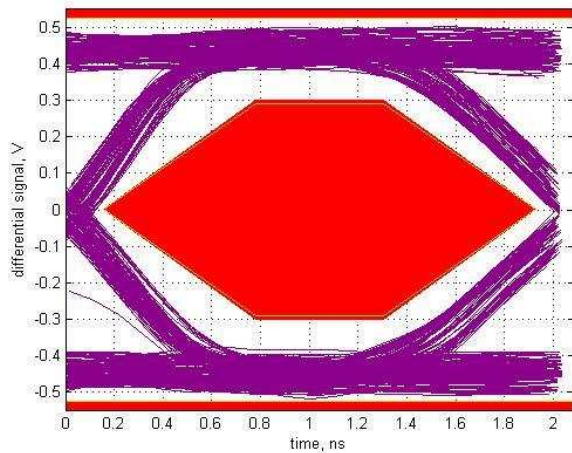

⊠ 18. High DC Boost, AC Boost Level 2

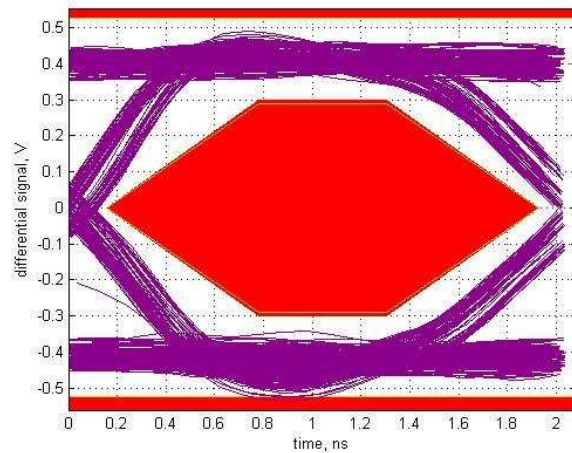

⊠ 19. Low DC Boost, AC Boost Level 3

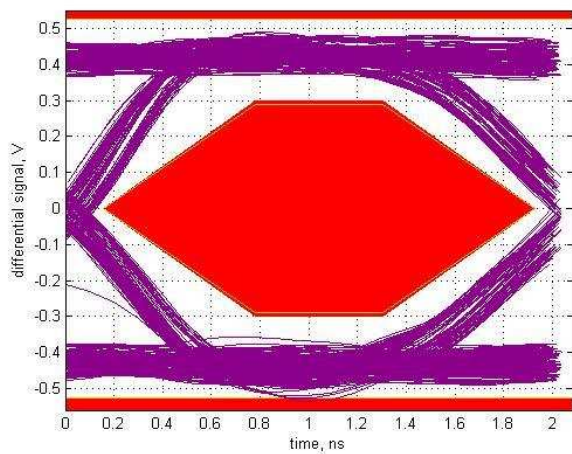

⊠ 20. Mid DC Boost, AC Boost Level 3

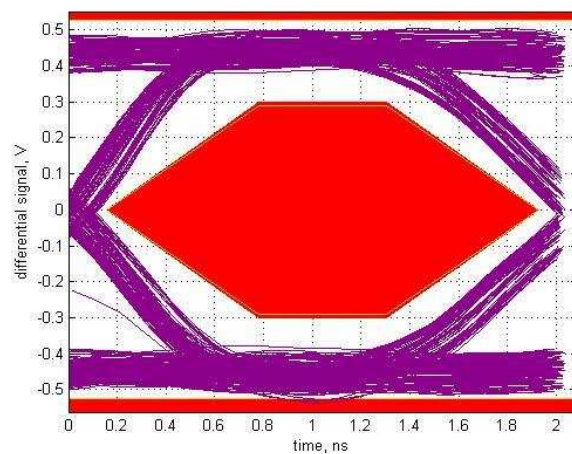

⊠ 21. High DC Boost, AC Boost Level 3



## 9 Power Supply Recommendations

On power up, the interaction of the RSTN pin and power on ramp could result in digital circuits not being set correctly. The device should not be enabled until the power on ramp has settled to 3 V or higher to ensure a correct power on reset of the digital circuitry. If RSTN cannot be held low by microcontroller or other circuitry until the power on ramp has settled, then an external capacitor from the RSTN pin to GND is required to hold the device in the low power reset state.

The RC time constant should be larger than five times of the power on ramp time (0 to  $V_{CC}$ ). With a typical internal pullup resistance of 500 k $\Omega$ , the recommended minimum external capacitance is calculated as:

$$[\text{Ramp Time} \times 5] \div [500 \text{ k}\Omega] \quad (1)$$

## 10 Layout

### 10.1 Layout Guidelines

The USB signal trace must not be broken when placing TUSB212-Q1. Thus, even with the TUSB212-Q1 powered down, or not populated, the USB link is still fully operational. To avoid the need for signal vias, it is highly recommend to route the High Speed traces directly underneath the TUSB212-Q1 package, as illustrated in the PCB land pattern shown in [Figure 22](#).

Although the land pattern shown below has matched trace width to pad width, optimal impedance control is based on the user's own PCB stack-up. It is recommended to maintain 90  $\Omega$  differential routing underneath the device.

All dimensions are in millimetres (mm).

### 10.2 Layout Example

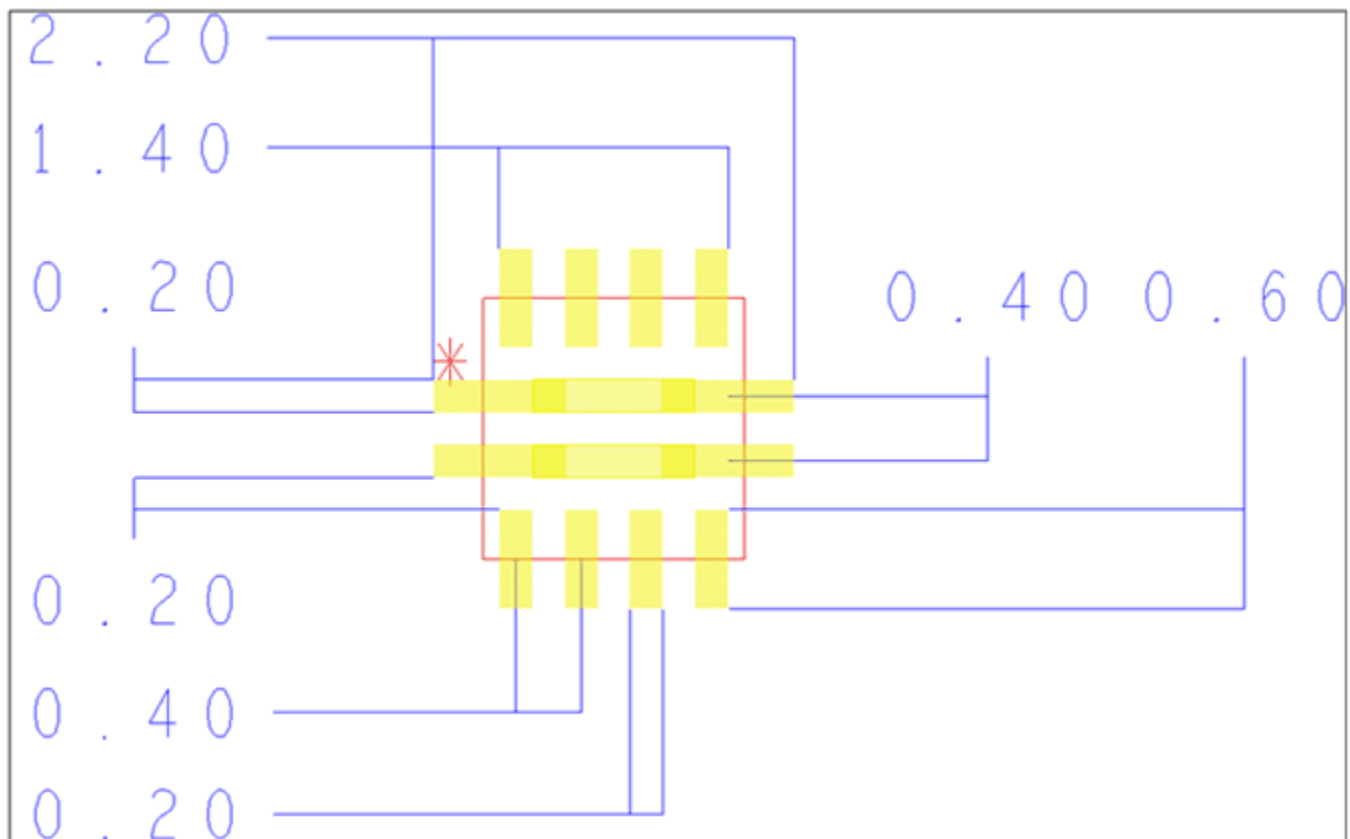

**Figure 22. DP and DM Routing Underneath Device Package**

## 11 デバイスおよびドキュメントのサポート

### 11.1 ドキュメントのサポート

### 11.2 ドキュメントの更新通知を受け取る方法

ドキュメントの更新についての通知を受け取るには、[ti.com](http://ti.com)のデバイス製品フォルダを開いてください。右上の隅にある「通知を受け取る」をクリックして登録すると、変更されたすべての製品情報に関するダイジェストを毎週受け取れます。変更の詳細については、修正されたドキュメントに含まれている改訂履歴をご覧ください。

### 11.3 コミュニティ・リソース

The following links connect to TI community resources. Linked contents are provided "AS IS" by the respective contributors. They do not constitute TI specifications and do not necessarily reflect TI's views; see TI's [Terms of Use](#).

**TI E2E™オンライン・コミュニティ** *TIのE2E ( Engineer-to-Engineer )* コミュニティ。エンジニア間の共同作業を促進するために開設されたものです。e2e.ti.comでは、他のエンジニアに質問し、知識を共有し、アイデアを検討して、問題解決に役立てることができます。

**設計サポート** *TIの設計サポート* 役に立つE2Eフォーラムや、設計サポート・ツールをすばやく見つけることができます。技術サポート用の連絡先情報も参照できます。

### 11.4 商標

E2E is a trademark of Texas Instruments.  
All other trademarks are the property of their respective owners.

### 11.5 静電気放電に関する注意事項



すべての集積回路は、適切なESD保護方法を用いて、取扱いと保存を行うようにして下さい。

静電気放電はわずかな性能の低下から完全なデバイスの故障に至るまで、様々な損傷を与えます。高精度の集積回路は、損傷に対して敏感であり、極めてわずかなパラメータの変化により、デバイスに規定された仕様に適合しなくなる場合があります。

### 11.6 Glossary

[SLYZ022](#) — *TI Glossary*.

This glossary lists and explains terms, acronyms, and definitions.

## 12 メカニカル、パッケージ、および注文情報

以降のページには、メカニカル、パッケージ、および注文に関する情報が記載されています。この情報は、そのデバイスについて利用可能な最新のデータです。このデータは予告なく変更されることがあり、ドキュメントが改訂される場合もあります。本データシートのブラウザ版を使用されている場合は、画面左側の説明をご覧ください。

**PACKAGING INFORMATION**

Orderable Device	Status (1)	Package Type	Package Drawing	Pins	Package Qty	Eco Plan (2)	Lead finish/ Ball material (6)	MSL Peak Temp (3)	Op Temp (°C)	Device Marking (4/5)	Samples
TUSB212QRWBRQ1	ACTIVE	X2QFN	RWB	12	3000	RoHS & Green	NIPDAU	Level-2-260C-1 YEAR	-40 to 105	22	<b>Samples</b>
TUSB212QRWBTQ1	ACTIVE	X2QFN	RWB	12	250	RoHS & Green	NIPDAU	Level-2-260C-1 YEAR	-40 to 105	22	<b>Samples</b>

(1) The marketing status values are defined as follows:

**ACTIVE:** Product device recommended for new designs.

**LIFEBUY:** TI has announced that the device will be discontinued, and a lifetime-buy period is in effect.

**NRND:** Not recommended for new designs. Device is in production to support existing customers, but TI does not recommend using this part in a new design.

**PREVIEW:** Device has been announced but is not in production. Samples may or may not be available.

**OBsolete:** TI has discontinued the production of the device.

(2) **RoHS:** TI defines "RoHS" to mean semiconductor products that are compliant with the current EU RoHS requirements for all 10 RoHS substances, including the requirement that RoHS substance do not exceed 0.1% by weight in homogeneous materials. Where designed to be soldered at high temperatures, "RoHS" products are suitable for use in specified lead-free processes. TI may reference these types of products as "Pb-Free".

**RoHS Exempt:** TI defines "RoHS Exempt" to mean products that contain lead but are compliant with EU RoHS pursuant to a specific EU RoHS exemption.

**Green:** TI defines "Green" to mean the content of Chlorine (Cl) and Bromine (Br) based flame retardants meet JS709B low halogen requirements of <=1000ppm threshold. Antimony trioxide based flame retardants must also meet the <=1000ppm threshold requirement.

(3) MSL, Peak Temp. - The Moisture Sensitivity Level rating according to the JEDEC industry standard classifications, and peak solder temperature.

(4) There may be additional marking, which relates to the logo, the lot trace code information, or the environmental category on the device.

(5) Multiple Device Markings will be inside parentheses. Only one Device Marking contained in parentheses and separated by a "~" will appear on a device. If a line is indented then it is a continuation of the previous line and the two combined represent the entire Device Marking for that device.

(6) Lead finish/Ball material - Orderable Devices may have multiple material finish options. Finish options are separated by a vertical ruled line. Lead finish/Ball material values may wrap to two lines if the finish value exceeds the maximum column width.

**Important Information and Disclaimer:**The information provided on this page represents TI's knowledge and belief as of the date that it is provided. TI bases its knowledge and belief on information provided by third parties, and makes no representation or warranty as to the accuracy of such information. Efforts are underway to better integrate information from third parties. TI has taken and continues to take reasonable steps to provide representative and accurate information but may not have conducted destructive testing or chemical analysis on incoming materials and chemicals. TI and TI suppliers consider certain information to be proprietary, and thus CAS numbers and other limited information may not be available for release.

In no event shall TI's liability arising out of such information exceed the total purchase price of the TI part(s) at issue in this document sold by TI to Customer on an annual basis.



**TAPE AND REEL INFORMATION**

**QUADRANT ASSIGNMENTS FOR PIN 1 ORIENTATION IN TAPE**



\*All dimensions are nominal

Device	Package Type	Package Drawing	Pins	SPQ	Reel Diameter (mm)	Reel Width W1 (mm)	A0 (mm)	B0 (mm)	K0 (mm)	P1 (mm)	W (mm)	Pin1 Quadrant
TUSB212QRWBRQ1	X2QFN	RWB	12	3000	180.0	9.5	1.8	1.8	0.45	4.0	8.0	Q1
TUSB212QRWBTQ1	X2QFN	RWB	12	250	180.0	9.5	1.8	1.8	0.45	4.0	8.0	Q1

**TAPE AND REEL BOX DIMENSIONS**

\*All dimensions are nominal

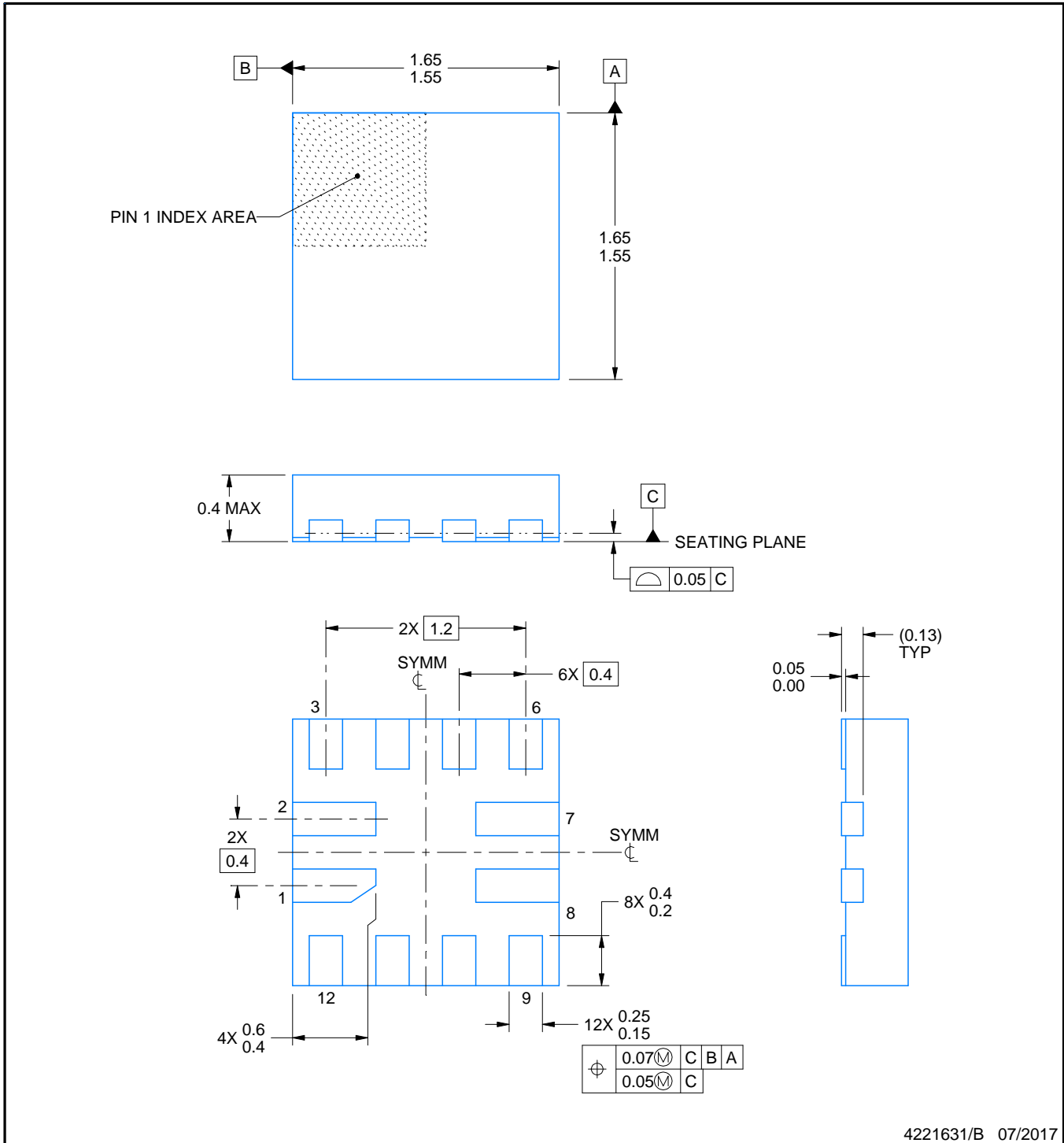
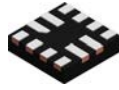
Device	Package Type	Package Drawing	Pins	SPQ	Length (mm)	Width (mm)	Height (mm)
TUSB212QRWBRQ1	X2QFN	RWB	12	3000	189.0	185.0	36.0
TUSB212QRWBTQ1	X2QFN	RWB	12	250	189.0	185.0	36.0



4221631/B 07/2017

NOTES:

1. All linear dimensions are in millimeters. Any dimensions in parenthesis are for reference only. Dimensioning and tolerancing per ASME Y14.5M.
2. This drawing is subject to change without notice.



# EXAMPLE BOARD LAYOUT

RWB0012A

X2QFN - 0.4 mm max height

PLASTIC QUAD FLATPACK - NO LEAD

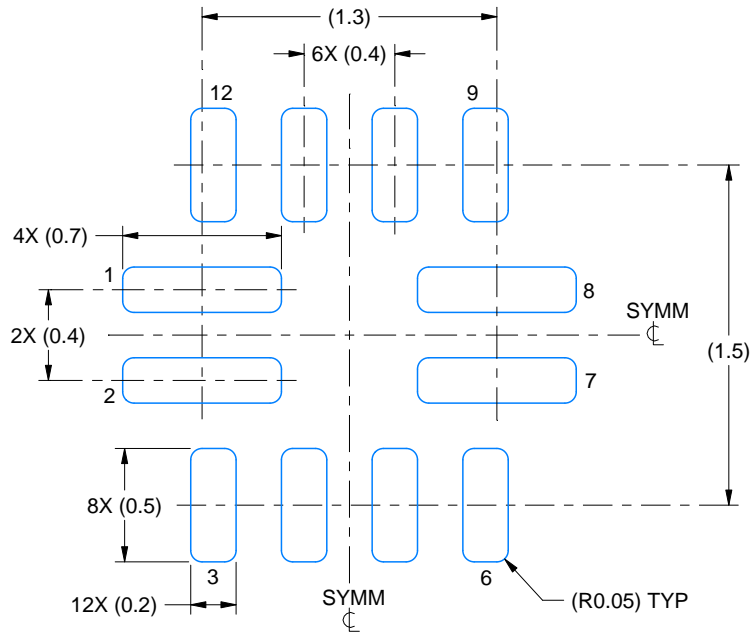

LAND PATTERN EXAMPLE  
EXPOSED METAL SHOWN  
SCALE:30X

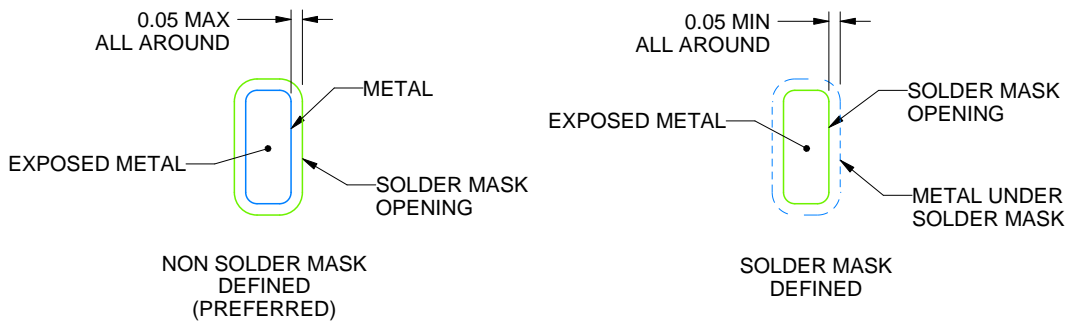

SOLDER MASK DETAILS

4221631/B 07/2017

NOTES: (continued)

3. For more information, see Texas Instruments literature number SLUA271 ([www.ti.com/lit/slua271](http://www.ti.com/lit/slua271)).

# EXAMPLE STENCIL DESIGN

RWB0012A

X2QFN - 0.4 mm max height

PLASTIC QUAD FLATPACK - NO LEAD

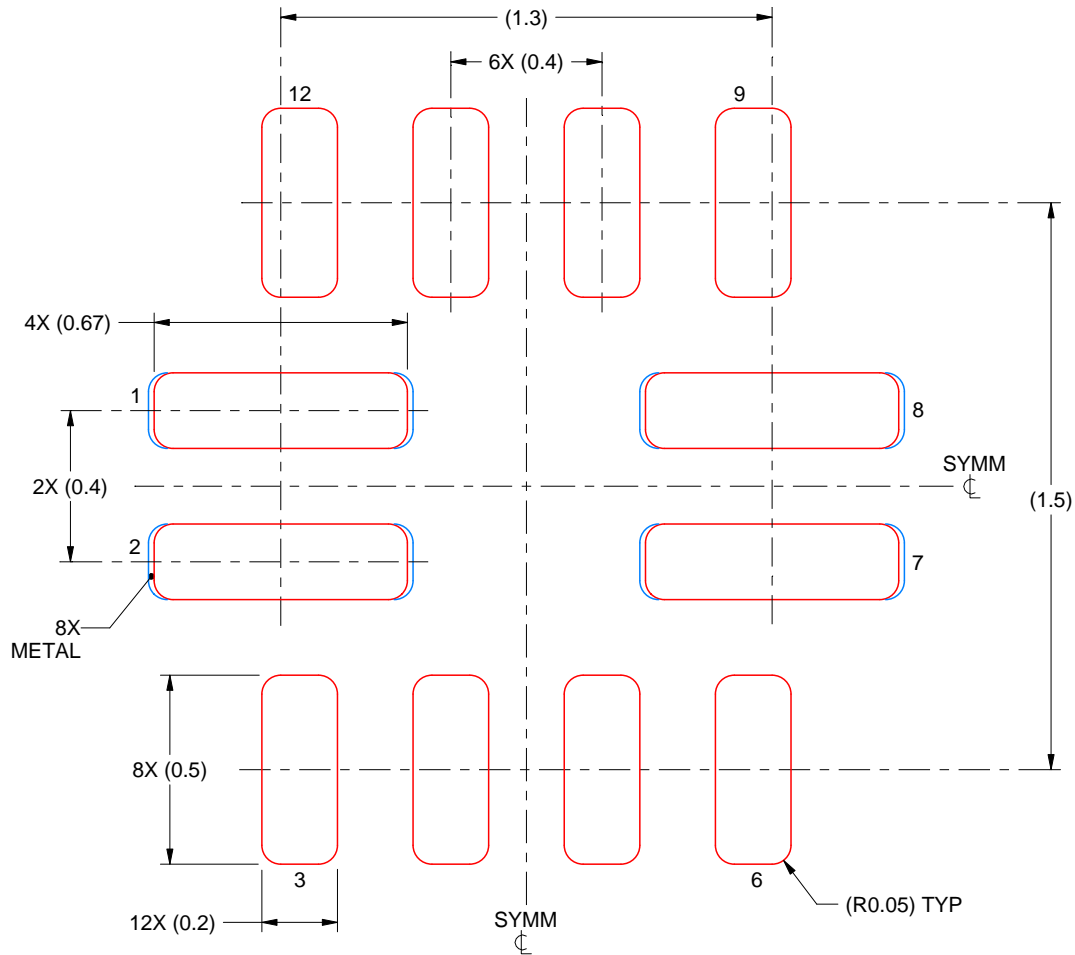

**SOLDER PASTE EXAMPLE**  
BASED ON 0.1 mm THICK STENCIL  
PADS 1,2,7 & 8  
96% PRINTED SOLDER COVERAGE BY AREA  
SCALE:50X

4221631/B 07/2017

NOTES: (continued)

4. Laser cutting apertures with trapezoidal walls and rounded corners may offer better paste release. IPC-7525 may have alternate design recommendations.

## 重要なお知らせと免責事項

TI は、技術データと信頼性データ (データシートを含みます)、設計リソース (リファレンス・デザインを含みます)、アプリケーションや設計に関する各種アドバイス、Web ツール、安全性情報、その他のリソースを、欠陥が存在する可能性のある「現状のまま」提供しており、商品性および特定目的に対する適合性の黙示保証、第三者の知的財産権の非侵害保証を含むいかなる保証も、明示的または黙示的にかかわらず拒否します。

これらのリソースは、TI 製品を使用する設計の経験を積んだ開発者への提供を意図したものです。(1) お客様のアプリケーションに適した TI 製品の選定、(2) お客様のアプリケーションの設計、検証、試験、(3) お客様のアプリケーションに該当する各種規格や、その他のあらゆる安全性、セキュリティ、規制、または他の要件への確実な適合に関する責任を、お客様のみが単独で負うものとし、

上記の各種リソースは、予告なく変更される可能性があります。これらのリソースは、リソースで説明されている TI 製品を使用するアプリケーションの開発の目的でのみ、TI はその使用をお客様に許諾します。これらのリソースに関して、他の目的で複製することや掲載することは禁止されています。TI や第三者の知的財産権のライセンスが付与されている訳ではありません。お客様は、これらのリソースを自身で使用した結果発生するあらゆる申し立て、損害、費用、損失、責任について、TI およびその代理人を完全に補償するものとし、TI は一切の責任を拒否します。

TI の製品は、[TI の販売条件](#)、または [ti.com](https://www.ti.com) やかかる TI 製品の関連資料などのいずれかを通じて提供する適用可能な条項の下で提供されています。TI がこれらのリソースを提供することは、適用される TI の保証または他の保証の放棄の拡大や変更を意味するものではありません。

お客様がいかなる追加条項または代替条項を提案した場合でも、TI はそれらに異議を唱え、拒否します。

郵送先住所 : Texas Instruments, Post Office Box 655303, Dallas, Texas 75265  
Copyright © 2023, Texas Instruments Incorporated