

UCCx81xA BiCMOS 力率プリレギュレータ

1 特長

- 昇圧プリレギュレータをユニティに近い力率に制御
- ライン歪みを制限
- ワールドワイド電源ラインに対応
- 過電圧保護
- 高精度の電力制限
- 平均電流モード制御
- ノイズ耐性の向上
- フィード・フォワード・ライン・レギュレーションの改良
- リーディング・エッジ変調方式
- 起動電流の標準値: 150μA
- 低消費電力のBiCMOS動作
- 12V~17Vで動作
- 6kHz~220kHzの周波数範囲

2 アプリケーション

- PC電源
- コンシューマ・エレクトロニクス
- ライティング
- 産業用電源
- IEC6100-3-2準拠の電源(300W未満)

3 概要

UCC3817AおよびUCC3818Aファミリは、アクティブ力率補正プリレギュレータに必要なすべての機能が搭載されています。コントローラは、AC入力ラインの電流波形を、AC入力ライン電圧の波形に対応するよう成形し、ユニティに近い力率を実現します。平均電流モード制御により、安定した低歪みの正弦ライン電流が維持されます。

UCC3817A/UCC3818Aはテキサス・インスツルメンツのBiCMOSプロセスで設計されており、低いスタートアップ電流、低消費電力、過電圧保護、シャントUVLO検出回路、リーディング・エッジ変調技法によるバルク・コンデンサのリップル電流低減、改良された低オフセット(±2mV)電流アンプによる軽負荷時の歪み低減などの新機能があります。

製品情報⁽¹⁾

型番	パッケージ	本体サイズ(公称)
UCCx81xA	SOIC (16)	4.90mm×3.91mm
	PDIP (16)	19.30mm×6.35mm
	TSSOP (16)	5.00mm×4.40mm

(1) 提供されているすべてのパッケージについては、データシートの末尾にある注文情報を参照してください。

ブロック図

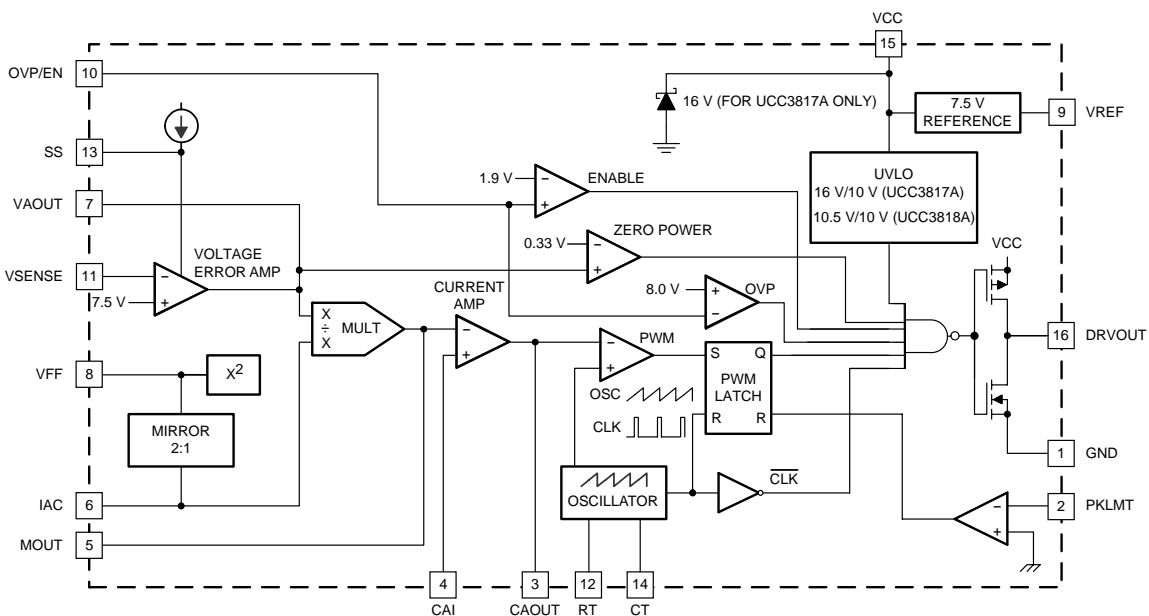

Copyright © 2016, Texas Instruments Incorporated



目次

1	特長	1	9.3	Feature Description	9
2	アプリケーション	1	9.4	Device Functional Modes	12
3	概要	1	10	Application and Implementation	14
4	改訂履歴	2	10.1	Application Information	14
5	概要(続き)	3	10.2	Typical Application	15
6	Device Comparison Tables	3	11	Power Supply Recommendations	25
7	Pin Configuration and Functions	4	12	Layout	25
8	Specifications	5	12.1	Layout Guidelines	25
8.1	Absolute Maximum Ratings	5	12.2	Layout Example	25
8.2	ESD Ratings	5	13	デバイスおよびドキュメントのサポート	26
8.3	Recommended Operating Conditions	5	13.1	ドキュメントのサポート	26
8.4	Thermal Information	6	13.2	関連リンク	26
8.5	Electrical Characteristics	6	13.3	ドキュメントの更新通知を受け取る方法	26
8.6	Typical Characteristics	8	13.4	コミュニティ・リソース	26
9	Detailed Description	9	13.5	商標	26
9.1	Overview	9	13.6	静電気放電に関する注意事項	26
9.2	Functional Block Diagram	9	13.7	Glossary	26
			14	メカニカル、パッケージ、および注文情報	27

4 改訂履歴

資料番号末尾の英字は改訂を表しています。その改訂履歴は英語版に準じています。

Revision C (November 2011) から Revision D に変更

Page

• 「ESD定格」表、「機能説明」セクション、「デバイスの機能モード」セクション、「アプリケーションと実装」セクション、「電源に関する推奨事項」セクション、「レイアウト」セクション、「デバイスおよびドキュメントのサポート」セクション、「メカニカル、パッケージ、および注文情報」セクション 追加	1
• Changed the $R_{\theta JA}$ and $R_{\theta JC(top)}$ thermal values for all packages	6
• Combined the <i>Electrical Characteristics</i> tables	6

5 概要(続き)

UCC3817A/18AファミリのPFCコントローラは、UCC3817/18ファミリのデバイスと直接ピン単位で互換性があります。UCC3817Aファミリの出力ステージのみが、小さな値の外付けゲート・ドライブ抵抗を使用できるように変更されています。十分に高いゲート・ドライブ抵抗を使用できない一部の電源デザイン用に、UCC3817A/18Aファミリでは内部のゲート抵抗を大きくすることで、出力ステージをより強固にしています。それでも、UCC3817A/18Aファミリのゲート・ドライブは引き続き強力であり、 $\pm 1.2\text{A}$ のピーク電流能力を持っています。

UCC3817Aにはスタートアップ電流の低いオンチップのシャント・レギュレータがあり、ブートストラップ電源を活用するアプリケーションに適しています。UCC3818Aは、固定電源電圧(VCC)のアプリケーションを対象としています。どちらのデバイスも、16ピンのD、N、PWパッケージで供給されます。

6 Device Comparison Tables

Table 1. Available Options

$T_A = T_J$	PACKAGE DEVICES					
	SOIC (D) PACKAGE ⁽¹⁾		PDIP (N) PACKAGE		TSSOP (PW) PACKAGE ⁽¹⁾	
	TURNON THRESHOLD 16 V	TURNON THRESHOLD 10.2 V	TURNON THRESHOLD 16 V	TURNON THRESHOLD 10.2 V	TURNON THRESHOLD 16 V	TURNON THRESHOLD 10.2 V
-40°C to 85°C	UCC2817AD	UCC2818AD	UCC2817AN	UCC2818AN	UCC2817APW	UCC2818APW
0°C to 70°C	UCC3817AD	UCC3818AD	UCC3817AN	UCC3818AN	UCC3817APW	UCC3818APW

- (1) The D and PW packages are available taped and reeled. Add R suffix to the device type (e.g. UCC3817ADR) to order quantities of 2,500 devices per reel (D package) and 2,000 devices per reel (for PW package). Bulk quantities are 40 units (D package) and 90 units (PW package) per tube.

Table 2. Related Products

DEVICE	DESCRIPTION	CONTROL METHOD	TYPICAL POWER LEVEL
UC3854	PFC controller	ACM ⁽¹⁾	200 W to 2 kW+
UC3854A/B	Improved PFC controller	ACM ⁽¹⁾	200 W to 2 kW+
UC3855A/B	High performance soft switching PFC controller	ACM ⁽¹⁾	400 W to 2 kW+
UCC38050/1	Transition mode PFC controller	CRM ⁽²⁾	50 W to 400 W
UCC3819	Tracking boost PFC controller	ACM ⁽¹⁾	75 W to 2 kW+
UCC28510/11/12/13	Advanced PFC+PWM combo controller	ACM ⁽¹⁾	75 W to 1kW+
UCC28514/15/16/17	Advanced PFC+PWM combo controller	ACM ⁽¹⁾	75 W to 1kW+

- (1) Average current mode
(2) Critical conduction mode

7 Pin Configuration and Functions

**D, N, and PW Packages
16-Pin SOIC, PDIP, and TSSOP
Top View**

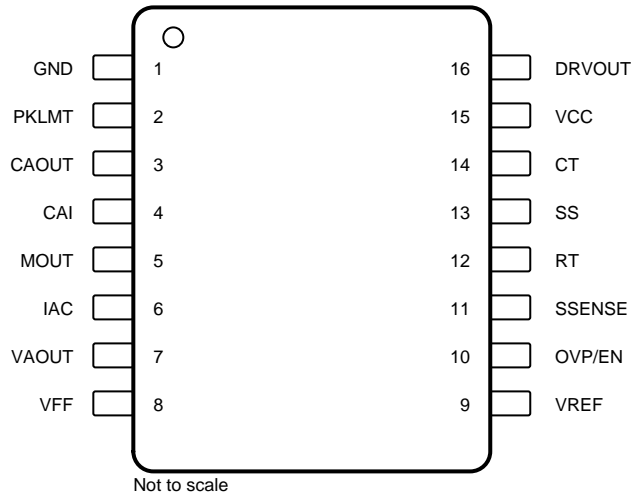

Pin Functions

PIN		I/O	DESCRIPTION
NO.	NAME		
4	CAI	I	Current amplifier noninverting input
3	CAOUT	O	Current amplifier output
14	CT	I	Oscillator timing capacitor
16	DRVOUT	O	Gate drive
1	GND	—	Ground
6	IAC	I	Current proportional to input voltage
5	MOUT	I/O	Multiplier output and current amplifier inverting input
10	OVP/EN	I	Overvoltage/enable
2	PKLMT	I	PFC peak current limit
12	RT	I	Oscillator charging current
13	SS	I	Soft-start
7	VAOUT	O	Voltage amplifier output
15	VCC	I	Positive supply voltage
8	VFF	I	Feed-forward voltage
11	SSSENSE	I	Voltage amplifier inverting input
9	VREF	O	Voltage reference output

8 Specifications

8.1 Absolute Maximum Ratings

over operating free-air temperature range (unless otherwise noted)⁽¹⁾

	MIN	MAX	UNIT
Supply voltage VCC		18	V
Supply current ICC		20	mA
Gate drive current, continuous		0.2	A
Gate drive current		1.2	A
Input voltage, CAI, MOUT, SS		8	V
Input voltage, PKLMT		5	V
Input voltage, VSENSE, OVP/EN		10	V
Input current, RT, IAC, PKLMT		10	mA
Input current, VCC (no switching)		20	mA
Maximum negative voltage, DRVOUT, PKLMT, MOUT	-0.5		V
Power dissipation		1	W
Lead temperature, T _{sol} (soldering, 10 seconds)		300	°C
Power dissipation		1	W
Junction temperature, T _J	-55	150	°C
Storage temperature, T _{stg}	-65	150	°C

- (1) Stresses beyond those listed under *Absolute Maximum Ratings* may cause permanent damage to the device. These are stress ratings only, which do not imply functional operation of the device at these or any other conditions beyond those indicated under *Recommended Operating Conditions*. Exposure to absolute-maximum-rated conditions for extended periods may affect device reliability.

8.2 ESD Ratings

		VALUE	UNIT
V _(ESD)	Electrostatic discharge		V
	Human-body model (HBM), per ANSI/ESDA/JEDEC JS-001 ⁽¹⁾	±2000	
	Charged-device model (CDM), per JEDEC specification JESD22-C101 ⁽²⁾	±1500	

- (1) JEDEC document JEP155 states that 500-V HBM allows safe manufacturing with a standard ESD control process.
(2) JEDEC document JEP157 states that 250-V CDM allows safe manufacturing with a standard ESD control process.

8.3 Recommended Operating Conditions

over operating free-air temperature range (unless otherwise noted)

		MIN	NOM	MAX	UNIT
VCC	Input voltage		12	18	V
VSENSE	Input sense voltage		7.5	10	V
	Input current for oscillator		1.36	10	mA

8.4 Thermal Information

THERMAL METRIC ⁽¹⁾		UCCx81xA			UNIT
		D (SOIC)	N (PDIP)	PW (TSSOP)	
		16 PINS	16 PINS	16 PINS	
R _{θJA}	Junction-to-ambient thermal resistance	73.9	49.3	98.9	°C/W
R _{θJC(top)}	Junction-to-case (top) thermal resistance	33.5	38.9	30.2	°C/W
R _{θJB}	Junction-to-board thermal resistance	31.4	29.4	44.8	°C/W
ψ _{JT}	Junction-to-top characterization parameter	5.8	18.9	1.9	°C/W
ψ _{JB}	Junction-to-board characterization parameter	31.1	29.2	44.1	°C/W

(1) For more information about traditional and new thermal metrics, see the [Semiconductor and IC Package Thermal Metrics](#) application report.

8.5 Electrical Characteristics

T_A = 0°C to 70°C for the UCC3817A and T_A = -40°C to 85°C for the UCC2817A, T_A = T_J, V_{CC} = 12 V, R_T = 22 kΩ, C_T = 270 pF, (unless otherwise noted)

PARAMETER	TEST CONDITIONS	MIN	TYP	MAX	UNIT
SUPPLY CURRENT SECTION					
Supply current, OFF	V _{CC} = (V _{CC} turnon threshold - 0.3 V)		150	300	μA
Supply current, ON	V _{CC} = 12 V, No load on DRVOUT	2	4	6	mA
UVLO SECTION					
V _{CC} turnon threshold (UCCx817)		15.4	16	16.6	V
V _{CC} turnoff threshold (UCCx817)		9.4	9.7		V
UVLO hysteresis (UCCx817)		5.8	6.3		V
Maximum shunt voltage (UCCx817)	I _{VCC} = 10 mA	15.4	17	17.5	V
V _{CC} turnon threshold (UCCx818)		9.7	10.2	10.8	V
V _{CC} turnoff threshold (UCCx818)		9.4	9.7		V
UVLO hysteresis (UCCx818)		0.3	0.5		V
VOLTAGE AMPLIFIER SECTION					
Input voltage	T _A = 0°C to 70°C	7.387	7.5	7.613	V
	T _A = -40°C to 85°C	7.369	7.5	7.631	
V _{SENSE} bias current	V _{SENSE} = V _{REF} , V _{AO} = 2.5 V		50	200	nA
Open-loop gain	V _{AO} = 2 V to 5 V	50	90		dB
High-level output voltage	I _L = -150 μA	5.3	5.5	5.6	V
Low-level output voltage	I _L = 150 μA	0	50	150	mV
OVER VOLTAGE PROTECTION AND ENABLE SECTION					
Over voltage reference		V _{REF} +0.48	V _{REF} +0.50	V _{REF} +0.52	V
Hysteresis		300	500	600	mV
Enable threshold		1.7	1.9	2.1	V
Enable hysteresis		0.1	0.	0.3	V
CURRENT AMPLIFIER SECTION					
Input offset voltage	V _{CM} = 0 V, V _{CAOUT} = 3 V	-3.5	0	2.5	mV
Input bias current	V _{CM} = 0 V, V _{CAOUT} = 3 V		-50	-100	nA
Input offset current	V _{CM} = 0 V, V _{CAOUT} = 3 V		25	100	nA
Open loop gain	V _{CM} = 0 V, V _{CAOUT} = 2 V to 5 V	90			dB
Common-mode output voltage	V _{CM} = 0 V to 1.5 V, V _{CAOUT} = 3 V	60	80		dB
High-level output voltage	I _L = -120 mA	5.6	6.5	6.8	VV
Low-level output voltage	I _L = 1 mA	0.1	0.2	0.5	MHz
Gain bandwidth product	See ⁽¹⁾		2.5		

(1) Ensured by design, not production tested.

Electrical Characteristics (continued)

$T_A = 0^\circ\text{C}$ to 70°C for the UCC3817A and $T_A = -40^\circ\text{C}$ to 85°C for the UCC2817A, $T_A = T_J$, $V_{CC} = 12\text{ V}$, $R_T = 22\text{ k}\Omega$, $C_T = 270\text{ pF}$, (unless otherwise noted)

PARAMETER	TEST CONDITIONS	MIN	TYP	MAX	UNIT
VOLTAGE REFERENCE SECTION					
Input voltage	$T_A = 0^\circ\text{C}$ to 70°C	7.387	7.5	7.613	V
	$T_A = -40^\circ\text{C}$ to 85°C	7.369	7.5	7.631	
Load regulation	$I_{REF} = 1\text{ mA}$ to 2 mA	0		10	mV
Line regulation	$V_{CC} = 10.8$ to $15\text{ V}^{(2)}$	0		10	mV
Short-circuit current	$V_{REF} = 0\text{ V}$	-20	-25	-50	mA
OSCILLATOR SECTION					
Initial accuracy	$T_A = 25^\circ\text{C}$	85	100	115	kHz
Voltage stability	$V_{CC} = 10.8$ to 15 V	-1%		1%	
Total variation	Line, temp	80		120	kHz
Ramp peak voltage		4.5	5	5.5	V
Ramp amplitude voltage (peak to peak)		3.5	4	4.5	V
PEAK CURRENT LIMIT SECTION					
PKLMT reference voltage		-15		15	mV
PKLMT propagation delay		150	350	500	ns
MULTIPLIER SECTION					
I_{MOUT} , high line, low power output current, (0°C to 85°C)	$I_{AC} = 500\text{ }\mu\text{A}$, $V_{FF} = 4.7\text{ V}$, $VA_{OUT} = 1.25\text{ V}$	0	-6	-20	μA
I_{MOUT} , high line, low power output current, (-40°C to 85°C)	$I_{AC} = 500\text{ }\mu\text{A}$, $V_{FF} = 4.7\text{ V}$, $VA_{OUT} = 1.25\text{ V}$	0	-6	-23	
I_{MOUT} , high line, low power output current	$I_{AC} = 500\text{ }\mu\text{A}$, $V_{FF} = 4.7\text{ V}$, $VA_{OUT} = 5\text{ V}$	-70	-90	-105	
I_{MOUT} , low line, low power output current	$I_{AC} = 150\text{ }\mu\text{A}$, $V_{FF} = 1.4\text{ V}$, $VA_{OUT} = 1.25\text{ V}$	-10	-19	-50	
I_{MOUT} , low line, high power output current	$I_{AC} = 150\text{ }\mu\text{A}$, $V_{FF} = 1.4\text{ V}$, $VA_{OUT} = 5\text{ V}$	-268	-300	-345	
I_{MOUT} , IAC limited output current	$I_{AC} = 150\text{ }\mu\text{A}$, $V_{FF} = 1.3\text{ V}$, $VA_{OUT} = 5\text{ V}$	-250	-300	-400	
Gain constant (K)	$I_{AC} = 150\text{ }\mu\text{A}$, $V_{FF} = 1.3\text{ V}$, $VA_{OUT} = 2.5\text{ V}$	0.5	1	1.5	1/V
I_{MOUT} , zero current	$I_{AC} = 150\text{ }\mu\text{A}$, $V_{FF} = 1.4\text{ V}$, $VA_{OUT} = 0.25\text{ V}$		0	-2	μA
	$I_{AC} = 500\text{ }\mu\text{A}$, $V_{FF} = 4.7\text{ V}$, $VA_{OUT} = 0.25\text{ V}$		0	-2	
I_{MOUT} , zero current, (0°C to 85°C)	$I_{AC} = 500\text{ }\mu\text{A}$, $V_{FF} = 4.7\text{ V}$, $VA_{OUT} = 0.5\text{ V}$		0	-3	μA
I_{MOUT} , zero current, (-40°C to 85°C)	$I_{AC} = 500\text{ }\mu\text{A}$, $V_{FF} = 4.7\text{ V}$, $VA_{OUT} = 0.5\text{ V}$		0	-3.5	μA
Power limit ($I_{MOUT} \times V_{FF}$)	$I_{AC} = 150\text{ }\mu\text{A}$, $V_{FF} = 1.4\text{ V}$, $VA_{OUT} = 5\text{ V}$	-375	-420	-485	μW
FEED-FORWARD SECTION					
VFF output current	$I_{AC} = 300\text{ }\mu\text{A}$	-140	-150	-160	μA
SOFT START SECTION					
SS charge current		-6	-10	-16	μA
GATE DRIVER SECTION					
Pullup resistance	$I_O = -100\text{ mA}$ to -200 mA		9	12	Ω
Pulldown resistance	$I_O = 100\text{ mA}$		4	10	
Output rise time	$C_L = 1\text{ nF}$, $R_L = 10\text{ }\Omega$, $V_{DRVOUT} = 0.7\text{ V}$ to 9 V		25	50	ns
Output fall time	$C_L = 1\text{ nF}$, $R_L = 10\text{ }\Omega$, $V_{DRVOUT} = 9\text{ V}$ to 0.7 V		10	50	
Maximum duty cycle		93%	95%	99%	
Minimum controlled duty cycle	At 100 kHz			2%	
ZERO POWER SECTION					
Zero power comparator threshold	Measured on VA_{OUT}	0.2	0.33	0.5	V

(2) Reference variation for $V_{CC} < 10.8\text{ V}$ is shown in [Figure 12](#).

8.6 Typical Characteristics

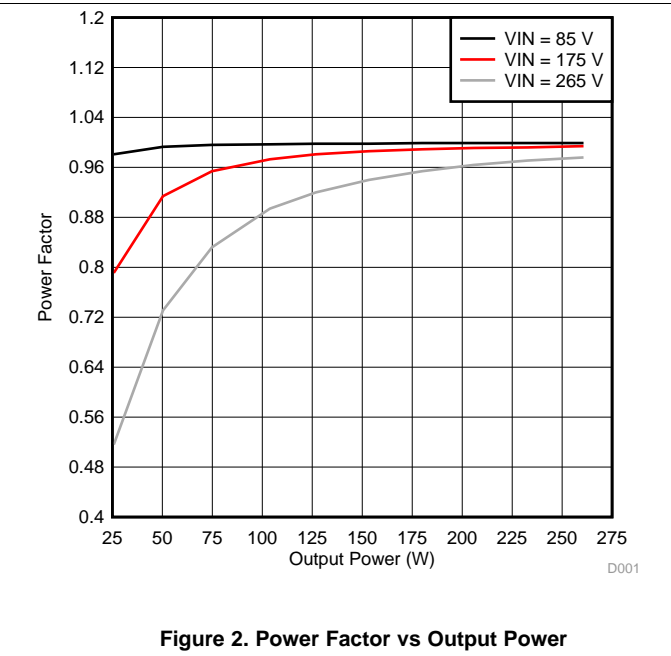
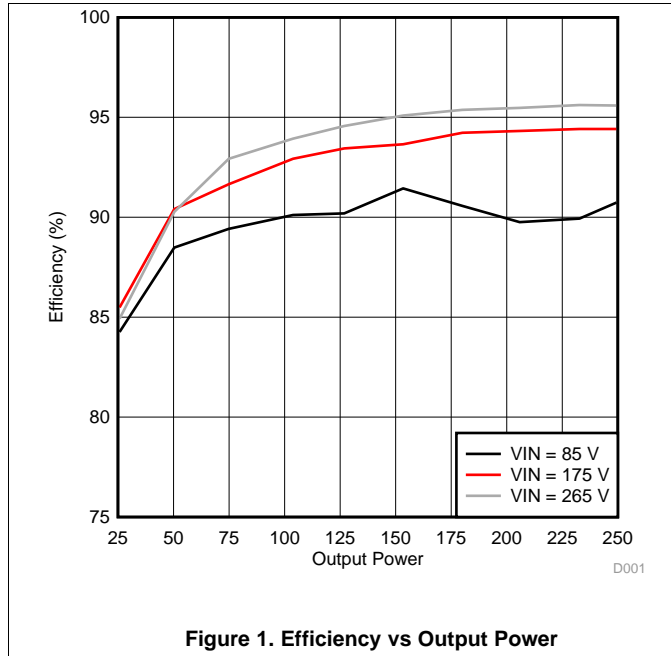

Feature Description (continued)

9.3.3 Multiplier

The multiplier has 3 inputs. The inputs to the multiplier are VAOUT, the voltage amplifier error signal, IAC, a representation of the input rectified AC line voltage, and an input voltage feedforward signal, VVFF.

The multiplier performs the calculation in [Equation 1](#).

$$I_{MOUNT} = IAC \times (VVAOUT - 1) / (K \times VVff^2)$$

where

- $K = 1/V$ (1)

As the multiplier output is a current, this is a high-impedance input so the amplifier can be configured as a differential amplifier. This configuration improves noise immunity and allows for the leading-edge modulation operation.

9.3.4 Output Overvoltage Protection

When the output voltage exceeds the OVP threshold, the IC stops switching. The OVP reference is at 1.07%. There is also a 500 mV of hysteresis at the pin.

9.3.5 Pin Descriptions

9.3.5.1 CAI

Place a resistor between this pin and the GND side of current sense resistor. This input and the inverting input (MOUT) remain functional down to and below GND.

9.3.5.2 CAOUT

This is the output of a wide bandwidth operational amplifier that senses line current and commands the PFC pulse-width modulator (PWM) to force the correct duty cycle. Compensation components are placed between CAOUT and MOUT.

9.3.5.3 CT

A capacitor from CT to GND sets the PWM oscillator frequency according to [Equation 2](#):

$$f \approx \left(\frac{0.6}{RT \times CT} \right)$$
 (2)

The lead from the oscillator timing capacitor to GND should be as short and direct as possible.

9.3.5.4 DRVOUT

The output drive for the boost switch is a totem-pole MOSFET gate driver on DRVOUT. To avoid the excessive overshoot of the DRVOUT while driving a capacitive load, a series gate current-limiting/damping resistor is recommended to prevent interaction between the gate impedance and the output driver. The value of the series gate resistor is based on the pulldown resistance ($R_{pull\down}$ which is 4 Ω typical), the maximum VCC voltage (VCC), and the required maximum gate drive current (I_{MAX}). Using [Equation 3](#), a series gate resistance of 11 Ω would be required for a maximum VCC voltage of 18 V and for 1.2 A of maximum sink current. The source current will be limited to approximately 900 mA (based on the $R_{pull\up}$ of 9- Ω typical).

$$R_{GATE} = \frac{VCC - (I_{MAX} \times R_{pull\down})}{I_{MAX}}$$
 (3)

9.3.5.5 GND

All voltages measured with respect to ground. VCC and REF should be bypassed directly to GND with a 0.1- μ F or larger ceramic capacitor.

Feature Description (continued)

9.3.5.6 I_{AC}

This input to the analog multiplier is a current proportional to instantaneous line voltage. The multiplier is tailored for very low distortion from this current input (I_{AC}) to multiplier output. The recommended maximum I_{AC} is 500 μ A.

9.3.5.7 M_{OUT}

The output of the analog multiplier and the inverting input of the current amplifier are connected together at M_{OUT}. As the multiplier output is a current, this is a high-impedance input so the amplifier can be configured as a differential amplifier. This configuration improves noise immunity and allows for the leading-edge modulation operation. The multiplier output current is limited to ($2 \times I_{AC}$). The multiplier output current is given by [Equation 4](#):

$$I_{MOUT} = \frac{I_{AC} \times (V_{VAOUT} - 1)}{V_{VFF}^2 \times K} \quad (4)$$

where $K = \frac{1}{V}$ is the multiplier gain constant.

9.3.5.8 OVP/EN

A window comparator input that disables the output driver if the boost output voltage is a programmed level above the nominal or disables both the PFC output driver and resets SS if pulled below 1.9 V (typical).

9.3.5.9 PKLMT

The threshold for peak limit is 0 V. Use a resistor divider from the negative side of the current sense resistor to VREF to level shift this signal to a voltage level defined by the value of the sense resistor and the peak current limit. Peak current limit is reached when PKLMT voltage falls below 0 V.

9.3.5.10 RT

A resistor from RT to GND is used to program oscillator charging current. TI recommends a resistor between 10 k Ω and 100 k Ω . Nominal voltage on this pin is 3 V.

9.3.5.11 SS

VSS is discharged for VVCC low conditions. When enabled, SS charges an external capacitor with a current source. This voltage is used as the voltage error signal during start-up, enabling the PWM duty cycle to increase slowly. In the event of a V_{VCC} dropout, the OVP/EN is forced below 1.9 V (typ), SS quickly discharges to disable the PWM.

NOTE

In an open-loop test circuit, grounding the SS pin does not ensure 0% duty cycle. See the application section for details.

9.3.5.12 VA_{OUT}

This is the output of the operational amplifier that regulates output voltage. The voltage amplifier output is internally limited to approximately 5.5 V to prevent overshoot.

9.3.5.13 VCC

Connect to a stable source of at least 20 mA from 10 V to 17 V for normal operation. Bypass VCC directly to GND to absorb supply current spikes required to charge external MOSFET gate capacitances. To prevent inadequate gate drive signals, the output devices are inhibited unless V_{VCC} exceeds the upper undervoltage lockout voltage threshold and remains above the lower threshold.

Feature Description (continued)

9.3.5.14 VFF

The RMS voltage signal generated at this pin by mirroring 1/2 of the I_{IAC} into a single pole external filter. At low line, the VFF voltage should be 1.4 V.

9.3.5.15 VSENSE

This is normally connected to a compensation network and to the boost converter output through a divider network.

9.3.5.16 VREF

VREF is the output of an accurate 7.5-V voltage reference. This output is capable of delivering 20 mA to peripheral circuitry and is internally short-circuit current limited. VREF is disabled and remains at 0 V when V_{VCC} is below the UVLO threshold. Bypass VREF to GND with a 0.1- μ F or larger ceramic capacitor for best stability. See [Figure 12](#) and [Figure 13](#) for VREF line and load regulation characteristics.

9.4 Device Functional Modes

9.4.1 Transition Mode Control

The boost converter, the most common topology used for power factor correction, can operate in two modes: continuous conduction mode (CCM) and discontinuous conduction mode (DCM). Transition mode control, also referred to as critical conduction mode (CRM) or boundary conduction mode, maintains the converter at the boundary between CCM and DCM by adjusting the switching frequency.

The CRM converter typically uses a variation of hysteretic control, with the lower boundary equal to zero current. It is a variable frequency control technique that has inherently stable input current control while eliminating reverse recovery rectifier losses. As shown in [Figure 3](#), the switch current is compared to the reference signal (output of the multiplier) directly. This control method has the advantage of simple implementation and good power factor correction.

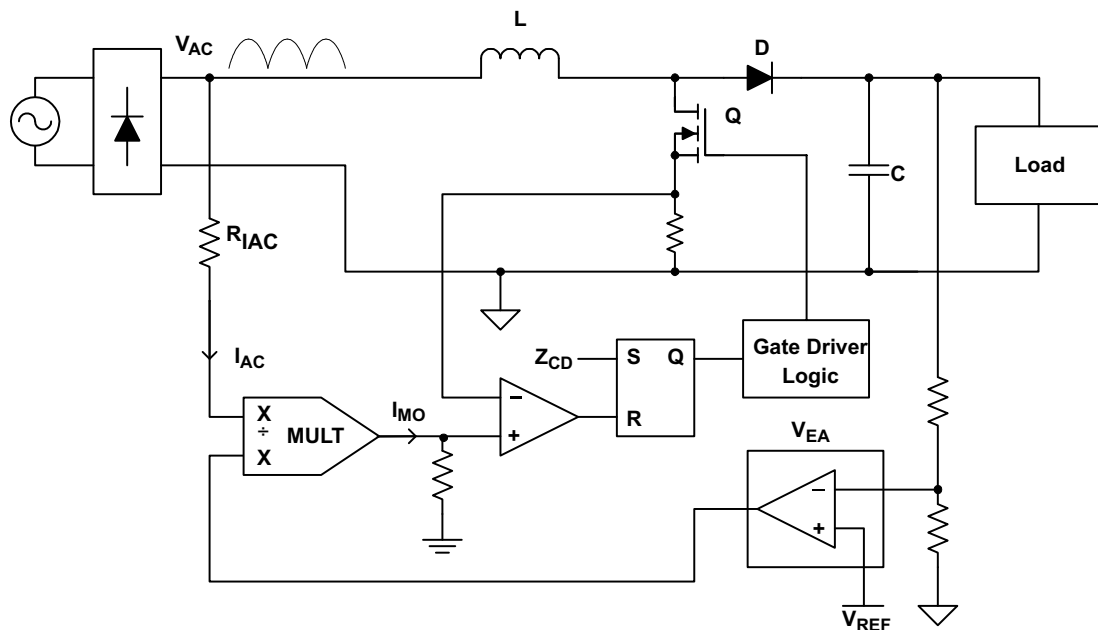

UDG-02124

Figure 3. Basic Block Diagram of CRM Boost PFC

Device Functional Modes (continued)

The power stage equations and the transfer functions of the CRM are the same as the CCM. However, implementations of the control functions are different. Transition mode forces the inductor current to operate just at the border of CCM and DCM. The current profile is also different, and affects the component power loss and filtering requirements. The peak current in the CRM boost is twice the amplitude of CCM, leading to higher conduction losses. The peak-to-peak ripple is twice the average current, which affects MOSFET switching losses and magnetics ac losses.

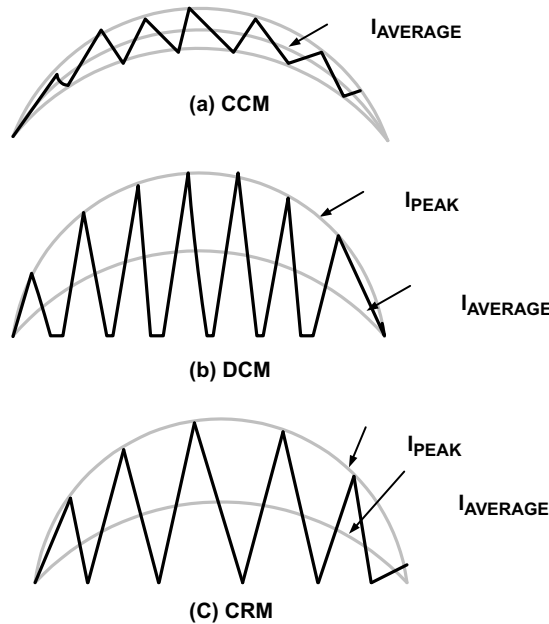

Note: Operating Frequency >> 120 Hz

UDG-02123

Figure 4. PFC Inductor Current Profiles

For low to medium power applications up to approximately 300 W, the CRM boost has an advantage in losses. The filtering requirement is not severe, and therefore is not a disadvantage. For medium to higher power applications, where the input filter requirements dominate the size of the magnetics, the CCM boost is a good choice due to lower peak currents (which reduces conduction losses) and lower ripple current (which reduces filter requirements). The main tradeoff in using CRM boost is lower losses due to no reverse recovery in the boost diode vs higher ripple and peak currents.

10 Application and Implementation

NOTE

Information in the following applications sections is not part of the TI component specification, and TI does not warrant its accuracy or completeness. TI's customers are responsible for determining suitability of components for their purposes. Customers should validate and test their design implementation to confirm system functionality.

10.1 Application Information

The UCC3817A is a BiCMOS average current mode boost controller for high power factor, high efficiency preregulator power supplies. [Figure 5](#) shows the UCC3817A in a 250-W PFC preregulator circuit. Off-line switching power converters normally have an input current that is not sinusoidal. The input current waveform has a high harmonic content because current is drawn in pulses at the peaks of the input voltage waveform. An active power factor correction circuit programs the input current to follow the line voltage, forcing the converter to look like a resistive load to the line. A resistive load has 0° phase displacement between the current and voltage waveforms. Power factor can be defined in terms of the phase angle between two sinusoidal waveforms of the same frequency:

$$PF = \cos \Theta \quad (5)$$

Therefore, a purely resistive load would have a power factor of 1. In practice, power factors of 0.999 with THD (total harmonic distortion) of less than 3% are possible with a well-designed circuit. See the following guidelines for designing PFC boost converters using the UCC3817A.

NOTE

Schottky diodes, D5 and D6, are required to protect the PFC controller from electrical over stress during system power up.

10.2 Typical Application

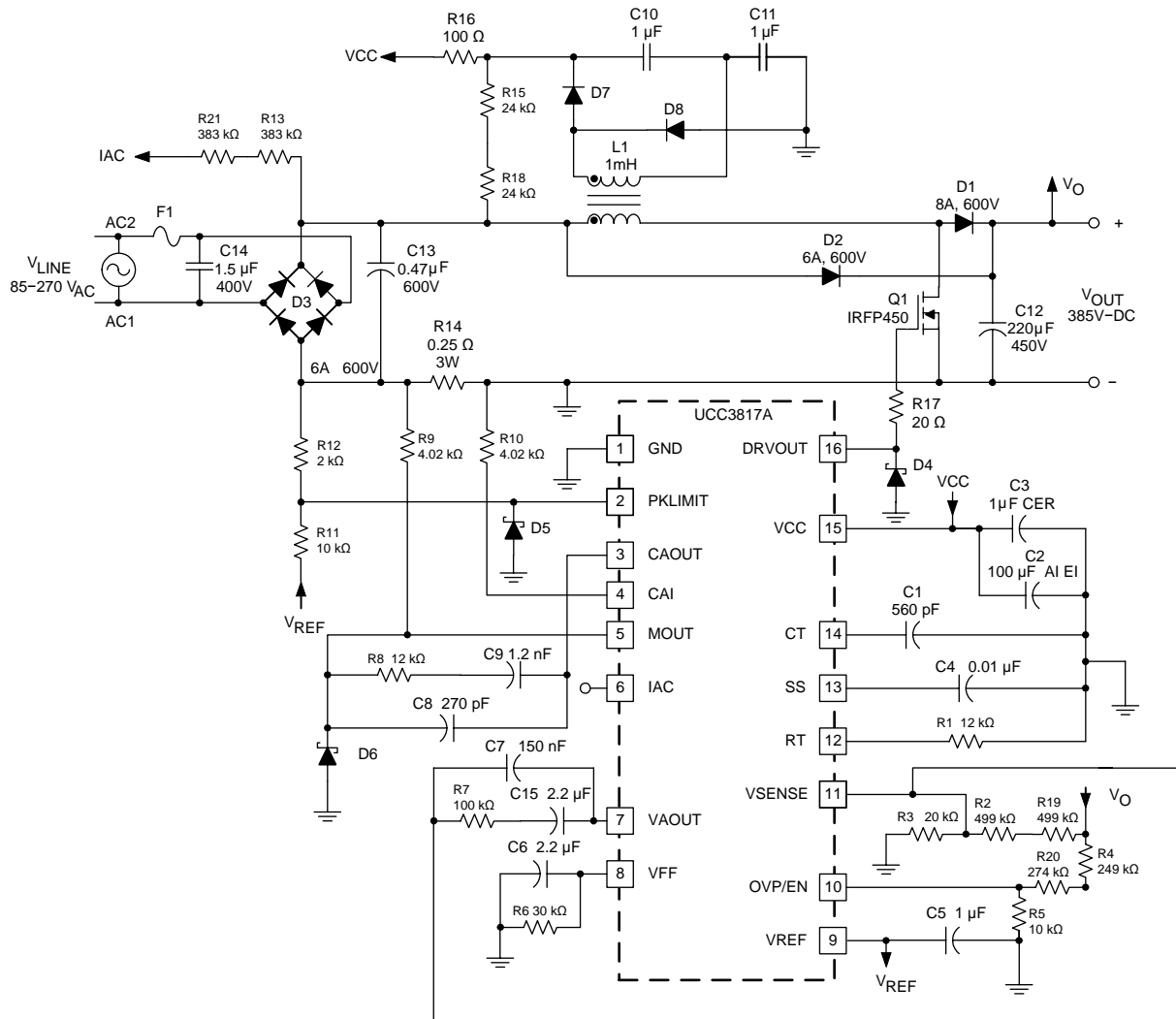

Copyright © 2016, Texas Instruments Incorporated

Figure 5. Typical Application Circuit

10.2.1 Design Requirements

Table 3 lists the parameters for this application.

Table 3. Design Parameters

PARAMETER	TEST CONDITIONS	MIN	TYP	MAX	UNIT
VIN	Input RMS voltage	85		270	V
	Input frequency		50/60		Hz
VOUT	Output Voltage		385	420	V
POUT	Output Power		250		W
	Holdup Time	All line and load conditions		16	ms
	Efficiency	Efficiency at 85 Vrms, 100% Load		91%	
	THD at Low Line	85 Vrms = 100% Load		5%	
	THD at High Line	265 Vrms, 100% Load		15%	

10.2.2 Detailed Design Procedure

10.2.2.1 Power Stage

10.2.2.1.1 LBOOST

The boost inductor value is determined by [Equation 6](#):

$$L_{\text{BOOST}} = \frac{(V_{\text{IN}(\text{min})} \times D)}{(\Delta I \times f_s)} \quad (6)$$

where D is the duty cycle, DI is the inductor ripple current and fS is the switching frequency. For the example circuit a switching frequency of 100 kHz, a ripple current of 875 mA, a maximum duty cycle of 0.688 and a minimum input voltage of 85 VRMS gives us a boost inductor value of about 1 mH. The values used in this equation are at the peak of low line, where the inductor current and its ripple are at a maximum.

10.2.2.1.2 C_{OUT}

Two main criteria, the capacitance and the voltage rating, dictate the selection of the output capacitor. The value of capacitance is determined by the holdup time required for supporting the load after input ac voltage is removed. Holdup is the amount of time that the output stays in regulation after the input has been removed. For this circuit, the desired holdup time is approximately 16 ms. Expressing the capacitor value in terms of output power, output voltage, and holdup time gives [Equation 7](#):

$$C_{\text{OUT}} = \frac{(2 \times P_{\text{OUT}} \times \Delta t)}{(V_{\text{OUT}}^2 - V_{\text{OUT}(\text{min})}^2)} \quad (7)$$

In practice, the calculated minimum capacitor value may be inadequate because output ripple voltage specifications limit the amount of allowable output capacitor ESR. Attaining a sufficiently low value of ESR often necessitates the use of a much larger capacitor value than calculated. The amount of output capacitor ESR allowed can be determined by dividing the maximum specified output ripple voltage by the inductor ripple current. In this design holdup time was the dominant determining factor and a 220-μF, 450-V capacitor was chosen for the output voltage level of 385 VDC at 250 W.

10.2.2.1.3 Power Switch Selection

As in any power supply design, tradeoffs between performance, cost and size have to be made. When selecting a power switch, it can be useful to calculate the total power dissipation in the switch for several different devices at the switching frequencies being considered for the converter. Total power dissipation in the switch is the sum of switching loss and conduction loss. Switching losses are the combination of the gate charge loss, C_{OSS} loss and turnon and turnoff losses, as shown in [Equation 8](#), [Equation 9](#), and [Equation 10](#).

$$P_{\text{GATE}} = Q_{\text{GATE}} \times V_{\text{GATE}} \times f_s \quad (8)$$

$$P_{\text{COSS}} = \frac{1}{2} \times C_{\text{OSS}} \times V_{\text{OFF}}^2 \times f_s \quad (9)$$

$$P_{\text{ON}} + P_{\text{OFF}} = \frac{1}{2} \times V_{\text{OFF}} \times I_L (t_{\text{ON}} + t_{\text{OFF}}) \times f_s$$

where

- Q_{GATE} is the total gate charge
- V_{GATE} is the gate drive voltage
- f_s is the clock frequency
- C_{OSS} is the drain source capacitance of the MOSFET
- I_L is the peak inductor current
- t_{ON} and t_{OFF} are the switching times (estimated using device parameters R_{GATE}
- Q_{GD} and V_{TH}) and V_{OFF} is the voltage across the switch during the off time, in this case V_{OFF} = V_{OUT} (10)

Conduction loss is calculated with [Equation 11](#) as the product of the R_{DS(on)} of the switch (at the worst case junction temperature) and the square of RMS current:

$$P_{COND} = R_{DS(on)} \times K \times I_{RMS}^2$$

where

- K is the temperature factor found in the manufacturer's $R_{DS(on)}$ vs. junction temperature curves (11)

Calculating these losses and plotting against frequency gives a curve that enables the designer to determine either which manufacturer's device has the best performance at the desired switching frequency, or which switching frequency has the least total loss for a particular power switch. For this design example an IRFP450 HEXFET from International Rectifier was chosen because of its low $R_{DS(on)}$ and its V_{DSS} rating. The IRFP450's $R_{DS(on)}$ of 0.4 Ω and the maximum V_{DSS} of 500 V made it an ideal choice. An excellent review of this procedure can be found in the Unitrode Power Supply Design Seminar SEM1200, Topic 6, Design Review: 140 W, [Multiple Output High Density DC/DC Converter].

10.2.2.2 Soft Start

The soft-start circuitry is used to prevent overshoot of the output voltage during start-up. This is accomplished by bringing up the voltage amplifier's output (V_{VAOUT}) slowly which allows for the PWM duty cycle to increase slowly. Use the following equation to select a capacitor for the soft-start pin.

In this example t_{DELAY} is equal to 7.5 ms, which would yield a C_{SS} of 10 nF.

$$C_{SS} = \frac{10\mu A \times t_{DELAY}}{7.5V} \quad (12)$$

In an open-loop test circuit, shorting the soft-start pin to ground does not ensure 0% duty cycle. This is due to the current amplifier's input offset voltage, which could force the current amplifier output high or low depending on the polarity of the offset voltage. However, in the typical application there is sufficient amount of inrush and bias current to overcome the current amplifier's offset voltage.

10.2.2.3 Multiplier

The output of the multiplier of the UCC3817A is a signal representing the desired input line current. It is an input to the current amplifier, which programs the current loop to control the input current to give high power factor operation. As such, the proper functioning of the multiplier is key to the success of the design. The inputs to the multiplier are VAOUT, the voltage amplifier error signal, I_{IAC}, a representation of the input rectified ac line voltage, and an input voltage feedforward signal, V_{VFF} . The output of the multiplier, I_{MOUT} , can be expressed as shown in Equation 13.

$$I_{MOUT} = I_{IAC} \times \frac{(V_{VAOUT} - 1)}{K \times V_{VFF}^2}$$

where

- K is a constant typically equal to 1 / V. (13)

The [Electrical Characteristics](#) table covers all the required operating conditions for designing with the multiplier. Additionally, curves in [Figure 14](#), [Figure 15](#), and [Figure 16](#) provide typical multiplier characteristics over its entire operating range.

The I_{IAC} signal is obtained through a high-value resistor connected between the rectified ac line and the IAC pin of the UCC3817A and UCC3818A. This resistor (R_{IAC}) is sized to give the maximum I_{IAC} current at high line. For the UCC3817A and UCC3818A the maximum I_{IAC} current is about 500 mA. A higher current than this can drive the multiplier out of its linear range. A smaller current level is functional, but noise can become an issue, especially at low input line. Assuming a universal line operation of 85 V_{RMS} to 265 V_{RMS} gives a R_{IAC} value of 750 k Ω . Because of voltage rating constraints of standard 1/4-W resistor, use a combination of lower value resistors connected in series to give the required resistance and distribute the high voltage amongst the resistors. For this design example two 383-k Ω resistors were used in series.

The current into the IAC pin is mirrored internally to the VFF pin where it is filtered to produce a voltage feed forward signal proportional to line voltage. The VFF voltage is used to keep the power stage gain constant; and to provide input power limiting. See Texas Instruments application note [Unitrode - UC3854A/B and UC3855A/B Provide Power Limiting With Sinusoidal Input Current for PFC Front Ends](#) (SLUA196) for a detailed explanation on how the VFF pin provides power limiting. Equation 14 can be used to size the VFF resistor (R_{VFF}) to provide power limiting where $V_{IN(min)}$ is the minimum RMS input voltage and R_{IAC} is the total resistance connected between the IAC pin and the rectified line voltage.

$$R_{VFF} = \frac{1.4 \text{ V}}{\frac{V_{IN(min)} \times 0.9}{2 \times R_{IAC}}} \approx 30 \text{ k}\Omega \quad (14)$$

Because the VFF voltage is generated from line voltage it needs to be adequately filtered to reduce total harmonic distortion caused by the 120 Hz rectified line voltage. Refer to the Unitrode Power Supply Design Seminar, *SEM-700 Topic 7, [Optimizing the Design of a High Power Factor Preregulator.]* A single pole filter was adequate for this design. Assuming that an allocation of 1.5% total harmonic distortion from this input is allowed, and that the second harmonic ripple is 66% of the input ac line voltage, the amount of attenuation required by this filter is:

$$\frac{1.5\%}{66\%} = 0.022 \quad (15)$$

With a ripple frequency (f_R) of 120 Hz and an attenuation of 0.022 requires that the pole of the filter (f_P) be placed at:

$$f_P = 120 \text{ Hz} \times 0.022 \approx 2.6 \text{ Hz} \quad (16)$$

Equation 17 can be used to select the filter capacitor (C_{VFF}) required to produce the desired low pass filter.

$$C_{VFF} = \frac{1}{2 \times \pi \times R_{VFF} \times f_P} \approx 2.2 \text{ }\mu\text{F} \quad (17)$$

The R_{MOUT} resistor is sized to match the maximum current through the sense resistor to the maximum multiplier current. The maximum multiplier current, or $I_{MOUT(max)}$, can be determined by Equation 18:

$$I_{MOUT(max)} = \frac{I_{IAC} @ V_{IN(min)} \times (V_{VAOUT(max)} - 1 \text{ V})}{K \times V_{VFF^2(min)}} \quad (18)$$

$I_{MOUT(max)}$ for this design is approximately 315 mA. The R_{MOUT} resistor can then be determined by Equation 19:

$$R_{MOUT} = \frac{V_{RSENSE}}{I_{MOUT(max)}} \quad (19)$$

In this example V_{RSENSE} was selected to give a dynamic operating range of 1.25 V, which gives an R_{MOUT} of roughly 3.91 k Ω .

10.2.2.4 Voltage Loop

The second major source of harmonic distortion is the ripple on the output capacitor at the second harmonic of the line frequency. This ripple is fed back through the error amplifier and appears as a 3rd harmonic ripple at the input to the multiplier. The voltage loop must be compensated not just for stability but also to attenuate the contribution of this ripple to the total harmonic distortion of the system (see Figure 6).

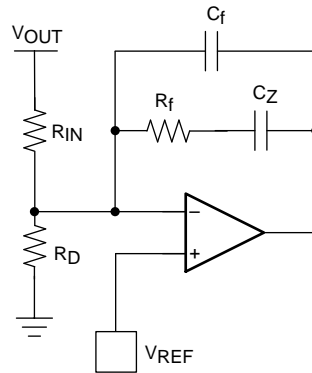

Figure 6. Voltage Amplifier Configuration

The gain of the voltage amplifier, G_{VA} , can be determined by first calculating the amount of ripple present on the output capacitor. The peak value of the second harmonic voltage is given by [Equation 20](#).

$$V_{OPK} = \frac{P_{IN}}{(2\pi \times f_R \times C_{OUT} \times V_{OUT})} \quad (20)$$

In this example V_{OPK} is equal to 3.91 V. Assuming an allowable contribution of 0.75% (1.5% peak to peak) from the voltage loop to the total harmonic distortion budget we set the gain equal to [Equation 21](#).

$$G_{VA} = \frac{(\Delta V_{VAOUT}) (0.015)}{2 \times V_{OPK}}$$

where

- ΔV_{VAOUT} is the effective output voltage range of the error amplifier (5 V for the UCC3817A). (21)

The network needed to realize this filter is comprised of an input resistor, R_{IN} , and feedback components C_f , C_z , and R_f . The value of R_{IN} is already determined because of its function as one half of a resistor divider from V_{OUT} feeding back to the voltage amplifier for output voltage regulation. In this case the value was chosen to be 1 M Ω . This high value was chosen to reduce power dissipation in the resistor. In practice, the resistor value would be realized by the use of two 500-k Ω resistors in series because of the voltage rating constraints of most standard 1/4-W resistors. The value of C_f is determined by [Equation 22](#).

$$C_f = \frac{1}{(2\pi \times f_R \times G_{VA} \times R_{IN})} \quad (22)$$

In this example C_f equals 150 nF. Resistor R_f sets the dc gain of the error amplifier and thus determines the frequency of the pole of the error amplifier. The location of the pole can be found by setting the gain of the loop equation to one and solving for the crossover frequency. The frequency, expressed in terms of input power, can be calculated by [Equation 23](#).

$$f_{VI}^2 = \frac{P_{IN}}{\left((2\pi)^2 \times \Delta V_{VAOUT} \times V_{OUT} \times R_{IN} \times C_{OUT} \times C_f \right)} \quad (23)$$

f_{VI} for this converter is 10 Hz. A derivation of this equation can be found in the Unitrode Power Supply Design Seminar SEM1000, Topic 1, [A 250-kHz, 500-W Power Factor Correction Circuit Employing Zero Voltage Transitions].

Solving for R_f becomes [Equation 24](#).

$$R_f = \frac{1}{(2\pi \times f_{VI} \times C_f)} \quad (24)$$

or R_f equals 100 k Ω .

Due to the low output impedance of the voltage amplifier, capacitor C_Z was added in series with R_F to reduce loading on the voltage divider. To ensure the voltage loop crossed over at f_{VI} , C_Z was selected to add a zero at a 10th of f_{VI} . For this design, a 2.2- μF capacitor was chosen for C_Z . Equation 25 can be used to calculate C_Z .

$$C_Z = \frac{1}{2 \times \pi \times \frac{f_{VI}}{10} \times R_f} \quad (25)$$

10.2.2.5 Current Loop

The gain of the power stage is calculated by Equation 26.

$$G_{ID}(s) = \frac{(V_{OUT} \times R_{SENSE})}{(s \times L_{BOOST} \times VP)} \quad (26)$$

R_{SENSE} has been chosen to give the desired differential voltage for the current sense amplifier at the desired current limit point. In this example, a current limit of 4 A and a reasonable differential voltage to the current amp of 1 V gives a R_{SENSE} value of 0.25 Ω . VP in Equation 26 is the voltage swing of the oscillator ramp, 4 V for the UCC3817A. Setting the crossover frequency of the system to 1/10th of the switching frequency, or 10 kHz, requires a power stage gain at that frequency of 0.383. For the system to have a gain of 1 at the crossover frequency, the current amplifier needs to have a gain of $1/G_{ID}$ at that frequency. G_{EA} , the current amplifier gain is then:

$$G_{EA} = \frac{1}{G_{ID}} = \frac{1}{0.383} = 2.611 \quad (27)$$

R_I is the R_{MOUT} resistor, previously calculated to be 3.9 k Ω . (see Figure 7). The gain of the current amplifier is R_f/R_I , so multiplying R_I by G_{EA} gives the value of R_f , in this case approximately 12 k Ω . Setting a zero at the crossover frequency and a pole at half the switching frequency completes the current loop compensation.

$$C_Z = \frac{1}{2 \times \pi \times R_f \times f_c} \quad (28)$$

$$C_P = \frac{1}{2 \times \pi \times R_f \times \frac{f_s}{2}} \quad (29)$$

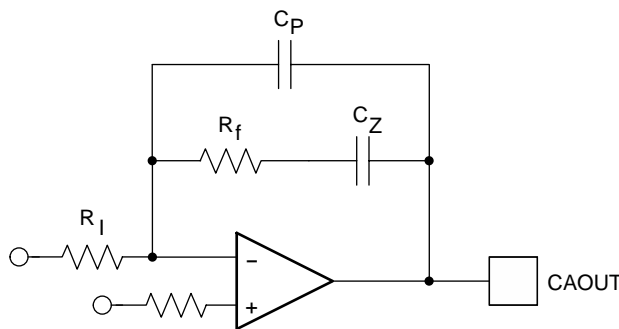

Figure 7. Current Loop Compensation

The UCC3817A current amplifier has the input from the multiplier applied to the inverting input. This change in architecture from previous Texas Instruments PFC controllers improves noise immunity in the current amplifier. It also adds a phase inversion into the control loop. The UCC3817A takes advantage of this phase inversion to implement leading-edge duty cycle modulation. Synchronizing a boost PFC controller to a downstream dc-to-dc controller reduces the ripple current seen by the bulk capacitor between stages, reducing capacitor size and cost and reducing EMI. This is explained in greater detail in the following section. The UCC3817A current amplifier configuration is shown in Figure 8.

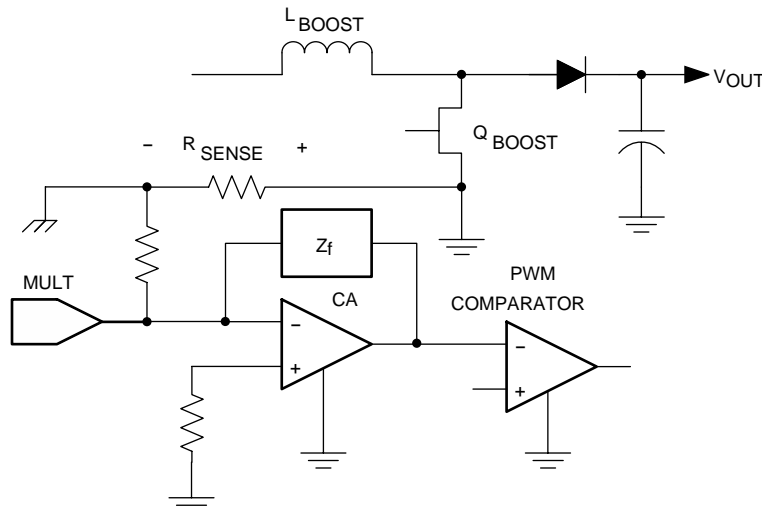

Figure 8. UCC3817A Current Amplifier Configuration

10.2.2.6 Start-Up

The UCC3818A version of the device is intended to have VCC connected to a 12-V supply voltage. The UCC3817A has an internal shunt regulator enabling the device to be powered from bootstrap circuitry as shown in the typical application circuit of Figure 5. The current drawn by the UCC3817A during undervoltage lockout, or start-up current, is typically 150 μ A. Once VCC is above the UVLO threshold, the device is enabled and draws 4 mA typically. A resistor connected between the rectified ac line voltage and the VCC pin provides current to the shunt regulator during power up. Once the circuit is operational, the bootstrap winding of the inductor provides the VCC voltage. Sizing of the start-up resistor is determined by the start-up time requirement of the system design.

$$I_C = C \frac{\Delta V}{\Delta t} \quad (30)$$

$$R = \frac{V_{RMS} \times (0.9)}{I_C}$$

where

- I_C is the charge current
 - C is the total capacitance at the VCC pin
 - ΔV is the UVLO threshold and Δt is the allowed start-up time
- (31)

Assuming a 1 second allowed start-up time, a 16-V UVLO threshold, and a total VCC capacitance of 100 μ F, a resistor value of 51 k Ω is required at a low line input voltage of 85 V_{RMS} . The IC start-up current is sufficiently small as to be ignored in sizing the start-up resistor.

10.2.2.7 Capacitor Ripple Reduction

For a power system where the PFC boost converter is followed by a dc-to-dc converter stage, there are benefits to synchronizing the two converters. In addition to the usual advantages such as noise reduction and stability, proper synchronization can significantly reduce the ripple currents in the boost circuit's output capacitor. Figure 9 helps illustrate the impact of proper synchronization by showing a PFC boost converter together with the simplified input stage of a forward converter. The capacitor current during a single switching cycle depends on the status of the switches Q1 and Q2 and is shown in Figure 10. It can be seen that with a synchronization scheme that maintains conventional trailing-edge modulation on both converters, the capacitor current ripple is highest. The greatest ripple current cancellation is attained when the overlap of Q1 off-time and Q2 on-time is maximized. One method of achieving this is to synchronize the turnon of the boost diode (D1) with the turnon of

Q2. This approach implies that the boost converter's leading edge is pulse width modulated while the forward converter is modulated with traditional trailing edge PWM. The UCC3817A is designed as a leading edge modulator with easy synchronization to the downstream converter to facilitate this advantage. Table 4 compares the $I_{CB(rms)}$ for D1/Q2 synchronization as offered by UCC3817A vs the $I_{CB(rms)}$ for the other extreme of synchronizing the turnon of Q1 and Q2 for a 200-W power system with a V_{BST} of 385 V.

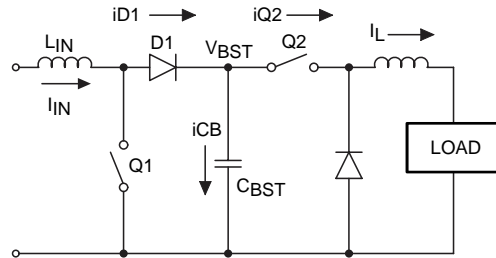

Figure 9. Simplified Representation of a 2-Stage PFC Power Supply

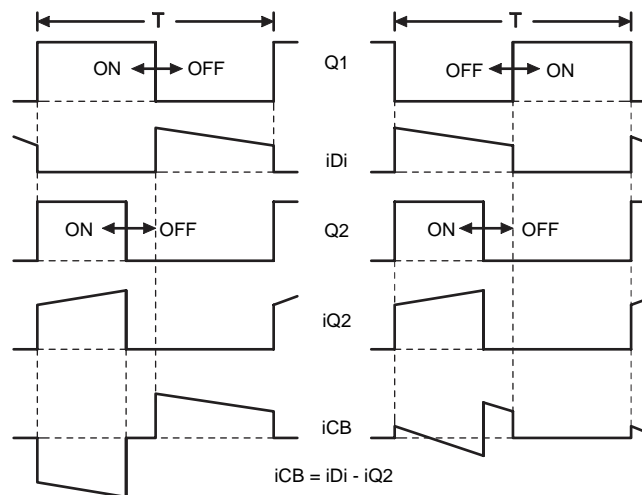

Figure 10. Timing Waveforms for Synchronization Scheme

Table 4 illustrates that the boost capacitor ripple current can be reduced by about 50% at nominal line and about 30% at high line with the synchronization scheme facilitated by the UCC3817A. Figure 11 shows the suggested technique for synchronizing the UCC3817A to the downstream converter. With this technique, maximum ripple reduction as shown in Figure 10 is achievable. The output capacitance value can be significantly reduced if its choice is dictated by ripple current or the capacitor life can be increased as a result. In cost sensitive designs where holdup time is not critical, this is a significant advantage.

Table 4. Effects of Synchronization on Boost Capacitor Current

D(Q2)	$V_{IN} = 85 \text{ V}$		$V_{IN} = 120 \text{ V}$		$V_{IN} = 240 \text{ V}$	
	Q1/Q2	D1/Q2	Q1/Q2	D1/Q2	Q1/Q2	D1/Q2
0.35	1.491 A	0.835 A	1.341 A	0.663 A	1.024 A	0.731 A
0.45	1.432A	0.93 A	1.276 A	0.664 A	0.897 A	0.614 A

An alternative method of synchronization to achieve the same ripple reduction is possible. In this method, the turnon of Q1 is synchronized to the turnoff of Q2. While this method yields almost identical ripple reduction and maintains trailing edge modulation on both converters, the synchronization is much more difficult to achieve and the circuit can become susceptible to noise as the synchronizing edge itself is being modulated.

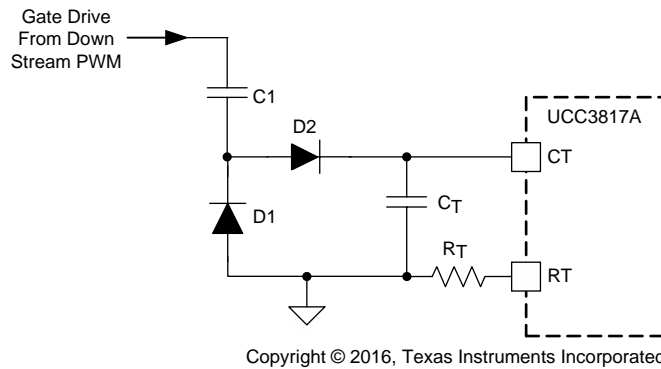
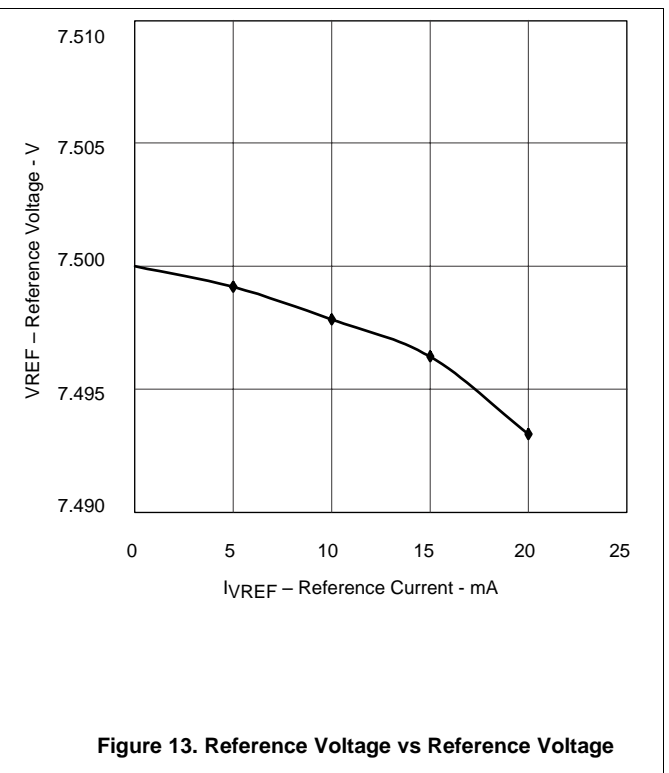
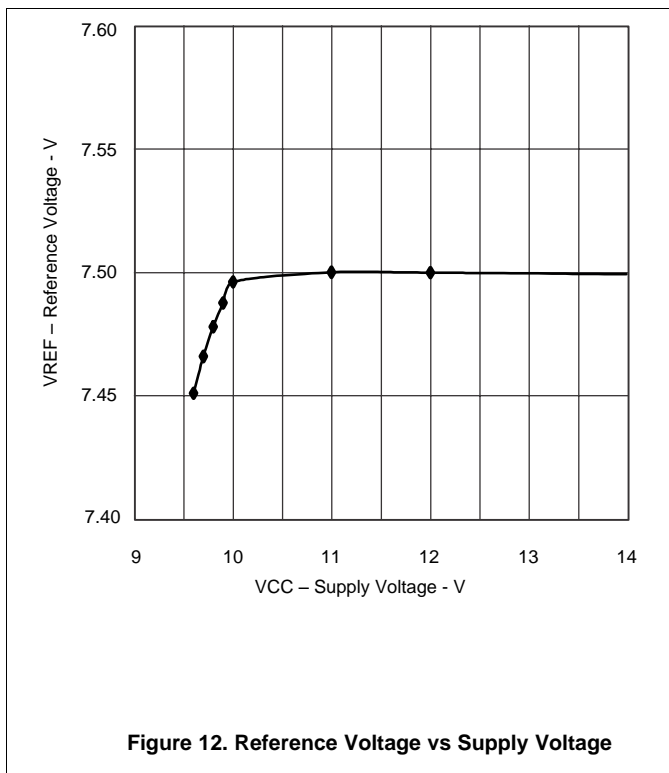

Figure 11. Synchronizing the UCC3817A to a Down-Stream Converter

10.2.3 Application Curves



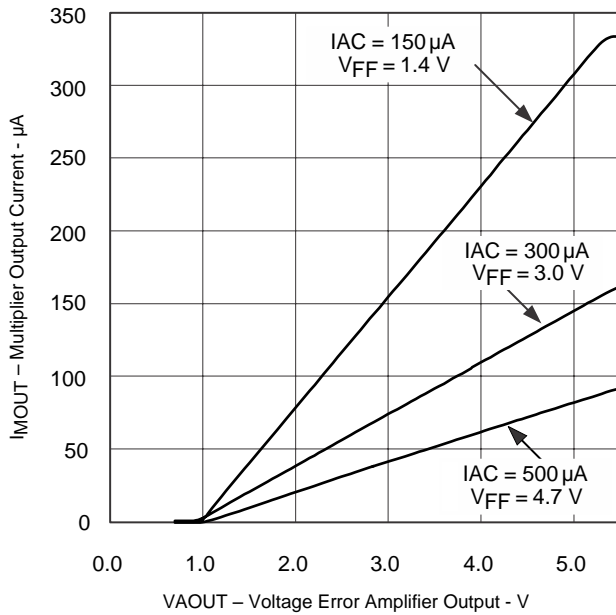

Figure 14. Multiplier Output Current vs Voltage Error Amplifier Output

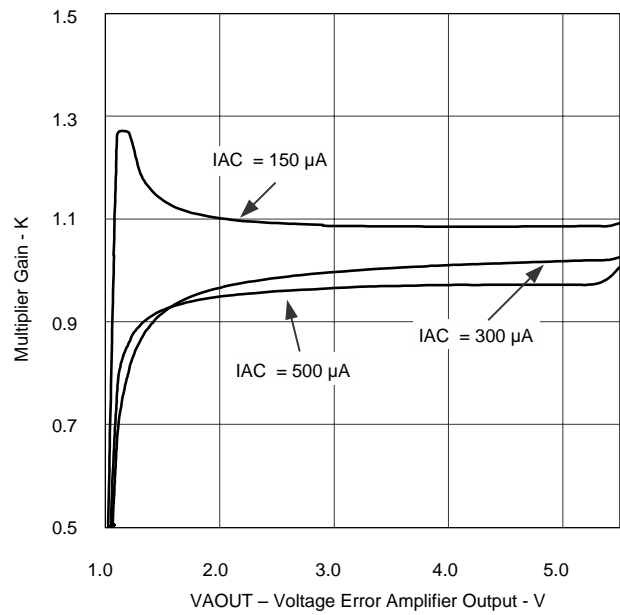

Figure 15. Multiplier Gain vs Voltage Error Amplifier Output

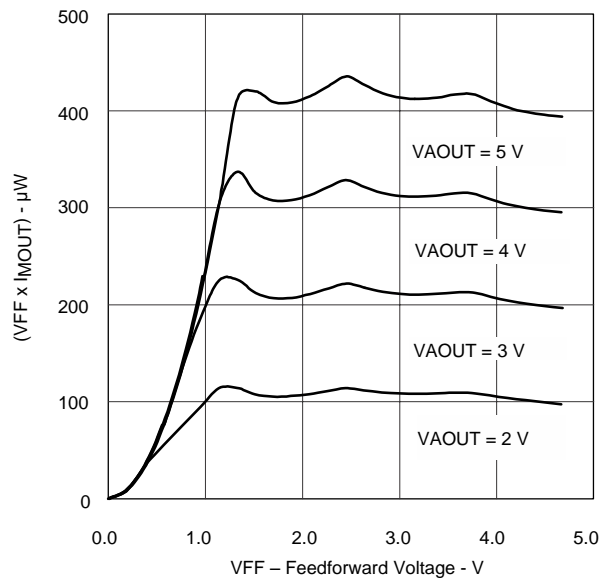

Figure 16. Multiplier Constant Power Performance

11 Power Supply Recommendations

The supply voltage for the device comes from VCC pin. This pin must be bypassed with a high-frequency capacitor (greater than 1 μF) and tied to GND. The UCC3817A and UCC2817A has a wide UVLO hysteresis of approximately 6.3 V that allows use of a lower value supply capacitor on this pin for quicker and easier start-up.

12 Layout

12.1 Layout Guidelines

12.1.1 Bias Current

The bias voltage is supplied either by an external dedicated DC-DC converter or by an auxiliary winding from the PFC inductor or the 2nd stage DC-DC converter.

The bias capacitor should be large enough to maintain sufficient voltage with AC line variations. Connect a 1- μF capacitor between VCC and GND as close to the IC as possible. For wide line voltages, an additional 18-V Zener clamp can also be used.

12.1.2 VREF

Connect a capacitor $\geq 0.1 \mu\text{F}$ between VREF and GND for stability.

12.2 Layout Example

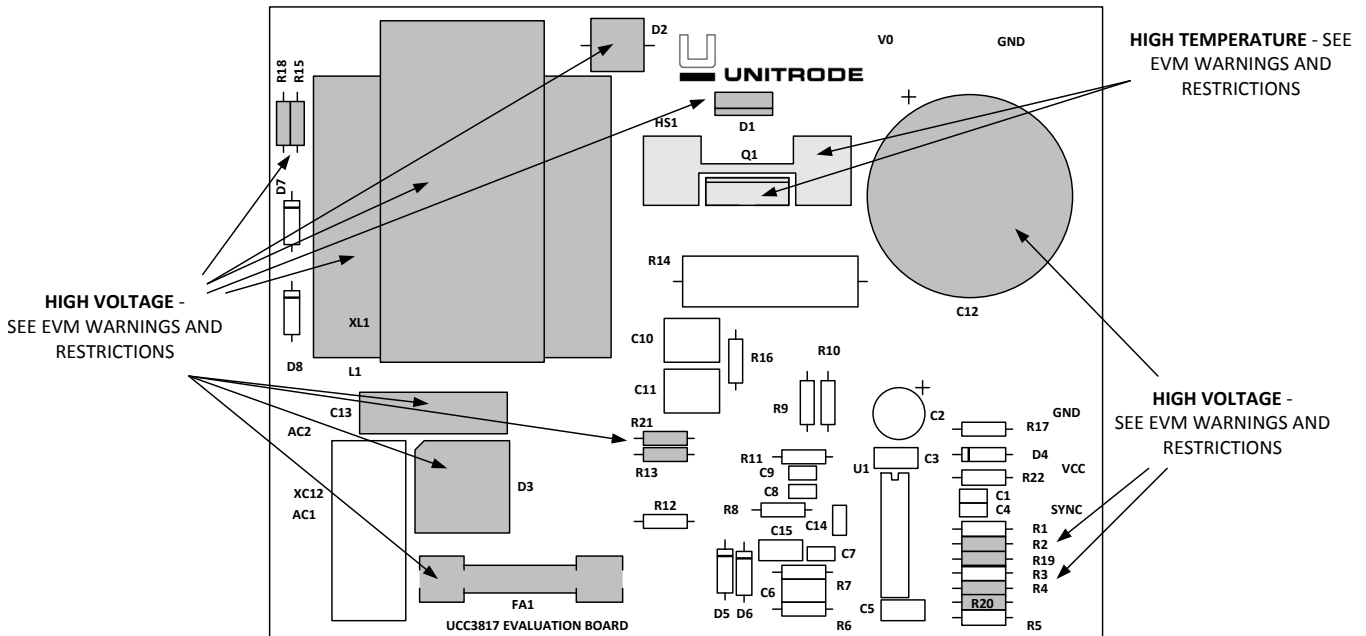

Figure 17. UCC3817EVM Evaluation Board Layout Assembly

13 デバイスおよびドキュメントのサポート

13.1 ドキュメントのサポート

13.1.1 関連資料

関連資料については、以下を参照してください。

- 『UCC3817A/18A/19AとUCC3817/18/19との相違点』(SLUA294)
- 『UCC3817 BICMOS力率プリレギュレータ評価ボード』(SLUU077)
- 『下流のコントローラ・ゲート・ドライブからのPFCコントローラの同期』(SLUA245)
- セミナー・トピック、「力率の高いスイッチング・プリレギュレータ設計の最適化」、L.H. Dixon、SEM-700、1990
- セミナー・トピック、「オフライン電源用の高力率プリレギュレータ」、L.H. Dixon、SEM-600、1988

13.2 関連リンク

次の表に、クイック・アクセス・リンクを示します。カテゴリには、技術資料、サポートおよびコミュニティ・リソース、ツールとソフトウェア、およびサンプル注文またはご購入へのクイック・アクセスが含まれます。

表 5. 関連リンク

製品	プロダクト・フォルダ	サンプルとご購入	技術資料	ツールとソフトウェア	サポートとコミュニティ
UCC2817A	ここをクリック	ここをクリック	ここをクリック	ここをクリック	ここをクリック
UCC2818A	ここをクリック	ここをクリック	ここをクリック	ここをクリック	ここをクリック
UCC3817A	ここをクリック	ここをクリック	ここをクリック	ここをクリック	ここをクリック
UCC3818A	ここをクリック	ここをクリック	ここをクリック	ここをクリック	ここをクリック

13.3 ドキュメントの更新通知を受け取る方法

ドキュメントの更新についての通知を受け取るには、ti.comのデバイス製品フォルダを開いてください。右上の隅にある「通知を受け取る」をクリックして登録すると、変更されたすべての製品情報に関するダイジェストを毎週受け取れます。変更の詳細については、修正されたドキュメントに含まれている改訂履歴をご覧ください。

13.4 コミュニティ・リソース

The following links connect to TI community resources. Linked contents are provided "AS IS" by the respective contributors. They do not constitute TI specifications and do not necessarily reflect TI's views; see TI's [Terms of Use](#).

TI E2E™ Online Community *TI's Engineer-to-Engineer (E2E) Community*. Created to foster collaboration among engineers. At e2e.ti.com, you can ask questions, share knowledge, explore ideas and help solve problems with fellow engineers.

Design Support *TI's Design Support* Quickly find helpful E2E forums along with design support tools and contact information for technical support.

13.5 商標

E2E is a trademark of Texas Instruments.
All other trademarks are the property of their respective owners.

13.6 静電気放電に関する注意事項



これらのデバイスは、限定的なESD (静電破壊) 保護機能を内蔵しています。保存時または取り扱い時は、MOSゲートに対する静電破壊を防止するために、リード線同士をショートさせておくか、デバイスを導電フォームに入れる必要があります。

13.7 Glossary

[SLYZ022](#) — *TI Glossary*.

This glossary lists and explains terms, acronyms, and definitions.

14 メカニカル、パッケージ、および注文情報

以降のページには、メカニカル、パッケージ、および注文に関する情報が記載されています。これらの情報は、指定のデバイスに対して提供されている最新のデータです。このデータは予告なく変更されることがあり、ドキュメントが改訂される場合もあります。本データシートのブラウザ版を使用されている場合は、画面左側の説明をご覧ください。

PACKAGING INFORMATION

Orderable part number	Status (1)	Material type (2)	Package Pins	Package qty Carrier	RoHS (3)	Lead finish/ Ball material (4)	MSL rating/ Peak reflow (5)	Op temp (°C)	Part marking (6)
UCC2817AD	NRND	Production	SOIC (D) 16	40 TUBE	Yes	NIPDAU	Level-1-260C-UNLIM	-40 to 85	UCC2817AD
UCC2817AD.A	NRND	Production	SOIC (D) 16	40 TUBE	Yes	NIPDAU	Level-1-260C-UNLIM	-40 to 85	UCC2817AD
UCC2817ADR	NRND	Production	SOIC (D) 16	2500 LARGE T&R	Yes	NIPDAU	Level-1-260C-UNLIM	-40 to 85	UCC2817AD
UCC2817ADR.A	NRND	Production	SOIC (D) 16	2500 LARGE T&R	Yes	NIPDAU	Level-1-260C-UNLIM	-40 to 85	UCC2817AD
UCC2817APW	NRND	Production	TSSOP (PW) 16	90 TUBE	Yes	NIPDAU	Level-2-260C-1 YEAR	-40 to 85	2817A
UCC2817APW.A	NRND	Production	TSSOP (PW) 16	90 TUBE	Yes	NIPDAU	Level-2-260C-1 YEAR	-40 to 85	2817A
UCC2817APWR	NRND	Production	TSSOP (PW) 16	2000 LARGE T&R	Yes	NIPDAU	Level-2-260C-1 YEAR	-40 to 85	2817A
UCC2817APWR.A	NRND	Production	TSSOP (PW) 16	2000 LARGE T&R	Yes	NIPDAU	Level-2-260C-1 YEAR	-40 to 85	2817A
UCC2818AD	NRND	Production	SOIC (D) 16	40 TUBE	Yes	NIPDAU	Level-1-260C-UNLIM	-40 to 85	UCC2818AD
UCC2818AD.A	NRND	Production	SOIC (D) 16	40 TUBE	Yes	NIPDAU	Level-1-260C-UNLIM	-40 to 85	UCC2818AD
UCC2818ADR	NRND	Production	SOIC (D) 16	2500 LARGE T&R	Yes	NIPDAU	Level-1-260C-UNLIM	-40 to 85	UCC2818AD
UCC2818ADR.A	NRND	Production	SOIC (D) 16	2500 LARGE T&R	Yes	NIPDAU	Level-1-260C-UNLIM	-40 to 85	UCC2818AD
UCC2818AN	Active	Production	PDIP (N) 16	25 TUBE	Yes	NIPDAU	N/A for Pkg Type	-40 to 85	UCC2818AN
UCC2818AN.A	Active	Production	PDIP (N) 16	25 TUBE	Yes	NIPDAU	N/A for Pkg Type	-40 to 85	UCC2818AN
UCC2818APW	Active	Production	TSSOP (PW) 16	90 TUBE	Yes	NIPDAU	Level-2-260C-1 YEAR	-40 to 85	2818A
UCC2818APW.A	Active	Production	TSSOP (PW) 16	90 TUBE	Yes	NIPDAU	Level-2-260C-1 YEAR	-40 to 85	2818A
UCC2818APWR	NRND	Production	TSSOP (PW) 16	2000 LARGE T&R	Yes	NIPDAU	Level-2-260C-1 YEAR	-40 to 85	2818A
UCC2818APWR.A	NRND	Production	TSSOP (PW) 16	2000 LARGE T&R	Yes	NIPDAU	Level-2-260C-1 YEAR	-40 to 85	2818A
UCC2818APWRG4	NRND	Production	TSSOP (PW) 16	2000 LARGE T&R	Yes	NIPDAU	Level-2-260C-1 YEAR	-40 to 85	2818A
UCC3817AD	Active	Production	SOIC (D) 16	40 TUBE	Yes	NIPDAU	Level-1-260C-UNLIM	0 to 70	UCC3817AD
UCC3817AD.A	Active	Production	SOIC (D) 16	40 TUBE	Yes	NIPDAU	Level-1-260C-UNLIM	0 to 70	UCC3817AD
UCC3818AD	Active	Production	SOIC (D) 16	40 TUBE	Yes	NIPDAU	Level-1-260C-UNLIM	0 to 70	UCC3818AD
UCC3818AD.A	Active	Production	SOIC (D) 16	40 TUBE	Yes	NIPDAU	Level-1-260C-UNLIM	0 to 70	UCC3818AD
UCC3818ADR	NRND	Production	SOIC (D) 16	2500 LARGE T&R	Yes	NIPDAU	Level-1-260C-UNLIM	0 to 70	UCC3818AD
UCC3818ADR.A	NRND	Production	SOIC (D) 16	2500 LARGE T&R	Yes	NIPDAU	Level-1-260C-UNLIM	0 to 70	UCC3818AD
UCC3818AN	NRND	Production	PDIP (N) 16	25 TUBE	Yes	NIPDAU	N/A for Pkg Type	0 to 70	UCC3818AN
UCC3818AN.A	NRND	Production	PDIP (N) 16	25 TUBE	Yes	NIPDAU	N/A for Pkg Type	0 to 70	UCC3818AN
UCC3818APW	NRND	Production	TSSOP (PW) 16	90 TUBE	Yes	NIPDAU	Level-2-260C-1 YEAR	0 to 70	3818A
UCC3818APW.A	NRND	Production	TSSOP (PW) 16	90 TUBE	Yes	NIPDAU	Level-2-260C-1 YEAR	0 to 70	3818A

Orderable part number	Status (1)	Material type (2)	Package Pins	Package qty Carrier	RoHS (3)	Lead finish/ Ball material (4)	MSL rating/ Peak reflow (5)	Op temp (°C)	Part marking (6)
UCC3818APWR	NRND	Production	TSSOP (PW) 16	2000 LARGE T&R	Yes	NIPDAU	Level-2-260C-1 YEAR	0 to 70	3818A
UCC3818APWR.A	NRND	Production	TSSOP (PW) 16	2000 LARGE T&R	Yes	NIPDAU	Level-2-260C-1 YEAR	0 to 70	3818A

(1) Status: For more details on status, see our [product life cycle](#).

(2) Material type: When designated, preproduction parts are prototypes/experimental devices, and are not yet approved or released for full production. Testing and final process, including without limitation quality assurance, reliability performance testing, and/or process qualification, may not yet be complete, and this item is subject to further changes or possible discontinuation. If available for ordering, purchases will be subject to an additional waiver at checkout, and are intended for early internal evaluation purposes only. These items are sold without warranties of any kind.

(3) RoHS values: Yes, No, RoHS Exempt. See the [TI RoHS Statement](#) for additional information and value definition.

(4) Lead finish/Ball material: Parts may have multiple material finish options. Finish options are separated by a vertical ruled line. Lead finish/Ball material values may wrap to two lines if the finish value exceeds the maximum column width.

(5) MSL rating/Peak reflow: The moisture sensitivity level ratings and peak solder (reflow) temperatures. In the event that a part has multiple moisture sensitivity ratings, only the lowest level per JEDEC standards is shown. Refer to the shipping label for the actual reflow temperature that will be used to mount the part to the printed circuit board.

(6) Part marking: There may be an additional marking, which relates to the logo, the lot trace code information, or the environmental category of the part.

Multiple part markings will be inside parentheses. Only one part marking contained in parentheses and separated by a "-" will appear on a part. If a line is indented then it is a continuation of the previous line and the two combined represent the entire part marking for that device.

Important Information and Disclaimer: The information provided on this page represents TI's knowledge and belief as of the date that it is provided. TI bases its knowledge and belief on information provided by third parties, and makes no representation or warranty as to the accuracy of such information. Efforts are underway to better integrate information from third parties. TI has taken and continues to take reasonable steps to provide representative and accurate information but may not have conducted destructive testing or chemical analysis on incoming materials and chemicals. TI and TI suppliers consider certain information to be proprietary, and thus CAS numbers and other limited information may not be available for release.

In no event shall TI's liability arising out of such information exceed the total purchase price of the TI part(s) at issue in this document sold by TI to Customer on an annual basis.

OTHER QUALIFIED VERSIONS OF UCC2818A :

- Automotive : [UCC2818A-Q1](#)

NOTE: Qualified Version Definitions:

- Automotive - Q100 devices qualified for high-reliability automotive applications targeting zero defects

TAPE AND REEL INFORMATION

QUADRANT ASSIGNMENTS FOR PIN 1 ORIENTATION IN TAPE



*All dimensions are nominal

Device	Package Type	Package Drawing	Pins	SPQ	Reel Diameter (mm)	Reel Width W1 (mm)	A0 (mm)	B0 (mm)	K0 (mm)	P1 (mm)	W (mm)	Pin1 Quadrant
UCC2817ADR	SOIC	D	16	2500	330.0	16.4	6.5	10.3	2.1	8.0	16.0	Q1
UCC2817APWR	TSSOP	PW	16	2000	330.0	12.4	6.9	5.6	1.6	8.0	12.0	Q1
UCC2818ADR	SOIC	D	16	2500	330.0	16.4	6.5	10.3	2.1	8.0	16.0	Q1
UCC2818APWR	TSSOP	PW	16	2000	330.0	12.4	6.9	5.6	1.6	8.0	12.0	Q1
UCC3818ADR	SOIC	D	16	2500	330.0	16.4	6.5	10.3	2.1	8.0	16.0	Q1
UCC3818APWR	TSSOP	PW	16	2000	330.0	12.4	6.9	5.6	1.6	8.0	12.0	Q1

TAPE AND REEL BOX DIMENSIONS

*All dimensions are nominal

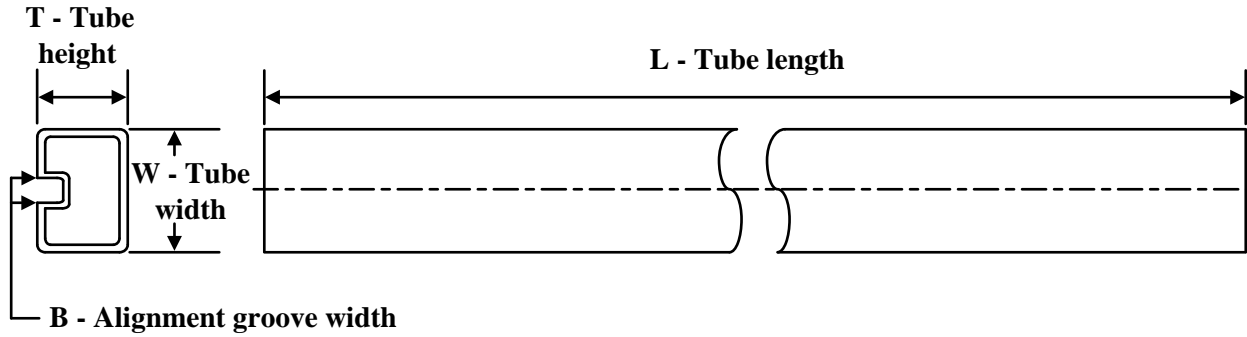
Device	Package Type	Package Drawing	Pins	SPQ	Length (mm)	Width (mm)	Height (mm)
UCC2817ADR	SOIC	D	16	2500	340.5	336.1	32.0
UCC2817APWR	TSSOP	PW	16	2000	353.0	353.0	32.0
UCC2818ADR	SOIC	D	16	2500	353.0	353.0	32.0
UCC2818APWR	TSSOP	PW	16	2000	353.0	353.0	32.0
UCC3818ADR	SOIC	D	16	2500	353.0	353.0	32.0
UCC3818APWR	TSSOP	PW	16	2000	353.0	353.0	32.0

TUBE

*All dimensions are nominal



Device	Package Name	Package Type	Pins	SPQ	L (mm)	W (mm)	T (μm)	B (mm)
UCC2817AD	D	SOIC	16	40	507	8	3940	4.32
UCC2817AD.A	D	SOIC	16	40	507	8	3940	4.32
UCC2817APW	PW	TSSOP	16	90	508	8.5	3250	2.8
UCC2817APW.A	PW	TSSOP	16	90	508	8.5	3250	2.8
UCC2818AD	D	SOIC	16	40	507	8	3940	4.32
UCC2818AD.A	D	SOIC	16	40	507	8	3940	4.32
UCC2818AN	N	PDIP	16	25	506	13.97	11230	4.32
UCC2818AN.A	N	PDIP	16	25	506	13.97	11230	4.32
UCC2818APW	PW	TSSOP	16	90	508	8.5	3250	2.8
UCC2818APW.A	PW	TSSOP	16	90	508	8.5	3250	2.8
UCC3817AD	D	SOIC	16	40	507	8	3940	4.32
UCC3817AD.A	D	SOIC	16	40	507	8	3940	4.32
UCC3818AD	D	SOIC	16	40	507	8	3940	4.32
UCC3818AD.A	D	SOIC	16	40	507	8	3940	4.32
UCC3818AN	N	PDIP	16	25	506	13.97	11230	4.32
UCC3818AN.A	N	PDIP	16	25	506	13.97	11230	4.32
UCC3818APW	PW	TSSOP	16	90	508	8.5	3250	2.8
UCC3818APW.A	PW	TSSOP	16	90	508	8.5	3250	2.8

D (R-PDSO-G16)

PLASTIC SMALL OUTLINE



4040047-6/M 06/11

- NOTES:
- A. All linear dimensions are in inches (millimeters).
 - B. This drawing is subject to change without notice.
 -  C. Body length does not include mold flash, protrusions, or gate burrs. Mold flash, protrusions, or gate burrs shall not exceed 0.006 (0,15) each side.
 -  D. Body width does not include interlead flash. Interlead flash shall not exceed 0.017 (0,43) each side.
 - E. Reference JEDEC MS-012 variation AC.



4220204/B 12/2023

NOTES:

1. All linear dimensions are in millimeters. Any dimensions in parenthesis are for reference only. Dimensioning and tolerancing per ASME Y14.5M.
2. This drawing is subject to change without notice.
3. This dimension does not include mold flash, protrusions, or gate burrs. Mold flash, protrusions, or gate burrs shall not exceed 0.15 mm per side.
4. This dimension does not include interlead flash. Interlead flash shall not exceed 0.25 mm per side.
5. Reference JEDEC registration MO-153.

EXAMPLE BOARD LAYOUT

PW0016A

TSSOP - 1.2 mm max height

SMALL OUTLINE PACKAGE



LAND PATTERN EXAMPLE
EXPOSED METAL SHOWN
SCALE: 10X



SOLDER MASK DETAILS

4220204/B 12/2023

NOTES: (continued)

- 6. Publication IPC-7351 may have alternate designs.
- 7. Solder mask tolerances between and around signal pads can vary based on board fabrication site.

EXAMPLE STENCIL DESIGN

PW0016A

TSSOP - 1.2 mm max height

SMALL OUTLINE PACKAGE



SOLDER PASTE EXAMPLE
BASED ON 0.125 mm THICK STENCIL
SCALE: 10X

4220204/B 12/2023

NOTES: (continued)

8. Laser cutting apertures with trapezoidal walls and rounded corners may offer better paste release. IPC-7525 may have alternate design recommendations.
9. Board assembly site may have different recommendations for stencil design.

N (R-PDIP-T**)

PLASTIC DUAL-IN-LINE PACKAGE

16 PINS SHOWN



4040049/E 12/2002

- NOTES:
- A. All linear dimensions are in inches (millimeters).
 - B. This drawing is subject to change without notice.
 - (C) Falls within JEDEC MS-001, except 18 and 20 pin minimum body length (Dim A).
 - (D) The 20 pin end lead shoulder width is a vendor option, either half or full width.

重要なお知らせと免責事項

TI は、技術データと信頼性データ (データシートを含みます)、設計リソース (リファレンス デザインを含みます)、アプリケーションや設計に関する各種アドバイス、Web ツール、安全性情報、その他のリソースを、欠陥が存在する可能性のある「現状のまま」提供しており、商品性および特定目的に対する適合性の黙示保証、第三者の知的財産権の非侵害保証を含むいかなる保証も、明示的または黙示的にかかわらず拒否します。

これらのリソースは、TI 製品を使用する設計の経験を積んだ開発者への提供を意図したものです。(1) お客様のアプリケーションに適した TI 製品の選定、(2) お客様のアプリケーションの設計、検証、試験、(3) お客様のアプリケーションに該当する各種規格や、その他のあらゆる安全性、セキュリティ、規制、または他の要件への確実な適合に関する責任を、お客様のみが単独で負うものとし、

上記の各種リソースは、予告なく変更される可能性があります。これらのリソースは、リソースで説明されている TI 製品を使用するアプリケーションの開発の目的でのみ、TI はその使用をお客様に許諾します。これらのリソースに関して、他の目的で複製することや掲載することは禁止されています。TI や第三者の知的財産権のライセンスが付与されている訳ではありません。お客様は、これらのリソースを自身で使用した結果発生するあらゆる申し立て、損害、費用、損失、責任について、TI およびその代理人を完全に補償するものとし、TI は一切の責任を拒否します。

TI の製品は、[TI の販売条件](#)、[TI の総合的な品質ガイドライン](#)、[ti.com](#) または TI 製品などに関連して提供される他の適用条件に従い提供されます。TI がこれらのリソースを提供することは、適用される TI の保証または他の保証の放棄の拡大や変更を意味するものではありません。TI がカスタム、またはカスタマー仕様として明示的に指定していない限り、TI の製品は標準的なカタログに掲載される汎用機器です。

お客様がいかなる追加条項または代替条項を提案する場合も、TI はそれらに異議を唱え、拒否します。

Copyright © 2026, Texas Instruments Incorporated

最終更新日 : 2025 年 10 月