

UCC5350-Q1

SiC/IGBT および車載アプリケーション向けシングル・チャンネル絶縁型ゲート・ドライバ

1 特長

- 5kV_{RMS} および 3kV_{RMS} シングル チャンネル絶縁型ゲートドライバ
- 車載アプリケーション向けに AEC-Q100 認証済み
 - 温度グレード 1
 - HBM ESD 分類レベル H2
 - CDM ESD 分類レベル C6
- 機能オプション
 - 分割出力、8V UVLO (UCC5350SB-Q1)
 - ミラー クランプ、12V UVLO (UCC5350MC-Q1)
- ±5A 以上のピーク電流駆動力
- 入力電圧範囲: 3V~15V
- 最大 33V のドライバ電源電圧
 - 8V および 12V UVLO オプション
- 最小 CMTI: 100V/ns
- 負の 5V に対応可能な入力ピン
- 伝搬遅延時間: 100ns 以下、部品間スキュー: <25ns
- 8 ピン DWV (浴面距離 8.5mm) および D (浴面距離 4mm) パッケージ
- 絶縁バリアの寿命: >40 年
- 安全関連認証:
 - UL 1577 に準拠した絶縁耐圧定格 (1 分間):
5000V_{RMS} (DWV)、
3000V_{RMS} (D)
- CMOS 入力
- 動作時接合部温度: -40°C~+150°C

2 アプリケーション

- オンボード チャージャ
- EV 用トラクション インバータ
- DC 充電ステーション
- HVAC
- 暖房器具

3 概要

UCC5350-Q1 はシングル チャンネルの絶縁ゲートドライバで、5A ソースおよび 5A シンクの最小ピーク電流を持ち、MOSFET、IGBT、SiC MOSFET を駆動するよう設計されています。UCC5350-Q1 には、ミラー クランプまたは分割出力のオプションがあります。CLAMP ピンを使ってトランジスタのゲートを内部 FET と出力に接続することで、ミラー電流による誤ターンオンを防止できます。分割出力付きの製品を使うと、ゲート電圧の立ち上がり / 立ち下がり時間を OUTH および OUTL ピンで個別に制御できます。

製品情報

部品のバージョン	特長	パッケージ ⁽¹⁾	本体サイズ (公称)
UCC5350MC-Q1	ミラー クランプ、 12V UVLO	DWV SOIC-8	7.5mm × 5.85mm
		D SOIC-8	3.91mm × 4.9mm
UCC5350SB-Q1	分割出力、8V UVLO	D SOIC-8	3.91mm × 4.9mm

(1) 供給されているすべてのパッケージについては、[セクション 14](#) を参照してください。

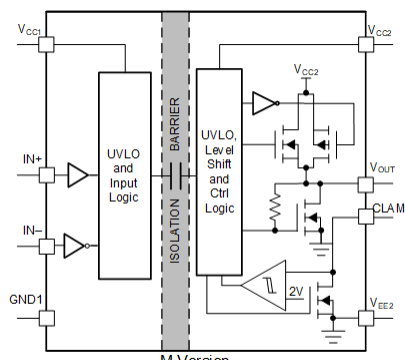
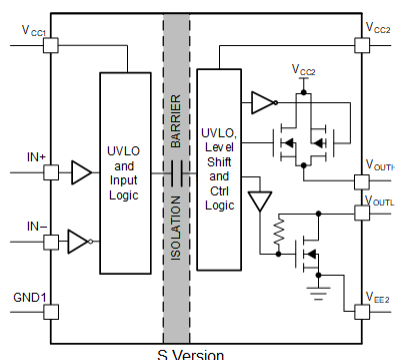

Copyright © 2018, Texas Instruments Incorporated

機能ブロック図 (S、M バージョン)



Table of Contents

1 特長	1	8.1 Overview.....	18
2 アプリケーション	1	8.2 Functional Block Diagram.....	18
3 概要	1	8.3 Feature Description.....	19
4 概要 (続き)	3	8.4 Device Functional Modes.....	23
5 Pin Configuration and Function	4	9 Application and Implementation	25
6 Specifications	5	9.1 Application Information.....	25
6.1 Absolute Maximum Ratings.....	5	9.2 Typical Application.....	25
6.2 ESD Ratings.....	5	10 Power Supply Recommendations	31
6.3 Recommended Operating Conditions.....	5	11 Layout	31
6.4 Thermal Information.....	5	11.1 Layout Guidelines.....	31
6.5 Power Ratings.....	6	11.2 Layout Example.....	32
6.6 Insulation Specifications for D Package.....	6	11.3 PCB Material.....	34
6.7 Insulation Specifications for DWV Package.....	8	12 Device and Documentation Support	35
6.8 Safety-Related Certifications For D Package.....	9	12.1 Device Support.....	35
6.9 Safety-Related Certifications For DWV Package.....	9	12.2 Documentation Support.....	35
6.10 Safety Limiting Values.....	9	12.3 Certifications.....	35
6.11 Electrical Characteristics.....	10	12.4 ドキュメントの更新通知を受け取る方法.....	35
6.12 Switching Characteristics.....	11	12.5 サポート・リソース.....	35
6.13 Insulation Characteristics Curves.....	12	12.6 Trademarks.....	35
6.14 Typical Characteristics.....	13	12.7 静電気放電に関する注意事項.....	35
7 Parameter Measurement Information	16	12.8 用語集.....	35
7.1 Propagation Delay, Inverting, and Noninverting Configuration.....	16	13 Revision History	36
8 Detailed Description	18	14 Mechanical, Packaging, and Orderable Information	36

4 概要 (続き)

UCC5350-Q1 は、4mm SOIC-8 (D) または 8.5mm ワイド ボディ SOIC-8 (DWV) パッケージで供給され、それぞれ最大 $3kV_{RMS}$ および $5kV_{RMS}$ の絶縁電圧をサポートできます。入力側は、絶縁バリア寿命が 40 年以上ある SiO₂ 容量性絶縁技術によって出力側と絶縁されています。UCC5350-Q1 は、高電圧トラクション インバータおよびオンボード チャージャなどの用途の IGBT または MOSFET の駆動に適しています。

フォトカプラと比較して、UCC5350-Q1 デバイスは部品間スキューが小さく、伝搬遅延時間が短く、より高い温度でも動作し、CMTI が高いという特長があります。

5 Pin Configuration and Function



図 5-1. UCC5350MC-Q1 8-Pin SOIC Top View



図 5-2. UCC5350SB-Q1 8-Pin SOIC Top View

表 5-1. Pin Functions

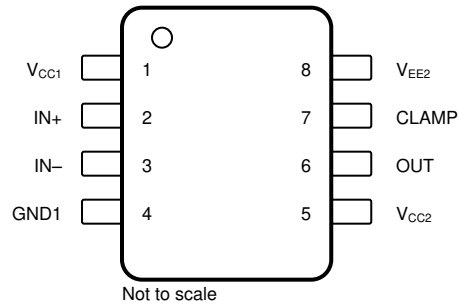
NAME	PIN		TYPE ⁽¹⁾	DESCRIPTION
	NO. UCC5350MC-Q1	NO. UCC5350SB-Q1		
CLAMP	7	—	I	Active Miller-clamp input used to prevent false turn-on of the power switches found on the 'M' version.
GND1	4	4	G	Input ground. All signals on the input side are referenced to this ground.
IN+	2	2	I	Noninverting gate-drive voltage-control input. The IN+ pin has a CMOS input threshold. This pin is pulled low internally if left open. Use 表 8-4 to understand the input and output logic of these devices.
IN-	3	3	I	Inverting gate-drive voltage control input. The IN- pin has a CMOS input threshold. This pin is pulled high internally if left open. Use 表 8-4 to understand the input and output logic of these devices.
OUT	6	—	O	Gate-drive output found on the 'M' version
OUTH	—	6	O	Gate-drive pullup output found on the 'S' version
OUTL	—	7	O	Gate-drive pulldown output found on the 'S' version
V _{CC1}	1	1	P	Input supply voltage. Connect a locally decoupled capacitor to GND1. Use a low-ESR or ESL capacitor located as close to the device as possible.
V _{CC2}	5	5	P	Positive output supply rail. Connect a locally decoupled capacitor to V _{EE2} . Use a low-ESR or ESL capacitor located as close to the device as possible.
V _{EE2}	8	8	G	Ground pin. Connect to MOSFET source or IGBT emitter. Connect a locally decoupled capacitor from V _{CC2} to V _{EE2} . Use a low-ESR or ESL capacitor located as close to the device as possible.

(1) P = Power, G = Ground, I = Input, O = Output

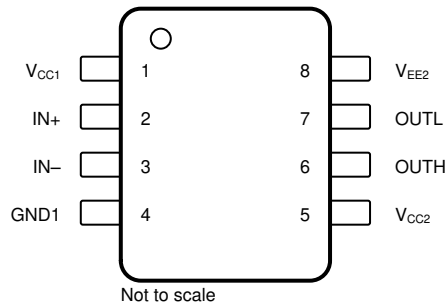
6 Specifications

6.1 Absolute Maximum Ratings

Over operating free air temperature range (unless otherwise noted)⁽¹⁾

		MIN	MAX	UNIT
Input bias pin supply voltage	$V_{CC1} - GND1$	$GND1 - 0.3$	18	V
Driver bias supply	$V_{CC2} - V_{EE2}$	-0.3	35	V
Output signal voltage	$V_{OUTH} - V_{EE2}, V_{OUTL} - V_{EE2}, V_{OUT} - V_{EE2}, V_{CLAMP} - V_{EE2}$	$V_{EE2} - 0.3$	$V_{CC2} + 0.3$	V
Input signal voltage	$V_{IN+} - GND1, V_{IN-} - GND1$	$GND1 - 5$	$V_{CC1} + 0.3$	V
Junction temperature, T_J ⁽²⁾		-40	150	°C
Storage temperature, T_{stg}		-65	150	°C

- (1) Operation outside the Absolute Maximum Ratings may cause permanent device damage. Absolute Maximum Ratings do not imply functional operation of the device at these or any other conditions beyond those listed under Recommended Operating Conditions. If outside the Recommended Operating Conditions but within the Absolute Maximum Ratings, the device may not be fully functional, and this may affect device reliability, functionality, performance, and shorten the device lifetime.
- (2) To maintain the recommended operating conditions for T_J , see the Thermal Information table.

6.2 ESD Ratings

		VALUE	UNIT
$V_{(ESD)}$	Electrostatic discharge	Human-body model (HBM), per AEC Q100-002 ⁽¹⁾	±4000
		Charged-device model (CDM), per AEC Q100-011	±1500

- (1) AEC Q100-002 indicates that HBM stressing shall be in accordance with the ANSI/ESDA/JEDEC JS-001 specification.

6.3 Recommended Operating Conditions

Over operating free-air temperature range (unless otherwise noted)

		MIN	NOM	MAX	UNIT
V_{CC1}	Supply voltage, input side	3		15	V
V_{CC2}	Positive supply voltage output side ($V_{CC2} - V_{EE2}$), UCC5350MC	13.2		33	V
V_{CC2}	Positive supply voltage output side ($V_{CC2} - V_{EE2}$), UCC5350SB	9.5		33	V
T_J	Junction Temperature	-40		150	°C

6.4 Thermal Information

THERMAL METRIC ⁽¹⁾		UCC5350-Q1		UNIT
		D	DWV	
		8 PINS	8 PINS	
$R_{\theta JA}$	Junction-to-ambient thermal resistance	109.5	119.8	°C/W
$R_{\theta JC(top)}$	Junction-to-case (top) thermal resistance	43.1	64.1	°C/W
$R_{\theta JB}$	Junction-to-board thermal resistance	51.2	65.4	°C/W
Ψ_{JT}	Junction-to-top characterization parameter	18.3	37.6	°C/W
Ψ_{JB}	Junction-to-board characterization parameter	50.7	63.7	°C/W

- (1) For more information about traditional and new thermal metrics, see the [Semiconductor and IC Package Thermal Metrics Application Report](#).

6.5 Power Ratings

PARAMETER		TEST CONDITIONS	MIN	TYP	MAX	UNIT
D Package (UCC5350MC-Q1)						
P_D	Maximum power dissipation on input and output	$V_{CC1} = 15\text{ V}$, $V_{CC2} = 15\text{ V}$, $f = 2.1\text{-MHz}$, 50% duty cycle, square wave, 2.2-nF load			1.14	W
P_{D1}	Maximum input power dissipation				0.05	W
P_{D2}	Maximum output power dissipation				1.09	W
D Package (UCC5350SB-Q1)						
P_D	Maximum power dissipation on input and output	$V_{CC1} = 15\text{ V}$, $V_{CC2} = 15\text{ V}$, $f = 1.8\text{-MHz}$, 50% duty cycle, square wave, 2.2-nF load			0.99	W
P_{D1}	Maximum input power dissipation				0.05	W
P_{D2}	Maximum output power dissipation				0.94	W
DWV Package (UCC5350MC-Q1)						
P_D	Maximum power dissipation on input and output	$V_{CC1} = 15\text{ V}$, $V_{CC2} = 15\text{ V}$, $f = 1.9\text{-MHz}$, 50% duty cycle, square wave, 2.2-nF load			1.04	W
P_{D1}	Maximum input power dissipation				0.05	W
P_{D2}	Maximum output power dissipation				0.99	W

6.6 Insulation Specifications for D Package

PARAMETER		TEST CONDITIONS	VALUE	UNIT
			D	
CLR	External Clearance ⁽¹⁾	Shortest pin-to-pin distance through air	≥ 4	mm
CPG	External Creepage ⁽¹⁾	Shortest pin-to-pin distance across the package surface	≥ 4	mm
DTI	Distance through the insulation	Minimum internal gap (internal clearance)	> 21	μm
CTI	Comparative tracking index	DIN EN 60112 (VDE 0303-11); IEC 60112	> 400	V
	Material Group	According to IEC 60664-1	II	
	Overvoltage category per IEC 60664-1	Rated mains voltage $\leq 150V_{RMS}$	I-IV	
		Rated mains voltage $\leq 300V_{RMS}$	I-III	
DIN V VDE 0884-11: 2017-01⁽²⁾				
V_{IORM}	Maximum repetitive peak isolation voltage	AC voltage (bipolar)	990 ⁽⁶⁾	V_{PK}
V_{IOWM}	Maximum isolation working voltage	AC voltage (sine wave); time dependent dielectric breakdown (TDDb) test	700 ⁽⁶⁾	V_{RMS}
		DC Voltage	990 ⁽⁶⁾	V_{DC}
V_{IOTM}	Maximum transient isolation voltage	$V_{TEST} = V_{IOTM}$, $t = 60\text{ s}$ (qualification); $V_{TEST} = 1.2 \times V_{IOTM}$, $t = 1\text{ s}$ (100% production)	4242	V_{PK}
V_{IOSM}	Maximum surge isolation voltage ⁽³⁾	Test method per IEC 62368-1, 1.2/50- μs waveform, $V_{TEST} = 1.3 \times V_{IOSM}$ (qualification)	4242	V_{PK}
q_{pd}	Apparent charge ⁽⁴⁾	Method a: After I/O safety test subgroup 2/3, $V_{ini} = V_{IOTM}$, $t_{ini} = 60\text{ s}$ $V_{pd(m)} = 1.2 \times V_{IORM}$, $t_m = 10\text{ s}$	≤ 5	pC
		Method a: After environmental tests subgroup 1, $V_{ini} = V_{IOTM}$, $t_{ini} = 60\text{ s}$; $V_{pd(m)} = 1.2 \times V_{IORM}$, $t_m = 10\text{ s}$	≤ 5	
		Method b1: At routine test (100% production) and preconditioning (type test), $V_{ini} = 1.2 \times V_{IOTM}$, $t_{ini} = 1\text{ s}$; $V_{pd(m)} = 1.5 \times V_{IORM}$, $t_m = 1\text{ s}$	≤ 5	
C_{IO}	Barrier capacitance, input to output ⁽⁵⁾	$V_{IO} = 0.4 \times \sin(2\pi ft)$, $f = 1\text{ MHz}$	1.2	pF

6.6 Insulation Specifications for D Package (続き)

PARAMETER	TEST CONDITIONS	VALUE	UNIT
		D	
R _{IO} Isolation resistance, input to output ⁽⁵⁾	V _{IO} = 500 V, T _A = 25°C	> 10 ¹²	Ω
	V _{IO} = 500 V, 100°C ≤ T _A ≤ 125°C	> 10 ¹¹	
	V _{IO} = 500 V at T _S = 150°C	> 10 ⁹	
Pollution degree		2	
Climatic category		40/125/21	
UL 1577			
V _{ISO} Withstand isolation voltage	V _{TEST} = V _{ISO} , t = 60 s (qualification); V _{TEST} = 1.2 × V _{ISO} , t = 1 s (100% production)	3000	V _{RMS}

- (1) Creepage and clearance requirements should be applied according to the specific equipment isolation standards of an application. Care should be taken to maintain the creepage and clearance distance of a board design to ensure that the mounting pads of the isolator on the printed-circuit board do not reduce this distance. Creepage and clearance on a printed-circuit board become equal in certain cases. Techniques such as inserting grooves, ribs, or both on a printed circuit board are used to help increase these specifications.
- (2) This coupler is suitable for basic electrical insulation only within the maximum operating ratings. Compliance with the safety ratings shall be ensured by means of suitable protective circuits.
- (3) Testing is carried out in air or oil to determine the intrinsic surge immunity of the isolation barrier.
- (4) Apparent charge is electrical discharge caused by a partial discharge (pd).
- (5) All pins on each side of the barrier tied together creating a two-pin device.
- (6) System isolation working voltages need to be verified according to application parameters.

6.7 Insulation Specifications for DWV Package

PARAMETER		TEST CONDITIONS	VALUE	UNIT
			DWV	
CLR	External Clearance ⁽¹⁾	Shortest pin-to-pin distance through air	≥ 8.5	mm
CPG	External Creepage ⁽¹⁾	Shortest pin-to-pin distance across the package surface	≥ 8.5	mm
DTI	Distance through the insulation	Minimum internal gap (internal clearance)	> 21	μm
CTI	Comparative tracking index	DIN EN 60112 (VDE 0303-11); IEC 60112	> 600	V
	Material Group	According to IEC 60664-1	I	
Overvoltage category per IEC 60664-1		Rated mains voltage ≤ 600 _V RMS	I-III	
		Rated mains voltage ≤ 1000 _V RMS	I-II	
DIN V VDE 0884-11: 2017-01⁽²⁾				
V _{IORM}	Maximum repetitive peak isolation voltage	AC voltage (bipolar)	2121	V _{PK}
V _{IOWM}	Maximum isolation working voltage	AC voltage (sine wave); time dependent dielectric breakdown (TDDb) test	1500	V _{RMS}
		DC Voltage	2121	V _{DC}
V _{IOTM}	Maximum transient isolation voltage	V _{TEST} = V _{IOTM} , t = 60 s (qualification) ; V _{TEST} = 1.2 × V _{IOTM} , t = 1 s (100% production)	7000	V _{PK}
V _{IOSM}	Maximum surge isolation voltage ⁽³⁾	Test method per IEC 62368-1, 1.2/50-μs waveform, V _{TEST} = 1.6 × V _{IOSM} (qualification)	8000	V _{PK}
q _{pd}	Apparent charge ⁽⁴⁾	Method a: After I/O safety test subgroup 2/3, V _{ini} = V _{IOTM} , t _{ini} = 60 s V _{pd(m)} = 1.2 × V _{IORM} , t _m = 10 s	≤ 5	pC
		Method a: After environmental tests subgroup 1, V _{ini} = V _{IOTM} , t _{ini} = 60 s; V _{pd(m)} = 1.6 × V _{IORM} , t _m = 10 s	≤ 5	
		Method b1: At routine test (100% production) and preconditioning (type test), V _{ini} = 1.2 × V _{IOTM} , t _{ini} = 1 s; V _{pd(m)} = 1.875 × V _{IORM} , t _m = 1 s	≤ 5	
C _{IO}	Barrier capacitance, input to output ⁽⁵⁾	V _{IO} = 0.4 × sin(2πft), f = 1 MHz	1.2	pF
R _{IO}	Isolation resistance, input to output ⁽⁵⁾	V _{IO} = 500 V, T _A = 25°C	> 10 ¹²	Ω
		V _{IO} = 500 V, 100°C ≤ T _A ≤ 125°C	> 10 ¹¹	
		V _{IO} = 500 V at T _S = 150°C	> 10 ⁹	
	Pollution degree		2	
	Climatic category		40/125/21	
UL 1577				
V _{ISO}	Withstand isolation voltage	V _{TEST} = V _{ISO} , t = 60 s (qualification); V _{TEST} = 1.2 × V _{ISO} , t = 1 s (100% production)	5000	V _{RMS}

- (1) Creepage and clearance requirements should be applied according to the specific equipment isolation standards of an application. Care should be taken to maintain the creepage and clearance distance of a board design to ensure that the mounting pads of the isolator on the printed-circuit board do not reduce this distance. Creepage and clearance on a printed-circuit board become equal in certain cases. Techniques such as inserting grooves, ribs, or both on a printed circuit board are used to help increase these specifications.
- (2) This coupler is suitable for safe electrical insulation only within the safety ratings. Compliance with the safety ratings shall be ensured by means of suitable protective circuits.
- (3) Testing is carried out in air or oil to determine the intrinsic surge immunity of the isolation barrier.
- (4) Apparent charge is electrical discharge caused by a partial discharge (pd).
- (5) All pins on each side of the barrier tied together creating a two-pin device.

6.8 Safety-Related Certifications For D Package

UL
Recognized under UL 1577 Component Recognition Program
Single protection, 3000 V _{RMS}
File Number: E181974

6.9 Safety-Related Certifications For DWV Package

UL
Recognized under UL 1577 Component Recognition Program
Single protection, 5000 V _{RMS}
File Number: E181974

6.10 Safety Limiting Values

Safety limiting intends to minimize potential damage to the isolation barrier upon failure of input or output circuitry.

PARAMETER	TEST CONDITIONS	MIN	TYP	MAX	UNIT	
D PACKAGE (UCC5350MC-Q1)						
I _S	Safety output supply current	R _{θJA} = 109.5°C/W, V _{CC2} = 15 V, T _J = 150°C, T _A = 25°C, see 6-2	Output side		73	mA
		R _{θJA} = 109.5°C/W, V _{CC2} = 30 V, T _J = 150°C, T _A = 25°C, see 6-2	Output side		36	
P _S	Safety output supply power	R _{θJA} = 109.5°C/W, T _J = 150°C, T _A = 25°C, see 6-4	Input side		0.05	W
			Output side		1.09	
			Total		1.14	
T _S	Maximum safety temperature ⁽¹⁾			150	°C	
D PACKAGE (UCC5350SB-Q1)						
I _S	Safety output supply current	R _{θJA} = 109.5°C/W, V _{CC2} = 15 V, T _J = 150°C, T _A = 25°C, see 6-2	Output side		63	mA
		R _{θJA} = 109.5°C/W, V _{CC2} = 30 V, T _J = 150°C, T _A = 25°C, see 6-2	Output side		31	
P _S	Safety output supply power	R _{θJA} = 109.5°C/W, T _J = 150°C, T _A = 25°C, see 6-4	Input side		0.05	W
			Output side		0.94	
			Total		0.99	
T _S	Maximum safety temperature ⁽¹⁾			150	°C	
DWV PACKAGE (UCC5350MC-Q1)						
I _S	Safety input, output, or supply current	R _{θJA} = 119.8°C/W, V _I = 15 V, T _J = 150°C, T _A = 25°C, see 6-1	Output side		66	mA
		R _{θJA} = 119.8°C/W, V _I = 30 V, T _J = 150°C, T _A = 25°C, see 6-1	Output side		33	
P _S	Safety input, output, or total power	R _{θJA} = 119.8°C/W, T _J = 150°C, T _A = 25°C, see 6-3	Input side		0.05	W
			Output side		0.99	
			Total		1.04	
T _S	Maximum safety temperature ⁽¹⁾			150	°C	

- (1) The maximum safety temperature, T_S, has the same value as the maximum junction temperature, T_J, specified for the device. The I_S and P_S parameters represent the safety current and safety power respectively. The maximum limits of I_S and P_S should not be exceeded. These limits vary with the ambient temperature, T_A.

The junction-to-air thermal resistance, R_{θJA}, in the Thermal Information table is that of a device installed on a high-K test board for leaded surface-mount packages. Use these equations to calculate the value for each parameter:

$$T_J = T_A + R_{\theta JA} \times P, \text{ where } P \text{ is the power dissipated in the device.}$$

$T_{J(max)} = T_S = T_A + R_{\theta JA} \times P_S$, where $T_{J(max)}$ is the maximum allowed junction temperature.

$P_S = I_S \times V_I$, where V_I is the maximum input voltage.

6.11 Electrical Characteristics

$V_{CC1} = 3.3\text{ V}$ or 5 V , $0.1\text{-}\mu\text{F}$ capacitor from V_{CC1} to GND1, $V_{CC2} = 15\text{ V}$, $1\text{-}\mu\text{F}$ capacitor from V_{CC2} to V_{EE2} , $C_L = 100\text{-pF}$, $T_J = -40^\circ\text{C}$ to $+125^\circ\text{C}$ (UCC5350MC-Q1), $T_J = -40^\circ\text{C}$ to $+150^\circ\text{C}$ (UCC5350SB-Q1), (unless otherwise noted)

PARAMETER		TEST CONDITIONS	MIN	TYP	MAX	UNIT
SUPPLY CURRENTS						
I_{VCC1}	Input supply quiescent current			1.67	2.4	mA
I_{VCC2}	Output supply quiescent current			1.1	1.8	mA
SUPPLY VOLTAGE UNDERVOLTAGE THRESHOLDS						
$V_{IT+(UVLO1)}$	VCC1 Positive-going UVLO threshold voltage			2.6	2.8	V
$V_{IT-(UVLO1)}$	VCC1 Negative-going UVLO threshold voltage		2.4	2.5		V
$V_{hys(UVLO1)}$	VCC1 UVLO threshold hysteresis			0.1		V
OUTPUT SUPPLY VOLTAGE UNDERVOLTAGE THRESHOLDS (UCC5350MC-Q1)						
$V_{IT+(UVLO2)}$	VCC2 Positive-going UVLO threshold voltage			12	13	V
$V_{IT-(UVLO2)}$	VCC2 Negative-going UVLO threshold voltage		10.3	11		V
$V_{hys(UVLO2)}$	VCC2 UVLO threshold voltage hysteresis			1		V
OUTPUT SUPPLY VOLTAGE UNDERVOLTAGE THRESHOLDS (UCC5350SB-Q1)						
$V_{IT+(UVLO2)}$	VCC2 Positive-going UVLO threshold voltage			8.7	9.4	V
$V_{IT-(UVLO2)}$	VCC2 Negative-going UVLO threshold voltage		7.3	8.0		V
$V_{hys(UVLO2)}$	VCC2 UVLO threshold voltage hysteresis			0.7		V
LOGIC I/O						
$V_{IT+(IN)}$	Positive-going input threshold voltage (IN+, IN-)			$0.55 \times V_{CC1}$	$0.7 \times V_{CC1}$	V
$V_{IT-(IN)}$	Negative-going input threshold voltage (IN+, IN-)		$0.3 \times V_{CC1}$	$0.45 \times V_{CC1}$		V
$V_{hys(IN)}$	Input hysteresis voltage (IN+, IN-)			$0.1 \times V_{CC1}$		V
I_{IH}	High-level input leakage at IN+	IN+ = V_{CC1}		40	240	μA
I_{IL}	Low-level input leakage at IN-	IN- = GND1		-240	-40	μA
		IN- = GND1 - 5 V		-310	-80	
GATE DRIVER STAGE						
V_{OH}	High-level output voltage (VCC2 - OUT) and (VCC2 - OUTH)	$I_{OUT} = -20\text{ mA}$	100	240		mV
V_{OL}	Low level output voltage (OUT and OUTL)	IN+ = low, IN- = high; $I_{OUT} = 20\text{ mA}$	5	7		mV
I_{OH}	Peak source current	UCC5350MC, IN+ = high, IN- = low	5	10		A
		UCC5350SB, IN+ = high, IN- = low	5	8.5		A
I_{OL}	Peak sink current	IN+ = low, IN- = high	5	10		A

6.11 Electrical Characteristics (続き)

$V_{CC1} = 3.3\text{ V}$ or 5 V , $0.1\text{-}\mu\text{F}$ capacitor from V_{CC1} to GND1, $V_{CC2} = 15\text{ V}$, $1\text{-}\mu\text{F}$ capacitor from V_{CC2} to V_{EE2} , $C_L = 100\text{-pF}$, $T_J = -40^\circ\text{C}$ to $+125^\circ\text{C}$ (UCC5350MC-Q1), $T_J = -40^\circ\text{C}$ to $+150^\circ\text{C}$ (UCC5350SB-Q1), (unless otherwise noted)

PARAMETER		TEST CONDITIONS	MIN	TYP	MAX	UNIT
Active Miller Clamp (UCC5350MC-Q1 only)						
V_{CLAMP}	Low-level clamp voltage	$I_{CLAMP} = 20\text{ mA}$		7	10	mV
I_{CLAMP}	Clamp low-level current	$V_{CLAMP} = V_{EE2} + 15\text{ V}$	5	10		A
$I_{CLAMP(L)}$	Clamp low-level current for low output voltage	$V_{CLAMP} = V_{EE2} + 2\text{ V}$	5	10		A
$V_{CLAMP-TH}$	Clamp threshold voltage			2.1	2.3	V
SHORT CIRCUIT CLAMPING						
$V_{CLP-OUT}$	Clamping voltage ($V_{OUT} - V_{CC2}$)	$IN+ = \text{high}$, $IN- = \text{low}$, $t_{CLAMP} = 10\text{ }\mu\text{s}$, $I_{OUT} = 500\text{ mA}$		1	1.3	V
$V_{CLP-OUT}$	Clamping voltage ($V_{EE2} - V_{OUT}$)	$IN+ = \text{low}$, $IN- = \text{high}$, $t_{CLAMP} = 10\text{ }\mu\text{s}$, $I_{OUT} = -500\text{ mA}$		1.5		V
		$IN+ = \text{low}$, $IN- = \text{high}$, $I_{OUT} = -20\text{ mA}$		0.9	1	
ACTIVE PULLDOWN						
V_{OUTSD}	Active pull-down voltage on OUT	$I_{OUT} = 0.1 \times I_{OUT(typ)}$, $V_{CC2} = \text{open}$		1.8	2.5	V

6.12 Switching Characteristics

$V_{CC1} = 3.3\text{ V}$ or 5 V , $0.1\text{-}\mu\text{F}$ capacitor from V_{CC1} to GND1, $V_{CC2} = 15\text{ V}$, $1\text{-}\mu\text{F}$ capacitor from V_{CC2} to V_{EE2} , $T_J = -40^\circ\text{C}$ to $+125^\circ\text{C}$, (unless otherwise noted)

PARAMETER		TEST CONDITIONS	MIN	TYP	MAX	UNIT
t_r	Output-signal rise time	$C_{LOAD} = 1\text{ nF}$		10	26	ns
t_f	Output-signal fall time	$C_{LOAD} = 1\text{ nF}$		10	22	ns
t_{PLH}	Propagation delay, high	$C_{LOAD} = 100\text{ pF}$		65	100	ns
t_{PHL}	Propagation delay, low	$C_{LOAD} = 100\text{ pF}$		65	100	ns
t_{UVLO1_rec}	UVLO recovery delay of V_{CC1}	See Figure 8-7 .		30		μs
t_{UVLO2_rec}	UVLO recovery delay of V_{CC2}	See Figure 8-7 .		50		μs
t_{PWD}	Pulse width distortion $ t_{PHL} - t_{PLH} $	$C_{LOAD} = 100\text{ pF}$		1	20	ns
$t_{sk(pp)}$	Part-to-part skew ⁽¹⁾	$C_{LOAD} = 100\text{ pF}$		1	25	ns
t_{PWmin1}	No response at OUT where $OUT < 10\% \times V_{CC2}$	$C_{LOAD} = 100\text{ pF}$	8			ns
t_{PWmin2}	No response at OUT where $OUT \geq 90\% \times V_{CC2}$	$C_{LOAD} = 100\text{ pF}$			38	ns
CMTI	Common-mode transient immunity	PWM is tied to GND or V_{CC1} , $V_{CM} = 1200\text{ V}$	100	120		kV/ μs

(1) $t_{sk(pp)}$ is the magnitude of the difference in propagation delay times between the output of different devices switching in the same direction while operating at identical supply voltages, temperature, input signals and loads guaranteed by characterization.

6.13 Insulation Characteristics Curves

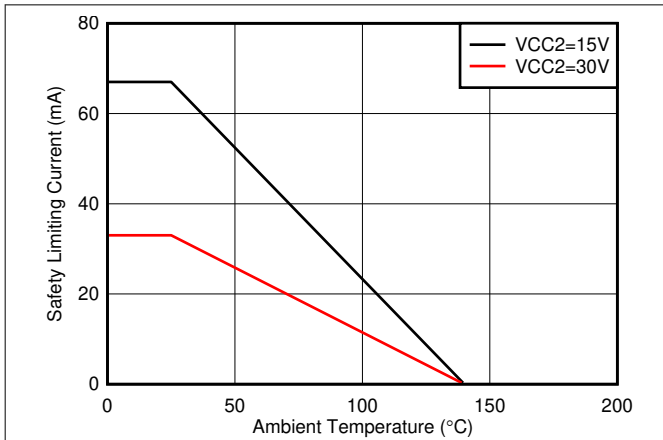

6-1. Thermal Derating Curve for Limiting Current per VDE for DWV Package

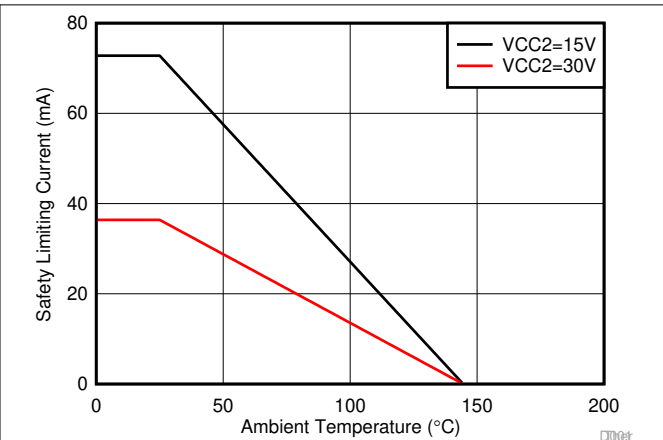

6-2. Thermal Derating Curve for Limiting Current per VDE for D Package

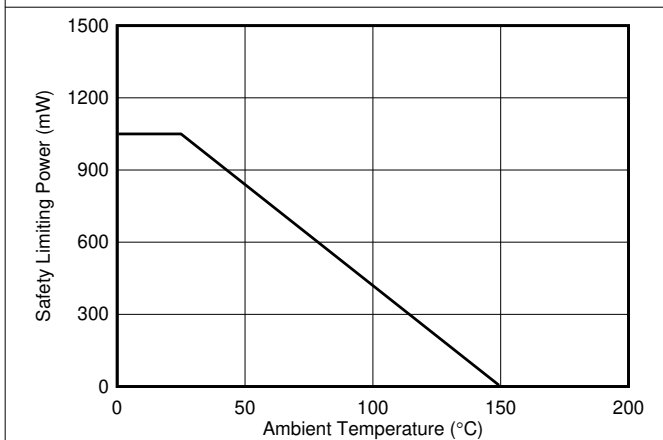

6-3. Thermal Derating Curve for Limiting Power per VDE for DWV Package

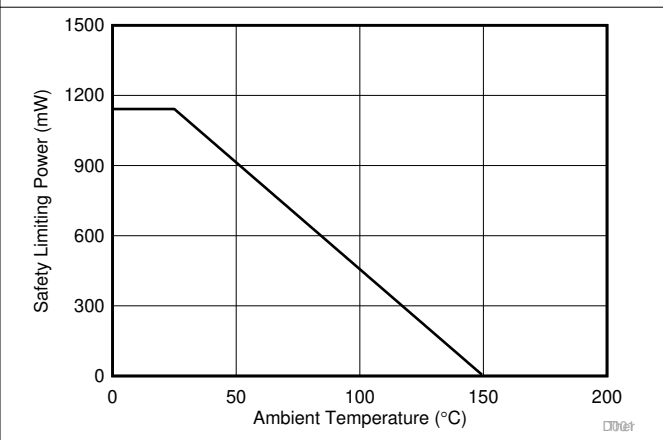

6-4. Thermal Derating Curve for Limiting Power per VDE for D Package

6.14 Typical Characteristics

$V_{CC1} = 3.3\text{ V}$ or 5 V , $0.1\text{-}\mu\text{F}$ capacitor from V_{CC1} to GND1 , $V_{CC2} = 15\text{ V}$, $1\text{-}\mu\text{F}$ capacitor from V_{CC2} to V_{EE2} , $C_{LOAD} = 1\text{ nF}$, $T_J = -40^\circ\text{C}$ to $+125^\circ\text{C}$, (unless otherwise noted)

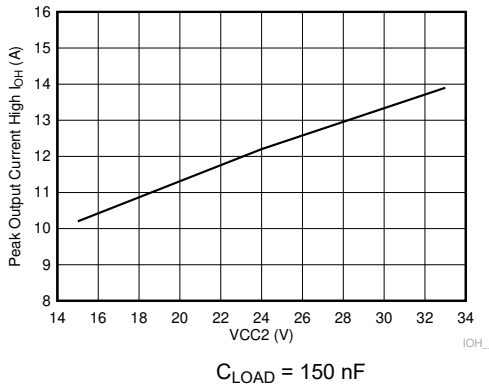

6-5. Output-High Drive Current vs Output Voltage

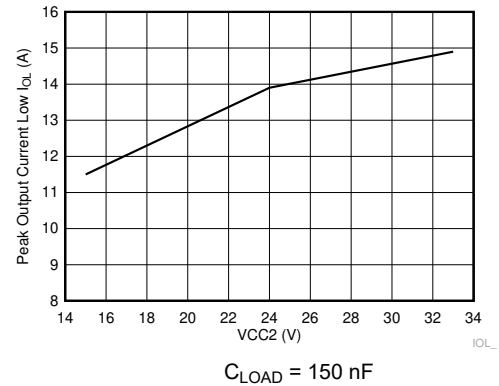

6-6. Output-Low Drive Current vs Output Voltage

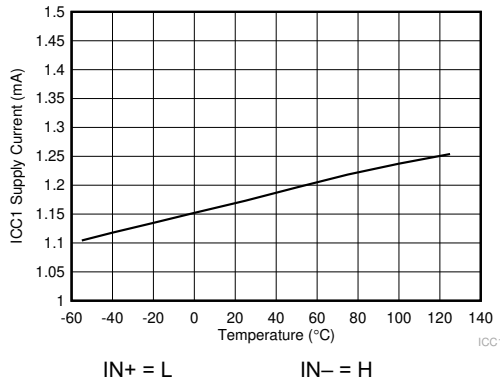

6-7. I_{CC1} Supply Current vs Temperature

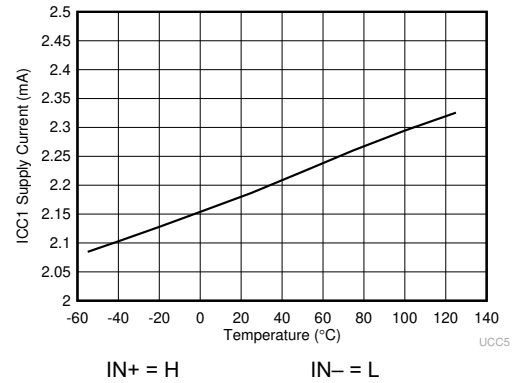

6-8. I_{CC1} Supply Current vs Temperature

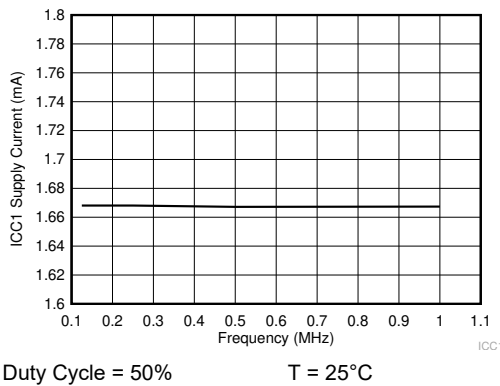

6-9. I_{CC1} Supply Current vs Input Frequency

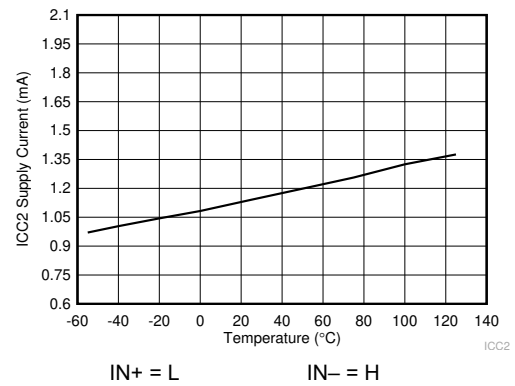

6-10. I_{CC2} Supply Current vs Temperature

6.14 Typical Characteristics (continued)

$V_{CC1} = 3.3\text{ V}$ or 5 V , $0.1\text{-}\mu\text{F}$ capacitor from V_{CC1} to GND1, $V_{CC2} = 15\text{ V}$, $1\text{-}\mu\text{F}$ capacitor from V_{CC2} to V_{EE2} , $C_{LOAD} = 1\text{ nF}$, $T_J = -40^\circ\text{C}$ to $+125^\circ\text{C}$, (unless otherwise noted)

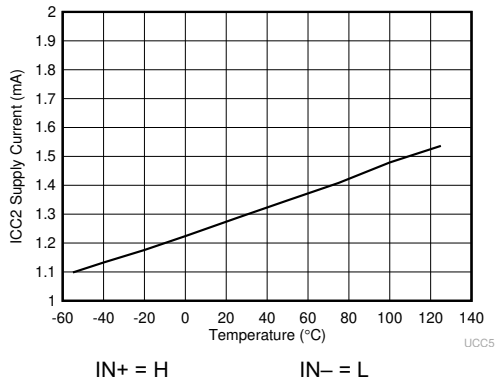

Figure 6-11. ICC2 Supply Current vs Temperature

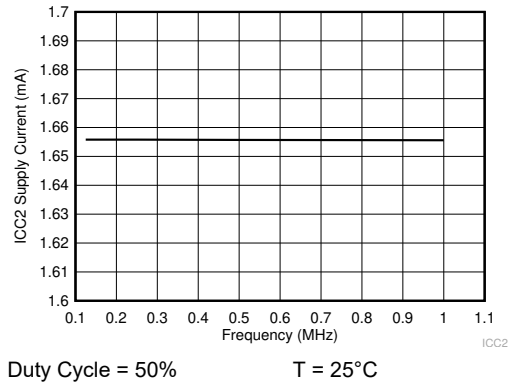

Figure 6-12. ICC2 Supply Current vs Input Frequency

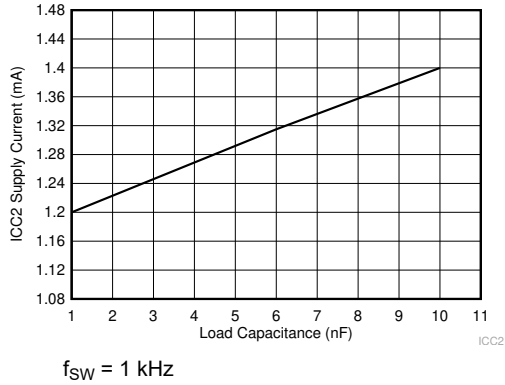

Figure 6-13. ICC2 Supply Current vs Load Capacitance

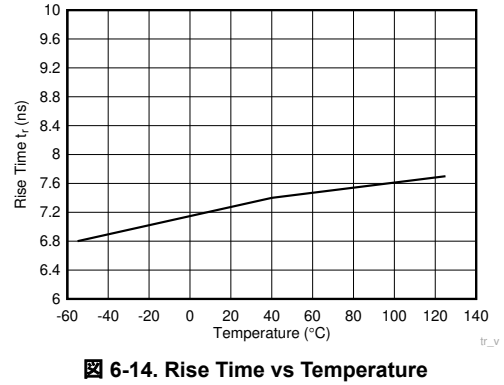

Figure 6-14. Rise Time vs Temperature

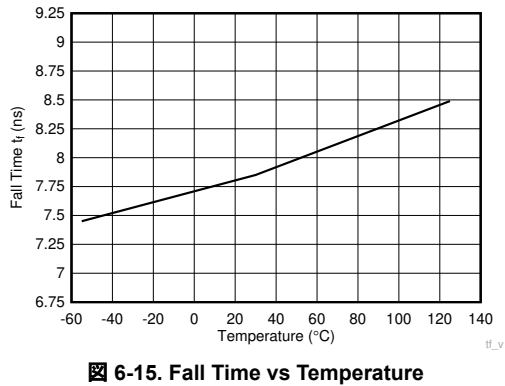

Figure 6-15. Fall Time vs Temperature

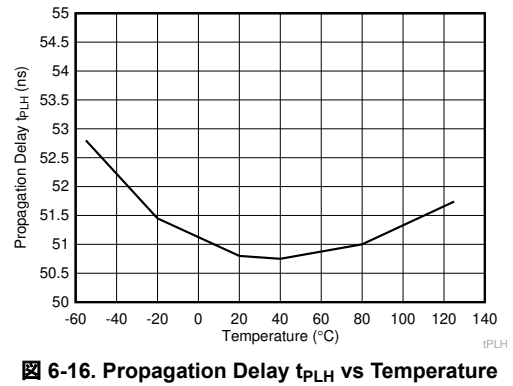

Figure 6-16. Propagation Delay tPLH vs Temperature

6.14 Typical Characteristics (continued)

$V_{CC1} = 3.3\text{ V}$ or 5 V , $0.1\text{-}\mu\text{F}$ capacitor from V_{CC1} to GND1 , $V_{CC2} = 15\text{ V}$, $1\text{-}\mu\text{F}$ capacitor from V_{CC2} to V_{EE2} , $C_{LOAD} = 1\text{ nF}$, $T_J = -40^\circ\text{C}$ to $+125^\circ\text{C}$, (unless otherwise noted)

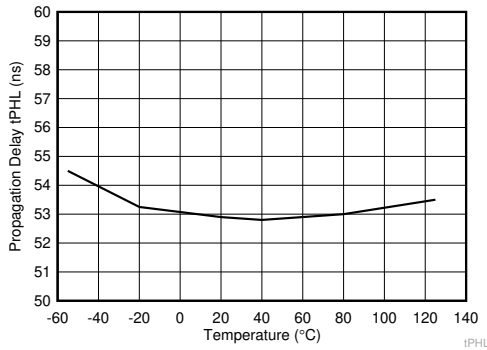
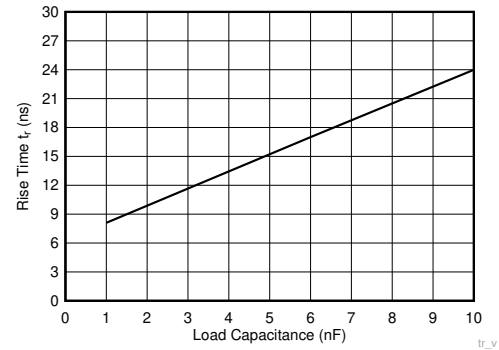
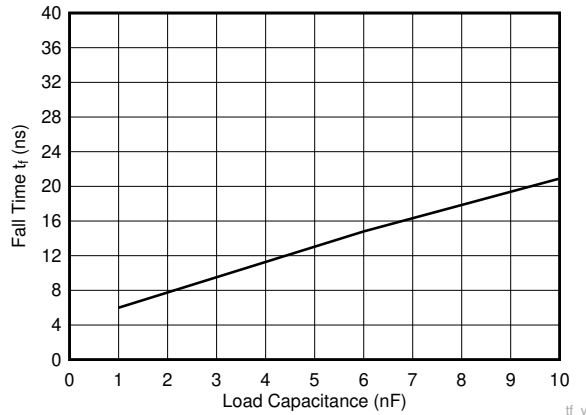

Figure 6-17. Propagation Delay t_{PHL} vs Temperature



$f_{SW} = 1\text{ kHz}$ $R_{GH} = 0\ \Omega$ $R_{GL} = 0\ \Omega$

Figure 6-18. Rise Time vs Load Capacitance



$f_{SW} = 1\text{ kHz}$ $R_{GH} = 0\ \Omega$ $R_{GL} = 0\ \Omega$

Figure 6-19. Fall Time vs Load Capacitance

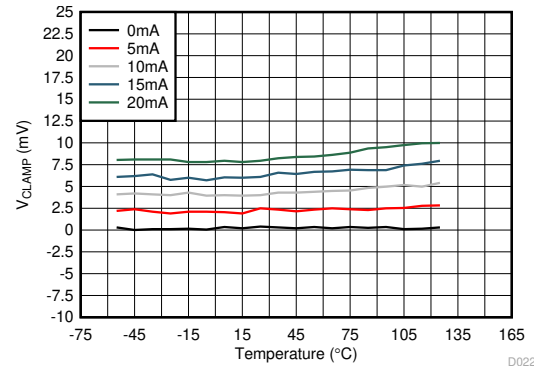

Figure 6-20. V_{CLAMP} vs Temperature

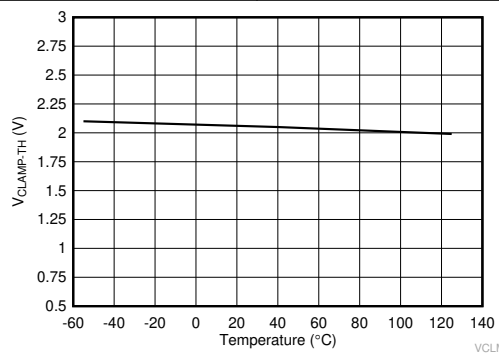

Figure 6-21. $V_{CLAMP-TH}$ vs Temperature

7 Parameter Measurement Information

7.1 Propagation Delay, Inverting, and Noninverting Configuration

Figure 7-1 shows the propagation delay for noninverting configurations. Figure 7-2 shows the propagation delay with the inverting configuration. These figures also demonstrate the method used to measure the rise (t_r) and fall (t_f) times.

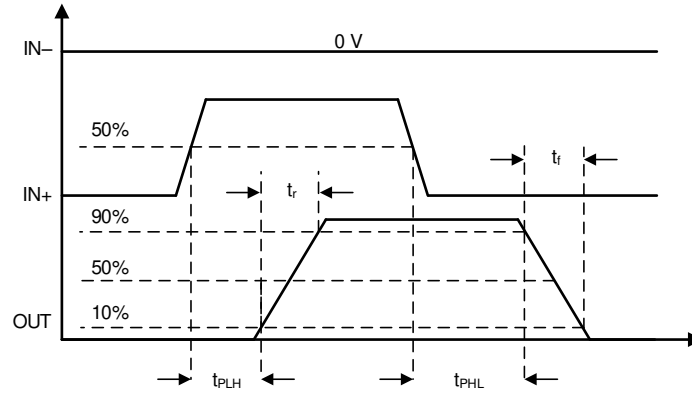

Figure 7-1. Propagation Delay, Noninverting Configuration

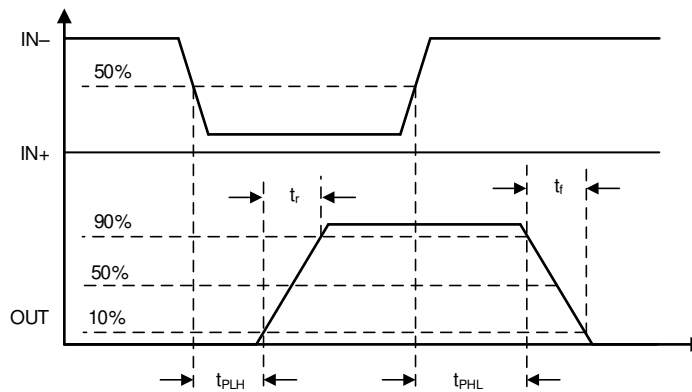



Figure 7-2. Propagation Delay, Inverting Configuration

7.1.1 CMTI Testing

 **7-3** and  **7-4** are simplified diagrams of the CMTI testing configuration.



图 7-3. CMTI Test Circuit for Split Output (UCC5350SB)



图 7-4. CMTI Test Circuit for Miller Clamp (UCC5350MC)

8 Detailed Description

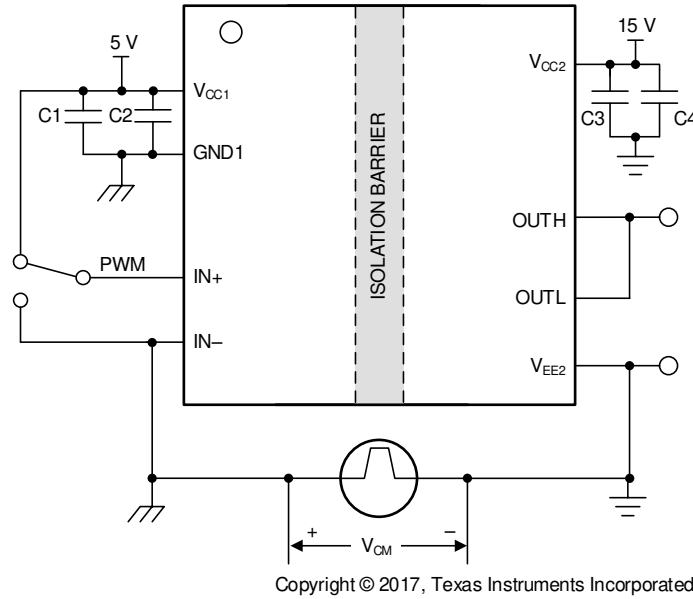
8.1 Overview

The UCC5350-Q1 family of isolated gate drivers has two variations: split output, and Miller clamp. The isolation inside the UCC5350-Q1 is implemented with high-voltage SiO₂-based capacitors. The signal across the isolation has an on-off keying (OOK) modulation scheme to transmit the digital data across a silicon dioxide based isolation barrier (see [Figure 8-2](#)). The transmitter sends a high-frequency carrier across the barrier to represent one digital state and sends no signal to represent the other digital state. The receiver demodulates the signal after advanced signal conditioning and produces the output through a buffer stage. The UCC5350-Q1 also incorporates advanced circuit techniques to maximize the CMTI performance and minimize the radiated emissions from the high frequency carrier and IO buffer switching. The conceptual block diagram of a digital capacitive isolator, [Figure 8-1](#), shows a functional block diagram of a typical channel. [Figure 8-2](#) shows a conceptual detail of how the OOK scheme works.

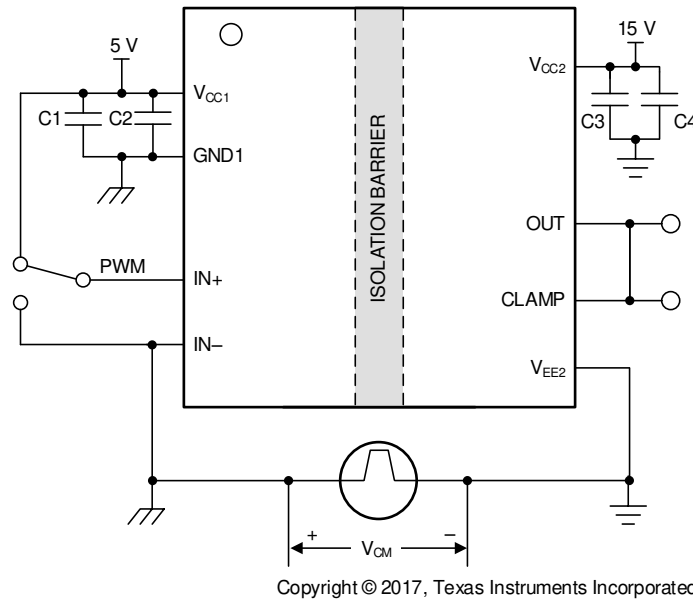
[Figure 8-1](#) shows how the input signal passes through the capacitive isolation barrier through modulation (OOK) and signal conditioning.

8.2 Functional Block Diagram

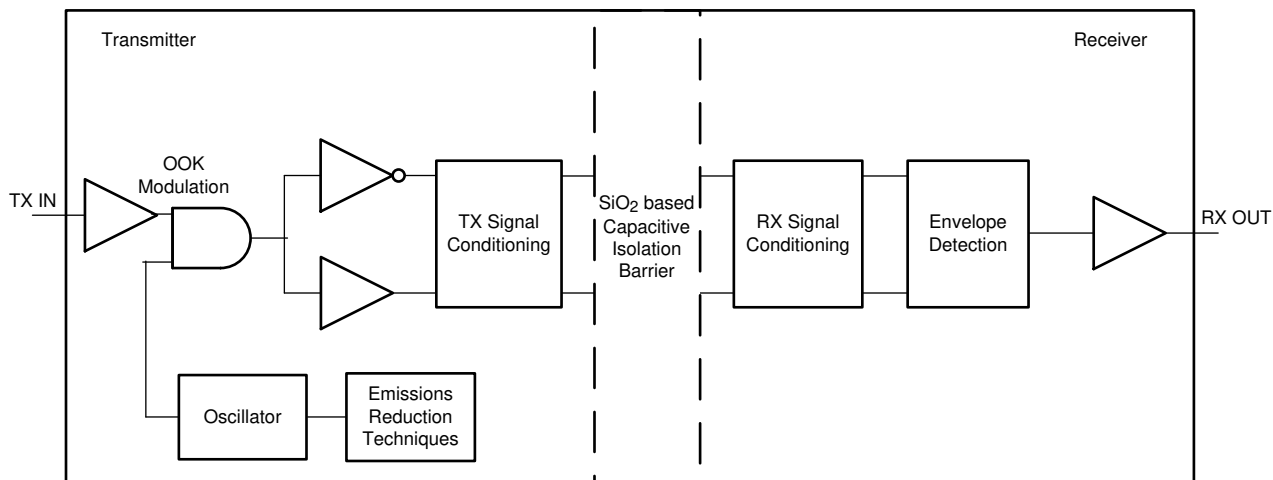

Figure 8-1. Conceptual Block Diagram of a Capacitive Data Channel

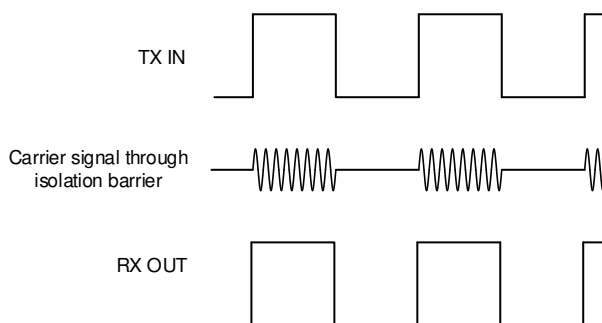
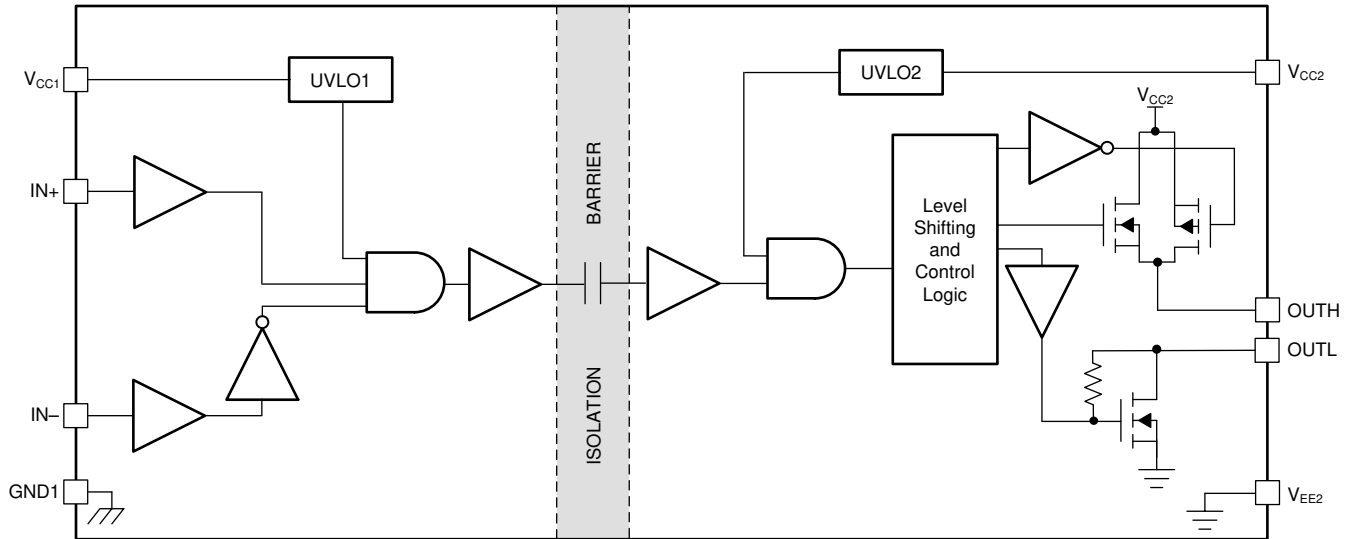
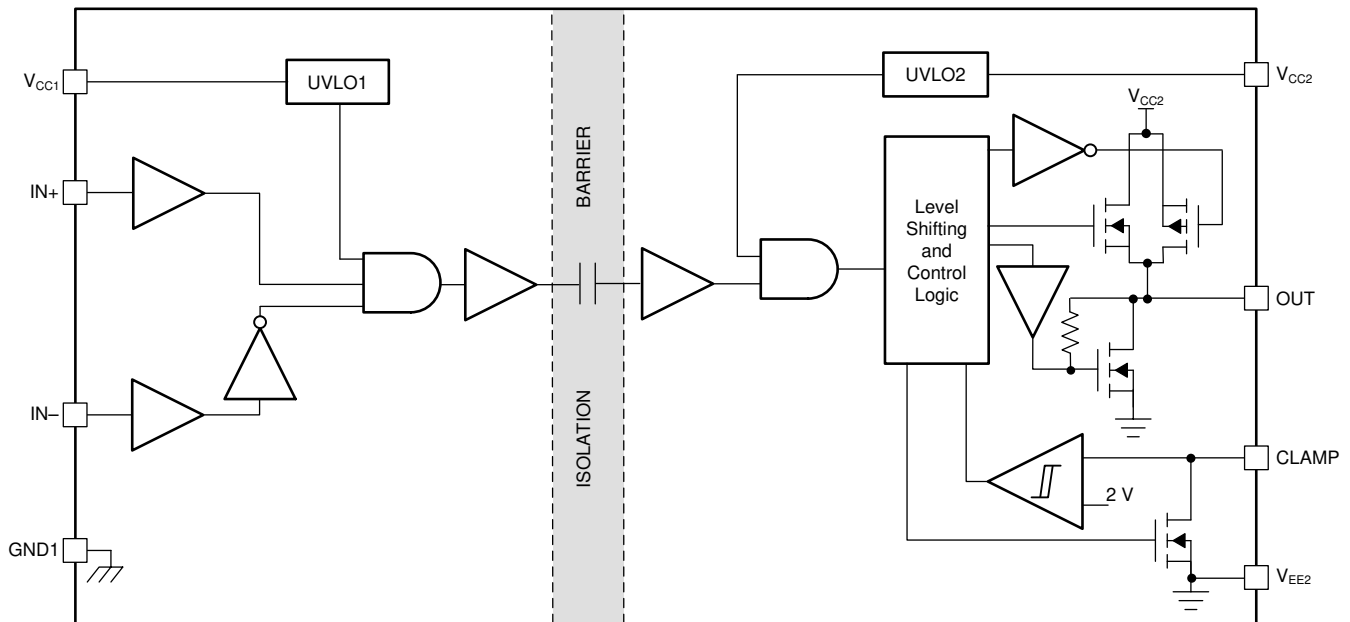

Figure 8-2. On-Off Keying (OOK) Based Modulation Scheme



8-3. Functional Block Diagram — Split Output



8-4. Functional Block Diagram — Miller Clamp

8.3 Feature Description

8.3.1 Power Supply

The V_{CC1} input power supply supports a wide voltage range from 3 V to 15 V and the V_{CC2} output supply supports a voltage range from 13.2 V to 33 V (UCC5350MC) or 9.5 V to 33 V (UCC5350SB).

For operation with unipolar supply, the V_{CC2} supply is connected to 15 V with respect to V_{EE2} for IGBTs, and 20 V for SiC MOSFETs. The V_{EE2} supply is connected to 0 V. In this use case, the Miller clamp helps to prevent a false turn-on of the power switch without a negative voltage rail. The Miller clamping function is implemented by adding a low impedance path between the gate of the power device and the V_{EE2} supply. Miller current sinks through the clamp pin, which clamps the gate voltage to be lower than the turn-on threshold value for the gate.

8.3.2 Input Stage

The input pins (IN+ and IN–) of the UCC5350-Q1 are based on CMOS-compatible input-threshold logic that is completely isolated from the V_{CC2} supply voltage. The input pins are easy to drive with logic-level control signals (such as those from 3.3-V microcontrollers), because the UCC5350-Q1 has a typical high threshold ($V_{IT+(IN)}$) of $0.55 \times V_{CC1}$ and a typical low threshold of $0.45 \times V_{CC1}$. A wide hysteresis ($V_{hys(IN)}$) of $0.1 \times V_{CC1}$ makes for good noise immunity and stable operation. If either of the inputs are left open, 128 k Ω of internal pull-down resistance forces the IN+ pin low and 128 k Ω of internal resistance pulls IN– high. However, TI still recommends grounding an input or tying to VCC1 if it is not being used for improved noise immunity.

Because the input side of the UCC5350-Q1 is isolated from the output driver, the input signal amplitude can be larger or smaller than V_{CC2} provided that it does not exceed the recommended limit. This feature allows greater flexibility when integrating the gate-driver with control signal sources and allows the user to choose the most efficient V_{CC2} for any gate. However, the amplitude of any signal applied to IN+ or IN– must never be at a voltage higher than V_{CC1} .

8.3.3 Output Stage

The output stage of the UCC5350-Q1 features a pull-up structure that delivers the highest peak-source current when it is most needed which is during the Miller plateau region of the power-switch turn-on transition (when the power-switch drain or collector voltage experiences dV/dt). The output stage pull-up structure features a P-channel MOSFET and an additional pull-up N-channel MOSFET in parallel. The function of the N-channel MOSFET is to provide a brief boost in the peak-sourcing current, which enables fast turn-on. Fast turn-on is accomplished by briefly turning on the N-channel MOSFET during a narrow instant when the output is changing states from low to high. 表 8-1 lists the typical internal resistance values of the pull-up and pull-down structure.

表 8-1. UCC5350-Q1 On-Resistance

DEVICE OPTION	R_{NMOS}	R_{OH}	R_{OL}	R_{CLAMP}	UNIT
UCC5350MC-Q1	1.54	12	0.26	0.26	Ω
UCC5350SB-Q1	1.54	12	0.26	Not applicable	Ω

The R_{OH} parameter is a DC measurement and is representative of the on-resistance of the P-channel device only. This parameter is only for the P-channel device, because the pull-up N-channel device is held in the OFF state in DC condition and is turned on only for a brief instant when the output is changing states from low to high. Therefore, the effective resistance of the UCC5350-Q1 pull-up stage during this brief turn-on phase is much lower than what is represented by the R_{OH} parameter, which yields a faster turn-on. The turn-on-phase output resistance is the parallel combination $R_{OH} \parallel R_{NMOS}$.

The pull-down structure in the UCC5350-Q1 is simply composed of an N-channel MOSFET. The output of the UCC5350-Q1 is capable of delivering, or sinking, 5-A peak current pulses. The output voltage swing between V_{CC2} and V_{EE2} provides rail-to-rail operation because of the MOS-out stage which delivers very low dropout.



図 8-5. Output Stage—S Version



図 8-6. Output Stage—M Version

8.3.4 Protection Features

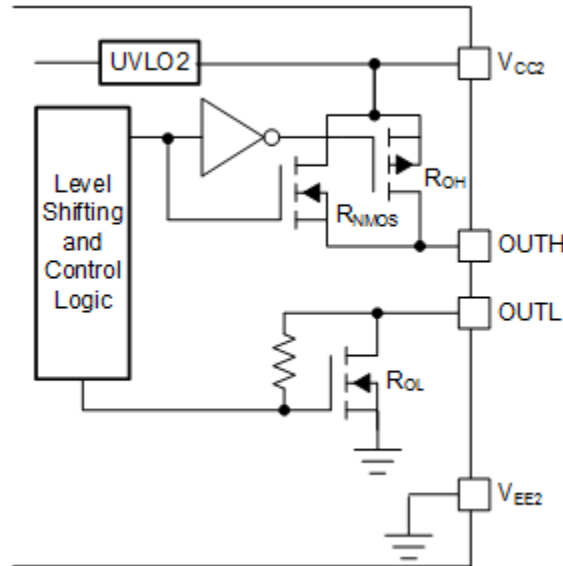
8.3.4.1 Undervoltage Lockout (UVLO)

UVLO functions are implemented for both the V_{CC1} and V_{CC2} supplies between the V_{CC1} and GND1, and V_{CC2} and V_{EE2} pins to prevent an underdriven condition on IGBTs and MOSFETs. When V_{CC} is lower than V_{IT+} (UVLO) at device start-up or lower than V_{IT-} (UVLO) after start-up, the voltage-supply UVLO feature holds the effected output low, regardless of the input pins (IN+ and IN-) as shown in 表 8-2. The V_{CC} UVLO protection has a hysteresis feature (V_{hys} (UVLO)). This hysteresis prevents chatter when the power supply produces ground noise; this allows the device to permit small drops in bias voltage, which occurs when the device starts switching and operating current consumption increases suddenly. 図 8-7 shows the UVLO functions.

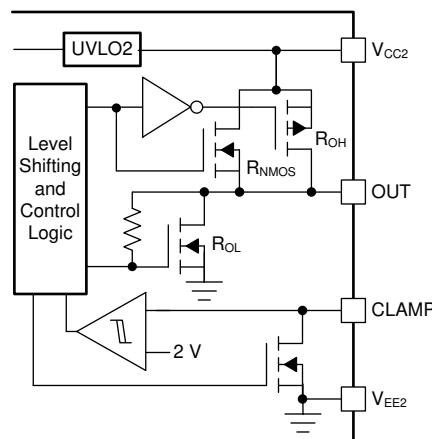
表 8-2. UCC5350-Q1 V_{CC1} UVLO Logic

CONDITION	INPUTS		OUTPUT
	IN+	IN-	OUT
$V_{CC1} - GND1 < V_{IT+(UVLO1)}$ during device start-up	H	L	L
	L	H	L
	H	H	L
	L	L	L
$V_{CC1} - GND1 < V_{IT-(UVLO1)}$ after device start-up	H	L	L
	L	H	L
	H	H	L
	L	L	L

表 8-3. UCC5350-Q1 V_{CC2} UVLO Logic

CONDITION	INPUTS		OUTPUT
	IN+	IN-	OUT
$V_{CC2} - V_{EE2} < V_{IT+(UVLO2)}$ during device start-up	H	L	L
	L	H	L
	H	H	L
	L	L	L
$V_{CC2} - V_{EE2} < V_{IT-(UVLO2)}$ after device start-up	H	L	L
	L	H	L
	H	H	L
	L	L	L

When V_{CC1} or V_{CC2} drops below the UVLO1 or UVLO2 threshold, a delay, t_{UVLO1_rec} or t_{UVLO2_rec} , occurs on the output when the supply voltage rises above $V_{IT+(UVLO)}$ or $V_{IT+(UVLO2)}$ again. [図 8-7](#) shows this delay.



図 8-7. UVLO Functions

8.3.4.2 Active Pulldown

The active pull-down function is used to pull the IGBT or MOSFET gate to the low state when no power is connected to the V_{CC2} supply. This feature prevents false IGBT and MOSFET turn-on on the OUT and CLAMP pins by clamping the output to approximately 2 V.

When the output stages of the driver are in an unbiased or UVLO condition, the driver outputs are held low by an active clamp circuit that limits the voltage rise on the driver outputs. In this condition, the upper PMOS is

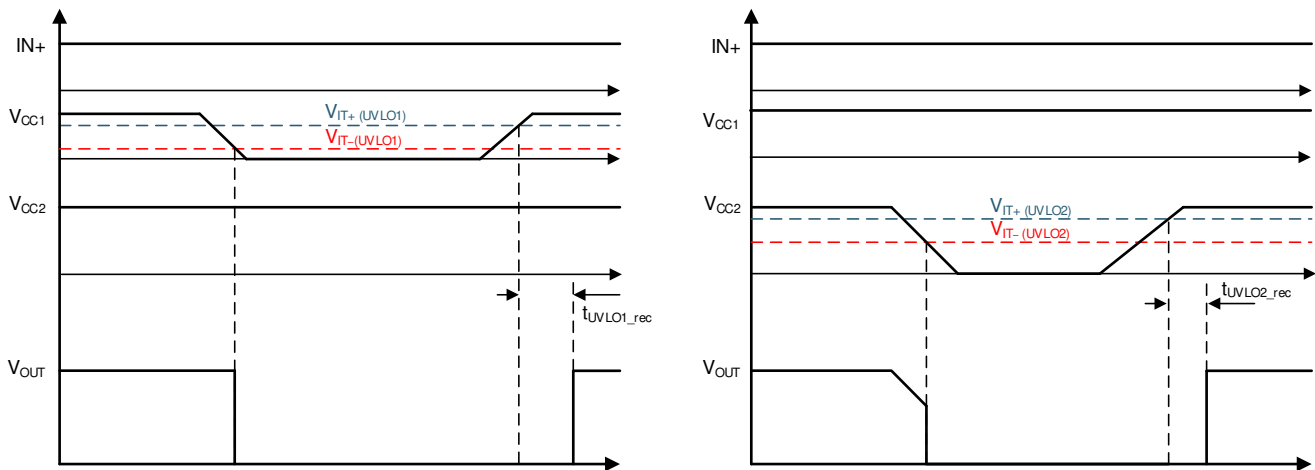
resistively held off by a pull-up resistor while the lower NMOS gate is tied to the driver output through a 500-kΩ resistor. In this configuration, the output is effectively clamped to the threshold voltage of the lower NMOS device, which is approximately 1.5 V when no bias power is available.

8.3.4.3 Short-Circuit Clamping

The short-circuit clamping function is used to clamp voltages at the driver output and pull the active Miller clamp pins slightly higher than the V_{CC2} voltage during short-circuit conditions. The short-circuit clamping function helps protect the IGBT or MOSFET gate from overvoltage breakdown or degradation. The short-circuit clamping function is implemented by adding a diode connection between the dedicated pins and the V_{CC2} pin inside the driver. The internal diodes can conduct up to 500-mA current for a duration of 10 μs and a continuous current of 20 mA. Use external Schottky diodes to improve current conduction capability as needed.

8.3.4.4 Active Miller Clamp

The active Miller-clamp function helps to prevent a false turn-on of the power switches caused by Miller current in applications where a unipolar power supply is used. The active Miller-clamp function is implemented by adding a low impedance path between the power-switch gate terminal and ground (V_{EE2}) to sink the Miller current. With the Miller-clamp function, the power-switch gate voltage is clamped to less than 2 V during the off state. [☒ 9-2](#) shows a typical application circuit of this function.

8.4 Device Functional Modes

[表 8-5](#) lists the functional modes for the UCC5350-Q1 assuming V_{CC1} and V_{CC2} are in the recommended range.

表 8-4. Function Table for UCC5350SB-Q1

IN+	IN-	OUTH	OUTL
Low	X	Hi-Z	Low
X	High	Hi-Z	Low
High	Low	High	High-Z

表 8-5. Function Table for UCC5350MC-Q1

IN+	IN-	OUT
Low	X	Low
X	High	Low
High	Low	High

8.4.1 ESD Structure

[☒ 8-9](#) shows the multiple diodes involved in the ESD protection components of the UCC5350-Q1 device. This provides pictorial representation of the absolute maximum rating for the device.



図 8-8. ESD Structure 'S' version



図 8-9. ESD Structure 'M' Version

9 Application and Implementation

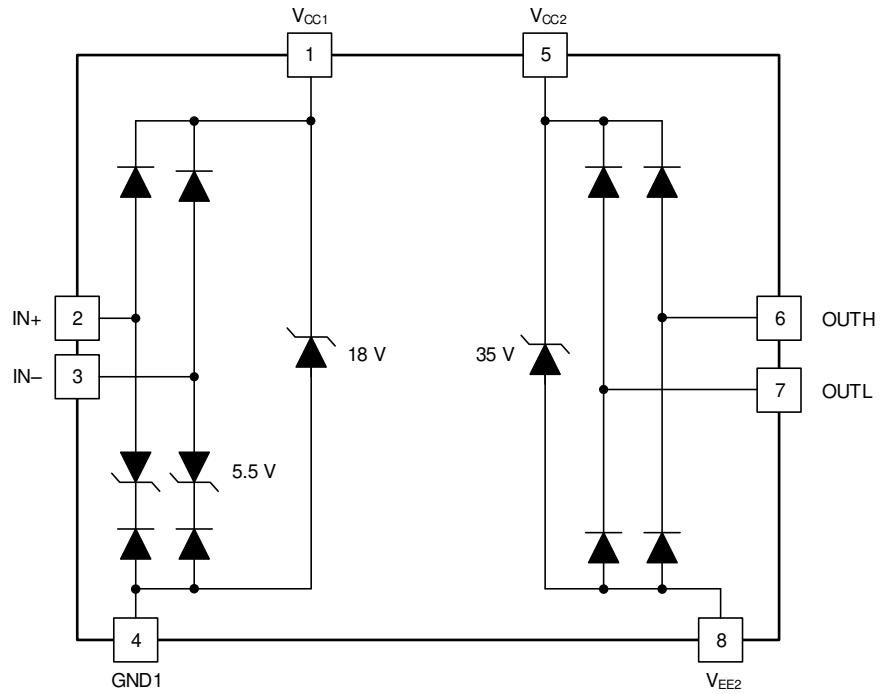
注

以下のアプリケーション情報は、TI の製品仕様に含まれるものではなく、TI ではその正確性または完全性を保証いたしません。個々の目的に対する製品の適合性については、お客様の責任で判断していただくことになります。お客様は自身の設計実装を検証しテストすることで、システムの機能を確認する必要があります。

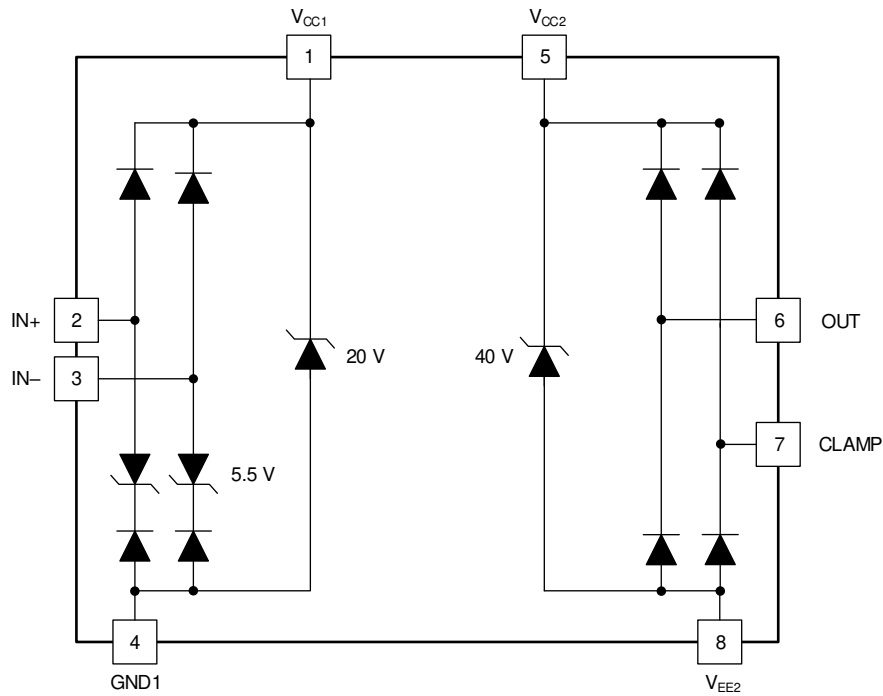
9.1 Application Information

The UCC5350-Q1 is a simple, isolated gate driver for power semiconductor devices, such as MOSFETs, IGBTs, or SiC MOSFETs. The family of devices is intended for use in applications such as motor control, solar inverters, switched-mode power supplies, and industrial inverters.

The UCC5350-Q1 has two pinout configurations, featuring split outputs and Miller clamp. The split outputs, OUTH and OUTL, are used to separately decouple the power transistor turn on and turn off commutations.

The M version features active Miller clamping, which can be used to prevent false turn-on of the power transistors induced by the Miller current. The device comes in an 8-pin D and 8-pin DWV package and has creepage, or clearance, of 4 mm and 8.5 mm, respectively, which is suitable for applications where basic or reinforced isolation is required. The UCC5350-Q1 offers a 5-A minimum drive current.

9.2 Typical Application

The circuits in [Figure 9-1](#) and [Figure 9-2](#) show a typical application for driving IGBTs.

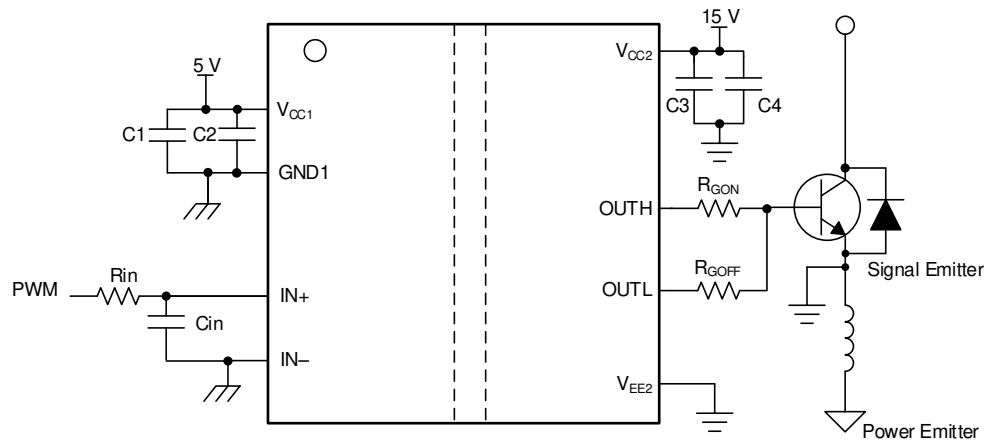

Copyright © 2017, Texas Instruments Incorporated

Figure 9-1. Typical Application Circuit for UCC5350SB-Q1 to Drive IGBT

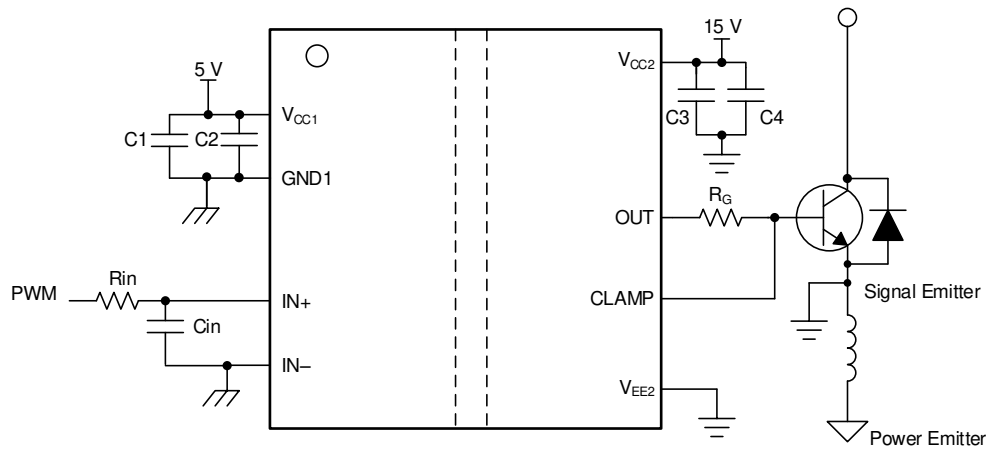

Copyright © 2017, Texas Instruments Incorporated

図 9-2. Typical Application Circuit for UCC5350MC-Q1 to Drive IGBT

9.2.1 Design Requirements

表 9-1. UCC5350-Q1 Design Requirements

PARAMETER	VALUE	UNIT
V_{CC1}	3.3	V
$V_{CC2} - V_{EE2}$	18	V
IN+	3.3	V
IN-	GND1	-
Switching frequency	150	kHz
Gate Charge of Power Device	126	nC

9.2.2 Detailed Design Procedure

9.2.2.1 Designing IN+ and IN- Input Filter

TI recommends that users avoid shaping the signals to the gate driver in an attempt to slow down (or delay) the signal at the output. However, a small input filter, R_{IN} - C_{IN} , can be used to filter out the ringing introduced by nonideal layout or long PCB traces.

Such a filter should use an R_{IN} resistor with a value from 0 Ω to 100 Ω and a C_{IN} capacitor with a value from 10 pF to 1000 pF. In the example, the selected value for R_{IN} is 51 Ω and C_{IN} is 33 pF, with a corner frequency of approximately 100 MHz.

When selecting these components, pay attention to the trade-off between good noise immunity and propagation delay.

9.2.2.2 Gate-Driver Output Resistor

The external gate-driver resistors, $R_{G(ON)}$ and $R_{G(OFF)}$ are used to:

1. Limit ringing caused by parasitic inductances and capacitances
2. Limit ringing caused by high voltage or high current switching dv/dt , di/dt , and body-diode reverse recovery
3. Fine-tune gate drive strength, specifically peak sink and source current to optimize the switching loss
4. Reduce electromagnetic interference (EMI)

The output stage has a pull-up structure consisting of a P-channel MOSFET and an N-channel MOSFET in parallel. The combined typical peak source current is 10 A for UCC5350-Q1. Use 式 1 to estimate the peak source current.

$$I_{OH} = \frac{V_{CC2} - V_{EE2}}{R_{NMOS} || R_{OH} + R_{GON} + R_{GFET_Int}} \quad (1)$$

where

- R_{ON} is the external turn-on resistance, which is 2.2 Ω in this example.
- R_{GFET_Int} is the power transistor internal gate resistance, found in the power transistor data sheet. We will assume 1.8 Ω for our example.
- I_{OH} is the typical peak source current which is the minimum value between 10 A, the gate-driver peak source current, and the calculated value based on the gate-drive loop resistance.

In this example, the peak source current is approximately 3.36 A as calculated in 式 2.

$$I_{OH} = \frac{V_{CC2} - V_{EE2}}{R_{NMOS} || R_{OH} + R_{GON} + R_{GFET_Int}} = \frac{18V}{1.54\Omega || 12\Omega + 2.2\Omega + 1.8\Omega} \approx 3.36A \quad (2)$$

Similarly, use 式 3 to calculate the peak sink current.

$$I_{OL} = \frac{V_{CC2} - V_{EE2}}{R_{OL} + R_{GOFF} + R_{GFET_Int}} \quad (3)$$

where

- R_{OFF} is the external turn-off resistance, which is 2.2 Ω in this example.
- I_{OL} is the typical peak sink current which is the minimum value between 10 A, the gate-driver peak sink current, and the calculated value based on the gate-drive loop resistance.

In this example, the peak sink current is the minimum value between 式 4 and 10 A.

$$I_{OL} = \frac{V_{CC2} - V_{EE2}}{R_{OL} + R_{GOFF} + R_{GFET_Int}} = \frac{18V}{0.26\Omega + 2.2\Omega + 1.8\Omega} \approx 4.23A \quad (4)$$

注

The estimated peak current is also influenced by PCB layout and load capacitance. Parasitic inductance in the gate-driver loop can slow down the peak gate-drive current and introduce overshoot and undershoot. Therefore, TI strongly recommends that the gate-driver loop should be minimized. Conversely, the peak source and sink current is dominated by loop parasitics when the load capacitance (C_{ISS}) of the power transistor is very small (typically less than 1 nF) because the rising and falling time is too small and close to the parasitic ringing period.

9.2.2.3 Estimate Gate-Driver Power Loss

The total loss, P_G , in the gate-driver subsystem includes the power losses (P_{GD}) of the UCC5350-Q1 device and the power losses in the peripheral circuitry, such as the external gate-drive resistor.

The P_{GD} value is the key power loss which determines the thermal safety-related limits of the UCC5350-Q1 device, and it can be estimated by calculating losses from several components.

The first component is the static power loss, P_{GDQ} , which includes quiescent power loss on the driver as well as driver self-power consumption when operating with a certain switching frequency. The P_{GDQ} parameter is measured on the bench with no load connected to the OUT pins at a given V_{CC1} , V_{CC2} , switching frequency, and ambient temperature. In this example, V_{CC1} is 3.3V and V_{CC2} is 18 V. The current on each power supply, with PWM switching from 0 V to 3.3 V at 150 kHz, is measured to be $I_{CC1} = 1.67$ mA and $I_{CC2} = 1.11$ mA. Therefore, use 式 5 to calculate P_{GDQ} .

$$P_{GDQ} = V_{CC1} \times I_{VCC1} + (V_{CC2} - V_{EE2}) \times I_{CC2} \approx 23.31mW \quad (5)$$

The second component is the switching operation loss, P_{GDO} , with a given load capacitance which the driver charges and discharges the load during each switching cycle. Use 式 6 to calculate the total dynamic loss from load switching, P_{GSW} .

$$P_{GSW} = (V_{CC2} - V_{EE2}) \times Q_G \times f_{SW} \quad (6)$$

where

- Q_G is the gate charge of the power transistor at V_{CC2} .

So, for this example application the total dynamic loss from load switching is approximately 340 mW as calculated in 式 7.

$$P_{GSW} = 18 \text{ V} \times 126 \text{ nC} \times 150 \text{ kHz} = 340 \text{ mW} \quad (7)$$

Q_G represents the total gate charge of the power transistor and is subject to change with different testing conditions. The UCC5350-Q1 gate-driver loss on the output stage, P_{GDO} , is part of P_{GSW} . P_{GDO} is equal to P_{GSW} if the external gate-driver resistance and power-transistor internal resistance are 0Ω , and all the gate driver-loss will be dissipated inside the UCC5350-Q1. If an external turn-on and turn-off resistance exists, the total loss is distributed between the gate driver pull-up/down resistance, external gate resistance, and power-transistor internal resistance. Importantly, the pull-up/down resistance is a linear and fixed resistance if the source/sink current is not saturated to 10 A, however, it will be non-linear if the source/sink current is saturated. The gate driver loss will be estimated in the case in which it is not saturated as given in 式 8.

$$P_{GDO} = \frac{P_{GSW}}{2} \left(\frac{R_{OH} \parallel R_{NMOS}}{R_{OH} \parallel R_{NMOS} + R_{GON} + R_{GFET_Int}} + \frac{R_{OL}}{R_{OL} + R_{GOFF} + R_{GFET_Int}} \right) \quad (8)$$

In this design example, all the predicted source and sink currents are less than 10 A, therefore, use 式 9 to estimate the gate-driver loss.

$$P_{GDO} = \frac{340 \text{ mW}}{2} \left(\frac{12 \Omega \parallel 1.54 \Omega}{12 \Omega \parallel 1.54 \Omega + 2.2 \Omega + 1.8 \Omega} + \frac{0.26 \Omega}{0.26 \Omega + 2.2 \Omega + 1.8 \Omega} \right) \approx 53.66 \text{ mW} \quad (9)$$

where

- $V_{OUTH/L(t)}$ is the gate-driver OUT pin voltage during the turnon and turnoff period. In cases where the output is saturated for some time, this value can be simplified as a constant-current source (10 A at turnon and turnoff) charging or discharging a load capacitor. Then, the $V_{OUTH/L(t)}$ waveform will be linear and the T_{R_Sys} and T_{F_Sys} can be easily predicted.

Use 式 10 to calculate the total gate-driver loss dissipated in the UCC5350-Q1 gate driver, P_{GD} .

$$P_{GD} = P_{GDQ} + P_{GDO} = 25.31 \text{ mW} + 53.66 \text{ mW} = 78.97 \text{ mW} \quad (10)$$

9.2.2.4 Estimating Junction Temperature

Use the equation below to estimate the junction temperature (T_J) of the UCC5350-Q1 family.

$$T_J = T_C + \Psi_{JT} \times P_{GD} \quad (11)$$

where

- T_C is the UCC5350-Q1 case-top temperature measured with a thermocouple or some other instrument.
- Ψ_{JT} is the junction-to-top characterization parameter from the Thermal Information table.

Using the junction-to-top characterization parameter (Ψ_{JT}) instead of the junction-to-case thermal resistance ($R_{\theta JC}$) can greatly improve the accuracy of the junction temperature estimation. The majority of the thermal energy of most ICs is released into the PCB through the package leads, whereas only a small percentage of the total energy is released through the top of the case (where thermocouple measurements are usually conducted). The $R_{\theta JC}$ resistance can only be used effectively when most of the thermal energy is released through the case, such as with metal packages or when a heat sink is applied to an IC package. In all other cases, use of $R_{\theta JC}$ will inaccurately estimate the true junction temperature. The Ψ_{JT} parameter is experimentally derived by assuming that the dominant energy leaving through the top of the IC will be similar in both the testing environment and the application environment. As long as the recommended layout guidelines are observed, junction temperature estimations can be made accurately to within a few degrees Celsius.

9.2.3 Selecting V_{CC1} and V_{CC2} Capacitors

Bypass capacitors for the V_{CC1} and V_{CC2} supplies are essential for achieving reliable performance. TI recommends choosing low-ESR and low-ESL, surface-mount, multi-layer ceramic capacitors (MLCC) with sufficient voltage ratings, temperature coefficients, and capacitance tolerances.

注

DC bias on some MLCCs will impact the actual capacitance value. For example, a 25-V, 1- μ F X7R capacitor is measured to be only 500 nF when a DC bias of 15- V_{DC} is applied.

9.2.3.1 Selecting a V_{CC1} Capacitor

A bypass capacitor connected to the V_{CC1} pin supports the transient current required for the primary logic and the total current consumption, which is only a few milliamperes. Therefore, a 50-V MLCC with over 100 nF is recommended for this application. If the bias power-supply output is located a relatively long distance from the V_{CC1} pin, a tantalum or electrolytic capacitor with a value greater than 1 μ F should be placed in parallel with the MLCC.

9.2.3.2 Selecting a V_{CC2} Capacitor

A 50-V, 10- μ F MLCC and a 50-V, 0.22- μ F MLCC are selected for the C_{VCC2} capacitor. If the bias power supply output is located a relatively long distance from the V_{CC2} pin, a tantalum or electrolytic capacitor with a value greater than 10 μ F should be used in parallel with C_{VCC2} .

9.2.3.3 Application Circuits with Output Stage Negative Bias

When parasitic inductances are introduced by nonideal PCB layout and long package leads (such as TO-220 and TO-247 type packages), ringing in the gate-source drive voltage of the power transistor could occur during high di/dt and dv/dt switching. If the ringing is over the threshold voltage, unintended turn-on and shoot-through could occur. Applying a negative bias on the gate drive is a popular way to keep such ringing below the threshold. A few examples of implementing negative gate-drive bias follow.

 **9-3** shows the first example with negative bias turn-off on the output using a Zener diode on the isolated power-supply output stage. The negative bias is set by the Zener diode voltage. If the isolated power supply is equal to 20 V, the turn-off voltage is -5.1 V and the turn-on voltage is 20 V $- 5.1$ V ≈ 15 V.

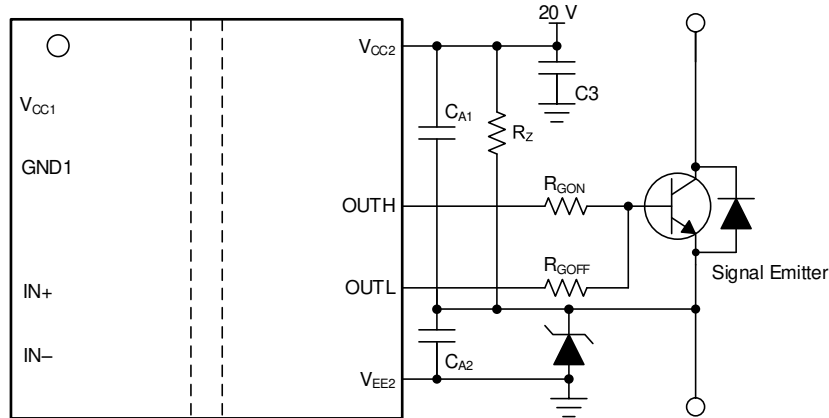

Copyright © 2017, Texas Instruments Incorporated

图 9-3. Negative Bias With Zener Diode on Iso-Bias Power-Supply Output

图 9-4 shows another example which uses two supplies (or single-input, double-output power supply). The power supply across V_{CC2} and the emitter determines the positive drive output voltage and the power supply across V_{EE2} and the emitter determines the negative turn-off voltage. This solution requires more power supplies than the first example, however, it provides more flexibility when setting the positive and negative rail voltages.



图 9-4. Negative Bias With Two Iso-Bias Power Supplies

9.2.4 Application Curve

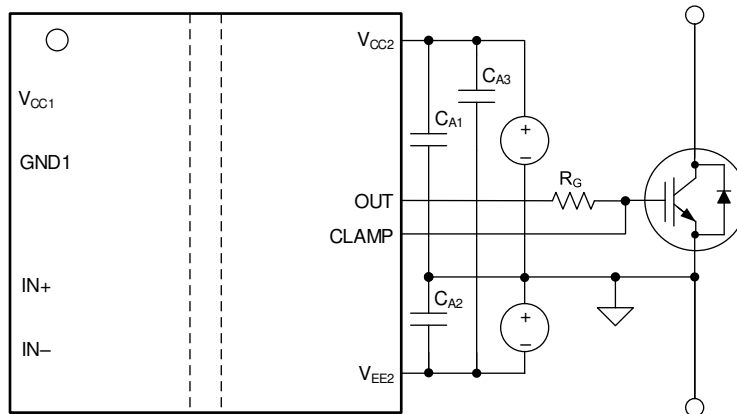

図 9-5. PWM Input and Gate Voltage Waveform

10 Power Supply Recommendations

The recommended input supply voltage (V_{CC1}) for the UCC5350-Q1 device is from 3 V to 15 V. The lower limit of the range of output bias-supply voltage (V_{CC2}) is determined by the internal UVLO protection feature of the device. The V_{CC1} and V_{CC2} voltages should not fall below their respective UVLO thresholds for normal operation, or else the gate-driver outputs can become clamped low for more than 50 μs by the UVLO protection feature. For more information on UVLO, see [セクション 8.3.4.1](#). The higher limit of the V_{CC2} range depends on the maximum gate voltage of the power device that is driven by the UCC5350-Q1 device, and should not exceed the recommended maximum V_{CC2} of 33 V. A local bypass capacitor should be placed between the V_{CC2} and V_{EE2} pins, with a value of 220-nF to 10- μF for device biasing. TI recommends placing an additional 100-nF capacitor in parallel with the device biasing capacitor for high frequency filtering. Both capacitors should be positioned as close to the device as possible. Low-ESR, ceramic surface-mount capacitors are recommended. Similarly, a bypass capacitor should also be placed between the V_{CC1} and GND1 pins. Given the small amount of current drawn by the logic circuitry within the input side of the UCC5350-Q1 device, this bypass capacitor has a minimum recommended value of 100 nF.

11 Layout

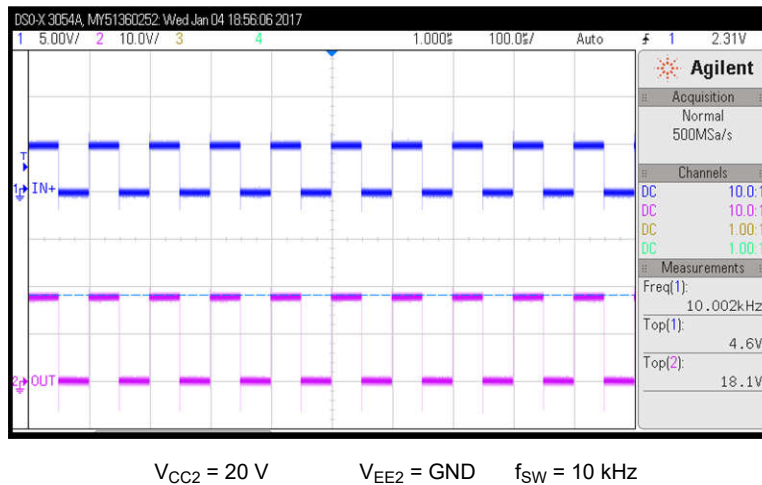
11.1 Layout Guidelines

Designers must pay close attention to PCB layout to achieve optimum performance for the UCC5350-Q1. Some key guidelines are:

- Component placement:
 - Low-ESR and low-ESL capacitors must be connected close to the device between the V_{CC1} and GND1 pins and between the V_{CC2} and V_{EE2} pins to bypass noise and to support high peak currents when turning on the external power transistor.
 - To avoid large negative transients on the V_{EE2} pins connected to the switch node, the parasitic inductances between the source of the top transistor and the source of the bottom transistor must be minimized.
- Grounding considerations:
 - Limiting the high peak currents that charge and discharge the transistor gates to a minimal physical area is essential. This limitation decreases the loop inductance and minimizes noise on the gate terminals of the transistors. The gate driver must be placed as close as possible to the transistors.
- High-voltage considerations:

- To ensure isolation performance between the primary and secondary side, avoid placing any PCB traces or copper below the driver device. A PCB cutout or groove is recommended in order to prevent contamination that may compromise the isolation performance.
- Thermal considerations:
 - A large amount of power may be dissipated by the UCC5350-Q1 if the driving voltage is high, the load is heavy, or the switching frequency is high (for more information, see [セクション 9.2.2.3](#)). Proper PCB layout can help dissipate heat from the device to the PCB and minimize junction-to-board thermal impedance (θ_{JB}).
 - Increasing the PCB copper connecting to the V_{CC2} and V_{EE2} pins is recommended, with priority on maximizing the connection to V_{EE2} . However, the previously mentioned high-voltage PCB considerations must be maintained.
 - If the system has multiple layers, TI also recommends connecting the V_{CC2} and V_{EE2} pins to internal ground or power planes through multiple vias of adequate size. These vias should be located close to the IC pins to maximize thermal conductivity. However, keep in mind that no traces or coppers from different high voltage planes are overlapping.

11.2 Layout Example

☒ 11-1 shows a PCB layout example with the signals and key components labeled. The UCC5390ECDWV evaluation module (EVM) is given as an example, available in the same DWV package as the UCC5350-Q1. The UCC5390EC has a split emitter versus Miller clamp so although the layout is not exactly the same, general guidelines and practices still apply. The evaluation board can be configured for the Miller clamp version, as well, as described in the [UCC5390ECDWV Isolated Gate Driver Evaluation Module User's Guide](#).

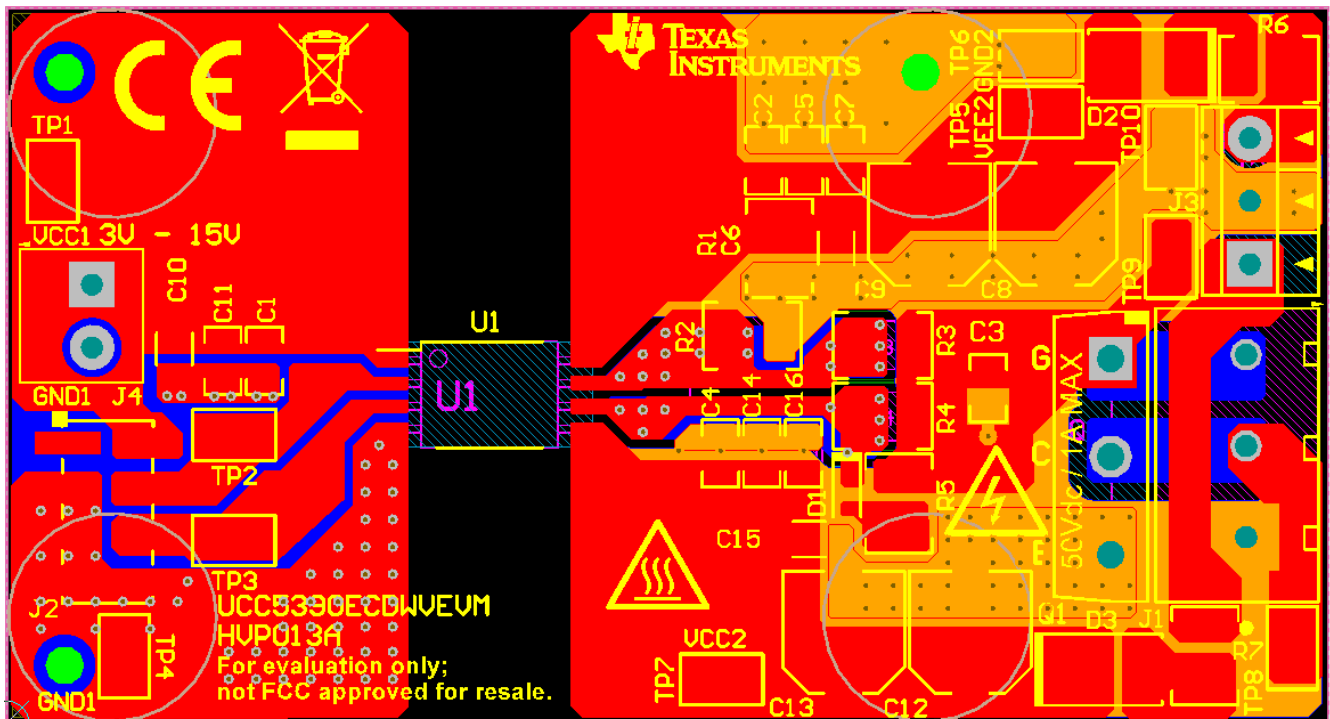

A. No PCB traces or copper are located between the primary and secondary side, which ensures isolation performance.

☒ 11-1. Layout Example

☒ 11-2 and ☒ 11-3 show the top and bottom layer traces and copper.



図 11-2. Top-Layer Traces and Copper



図 11-3. Bottom-Layer Traces and Copper (Flipped)

図 11-4 shows the 3D layout of the top view of the PCB.

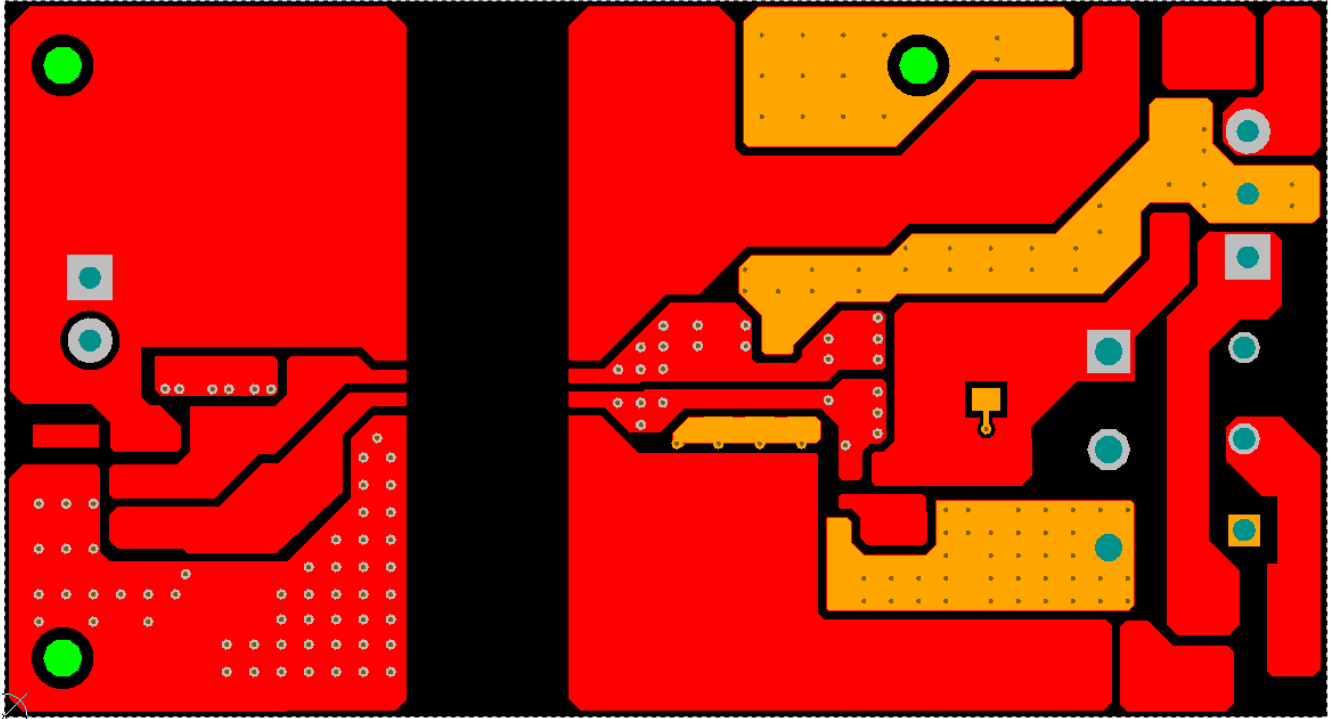

11-4. 3-D PCB View

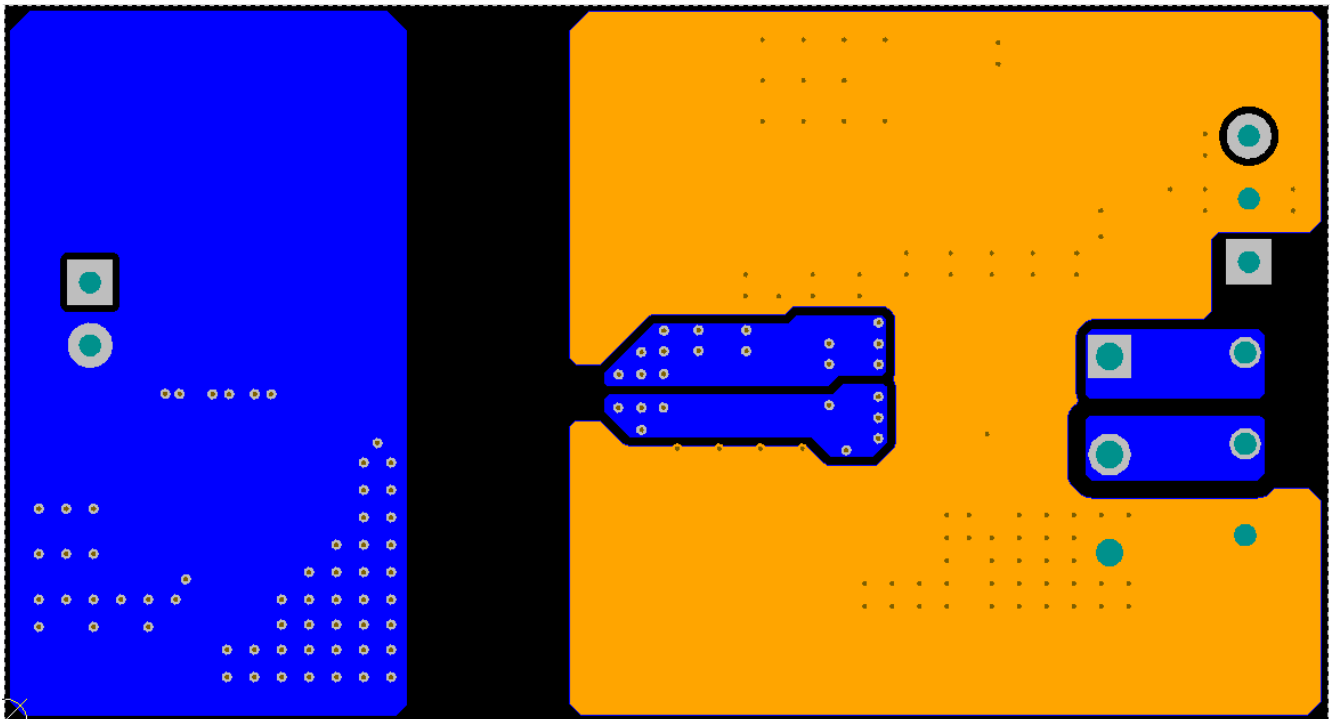
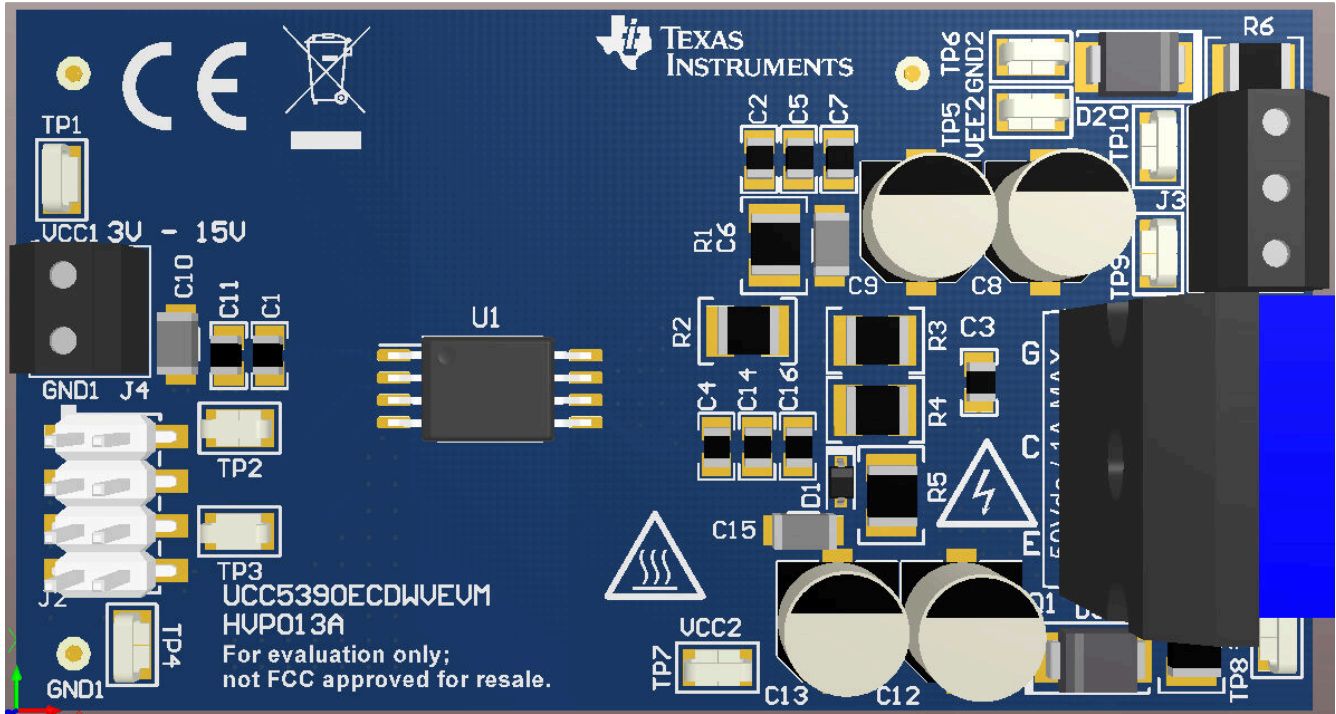
11.3 PCB Material

Use standard FR-4 UL94V-0 printed circuit board. This PCB is preferred over cheaper alternatives because of lower dielectric losses at high frequencies, less moisture absorption, greater strength and stiffness, and the self-extinguishing flammability-characteristics.

11-5 shows the recommended layer stack.

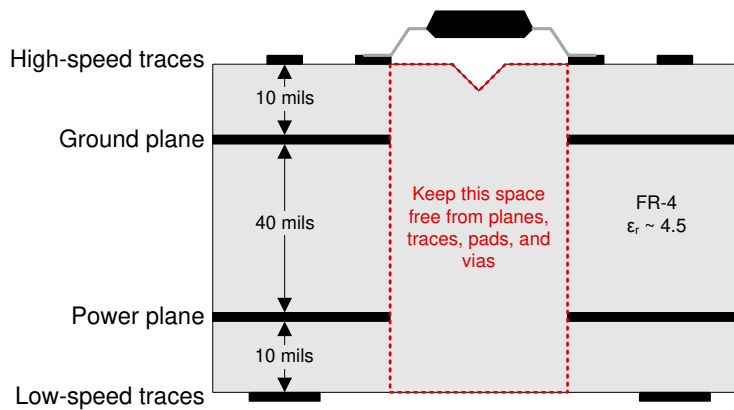

11-5. Recommended Layer Stack

12 Device and Documentation Support

12.1 Device Support

12.1.1 サード・パーティ製品に関する免責事項

サード・パーティ製品またはサービスに関するテキサス・インスツルメンツの出版物は、単独またはテキサス・インスツルメンツの製品、サービスと一緒に提供される場合に関係なく、サード・パーティ製品またはサービスの適合性に関する是認、サード・パーティ製品またはサービスの是認の表明を意味するものではありません。

12.2 Documentation Support

12.2.1 Related Documentation

For related documentation see the following:

- Texas Instruments, [Digital Isolator Design Guide](#)
- Texas Instruments, [Isolation Glossary](#)
- Texas Instruments, [SN6501 Transformer Driver for Isolated Power Supplies data sheet](#)
- Texas Instruments, [SN6505A Low-Noise 1-A Transformer Drivers for Isolated Power Supplies data sheet](#)
- Texas Instruments, [UCC5390ECDWV Isolated Gate Driver Evaluation Module user's guide](#)
- Texas Instruments, [UCC53x0xD Evaluation Module user's guide](#)

12.3 Certifications

UL Online Certifications Directory, ["FPPT2.E181974 Nonoptical Isolating Devices - Component" Certificate Number: 20170718-E181974](#),

12.4 ドキュメントの更新通知を受け取る方法

ドキュメントの更新についての通知を受け取るには、www.tij.co.jp のデバイス製品フォルダを開いてください。[通知] をクリックして登録すると、変更されたすべての製品情報に関するダイジェストを毎週受け取ることができます。変更の詳細については、改訂されたドキュメントに含まれている改訂履歴をご覧ください。

12.5 サポート・リソース

テキサス・インスツルメンツ E2E™ サポート・フォーラムは、エンジニアが検証済みの回答と設計に関するヒントをエキスパートから迅速かつ直接得ることができる場所です。既存の回答を検索したり、独自の質問をしたりすることで、設計に必要な支援を迅速に得ることができます。

リンクされているコンテンツは、各寄稿者により「現状のまま」提供されるものです。これらはテキサス・インスツルメンツの仕様を構成するものではなく、必ずしもテキサス・インスツルメンツの見解を反映したものではありません。テキサス・インスツルメンツの[使用条件](#)を参照してください。

12.6 Trademarks

テキサス・インスツルメンツ E2E™ is a trademark of Texas Instruments.
すべての商標は、それぞれの所有者に帰属します。

12.7 静電気放電に関する注意事項



この IC は、ESD によって破損する可能性があります。テキサス・インスツルメンツは、IC を取り扱う際には常に適切な注意を払うことを推奨します。正しい取り扱いおよび設置手順に従わない場合、デバイスを破損するおそれがあります。

ESD による破損は、わずかな性能低下からデバイスの完全な故障まで多岐にわたります。精密な IC の場合、パラメータがわずかに変化するだけで公表されている仕様から外れる可能性があるため、破損が発生しやすくなっています。

12.8 用語集

テキサス・インスツルメンツ用語集

この用語集には、用語や略語の一覧および定義が記載されています。

13 Revision History

資料番号末尾の英字は改訂を表しています。その改訂履歴は英語版に準じています。

Changes from Revision D (August 2022) to Revision E (February 2024) Page

- Changed CTI and Material Group values in insulation specifications and added table note.....6

Changes from Revision C (June 2022) to Revision D (August 2022) Page

- UCC5350SB-Q1 を「事前情報」から「量産データ」に変更..... 1

Changes from Revision B (June 2020) to Revision C (June 2022) Page

- UCC5350SBQDRQ1 デバイスの事前情報を追加..... 1
- 追加 [セクション 4](#)3
- Added the UCC5350SB device to [セクション 5](#) 4
- Added SB-Q1 D package power ratings.....6
- Added SB-Q1 insulation specs.....6
- Added the UL certificate number for the D package.....9
- Added the UL certificate number for the DWV package.....9
- Added SB-Q1 D package safety limiting values.....9
- Added SB-Q1 parameters..... 10
- Added minimum pulse width specs..... 11
- Added [表 8-4](#) 23
- Added SB-Q1 ESD figure 23
- Added typical application circuit for SB-Q1..... 25

14 Mechanical, Packaging, and Orderable Information

The following pages include mechanical, packaging, and orderable information. This information is the most current data available for the designated devices. This data is subject to change without notice and revision of this document. For browser-based versions of this data sheet, refer to the left-hand navigation.

重要なお知らせと免責事項

テキサス・インスツルメンツは、技術データと信頼性データ(データシートを含みます)、設計リソース(リファレンス デザインを含みます)、アプリケーションや設計に関する各種アドバイス、Web ツール、安全性情報、その他のリソースを、欠陥が存在する可能性のある「現状のまま」提供しており、商品性および特定目的に対する適合性の黙示保証、第三者の知的財産権の非侵害保証を含むいかなる保証も、明示的または黙示的にかかわらず拒否します。

これらのリソースは、テキサス・インスツルメンツ製品を使用する設計の経験を積んだ開発者への提供を意図したものです。(1) お客様のアプリケーションに適したテキサス・インスツルメンツ製品の選定、(2) お客様のアプリケーションの設計、検証、試験、(3) お客様のアプリケーションに該当する各種規格や、その他のあらゆる安全性、セキュリティ、規制、または他の要件への確実な適合に関する責任を、お客様のみが単独で負うものとします。

上記の各種リソースは、予告なく変更される可能性があります。これらのリソースは、リソースで説明されているテキサス・インスツルメンツ製品を使用するアプリケーションの開発の目的でのみ、テキサス・インスツルメンツはその使用をお客様に許諾します。これらのリソースに関して、他の目的で複製することや掲載することは禁止されています。テキサス・インスツルメンツや第三者の知的財産権のライセンスが付与されている訳ではありません。お客様は、これらのリソースを自身で使用した結果発生するあらゆる申し立て、損害、費用、損失、責任について、テキサス・インスツルメンツおよびその代理人を完全に補償するものとし、テキサス・インスツルメンツは一切の責任を拒否します。

テキサス・インスツルメンツの製品は、[テキサス・インスツルメンツの販売条件](#)、または [ti.com](https://www.ti.com) やかかるテキサス・インスツルメンツ製品の関連資料などのいずれかを通じて提供する適用可能な条項の下で提供されています。テキサス・インスツルメンツがこれらのリソースを提供することは、適用されるテキサス・インスツルメンツの保証または他の保証の放棄の拡大や変更を意味するものではありません。

お客様がいかなる追加条項または代替条項を提案した場合でも、テキサス・インスツルメンツはそれらに異議を唱え、拒否します。

郵送先住所: Texas Instruments, Post Office Box 655303, Dallas, Texas 75265
Copyright © 2024, Texas Instruments Incorporated

PACKAGING INFORMATION

Orderable part number	Status (1)	Material type (2)	Package Pins	Package qty Carrier	RoHS (3)	Lead finish/ Ball material (4)	MSL rating/ Peak reflow (5)	Op temp (°C)	Part marking (6)
PUCC5350MCQDWVQ1	Obsolete	Preproduction	SOIC (DWV) 8	-	-	Call TI	Call TI	-40 to 125	
UCC5350MCQDRQ1	Active	Production	SOIC (D) 8	2500 LARGE T&R	Yes	Call TI Nipdau	Level-2-260C-1 YEAR	-40 to 125	5350Q
UCC5350MCQDRQ1.A	Active	Production	SOIC (D) 8	2500 LARGE T&R	Yes	NIPDAU	Level-2-260C-1 YEAR	-40 to 125	5350Q
UCC5350MCQDWVRQ1	Active	Production	SOIC (DWV) 8	1000 LARGE T&R	Yes	NIPDAU	Level-3-260C-168 HR	-40 to 125	5350MCQ
UCC5350MCQDWVRQ1.A	Active	Production	SOIC (DWV) 8	1000 LARGE T&R	Yes	NIPDAU	Level-3-260C-168 HR	-40 to 125	5350MCQ
UCC5350SBQDRQ1	Active	Production	SOIC (D) 8	2500 LARGE T&R	Yes	Call TI Nipdau	Level-3-260C-168 HR	-40 to 125	5350Q
UCC5350SBQDRQ1.A	Active	Production	SOIC (D) 8	2500 LARGE T&R	Yes	NIPDAU	Level-3-260C-168 HR	-40 to 125	5350Q

(1) **Status:** For more details on status, see our [product life cycle](#).

(2) **Material type:** When designated, preproduction parts are prototypes/experimental devices, and are not yet approved or released for full production. Testing and final process, including without limitation quality assurance, reliability performance testing, and/or process qualification, may not yet be complete, and this item is subject to further changes or possible discontinuation. If available for ordering, purchases will be subject to an additional waiver at checkout, and are intended for early internal evaluation purposes only. These items are sold without warranties of any kind.

(3) **RoHS values:** Yes, No, RoHS Exempt. See the [TI RoHS Statement](#) for additional information and value definition.

(4) **Lead finish/Ball material:** Parts may have multiple material finish options. Finish options are separated by a vertical ruled line. Lead finish/Ball material values may wrap to two lines if the finish value exceeds the maximum column width.

(5) **MSL rating/Peak reflow:** The moisture sensitivity level ratings and peak solder (reflow) temperatures. In the event that a part has multiple moisture sensitivity ratings, only the lowest level per JEDEC standards is shown. Refer to the shipping label for the actual reflow temperature that will be used to mount the part to the printed circuit board.

(6) **Part marking:** There may be an additional marking, which relates to the logo, the lot trace code information, or the environmental category of the part.

Multiple part markings will be inside parentheses. Only one part marking contained in parentheses and separated by a "-" will appear on a part. If a line is indented then it is a continuation of the previous line and the two combined represent the entire part marking for that device.

Important Information and Disclaimer:The information provided on this page represents TI's knowledge and belief as of the date that it is provided. TI bases its knowledge and belief on information provided by third parties, and makes no representation or warranty as to the accuracy of such information. Efforts are underway to better integrate information from third parties. TI has taken and continues to take reasonable steps to provide representative and accurate information but may not have conducted destructive testing or chemical analysis on incoming materials and chemicals. TI and TI suppliers consider certain information to be proprietary, and thus CAS numbers and other limited information may not be available for release.

In no event shall TI's liability arising out of such information exceed the total purchase price of the TI part(s) at issue in this document sold by TI to Customer on an annual basis.

OTHER QUALIFIED VERSIONS OF UCC5350-Q1 :

- Catalog : [UCC5350](#)

NOTE: Qualified Version Definitions:

- Catalog - TI's standard catalog product

TAPE AND REEL INFORMATION

QUADRANT ASSIGNMENTS FOR PIN 1 ORIENTATION IN TAPE

*All dimensions are nominal

Device	Package Type	Package Drawing	Pins	SPQ	Reel Diameter (mm)	Reel Width W1 (mm)	A0 (mm)	B0 (mm)	K0 (mm)	P1 (mm)	W (mm)	Pin1 Quadrant
UCC5350MCQDRQ1	SOIC	D	8	2500	330.0	12.4	6.4	5.2	2.1	8.0	12.0	Q1
UCC5350MCQDWVRQ1	SOIC	DWV	8	1000	330.0	16.4	12.05	6.15	3.3	16.0	16.0	Q1
UCC5350SBQDRQ1	SOIC	D	8	2500	330.0	12.4	6.4	5.2	2.1	8.0	12.0	Q1

TAPE AND REEL BOX DIMENSIONS

*All dimensions are nominal

Device	Package Type	Package Drawing	Pins	SPQ	Length (mm)	Width (mm)	Height (mm)
UCC5350MCQDRQ1	SOIC	D	8	2500	353.0	353.0	32.0
UCC5350MCQDWVRQ1	SOIC	DWV	8	1000	350.0	350.0	43.0
UCC5350SBQDRQ1	SOIC	D	8	2500	353.0	353.0	32.0

PACKAGE OUTLINE

DWV0008A



SOIC - 2.8 mm max height

SOIC

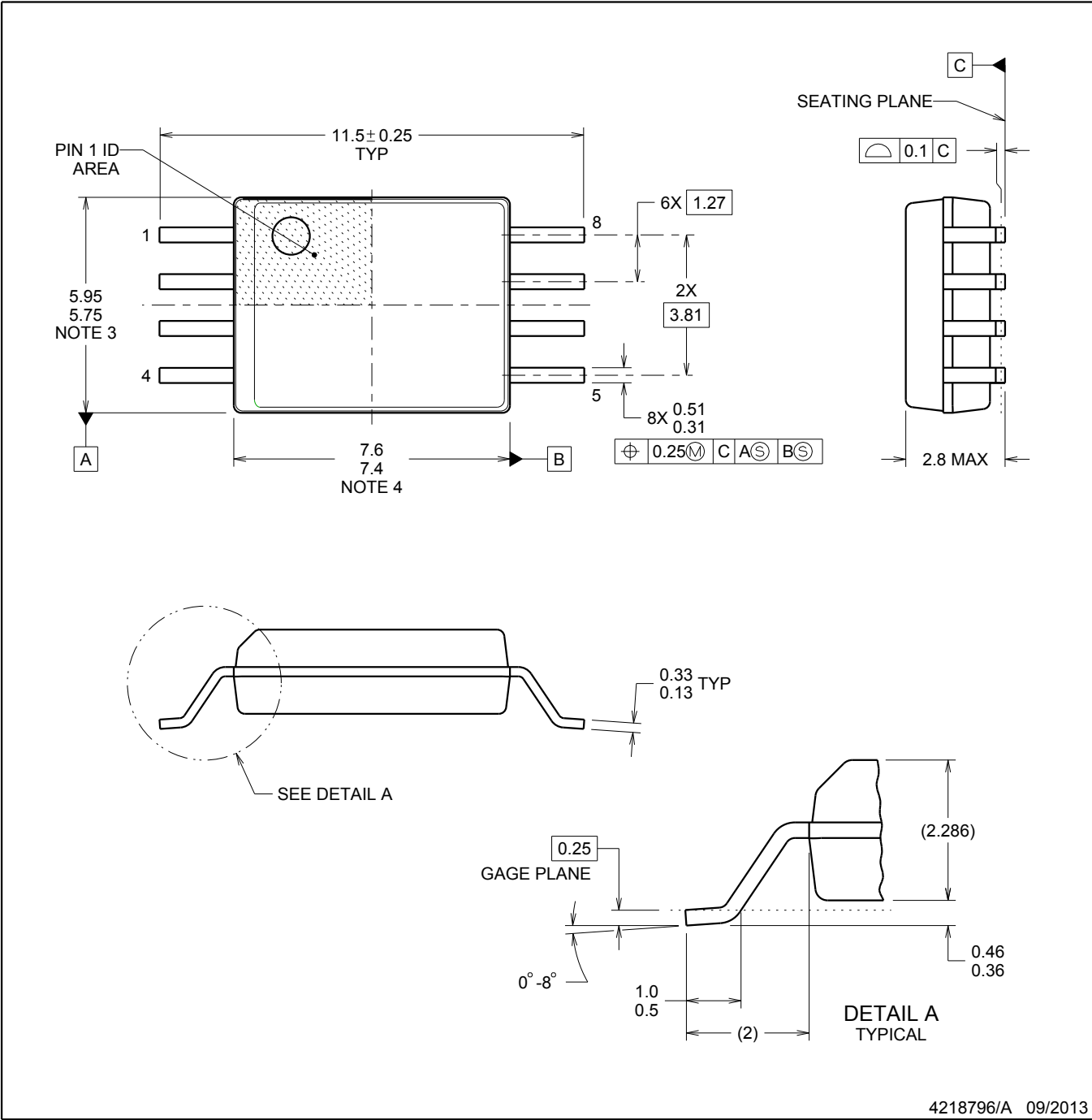

4218796/A 09/2013

NOTES:

1. All linear dimensions are in millimeters. Dimensions in parenthesis are for reference only. Dimensioning and tolerancing per ASME Y14.5M.
2. This drawing is subject to change without notice.
3. This dimension does not include mold flash, protrusions, or gate burrs. Mold flash, protrusions, or gate burrs shall not exceed 0.15 mm, per side.
4. This dimension does not include interlead flash. Interlead flash shall not exceed 0.25 mm, per side.

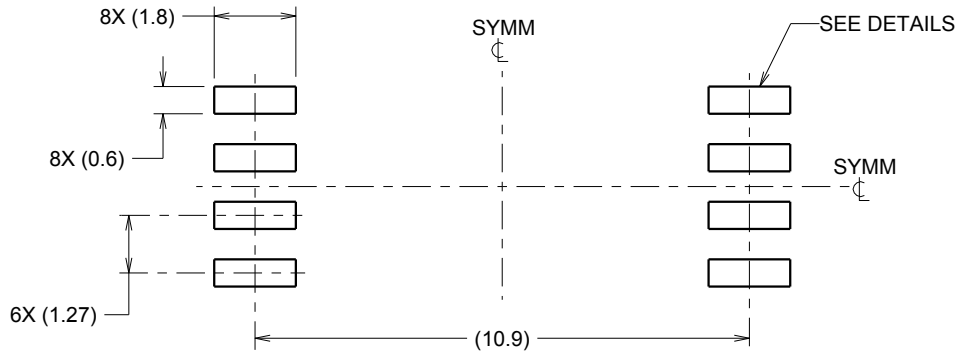

LAND PATTERN EXAMPLE
 9.1 mm NOMINAL CLEARANCE/CREEPAGE
 SCALE:6X

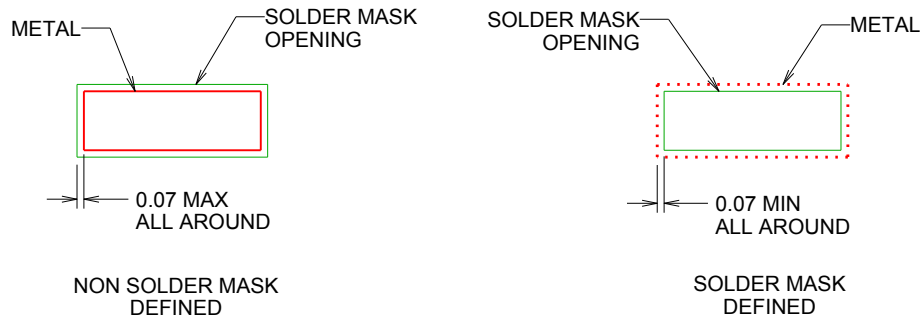

SOLDER MASK DETAILS

4218796/A 09/2013

NOTES: (continued)

- 5. Publication IPC-7351 may have alternate designs.
- 6. Solder mask tolerances between and around signal pads can vary based on board fabrication site.

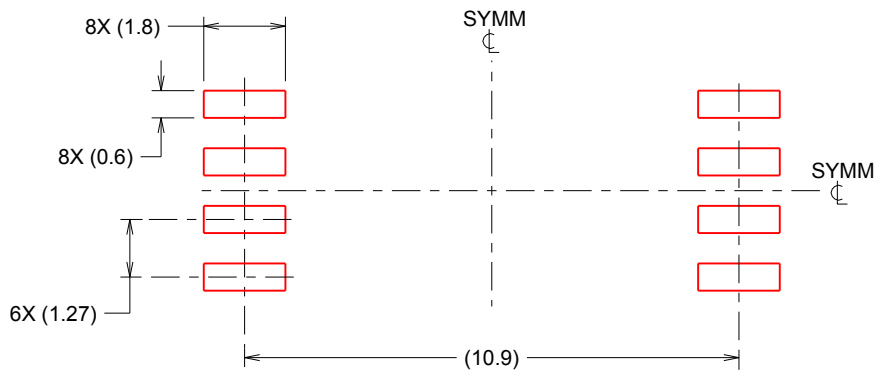

SOLDER PASTE EXAMPLE
 BASED ON 0.125 mm THICK STENCIL
 SCALE:6X

4218796/A 09/2013

NOTES: (continued)

- 7. Laser cutting apertures with trapezoidal walls and rounded corners may offer better paste release. IPC-7525 may have alternate design recommendations.
- 8. Board assembly site may have different recommendations for stencil design.



D0008A

PACKAGE OUTLINE

SOIC - 1.75 mm max height

SMALL OUTLINE INTEGRATED CIRCUIT



4214825/C 02/2019

NOTES:

- Linear dimensions are in inches [millimeters]. Dimensions in parenthesis are for reference only. Controlling dimensions are in inches. Dimensioning and tolerancing per ASME Y14.5M.
- This drawing is subject to change without notice.
- This dimension does not include mold flash, protrusions, or gate burrs. Mold flash, protrusions, or gate burrs shall not exceed $.006$ [0.15] per side.
- This dimension does not include interlead flash.
- Reference JEDEC registration MS-012, variation AA.

EXAMPLE BOARD LAYOUT

D0008A

SOIC - 1.75 mm max height

SMALL OUTLINE INTEGRATED CIRCUIT



LAND PATTERN EXAMPLE
 EXPOSED METAL SHOWN
 SCALE:8X



SOLDER MASK DETAILS

4214825/C 02/2019

NOTES: (continued)

- 6. Publication IPC-7351 may have alternate designs.
- 7. Solder mask tolerances between and around signal pads can vary based on board fabrication site.

EXAMPLE STENCIL DESIGN

D0008A

SOIC - 1.75 mm max height

SMALL OUTLINE INTEGRATED CIRCUIT



SOLDER PASTE EXAMPLE
BASED ON .005 INCH [0.125 MM] THICK STENCIL
SCALE:8X

4214825/C 02/2019

NOTES: (continued)

8. Laser cutting apertures with trapezoidal walls and rounded corners may offer better paste release. IPC-7525 may have alternate design recommendations.
9. Board assembly site may have different recommendations for stencil design.

重要なお知らせと免責事項

TI は、技術データと信頼性データ(データシートを含みます)、設計リソース(リファレンス デザインを含みます)、アプリケーションや設計に関する各種アドバイス、Web ツール、安全性情報、その他のリソースを、欠陥が存在する可能性のある「現状のまま」提供しており、商品性および特定目的に対する適合性の黙示保証、第三者の知的財産権の非侵害保証を含むいかなる保証も、明示的または黙示的にかかわらず拒否します。

これらのリソースは、TI 製品を使用する設計の経験を積んだ開発者への提供を意図したものです。(1) お客様のアプリケーションに適した TI 製品の選定、(2) お客様のアプリケーションの設計、検証、試験、(3) お客様のアプリケーションに該当する各種規格や、その他のあらゆる安全性、セキュリティ、規制、または他の要件への確実な適合に関する責任を、お客様のみが単独で負うものとし、

上記の各種リソースは、予告なく変更される可能性があります。これらのリソースは、リソースで説明されている TI 製品を使用するアプリケーションの開発の目的でのみ、TI はその使用をお客様に許諾します。これらのリソースに関して、他の目的で複製することや掲載することは禁止されています。TI や第三者の知的財産権のライセンスが付与されている訳ではありません。お客様は、これらのリソースを自身で使用した結果発生するあらゆる申し立て、損害、費用、損失、責任について、TI およびその代理人を完全に補償するものとし、TI は一切の責任を拒否します。

TI の製品は、[TI の販売条件](#)、[TI の総合的な品質ガイドライン](#)、[ti.com](#) または TI 製品などに関連して提供される他の適用条件に従い提供されます。TI がこれらのリソースを提供することは、適用される TI の保証または他の保証の放棄の拡大や変更を意味するものではありません。TI がカスタム、またはカスタマー仕様として明示的に指定していない限り、TI の製品は標準的なカタログに掲載される汎用機器です。

お客様がいかなる追加条項または代替条項を提案する場合も、TI はそれらに異議を唱え、拒否します。

Copyright © 2026, Texas Instruments Incorporated

最終更新日 : 2025 年 10 月