

ABSTRACT

The LP87745-Q1 device is designed to meet the power management requirements of the AWR and IWR MMICs in various automotive and industrial radar applications. The device has three step-down DC/DC converters, a 5 V boost converter and a 1.8 V/3.3 V LDO. The LDO is powered from the boost and intended for xWR and peripheral devices IO supply. The device is controlled by an SPI serial interface and by enable signal. The step-down DC/DC converters support programmable switching frequency of 17.6 MHz, 8.8 MHz or 4.4 MHz and have low noise across wide frequency range which enables LDO-free power solution with minimal or no additional passive filtering. LP87745-Q1 device offers flexible external component selection to optimize the solution in terms of performance or cost. The features of the device target safety-relevant applications with system-safety requirements up to ASIL-C level.

This user's guide provides instructions to power up and evaluate LP87745-Q1 device using the LP877451Q1EVM evaluation module (EVM) and software user interface (LP87745-Q1 GUI). By default LP877451Q1EVM has LP877451A1RXVRQ1 device OTP version (17.6 MHz, Low noise use case BOM), but this EVM can also be used to evaluate another OTP device from LP8774x-Q1 product family.



CAUTION
Hot surface.
Contact may cause burns.
Do not touch!

Table of Contents

1 Top View with Basic External Connections	2
2 Input, Output Voltages, and Load Current Requirements	3
3 Jumpers and connectors	4
3.1 Test Points.....	6
4 Getting Started	8
4.1 GUI.....	8
4.2 GUI Installation and working with GUI.....	8
5 Watchdog	12
6 Schematics, Layout and BOM	14
6.1 Schematic Diagram.....	15
6.2 PCB Layer Diagram.....	18
6.3 Components List.....	18
7 Revision History	22

List of Figures

Figure 1-1. EVM Top-View Diagram With Basic Connections and Default Jumpers.....	2
Figure 4-1. GUI Front Page.....	9
Figure 4-2. GUI Configuration Page.....	10
Figure 4-3. GUI Register Map Page.....	11
Figure 5-1. Watchdog Sequence in Q&A Mode.....	12
Figure 5-2. GUI Watchdog Validation Configuration	13
Figure 5-3. GUI Watchdog Configuration	13
Figure 6-1. PMIC Schematic.....	15
Figure 6-2. Preregulator Schematic.....	16
Figure 6-3. MCU Schematic.....	17

Figure 6-4. Layout of Top Layer, Layer 1..... 18
 Figure 6-5. Layout of Ground layer 1, Layer 2..... 18
 Figure 6-6. Layout of Signal Layer 1, Layer 3..... 18
 Figure 6-7. Layout of Signal Layer 2, Layer 4..... 18
 Figure 6-8. Layout of Ground Layer 2, Layer 5..... 18
 Figure 6-9. Layout of Bottom Layer, Layer 6..... 18

List of Tables

Table 2-1. Input and Output Voltages, and Load Current Requirements..... 3
 Table 3-1. Terminal Blocks..... 4
 Table 3-2. Configuration Jumpers..... 4
 Table 3-3. Test Points on the EVM..... 6
 Table 4-1. Jumper Connections for Powering the EVM..... 8
 Table 6-1. Components list..... 18

Trademarks

All trademarks are the property of their respective owners.

1 Top View with Basic External Connections

Figure 1-1 shows the top-view diagram of the EVM along with basic connections. By default, EVM is configured to power up through VBAT supply through onboard 12 V VIN to 3.3 V VOUT pre-regulator. EVM can also be powered through external 3.3 V supply or through USB port. Please refer to Table 3-2 for the right jumper configuration for each power-supply input.

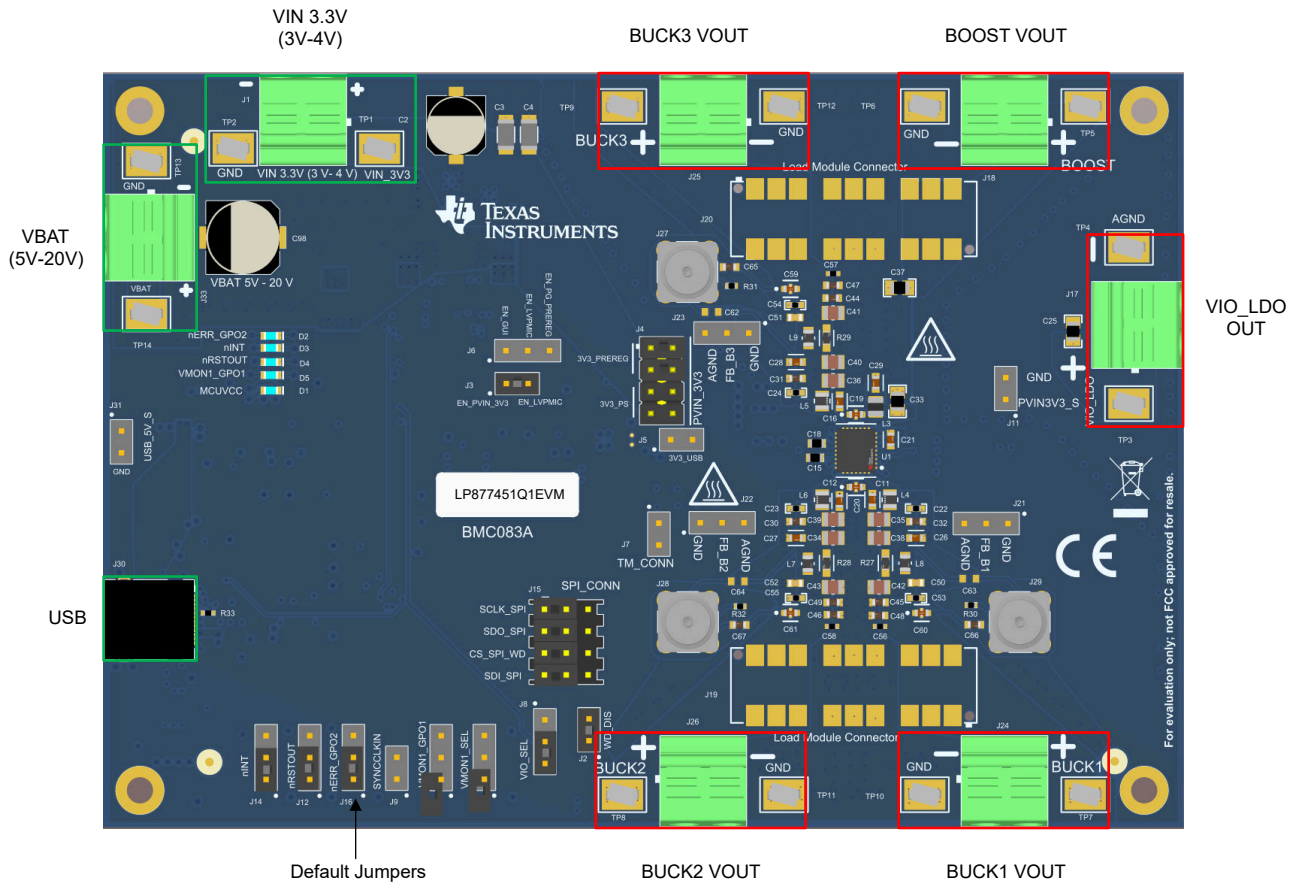

Figure 1-1. EVM Top-View Diagram With Basic Connections and Default Jumpers

2 Input, Output Voltages, and Load Current Requirements

LP87745-Q1 device works with 3.3 V input supply and supply is internally monitored for undervoltage (UV) and overvoltage (OV) conditions and hence keep the input supply voltage within 3.3 V +/- 8 % to avoid input supply UV/OV detection. Input power plane to the PMIC has option for additional filtering using L1 and L2 on the bottom side of the PCB.

- If the VBAT/preregulator path is used (default configuration), input supply to the device is already regulated to 3.3 V.
- If external 3.3 V supply is used, ensure that input supply voltage is always within the recommended voltage range and drop across supply path must be considered.
- If EVM is configured to work with USB supply, regulators should not be loaded.

[Table 2-1](#) lists the input and output voltage for each regulator and their maximum load-current requirements. Refer LP87745-Q1 device data sheet for more information about device electrical characteristics and its features.

Table 2-1. Input and Output Voltages, and Load Current Requirements

Regulator Name	Input Supply Voltage at PMIC Supply Pin	Output Voltage	Maximum Load Current
BUCK1	3.04 V - 3.56 V	1.8 V	3 A
BUCK2	3.04 V - 3.56 V	1.0 V	3 A
BUCK3	3.04 V - 3.56 V	1.2 V	3 A
BOOST	3.04 V - 3.56 V	5 V	0.3 A
VIO_LDO	5 V (Generated from BOOST)	3.3 V	0.150 A

If all the regulators are loaded with maximum load current simultaneously, PMIC and PCB can become hot. Make sure that PMIC junction temperature does not exceed 150 °C.

3 Jumpers and connectors

LP877451Q1EVM has many terminal blocks, jumpers and test points to offer certain flexibility to help users to verify the EVM according to their application conditions. However, the EVM is pre-configured with default jumper settings and users can power up the regulators without the need of jumper modifications. Setting these jumpers correctly for the correct function of the EVM is important. [Table 3-1](#) lists all the terminal blocks on the EVM and [Table 3-2](#) lists the jumpers and their functionality. All the terminal blocks are marked with polarity and Pin 1 of test points / jumpers are marked with white dot for identification purpose. To understand more about the jumper functionality, see the schematic diagrams in [Section 6.1](#).

Table 3-1. Terminal Blocks

Terminal Block Number	Terminal Block Name	Description
J1	VIN 3.3V	3.3 V External Input Voltage
J17	VIO_LDO	Terminal block for VIO_LDO Output
J18	BOOST	Terminal block for BOOST Output
J24	BUCK1	Terminal block for BUCK1 Output
J25	BUCK3	Terminal block for BUCK3 Output
J26	BUCK2	Terminal block for BUCK2 Output
J30	J30	USB Connector
J33	VBAT	5 V - 20 V Input

Table 3-2. Configuration Jumpers

Jumper/Connector Number	Jumper/Connector Name	Configuration	Description
J2	WD_DIS	Closed (Default)	Pull down resistor in CS_SPI pin enabled which will disable Q&A watchdog during the PMIC power up. For this to be effective, USB cable should not be connected to the EVM when the PMIC is powered up. If USB cable is connected before PMIC is powered up, USB MCU will drive this pin high (through CS_SPI_WD at J15) during the startup
		Open	Q&A watchdog not disabled during the PMIC power up
J3	EN_PVIN_3V3	Closed (Default)	Connects PMIC ENABLE pin to PVIN_Bx pins (PVIN_3V3) through a pull up resistor and device gets enabled as soon as 3.3 V is generated/applied
		Open	If PMIC needs to be enabled through USB/GUI or through pre-regulator PGOOD signal, then this jumper must be kept open
J4	PVIN_3V3	Option 1: Pins 1/3 and 2/4 3V3_PREREG (Default)	PVIN_3V3 connected to preregulator output. J4-Option-2 must be open and J5 must be open.
		Option 2: Pins 5/7 and 6/8 3V3_PS	PVIN_3V3 connected to external 3.3V supply (J1). J4-Option-1 must be open and J5 must be open.

Table 3-2. Configuration Jumpers (continued)

Jumper/Connector Number	Jumper/Connector Name	Configuration	Description
J5	3V3_USB	Open (Default)	Either option from J4 must be used.
		Closed	PMIC input supply (PVIN_3V3) is generated from USB supply. J4 jumpers must be open if this jumper is closed.
J6	EN_LVPMIC	Option 1: Open (Default)	PMIC Enable signal from 3.3 V Input. J3 must be closed
		Option 2: Pins 1 and 2	PMIC Enable signal path from GUI interface. J3 must be open if this Option is used
		Option 3: Pins 2 and 3	PMIC Enable signal path from pre-regulator PGOOD signal. J3 must be open if this Option is used
J8	VIO_SEL	Pins 1 and 2	3.3 V supply generated from USB supply
		Pins 2 and 3 (Default)	3.3 V VIO supply generated from PMIC VIO_LDO
J9	SYNCCLKIN	Pins 1 and 2	SYNCCLKIN pin connected to MCU clock port (used for testing external clock input signal)
J10	VMON1_SEL	Pins 1 and 2 (Default: open)	VMON1 reference voltage generated from voltage divider on VIO supply
		Pins 2 and 3 (Default: open)	VMON1 voltage taken from BUCK1 (1.8 V) output
J12	nRSTOUT	Pins 1 and 2 (Default)	Connects PMIC nRSTOUT signal to MCU port directly
		Pins 2 and 3	Connects PMIC nRSTOUT signal to MCU port through level shifter (series resistors must be mounted if this option is used)
J13	VMON1_GPO1	Pins 1 and 2 (Default: open)	Connects PMIC VMON1 signal to MCU port directly
		Pins 2 and 3 (Default: open)	Connects PMIC VMON1 signal to MCU port through level shifter (series resistors must be mounted if this option is used)
J14	nINT	Pins 1 and 2 (Default)	Connects PMIC nINT signal to MCU port directly
		Pins 2 and 3	Connects PMIC nINT signal to MCU port through level shifter (series resistors must be mounted if this option is used)

Table 3-2. Configuration Jumpers (continued)

Jumper/Connector Number	Jumper/Connector Name	Configuration	Description
J15	SCLK_SPI	Pins 1 and 2 (Default)	Connects PMIC SCLK_SPI signal to MCU SCLK_SPI port directly
		Pins 2 and 3	Connects PMIC SCLK_SPI signal to MCU SCLK_SPI port through a level shifter (series resistors need to be mounted if this option is used)
	SDO_SPI	Pins 1 and 2 (Default)	Connects PMIC SDO_SPI signal to MCU SDO_SPI port directly
		Pins 2 and 3	Connects PMIC SDO_SPI signal to MCU SDO_SPI port through a level shifter (series resistors need to be mounted if this option is used)
	CS_SPI_WD	Pins 1 and 2 (Default)	Connects PMIC CS_SPI signal to MCU CS_SPI port directly
		Pins 2 and 3	Connects PMIC CS_SPI signal to MCU CS_SPI port through a level shifter (series resistors must be mounted if this option is used)
	SDI_SPI	Pins 1 and 2 (Default)	Connects PMIC SDI_SPI signal to MCU SDI_SPI port directly
		Pins 2 and 3	Connects PMIC SDI_SPI signal to MCU SDI_SPI port through a level shifter (series resistors need to be mounted if this option is used)
J16	nERR_GPO2	Pins 1 and 2 (Default)	Connects PMIC nERR_GPO signal to MCU port directly
		Pins 2 and 3	Connects PMIC nERR_GPO2 signal to MCU port through level shifter (series resistors must be mounted if this option is used)

3.1 Test Points

Table 3-3 lists all the available connectors on the EVM.

Table 3-3. Test Points on the EVM

Connector Number	Connector Name	Description
J11	PVIN3V3_S	Test point to measure the input voltage of the PMIC
J19	Load Module Connector	Connector placeholder for PMICLOADBOARDEVM for doing load transient testing
J20	Load Module Connector	Connector placeholder for PMICLOADBOARDEVM for doing load transient testing
J21	FB_B1	Test point to measure the BUCK1 feedback signal
J22	FB_B2	Test point to measure the BUCK2 feedback signal
J23	FB_B3	Test point to measure the BUCK3 feedback signal
J27	J27	SMA connector for BUCK3 noise measurement
J28	J28	SMA connector for BUCK2 noise measurement

Table 3-3. Test Points on the EVM (continued)

Connector Number	Connector Name	Description
J29	J29	SMA connector for BUCK1 noise measurement
J31	USB_5V_S	Test point to measure 5 V supply from USB cable

4 Getting Started

In its default configuration, connecting +12 V and GND to the VBAT terminal block (J33) will power up the EVM. While loading the regulators, ensure that input power supply has sufficient current source capabilities to avoid supply voltage collapse due to current limiting.

EVM can also be powered through external 3.3 V input supply or through USB power by modifying jumper settings on the EVM. [Table 4-1](#) describes the jumper settings for different supply options.

Table 4-1. Jumper Connections for Powering the EVM

Power Source	Input Voltage Range	Jumpers
VBAT	5 V - 20 V	Both 3V3_PREREG jumpers in J4 (Default option). Leave J5 open.
Vin 3.3V	3.1 V - 3.5 V	Remove 3V3_PREREG jumpers on J4 and place them on 3V3_PS position on J4. With this configuration, do not apply power to VBAT terminal. Leave J5 open.
USB	5 V USB cable	J5, 3V3_USB. With this option, jumpers on J4 must be removed.

The LP877451Q1EVM does not require any specific power-down sequence. The EVM can be powered down by turning off the power supply or by toggling the EN Pin off in the GUI, if the GUI control signal is used to enable/disable the device. Refer to [Table 3-2](#) and [GUI section](#) for more information about configuring jumpers and using GUI.

4.1 GUI

Texas Instruments provides a simple to use LP87745-Q1 GUI tool to enable, configure, and evaluate the various features of the LP87745-Q1 device on the EVM. Please refer to the GUI *README.md* file in the GUI tool's *Help->View README.md* tab for a more detailed description of this tool.

The GUI will run on most PC platforms and requires a USB port for connecting the EVM to the host computer. The EVM USB connector is type-C and a type-A to type-C cable is provided along with the EVM to connect to the host computer. EVM will get automatically connected to the GUI after the USB cable is connected and manual assignment of COM port is not necessary. If *Hardware not Connected* displays on the bottom left of the GUI, clicking *Click to connect to hardware* icon next to it will re-establish the connection. The GUI uses the ACtrl COM port which can be found from the device manager of the operating system.

4.2 GUI Installation and working with GUI

The GUI can be found [here](#) and it can be run in browser or it can be installed to the computer. [Figure 4-1](#) shows the default interface of GUI. Please refer to the *README.md* file in the GUI tool for a complete guide on how to use the tool.

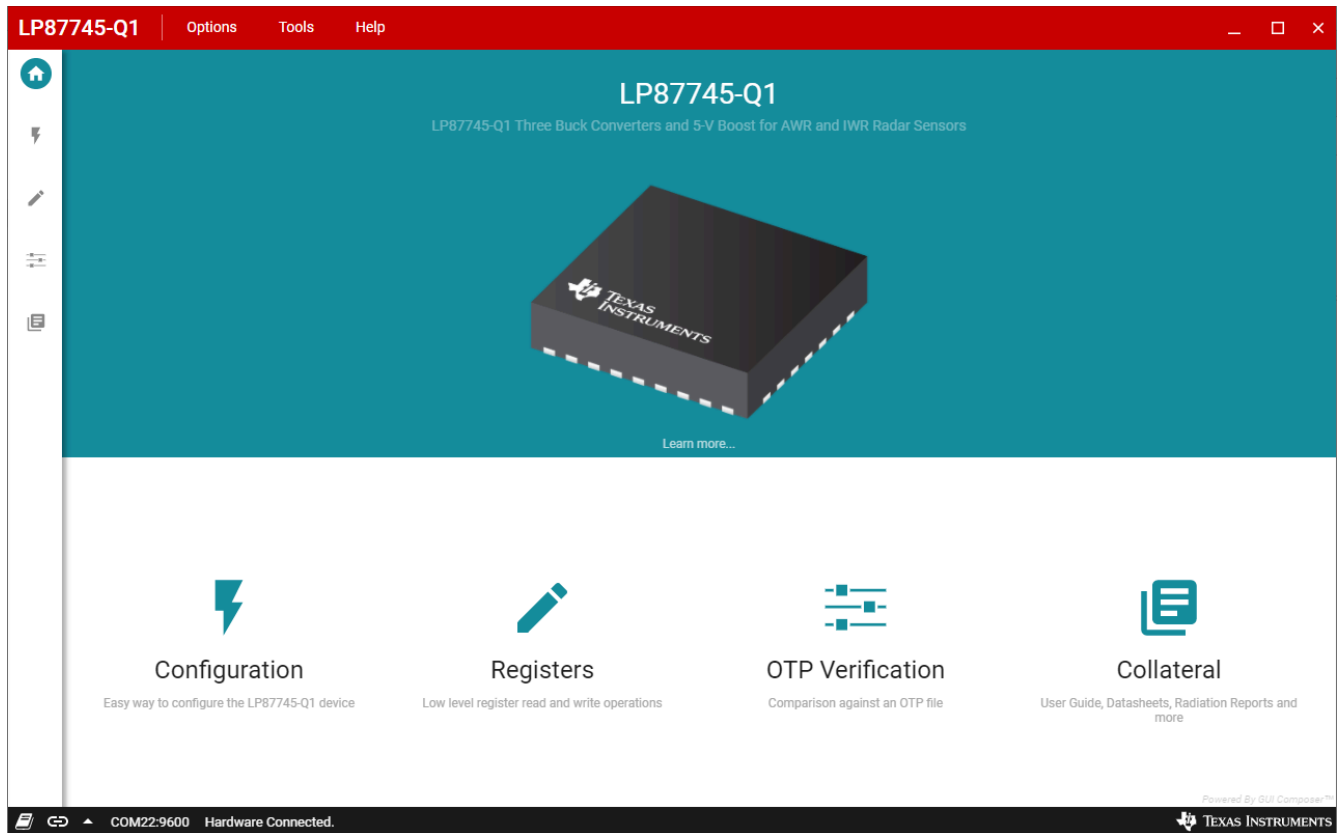

Figure 4-1. GUI Front Page

The EVM can be configured in the configuration page shown in [Figure 4-2](#). By default, all the configuration registers are locked and CRC protected. Clicking the *Unlock registers* check box on the Configuration Page will automatically write REGISTER_LOCK_STATUS = 0x9B to unlock the configuration registers for write operation. CRC can be disabled by writing CONFIG_CRC_EN = 0h through Console window (Options → Show Console) or GUI Register Map Page. For example, output voltages, startup and shutdown delays and peak current limits can be changed for each buck converter.

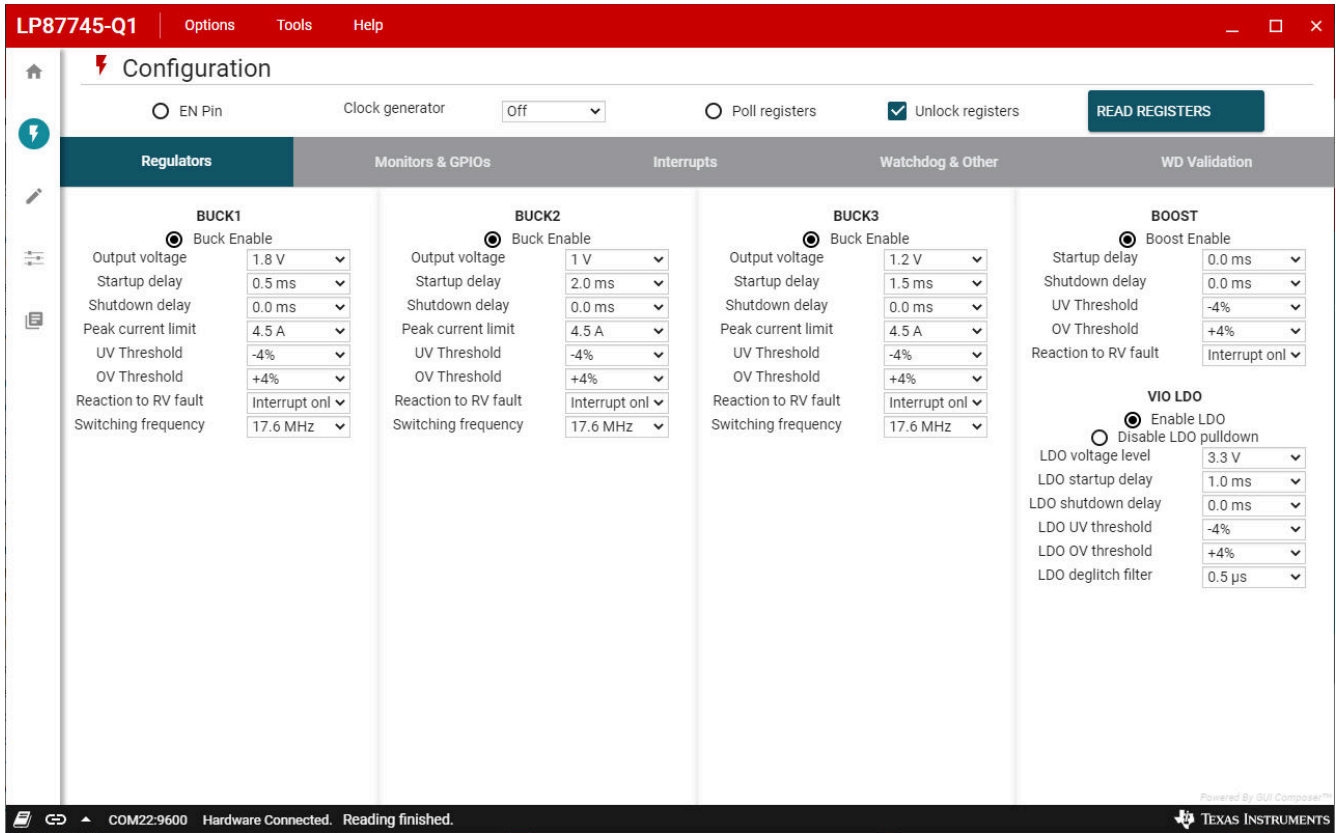

Figure 4-2. GUI Configuration Page

In the register map page shown in [Figure 4-3](#), registers can be read or written to.

LP87745-Q1 | Options Tools Help

Register Map

Auto Read: Off

READ REGISTER READ ALL REGISTERS WRITE REGISTER WRITE ALL REGISTERS Immediate Write

Search Registers by name or address (0x...) Search Bitfields Show Bits

Register Name	Address	Value	Bits									
			7	6	5	4	3	2	1	0		
▼ DEVICE												
DEV_REV	0x01	0x96	1	0	0	1	0	1	1	0		
NVM_CODE_1	0x02	0x00	0	0	0	0	0	0	0	0		
NVM_CODE_2	0x03	0x01	0	0	0	0	0	0	0	0	1	
FSM_COMMAND_REG	0x05	0x00	0	0	0	0	0	0	0	0	0	
BLOCK_EN_CTRL	0x06	0xDF	1	1	0	1	1	1	1	1		
GPO_CTRL	0x07	0x00									0	
RECOV_CNT_CONTROL	0x08	0x00								0	0	
ESM_START_REG	0x09	0x00									0	
REGISTER_LOCK	0x0A	0x00									0	
WD_ANSWER_REG	0x0F	0x00	0	0	0	0	0	0	0	0	0	
WD_ENABLE_REG	0x10	0x03								1	1	
WD_MODE_REG	0x11	0x00							0	0	0	
BUCK1_VOUT	0x12	0x2D			1	0	1	1	0	1		
BUCK2_VOUT	0x13	0x05			0	0	0	1	0	1		
BUCK3_VOUT	0x14	0x0F			0	0	1	1	1	1		
VMON1_PG_LEVEL	0x15	0x2D			1	0	1	1	0	1		
BUCK1_MON_CONF	0x16	0x56	0	1	0	1	0	1	1	0		
BUCK2_MON_CONF	0x17	0x56	0	1	0	1	0	1	1	0		
BUCK3_MON_CONF	0x18	0x56	0	1	0	1	0	1	1	0		
BOOST_MON_CONF	0x19	0x50	0	1	0	1	0	0	0	0		

FIELD VIEW

DEV_REV

DEVICE / DEV_REV / TI_DEVICE_ID[7:0]

0x96

COM22:9600 Hardware Connected. TEXAS INSTRUMENTS

Figure 4-3. GUI Register Map Page

5 Watchdog

This section provides the basic overview of the SPI based Q&A watchdog algorithm implemented on the EVM. Please refer LP87745-Q1 device data sheet for more detailed information about device watchdog functionality. This watchdog requires specific SPI messages from the host MCU in specific time intervals to detect correct operation of the MCU. On the EVM, MSP432 MCU is used as a host MCU.

During operation, the device provides a 4-bit question for the MCU and the MCU calculates the required 32-bit answer. This answer is split into four answer bytes: Answer-3, Answer-2, Answer-1 and Answer-0. The MCU writes these answer bytes one byte at a time into WD_ANSWER[7:0] from the SPI interface.

A good event occurs when the MCU sends the correct answer-bytes calculated for the current question in the correct watchdog window and in the correct sequence. This sequence is visualized in [Figure 5-1](#)

A bad event occurs when one of the events that follows occur:

- The MCU sends the correct answer-bytes, but not in the correct watchdog window.
- The MCU sends incorrect answer-bytes.
- The MCU returns correct answer-bytes, but in the incorrect sequence.

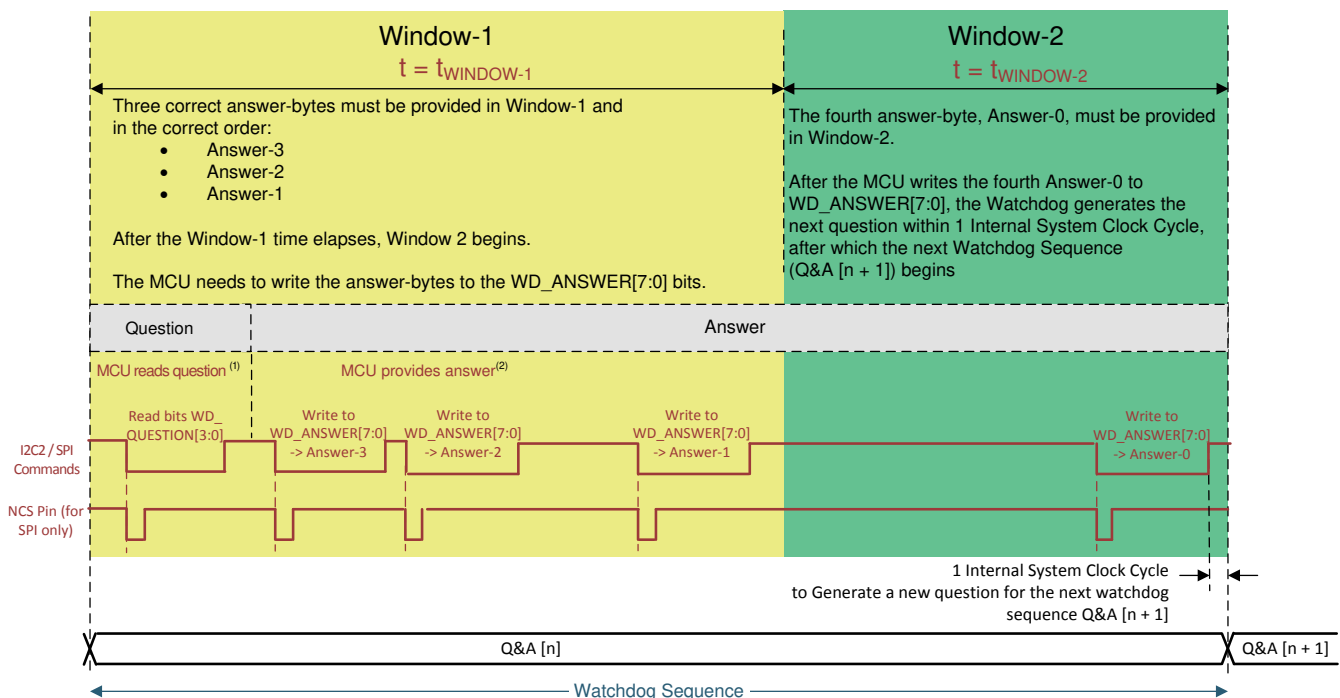

Figure 5-1. Watchdog Sequence in Q&A Mode

In GUI, there are two sections in configuration tab for watchdog configurability. [Figure 5-2](#) illustrates the watchdog validation section in GUI, where the delays between the WD Answers can be configured and watchdog status for different interrupts and errors can be observed. And if required status can be cleared through clear buttons available next to the each status. In the other watchdog configuration section, watchdog can be enabled or disabled along with other watchdog configurable parameters as shown in [Figure 5-3](#). For further information on watchdog configuration, refer to the data sheet of LP8774x-Q1 [SNVSB E7](#) for watchdog section.

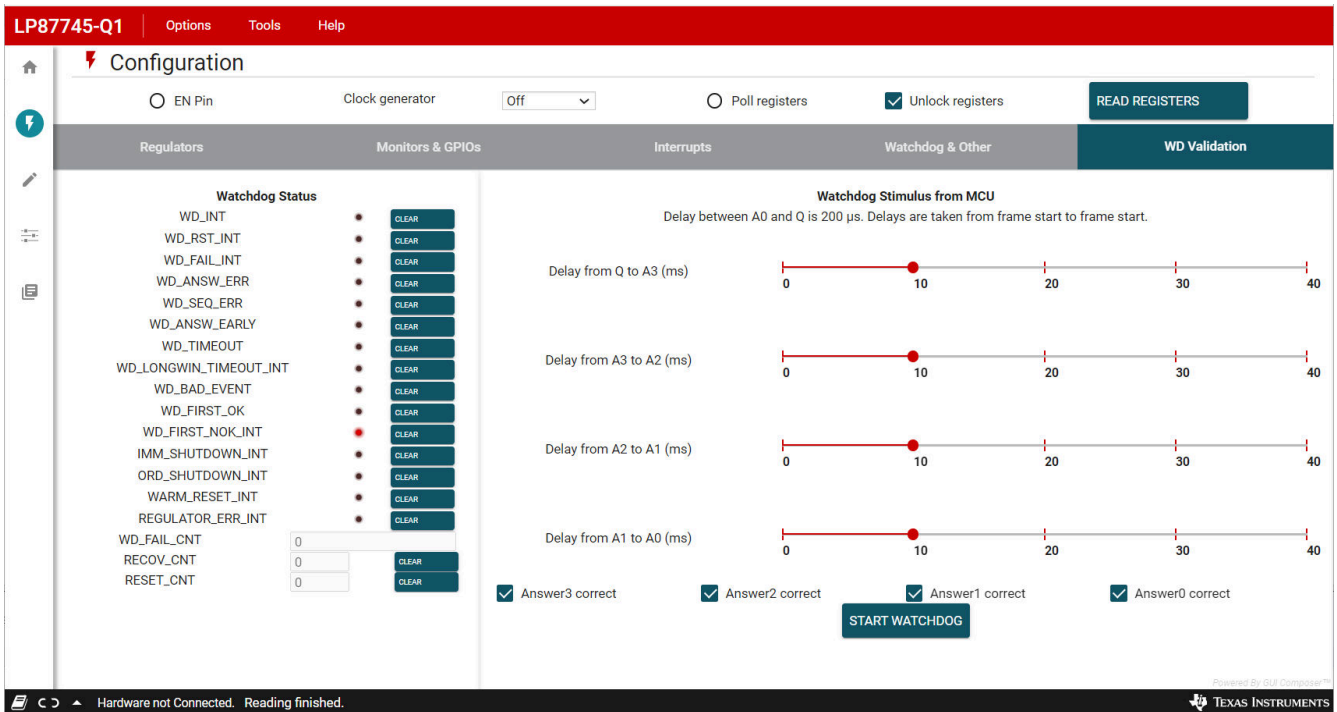

Figure 5-2. GUI Watchdog Validation Configuration

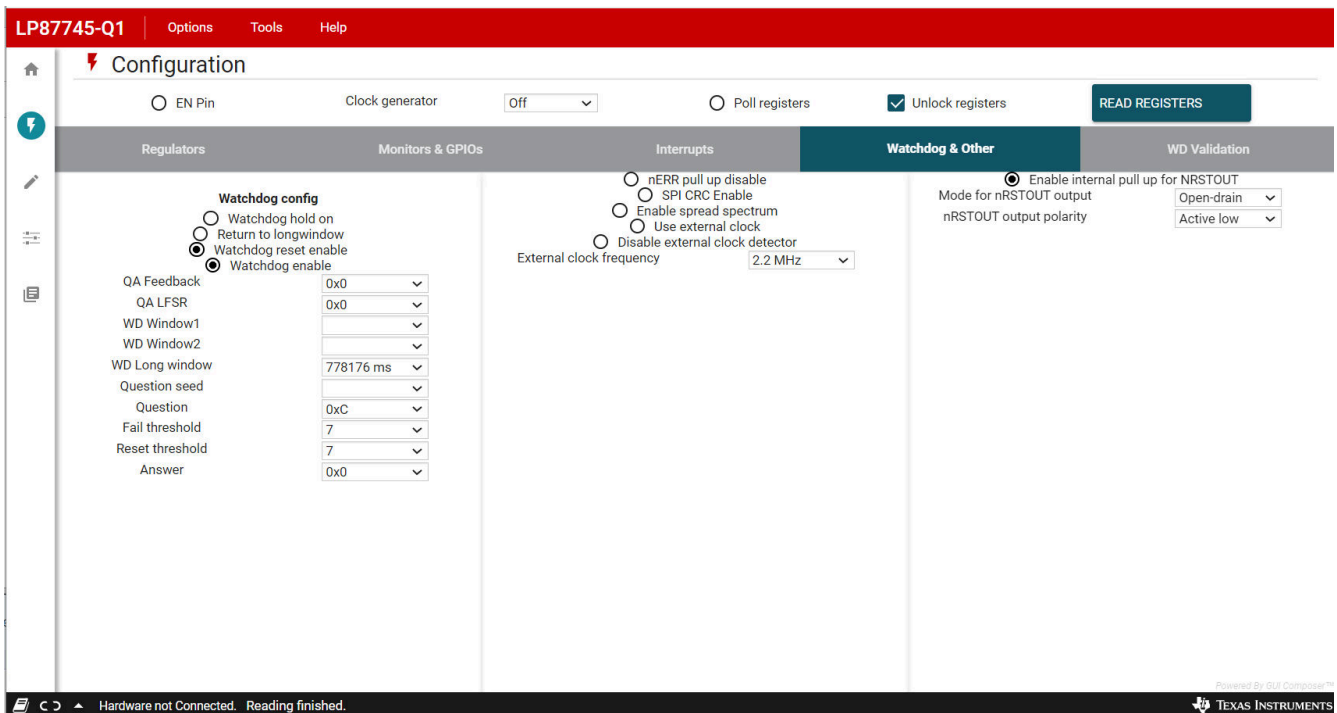

Figure 5-3. GUI Watchdog Configuration

6 Schematics, Layout and BOM

This section contains the schematics, layout and the bill of materials for the LP87745Q1EVM.

6.1 Schematic Diagram

This section includes images of the EVM schematics and different layers of the layout.

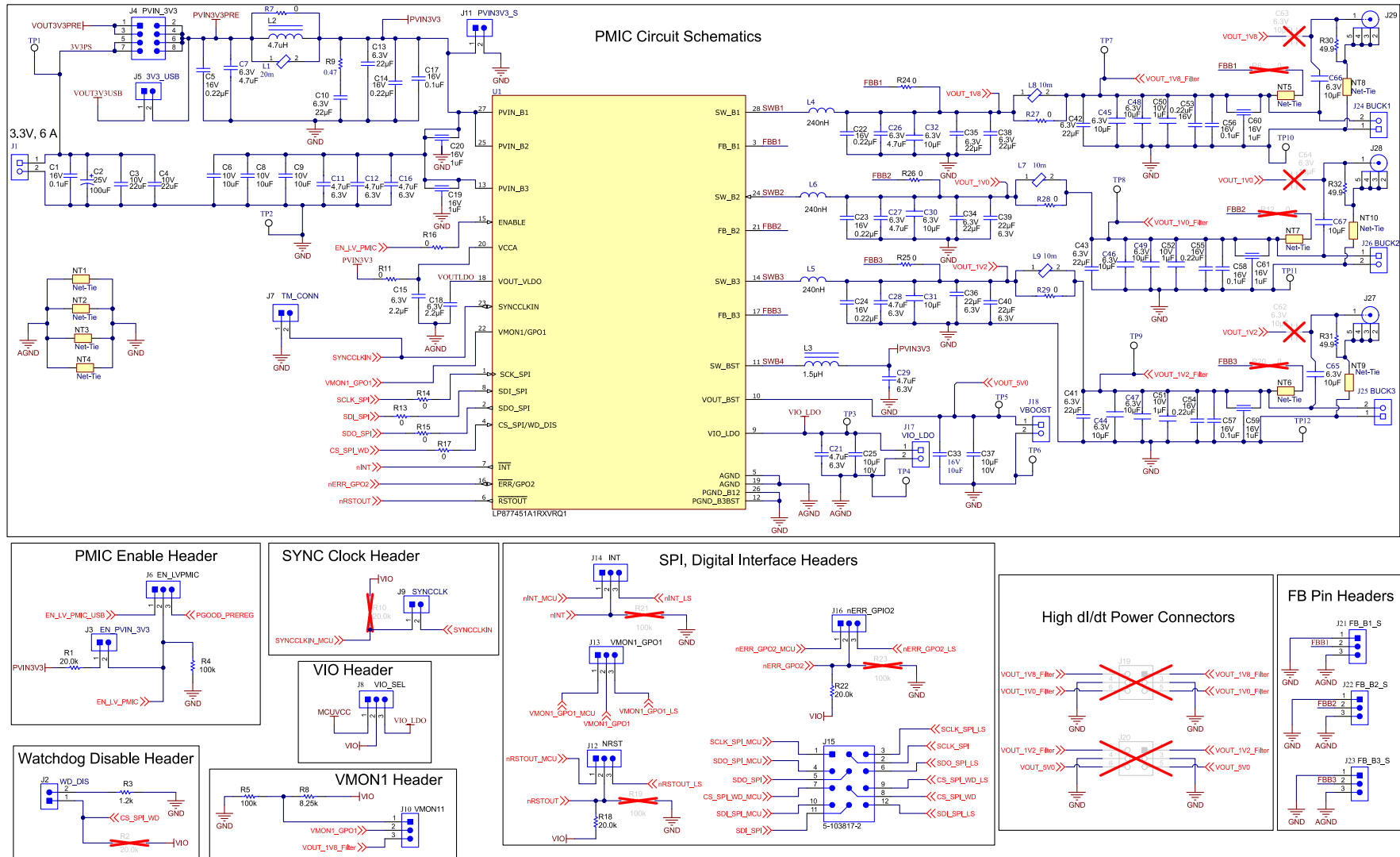

Figure 6-1. PMIC Schematic

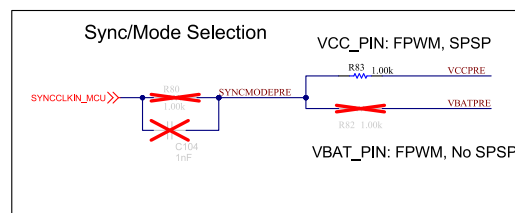
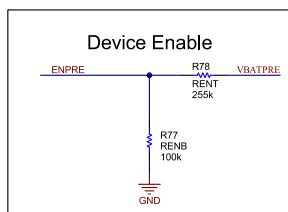
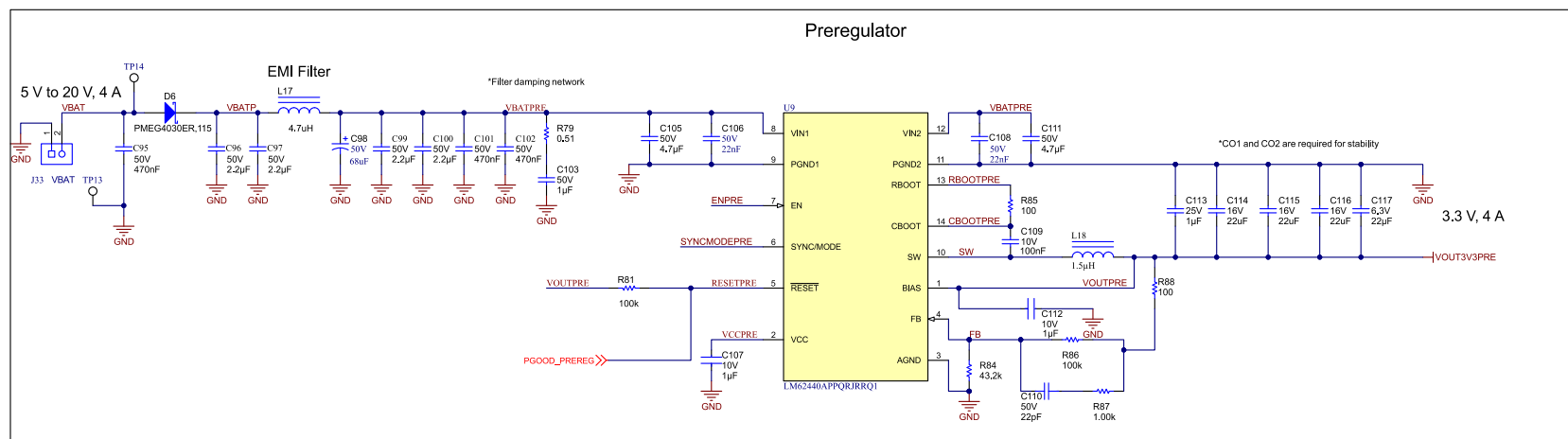

Figure 6-2. Preregulator Schematic

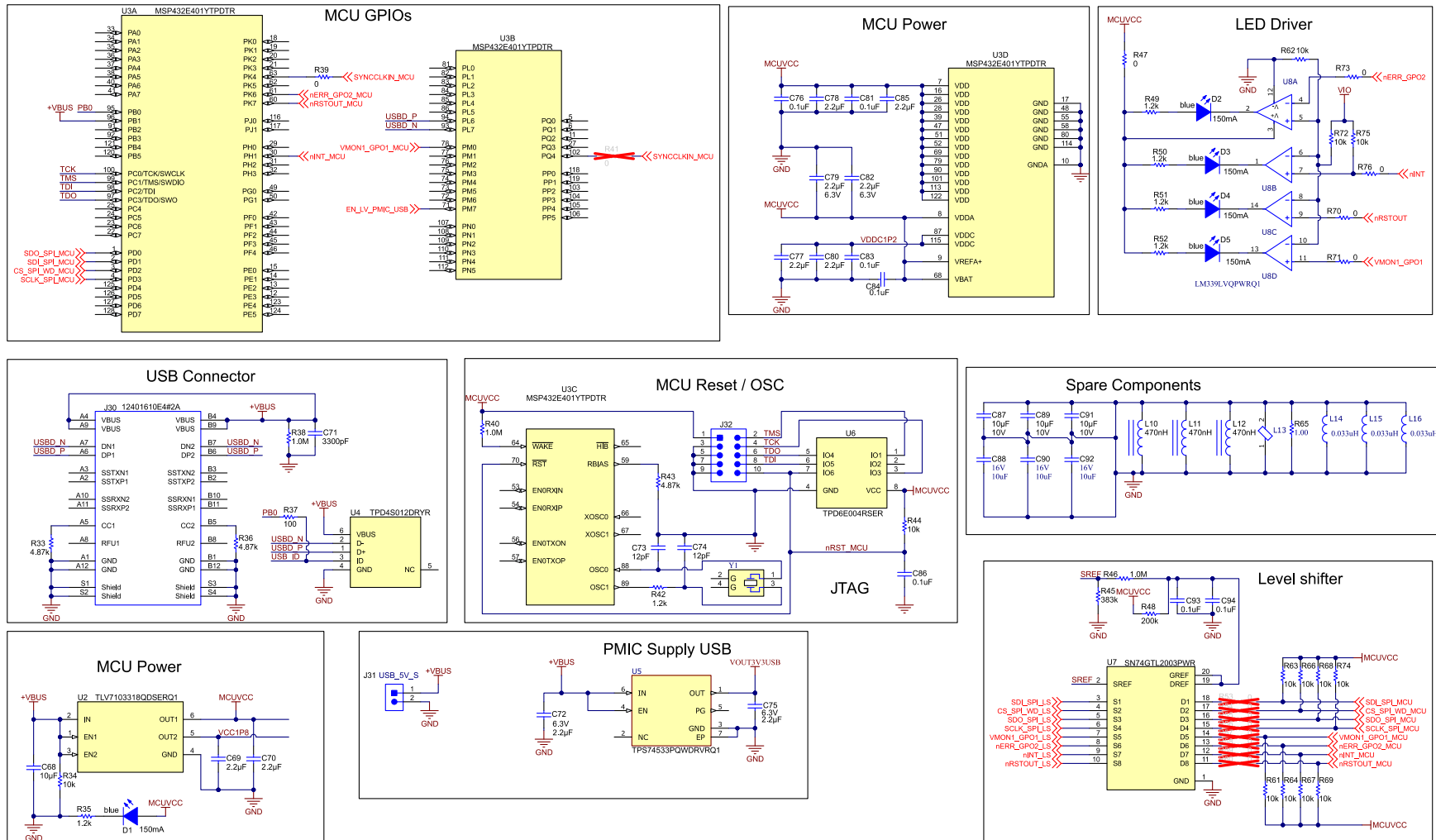

Figure 6-3. MCU Schematic

6.2 PCB Layer Diagram

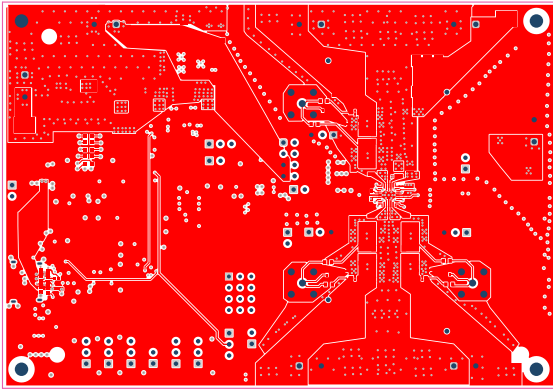

Figure 6-4. Layout of Top Layer, Layer 1

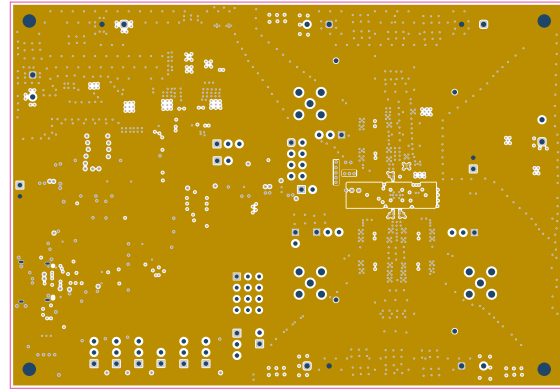

Figure 6-5. Layout of Ground layer 1, Layer 2

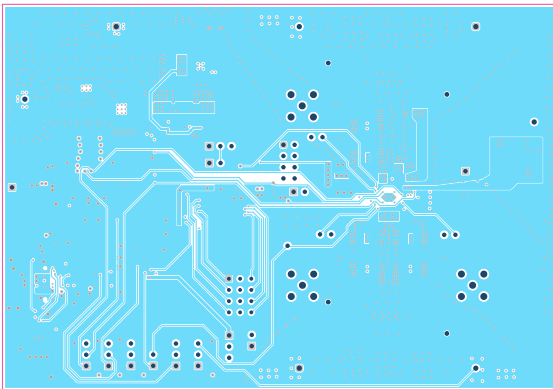

Figure 6-6. Layout of Signal Layer 1, Layer 3

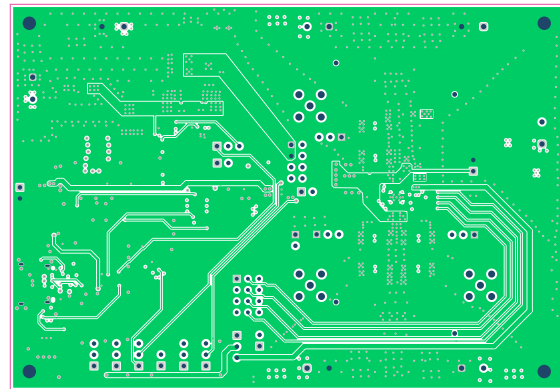

Figure 6-7. Layout of Signal Layer 2, Layer 4

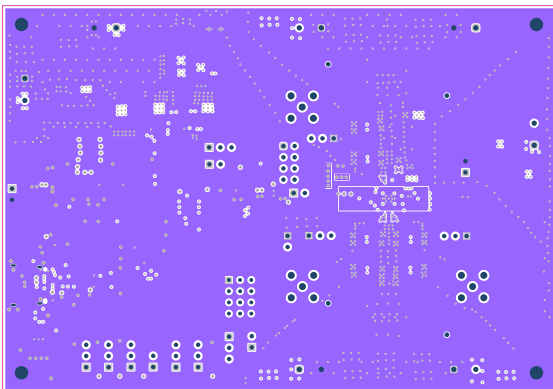

Figure 6-8. Layout of Ground Layer 2, Layer 5

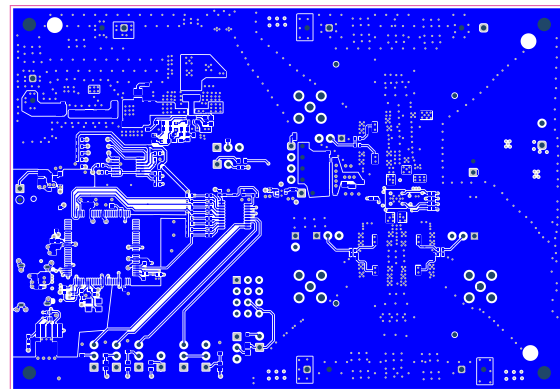

Figure 6-9. Layout of Bottom Layer, Layer 6

6.3 Components List

Table 6-1 lists all the components on the EVM.

Table 6-1. Components list

Designator	Quantity	Description	PartNumber	Manufacturer
!PCB1	1	Printed Circuit Board	BMC083	Any
C1, C17, C56, C57, C58, C76, C81, C83, C84, C86, C93, C94	12	CAP, CERM, 0.1 uF, 16 V, +/- 10%, X7R, 0402	GCM155R71C104KA55D	MuRata

Table 6-1. Components list (continued)

Designator	Quantity	Description	PartNumber	Manufacturer
C2	1	CAP, Polymer Hybrid, 100 uF, 25 V, +/- 20%, 30 ohm, 6.3x7.7 SMD	EEHZC1E101XP	Panasonic
C3, C4	2	CAP, CERM, 22 uF, 10 V, +/- 10%, X7R, AEC-Q200 Grade 1, 1206	GCM31CR71A226KE02L	MuRata
C5, C14, C22, C23, C24	5	CAP, CERM, 0.22 uF, 16 V, +/- 10%, X7R, AEC-Q200 Grade 1, 0402	GCM155R71C224KE02D	MuRata
C6, C8, C9, C25, C37, C68, C87, C89, C91	9	CAP, CERM, 10 uF, 10 V, +/- 10%, X7R, 0805	GCM21BR71A106KE22L	MuRata
C7, C11, C12, C16, C21, C26, C27, C28, C29	9	Cap Ceramic Multilayer 4.7uF 6.3V DC 10% SMD Paper T/R	GCJ188C70J475KE02J	Murata
C10, C13, C34, C35, C36, C38, C39, C40, C41, C42, C43, C117	12	CAP, CERM, 22 uF, 6.3 V, +/- 20%, X7T, AEC-Q200 Grade 1, 0805	CGA4J1X7T0J226M	TDK
C15, C18	2	CAP, CERM, 2.2 uF, 6.3 V, +/- 10%, X7R, 0603	GCM188R70J225KE22J	MuRata
C19, C20, C59, C60, C61	5	3 Terminals Low ESL Chip Multilayer Ceramic Capacitors for Automotive	NFM18HC105C1C3D	Murata
C30, C31, C32, C44, C45, C46, C47, C48, C49, C65, C66, C67	12	Chip Multilayer Ceramic Capacitors for Automotive	GCM188D70J106ME36D	Murata
C33, C88, C90, C92	4	CAP, CERM, 10 uF, 16 V, +/- 10%, X7S, AEC-Q200 Grade 1, 0805	CGA4J1X7S1C106K125AC	TDK
C50, C51, C52, C107, C112	5	CAP CER 0603 1UF 10V X7R 10%	C0603C105K8RACAUTO	KEMET
C53, C54, C55	3	CAP, CERM, 0.22 uF, 16 V, +/- 10%, X7R, 0402	GRM155R71C224KA12D	MuRata
C69, C70, C72, C75, C77, C78, C79, C80, C82, C85	10	CAP, CERM, 2.2 uF, 6.3 V, +/- 10%, X7R, AEC-Q200 Grade 1, 0603	GCM188R70J225KE22D	MuRata
C71	1	CAP, CERM, 3300 pF, 50 V, +/- 10%, X7R, 0603	C0603C332K5RACTU	Kemet
C73, C74	2	CAP, CERM, 12 pF, 50 V, +/- 5%, C0G/NP0, AEC-Q200 Grade 1, 0402	CGA2B2C0G1H120J050BA	TDK
C95, C101, C102	3	CAP, CERM, 0.47 uF, 50 V, +/- 10%, X7R, AEC-Q200 Grade 1, 0603	CGA3E3X7R1H474K080AE	TDK
C96, C97, C99, C100	4	CAP, CERM, 2.2 uF, 50 V, +/- 10%, X7R, AEC-Q200 Grade 1, 0805	CGA4J3X7R1H225K125AB	TDK
C98	1	CAP, Polymer Hybrid, 68 uF, 50 V, +/- 20%, 30 ohm, 8x10 SMD	EEHZA1H680P	Panasonic
C103	1	CAP, CERM, 1 uF, 50 V, +/- 10%, X7R, 0603	UMK107AB7105KA-T	Taiyo Yuden
C105, C111	2	CAP, CERM, 4.7 uF, 50 V, +/- 20%, X7R, AEC-Q200 Grade 1, 1210	UMK325B7475MMHT	Taiyo Yuden
C106, C108	2	CAP, CERM, 0.022 uF, 50 V, +/- 10%, X7R, 0402	GRM155R71H223KA12D	MuRata
C109	1	CAP, CERM, 0.1 uF, 10 V, +/- 10%, X7R, 0603	C0603X104K8RACTU	Kemet
C110	1	C0603 22 pF X7R 30ppm/C 10.00% 50 V	C0603C220K5RACAUTO	KEMET
C113	1	CAP, CERM, 1 uF, 25 V, +/- 10%, X7R, 0805	C0805C105K3RACTU	Kemet

Table 6-1. Components list (continued)

Designator	Quantity	Description	PartNumber	Manufacturer
C114, C115, C116	3	CAP, CERM, 22 uF, 16 V, +/- 20%, X7R, AEC-Q200 Grade 1, 1210	CGA6P1X7R1C226M250AC	TDK
D1, D2, D3, D4, D5	5	LED, Blue, SMD	LB Q39G-L2N2-35-1	OSRAM
D6	1	Diode, Schottky, 40 V, 3 A, AEC-Q101, SOD-123W	PMEG4030ER,115	Nexperia
H1, H4, H5, H7	4		FC2058-440-A	Fascomp
H2, H3, H6, H8	4	MACHINE SCREW PAN PHILLIPS 4-40	9900	Keystone
J1, J17, J18, J24, J25, J26, J33	7	Terminal Block, 5mm, 2x1, R/A, TH	1792863	Phoenix Contact
J2, J3, J5, J7, J9, J11, J31	7	Header, 100mil, 2x1, Gold, TH	HTSW-102-07-G-S	Samtec
J4	1	Header, 2.54mm, 4x2, Gold, TH	TSW-104-08-L-D	Samtec
J6, J8, J10, J12, J13, J14, J16, J21, J22, J23	10	Header, 100mil, 3x1, Gold, TH	HTSW-103-07-G-S	Samtec
J15	1	Header, 2.54mm, 4x3, Gold, TH	5-103817-2	TE Connectivity
J27, J28, J29	3	SMA Jack, Straight, 50 Ohm, Gold, TH	SMA-J-P-H-ST-TH1	Samtec
J30	1	Receptacle, 0.5mm, USB TYPE C, R/A, SMT	12401610E4#2A	Amphenol Canada
J32	1	Header (Shrouded), 1.27mm, 5x2, Gold, SMT	FTSH-105-01-F-DV-K	Samtec
L1	1	100 Ohms @ 100MHz 1 Power Line Ferrite Bead 0805 (2012 Metric) 4A 20mOhm	MPZ2012S101ATD25	TDK
L2, L17	2	Inductor, Shielded, Composite, 4.7 uH, 4.5 A, 0.0401 ohm, SMD	XAL4030-472MEB	Coilcraft
L3	1	Inductor, Shielded, Metal Composite, 1.5 uH, 2.3 A, 0.11 ohm, AEC-Q200 Grade 0, SMD	TFM201610ALMA1R5MTAA	TDK
L4, L5, L6	3	240nH Shielded Thin Film Inductor 5A 23mOhm Max 0806 (2016 Metric)	TFM201610ALMAR24MTAA	TDK
L7, L8, L9, L13	4	30 Ohms @ 100MHz 1 Power Line Ferrite Bead 0805 (2012 Metric) 6A 10mOhm	MPZ2012S300ATD25	TDK
L10, L11, L12	3	Inductor, Shielded, Metal Composite, 470 nH, 3.9 A, 0.039 ohm, AEC-Q200 Grade 0, SMD	TFM201610ALMAR47MTAA	TDK
L14, L15, L16	3	Fixed Inductor 0.033uH 30% 4.7A 9mOhm 0603	TFM160810ALTA33NNTAA	TDK
L18	1	Inductor, Shielded, Metal Composite, 1.5 uH, 5.8 A, 0.019 ohm, SMD	74438356015	Würth Elektronik
LBL1	1		THT-14-423-10	Brady
R1, R18, R22	3	RES, 20.0 k, 1%, 0.1 W, AEC-Q200 Grade 0, 0603	CRCW060320K0FKEA	Vishay-Dale
R3, R35, R42, R49, R50, R51, R52	7	RES, 1.2 k, 5%, 0.063 W, AEC-Q200 Grade 0, 0402	CRCW04021K20JNED	Vishay-Dale
R4, R5, R77, R81, R86	5	RES, 100 k, 1%, 0.1 W, 0603	RC0603FR-07100KL	Yageo
R7, R27, R28, R29	4	RES 0 OHM JUMPER 1/4W 0603	HCJ0603ZT0R00	Stackpole Electronics
R8	1	RES, 8.25 k, 1%, 0.1 W, AEC-Q200 Grade 0, 0603	CRCW06038K25FKEA	Vishay-Dale

Table 6-1. Components list (continued)

Designator	Quantity	Description	PartNumber	Manufacturer
R9	1	RES, 0.47, 1%, 0.1 W, AEC-Q200 Grade 0, 0603	ERJ-3RQFR47V	Panasonic
R11	1	RES, 0, 0%, 0.2 W, AEC-Q200 Grade 0, 0402	CRCW04020000Z0EDHP	Vishay-Dale
R13, R14, R15, R16, R17, R47, R70, R71, R73, R76	10	RES, 0, 5%, 0.063 W, AEC-Q200 Grade 0, 0402	CRCW04020000Z0ED	Vishay-Dale
R24, R25, R26, R39	4	RES, 0, 5%, 0.1 W, AEC-Q200 Grade 0, 0402	ERJ-2GE0R00X	Panasonic
R30, R31, R32	3	RES, 49.9, 1%, 0.063 W, AEC-Q200 Grade 0, 0402	RMCF0402FT49R9	Stackpole Electronics Inc
R33, R36, R43	3	RES, 4.87 k, 1%, 0.063 W, AEC-Q200 Grade 0, 0402	CRCW04024K87FKED	Vishay-Dale
R34, R44, R61, R62, R63, R64, R66, R67, R68, R69, R72, R74, R75	13	RES, 10 k, 5%, 0.063 W, AEC-Q200 Grade 0, 0402	CRCW040210K0JNED	Vishay-Dale
R37	1	RES, 100, 5%, 0.063 W, AEC-Q200 Grade 0, 0402	CRCW0402100RJNED	Vishay-Dale
R38, R40, R46	3	RES, 1.0 M, 5%, 0.063 W, AEC-Q200 Grade 0, 0402	CRCW04021M00JNED	Vishay-Dale
R45	1	RES, 383 k, 1%, 0.063 W, AEC-Q200 Grade 0, 0402	CRCW0402383KFKED	Vishay-Dale
R48	1	RES, 200 k, 5%, 0.063 W, AEC-Q200 Grade 0, 0402	CRCW0402200KJNED	Vishay-Dale
R65	1	RES, 1.00, 1%, 0.1 W, 0603	RC0603FR-071RL	Yageo
R78	1	RES, 255 k, 1%, 0.1 W, 0603	RC0603FR-07255KL	Yageo
R79	1	RES, 0.51, 1%, 0.25 W, 0805	CRM0805-FX-R510ELF	Bourns
R83	1	RES, 1.00 k, 1%, 0.1 W, 0603	RC0603FR-071KL	Yageo
R84	1	RES, 43.2 k, 1%, 0.1 W, AEC-Q200 Grade 0, 0603	CRCW060343K2FKEA	Vishay-Dale
R85	1	RES, 100, 5%, 0.1 W, AEC-Q200 Grade 0, 0603	CRCW0603100RJNEA	Vishay-Dale
R87	1	RES, 1.00 k, 1%, 0.1 W, 0603	ERJ-3EKF1001V	Panasonic
R88	1	RES, 100, 1%, 0.1 W, 0603	RC0603FR-07100RL	Yageo
SH-J1, SH-J2, SH-J3, SH-J4, SH-J5, SH-J6, SH-J7, SH-J8, SH-J9, SH-J10, SH-J11, SH-J12, SH-J13, SH-J14	14	Shunt, 100mil, Gold plated, Black	881545-2	TE Connectivity
TP1, TP2, TP3, TP4, TP5, TP6, TP7, TP8, TP9, TP10, TP11, TP12, TP13, TP14	14	Test Point, Compact, SMT	5016	Keystone
U1	1	Three Buck Converters and 5-V Boost for AWR and IWR Radar Sensors	LP877451A1RXVRQ1	Texas Instruments
U2	1	Automotive Catalog, Dual, 200mA, Low-IQ Low-Dropout Regulator for Portable Devices, DSE0006A (WSON-6)	TLV7103318QDSERQ1	Texas Instruments

Table 6-1. Components list (continued)

Designator	Quantity	Description	PartNumber	Manufacturer
U3	1	MSP432E401YTPDT, PDT0128A (TQFP-128)	MSP432E401YTPDTR	Texas Instruments
U4	1	4-Channel USB ESD Solution with Power Clamp, DRY0006A (USON-6)	TPD4S012DRYR	Texas Instruments
U5	1	Linear Voltage Regulator IC 1 Output 500mA 6-WSON (2x2)	TPS74533PQWDRVRQ1	Texas Instruments
U6	1	Low-Capacitance 6-Channel +/-15 kV ESD Protection Array for High-Speed Data Interfaces, RSE0008A (UQFN-8)	TPD6E004RSER	Texas Instruments
U7	1	8-BIT BIDIRECTIONAL LOW-VOLTAGE TRANSLATOR, PW0020A (TSSOP-20)	SN74GTL2003PWR	Texas Instruments
U8	1	Automotive 5.5-V low-voltage standard quad-channel comparator with 1-microsecond delay 14-TSSOP -40 to 125	LM339LVQPWRQ1	Texas Instruments
U9	1	Automotive 4 A Low Noise Synchronous Buck Regulators, RJR0014A (VQFN-HR-14)	LM62440APPQRJRRQ1	Texas Instruments
Y1	1	Crystal, 25 MHz, 20 ppm, AEC-Q200 Grade 1, SMD	ECS-250-12-33Q-JES-TR	ECS Inc.
C62, C63, C64	0	Chip Multilayer Ceramic Capacitors for Automotive	GCM188D70J106ME36D	Murata
C104	0	CAP, CERM, 1000 pF, 50 V, +/- 10%, X7R, 0603	C0603C102K5RACTU	Kemet
J19, J20	0	Receptacle, 2.5mm, 3x2, Gold, SMT	6651712-1	TE Connectivity
R2, R10	0	RES, 20.0 k, 1%, 0.1 W, AEC-Q200 Grade 0, 0603	CRCW060320K0FKEA	Vishay-Dale
R6, R12, R20, R53, R54, R55, R56, R57, R58, R59, R60	0	RES, 0, 5%, 0.063 W, AEC-Q200 Grade 0, 0402	CRCW04020000Z0ED	Vishay-Dale
R19, R21, R23	0	RES, 100 k, 1%, 0.1 W, 0603	RC0603FR-07100KL	Yageo
R41	0	RES, 0, 5%, 0.1 W, AEC-Q200 Grade 0, 0402	ERJ-2GE0R00X	Panasonic
R80, R82	0	RES, 1.00 k, 1%, 0.1 W, 0603	RC0603FR-071KL	Yageo

7 Revision History

NOTE: Page numbers for previous revisions may differ from page numbers in the current version.

Changes from Revision * (September 2021) to Revision A (October 2022)

Page

• Updated Figure 1-1	2
• Updated VCCA monitoring voltage threshold levels.....	3
• Designators updated to the latest revision.....	4
• Updated the Figure 4-1	8
• Updated the watchdog section.....	12
• Updated the schematic diagrams.....	15
• Updated the bill of materials.....	18

STANDARD TERMS FOR EVALUATION MODULES

1. *Delivery:* TI delivers TI evaluation boards, kits, or modules, including any accompanying demonstration software, components, and/or documentation which may be provided together or separately (collectively, an "EVM" or "EVMs") to the User ("User") in accordance with the terms set forth herein. User's acceptance of the EVM is expressly subject to the following terms.
 - 1.1 EVMs are intended solely for product or software developers for use in a research and development setting to facilitate feasibility evaluation, experimentation, or scientific analysis of TI semiconductors products. EVMs have no direct function and are not finished products. EVMs shall not be directly or indirectly assembled as a part or subassembly in any finished product. For clarification, any software or software tools provided with the EVM ("Software") shall not be subject to the terms and conditions set forth herein but rather shall be subject to the applicable terms that accompany such Software
 - 1.2 EVMs are not intended for consumer or household use. EVMs may not be sold, sublicensed, leased, rented, loaned, assigned, or otherwise distributed for commercial purposes by Users, in whole or in part, or used in any finished product or production system.
2. *Limited Warranty and Related Remedies/Disclaimers:*
 - 2.1 These terms do not apply to Software. The warranty, if any, for Software is covered in the applicable Software License Agreement.
 - 2.2 TI warrants that the TI EVM will conform to TI's published specifications for ninety (90) days after the date TI delivers such EVM to User. Notwithstanding the foregoing, TI shall not be liable for a nonconforming EVM if (a) the nonconformity was caused by neglect, misuse or mistreatment by an entity other than TI, including improper installation or testing, or for any EVMs that have been altered or modified in any way by an entity other than TI, (b) the nonconformity resulted from User's design, specifications or instructions for such EVMs or improper system design, or (c) User has not paid on time. Testing and other quality control techniques are used to the extent TI deems necessary. TI does not test all parameters of each EVM. User's claims against TI under this Section 2 are void if User fails to notify TI of any apparent defects in the EVMs within ten (10) business days after delivery, or of any hidden defects with ten (10) business days after the defect has been detected.
 - 2.3 TI's sole liability shall be at its option to repair or replace EVMs that fail to conform to the warranty set forth above, or credit User's account for such EVM. TI's liability under this warranty shall be limited to EVMs that are returned during the warranty period to the address designated by TI and that are determined by TI not to conform to such warranty. If TI elects to repair or replace such EVM, TI shall have a reasonable time to repair such EVM or provide replacements. Repaired EVMs shall be warranted for the remainder of the original warranty period. Replaced EVMs shall be warranted for a new full ninety (90) day warranty period.

WARNING

Evaluation Kits are intended solely for use by technically qualified, professional electronics experts who are familiar with the dangers and application risks associated with handling electrical mechanical components, systems, and subsystems.

User shall operate the Evaluation Kit within TI's recommended guidelines and any applicable legal or environmental requirements as well as reasonable and customary safeguards. Failure to set up and/or operate the Evaluation Kit within TI's recommended guidelines may result in personal injury or death or property damage. Proper set up entails following TI's instructions for electrical ratings of interface circuits such as input, output and electrical loads.

NOTE:

EXPOSURE TO ELECTROSTATIC DISCHARGE (ESD) MAY CAUSE DEGRADATION OR FAILURE OF THE EVALUATION KIT; TI RECOMMENDS STORAGE OF THE EVALUATION KIT IN A PROTECTIVE ESD BAG.

3 Regulatory Notices:

3.1 United States

3.1.1 Notice applicable to EVMs not FCC-Approved:

FCC NOTICE: This kit is designed to allow product developers to evaluate electronic components, circuitry, or software associated with the kit to determine whether to incorporate such items in a finished product and software developers to write software applications for use with the end product. This kit is not a finished product and when assembled may not be resold or otherwise marketed unless all required FCC equipment authorizations are first obtained. Operation is subject to the condition that this product not cause harmful interference to licensed radio stations and that this product accept harmful interference. Unless the assembled kit is designed to operate under part 15, part 18 or part 95 of this chapter, the operator of the kit must operate under the authority of an FCC license holder or must secure an experimental authorization under part 5 of this chapter.

3.1.2 For EVMs annotated as FCC – FEDERAL COMMUNICATIONS COMMISSION Part 15 Compliant:

CAUTION

This device complies with part 15 of the FCC Rules. Operation is subject to the following two conditions: (1) This device may not cause harmful interference, and (2) this device must accept any interference received, including interference that may cause undesired operation.

Changes or modifications not expressly approved by the party responsible for compliance could void the user's authority to operate the equipment.

FCC Interference Statement for Class A EVM devices

NOTE: This equipment has been tested and found to comply with the limits for a Class A digital device, pursuant to part 15 of the FCC Rules. These limits are designed to provide reasonable protection against harmful interference when the equipment is operated in a commercial environment. This equipment generates, uses, and can radiate radio frequency energy and, if not installed and used in accordance with the instruction manual, may cause harmful interference to radio communications. Operation of this equipment in a residential area is likely to cause harmful interference in which case the user will be required to correct the interference at his own expense.

FCC Interference Statement for Class B EVM devices

NOTE: This equipment has been tested and found to comply with the limits for a Class B digital device, pursuant to part 15 of the FCC Rules. These limits are designed to provide reasonable protection against harmful interference in a residential installation. This equipment generates, uses and can radiate radio frequency energy and, if not installed and used in accordance with the instructions, may cause harmful interference to radio communications. However, there is no guarantee that interference will not occur in a particular installation. If this equipment does cause harmful interference to radio or television reception, which can be determined by turning the equipment off and on, the user is encouraged to try to correct the interference by one or more of the following measures:

- Reorient or relocate the receiving antenna.
- Increase the separation between the equipment and receiver.
- Connect the equipment into an outlet on a circuit different from that to which the receiver is connected.
- Consult the dealer or an experienced radio/TV technician for help.

3.2 Canada

3.2.1 For EVMs issued with an Industry Canada Certificate of Conformance to RSS-210 or RSS-247

Concerning EVMs Including Radio Transmitters:

This device complies with Industry Canada license-exempt RSSs. Operation is subject to the following two conditions:

(1) this device may not cause interference, and (2) this device must accept any interference, including interference that may cause undesired operation of the device.

Concernant les EVMs avec appareils radio:

Le présent appareil est conforme aux CNR d'Industrie Canada applicables aux appareils radio exempts de licence. L'exploitation est autorisée aux deux conditions suivantes: (1) l'appareil ne doit pas produire de brouillage, et (2) l'utilisateur de l'appareil doit accepter tout brouillage radioélectrique subi, même si le brouillage est susceptible d'en compromettre le fonctionnement.

Concerning EVMs Including Detachable Antennas:

Under Industry Canada regulations, this radio transmitter may only operate using an antenna of a type and maximum (or lesser) gain approved for the transmitter by Industry Canada. To reduce potential radio interference to other users, the antenna type and its gain should be so chosen that the equivalent isotropically radiated power (e.i.r.p.) is not more than that necessary for successful communication. This radio transmitter has been approved by Industry Canada to operate with the antenna types listed in the user guide with the maximum permissible gain and required antenna impedance for each antenna type indicated. Antenna types not included in this list, having a gain greater than the maximum gain indicated for that type, are strictly prohibited for use with this device.

Concernant les EVMs avec antennes détachables

Conformément à la réglementation d'Industrie Canada, le présent émetteur radio peut fonctionner avec une antenne d'un type et d'un gain maximal (ou inférieur) approuvé pour l'émetteur par Industrie Canada. Dans le but de réduire les risques de brouillage radioélectrique à l'intention des autres utilisateurs, il faut choisir le type d'antenne et son gain de sorte que la puissance isotrope rayonnée équivalente (p.i.r.e.) ne dépasse pas l'intensité nécessaire à l'établissement d'une communication satisfaisante. Le présent émetteur radio a été approuvé par Industrie Canada pour fonctionner avec les types d'antenne énumérés dans le manuel d'usage et ayant un gain admissible maximal et l'impédance requise pour chaque type d'antenne. Les types d'antenne non inclus dans cette liste, ou dont le gain est supérieur au gain maximal indiqué, sont strictement interdits pour l'exploitation de l'émetteur.

3.3 Japan

3.3.1 *Notice for EVMs delivered in Japan:* Please see http://www.tij.co.jp/lstds/ti_ja/general/eStore/notice_01.page 日本国内に輸入される評価用キット、ボードについては、次のところをご覧ください。

<https://www.ti.com/ja-jp/legal/notice-for-evaluation-kits-delivered-in-japan.html>

3.3.2 *Notice for Users of EVMs Considered "Radio Frequency Products" in Japan:* EVMs entering Japan may not be certified by TI as conforming to Technical Regulations of Radio Law of Japan.

If User uses EVMs in Japan, not certified to Technical Regulations of Radio Law of Japan, User is required to follow the instructions set forth by Radio Law of Japan, which includes, but is not limited to, the instructions below with respect to EVMs (which for the avoidance of doubt are stated strictly for convenience and should be verified by User):

1. Use EVMs in a shielded room or any other test facility as defined in the notification #173 issued by Ministry of Internal Affairs and Communications on March 28, 2006, based on Sub-section 1.1 of Article 6 of the Ministry's Rule for Enforcement of Radio Law of Japan,
2. Use EVMs only after User obtains the license of Test Radio Station as provided in Radio Law of Japan with respect to EVMs, or
3. Use of EVMs only after User obtains the Technical Regulations Conformity Certification as provided in Radio Law of Japan with respect to EVMs. Also, do not transfer EVMs, unless User gives the same notice above to the transferee. Please note that if User does not follow the instructions above, User will be subject to penalties of Radio Law of Japan.

【無線電波を送信する製品の開発キットをお使いになる際の注意事項】 開発キットの中には技術基準適合証明を受けていないものがあります。技術適合証明を受けていないものご使用に際しては、電波法遵守のため、以下のいずれかの措置を取っていただく必要がありますのでご注意ください。

1. 電波法施行規則第6条第1項第1号に基づく平成18年3月28日総務省告示第173号で定められた電波暗室等の試験設備でご使用いただく。
2. 実験局の免許を取得後ご使用いただく。
3. 技術基準適合証明を取得後ご使用いただく。

なお、本製品は、上記の「ご使用にあたっての注意」を譲渡先、移転先に通知しない限り、譲渡、移転できないものとします。

上記を遵守頂けない場合は、電波法の罰則が適用される可能性があることをご留意ください。日本テキサス・イ

ンスツルメンツ株式会社

東京都新宿区西新宿 6 丁目 2 4 番 1 号

西新宿三井ビル

3.3.3 *Notice for EVMs for Power Line Communication:* Please see http://www.tij.co.jp/lstds/ti_ja/general/eStore/notice_02.page

電力線搬送波通信についての開発キットをお使いになる際の注意事項については、次のところをご覧ください。 <https://www.ti.com/ja-jp/legal/notice-for-evaluation-kits-for-power-line-communication.html>

3.4 European Union

3.4.1 *For EVMs subject to EU Directive 2014/30/EU (Electromagnetic Compatibility Directive):*

This is a class A product intended for use in environments other than domestic environments that are connected to a low-voltage power-supply network that supplies buildings used for domestic purposes. In a domestic environment this product may cause radio interference in which case the user may be required to take adequate measures.

-
4. *EVM Use Restrictions and Warnings:*
 - 4.1 EVMS ARE NOT FOR USE IN FUNCTIONAL SAFETY AND/OR SAFETY CRITICAL EVALUATIONS, INCLUDING BUT NOT LIMITED TO EVALUATIONS OF LIFE SUPPORT APPLICATIONS.
 - 4.2 User must read and apply the user guide and other available documentation provided by TI regarding the EVM prior to handling or using the EVM, including without limitation any warning or restriction notices. The notices contain important safety information related to, for example, temperatures and voltages.
 - 4.3 *Safety-Related Warnings and Restrictions:*
 - 4.3.1 User shall operate the EVM within TI's recommended specifications and environmental considerations stated in the user guide, other available documentation provided by TI, and any other applicable requirements and employ reasonable and customary safeguards. Exceeding the specified performance ratings and specifications (including but not limited to input and output voltage, current, power, and environmental ranges) for the EVM may cause personal injury or death, or property damage. If there are questions concerning performance ratings and specifications, User should contact a TI field representative prior to connecting interface electronics including input power and intended loads. Any loads applied outside of the specified output range may also result in unintended and/or inaccurate operation and/or possible permanent damage to the EVM and/or interface electronics. Please consult the EVM user guide prior to connecting any load to the EVM output. If there is uncertainty as to the load specification, please contact a TI field representative. During normal operation, even with the inputs and outputs kept within the specified allowable ranges, some circuit components may have elevated case temperatures. These components include but are not limited to linear regulators, switching transistors, pass transistors, current sense resistors, and heat sinks, which can be identified using the information in the associated documentation. When working with the EVM, please be aware that the EVM may become very warm.
 - 4.3.2 EVMs are intended solely for use by technically qualified, professional electronics experts who are familiar with the dangers and application risks associated with handling electrical mechanical components, systems, and subsystems. User assumes all responsibility and liability for proper and safe handling and use of the EVM by User or its employees, affiliates, contractors or designees. User assumes all responsibility and liability to ensure that any interfaces (electronic and/or mechanical) between the EVM and any human body are designed with suitable isolation and means to safely limit accessible leakage currents to minimize the risk of electrical shock hazard. User assumes all responsibility and liability for any improper or unsafe handling or use of the EVM by User or its employees, affiliates, contractors or designees.
 - 4.4 User assumes all responsibility and liability to determine whether the EVM is subject to any applicable international, federal, state, or local laws and regulations related to User's handling and use of the EVM and, if applicable, User assumes all responsibility and liability for compliance in all respects with such laws and regulations. User assumes all responsibility and liability for proper disposal and recycling of the EVM consistent with all applicable international, federal, state, and local requirements.
 5. *Accuracy of Information:* To the extent TI provides information on the availability and function of EVMs, TI attempts to be as accurate as possible. However, TI does not warrant the accuracy of EVM descriptions, EVM availability or other information on its websites as accurate, complete, reliable, current, or error-free.
 6. *Disclaimers:*
 - 6.1 EXCEPT AS SET FORTH ABOVE, EVMS AND ANY MATERIALS PROVIDED WITH THE EVM (INCLUDING, BUT NOT LIMITED TO, REFERENCE DESIGNS AND THE DESIGN OF THE EVM ITSELF) ARE PROVIDED "AS IS" AND "WITH ALL FAULTS." TI DISCLAIMS ALL OTHER WARRANTIES, EXPRESS OR IMPLIED, REGARDING SUCH ITEMS, INCLUDING BUT NOT LIMITED TO ANY EPIDEMIC FAILURE WARRANTY OR IMPLIED WARRANTIES OF MERCHANTABILITY OR FITNESS FOR A PARTICULAR PURPOSE OR NON-INFRINGEMENT OF ANY THIRD PARTY PATENTS, COPYRIGHTS, TRADE SECRETS OR OTHER INTELLECTUAL PROPERTY RIGHTS.
 - 6.2 EXCEPT FOR THE LIMITED RIGHT TO USE THE EVM SET FORTH HEREIN, NOTHING IN THESE TERMS SHALL BE CONSTRUED AS GRANTING OR CONFERRING ANY RIGHTS BY LICENSE, PATENT, OR ANY OTHER INDUSTRIAL OR INTELLECTUAL PROPERTY RIGHT OF TI, ITS SUPPLIERS/LICENSORS OR ANY OTHER THIRD PARTY, TO USE THE EVM IN ANY FINISHED END-USER OR READY-TO-USE FINAL PRODUCT, OR FOR ANY INVENTION, DISCOVERY OR IMPROVEMENT, REGARDLESS OF WHEN MADE, CONCEIVED OR ACQUIRED.
 7. *USER'S INDEMNITY OBLIGATIONS AND REPRESENTATIONS.* USER WILL DEFEND, INDEMNIFY AND HOLD TI, ITS LICENSORS AND THEIR REPRESENTATIVES HARMLESS FROM AND AGAINST ANY AND ALL CLAIMS, DAMAGES, LOSSES, EXPENSES, COSTS AND LIABILITIES (COLLECTIVELY, "CLAIMS") ARISING OUT OF OR IN CONNECTION WITH ANY HANDLING OR USE OF THE EVM THAT IS NOT IN ACCORDANCE WITH THESE TERMS. THIS OBLIGATION SHALL APPLY WHETHER CLAIMS ARISE UNDER STATUTE, REGULATION, OR THE LAW OF TORT, CONTRACT OR ANY OTHER LEGAL THEORY, AND EVEN IF THE EVM FAILS TO PERFORM AS DESCRIBED OR EXPECTED.
-

8. *Limitations on Damages and Liability:*

8.1 *General Limitations.* IN NO EVENT SHALL TI BE LIABLE FOR ANY SPECIAL, COLLATERAL, INDIRECT, PUNITIVE, INCIDENTAL, CONSEQUENTIAL, OR EXEMPLARY DAMAGES IN CONNECTION WITH OR ARISING OUT OF THESE TERMS OR THE USE OF THE EVMS , REGARDLESS OF WHETHER TI HAS BEEN ADVISED OF THE POSSIBILITY OF SUCH DAMAGES. EXCLUDED DAMAGES INCLUDE, BUT ARE NOT LIMITED TO, COST OF REMOVAL OR REINSTALLATION, ANCILLARY COSTS TO THE PROCUREMENT OF SUBSTITUTE GOODS OR SERVICES, RETESTING, OUTSIDE COMPUTER TIME, LABOR COSTS, LOSS OF GOODWILL, LOSS OF PROFITS, LOSS OF SAVINGS, LOSS OF USE, LOSS OF DATA, OR BUSINESS INTERRUPTION. NO CLAIM, SUIT OR ACTION SHALL BE BROUGHT AGAINST TI MORE THAN TWELVE (12) MONTHS AFTER THE EVENT THAT GAVE RISE TO THE CAUSE OF ACTION HAS OCCURRED.

8.2 *Specific Limitations.* IN NO EVENT SHALL TI'S AGGREGATE LIABILITY FROM ANY USE OF AN EVM PROVIDED HEREUNDER, INCLUDING FROM ANY WARRANTY, INDEMNITY OR OTHER OBLIGATION ARISING OUT OF OR IN CONNECTION WITH THESE TERMS, , EXCEED THE TOTAL AMOUNT PAID TO TI BY USER FOR THE PARTICULAR EVM(S) AT ISSUE DURING THE PRIOR TWELVE (12) MONTHS WITH RESPECT TO WHICH LOSSES OR DAMAGES ARE CLAIMED. THE EXISTENCE OF MORE THAN ONE CLAIM SHALL NOT ENLARGE OR EXTEND THIS LIMIT.

9. *Return Policy.* Except as otherwise provided, TI does not offer any refunds, returns, or exchanges. Furthermore, no return of EVM(s) will be accepted if the package has been opened and no return of the EVM(s) will be accepted if they are damaged or otherwise not in a resalable condition. If User feels it has been incorrectly charged for the EVM(s) it ordered or that delivery violates the applicable order, User should contact TI. All refunds will be made in full within thirty (30) working days from the return of the components(s), excluding any postage or packaging costs.

10. *Governing Law:* These terms and conditions shall be governed by and interpreted in accordance with the laws of the State of Texas, without reference to conflict-of-laws principles. User agrees that non-exclusive jurisdiction for any dispute arising out of or relating to these terms and conditions lies within courts located in the State of Texas and consents to venue in Dallas County, Texas. Notwithstanding the foregoing, any judgment may be enforced in any United States or foreign court, and TI may seek injunctive relief in any United States or foreign court.

Mailing Address: Texas Instruments, Post Office Box 655303, Dallas, Texas 75265
Copyright © 2023, Texas Instruments Incorporated

IMPORTANT NOTICE AND DISCLAIMER

TI PROVIDES TECHNICAL AND RELIABILITY DATA (INCLUDING DATASHEETS), DESIGN RESOURCES (INCLUDING REFERENCE DESIGNS), APPLICATION OR OTHER DESIGN ADVICE, WEB TOOLS, SAFETY INFORMATION, AND OTHER RESOURCES "AS IS" AND WITH ALL FAULTS, AND DISCLAIMS ALL WARRANTIES, EXPRESS AND IMPLIED, INCLUDING WITHOUT LIMITATION ANY IMPLIED WARRANTIES OF MERCHANTABILITY, FITNESS FOR A PARTICULAR PURPOSE OR NON-INFRINGEMENT OF THIRD PARTY INTELLECTUAL PROPERTY RIGHTS.

These resources are intended for skilled developers designing with TI products. You are solely responsible for (1) selecting the appropriate TI products for your application, (2) designing, validating and testing your application, and (3) ensuring your application meets applicable standards, and any other safety, security, regulatory or other requirements.

These resources are subject to change without notice. TI grants you permission to use these resources only for development of an application that uses the TI products described in the resource. Other reproduction and display of these resources is prohibited. No license is granted to any other TI intellectual property right or to any third party intellectual property right. TI disclaims responsibility for, and you fully indemnify TI and its representatives against any claims, damages, costs, losses, and liabilities arising out of your use of these resources.

TI's products are provided subject to [TI's Terms of Sale](#), [TI's General Quality Guidelines](#), or other applicable terms available either on [ti.com](#) or provided in conjunction with such TI products. TI's provision of these resources does not expand or otherwise alter TI's applicable warranties or warranty disclaimers for TI products. Unless TI explicitly designates a product as custom or customer-specified, TI products are standard, catalog, general purpose devices.

TI objects to and rejects any additional or different terms you may propose.

Copyright © 2025, Texas Instruments Incorporated

Last updated 10/2025