

Test Report of PMP10565

(Flybuck with LM5160)

17 Dec. 2014



Table of Contents

1) Design Specifications	2
2) Circuit Schematic	3
3) Typical Performances	4
3.1) Board and Thermal	4
3.2) Efficiency and Cross Regulation	5
3.3) Dynamic Response	9
3.4) Start up and Shutdown.....	11
3.5) Output Ripple	12
3.6) Primary Current, SW and secondary voltage of transformer	14

1) Design Specifications

Vin	24Vdc
Vout1	5Vdc
Iout1	0.5A
Vout2	15Vdc
Iout2	0.2A
Vout3	5Vdc
Iout3	0.2A
Switching frequency	330k

2) Circuit Schematic

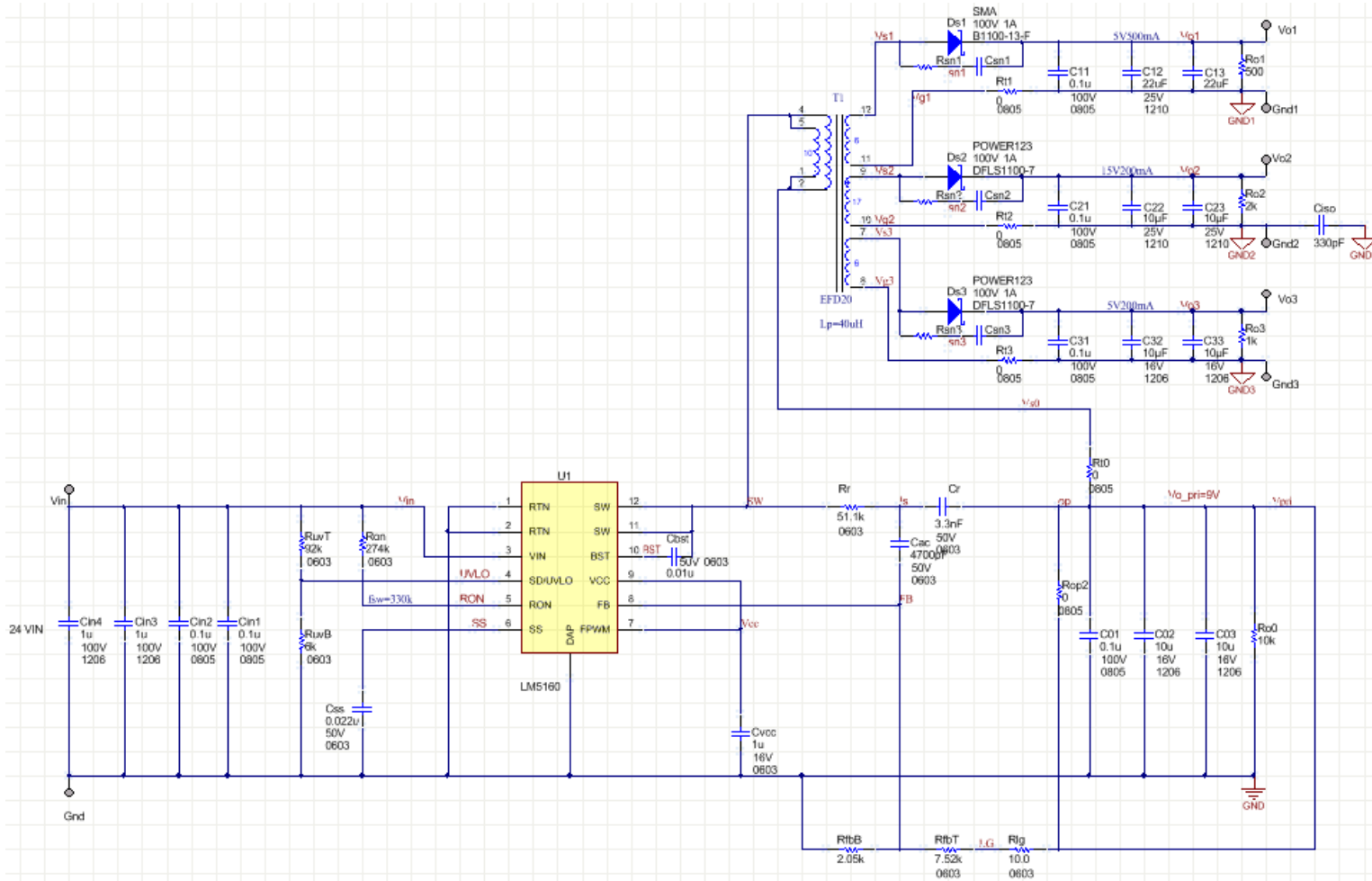

3) Typical Performances

3.1) Board and Thermal

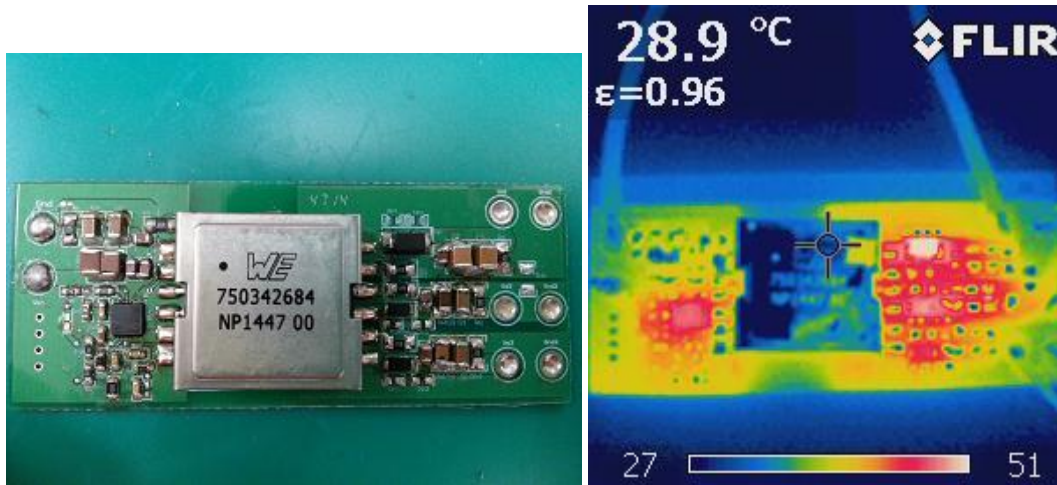

Board Dimensions: 80mm x 30mm

3.2) Efficiency and Cross Regulation

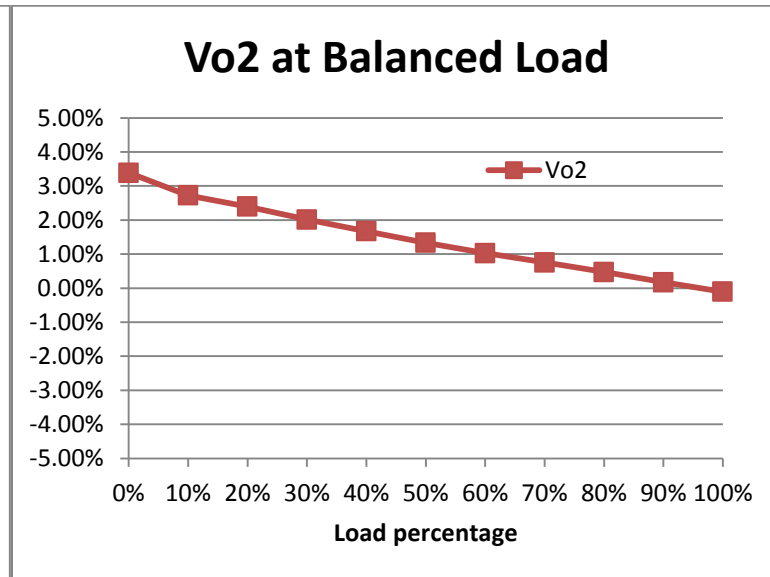
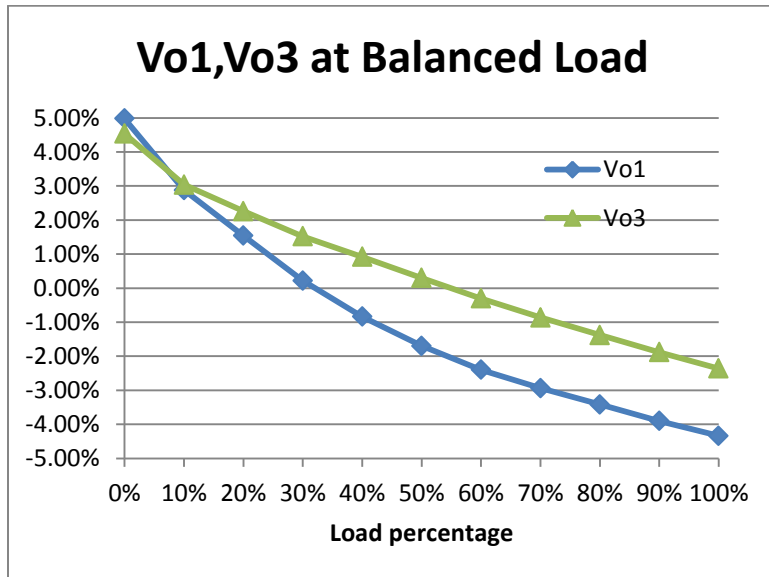
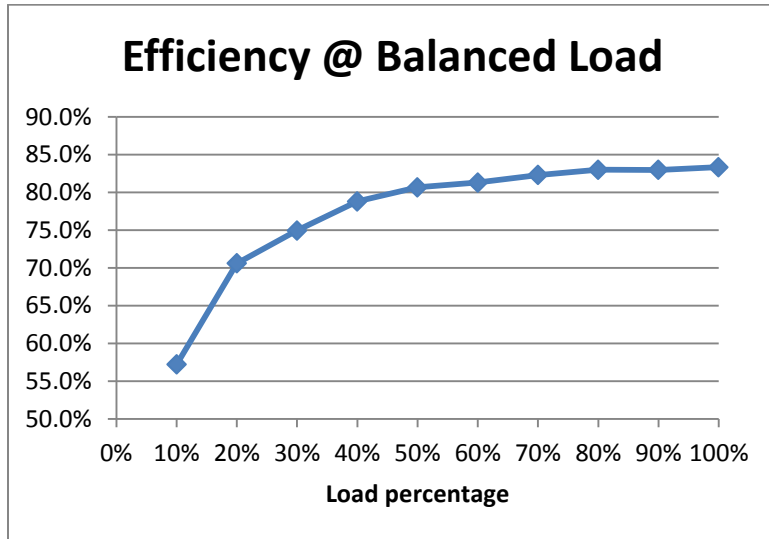

Vin	Iin	Vo1	Io1	Vo2	Io2	Vo3	Io3	Pst/eff.
V	mA	V	A	V	A	V	A	mW/%
24	19.2	5.249	0	15.508	0	5.227	0	462mW
24	48.7	5.144	0.05	15.409	0.02	5.152	0.02	57.2%
24	78.3	5.077	0.1	15.359	0.04	5.113	0.04	70.6%
24	109.8	5.011	0.15	15.302	0.06	5.076	0.06	74.9%
24	138.3	4.958	0.2	15.251	0.08	5.046	0.08	78.8%
24	167.9	4.915	0.25	15.200	0.1	5.015	0.1	80.7%
24	198.9	4.880	0.3	15.154	0.12	4.985	0.12	81.3%
24	228.3	4.853	0.35	15.113	0.14	4.957	0.14	82.3%
24	257.7	4.829	0.4	15.071	0.16	4.931	0.16	83.0%
24	288.8	4.805	0.45	15.026	0.18	4.906	0.18	83.0%
24	318.3	4.783	0.5	14.984	0.2	4.882	0.2	83.3%

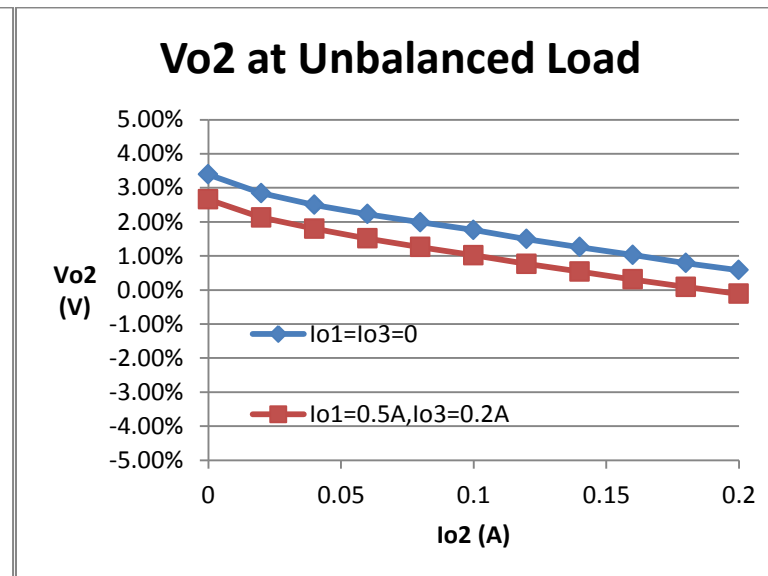
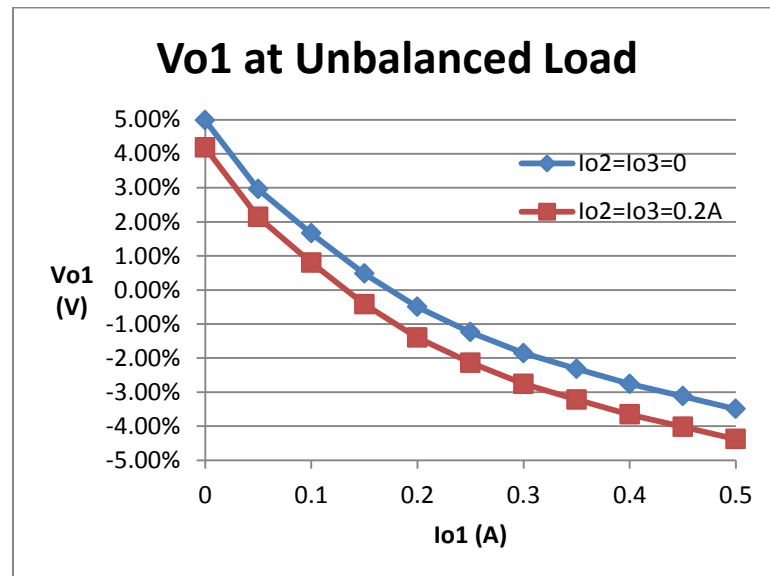

Vin	Iin	Vo1	Io1	Vo2	Io2	Vo3	Io3
V	mA	V	A	V	A	V	A
24	19.2	5.249	0	15.509	0	5.228	0
24	30.8	5.148	0.05	15.487	0	5.216	0
24	42.4	5.083	0.1	15.474	0	5.214	0
24	54.4	5.024	0.15	15.468	0	5.212	0
24	66.1	4.975	0.2	15.465	0	5.211	0
24	77.6	4.938	0.25	15.463	0	5.209	0
24	89.7	4.907	0.3	15.458	0	5.206	0
24	101.2	4.884	0.35	15.451	0	5.203	0
24	112.9	4.862	0.4	15.442	0	5.201	0
24	124.7	4.844	0.45	15.432	0	5.199	0
24	136.4	4.825	0.5	15.422	0	5.198	0
24	200.0	5.209	0	15.065	0.2	4.915	0.2
24	212.3	5.107	0.05	15.057	0.2	4.913	0.2
24	224.0	5.040	0.1	15.050	0.2	4.910	0.2
24	236.0	4.979	0.15	15.042	0.2	4.907	0.2
24	248.0	4.930	0.2	15.034	0.2	4.904	0.2
24	259.0	4.893	0.25	15.026	0.2	4.900	0.2
24	272.0	4.862	0.3	15.018	0.2	4.897	0.2
24	283.0	4.839	0.35	15.009	0.2	4.894	0.2
24	295.0	4.817	0.4	15.000	0.2	4.889	0.2
24	307.0	4.799	0.45	14.992	0.2	4.886	0.2
24	318.0	4.781	0.5	14.983	0.2	4.883	0.2
24	19.0	5.249	0	15.509	0	5.224	0
24	32.3	5.244	0	15.426	0.02	5.223	0
24	45.3	5.244	0	15.375	0.04	5.221	0
24	59.4	5.238	0	15.334	0.06	5.218	0
24	72.5	5.237	0	15.298	0.08	5.218	0

24	85.5	5.235	0	15.264	0.1	5.218	0
24	99.7	5.236	0	15.224	0.12	5.214	0
24	112.7	5.235	0	15.189	0.14	5.214	0
24	125.9	5.228	0	15.154	0.16	5.212	0
24	139.8	5.228	0	15.118	0.18	5.213	0
24	153.0	5.221	0	15.087	0.2	5.212	0
24	184.0	4.816	0.5	15.399	0	4.909	0.2
24	197.0	4.809	0.5	15.319	0.02	4.909	0.2
24	210.0	4.802	0.5	15.270	0.04	4.905	0.2
24	224.0	4.801	0.5	15.227	0.06	4.903	0.2
24	237.0	4.796	0.5	15.189	0.08	4.899	0.2
24	251.0	4.798	0.5	15.153	0.1	4.898	0.2
24	264.0	4.791	0.5	15.115	0.12	4.894	0.2
24	278.0	4.791	0.5	15.081	0.14	4.891	0.2
24	292.0	4.781	0.5	15.046	0.16	4.886	0.2
24	305.0	4.780	0.5	15.013	0.18	4.885	0.2
24	318.0	4.776	0.5	14.983	0.2	4.881	0.2

3.3) Dynamic Response

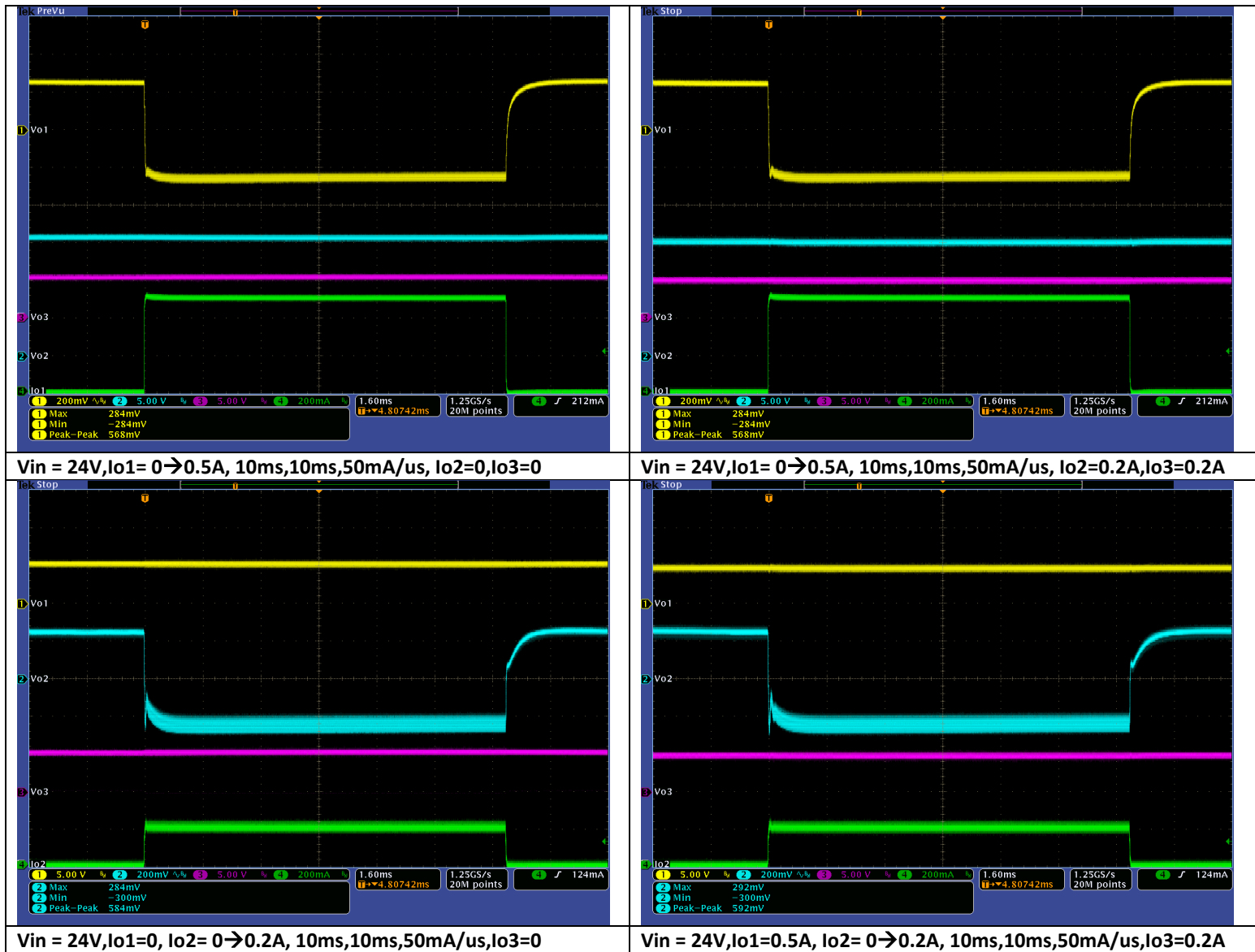

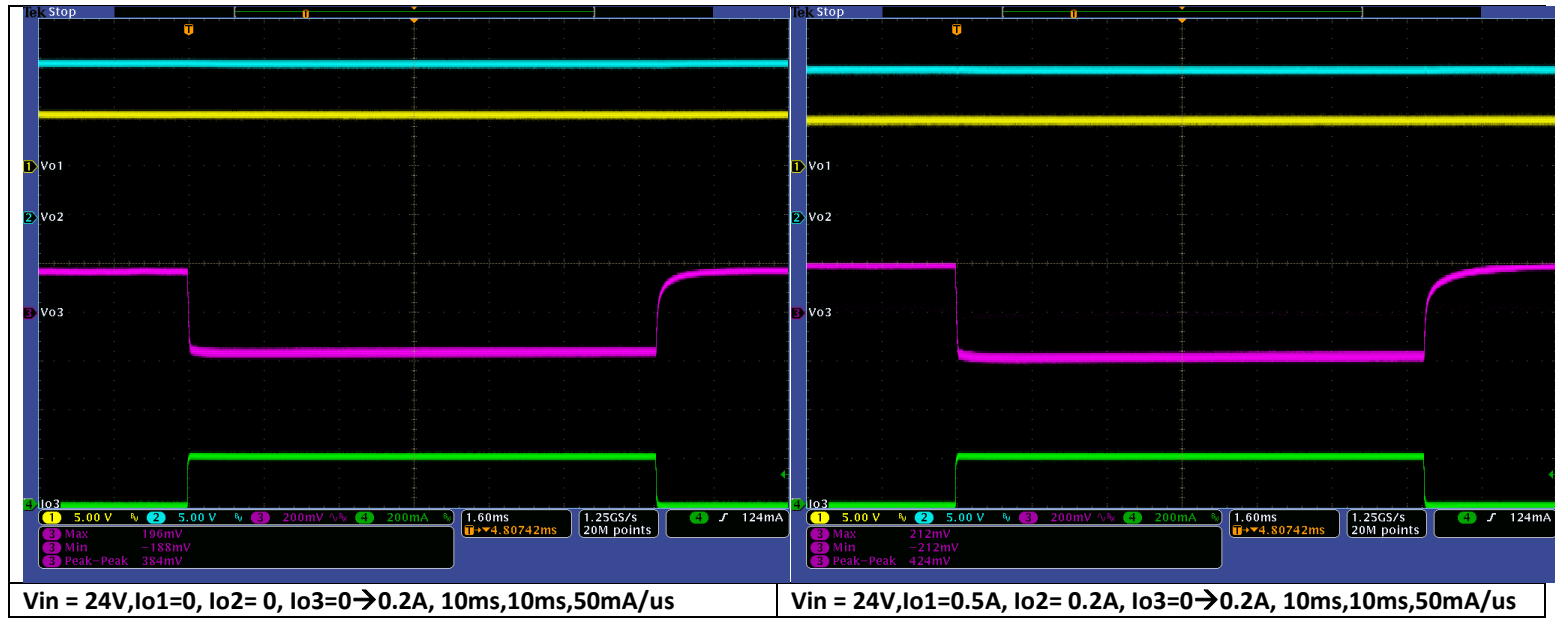

3.4) Start up and Shutdown

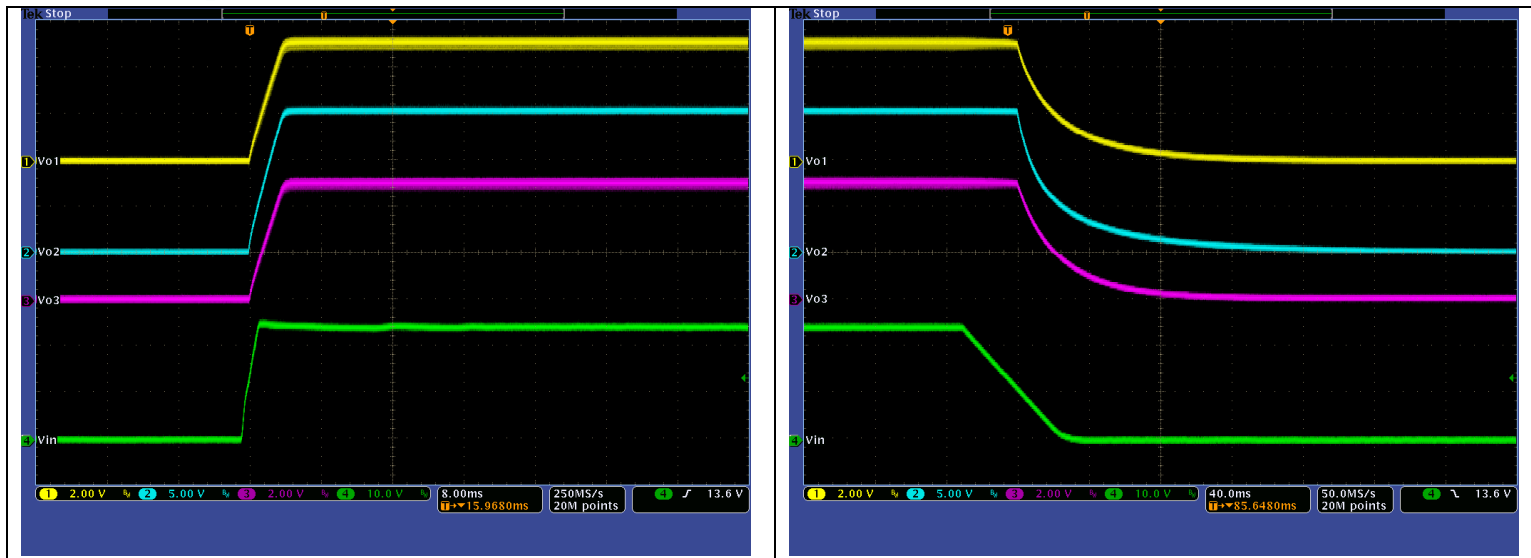

Vin = 24V, Io1=0, Io2= 0, Io3=0

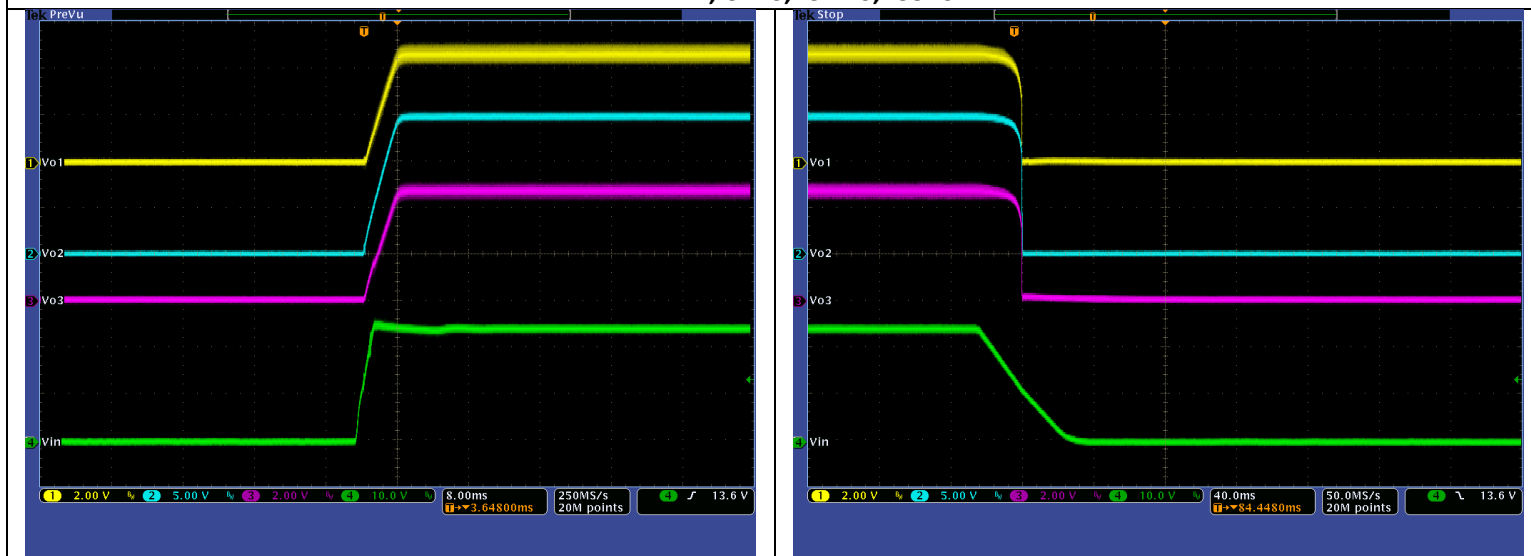

Vin = 24V, Io1=0.5A, Io2= 0.2A, Io3=0.2A

3.5) Output Ripple

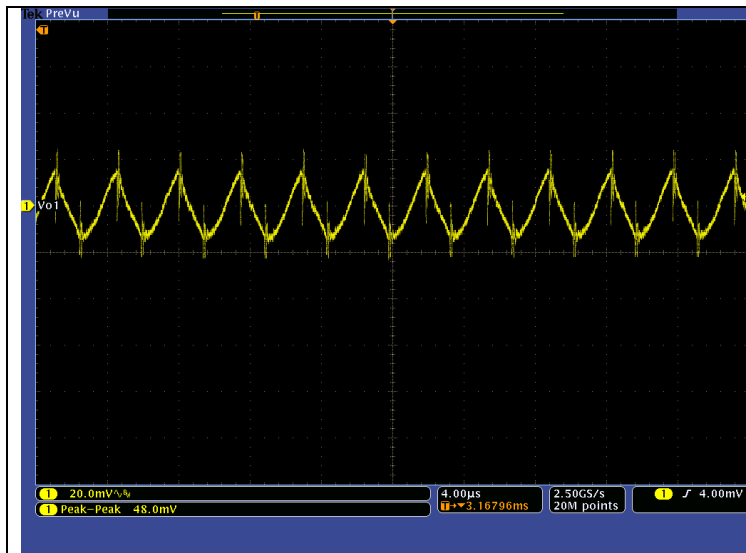

Vin = 24V, Io1=0.5A, Io2= 0, Io3=0

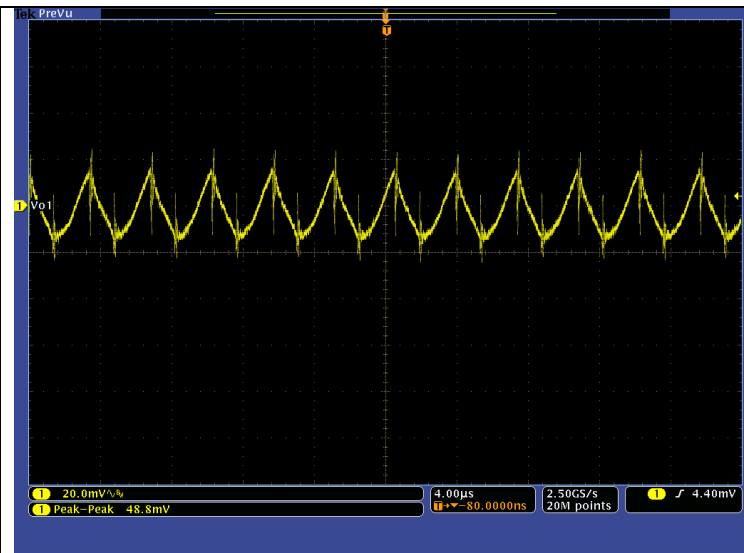

Vin = 24V, Io1=0.5A, Io2= 0.2A, Io3=0.2A

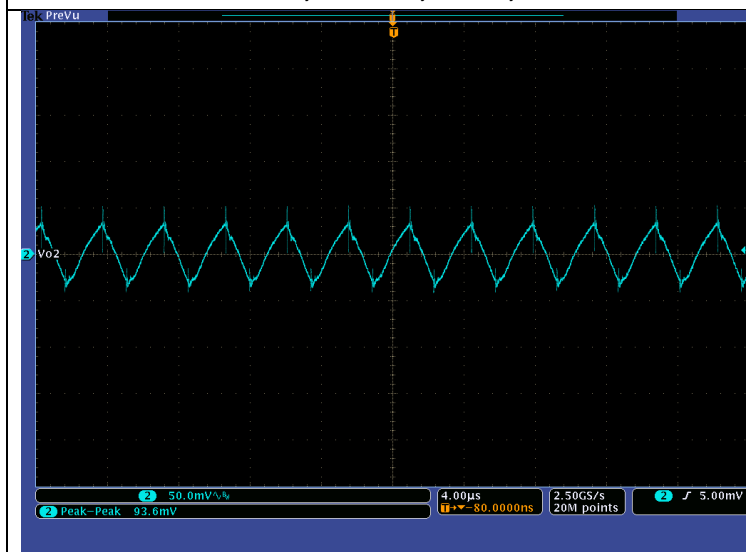

Vin = 24V, Io1=0, Io2= 0.2A, Io3=0

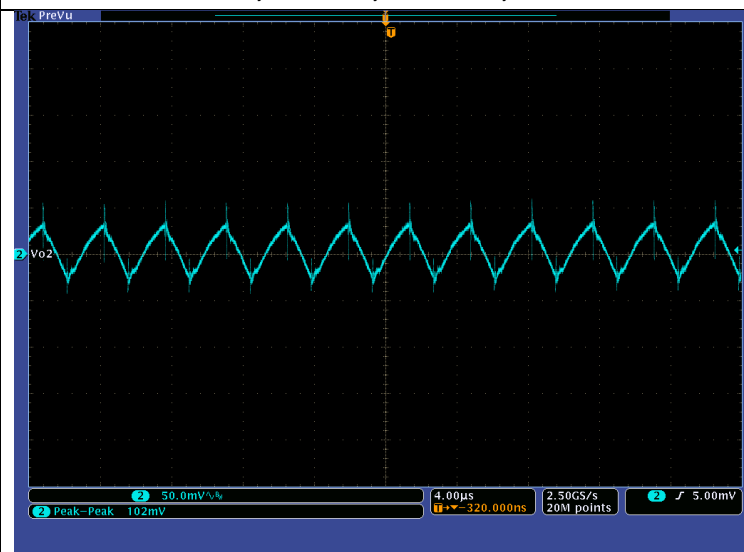

Vin = 24V, Io1=0.5A., Io2= 0.2A, Io3=0.2A

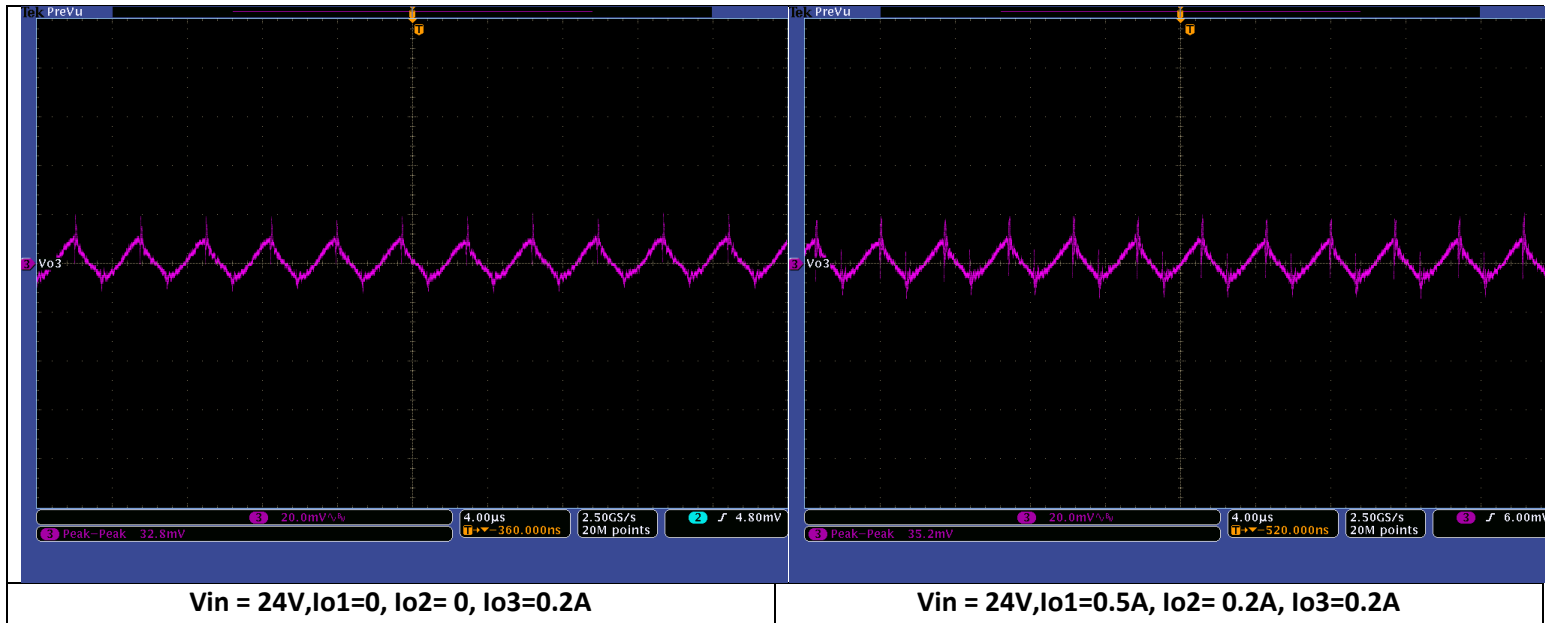

3.6) Primary Current, SW and secondary voltage of transformer

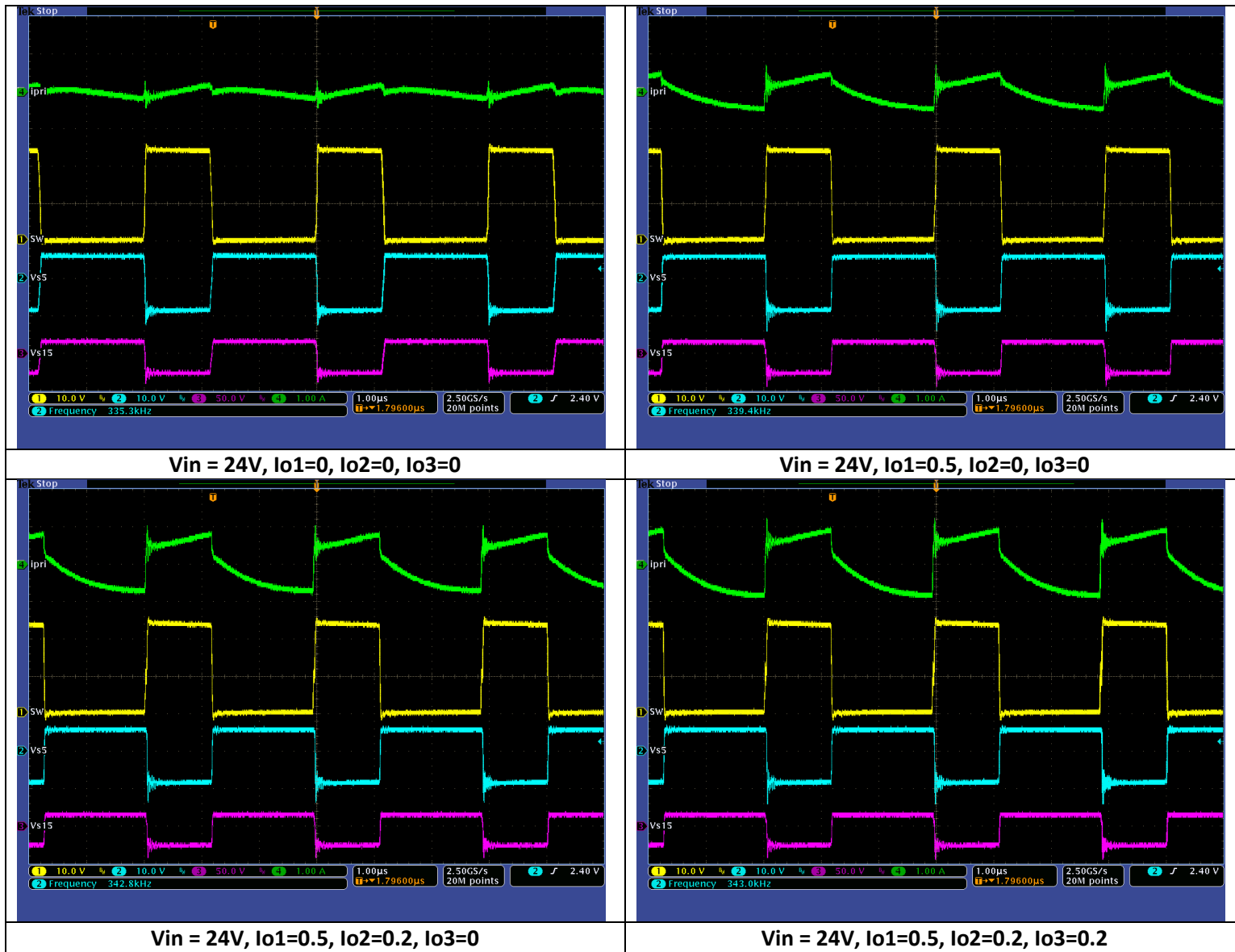

IMPORTANT NOTICE AND DISCLAIMER

TI PROVIDES TECHNICAL AND RELIABILITY DATA (INCLUDING DATA SHEETS), DESIGN RESOURCES (INCLUDING REFERENCE DESIGNS), APPLICATION OR OTHER DESIGN ADVICE, WEB TOOLS, SAFETY INFORMATION, AND OTHER RESOURCES "AS IS" AND WITH ALL FAULTS, AND DISCLAIMS ALL WARRANTIES, EXPRESS AND IMPLIED, INCLUDING WITHOUT LIMITATION ANY IMPLIED WARRANTIES OF MERCHANTABILITY, FITNESS FOR A PARTICULAR PURPOSE OR NON-INFRINGEMENT OF THIRD PARTY INTELLECTUAL PROPERTY RIGHTS.

These resources are intended for skilled developers designing with TI products. You are solely responsible for (1) selecting the appropriate TI products for your application, (2) designing, validating and testing your application, and (3) ensuring your application meets applicable standards, and any other safety, security, regulatory or other requirements.

These resources are subject to change without notice. TI grants you permission to use these resources only for development of an application that uses the TI products described in the resource. Other reproduction and display of these resources is prohibited. No license is granted to any other TI intellectual property right or to any third party intellectual property right. TI disclaims responsibility for, and you will fully indemnify TI and its representatives against, any claims, damages, costs, losses, and liabilities arising out of your use of these resources.

TI's products are provided subject to [TI's Terms of Sale](#) or other applicable terms available either on ti.com or provided in conjunction with such TI products. TI's provision of these resources does not expand or otherwise alter TI's applicable warranties or warranty disclaimers for TI products.

TI objects to and rejects any additional or different terms you may have proposed.

Mailing Address: Texas Instruments, Post Office Box 655303, Dallas, Texas 75265
Copyright © 2021, Texas Instruments Incorporated