

DRV3233-Q1 Automotive 24/12V Battery 3-Phase Gate Driver Unit With Accurate Current Sensing and Enhanced Diagnostics

1 Features

- AEC-Q100 qualified for automotive applications - Temperature options:
 - DRV3233E: -40°C to $+150^{\circ}\text{C}$, T_A
 - DRV3233Q: -40°C to $+125^{\circ}\text{C}$, T_A
- **Functional Safety-Compliant**
 - Developed for functional safety applications
 - Documentation to aid ISO 26262 system design available
 - Systematic capability up to ASIL D targeted
- Three phase half-bridge gate driver
 - Drives six N-channel MOSFETs (NMOS)
 - 4.5 to 60V wide operating voltage range
 - Bootstrap architecture for high-side gate driver
 - Charge pump for 50mA average gate current
 - 100% PWM duty cycle support
 - Overdrive supply of external switches
- Smart Gate Drive architecture
 - 45-level configurable peak gate drive current up to 1000 / 2000mA (source / sink)
 - Three-step dynamic drive current control
 - Soft shutdown for power stage protection
- Low-side Current Sense Amplifier
 - Sub-1mV low input offset across temperature
 - 9-level adjustable gain
- SPI-based detailed configuration and diagnostics
- DRVOFF pin to disable driver independently
- High voltage wake up pin (nSLEEP)
- Multiple PWM interface options available
 - 6x, 3x, 1x PWM Modes
 - PWM over SPI
- Supports 3.3V, and 5V Logic Inputs
- Optional programmable OTP for reset settings
- Advanced and configurable protection features
 - Battery and power supply voltage monitors
 - Phase feedback comparator
 - MOSFET V_{DS} and R_{sense} over current monitors
 - Analog Built-In-Self-Test, Clock monitors
 - Fault condition indicator pin

2 Applications

- 12V / 24V Automotive Motor-Control Applications
 - Electrical Power Steering and Steer-by-Wire
 - Electrical Mechanical Brake, Brake Boost Assist and Brake-by-Wire
 - Transmission and Shift-by-Wire
 - Automotive Pumps

3 Description

The DRV3233-Q1 is an integrated smart gate driver for 12V and 24V automotive three-phase BLDC applications. The device provides three half-bridge gate drivers, each capable of driving high-side and low-side N-channel power MOSFETs. The DRV3233-Q1 generates the correct gate drive voltages using an integrated bootstrap diode and a GVDD charge pump. The Smart Gate Drive architecture supports configurable peak gate drive current from 0.8mA up to 1A source and 2A sink. The DRV3233-Q1 can operate from a single power supply with a wide input range from 4.5 to 60V. A trickle charge pump enables 100% PWM duty cycle control, and provides overdrive supply voltage for external switches.

The DRV3233-Q1 provides low-side current sense amplifiers to support resistor based low-side current sensing. The low offset of the amplifiers enables the system to obtain precise motor current measurement.

A wide range of diagnostics and protection features integrated in the DRV3233-Q1 enable a robust motor drive system design and help eliminate the needs of external components. The highly configurable device response allows the device to be integrated seamlessly into a variety of system designs.

Package Information

| PART NUMBER | PACKAGE ⁽¹⁾ | PACKAGE SIZE (NOM) ⁽²⁾ | BODY SIZE (NOM) |
|-------------|-------------------------|-----------------------------------|-----------------|
| DRV3233-Q1 | HTQFP (48) | 9mm x 9mm | 7mm x 7mm |
| | QFN (48) | 7mm x 7mm | 7mm x 7mm |
| | QFN (32) ⁽³⁾ | 6mm x 4mm | 6mm x 4mm |

- (1) For all available packages, see the orderable addendum at the end of the data sheet.
- (2) The package size (length x width) is a nominal value and includes pins, where applicable.
- (3) Product preview only. Contact TI for more information.



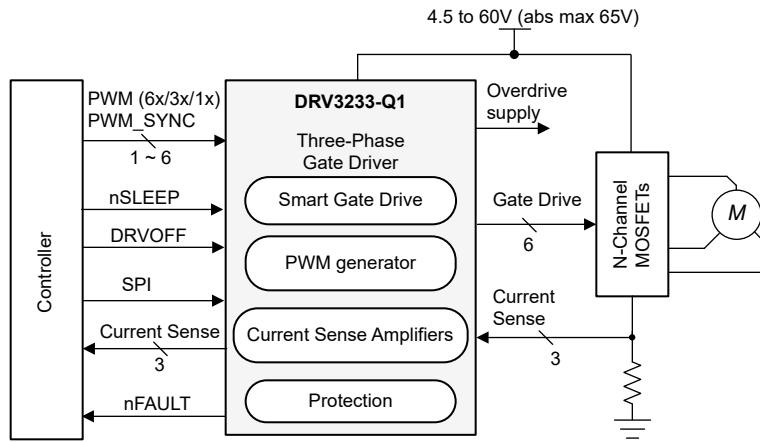

Simplified Schematic

Table of Contents

| | | | |
|-----------------------------|----------|--|----------|
| 1 Features | 1 | 4 Revision History | 3 |
| 2 Applications | 1 | 5 Mechanical, Packaging, and Orderable Information | 4 |
| 3 Description | 1 | | |

4 Revision History

NOTE: Page numbers for previous revisions may differ from page numbers in the current version.

| | |
|--|-------------|
| Changes from Revision E (January 2026) to Revision F (May 2026) | Page |
|--|-------------|

- | | |
|--|---|
| • Updated the device status for DRV3233ERRY to preview data..... | 4 |
|--|---|
-

| | |
|--|-------------|
| Changes from Revision D (January 2026) to Revision E (May 2026) | Page |
|--|-------------|

- | | |
|---|---|
| • Updated the device status for DRV3233ERGZ to production data..... | 4 |
|---|---|
-

| | |
|--|-------------|
| Changes from Revision C (July 2025) to Revision D (December 2025) | Page |
|--|-------------|

- | | |
|---|---|
| • Updated Functional Safety Compliant status to reflect completion of Functional Safety Assessment..... | 1 |
| • Added orderable part number for DRV3233QRGZ..... | 1 |
-

| | |
|---|-------------|
| Changes from Revision B (March 2025) to Revision C (July 2025) | Page |
|---|-------------|

- | | |
|--|---|
| • Updated the device status for DRV3233ERGZ to preview data..... | 4 |
|--|---|
-

| | |
|--|-------------|
| Changes from Revision A (August 2024) to Revision B (July 2025) | Page |
|--|-------------|

- | | |
|---|---|
| • Updated the device status for DRV3233QPHP to production data..... | 4 |
|---|---|
-

| | |
|---|-------------|
| Changes from Revision * (September 2023) to Revision A (August 2024) | Page |
|---|-------------|

- | | |
|---|---|
| • Updated the device status for DRV3233EPHP to production data..... | 1 |
|---|---|
-

5 Mechanical, Packaging, and Orderable Information

The following pages include mechanical, packaging, and orderable information. This information is the most current data available for the designated devices. This data is subject to change without notice and revision of this document. For browser-based versions of this data sheet, refer to the left-hand navigation.

PACKAGING INFORMATION

| Orderable part number | Status (1) | Material type (2) | Package Pins | Package qty Carrier | RoHS (3) | Lead finish/ Ball material (4) | MSL rating/ Peak reflow (5) | Op temp (°C) | Part marking (6) |
|---------------------------------|---------------|----------------------|------------------|-----------------------|-------------|--------------------------------------|-----------------------------------|--------------|---------------------|
| DRV3233EPHPRQ1 | Active | Production | HTQFP (PHP) 48 | 1000 LARGE T&R | Yes | NIPDAU | Level-3-260C-168 HR | -40 to 150 | DRV3233E |
| DRV3233EPHPRQ1.A | Active | Production | HTQFP (PHP) 48 | 1000 LARGE T&R | Yes | NIPDAU | Level-3-260C-168 HR | -40 to 150 | DRV3233E |
| DRV3233ERGZRQ1 | Active | Production | VQFN (RGZ) 48 | 4000 LARGE T&R | Yes | NIPDAU | Level-3-260C-168 HR | -40 to 150 | DRV3233 ERGZ Q1 |
| DRV3233QPHPRQ1 | Active | Production | HTQFP (PHP) 48 | 1000 LARGE T&R | Yes | NIPDAU | Level-3-260C-168 HR | -40 to 125 | DRV3233Q |
| DRV3233QPHPRQ1.A | Active | Production | HTQFP (PHP) 48 | 1000 LARGE T&R | Yes | NIPDAU | Level-3-260C-168 HR | -40 to 125 | DRV3233Q |
| DRV3233QRGZRQ1 | Active | Production | VQFN (RGZ) 48 | 4000 LARGE T&R | Yes | NIPDAU | Level-3-260C-168 HR | -40 to 150 | DRV3233 QRGZ Q1 |
| PDRV3233ERRYRQ1 | Active | Preproduction | WQFN (RRY) 32 | 3000 LARGE T&R | - | Call TI | Call TI | -40 to 150 | |

(1) **Status:** For more details on status, see our [product life cycle](#).

(2) **Material type:** When designated, preproduction parts are prototypes/experimental devices, and are not yet approved or released for full production. Testing and final process, including without limitation quality assurance, reliability performance testing, and/or process qualification, may not yet be complete, and this item is subject to further changes or possible discontinuation. If available for ordering, purchases will be subject to an additional waiver at checkout, and are intended for early internal evaluation purposes only. These items are sold without warranties of any kind.

(3) **RoHS values:** Yes, No, RoHS Exempt. See the [TI RoHS Statement](#) for additional information and value definition.

(4) **Lead finish/Ball material:** Parts may have multiple material finish options. Finish options are separated by a vertical ruled line. Lead finish/Ball material values may wrap to two lines if the finish value exceeds the maximum column width.

(5) **MSL rating/Peak reflow:** The moisture sensitivity level ratings and peak solder (reflow) temperatures. In the event that a part has multiple moisture sensitivity ratings, only the lowest level per JEDEC standards is shown. Refer to the shipping label for the actual reflow temperature that will be used to mount the part to the printed circuit board.

(6) **Part marking:** There may be an additional marking, which relates to the logo, the lot trace code information, or the environmental category of the part.

Multiple part markings will be inside parentheses. Only one part marking contained in parentheses and separated by a "-" will appear on a part. If a line is indented then it is a continuation of the previous line and the two combined represent the entire part marking for that device.

Important Information and Disclaimer: The information provided on this page represents TI's knowledge and belief as of the date that it is provided. TI bases its knowledge and belief on information provided by third parties, and makes no representation or warranty as to the accuracy of such information. Efforts are underway to better integrate information from third parties. TI has taken and continues to take reasonable steps to provide representative and accurate information but may not have conducted destructive testing or chemical analysis on incoming materials and chemicals. TI and TI suppliers consider certain information to be proprietary, and thus CAS numbers and other limited information may not be available for release.

In no event shall TI's liability arising out of such information exceed the total purchase price of the TI part(s) at issue in this document sold by TI to Customer on an annual basis.

TAPE AND REEL INFORMATION

QUADRANT ASSIGNMENTS FOR PIN 1 ORIENTATION IN TAPE

*All dimensions are nominal

| Device | Package Type | Package Drawing | Pins | SPQ | Reel Diameter (mm) | Reel Width W1 (mm) | A0 (mm) | B0 (mm) | K0 (mm) | P1 (mm) | W (mm) | Pin1 Quadrant |
|----------------|--------------|-----------------|------|------|--------------------|--------------------|---------|---------|---------|---------|--------|---------------|
| DRV3233EPHRQ1 | HTQFP | PHP | 48 | 1000 | 330.0 | 16.4 | 9.6 | 9.6 | 1.5 | 12.0 | 16.0 | Q2 |
| DRV3233ERGZRQ1 | VQFN | RGZ | 48 | 4000 | 330.0 | 16.4 | 7.3 | 7.3 | 1.1 | 12.0 | 16.0 | Q2 |
| DRV3233QPHPRQ1 | HTQFP | PHP | 48 | 1000 | 330.0 | 16.4 | 9.6 | 9.6 | 1.5 | 12.0 | 16.0 | Q2 |
| DRV3233QRGZRQ1 | VQFN | RGZ | 48 | 4000 | 330.0 | 16.4 | 7.3 | 7.3 | 1.1 | 12.0 | 16.0 | Q2 |

TAPE AND REEL BOX DIMENSIONS



*All dimensions are nominal

| Device | Package Type | Package Drawing | Pins | SPQ | Length (mm) | Width (mm) | Height (mm) |
|----------------|--------------|-----------------|------|------|-------------|------------|-------------|
| DRV3233EPHPRQ1 | HTQFP | PHP | 48 | 1000 | 336.6 | 336.6 | 31.8 |
| DRV3233ERGZRQ1 | VQFN | RGZ | 48 | 4000 | 367.0 | 367.0 | 38.0 |
| DRV3233QPHPRQ1 | HTQFP | PHP | 48 | 1000 | 336.6 | 336.6 | 31.8 |
| DRV3233QRGZRQ1 | VQFN | RGZ | 48 | 4000 | 367.0 | 367.0 | 38.0 |

GENERIC PACKAGE VIEW

RRY 32

WQFN - 0.8 mm max height

4 x 6, 0.5 mm pitch

PLASTIC QUAD FLATPACK - NO LEAD

This image is a representation of the package family, actual package may vary.
Refer to the product data sheet for package details.

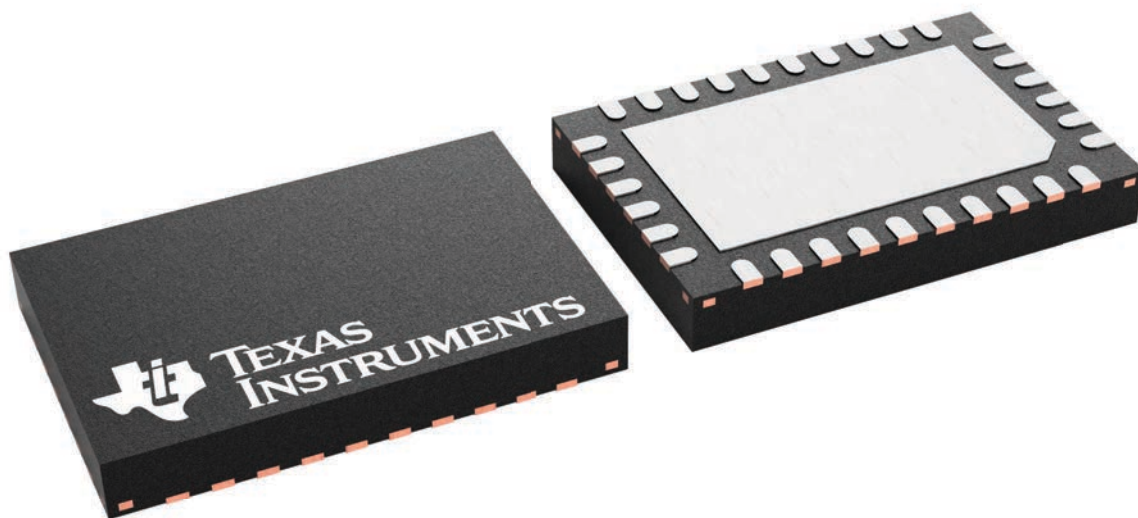

4229624/A

GENERIC PACKAGE VIEW

RGZ 48

VQFN - 1 mm max height

7 x 7, 0.5 mm pitch

PLASTIC QUADFLAT PACK- NO LEAD

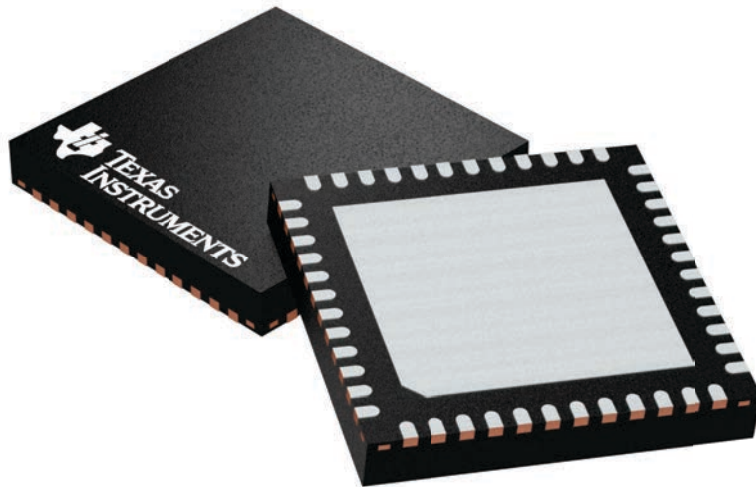

Images above are just a representation of the package family, actual package may vary.
Refer to the product data sheet for package details.

4224671/A

RGZ0048M

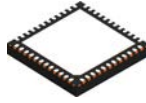

PACKAGE OUTLINE

VQFN - 1 mm max height

PLASTIC QUAD FLATPACK - NO LEAD

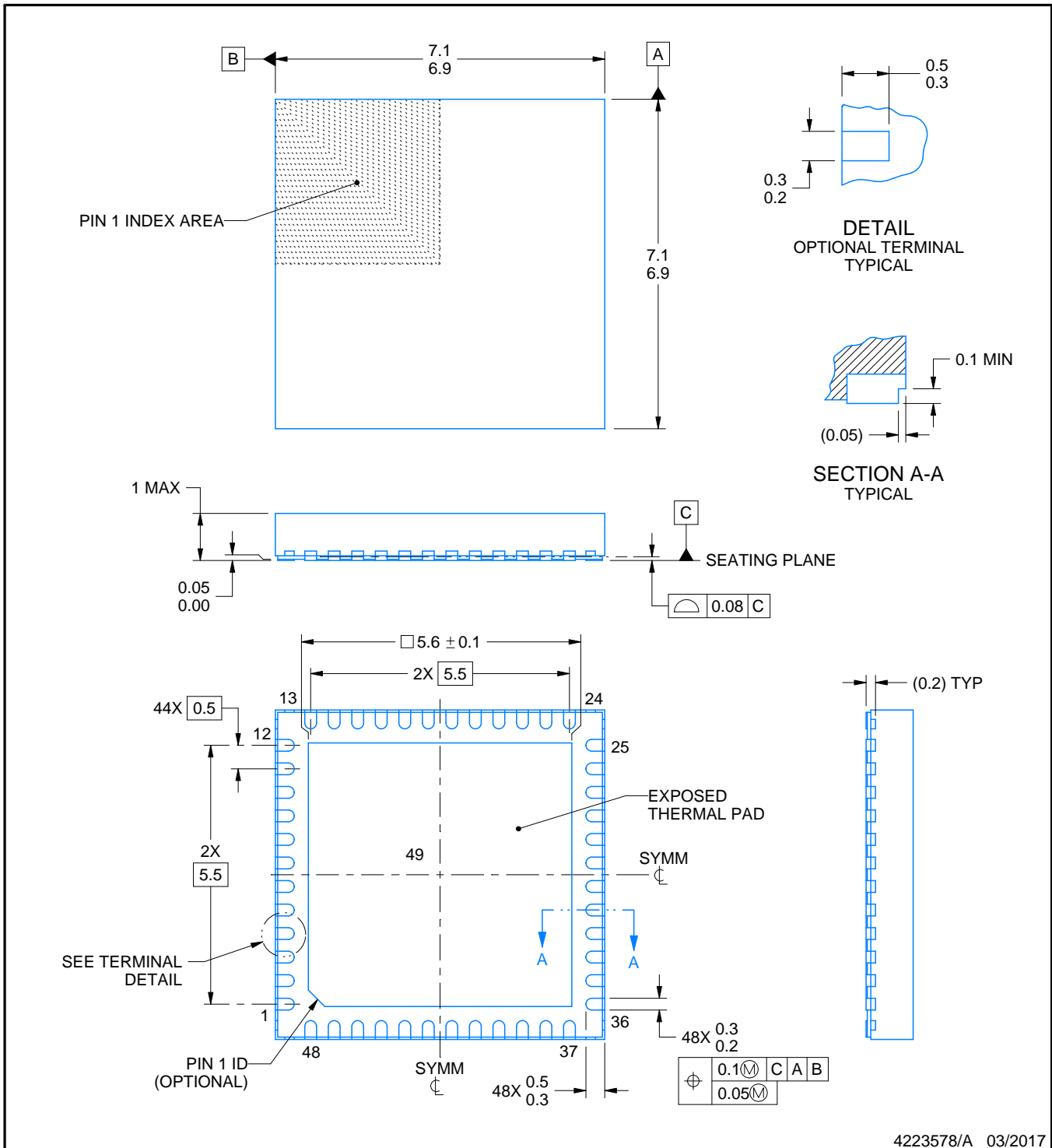

4223578/A 03/2017

NOTES:

1. All linear dimensions are in millimeters. Any dimensions in parenthesis are for reference only. Dimensioning and tolerancing per ASME Y14.5M.
2. This drawing is subject to change without notice.
3. The package thermal pad must be soldered to the printed circuit board for thermal and mechanical performance.

EXAMPLE BOARD LAYOUT

RGZ0048M

VQFN - 1 mm max height

PLASTIC QUAD FLATPACK - NO LEAD

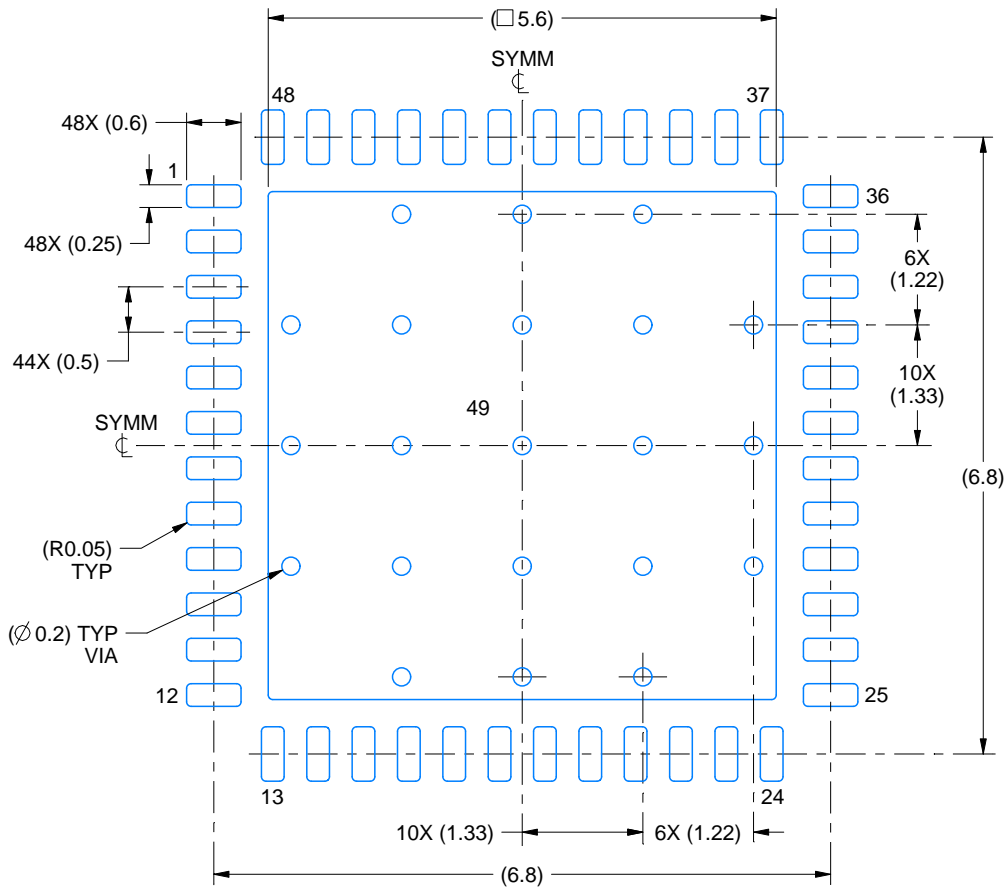

LAND PATTERN EXAMPLE
EXPOSED METAL SHOWN
SCALE:12X

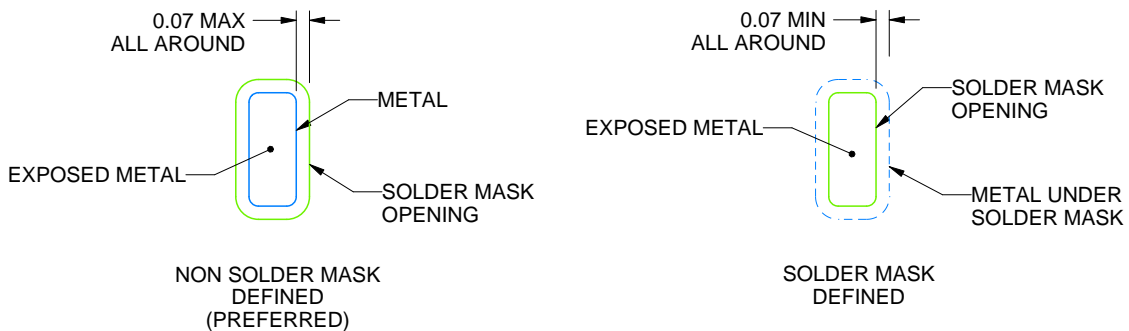

SOLDER MASK DETAILS

4223578/A 03/2017

NOTES: (continued)

- This package is designed to be soldered to a thermal pad on the board. For more information, see Texas Instruments literature number SLUA271 (www.ti.com/lit/slua271).
- Vias are optional depending on application, refer to device data sheet. If any vias are implemented, refer to their locations shown on this view. It is recommended that vias under paste be filled, plugged or tented.

EXAMPLE STENCIL DESIGN

RGZ0048M

VQFN - 1 mm max height

PLASTIC QUAD FLATPACK - NO LEAD

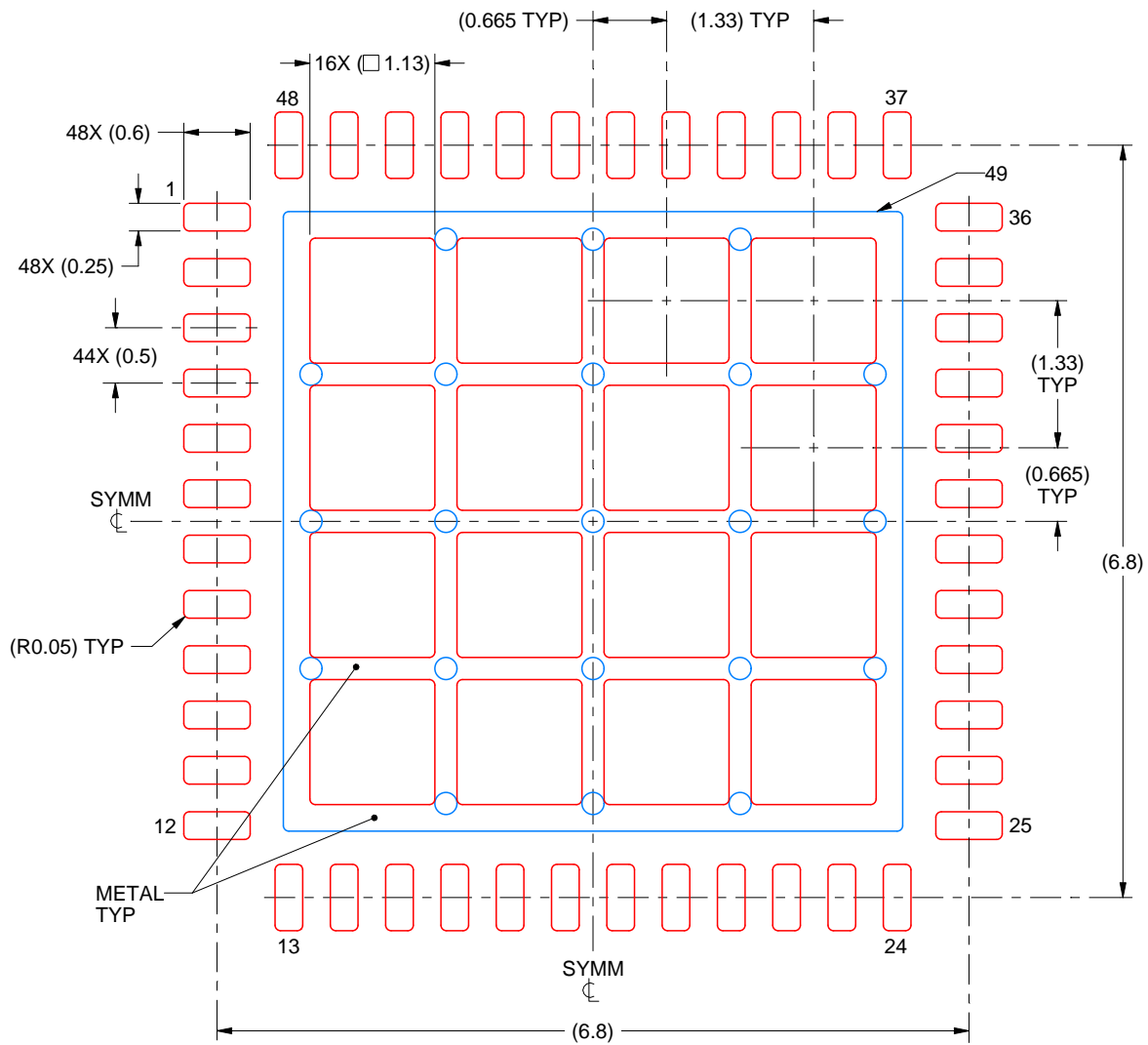

SOLDER PASTE EXAMPLE
BASED ON 0.125 mm THICK STENCIL

EXPOSED PAD 49
66% PRINTED SOLDER COVERAGE BY AREA UNDER PACKAGE
SCALE:15X

4223578/A 03/2017

NOTES: (continued)

6. Laser cutting apertures with trapezoidal walls and rounded corners may offer better paste release. IPC-7525 may have alternate design recommendations.

GENERIC PACKAGE VIEW

PHP 48

TQFP - 1.2 mm max height

7 x 7, 0.5 mm pitch

QUAD FLATPACK

This image is a representation of the package family, actual package may vary.
Refer to the product data sheet for package details.

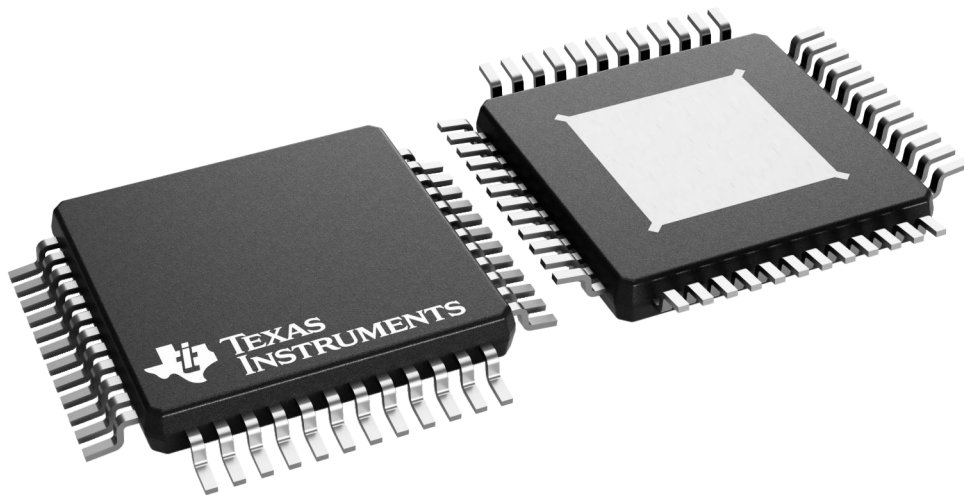

4226443/A

PHP0048P

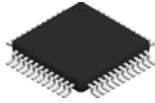

PACKAGE OUTLINE

PowerPAD™ HTQFP - 1.2 mm max height

PLASTIC QUAD FLATPACK

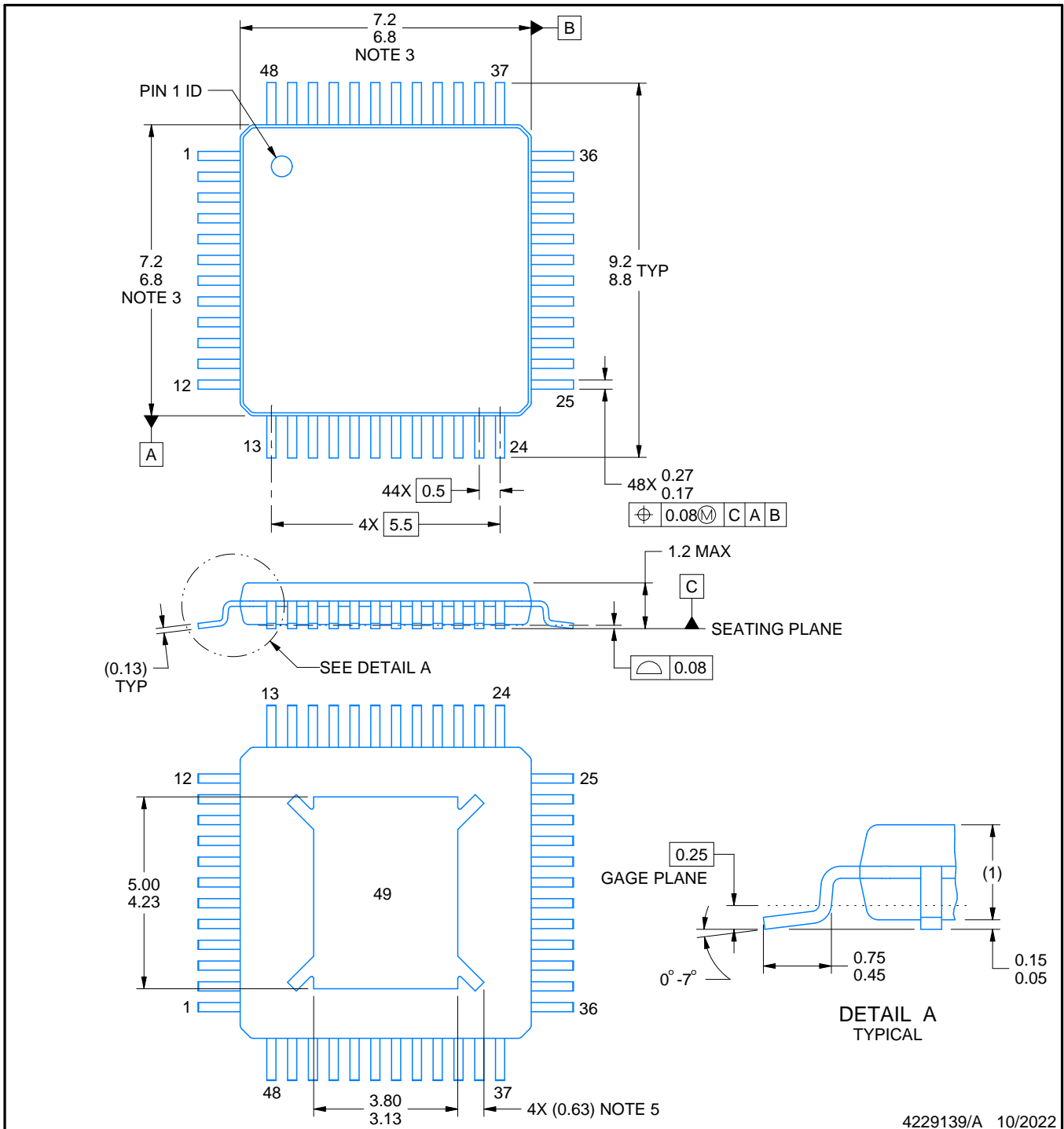

4229139/A 10/2022

PowerPAD is a trademark of Texas Instruments.

NOTES:

1. All linear dimensions are in millimeters. Any dimensions in parenthesis are for reference only. Dimensioning and tolerancing per ASME Y14.5M.
2. This drawing is subject to change without notice.
3. This dimension does not include mold flash, protrusions, or gate burrs. Mold flash, protrusions, or gate burrs shall not exceed 0.15 mm per side.
4. Reference JEDEC registration MS-026.
5. Feature may not be present.

EXAMPLE BOARD LAYOUT

PHP0048P

PowerPAD™ HTQFP - 1.2 mm max height

PLASTIC QUAD FLATPACK

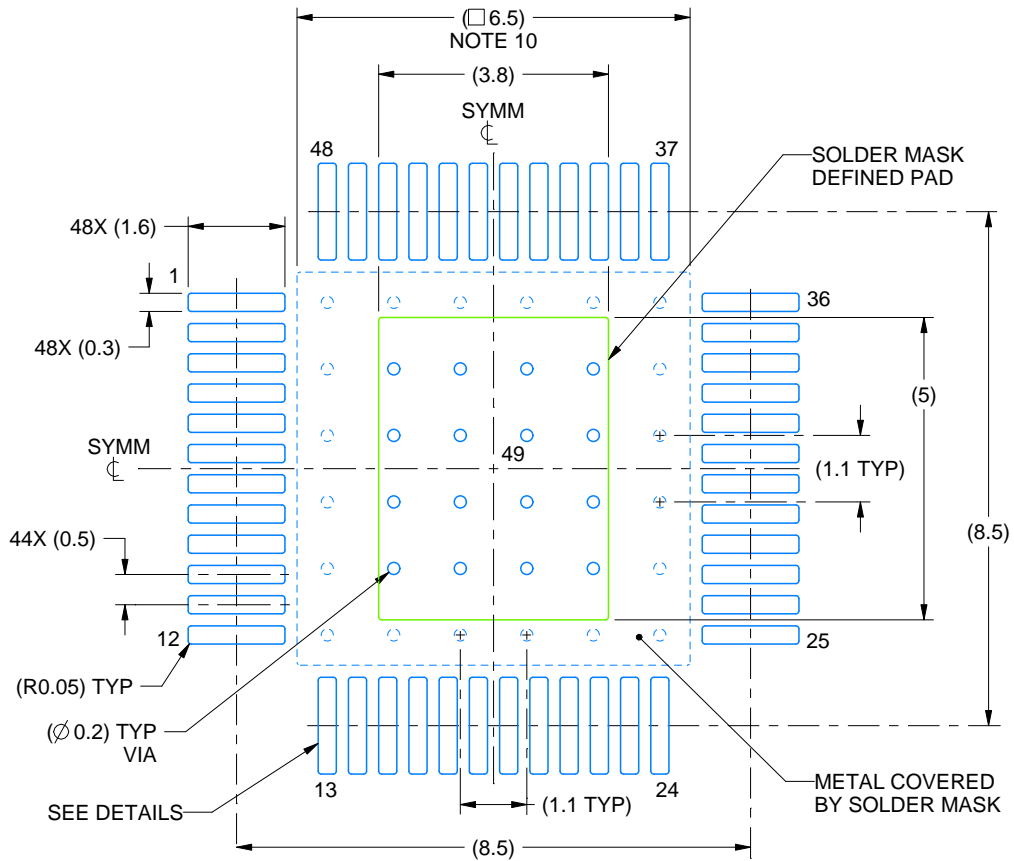

LAND PATTERN EXAMPLE
EXPOSED METAL SHOWN
SCALE:8X

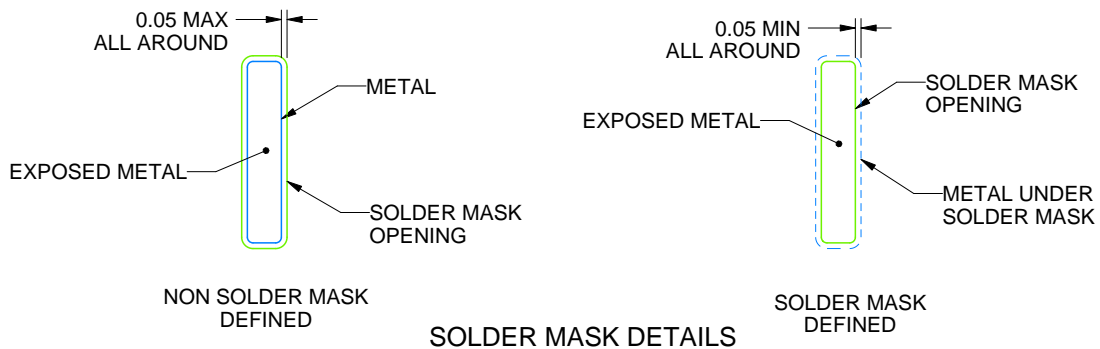

4229139/A 10/2022

NOTES: (continued)

6. Publication IPC-7351 may have alternate designs.
7. Solder mask tolerances between and around signal pads can vary based on board fabrication site.
8. This package is designed to be soldered to a thermal pad on the board. See technical brief, Powerpad thermally enhanced package, Texas Instruments Literature No. SLMA002 (www.ti.com/lit/slma002) and SLMA004 (www.ti.com/lit/slma004).
9. Vias are optional depending on application, refer to device data sheet. It is recommended that vias under paste be filled, plugged or tented.
10. Size of metal pad may vary due to creepage requirement.

EXAMPLE STENCIL DESIGN

PHP0048P

PowerPAD™ HTQFP - 1.2 mm max height

PLASTIC QUAD FLATPACK

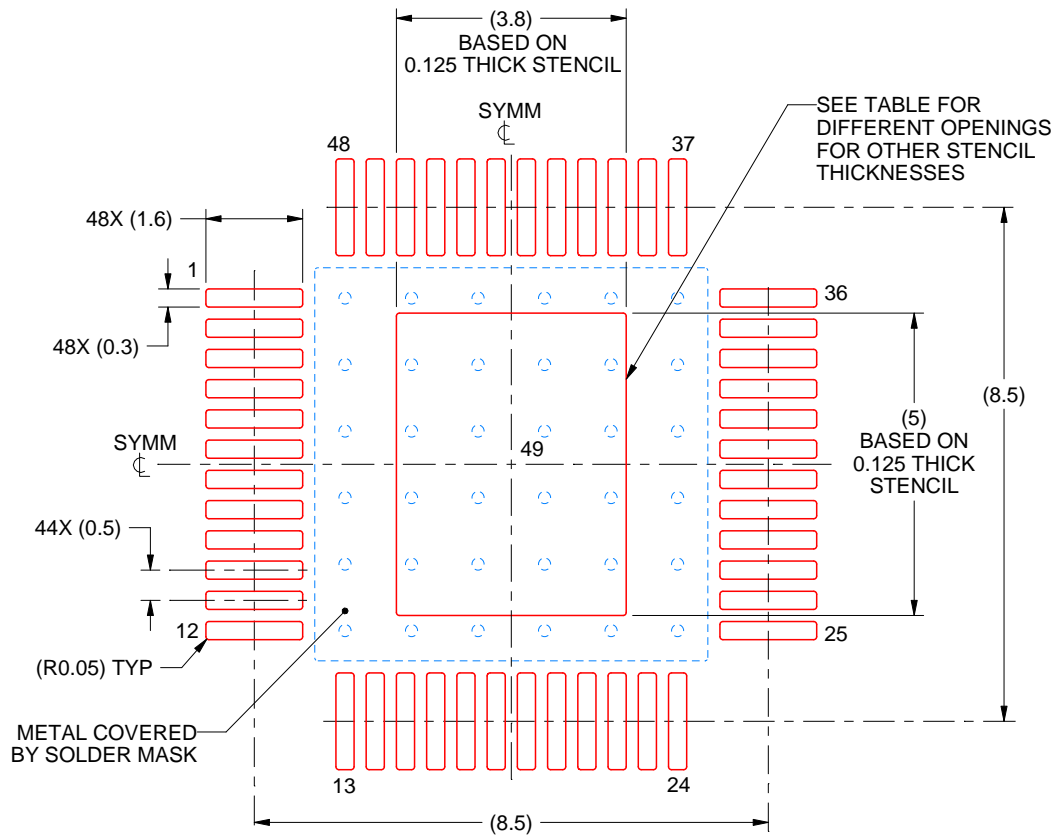

SOLDER PASTE EXAMPLE
EXPOSED PAD
100% PRINTED SOLDER COVERAGE BY AREA
SCALE:8X

| STENCIL THICKNESS | SOLDER STENCIL OPENING |
|-------------------|------------------------|
| 0.1 | 4.25 X 5.59 |
| 0.125 | 3.80 X 5.00 (SHOWN) |
| 0.150 | 3.47 X 4.56 |
| 0.175 | 3.21 X 4.23 |

4229139/A 10/2022

NOTES: (continued)

11. Laser cutting apertures with trapezoidal walls and rounded corners may offer better paste release. IPC-7525 may have alternate design recommendations.
12. Board assembly site may have different recommendations for stencil design.

IMPORTANT NOTICE AND DISCLAIMER

TI PROVIDES TECHNICAL AND RELIABILITY DATA (INCLUDING DATASHEETS), DESIGN RESOURCES (INCLUDING REFERENCE DESIGNS), APPLICATION OR OTHER DESIGN ADVICE, WEB TOOLS, SAFETY INFORMATION, AND OTHER RESOURCES "AS IS" AND WITH ALL FAULTS, AND DISCLAIMS ALL WARRANTIES, EXPRESS AND IMPLIED, INCLUDING WITHOUT LIMITATION ANY IMPLIED WARRANTIES OF MERCHANTABILITY, FITNESS FOR A PARTICULAR PURPOSE OR NON-INFRINGEMENT OF THIRD PARTY INTELLECTUAL PROPERTY RIGHTS.

These resources are intended for skilled developers designing with TI products. You are solely responsible for (1) selecting the appropriate TI products for your application, (2) designing, validating and testing your application, and (3) ensuring your application meets applicable standards, and any other safety, security, regulatory or other requirements.

These resources are subject to change without notice. TI grants you permission to use these resources only for development of an application that uses the TI products described in the resource. Other reproduction and display of these resources is prohibited. No license is granted to any other TI intellectual property right or to any third party intellectual property right. TI disclaims responsibility for, and you fully indemnify TI and its representatives against any claims, damages, costs, losses, and liabilities arising out of your use of these resources.

TI's products are provided subject to [TI's Terms of Sale](#), [TI's General Quality Guidelines](#), or other applicable terms available either on ti.com or provided in conjunction with such TI products. TI's provision of these resources does not expand or otherwise alter TI's applicable warranties or warranty disclaimers for TI products. Unless TI explicitly designates a product as custom or customer-specified, TI products are standard, catalog, general purpose devices.

TI objects to and rejects any additional or different terms you may propose.

Copyright © 2026, Texas Instruments Incorporated

Last updated 10/2025