

LM98714 Three Channel, 16-Bit, 45 MSPS Analog Front End With LVDS/CMOS Output and Integrated CCD/CIS Sensor Timing Generator

1 Features

- LVDS/CMOS Outputs
- LVDS/CMOS Pixel Rate Input Clock or ADC Input Clock
- CDS or S/H Processing for CCD or CIS Sensors
- Independent Gain/Offset Correction for Each Channel
- Digital Black Level Correction Loop for Each Channel
- Programmable Input Clamp Voltage
- Flexible CCD/CIS Sensor Timing Generator
- Key Specifications
 - Maximum Input Level: 1.2 or 2.4 Volt Modes
 - (Both with + or – Polarity Option)
 - ADC Resolution: 16-Bit
 - ADC Sampling Rate: 45 MSPS
 - INL: ± 23 LSB (Typ)
 - Channel Sampling Rate: 15/22.5/30 MSPS
 - PGA Gain Steps: 256 Steps
 - PGA Gain Range: 0.7 to 7.84x
 - Analog DAC Resolution: ± 9 Bits
 - Analog DAC Range: ± 300 mV or ± 600 mV
 - Digital DAC Resolution: ± 6 Bits
 - Digital DAC Range: -1024 LSB to $+1008$ LSB
 - SNR: -74 dB (at 0 dB PGA Gain)
 - Power Dissipation: 505 mW (LVDS) 610 mW (CMOS)
 - Operating Temp: 0 to 70°C
 - Supply Voltage: 3.3 V Nominal (3.0 V to 3.6 V Range)

2 Applications

- Multi-Function Peripherals
- Facsimile Equipment
- Flatbed or Handheld Color Scanners
- High-Speed Document Scanner

3 Description

The LM98714 is a fully integrated, high performance 16-Bit, 45 MSPS signal processing solution for digital color copiers, scanners, and other image processing applications. High-speed signal throughput is achieved with an innovative architecture utilizing Correlated Double Sampling (CDS), typically employed with CCD arrays, or Sample and Hold (S/H) inputs (for Contact Image Sensors and CMOS image sensors). The signal paths utilize 8 bit Programmable Gain Amplifiers (PGA), a ± 9 -Bit offset correction DAC and independently controlled Digital Black Level correction loops for each input. The PGA and offset DAC are programmed independently allowing unique values of gain and offset for each of the three inputs. The signals are then routed to a 45 MHz high performance analog-to-digital converter (ADC). The fully differential processing channel shows exceptional noise immunity, having a very low noise floor of -74 dB. The 16-bit ADC has excellent dynamic performance making the LM98714 transparent in the image reproduction chain.

Device Information⁽¹⁾

PART NUMBER	PACKAGE	BODY SIZE (NOM)
LM98714	TSSOP (48)	12.50 mm x 6.1 mm

(1) For all available packages, see the orderable addendum at the end of the data sheet.

System Block Diagram

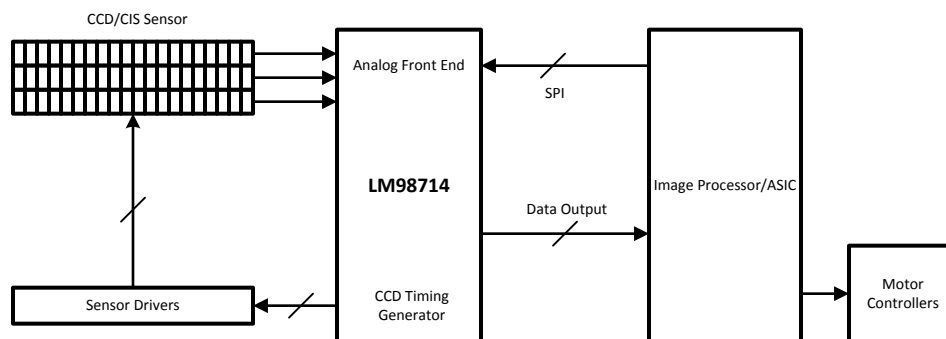

Table of Contents

1 Features 1 2 Applications 1 3 Description 1 4 Revision History 2 5 Pin Configuration and Functions 3 6 Specifications 5 6.1 Absolute Maximum Ratings 5 6.2 ESD Ratings..... 5 6.3 Recommended Operating Conditions 5 6.4 Thermal Information 6 6.5 Electrical Characteristics..... 6 6.6 AC Timing Specifications 9 6.7 Typical Characteristics 11 7 Detailed Description 12 7.1 Overview 12	7.2 Functional Block Diagram 12 7.3 Feature Description..... 13 7.4 Device Functional Modes..... 53 7.5 Programming..... 60 7.6 Register Maps 62 8 Application and Implementation 87 8.1 Typical Application 87 9 Device and Documentation Support 88 9.1 Documentation Support 88 9.2 Receiving Notification of Documentation Updates.. 88 9.3 Community Resources..... 88 9.4 Trademarks 88 9.5 Electrostatic Discharge Caution 88 9.6 Glossary 88 10 Mechanical, Packaging, and Orderable Information 88
---	--

4 Revision History

NOTE: Page numbers for previous revisions may differ from page numbers in the current version.

Changes from Revision A (January 2014) to Revision B	Page
• Added <i>Pin Configuration and Functions</i> section, <i>ESD Ratings</i> table, <i>Feature Description</i> section, <i>Device Functional Modes</i> , <i>Application and Implementation</i> section, <i>Power Supply Recommendations</i> section, <i>Layout</i> section, <i>Device and Documentation Support</i> section, and <i>Mechanical, Packaging, and Orderable Information</i> section	1
• Changed the maximum values for the CMOS clock high and low input current parameters in the <i>Electrical Characteristics</i> table	6

Changes from Original (October 2006) to Revision A	Page
• Added content to complete full data sheet.	1
• Deleted the reference to Reflow Temperature Profile specifications from the <i>Absolute Maximum Ratings</i> table	5

5 Pin Configuration and Functions

DGG Package
48-Pin TSSOP
Top View

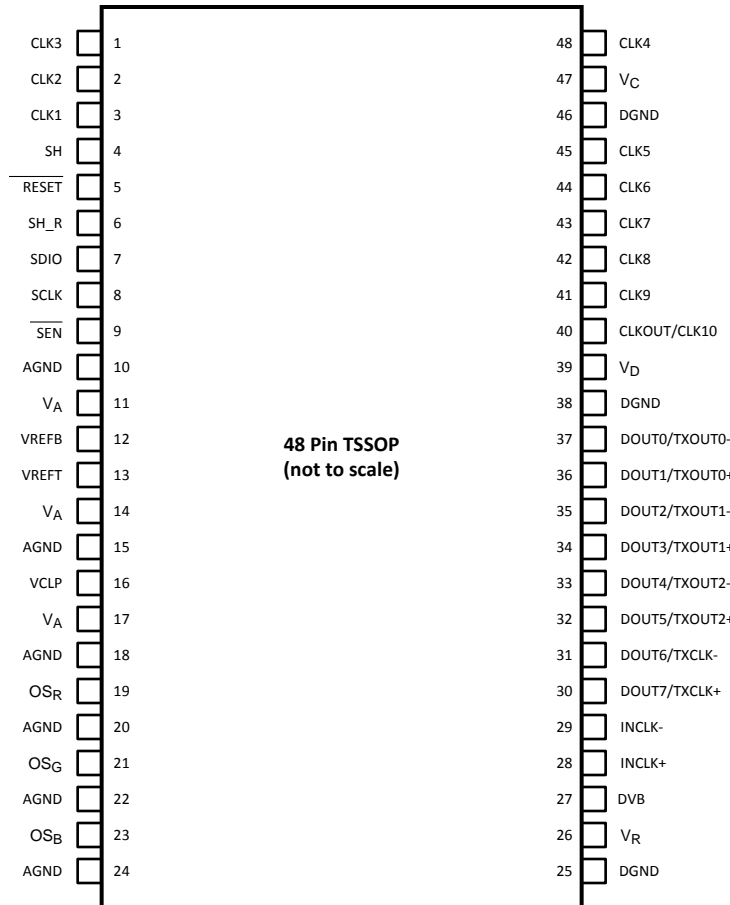

Pin Functions

PIN		I/O ⁽¹⁾	TYPE ⁽¹⁾	RES. ⁽¹⁾	DESCRIPTION
NO.	NAME				
1	CLK3	O	D	PU	Configurable sensor control output.
2	CLK2	O	D	PD	Configurable sensor control output.
3	CLK1	O	D	PU	Configurable sensor control output.
4	SH	O	D	PD	Sensor - Shift or transfer control signal for CCD and CIS sensors.
5	RESET	I	D	PU	Active-low master reset. NC when function not being used.
6	SH_R	I	D	PD	External request for an SH pulse.
7	SDIO	I/O	D		Serial Interface Data Input
8	SCLK	I	D	PD	Serial Interface shift register clock.
9	SEN	I	D	PU	Active-low chip enable for the Serial Interface.
10	AGND	—	P	—	Analog ground return.
11	V _A	—	P	—	Analog power supply. Bypass voltage source with 4.7μF and pin with 0.1μF to AGND.
12	VREFB	O	A	—	Bottom of ADC reference. Bypass with a 0.1μF capacitor to ground.
13	VREFT	O	A	—	Top of ADC reference. Bypass with a 0.1μF capacitor to ground.
14	V _A	—	P	—	Analog power supply. Bypass voltage source with 4.7μF and pin with 0.1μF to AGND.
15	AGND	—	P	—	Analog ground return.

(1) I = Input, O = Output, IO = Bi-directional, P = Power, D = Digital, A = Analog, PU = Pullup with an internal resistor, PD = Pulldown with an internal resistor.

Pin Functions (continued)

PIN		I/O ⁽¹⁾	TYPE ⁽¹⁾	RES. ⁽¹⁾	DESCRIPTION
NO.	NAME				
16	VCLP	IO	A	—	Input Clamp Voltage. Normally bypassed with a 0.1μF, and a 4.7μF capacitor to AGND. An external reference voltage may be applied to this pin.
16	VCLP	IO	A	—	Input Clamp Voltage. Normally bypassed with a 0.1μF, and a 10μF capacitor to AGND. An external reference voltage may be applied to this pin.
17	V _A	—	P	—	Analog power supply. Bypass voltage source with 4.7μF and pin with 0.1μF to AGND.
18	AGND	—	P	—	Analog ground return.
19	OS _R	I	A	—	Analog input signal. Typically sensor Red output AC-coupled through a capacitor.
20	AGND	—	P	—	Analog ground return.
21	OS _G	I	A	—	Analog input signal. Typically sensor Green output AC-coupled through a capacitor.
22	AGND	—	P	—	Analog ground return.
23	OS _B	I	A	—	Analog input signal. Typically sensor Blue output AC-coupled through a capacitor.
24	AGND	—	P	—	Analog ground return.
25	DGND	—	P	—	Digital ground return.
26	V _R	—	P	—	Power supply input for internal voltage reference generator. Bypass this supply pin with a 0.1μF capacitor.
27	DVB	O	D	—	Digital Core Voltage bypass. Not an input. Bypass with 0.1μF capacitor to DGND.
28	INCLK+	I	D	—	Clock Input. Non-Inverting input for LVDS clocks or CMOS clock input. CMOS clock is selected when pin 29 is held at DGND, otherwise clock is configured for LVDS operation.
29	INCLK-	I	D	—	Clock Input. Inverting input for LVDS clocks, connect to DGND for CMOS clock.
30	DOUT7/ TXCLK+	O	D	—	Bit 7 of the digital video output bus in CMOS Mode, LVDS Frame Clock+ in LVDS Mode.
31	DOUT6/ TXCLK-	O	D	—	Bit 6 of the digital video output bus in CMOS Mode, LVDS Frame Clock- in LVDS Mode.
32	DOUT5/ TXOUT2+	O	D	—	Bit 5 of the digital video output bus in CMOS Mode, LVDS Data Out2+ in LVDS Mode.
33	DOUT4/ TXOUT2-	O	D	—	Bit 4 of the digital video output bus in CMOS Mode, LVDS Data Out2- in LVDS Mode.
34	DOUT3/ TXOUT1+	O	D	—	Bit 3 of the digital video output bus in CMOS Mode, LVDS Data Out1+ in LVDS Mode.
35	DOUT2/ TXOUT1-	O	D	—	Bit 2 of the digital video output bus in CMOS Mode, LVDS Data Out1- in LVDS Mode.
36	DOUT1/ TXOUT0+	O	D	—	Bit 1 of the digital video output bus in CMOS Mode, LVDS Data Out0+ in LVDS Mode.
37	DOUT0/ TXOUT0-	O	D	—	Bit 0 of the digital video output bus in CMOS Mode, LVDS Data Out0- in LVDS Mode.
38	DGND	—	P	—	Digital ground return.
39	V _D	—	P	—	Power supply for the digital circuits. Bypass this supply pin with 0.1μF capacitor. A single 4.7μF capacitor should be used between the supply and the VD, VR and VC pins.
40	CLKOUT/ CLK10	O	D	PD	Output clock for registering output data when using CMOS outputs, or configurable sensor control output.
41	CLK9	O	D	PD	Configurable sensor control output.
42	CLK8	O	D	PD	Configurable sensor control output.
43	CLK7	O	D	PD	Configurable sensor control output.
44	CLK6	O	D	PU	Configurable sensor control output.
45	CLK5	O	D	PD	Configurable sensor control output.
46	DGND	—	P	—	Digital ground return.
47	V _C	—	P	—	Power supply for the sensor control outputs. Bypass this supply pin with 0.1μF capacitor.
48	CLK4	O	D	PD	Configurable sensor control output.

6 Specifications

6.1 Absolute Maximum Ratings

See ⁽¹⁾ and ⁽²⁾

	MIN	MAX	UNIT
Supply voltage (V _A , V _R , V _D , V _C)		4.2	V
Voltage on any input pin (not to exceed 4.2 V) ⁽³⁾	-0.3	V _A + 0.3	V
Voltage on any output pin (except DVB and not to exceed 4.2 V)	-0.3	V _A + 0.3	V
DVB output pin voltage		2	V
Input current at any pin other than supply pins ⁽⁴⁾		±25	mA
Package input current (except supply pins) ⁽⁴⁾		±50	mA
Package dissipation at T _A = 25°C ⁽⁵⁾		1.89	W
Maximum junction temperature (T _J)		150	°C
Storage temperature, T _{stg}	-65	150	°C

- Stresses beyond those listed under *Absolute Maximum Ratings* may cause permanent damage to the device. These are stress ratings only, which do not imply functional operation of the device at these or any other conditions beyond those indicated under *Recommended Operating Conditions*. Exposure to absolute-maximum-rated conditions for extended periods may affect device reliability.
- All voltages are measured with respect to AGND = DGND = 0 V, unless otherwise specified.
- The analog inputs are protected as shown below. Input voltage magnitudes beyond the supply rails will not damage the device, provided the current is limited per note 3. However, input errors will be generated if the input goes above V_A and below AGND.

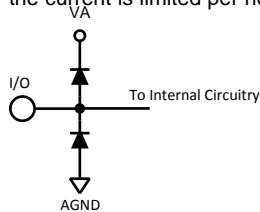

- When the input voltage (V_{IN}) at any pin exceeds the power supplies (V_{IN} < GND or V_{IN} > V_A or V_D), the current at that pin should be limited to 25 mA. The 50 mA maximum package input current rating limits the number of pins that can simultaneously safely exceed the power supplies with an input current of 25 mA to two.
- The maximum power dissipation must be derated at elevated temperatures and is dictated by T_{JMAX}, θ_{JA} and the ambient temperature, T_A. The maximum allowable power dissipation at any temperature is P_D = (T_{JMAX} - T_A)/θ_{JA}. The values for maximum power dissipation listed above will be reached only when the device is operated in a severe fault condition (for example, when input or output pins are driven beyond the power supply voltages, or the power supply polarity is reversed). Such conditions should always be avoided.

6.2 ESD Ratings

		VALUE	UNIT
V _(ESD)	Electrostatic discharge	Human-body model (HBM), per ANSI/ESDA/JEDEC JS-001 ⁽¹⁾	2500
		Machine model (MM)	250

- JEDEC document JEP155 states that 500-V HBM allows safe manufacturing with a standard ESD control process.

6.3 Recommended Operating Conditions

See ⁽¹⁾

	MIN	NOM	MAX	UNIT
All supply voltages	3		3.6	V
Operating temperature	0		70	°C

- All voltages are measured with respect to AGND = DGND = 0 V, unless otherwise specified.

6.4 Thermal Information

THERMAL METRIC ⁽¹⁾		LM98714	
		DGG (TSSOP)	UNIT
		48 PINS	
R _{θJA}	Junction-to-ambient thermal resistance	66	°C/W
R _{θJC(top)}	Junction-to-case (top) thermal resistance	—	°C/W
R _{θJB}	Junction-to-board thermal resistance	—	°C/W
ψ _{JT}	Junction-to-top characterization parameter	—	°C/W
ψ _{JB}	Junction-to-board characterization parameter	—	°C/W
R _{θJC(bot)}	Junction-to-case (bottom) thermal resistance	—	°C/W

(1) For more information about traditional and new thermal metrics, see the [Semiconductor and IC Package Thermal Metrics](#) application report.

6.5 Electrical Characteristics

The following specifications apply for V_A = V_D = V_R = V_C = 3.3 V, C_L = 10 pF, and f_{INCLK} = 15 MHz, T_A = 25°C, unless otherwise specified.

PARAMETER	TEST CONDITIONS	MIN	TYP ⁽¹⁾	MAX	UNIT	
CMOS Digital Input DC Specifications (RESETb, SH_R, SCLK, SENb)						
V _{IH}	Logical 1 input voltage	2			V	
V _{IL}	Logical 0 input voltage			0.8	V	
I _{IH}	Logical 1 input current	RESET, V _{IH} = V _D	235		nA	
		SH_R, SCLK, V _{IH} = V _D	70		μA	
		SEN, V _{IH} = V _D	130		nA	
I _{IL}	Logical 0 input current	RESET, V _{IL} = DGND	70		μA	
		SH_R, SCLK, V _{IL} = DGND	235		nA	
		SEN, V _{IL} = DGND	70		μA	
CMOS Digital Output DC Specifications (SH, CLK1 to CLK10, CMOS Data Outputs)						
V _{OH}	Logical 1 output voltage	I _{OUT} = -0.5 mA	2.95		V	
V _{OL}	Logical 0 output voltage	I _{OUT} = 1.6 mA		0.25	V	
I _{OS}	Output short circuit current	V _{OUT} = DGND	16		mA	
		V _{OUT} = V _D	-20			
I _{OZ}	CMOS output TRI-STATE current	V _{OUT} = DGND	20		nA	
		V _{OUT} = V _D	-25			
CMOS Digital Input/Output DC Specifications (SDIO)						
I _{IH}	Logical 1 input current	V _{IH} = V _D	90		nA	
I _{IL}	Logical 0 input current	V _{IL} = DGND	90		nA	
LVDS/CMOS Clock Receiver DC Specifications (INCLK+ and INCLK- Pins)						
V _{IHL}	Differential LVDS clock high threshold voltage	R _L = 100 Ω, V _{CM} (LVDS Input Common Mode Voltage) = 1.25 V		100	mV	
V _{ILL}	Differential LVDS clock low threshold voltage	R _L = 100 Ω, V _{CM} (LVDS Input Common Mode Voltage) = 1.25 V	-100		mV	
V _{IHC}	CMOS clock high threshold voltage	INCLK- = DGND	2		V	
V _{ILC}	CMOS clock low threshold voltage	INCLK- = DGND		0.8	V	
I _{IHL}	CMOS clock input high current			330	μA	
I _{ILC}	CMOS clock input low current			-160	μA	
LVDS Output DC Specifications						
V _{OD}	Differential output voltage	R _L = 100 Ω	180	328	450	mV

(1) Typical figures are at T_A = 25°C, and represent most likely parametric norms at the time of product characterization. The typical specifications are not ensured.

Electrical Characteristics (continued)

The following specifications apply for $V_A = V_D = V_R = V_C = 3.3\text{ V}$, $C_L = 10\text{ pF}$, and $f_{\text{INCLK}} = 15\text{ MHz}$, $T_A = 25^\circ\text{C}$, unless otherwise specified.

PARAMETER		TEST CONDITIONS	MIN	TYP ⁽¹⁾	MAX	UNIT
V_{OS}	LVDS output offset voltage	$R_L = 100\ \Omega$	1.17	1.23	1.3	V
I_{OS}	Output short circuit current	$V_{\text{OUT}} = 0\text{ V}$, $R_L = 100\ \Omega$		7.9		mA
Power Supply Specifications						
IA	VA analog supply current	VA Normal State	60	97	125	mA
		VA Low Power State (Powerdown)	12	23	32	
IR	VR digital supply current	VR Normal State (LVDS Outputs)	30	64	75	mA
		CMOS Output Data Format	15	47	55	mA
		LVDS Output Data Format with Data Outputs Disabled		47		mA
ID	VD digital output driver supply current	LVDS Output Data Format		0.05		mA
		CMOS Output Data Format (ATE Loading of CMOS Outputs > 50 pF)	12		40	mA
IC	VC CCD timing generator output driver supply current	Typical sensor outputs: SH, CLK1= Φ 1A, CLK2= Φ 2A, CLK3= Φ B, CLK4= Φ C, CLK5=RS, CLK6=CP (ATE Loading of CMOS Outputs > 50 pF)	0.5		12	mA
PWR	Average power dissipation	LVDS Output Data Format	350	505	650	mW
		CMOS Output Data Format (ATE Loading of CMOS Outputs > 50 pF)	380	610	700	mW
Input Sampling Circuit Specifications						
V_{IN}	Input voltage level	CDS Gain=1x, PGA Gain=1x		2.3		Vp-p
		CDS Gain=2x, PGA Gain= 1x		1.22		
$I_{\text{IN_SH}}$	Sample and hold mode input leakage current	Source Followers Off CDS Gain = 1x $OS_X = V_A$ ($OS_X = \text{AGND}$)	50		70	μA
		Source Followers Off CDS Gain = 2x $OS_X = V_A$ ($OS_X = \text{AGND}$)	75		105	μA
		Source Followers On CDS Gain = 2x $OS_X = V_A$ ($OS_X = \text{AGND}$)	-200	-10	200	nA
		Source Followers On CDS Gain = 2x $OS_X = V_A$ ($OS_X = \text{AGND}$)	-200	-16	200	nA
C_{SH}	Sample/hold mode equivalent input capacitance (see Figure 5)	CDS Gain = 1x		2.5		pF
		CDS Gain = 2x		4		
$I_{\text{IN_CDS}}$	CDS mode input leakage current	Source Followers Off $OS_X = V_A$ ($OS_X = \text{AGND}$)	-300	7	300	nA
		Source Followers On $OS_X = V_A$ ($OS_X = \text{AGND}$)	-300	(-25)	300	
R_{CLPIN}	CLPIN switch resistance (OS_X to VCLP Node in Figure 2)			16	50	Ω
VCLP Reference Circuit Specifications						
VCLP DAC resolution				4		Bits
VCLP DAC step size				0.16		V
V_{VCLP}	VCLP DAC voltage minimum output	VCLP Config. Register = 0001 0000b	0.14	0.26	0.43	V
	VCLP DAC voltage maximum output	VCLP Config. Register = 0001 1111b	2.38	2.68	2.93	V
	Resistor ladder enabled	VCLP Config. Register = 0010 xxxxb	1.54	$V_A / 2$	1.73	V
I_{SC}	VCLP DAC short circuit output current	VCLP Config. Register = 0001 xxxxb		30		mA

Electrical Characteristics (continued)

The following specifications apply for $V_A = V_D = V_R = V_C = 3.3\text{ V}$, $C_L = 10\text{ pF}$, and $f_{\text{INCLK}} = 15\text{ MHz}$, $T_A = 25^\circ\text{C}$, unless otherwise specified.

PARAMETER		TEST CONDITIONS	MIN	TYP ⁽¹⁾	MAX	UNIT
Black Level Offset DAC Specifications						
Resolution			10			Bits
Monotonicity			Ensured by characterization			
	Offset Adjustment Range Referred to AFE Input	CDS Gain = 1x Minimum DAC Code = 0x000 Maximum DAC Code = 0x3FF	-614			mV
			614			
	Offset adjustment range referred to AFE output	CDS Gain = 2x Minimum DAC Code = 0x000 Maximum DAC Code = 0x3FF	-307			mV
			307			
DAC LSB step size		CDS Gain = 1x Referred to AFE Output	-16000		-18200	LSB
			16000		18200	
			1.2			mV
			(32)			(LSB)
DNL	Differential nonlinearity		-0.95		3.25	LSB
INL	Integral nonlinearity		-3.1		2.65	LSB
PGA Specifications						
Gain Resolution			8			Bits
Monotonicity			Ensured by characterization			
Maximum gain		CDS Gain = 1x	7.18	7.9	8.77	V/V
			17.1	17.9	18.9	dB
Minimum gain		CDS Gain = 1x	0.56	0.7	0.82	V/V
			-5	-3	-1.72	dB
PGA function		Gain (V/V) = (196/(280-PGA Code))				
		Gain (dB) = 20LOG10(196/(280-PGA Code))				
Channel matching		Minimum PGA Gain	3%			
		Maximum PGA Gain	12.7%			
ADC Specifications						
V_{REFT}	Top of reference		2.07			V
V_{REFB}	Bottom of reference		0.89			V
$V_{\text{REFT}} - V_{\text{REFB}}$	Differential reference voltage		1.07	1.18	1.29	V
Overrange output code			65535			
Underrange output code			0			
Digital Offset DAC Specifications						
Resolution			7			Bits
Digital offset DAC LSB step size		Referred to AFE Output	16			LSB
	Offset adjustment range referred to AFE output	Min DAC Code = 7b0000000	-1024			LSB
		Mid DAC Code = 7b1000000	0			
		Max DAC Code = 7b1111111	1008			
Full Channel Performance Specifications						
DNL	Differential nonlinearity		-0.99	0.8 / -0.6	2.55	LSB
INL	Integral nonlinearity		-73	±23	78	LSB

Electrical Characteristics (continued)

The following specifications apply for $V_A = V_D = V_R = V_C = 3.3\text{ V}$, $C_L = 10\text{ pF}$, and $f_{\text{INCLK}} = 15\text{ MHz}$, $T_A = 25^\circ\text{C}$, unless otherwise specified.

PARAMETER	TEST CONDITIONS	MIN	TYP ⁽¹⁾	MAX	UNIT
Noise floor	Minimum PGA Gain		-79		dB
			7.2		LSB RMS
	PGA Gain = 1x		-74		dB
			13	30	LSB RMS
Maximum PGA Gain		-56		dB	
		104		LSB RMS	
Channel-to-channel crosstalk	Mode 3		47		LSB
	Mode 2		16		

6.6 AC Timing Specifications

The following specifications apply for $V_A = V_D = V_R = V_C = 3.3\text{ V}$, $C_L = 10\text{ pF}$, and $f_{\text{INCLK}} = 15\text{ MHz}$, $T_A = 25^\circ\text{C}$, unless otherwise specified.

		MIN	TYP ⁽¹⁾	MAX	UNIT	
Input Clock Timing Specifications						
f_{INCLK}	Input Clock Frequency	Mode 3, INCLK = PIXCLK (Pixel Rate Clock)		15	MHz	
		Mode 2, INCLK = PIXCLK (Pixel Rate Clock)		22.5		
		Mode 1, INCLK = PIXCLK (Pixel Rate Clock)		30		
		Mode 3, INCLK = ADCCLK (ADC Rate Clock)	5		45	MHz
		Mode 2, INCLK = ADCCLK (ADC Rate Clock)	5		45	
		Mode 1, INCLK = ADCCLK (ADC Rate Clock)	5		30	
T_{dc}	Input Clock Duty Cycle	40/60%	50/50%	60/40%		
Full Channel Latency Specifications						
t_{SHFP}	SH out to first sampled pixel	PIXPHASE0		3	T_{ADC}	
	Figure 11 (Mode 3)	PIXPHASE1		3 3/7		
	Figure 12 (Mode 2)	PIXPHASE2		4		
	Figure 13 (Mode 1)	PIXPHASE3		4 3/7		
t_{LAT3}	3 channel mode pipeline delay Figure 45 (LVDS) Figure 50 (CMOS)	PIXPHASE0		19	T_{ADC}	
		PIXPHASE1		18 4/7		
		PIXPHASE2		18		
		PIXPHASE3		17 4/7		
t_{LAT2}	2 channel mode pipeline delay Figure 46 (LVDS) Figure 51 (CMOS)	PIXPHASE0		18	T_{ADC}	
		PIXPHASE1		17 4/7		
		PIXPHASE2		17		
		PIXPHASE3		16 4/7		
t_{LAT1}	1 channel mode pipeline delay Figure 47 (LVDS) Figure 52 (CMOS)	PIXPHASE0		16	T_{ADC}	
		PIXPHASE1		15 4/7		
		PIXPHASE2		15		
		PIXPHASE3		14 4/7		

(1) Typical figures are at $T_A = 25^\circ\text{C}$, and represent most likely parametric norms at the time of product characterization. The typical specifications are not ensured.

AC Timing Specifications (continued)

The following specifications apply for $V_A = V_D = V_R = V_C = 3.3\text{ V}$, $C_L = 10\text{ pF}$, and $f_{\text{INCLK}} = 15\text{ MHz}$, $T_A = 25^\circ\text{C}$, unless otherwise specified.

		MIN	TYP ⁽¹⁾	MAX	UNIT
t_{SHFD}	SH out to first valid data ($t_{\text{SHFP}} + t_{\text{LATx}}$)	Mode 3	22		T_{ADC}
		Mode 2	21		
		Mode 1	19		
SH_R Timing Specifications (Figure 41)					
t_{SHR_S}	SH_R setup time	1.28			ns
t_{SHR_H}	SH_R hold time	2.25			ns
LVDS Output Timing Specifications (Figure 44)					
TX_{valid}	TX output data valid window	$f_{\text{INCLK}} = 45\text{ MHz}$ INCLK = ADCCLK (ADC Rate Clock)	2		ns
TX_{pp0}	TXCLK to pulse position 0	LVDS Output Specifications not tested in production. Min/Max ensured by design, characterization and statistical analysis.	0.013		ns
TX_{pp1}	TXCLK to pulse position 1		3.093		ns
TX_{pp2}	TXCLK to pulse position 2		6.238		ns
TX_{pp3}	TXCLK to pulse position 3		9.613		ns
TX_{pp4}	TXCLK to pulse position 4		12.663		ns
TX_{pp5}	TXCLK to pulse position 5		15.762		ns
TX_{pp6}	TXCLK to pulse position 6		18.982		ns
CMOS Output Timing Specifications					
t_{CRDO}	CLKOUT rising edge to CMOS output data	$f_{\text{INCLK}} = 45\text{ MHz}$, INCLK = ADCCLK, (ADC Rate Clock)	-2.83	2.7	ns
t_{CFDO}	CLKOUT Falling edge to CMOS output data	$f_{\text{INCLK}} = 45\text{ MHz}$, INCLK = ADCCLK, (ADC Rate Clock)	-2.83	2.7	ns
Serial Interface Timing Specifications					
f_{SCLK}	Input clock frequency	$f_{\text{SCLK}} \leq f_{\text{INCLK}}$ INCLK = PIXCLK (Pixel Rate Clock) Mode 3/2/1		15/22.5/30	MHz
		$f_{\text{SCLK}} \leq f_{\text{INCLK}}$ INCLK = ADCCLK (ADC Rate Clock) Mode 3/2/1		45/45/30	MHz
	SCLK duty cycle		50/50		ns
t_{IH}	Input hold time		1		ns
t_{IS}	Input setup time		4		ns
t_{SENSC}	SCLK start time after $\overline{\text{SEN}}$ low		1.25		ns
t_{SCSEN}	$\overline{\text{SEN}}$ high after last SCLK rising edge		2.82		ns
t_{SENW}	$\overline{\text{SEN}}$ pulse width	INCLK must be active during serial interface commands.	4		T_{INCLK}
t_{OD}	Output delay time		11	14.6	ns
t_{HZ}	Data output to High Z			0.5	T_{SCLK}

6.7 Typical Characteristics

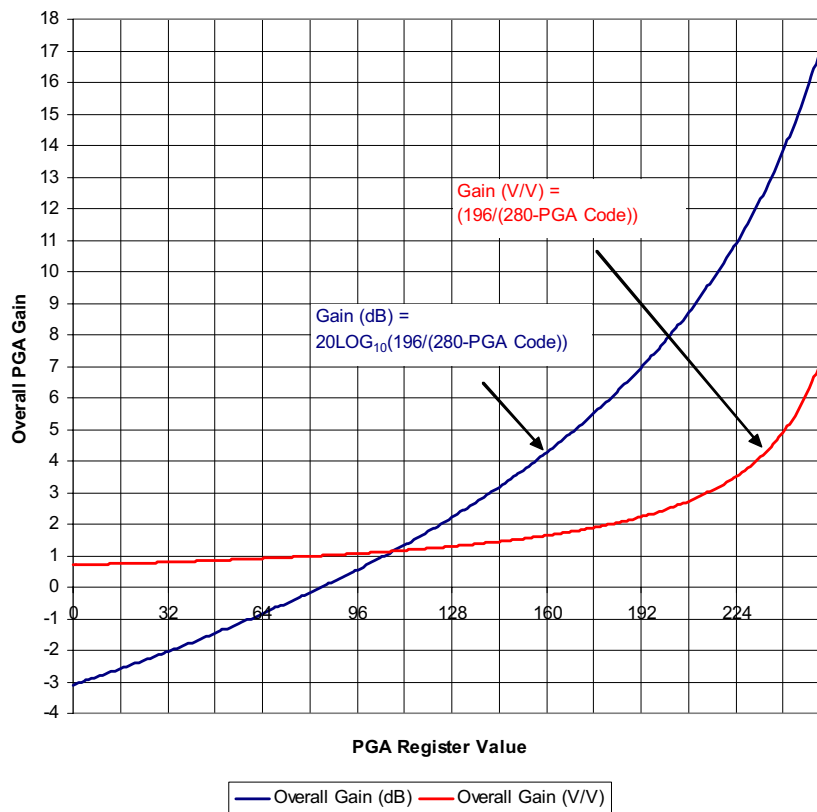

Figure 1. PGA Gain vs. PGA Gain Code

7 Detailed Description

7.1 Overview

The LM98714 is a 16-bit, three-input, complete Analog Front End (AFE) for digital color copier and Multi-Function Peripheral (MFP) applications. The system block diagram of the LM98714, shown in [Functional Block Diagram](#) highlights the main features of the device. Each input has its own Input Bias and Clamping Network which are routed through a selectable Sample/Hold (S/H) or Correlated Double Sampler (CDS) amplifier. A ± 9 -Bit Offset DAC applies independent offset correction for each channel. A -3 to 17.9 dB Programmable Gain Amplifier (PGA) applies independent gain correction for each channel. The LM98714 also provides independent Digital Black Level Correction Feedback Loops for each channel. The Black Level Correction Loop can be configured to run in Manual Mode (where the user inputs their own values of DAC offset) or in Automatic Mode where the LM98714 calculates each channel's Offset DAC value during optical black pixels and then adjusts the Offset register accordingly. The signals are routed to a single high performance 16-bit, 45 MHz analog-to-digital converter.

7.2 Functional Block Diagram

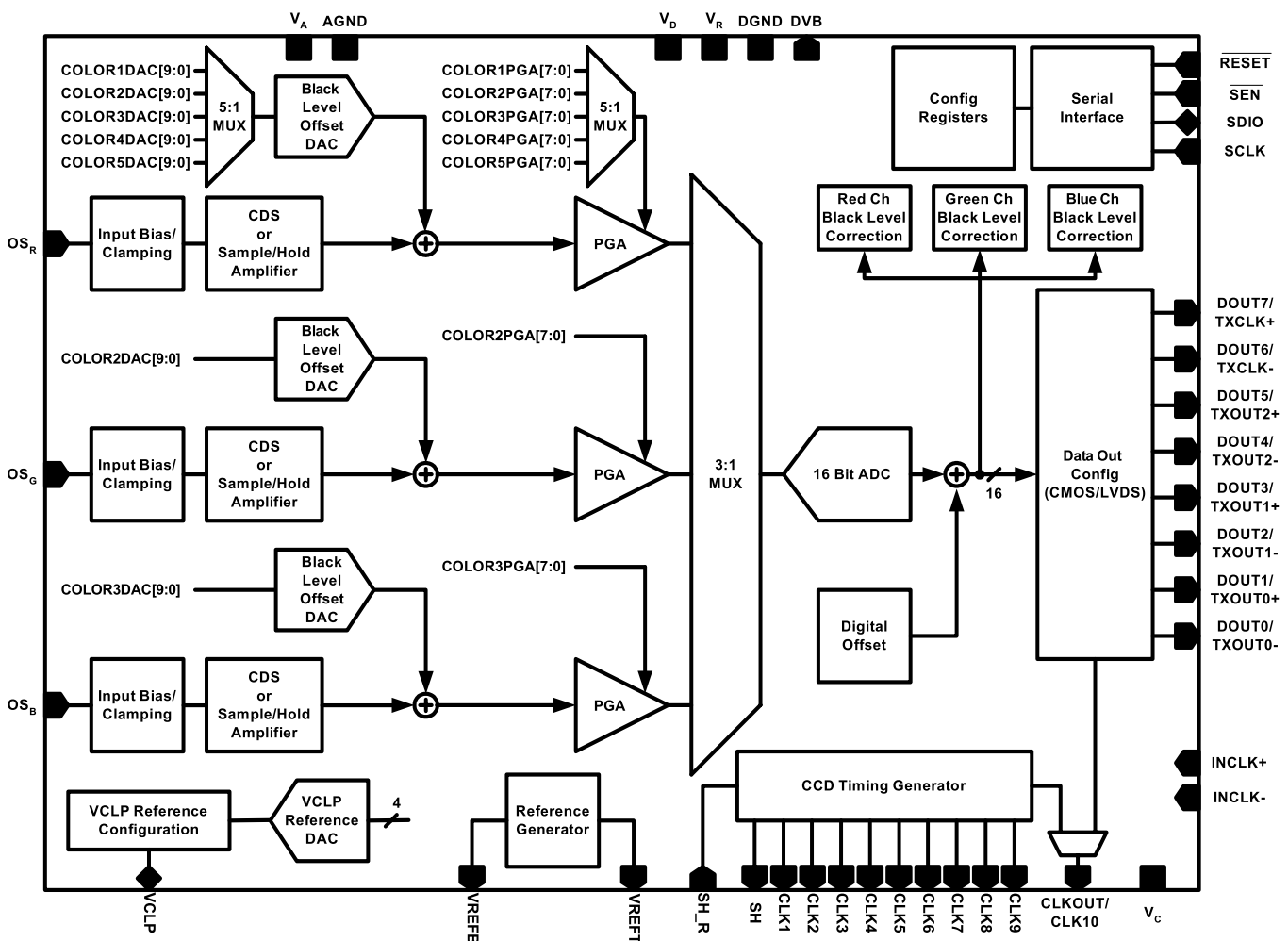

7.3 Feature Description

7.3.1 Input Clock Introduction

The clock input to the LM98714 can be a differential LVDS clock on the INCLK+ and INCLK- pins or a CMOS level clock applied to the INCLK+ pin with the INCLK- pin connected to DGND. The external clock signal format is auto sensed internally. In addition to the two available level formats, the input clock can be applied at the Pixel frequency (PIXCLK) or at the ADC frequency (ADCCLK). The LM98714 can perform internal clock multiplication when a Pixel frequency clock is applied, or no multiplication when an ADC frequency clock is applied. The internal configuration registers need to be written to perform the proper setup of the input clock. [Table 1](#) shows the available input clock configurations for each operating mode.

Table 1. Input Clock Configurations

AFE Mode	Input Clock Type	Internal Multiplier	INCLK Max Freq.	Configuration Register Settings
Mode 3	INCLK = Pixel Freq. (PIXCLK)	3x	15 MHz	PIXCLK Configuration: Main Config Reg 1, Bit[2] = 1'b1
	INCLK = ADC Freq. (ADCCLK)	1x	45 MHz	ADCCLK Configuration: Main Config Reg 1, Bit[2] = 1'b0
Mode 2	INCLK = Pixel Freq. (PIXCLK)	2x	22.5 MHz	PIXCLK Configuration: Main Config Reg 1, Bit[2] = 1'b1
	INCLK = ADC Freq. (ADCCLK)	1x	45 MHz	ADCCLK Configuration: Main Config Reg 1, Bit[2] = 1'b0
Mode 1	INCLK = Pixel Freq. = ADC Freq. (ADCCLK = PIXCLK in Mode 1)	1x	30MHz	Main Config Reg 1, Bit[2] = 1'bx

7.3.2 Modes of Operation

The LM98714 can be configured to operate in several different operating modes. The following sections are a brief introduction to these modes of operation. A more rigorous explanation of the operating modes is contained in the [Modes of Operation](#) section, including input sampling diagrams for each mode as well as a description of the operating conditions.

7.3.2.1 Mode 3 - Three Channel Input/Synchronous Pixel Sampling

OS_B, OS_G, and OS_R inputs are sampled synchronously at a pixel rate. The sampled signals are processed with each channel's offset and gain adjusted independently via the control registers. The order in which pixels are processed from the input to the ADC is fully programmable and is synchronized by the SH pulse. In this mode, the maximum channel speed is 15MSPS per channel with the ADC running at 45MSPS yielding a three color throughput of 45MSPS.

7.3.2.2 Mode 2 - Two Channel Input/Synchronous Pixel Sampling

Mode 2 is useful for CCD sensors with a Black and White mode with Even and Odd outputs. In its default configuration, Mode 2 samples the Even output via the OS_B channel input, and the Odd output via the OS_G channel input. Sampling of the Even and Odd pixels is performed synchronously at a maximum sample rate of 22.5MSPS per input with the ADC running at 45MSPS.

7.3.2.3 Mode 1a - One Channel Input/One, Two, Three, Four, or Five Color Sequential Line Sampling

In Mode 1a, all pixels are processed through a single input (OS_R, OS_G, or OS_B) chosen through the control register setup. This mode is useful in applications where only one input channel is used. The selected input is programmable through the control register. If more than one color is being sent to the input, the user can configure the OS_R channel to utilize up to five offset and gain coefficients for up to five different lines of color pixels. The SH pulse at the beginning of each line sequences the DAC and PGA coefficients as configured in the control registers. In this mode, the maximum channel speed is 30MSPS per channel with the ADC running at 30MSPS.

7.3.2.4 Mode 1b - One Channel Input Per Line/Sequential Line (Input) Sampling/Three Channel Processing

In Mode 1b the OS_R, OS_G, and OS_B inputs are sampled one input per line with the input selection being sequenced to the next color by an SH pulse. This mode is useful with sensors that output whole lines of pixels of a single color. The order in which the inputs are sampled is fully programmable. Sequencing from one channel to the next is triggered by the SH pulse. The first SH pulse after this mode is set (or reset) sets up the first programmed input for gain and offset and initiates sampling through that input alone. The next SH pulse switches the active input to the second channel indicated by the configuration registers. This sequencing with SH pulses continues to the third input and then continuously loops through the inputs. In this mode, the maximum channel speed is 30MSPS per channel with the ADC running at 30MSPS.

7.3.3 Input Bias and Clamping

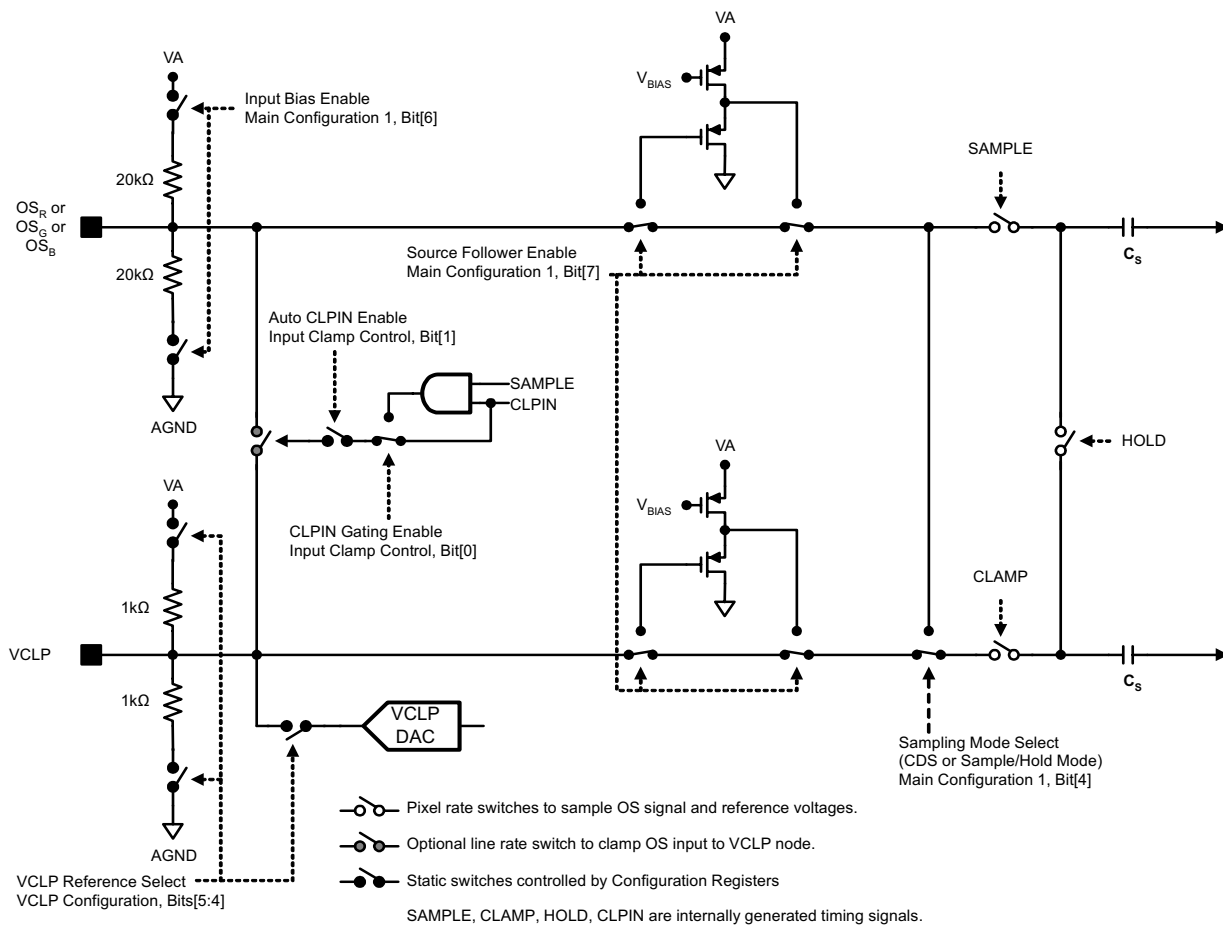

Figure 2. Input Bias and Clamping Diagram

The inputs to the LM98714 are typically AC coupled through a film capacitor and can be sampled in either Sample and Hold Mode (S/H Mode) or Correlated Double Sampling Mode (CDS Mode). In either mode, the DC bias point for the LM98714 side of the AC coupling capacitor is set using the circuit of Figure 2 which can be configured to operate in a variety of different modes.

A typical CCD waveform is shown in Figure 3. Also shown in Figure 3 is an internal signal “SAMPLE” which can be used to “gate” the CLPIN signal so that it only occurs during the “signal” portion of the CCD pixel waveform.

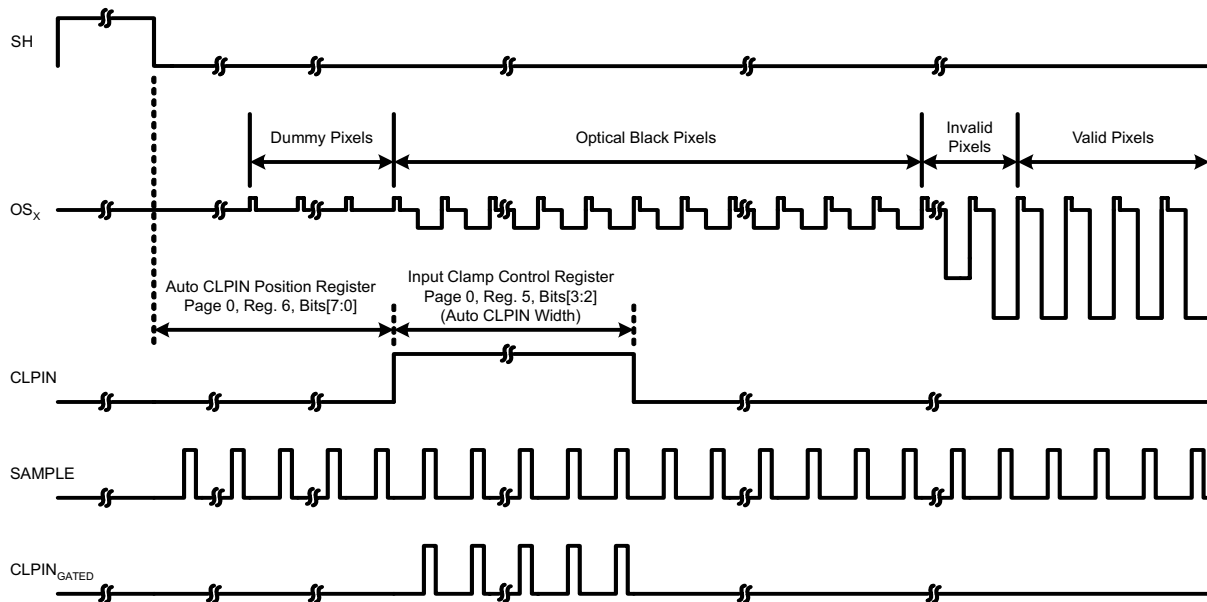

Figure 3. Typical CCD Waveform and LM98714 Input Clamp Signal (CLPIN)

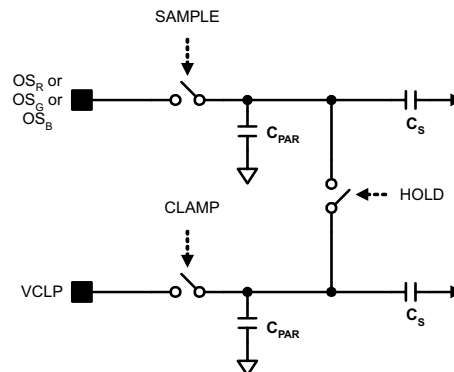

Figure 4. Sample and Hold Mode Simplified Input Diagram

Proper DC biasing of the CCD waveform in Sample and Hold mode is critical for realizing optimal operating conditions. In Sample/Hold mode, the Signal Level of the CCD waveform is compared to the DC voltage on the VCLP pin. In order to fully utilize the range of the input circuitry, it is desirable to cause the Black Level signal voltage to be as close to the VCLP voltage as possible, resulting in a near zero scale output for Black Level pixels.

In Sample/Hold Mode, the DC bias point of the input pin is typically set by actuating the input clamp switch (see Figure 2) during optical black pixels which connects the input pins to the VCLP pin DC voltage. The signal controlling this switch is an auto-generated pulse, CLPIN. CLPIN is generated with a programmable pixel delay with respect to SH and a programmable pixel width. These parameters are available through the serial interface control registers.

Actuating the input clamp will force the average value of the CCD waveform to be centered around the VCLP DC voltage. During Optical Black Pixels, the CCD output has roughly three components. The first component of the pixel is a “Reset Noise” peak followed by the Reset (or Pedestal) Level voltage, then finally the Black Level voltage signal. Taking the average of these signal components will result in a final “clamped” DC bias point that is close to the Black Level signal voltage.

To provide a more precise DC bias point (i.e. a voltage closer to the Black Level voltage), the CLPIN pulse can be “gated” by the internally generated SAMPLE clock. This resulting $CLPIN_{GATED}$ signal is the logical “AND” of the SAMPLE and CLPIN signals as shown in Figure 3. By using the $CLPIN_{GATED}$ signal, the higher Reset Noise peak will not be included in the clamping period and only the average of the Reset Level and Black Level components of the CCD waveform will be centered around VCLP.

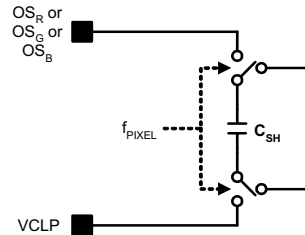

Figure 5. Equivalent Input Switched Capacitance S/H Mode

In Sample and Hold Mode, the impedance of the analog input pins is dominated by the switched capacitance of the CDS/Sample and Hold amplifier. The amplifier switched capacitance, shown as C_S in Figure 4, and internal parasitic capacitances can be estimated by a single capacitor switched between the analog input and the VCLP reference pin for Sample and Hold mode. During each pixel cycle, the modeled capacitor, C_{SH} , is charged to the OS_X -VCLP voltage then discharged. The average input current at the OS_X pin can be calculated knowing the input signal amplitude and the frequency of the pixel. If the application requires AC coupling of the CCD output to the LM98714 analog inputs, the Sample and Hold Mode input bias current may degrade the DC bias point of the coupling capacitor. To overcome this, Input Source Follower Buffers are available to isolate the larger Sample and Hold Mode input bias currents from the analog input pin (as discussed in the following section). As shown in Figure 6, the input bias current is much lower for CDS mode, eliminating the need for the source follower buffers.

7.3.3.1 CDS Mode

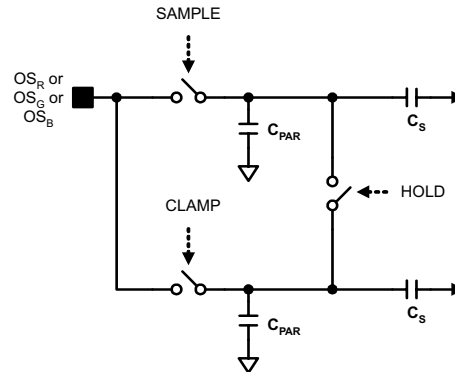

Figure 6. CDS Mode Simplified Input Diagram

Correlated Double Sampling mode does not require as precise a DC bias point as does Sample and Hold mode. This is due mainly to the nature of CDS itself, that is, the Video Signal voltage is referenced to the Reset Level voltage instead of the static DC VCLP voltage. The common mode voltage of these two points on the CCD waveform have little bearing on the resulting differential result. However, the DC bias point does need to be established to ensure the CCD waveform’s common mode voltage is within rated operating ranges.

The CDS mode biasing can be performed in the same way as described in the Sample/Hold Mode Biasing section, or, an alternative method is available which precludes the need for a CLPIN pulse. Internal resistor dividers can be switched in across the OS_R , OS_G , and/or OS_B inputs to provide the DC bias voltage.

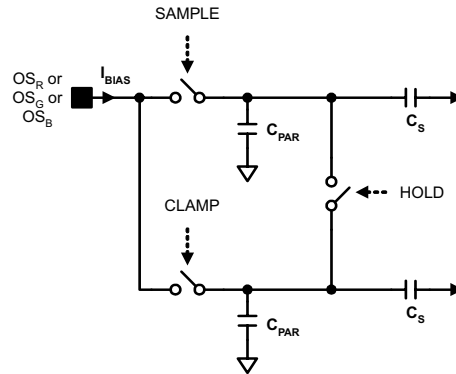

Figure 7. CDS Mode Input Bias Current

Unlike in Sample and Hold Mode, the input bias current in CDS Mode is relatively small. Due to the architecture of CDS switching, the average charge loss or gain on the input node is ideally zero over the duration of a pixel. This results in a much lower input bias current, whose main source is parasitic impedances and leakage currents. As a result of the lower input bias current in CDS Mode, maintaining the DC Bias point the input node over the length of a line will require a much smaller AC input coupling capacitor.

7.3.3.2 Input Source Follower Buffers

The OS_R , OS_G , OS_B inputs each have an optional Source Follower Buffer which can be selected with Main Configuration Register 1, Bit[7]. These source followers provide a much higher impedance seen at the inputs. In some configurations, such as Sample and Hold Mode with AC coupled inputs, the DC bias point of the input nodes must remain as constant as possible over the entire length of the line to ensure a uniform comparison to reference level (VCLP in this case). The Source Followers effectively isolate the AC input coupling capacitor from the switched capacitor network internal to the LM98714's Sample and Hold/CDS Amplifier. This results in a greatly reduced charge loss or gain on the AC Input coupling capacitor over the length of a line, thereby preserving its DC bias point.

The Source Followers should only be used in the 1.2 V input range (i.e. Main Configuration Register 2, Bit[4] = 1, CDS Gain = 2x). Using the Source Followers in the 2.4 V (i.e. Main Configuration Register 2, Bit[4] = 0, CDS Gain = 1x) input range will result in a loss of performance (mainly linearity performance at the high and low ends of the input range).

7.3.3.3 VCLP DAC

The VCLP pin provides the reference level for incoming signals in Sample and Hold Mode. The pin's voltage can be set by one of three sources by writing to the VCLP Configuration Register on register page 0. By default, the VCLP pin voltage is established by an internal resistor divider which sets the voltage to $V_A/2$. The resistor ladder can be disconnected and the pin driven externally by the application.

The most flexible method of setting the VCLP voltage is using the internal VCLP DAC buffer. The DAC is connected by setting the VCLP Configuration register Bit[5:4] to 2b'01. The DAC has a four bit "offset binary" format which is summarized in Table 2. The DAC output has an approximate swing of ± 1.2 V.

Table 2. VCLP DAC Format

VCLP Configuration [3:0]	Typical VCLP Output
0	-Full Scale
0111	Mid Scale - LSB
1000	Mid Scale
1001	Mid Scale + 1 LSB
1111	+Full Scale

7.3.4 Coarse Pixel Phase Alignment

Precise placement of the CCD video signal sampling point is a critical aspect in any typical imaging application. Many factors such as logic gate propagation delays and signal skew increase the difficulty in properly aligning the CCD pixel output signals with the AFE input sampling points. The LM98714 provides two powerful features to aid the system level designer in properly sampling the CCD video signal under a large range of conditions. The first feature, discussed in this section, is the Coarse Pixel Phase Alignment block. As the name implies, this block provides a very coarse range of timing adjustment to align the phase of the CCD Pixel output with the phase of the LM98714 sample circuit. The second feature, discussed on the [Internal Sample Timing](#) section, is the block which is designed for fine tuning of the sampling points within the selected Coarse Pixel Alignment Phase. A small portion of a typical imaging application is shown in [Figure 8](#).

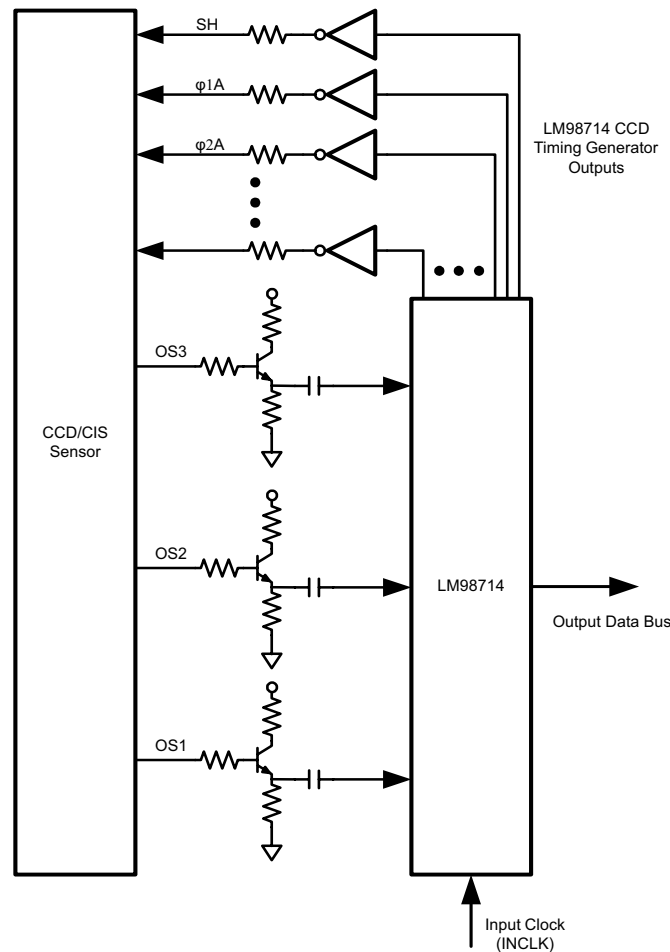
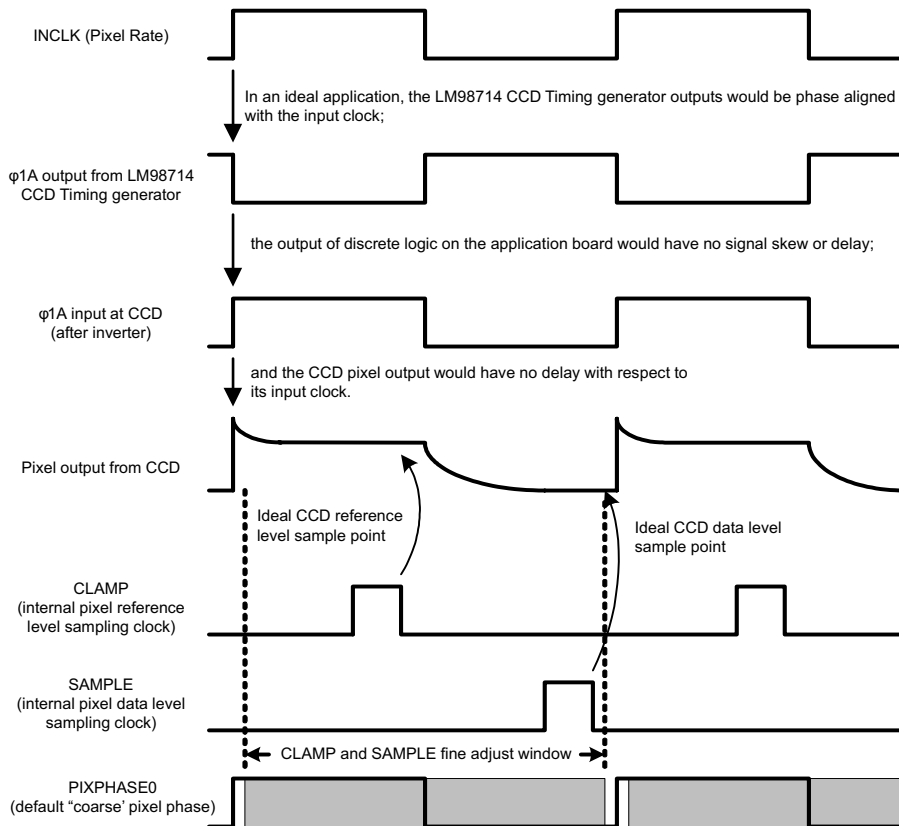

Figure 8. Typical AFE/CCD Interface

As shown in the diagram, the LM98714 provides the timing signals to drive the CCD using external logic gates to drive the high capacitance CCD clock pins. The pixels are shifted out of the CCD, through the emitter follower buffers and received by the LM98714 inputs for processing.

In an ideal application, depicted in Figure 9, the Pixel output signal would be in phase with the timing signals that drove the CCD. The LM98714 input sampling clocks (CLAMP and SAMPLE) are adjustable within a pixel period. By default, the pixel period (or pixel “phase”) is defined to be in line with the input clock. As shown in the ideal case in Figure 9, CLAMP and SAMPLE can be properly adjusted to their ideal positions within the pixel phase, shown below at the stable region near the end of the pedestal and data phases.



By default, the LM98714's internal sampling clocks (CLAMP and SAMPLE) are adjustable within PIXPHASE0, an internal pixel rate clock which is in phase with the input clock.

Figure 9. Clock Alignment in an Ideal Application

In a real system however, propagation delays exist in all stages of the signal chain. These propagation delays will lead to a shift in the CCD Pixel outputs with respect to the LM98714 input clock. The phase shift of the CCD Pixel output, demonstrated in [Figure 10](#), can lead to significant sample timing issues if not properly corrected.

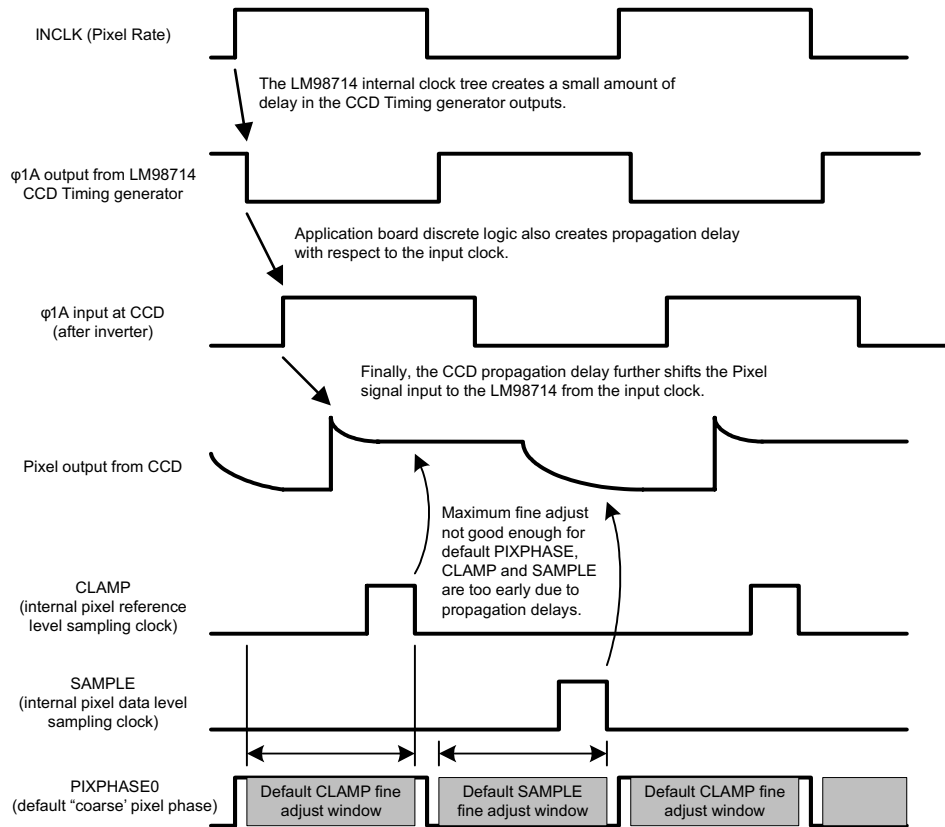
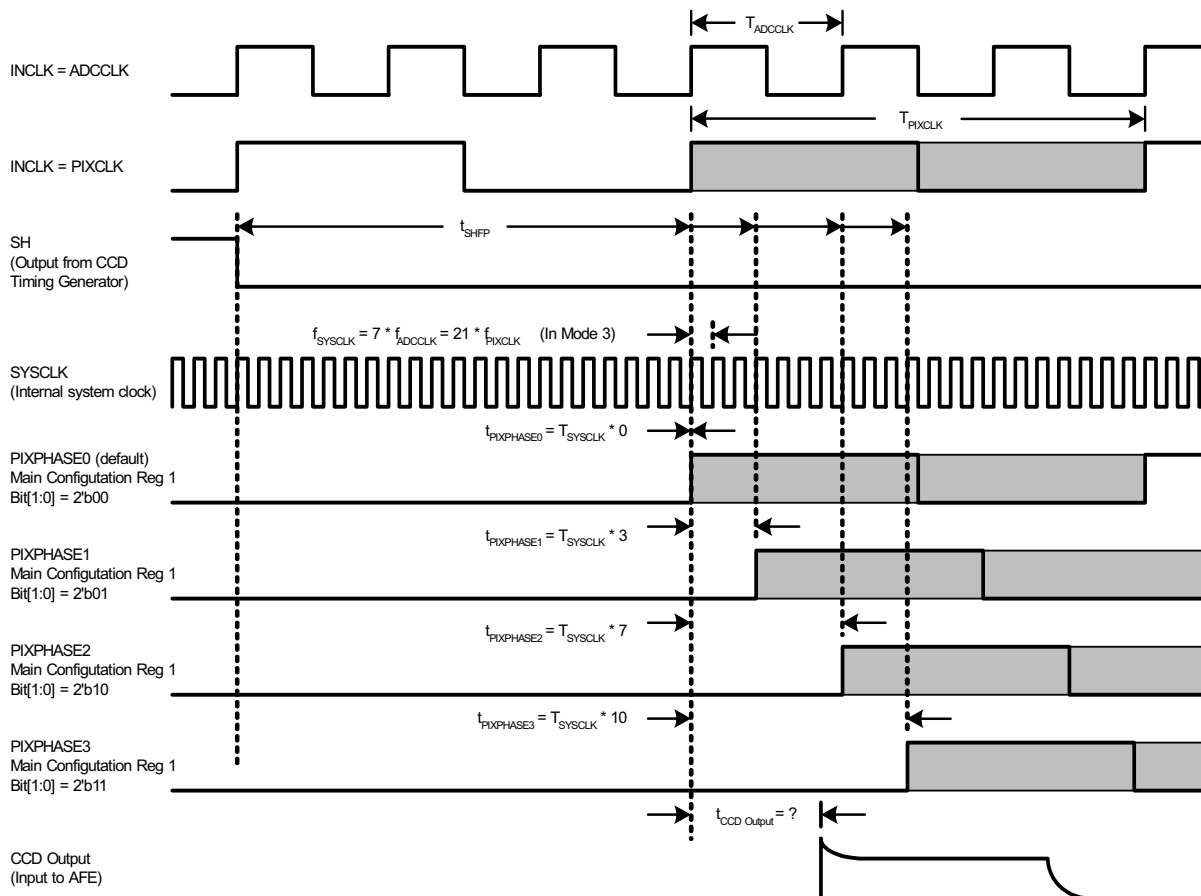

Figure 10. CCD Output Phase Shift in a Real Application

In the default mode, the LM98714 sampling is performed during a clock period whose phase is aligned with the input clock (ignoring any clock tree skew for the moment). The actual sampling clocks are adjustable within the clock period, as shown in [Figure 10](#) (shown for CDS mode in the diagram) and further described in the [Internal Sample Timing](#) section. As shown in the diagram, the delay of the CCD Pixel output is shifted far enough that the fine CLAMP and SAMPLE clocks cannot be placed in a stable portion of the waveform. To remedy this situation, the LM98714's Coarse Pixel Phase Alignment feature allows the designer to shift the entire phase of the analog front end with respect to the input clock. This allows the designer to choose one of four sampling phases which best matches the delay in the external circuitry. Once the "Coarse Pixel Phase" has been chosen, the designer can then fine tune the sampling clocks using the fine adjustment (see [Internal Sample Timing](#)).

The four available Coarse Pixel Phases (PIXPHASE0 - PIXPHASE3) are depicted in Figure 11 (Mode 3), Figure 12 (Mode 2) and Figure 13 (Mode 1). Also shown in the diagrams are the external input clock (INCLK) and a typical CCD output delayed from the input clock.



The CCD output will usually have a measurable delay with respect to the input clock to the AFE. The AFE's internal sampling clocks are based on one of four PIXPHASE clocks. These PIXPHASE settings provide coarse adjustment of the internal AFE clock domain to best match the phase of the incoming CCD signal. Fine adjustment of the sampling clocks is discussed in another section. In this example above, PIXPHASE2 appears to provide the closest match for the incoming CCD signal.

Figure 11. Mode 3 Coarse Pixel Adjustment

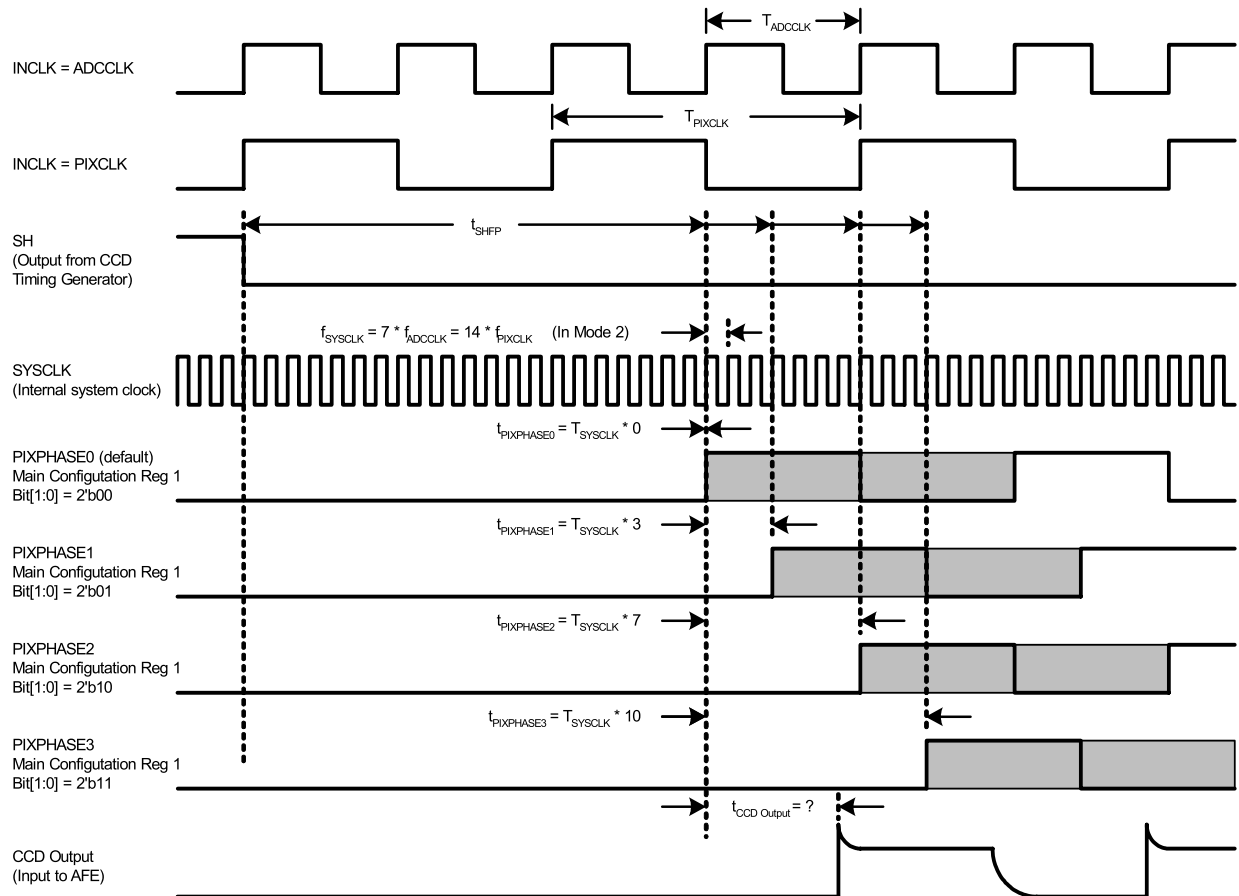

The CCD output will usually have a measurable delay with respect to the input clock to the AFE. The AFE's internal sampling clocks are based on one of four PIXPHASE clocks. These PIXPHASE settings provide coarse adjustment of the internal AFE clock domain to best match the phase of the incoming CCD signal. Fine adjustment of the sampling clocks is discussed in another section. In this example above, PIXPHASE2 appears to provide the closest match for the incoming CCD signal.

Figure 12. Mode 2 Coarse Pixel Phase Adjustment

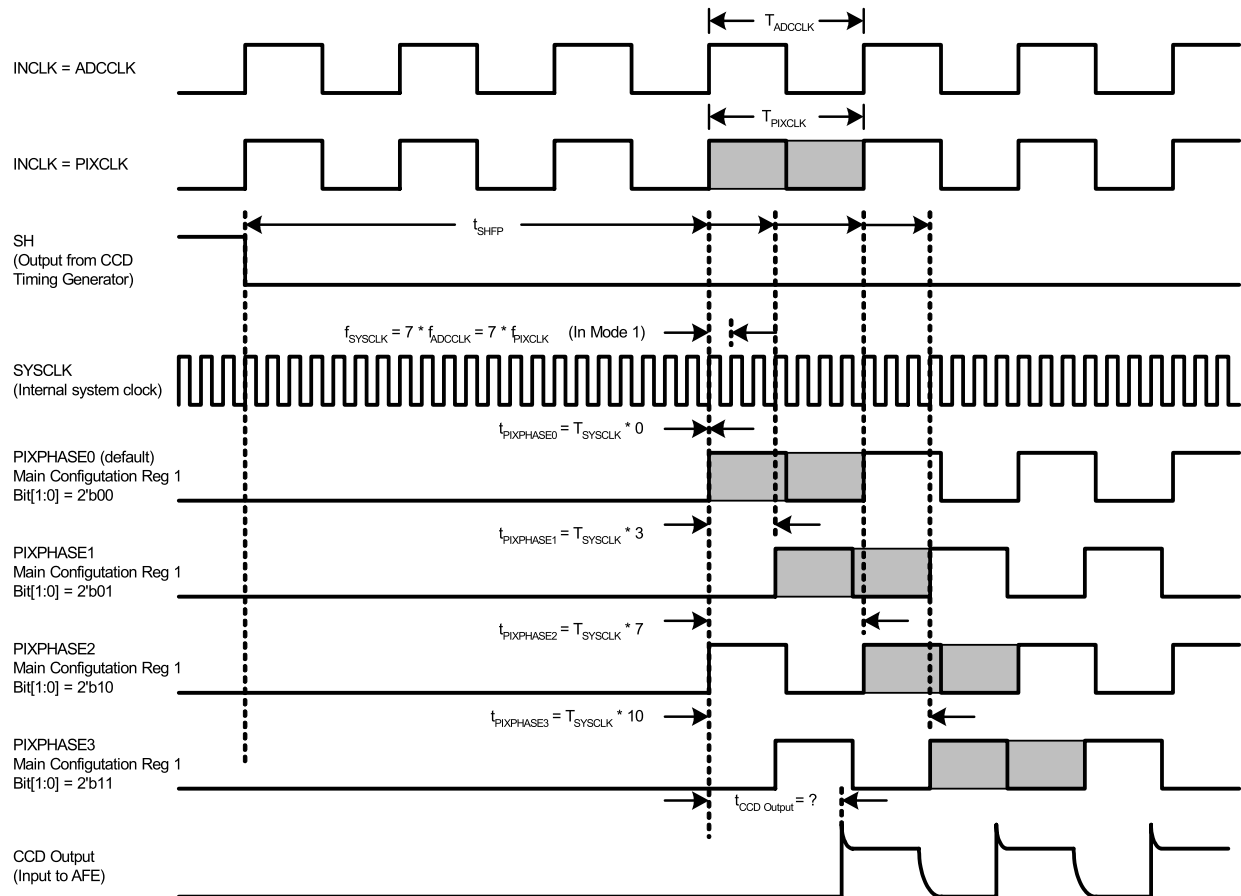

The CCD output will usually have a measurable delay with respect to the input clock to the AFE. The AFE's internal sampling clocks are based on one of four PIXPHASE clocks. These PIXPHASE settings provide coarse adjustment of the internal AFE clock domain to best match the phase of the incoming CCD signal. Fine adjustment of the sampling clocks is discussed in another section. In this example above, PIXPHASE2 appears to provide the closest match for the incoming CCD signal.

Figure 13. Mode 1 Coarse Pixel Phase Adjustment

7.3.5 Internal Sample Timing

A typical CCD input signal is depicted in [Figure 14](#) and [Figure 15](#). Also shown are the internally generated SAMPLE and CLAMP pulses. These signals provide the sampling points of the input signal (OS_X). The timing of SAMPLE and CLAMP is derived from an internal system clock (SYSCLK).

The pixel's reference level input (depicted as V_{REF}) is captured by the falling edge of the CLAMP pulse. In Sample/Hold Mode the V_{REF} input is a sample of the VCLP DC voltage. In CDS Mode the CLAMP pulse samples the pedestal Level of the CCD output waveform.

The pixel's signal level input (depicted as V_{SIG}) is captured by the SAMPLE pulse. In either Sample/Hold or CDS Mode, the V_{SIG} input is the signal level of the CCD output waveform.

The LM98714 provides fine adjustment of the CLAMP and SAMPLE pulse placement within the pixel period. This allows the user to program the optimum location of the CLAMP and SAMPLE falling edges. In CDS mode, both CLAMP and SAMPLE are independently adjustable for each channel in use. In Sample/Hold mode, CLAMP is coincident with SAMPLE by default, but is also independently adjustable. The available fine tuning locations for CLAMP and SAMPLE are shown in [Figure 16](#) through [Figure 21](#) for each sampling mode (CDS or S/H) and channel mode (3, 2, or 1 Channel).

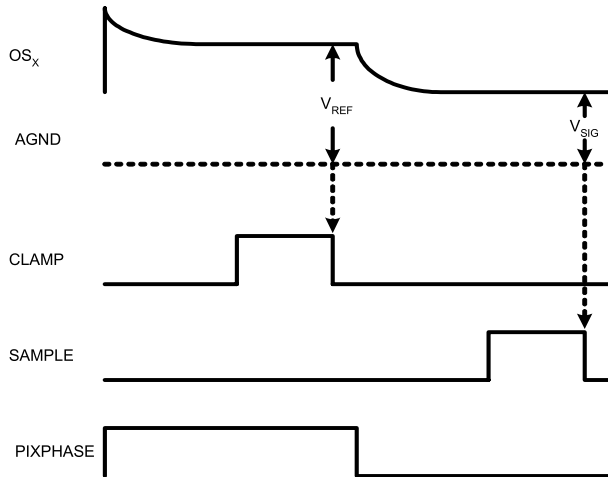

CLAMP and SAMPLE are the internal sampling clocks for the input CDS amplifier. CLAMP and SAMPLE are adjustable within the selected PIXPHASE setting.

In CDS mode, CLAMP falling edge captures the pixel reference level (V_{REF}).
 In CDS mode, SAMPLE falling edge captures the pixel signal level (V_{SIG}).

PIXPHASE is 1 of 4 internal reference clocks used to estimate the phase of the incoming pixel. Once the coarse estimation of the pixel location is chosen via PIXPHASE, the CLAMP and SAMPLE clocks can be fine tuned within PIXPHASE to their optimum location.

Figure 14. Pixel Sampling in CDS Mode

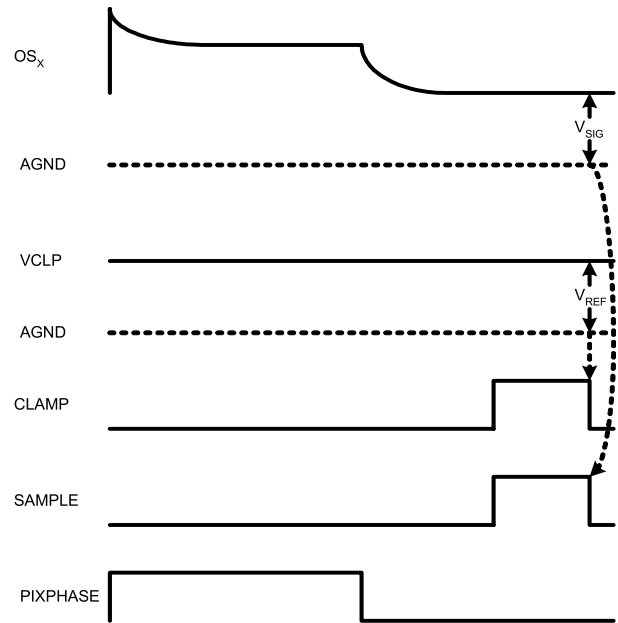

CLAMP and SAMPLE are the internal sampling clocks for the input CDS amplifier. CLAMP and SAMPLE are adjustable within the selected PIXPHASE setting.

In S/H mode, CLAMP falling edge captures the VCLP pin voltage as the pixel reference voltage (V_{REF}).
 In S/H mode, SAMPLE falling edge captures the pixel signal level (V_{SIG}).

PIXPHASE is 1 of 4 internal reference clocks used to estimate the phase of the incoming pixel. Once the coarse estimation of the pixel location is chosen via PIXPHASE, the CLAMP and SAMPLE clocks can be fine tuned within PIXPHASE to their optimum location.

Figure 15. Pixel Sampling in S/H Mode

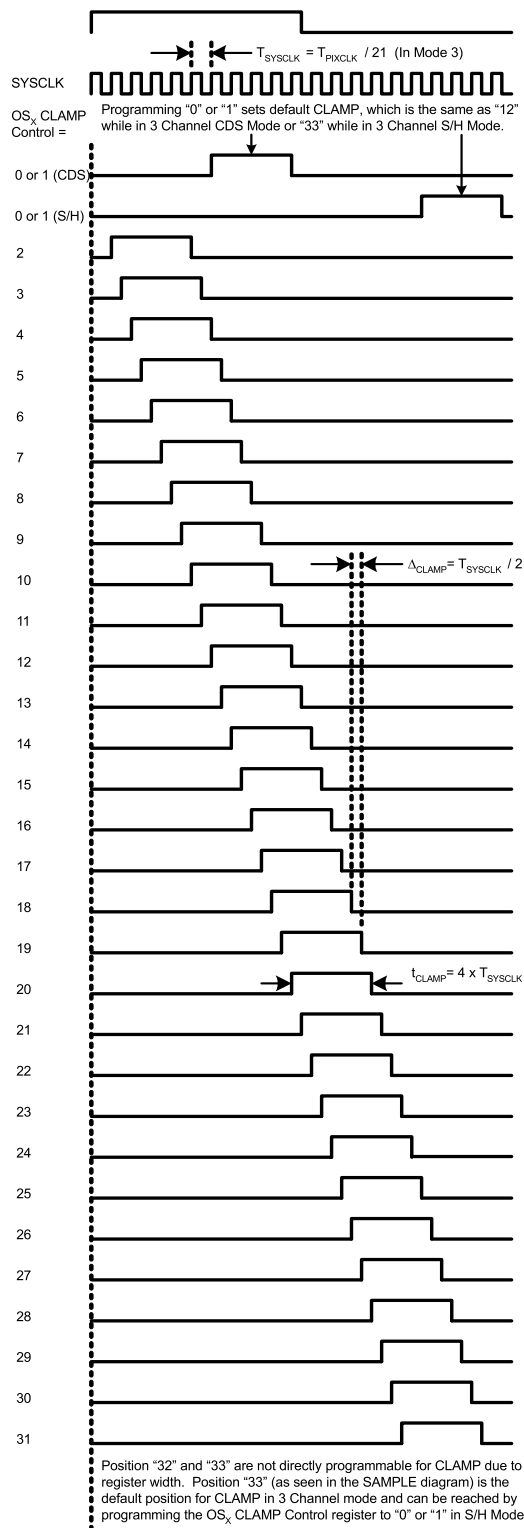

Figure 16. 3 Channel (Mode 3) CLAMP Timing

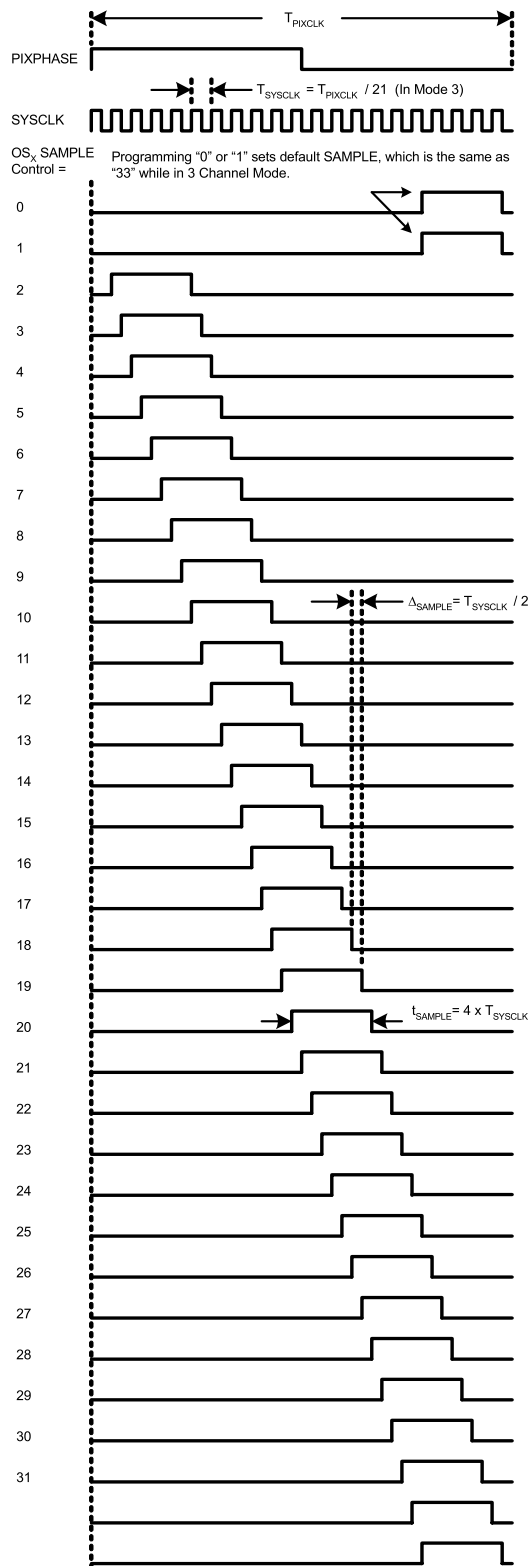

Figure 17. 3 Channel (Mode 3) SAMPLE Timing

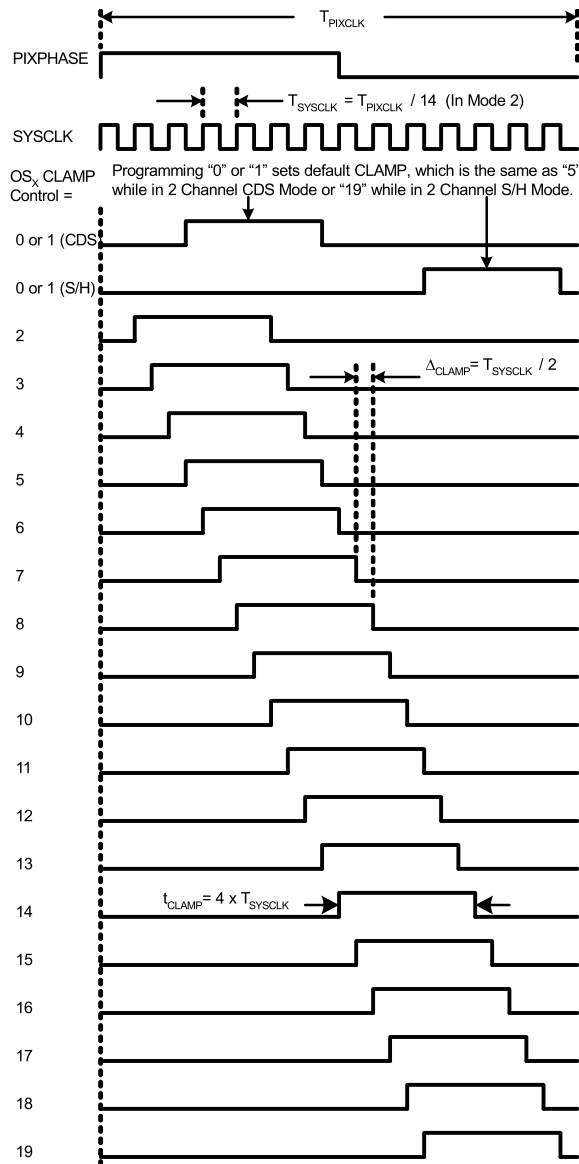

Figure 18. 2 Channel (Mode 2) CLAMP Timing

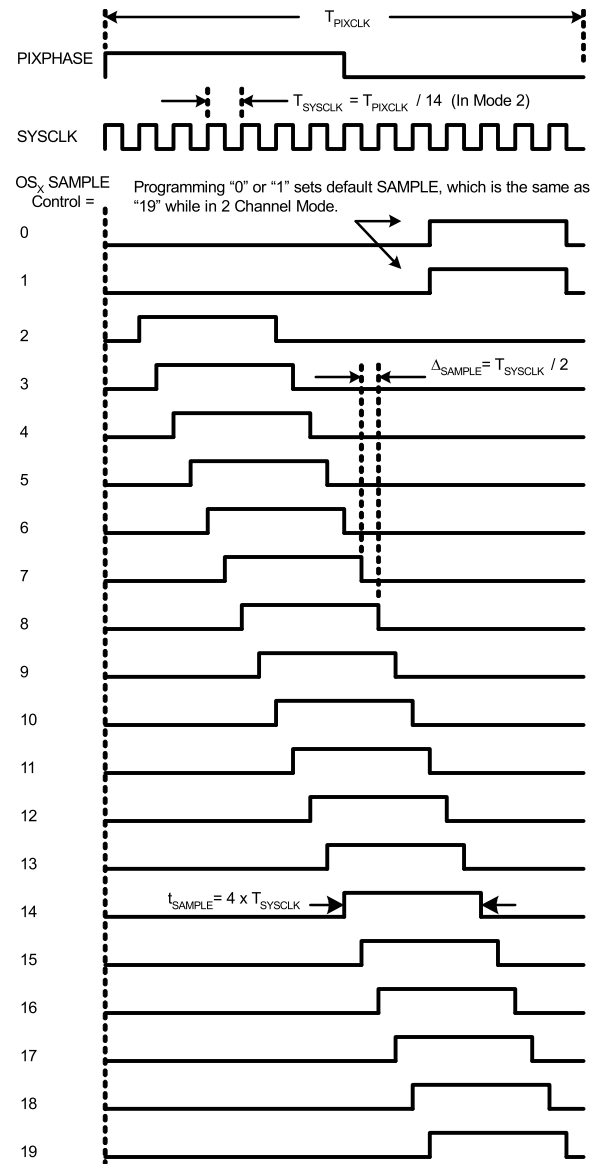

Figure 19. 2 Channel (Mode 2) SAMPLE Timing

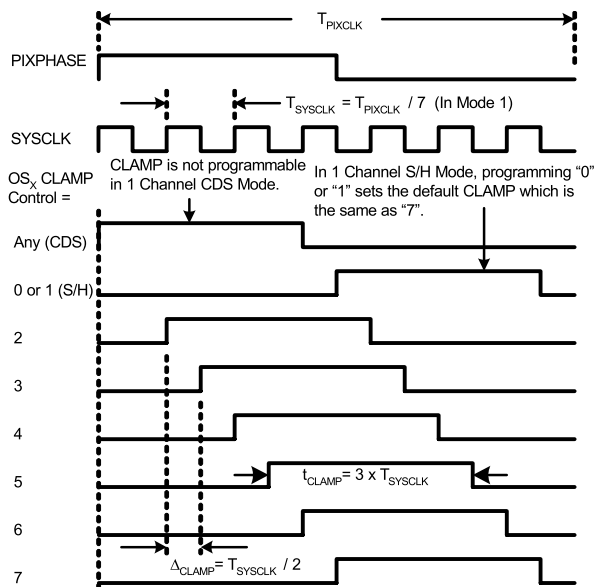

Figure 20. 1 Channel (Mode 1) CLAMP Timing

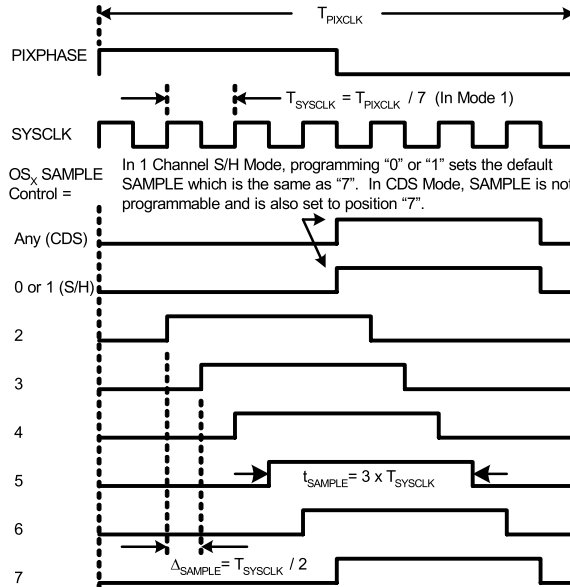

Figure 21. 1 Channel (Mode 1) SAMPLE Timing

7.3.6 Automatic Black Level Correction Loop

CCD signal processors require a reference level for the proper handling of input signals; this reference level is commonly referred to as the black level. The LM98714 provides an Automatic Black Level Correction Loop as shown in Figure 22. The timing for this function is shown in Figure 23. The loop can be disabled and the Black Level Offset DAC registers programmed manually if desired.

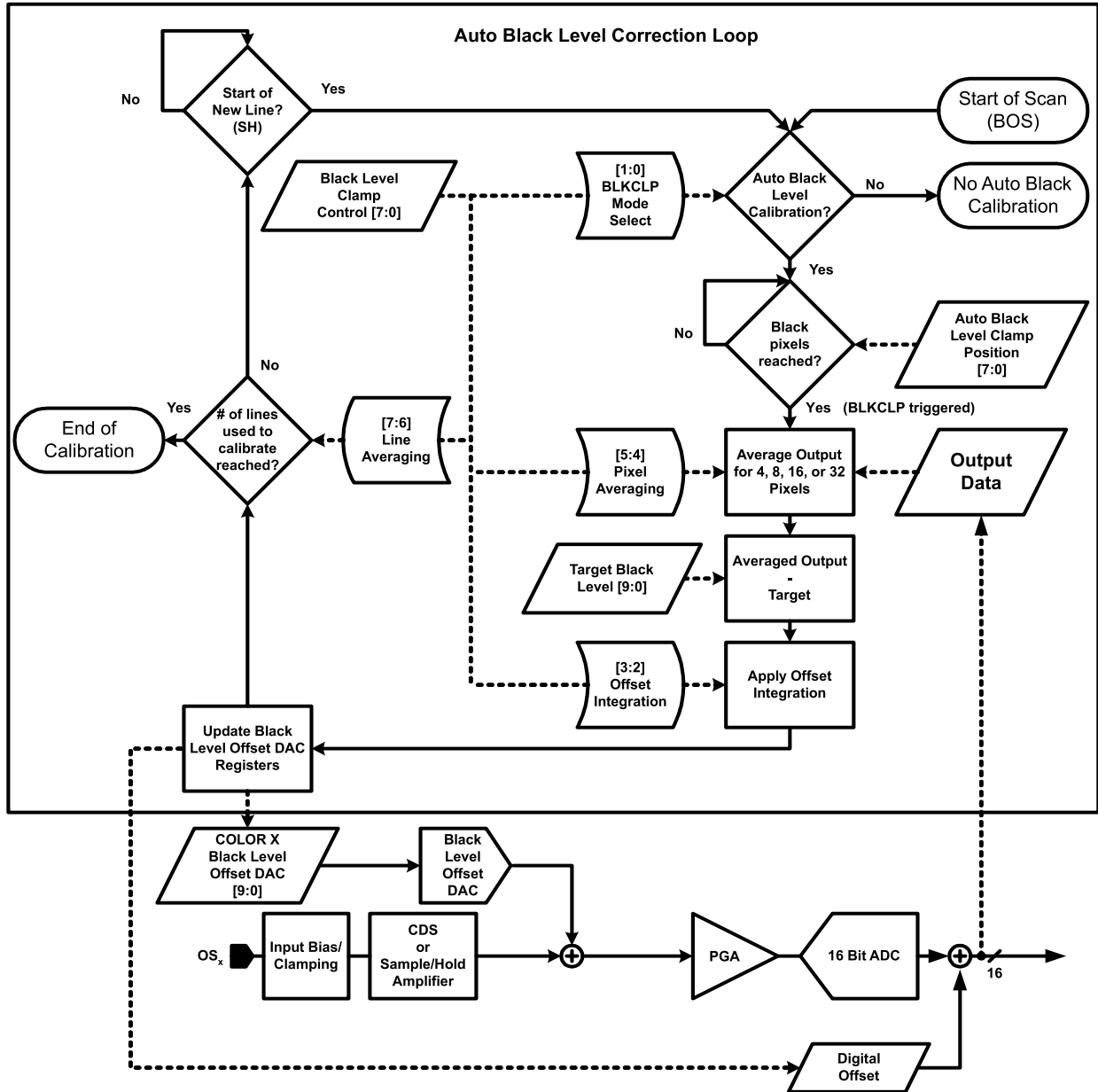

Figure 22. Black Level Correction Loop

The loop is intended to be used prior to scanning the page or during the first several lines at the beginning of a scan. The loop calibrates the channel offset such that the ADC outputs the desired code for Optical Black Pixels. In automatic mode, the pixels used to calibrate the offset should be Optical Black pixels represented by the internal “BLKCLP” pulse in Figure 23.

7.3.6.1 Black Level Offset DAC

The offset level registers store the DAC value required to meet the respective channel's black level output. While using the Auto Black Level Correction Loop, the DAC registers are re-written as required every line the loop is enabled.

7.3.6.2 Black Level Clamp (BLKCLP)

The BLKCLP pulse can be synchronized by either the falling edge of the SH pulse or the CLPIN pulse (both shown in Figure 23). The automatic BLKCLP pulse will begin “n” number of pixel periods after the falling edge of the reference pulse where “n” is the Auto Black Level Clamp Position register. The reference point is programmed by the BLKCLP Mode Select Bits[1:0] within the Black Level Clamp Control register. The BLKCLP pulse should not be programmed coincident to the CLPIN pulse (if the CLPIN pulse is being used).

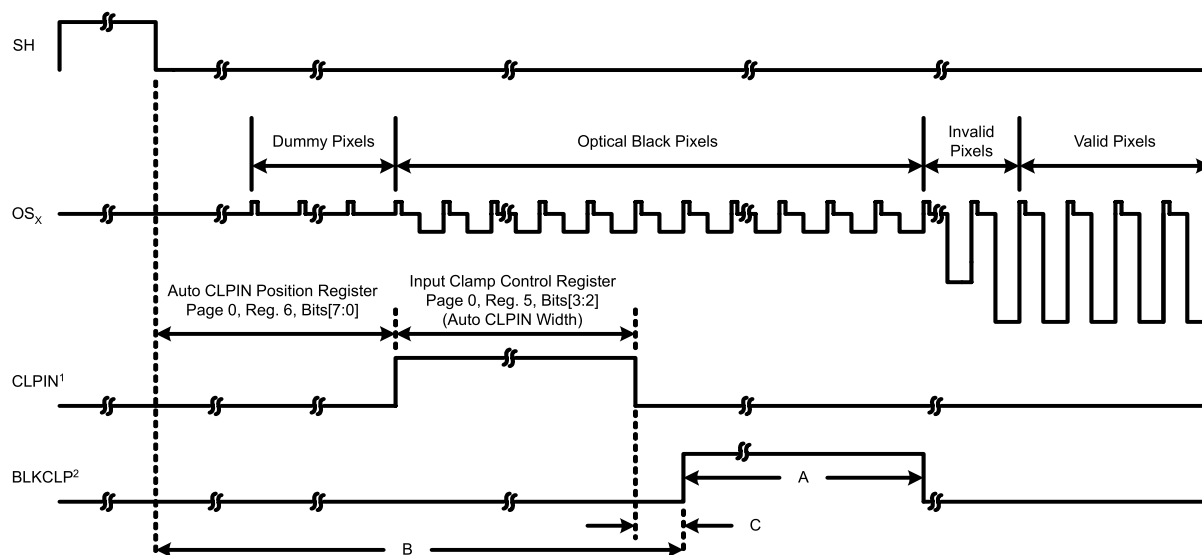

1. CLPIN is an optional input clamping signal. If CLPIN is used, the Black level Calibration Loop should be triggered after CLPIN returns low during Optical Black Pixels.
2. BLKCLP represents the time during a line where the Black level Calibration Loop is active. BLKCLP can be programmed to begin relative to the falling edge of SH or the falling edge of CLPIN (if CLPIN is being used).

A = Number of Optical Black Pixels the Black Level Calibration Loop averages per line. It is configured by the Black Level Clamp Control Register (Page 0, Reg. 8, Bits[5:4]).

B = Black Level Clamp Position with delay from SH. Auto Black Level Clamp Position (Page 0, Reg. 9) and BLKCLP Mode Select (Page 0, Reg. 8, Bits[1:0]) = 01b

C = Black Level Clamp Position with delay from CLPIN. Auto Black Level Clamp Position (Page 0, Reg. 9) and BLKCLP Mode Select (Page 0, Reg. 8, Bits[1:0]) = 10b

Figure 23. Black Level Correction Timing

7.3.6.3 Pixel Averaging

In order to obtain a snapshot of the current value for black (for comparison with the desired level of black) the ADC output is sampled upon activation of BLKCLP. Since a single optical black pixel is unlikely to be an accurate representation of the black level, a number of adjacent pixels are averaged. The number of pixels sampled is programmable by the Pixel Averaging Bit[5:4] within the Black Level Clamp Control register. The ability to select the number of pixels to be averaged (4, 8, 16, or 32 per line) provides greater flexibility allowing the LM98714 to be used with different CCDs having differing number of black pixels.

7.3.6.4 Target Black Level

The Target Black Level registers define a 10-bit word that specifies an ADC output (on the 12 bit level) corresponding to the desired optical black output code (ignoring the four LSBs of the 16 Bit ADC output). In other words, one Target Black Level LSB corresponds to sixteen ADC LSBs. Assertion of the BLKCLP signal activates the digital black clamp loop and the black level is steered toward the value stored in the output black level register. The digital black clamp loop is only limited in its range by the offset DAC's range.

Once the correct number of pixels have been averaged, the value is subtracted from the Target Black Level and an error value is produced.

7.3.6.5 Offset Integration

Each time the BLKCLP signal is activated, the average ADC output of several black pixels is compared to the Target Black Level producing an error value. This error value is not directly added (or subtracted) to the Black Level Offset register, rather, the value applied is a programmable fraction of this error. This has the effect of slowing down the offset convergence resulting in a calculation for offset that is less susceptible to noise. The scaling factor is stored in the Offset integration Bits[3:2] of the Black Level Clamp Control register. The scaling values are divided-by-8, 16, 32, or 64. Divide-by-8 provides the quickest convergence of the loop (for use when the number of lines available for calibration is limited) and Divide-by-64 the longest (for use when using a large number of lines to converge).

7.3.6.6 Line Averaging

The Auto Black level Correction Loop can be run for 15 lines, 31 lines, 63 lines, or infinite (every line). The Line Averaging Bits[7:6] found in the Black Level Clamp Control register set the number of lines that the loop will run after the Start of Scan. The recommended use of the Auto Black Level Correction Loop is in a calibration period prior to moving the sensor down the page or during the first several lines of the page. By experimenting with the Line Averaging and Offset Integration bits with no sensor illumination (black pixels), the proper settings for the Auto Black Level Correction Loop are determined when the ADC output converges to the Target Black Level value. If the loop converges with the 15, 31, or 63 line setting, the loop can remain enabled. The loop does not update the Black Level Offset DAC once the number of lines since "Start of Scan" has passed. If the loop requires more than 63 lines to converge (i.e. requires Line Averaging = infinite), it is recommended to disable the loop after convergence has been reached. In the "infinite" setting, the loop will continuously update the Black Level Offset registers as long as the loop is enabled throughout the entire scan.

7.3.7 Internal Timing Generation

A flexible internal timing generator is included to provide clocking signals to CCD and CIS sensors. A block diagram of the CCD Timing Generator is shown in Figure 24.

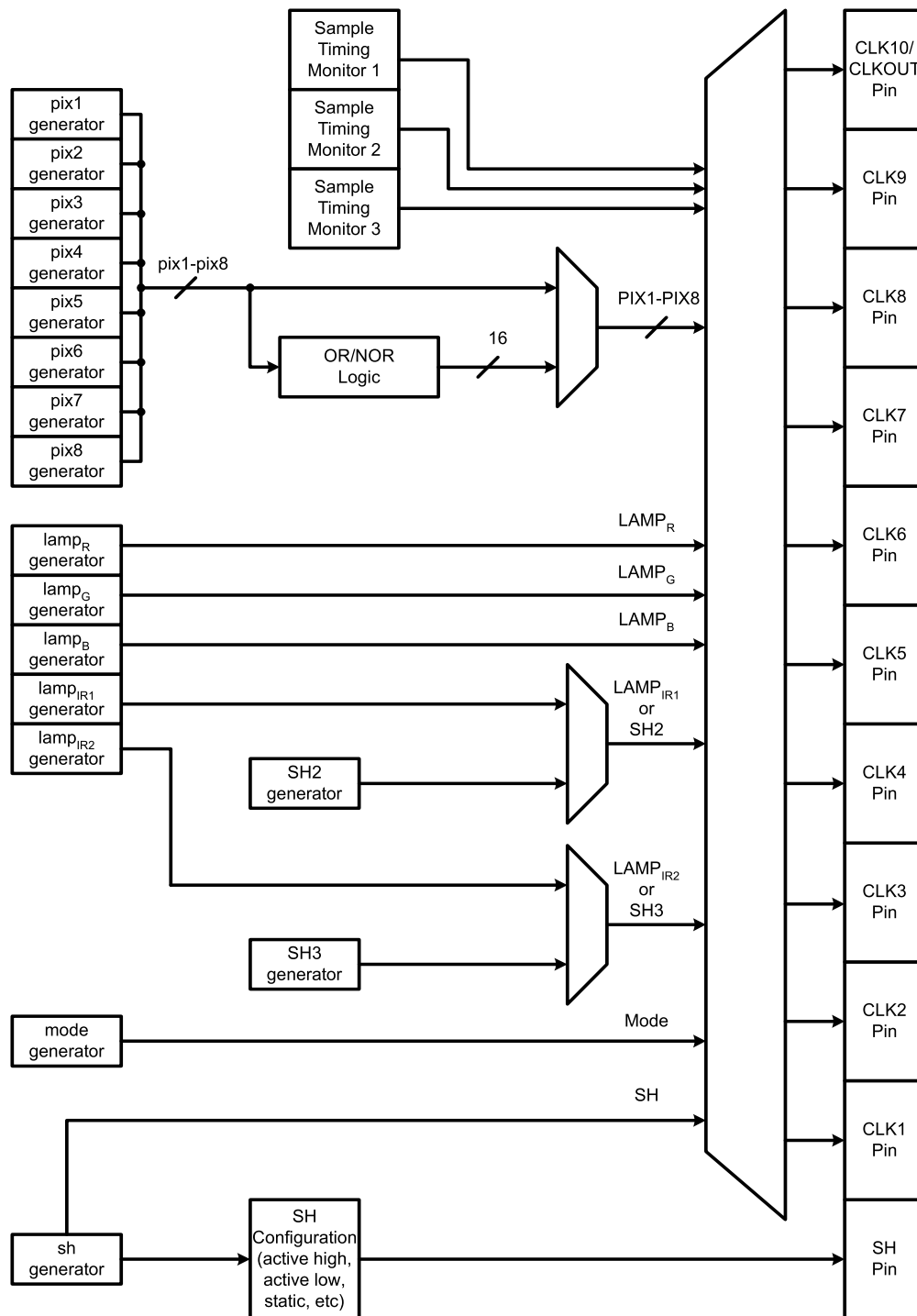
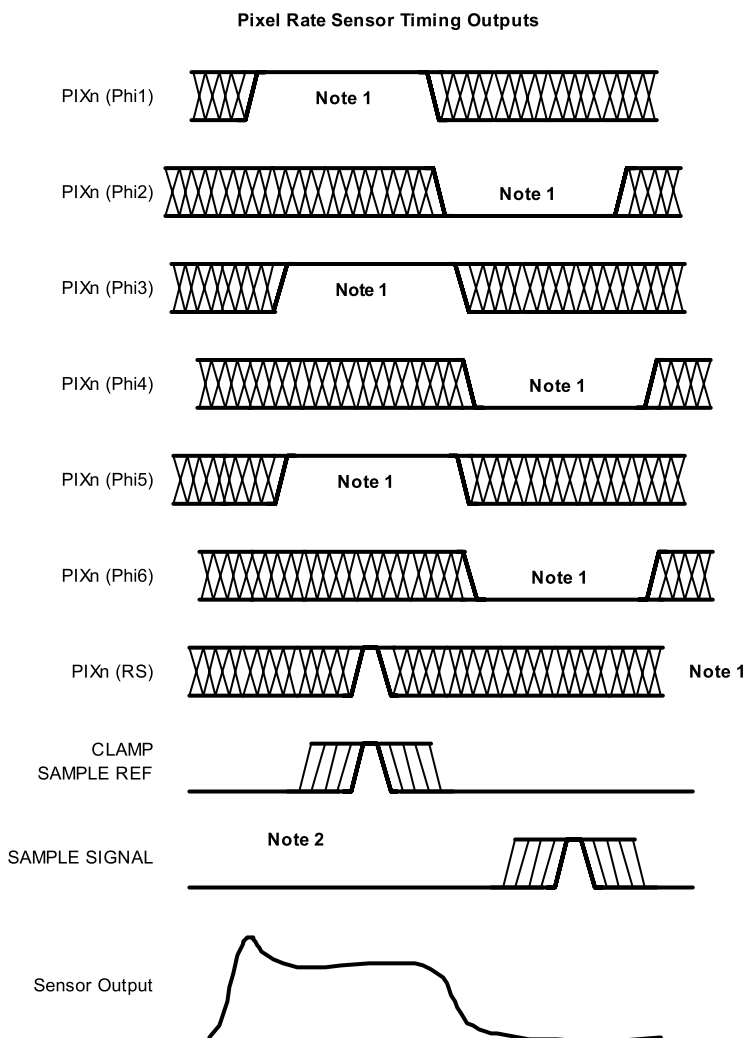

Figure 24. CCD Timing Generator Block Diagram

Examples of the various operating modes and settings are shown following. The detailed pixel timing is somewhat dependent on the operating modes of the AFE circuitry regarding the number of adjustment points for the on and off points of the different timing outputs.

NOTE

In addition to the timing adjustments shown, the polarity of all sensor clock signals can be adjusted by register control.



Note 1: PIXn rising and falling edges can be independently adjusted to any available point within the pixel period. Duration, duty cycle and position can all be adjusted as required. To ensure 50% duty cycle is possible, the internal clock system provides an even number of edges in all modes.

Note 2: CLAMP and SAMPLE signals have several available positions (see detailed AFE timing mode diagrams), but duration is fixed by design.

Note 3: The number of available edges for timing adjustments is dependent on the AFE operating mode.

Figure 25. Sensor Timing Control - Pixel Details - 1 Pixel per Phi

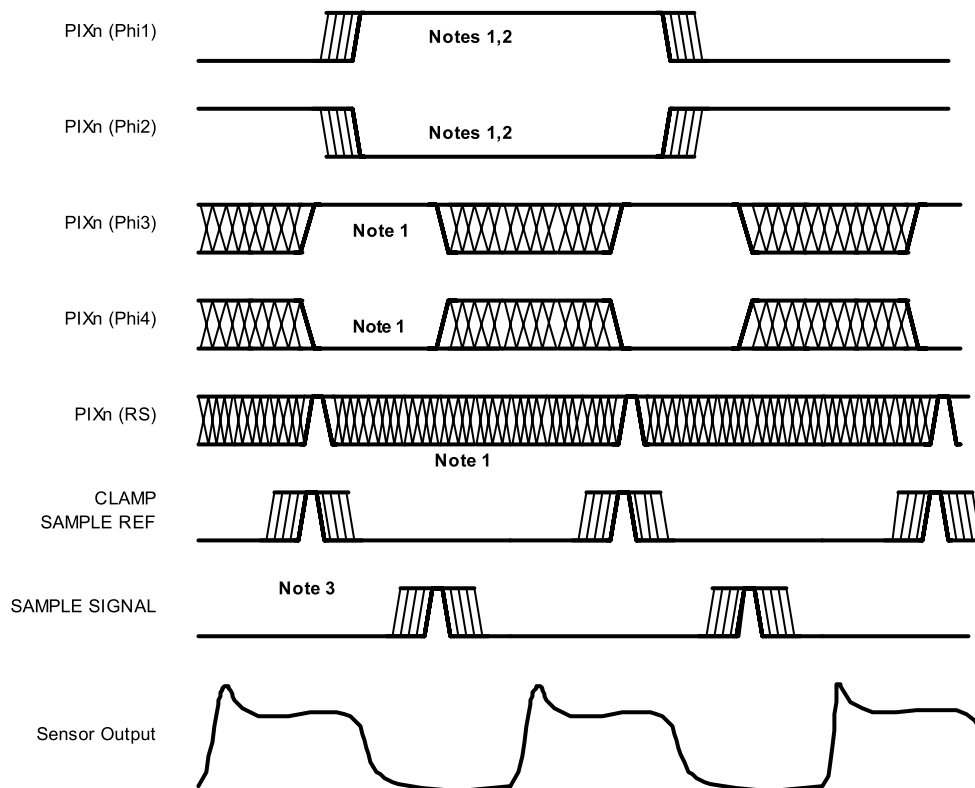

Note 1: PIXn rising and falling edges can be independently adjusted to any available point within the 2 pixel period. Duration, duty cycle and position can all be adjusted as required. To ensure 50% duty cycle is possible, the internal clock system provides an even number of edges in all modes.

Note 2: Each PIXn can be adjusted to have a frequency equal to or 1/2 that of the pixel frequency. In that case, rising and falling edges can be adjusted to any available edge within the 2 pixel interval.

Note 3: CLAMP and SAMPLE signals have several available positions (see detailed AFE timing mode diagrams), but duration is fixed by design.

Note 4: The number of available edges for timing adjustments is dependent on the AFE operating mode.

Figure 26. Sensor Timing Control - Pixel Details - 2 Pixels per Phi

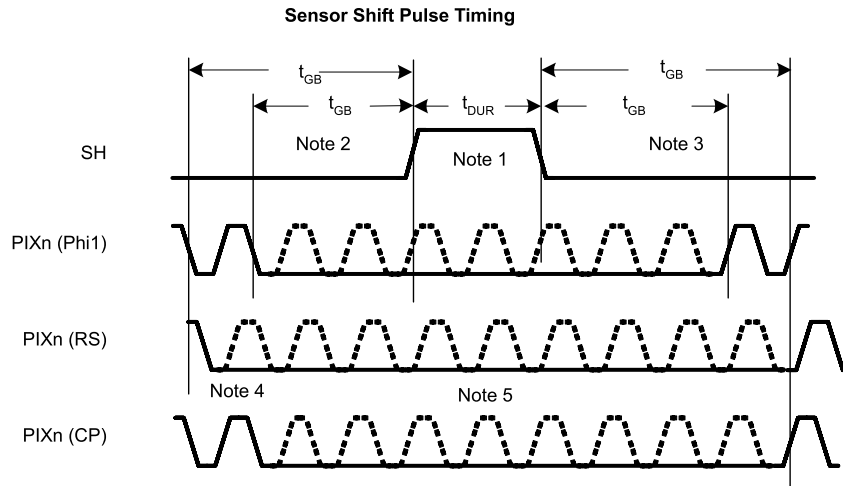

- Note 1: SH duration can be adjusted.
 - Note 2: Guardband from end of PIX timing signal to start of SH can be selected individually for each PIX timing signal. Range of adjustment is 0 to 255 pixel periods.
 - Note 3: Guardband from end of SH to start of PIX timing signal can be selected individually for each PIX signal. Range of adjustment is 0 to 255 pixel periods.
 - Note 4: The detailed timing of each PIX signal is adjustable to any available PLL clock edge within the pixel period. Refer to PIX timing details.
 - Note 5: Each PIX signal can be selected as Inactive or Active during the SH pulse interval.
- *RS and CP must be inactive during SH when using Toshiba CCD sensors.

Figure 27. Sensor Timing SH Pulse Details

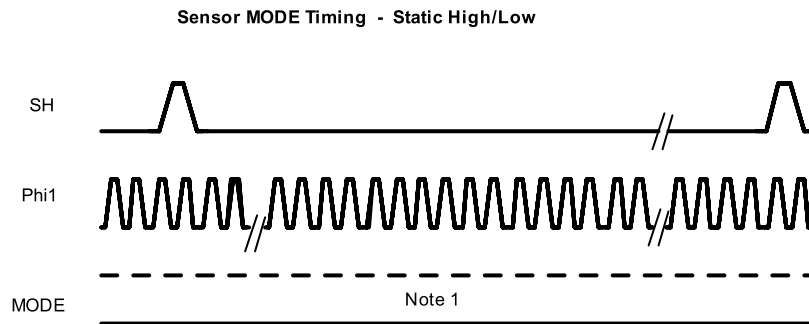

- Note 1: MODE can be programmed to be static high or low.

Figure 28. Sensor Timing Mode Pin Output Details - Static High/Low

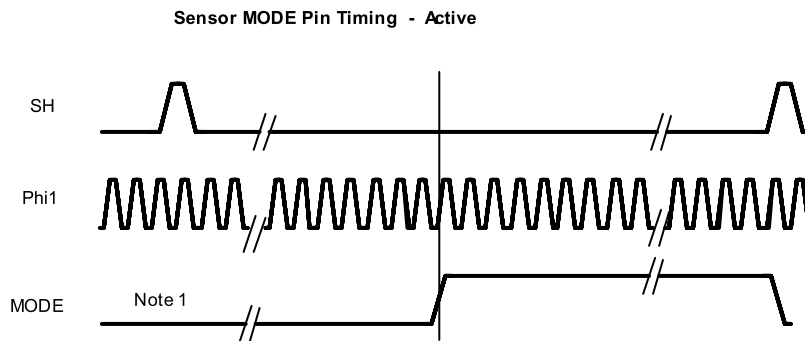

Note 1: MODE can be programmed to transition after a certain number of pixels have been clocked. This can be configured by register setting anywhere from pixel 1 to line end pixels. Polarity can be configured for initially low or initially high.

Figure 29. Sensor Timing Mode Pin Output Details - Active Programmed Transition

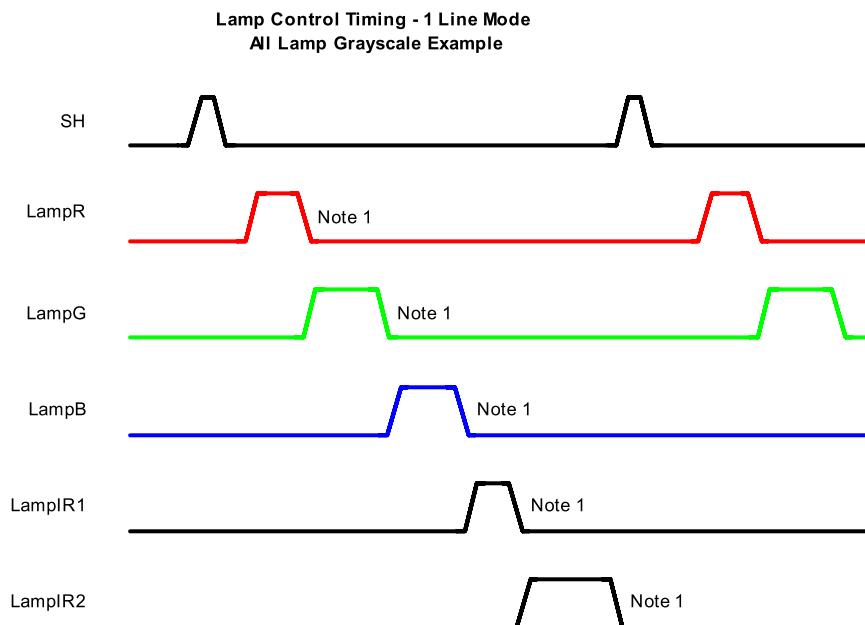

Note 1: LampR, LampG, LampB, LampIR1 and LampIR2 each turn on and off every line. The On and Off points are individually programmed for each Lamp output. *Lamps can be on simultaneously if desired and permitted by the CIS and system design.

Figure 30. Lamp Control Timing - 1 Line Mode (Monochrome)

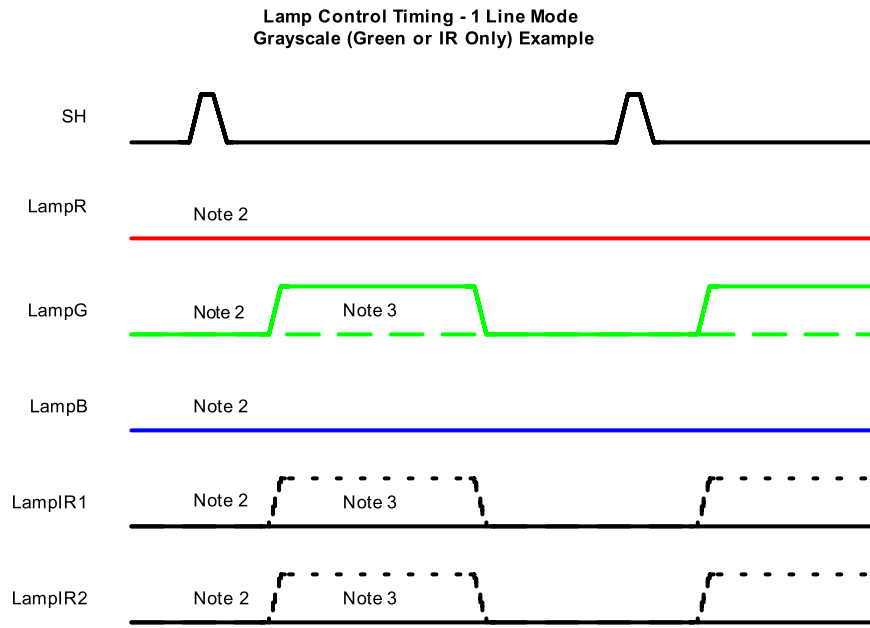

Note 1: LampR, LampG and LampB, LampIR1, and LampIR2 each turn on and off every line. The On and Off points are individually programmed for each Lamp output. *Lamps can be on simultaneously if desired and permitted by the CIS and system design.
 Note 2: For Green only lamp mode, the settings for LampR, LampB, LampIR1 and LampIR2 can be set so that those lamps are always off.
 Note 3: For IR scanning modes, the settings for LampR, LampG and LampB can be set so that those lamps are always off.

Figure 31. Lamp Control Timing - 1 Line Mode

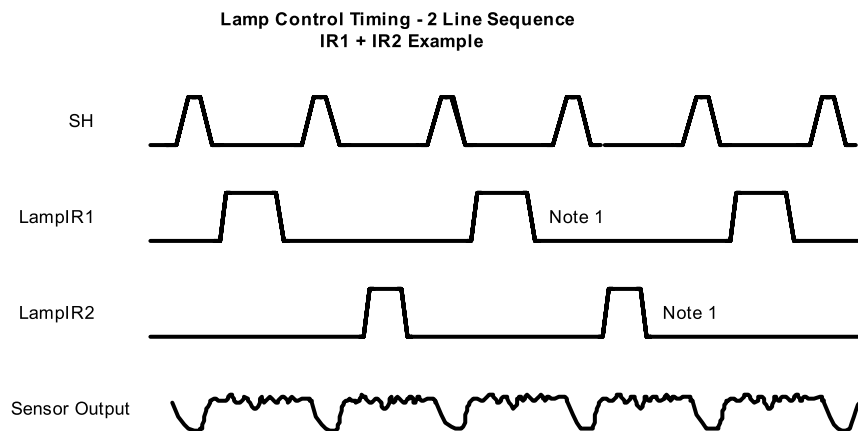

Note 1: In 2 line sequence mode, the Lamp outputs turn on sequentially, with the selected outputs on each line. Lamp On and Off points can be set individually via register control. Polarity is also selectable by register control.

Figure 32. Lamp Control Timing - 2 Line Sequence

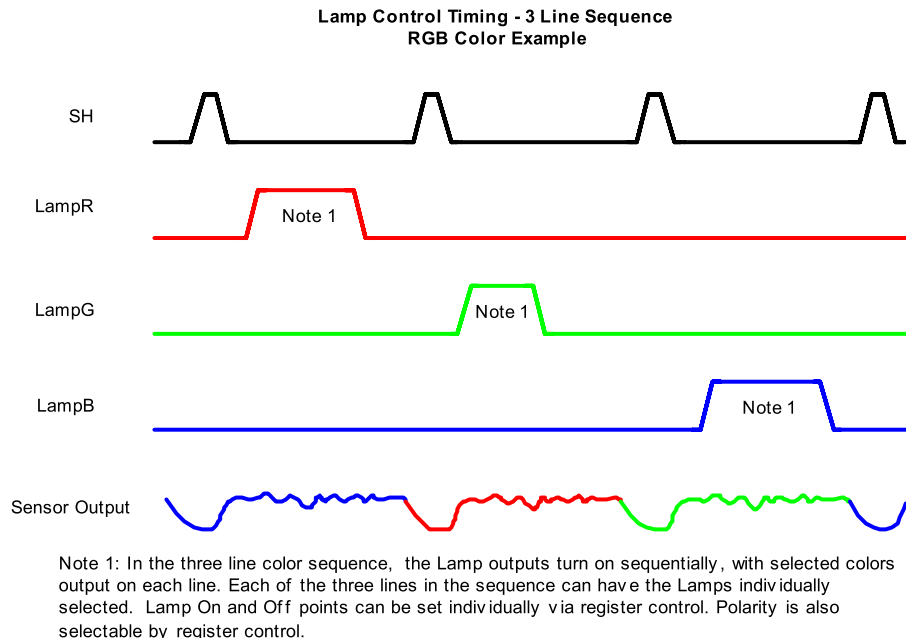

Figure 33. Lamp Control Timing - 3 Line Sequence

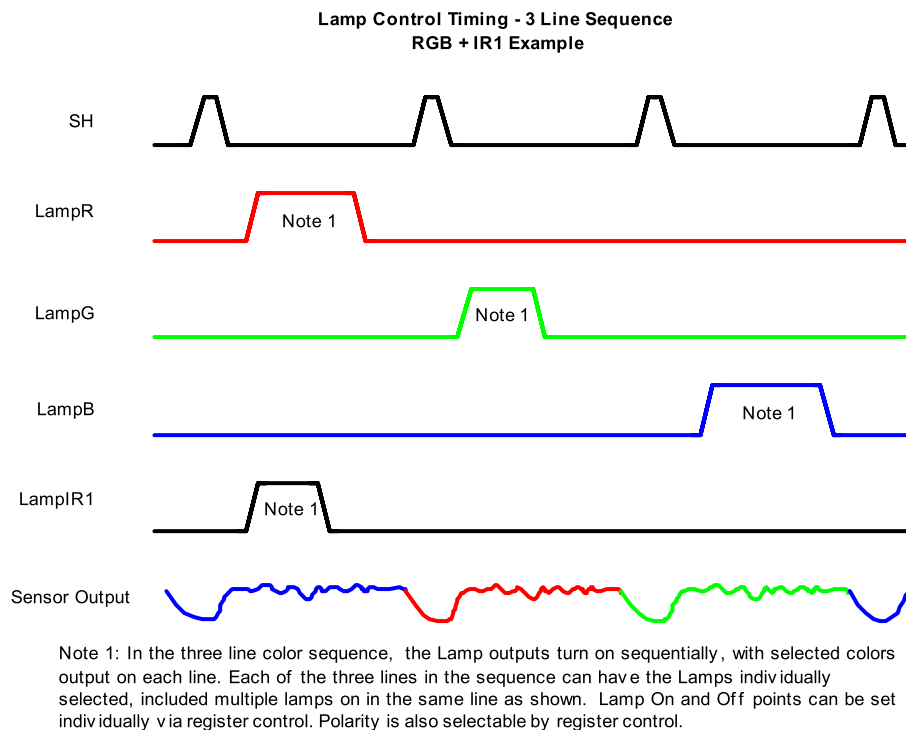
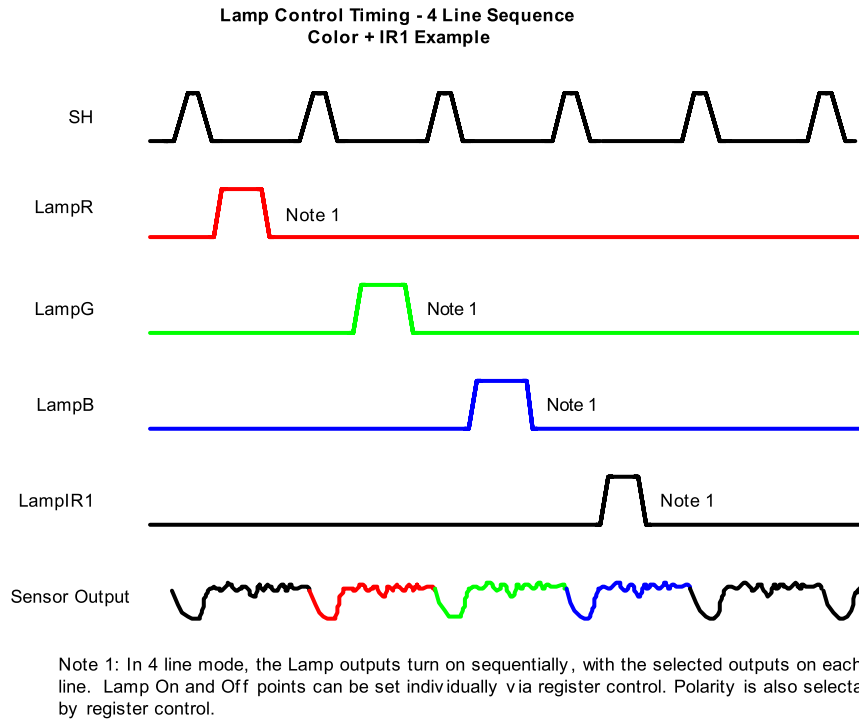
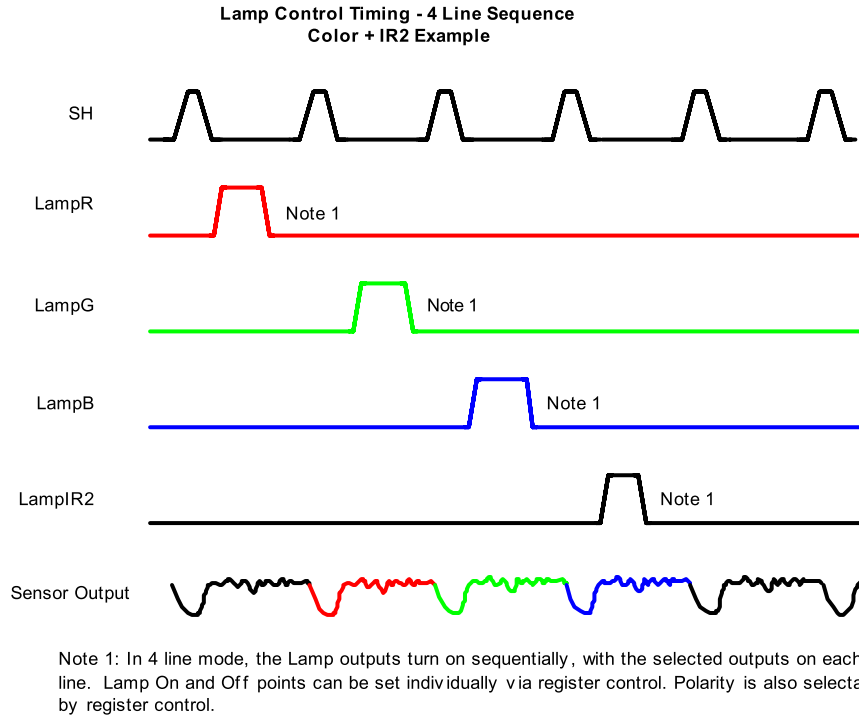

Figure 34. Lamp Control Timing - 3 Line Sequence - IR Enhancement Example



**Figure 35. Lamp Control Timing - 4 Line Sequence
Color + IR1 Example**



**Figure 36. Lamp Control Timing - 4 Line Sequence
Color + IR2 Example**

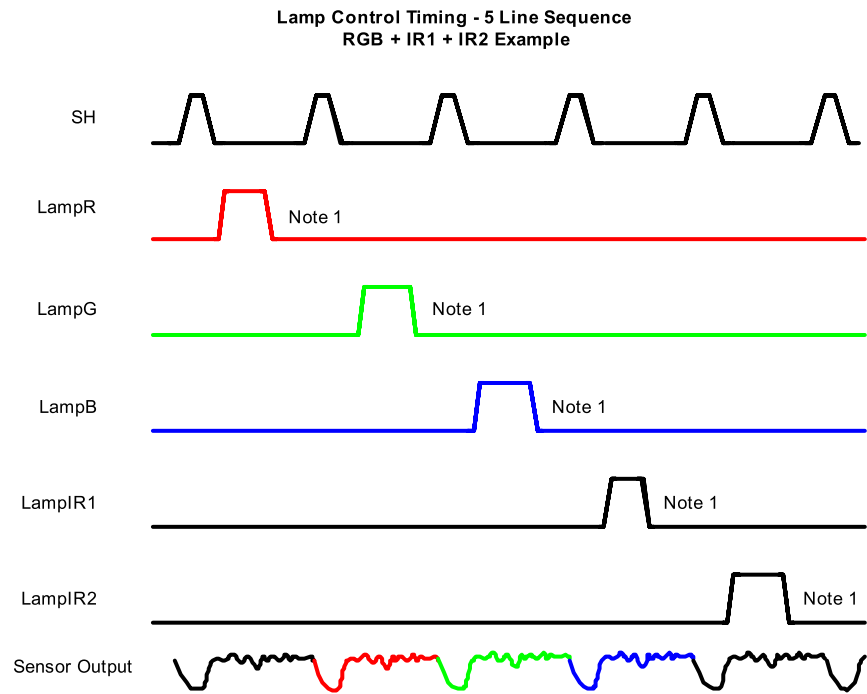

Note 1: In 5 line lamp mode, the Lamp outputs turn on sequentially, with the selected Lamps on each line. Lamp On and Off points can be set individually via register control. Polarity is also selectable by register control.

Figure 37. Lamp Control Timing - 5 Line Sequence

7.3.7.1 Pix Signal Generator OR/NOR Modes

As shown in Figure 24, the PIX signal generators outputs can be used in their normal form and sent to the LM98714 output pins, or, they can be sent through an additional layer of OR and NOR logic to provide a number of clocking variations. The OR and NOR combinations of multiple PIX signals can be useful for such modes as pixel lumping, or other modes where more complicated phi clocks are required.

The OR and NOR functions are chosen through the PIX OR/NOR Control 1 and PIX OR/NOR Control 2 registers on Page 4 of the serial interface register map. When all of the OR/NOR control bits are 0 (default) the PIX signals are sent directly from the pix signal generators to the output pins configured by the Output Mapping Control registers (register Page 3). When an OR/NOR control bit is set to 1, the OR or NOR product of multiple pix signal generators is routed to the output pin described in the register details.

7.3.7.2 SH2 and SH3 Generation

In some sensors, there is a requirement for up to three “SH” type signals. The LM98714 CCD Timing Generator can be configured to produce optional SH signals as shown in Figure 38, these SH signals (SH2 and SH3) toggle every other line and are coincident with the original SH pulse.

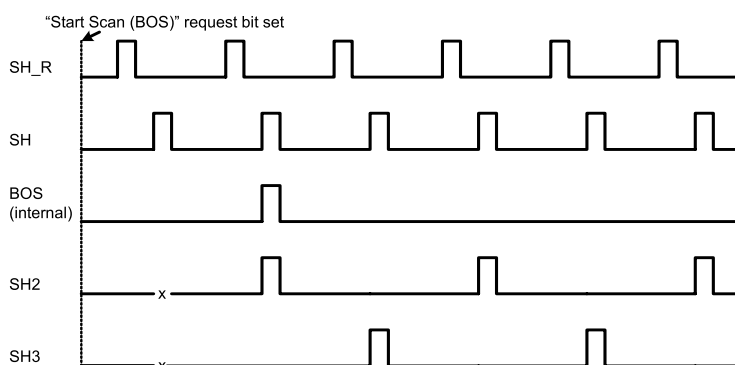

Figure 38. SH2 and SH3 Generation

The “Start Scan (BOS)” request bit is used to begin the proper sequence of CCD Timing outputs at the beginning of a scan. The first line of pixels are being processed by the CCD during the first integration period (after the first SH). The BOS signal (internal to the LM98714) occurs at the second SH to signal when the first line of pixels are actually shifting out of the CCD and in to the AFE. The SH2 pulse is synchronized with the BOS signal and continues to toggle on an every other line basis. The SH3 signal occurs on opposite lines from SH2.

The SH2 and SH3 signals are available in place of the Lamp IR1 and Lamp IR2 outputs respectively. The routing of SH2 and SH3 is depicted in Figure 24. The use of SH2 and SH3 is selected by the SH2/SH3 Control register (0x0F) on Page 4 of the register map.

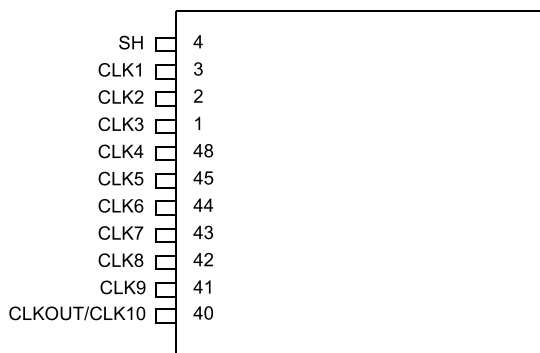

Figure 39. Sensor Control Outputs

Table 3 shows a number of example mappings of the sensor timing signals to the sensor control CLKn outputs. Several typical timings are shown here, but any timing generator signal can be mapped to any of the CLKn outputs, providing maximum flexibility.

Table 3. Sensor Timing Mappings Examples

Sensor Control Output	Example A	Example B	Example C	Example D	Example E	Example F
SH	SH	SH	SH	SH	SH	SH
CLK1	PIX1(PHI1)	PIX1(PHI1)	PIX1(PHI1)	PIX1(PHI1)	PIX1(PHI1)	PIX1(PHI1)
CLK2	PIX2(PHI2)	PIX2(PHI2)	PIX2(PHI2)	PIX2(PHI2)	PIX2(PHI2)	PIX2(PHI2)
CLK3	PIX3(RS)	PIX3(RS)	PIX3(RS)	PIX3(RS)	PIX3(PHI3)	PIX3(RS)
CLK4	PIX4(CP)	PIX4(CP)	LAMP _R	PIX4(CP)	PIX4(PHI4)	PIX4(CP)
CLK5	LAMP _R	LAMP _R	LAMP _G	LAMP _R	PIX5(PHI5)	CB[0]
CLK6	LAMP _G	LAMP _G	LAMP _B	LAMP _G	PIX6(PHI6)	CB[1]
CLK7	LAMP _B	LAMP _B	LAMPIR1	LAMP _B	PIX7(RS)	CB[2]
CLK8	MODE	LAMPIR1	LAMPIR2	LAMPIR1	PIX8(CP)	CB[3]
CLK9	PIX5(PHI3)	LAMPIR2	MODE	LAMPIR2	MODE	CB[4]
CLKOUT/CLK10		(MODE)		PIX5(PHI3)		CLKOUT

These examples can be used for any customer need, but typical applications would be as follows:

In Examples A, B and C, only 10 sensor control outputs are used. This is to allow the CLKOUT/CLK10 pin to be used as a timing reference for the image output data when the outputs are in CMOS mode.

Example A: Used with most CCD or CIS sensors, including new sensors with 3 PHI clock inputs. Will support up to 3 color LED lamps. Supports CCD sensors with switchable resolution through the MODE control output.

Example B: Used in applications where up to 2 additional IR lamps are used in addition to the R, G, B lamps. No resolution MODE output is available.

Example C: Used where no CP pulse is needed, but 5 lamp outputs are needed as well as a MODE sensor resolution control pin.

In Examples D and E, the CLK10 output is also used. These modes are not available when the image data outputs are operating in CMOS mode.

Example D: Provides both PHI3 output and 5 LED lamp outputs. Does not provide MODE output for resolution control.

Example E: Provides 5 LED lamp outputs, and the MODE output for sensor resolution control.

7.3.8 CCD Timing Generator Master/Slave Modes

The internal CCD Timing generator is capable of operating in Master Mode or in Slave Mode. The Master/Slave operation is configured with the SH Mode Register (Register 0x00 on Page 2). In either Master or Slave Mode, control bit data can be sent to the output of the LM98714 to indicate when each new scan is starting as well as pixel information such as color, type (active, black, dummy, etc.), and the beginning of each line.

7.3.8.1 Master Timing Generator Mode

In Master Timing Mode, the LM98714 controls the entire CCD Timing Generator based on a Start Scan Bit (Main Configuration Register 2, Bit[0] is the “Start Scan” or “BOS/Beginning of Scan” bit). The Start Scan bit is set by the user to request a new scan. This bit is a self clearing register bit written to the serial interface. When received, the LM98714 controls where and when each new line of the scan begins and ends based on the CCD Timing Generator register settings. The scan is enabled as long as the Active/Standby bit is low. The period of the line (integration time) is controlled by the SH Width setting (SH Pulse Width Register) and the Line End setting (Line End MSB and Line End LSB registers).

7.3.8.2 Slave Timing Generator Mode

In Slave Timing Mode, the LM98714 CCD Timing Generator is controlled by the external SH_R pin. Each new line of a scan is initiated by an SH_R pulse. The period of the line (integration time) is mainly controlled by the period of the incoming SH_R signal.

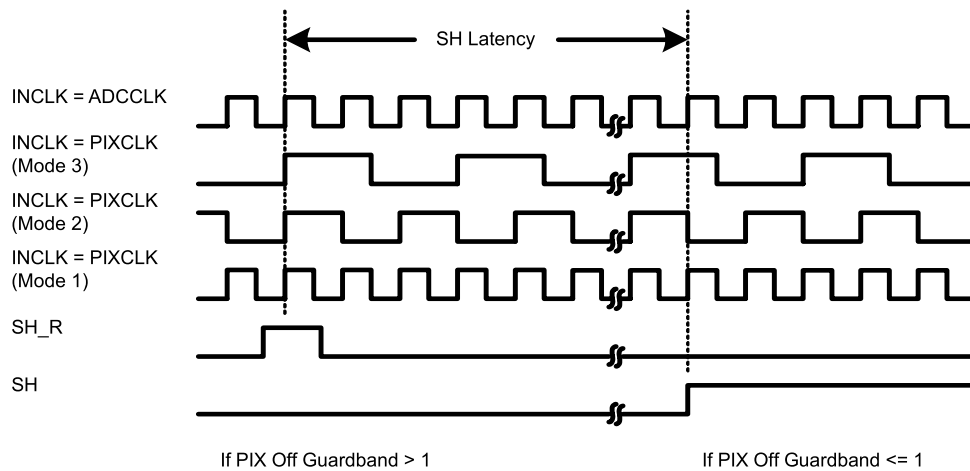

Mode 3 SH Latency = 4 ADCCLK + 3*PIX Off Guardband

Mode 3 SH Latency = 7 ADCCLK

Mode 2 SH Latency = 4 ADCCLK + 2*PIX Off Guardband

Mode 2 SH Latency = 6 ADCCLK

Mode 1 SH Latency = 4 ADCCLK + PIX Off Guardband

Mode 1 SH Latency = 5 ADCCLK

Note*: Latency is calculated with the largest programmed PIX Off Guardband value.

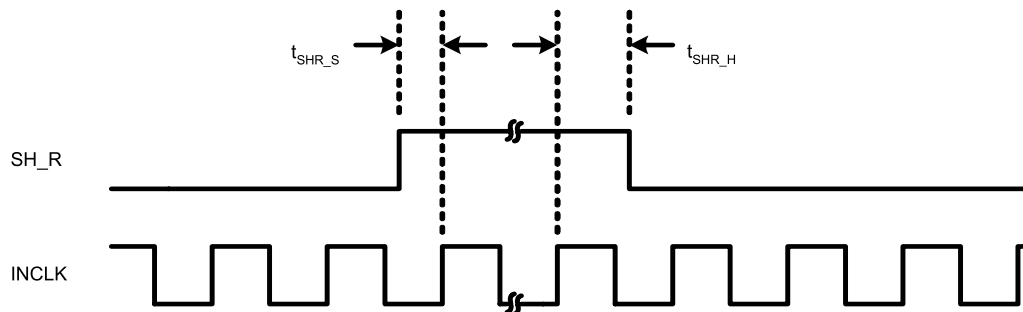
Figure 40. SH_R Input to SH Output Latency Diagram

Figure 41. SH_R to INCLK (PIXCLK or ADCCLK) Timing

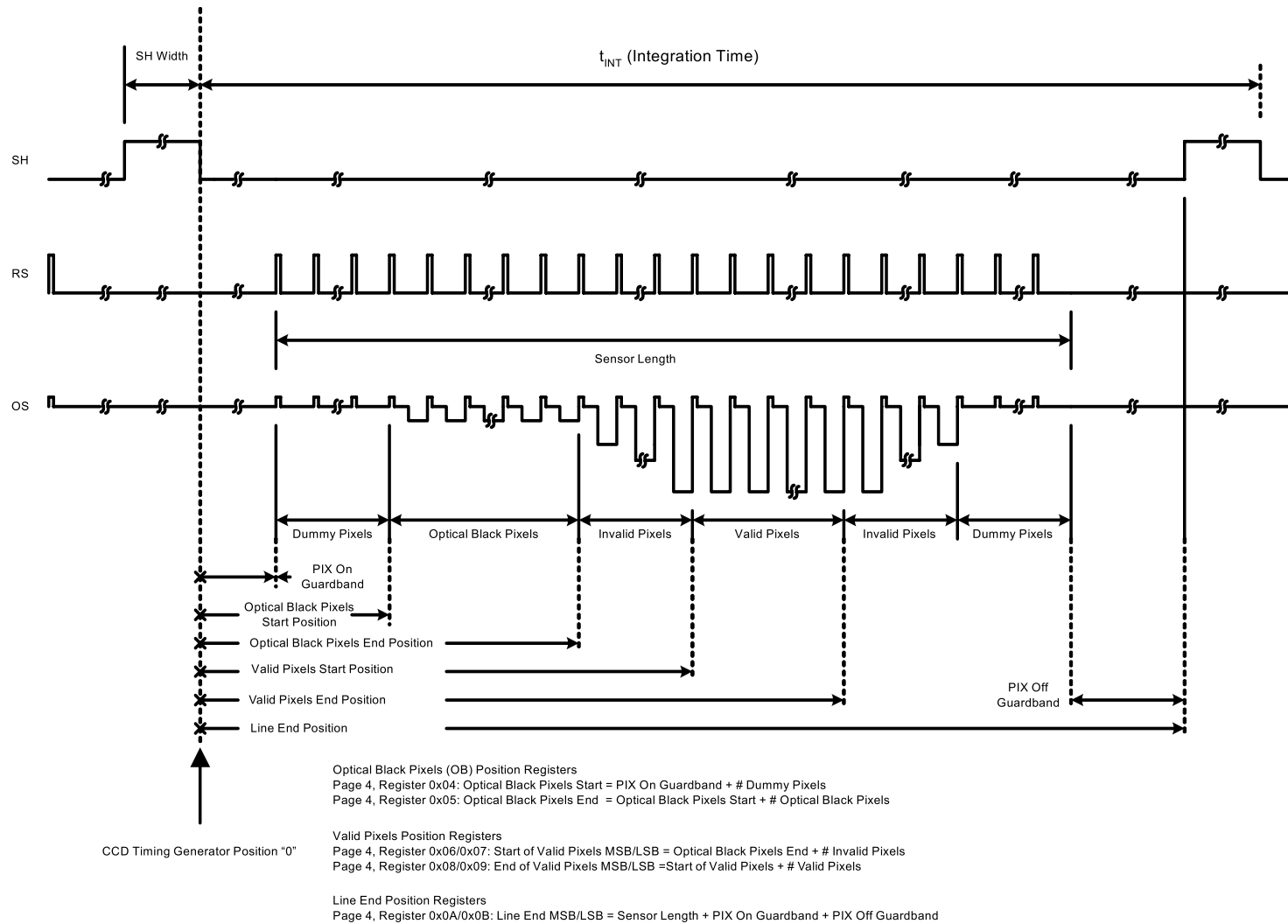

Figure 42. CCD Timing Generator Pixel Position Definition

7.3.9 LVDS Output Mode

7.3.9.1 LVDS Output Format

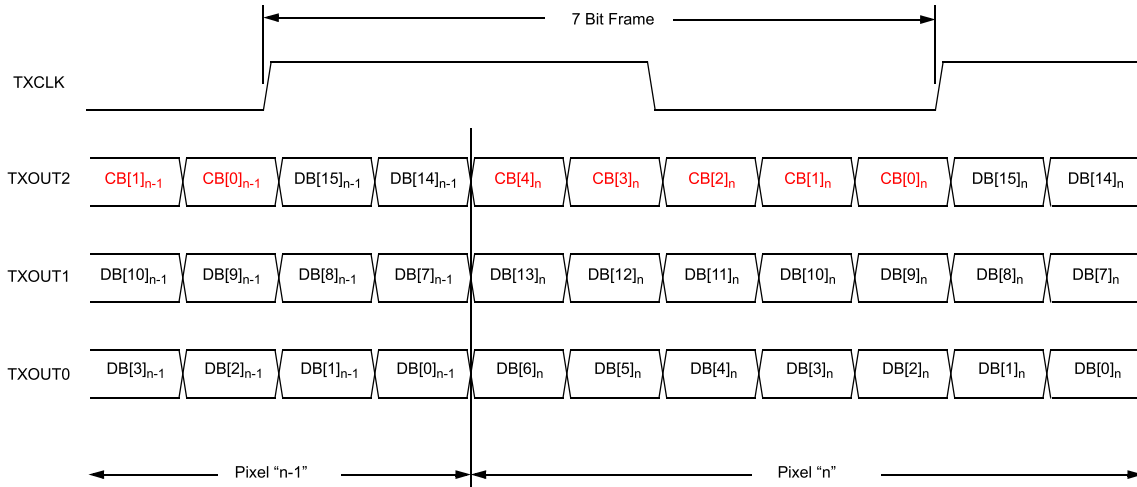

Figure 43. LVDS Output Bit Alignment and Data Format

7.3.9.2 LVDS Output Timing Details

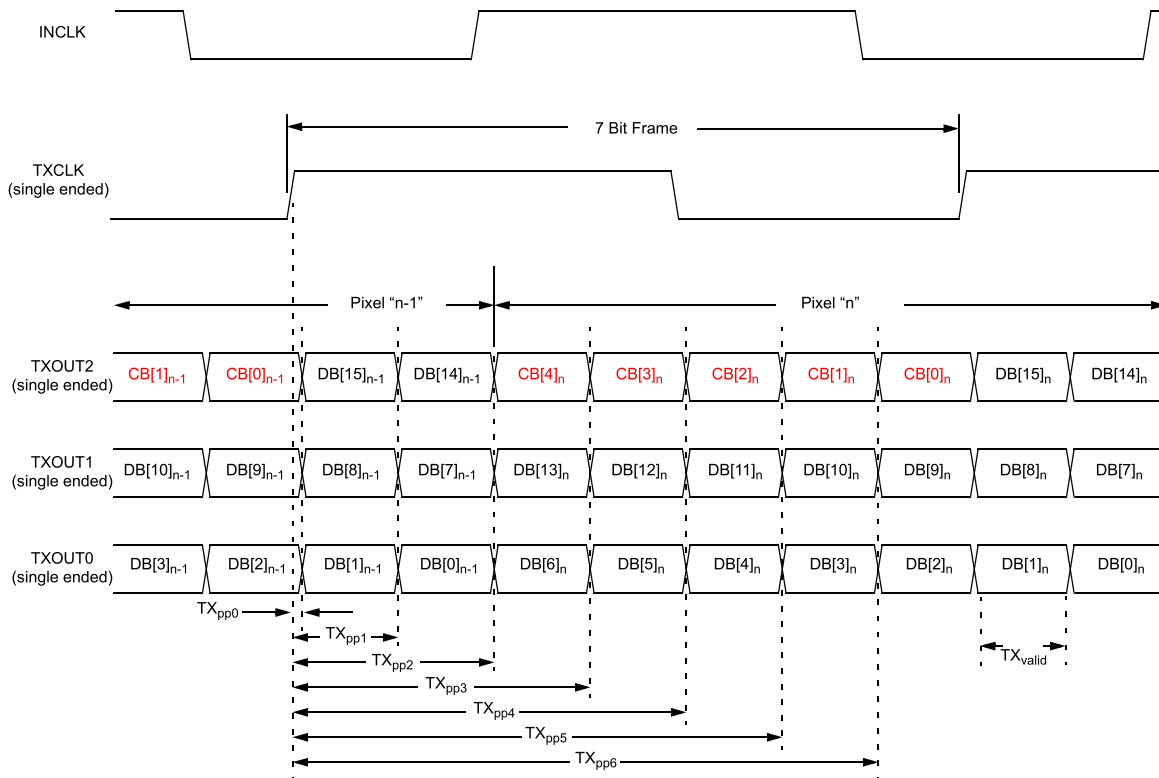

Figure 44. LVDS Data Output Mode Specification Diagram

7.3.9.3 LVDS Control Bit Coding

The 5 control bits included in the LVDS data stream are coded as follows:

The "active" and "black" pixel tags are programmable tags that the LM98714 provides in order to identify how many pixels have been processed since the falling edge of SH.

Which pixels are given "active" and "black" CB tags is controlled by Page 4, registers 0x08 through 0x0D (Optical Black Pixels Start, Optical Black Pixels End, Start of Valid Pixels, and End of Valid Pixels).

The LM98714 counts the number of pixel periods after the falling edge of SH: If the number of pixel periods after the falling edge of SH is between "optical black pixels start" and "optical black pixels end" the CB bits will indicate that the pixel is a black pixel. If the number of pixel periods after the falling edge of SH is between "start of valid pixels" and "end of valid pixels" the CB bits will indicate that the pixel is an active pixel.

Table 4.

CB[4]	Description
0	Not the beginning of line
1	Beginning of Line
	(This bit is high for as many pixels as SH pulse is active)

Table 5.

CB[3:0]	Description
0	Dummy Pixels
1	Red Active Pixels
10	Green Active Pixels
11	Blue Active Pixels
100	IR1 Active Pixels
101	IR2 Active Pixels
110	Red Black Pixels
111	Green Black Pixels
1000	Blue Black Pixels
1001	IR1 Black Pixels
1010	IR2 Black Pixels
1111	Beginning of Scan

7.3.9.4 LVDS Data Latency Diagrams

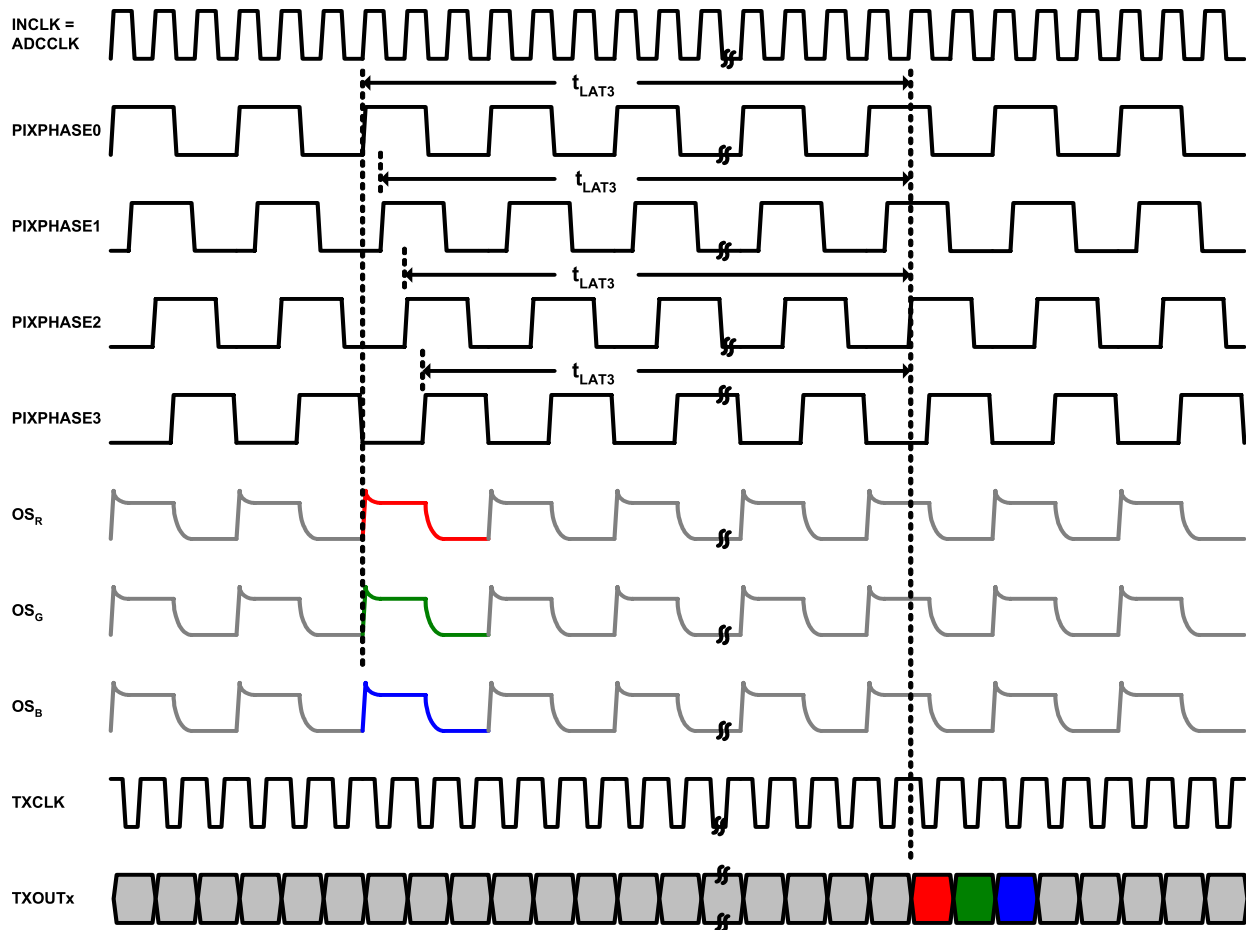

Data latency shown is for Mode 3 in relation to PIXPHASE0 with the processing order set to OS_R→OS_G→OS_B. If the incoming pixels are not aligned with PIXPHASE0, one of the remaining PIXPHASEs can be selected as the sampling phase without effecting the output data location.

Figure 45. Mode 3 LVDS Data Latency

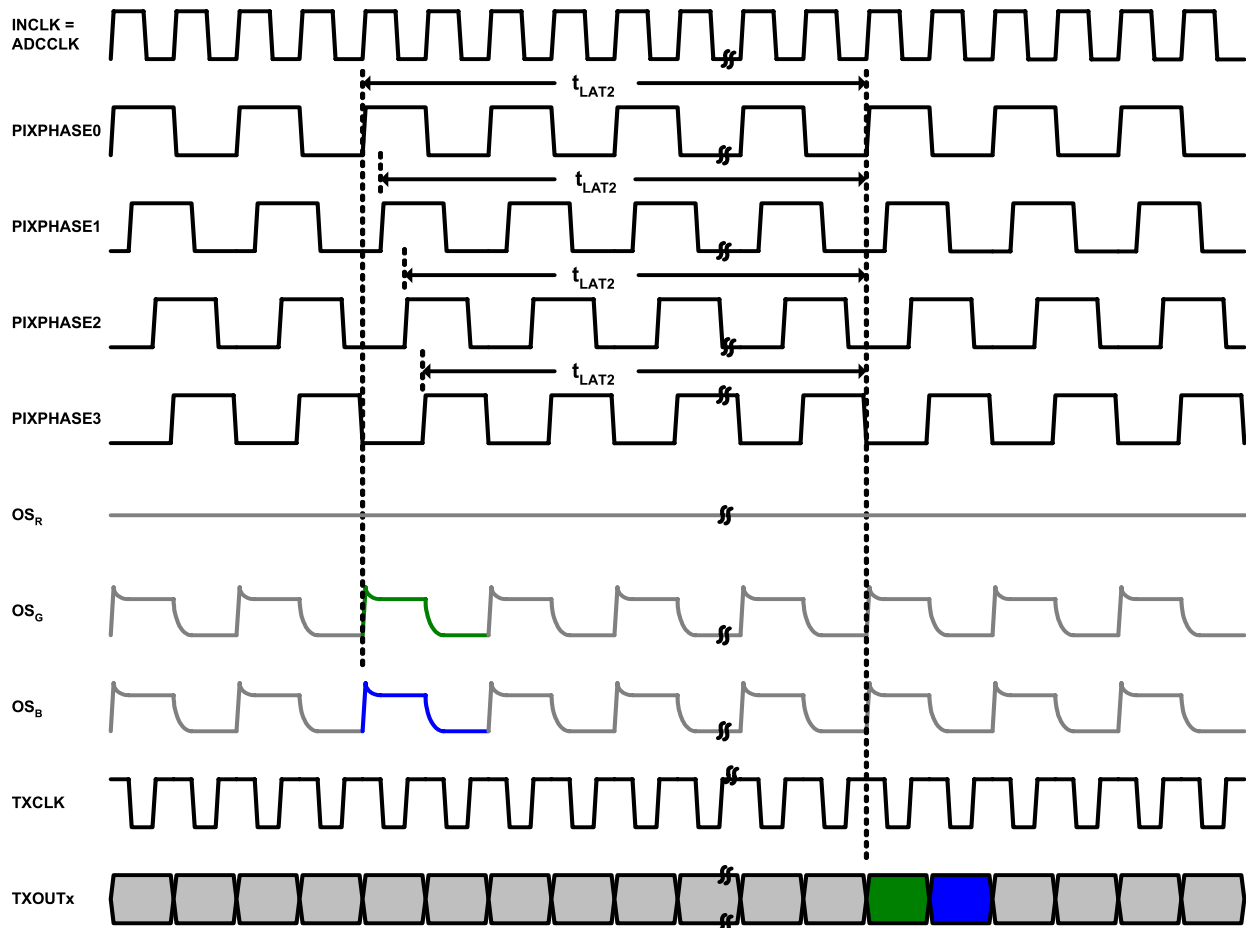

Data latency shown is for Mode 2 in relation to PIXPHASE0 with the processing order set to OS_g ⊕ OS_b. If the incoming pixels are not aligned with PIXPHASE0, one of the remaining PIXPHASEs can be selected as the sampling phase without effecting the output data location.

Figure 46. Mode 2 LVDS Data Latency

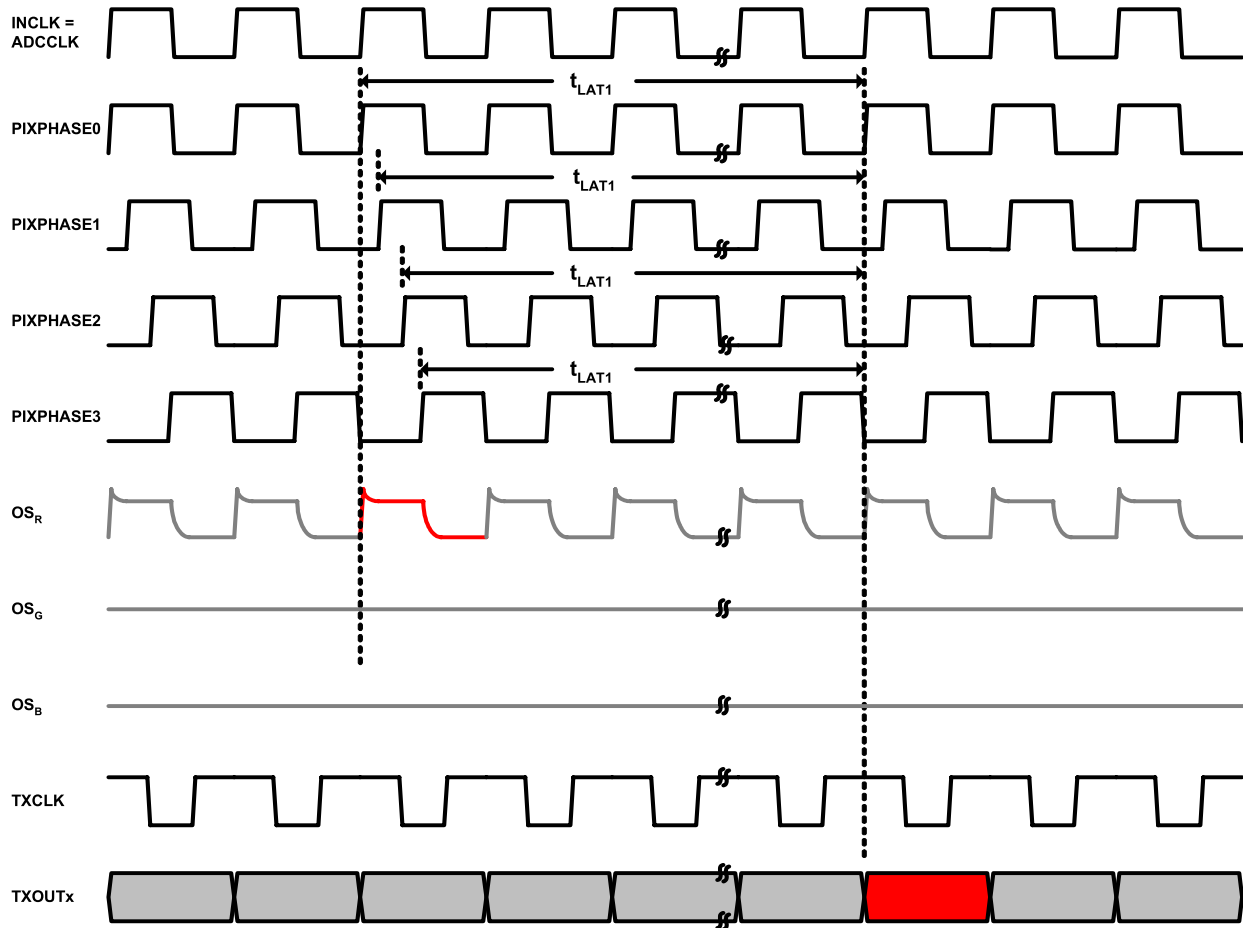

Data latency shown is for Mode 1 in relation to PIXPHASE0 with the processing channel configured to OS_R. If the incoming pixels are not aligned with PIXPHASE0, one of the remaining PIXPHASEs can be selected as the sampling phase without effecting the output data location.

Figure 47. Mode 1 LVDS Data Latency

7.3.9.5 LVDS Test Modes

The LVDS test modes present several different data patterns to the input of the LVDS serializer block. All 21 bits are used and there is no control bit coding present. The SH signal resets the LVDS test pattern and the pattern will resume only after SH is deasserted. If no SH signal is sent, the pattern continues indefinitely.

7.3.9.5.1 Test Mode 1 - Worst Case Transitions

This test mode provides an LVDS output with the maximum possible transitions. This mode is useful for system EMI evaluations, and for ATE timing tests.

The effective data values are an alternating pattern between 21'b101010101010101010101 (0x155555) and 21'b010101010101010101010 (0x0AAAAA). This test pattern resets to 0x155555 after the SH signal.

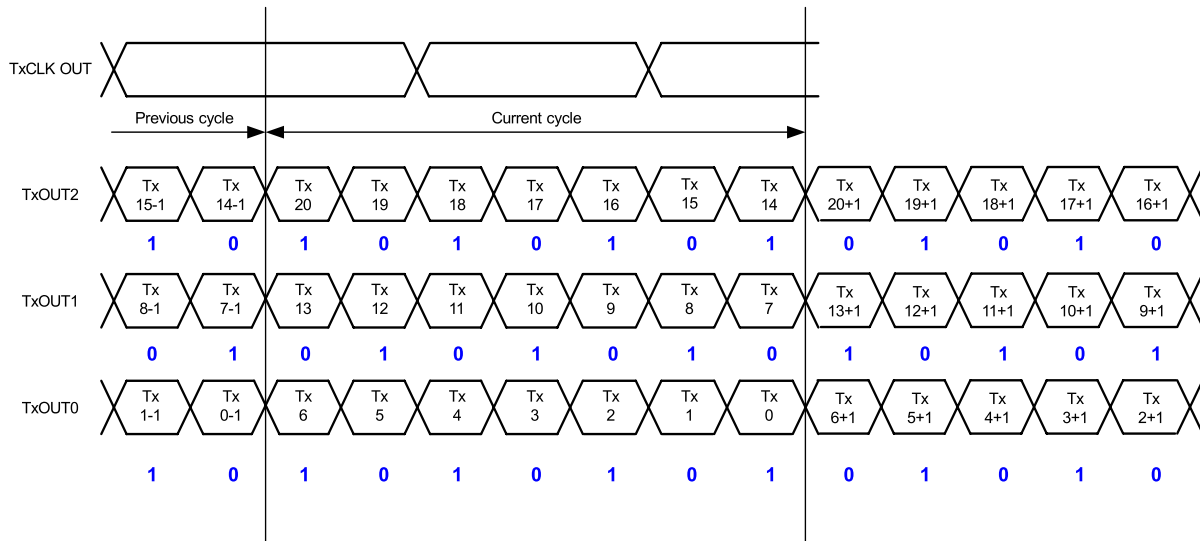

Figure 48. LVDS Test Pattern

7.3.9.5.2 Test Mode 2 - Ramp

This mode provides LVDS data that progresses from 0x00000 to the full scale output 0x1FFFFFF incrementing by 1 per LVDS Clock. When the LVDS ramp test pattern is selected, the ramp begins immediately and counts from zero to the full scale value, and then repeats.

7.3.9.5.3 Test Mode 3 - Fixed Output Data

This mode allows a fixed data value to be output. The value is set via Upcounter Register 1, 2 and 3. The 21 bit value taken from these registers is repetitively sent out over the LVDS link. This is useful for system debugging of the LVDS link and receiver circuitry.

7.3.10 CMOS Output Mode

7.3.10.1 CMOS Output Data Format

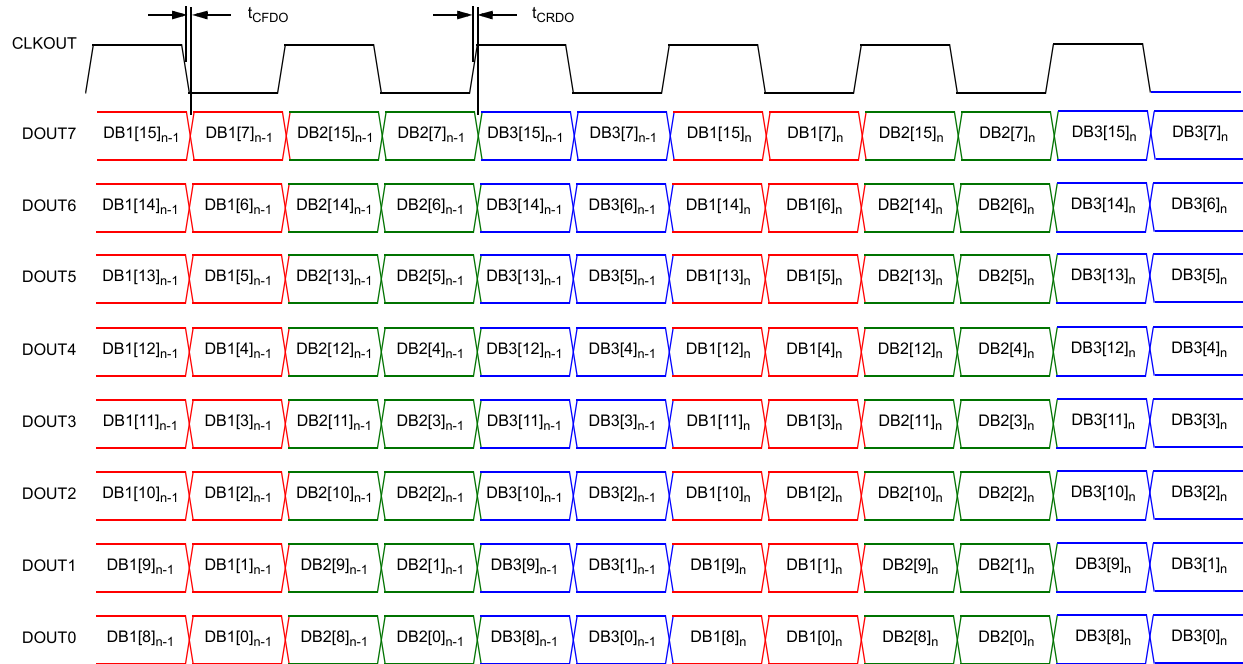
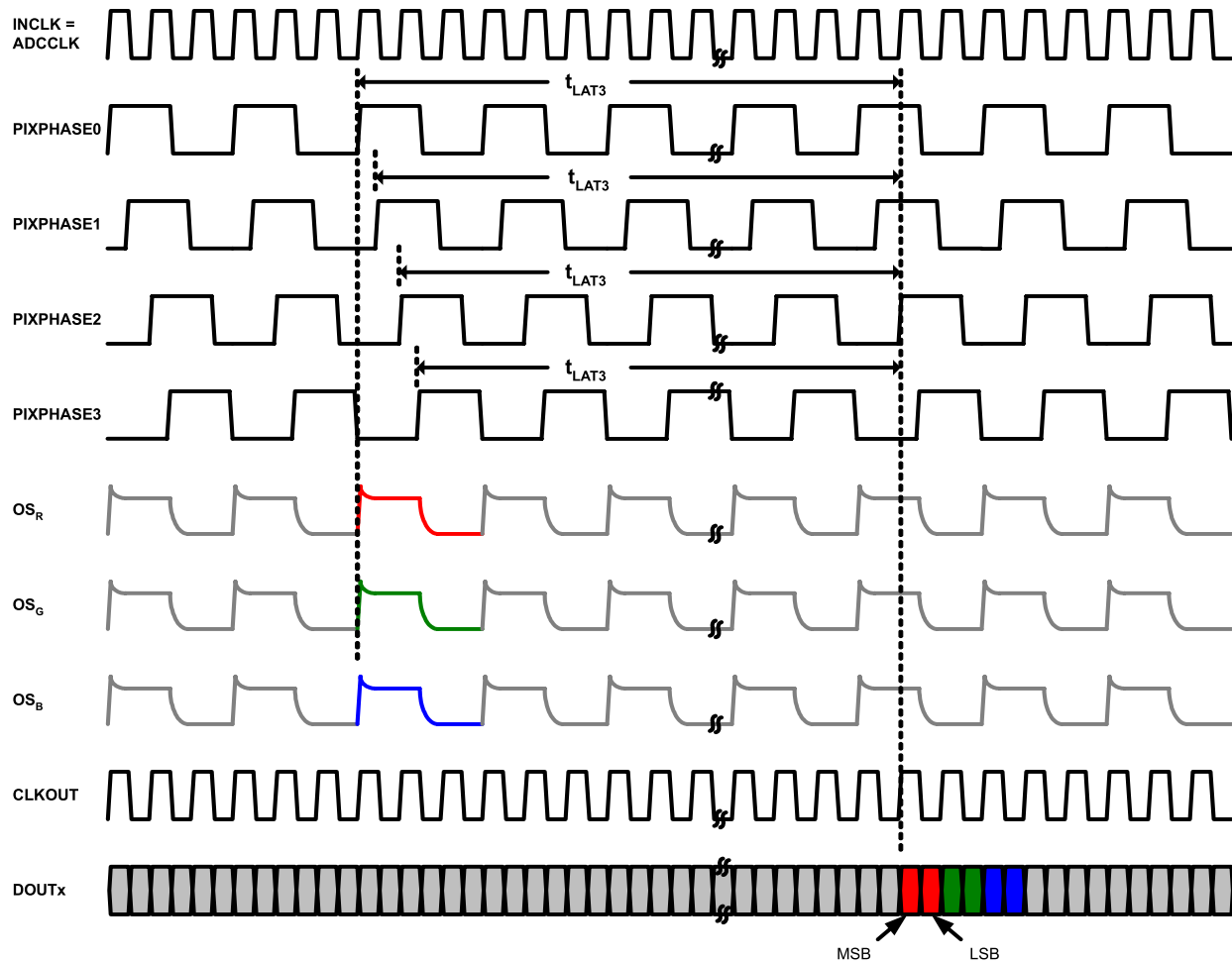

Figure 49. CMOS Data Output Format (Mode 3 Shown)

7.3.11 CMOS Output Data Latency Diagrams



Data latency shown is for Mode 3 in relation to PIXPHASE0 with the processing order set to $OS_R \rightarrow OS_G \rightarrow OS_B$. If the incoming pixels are not aligned with PIXPHASE0, one of the remaining PIXPHASEs can be selected as the sampling phase without effecting the output data location.

Figure 50. Mode 3 CMOS Output Latency

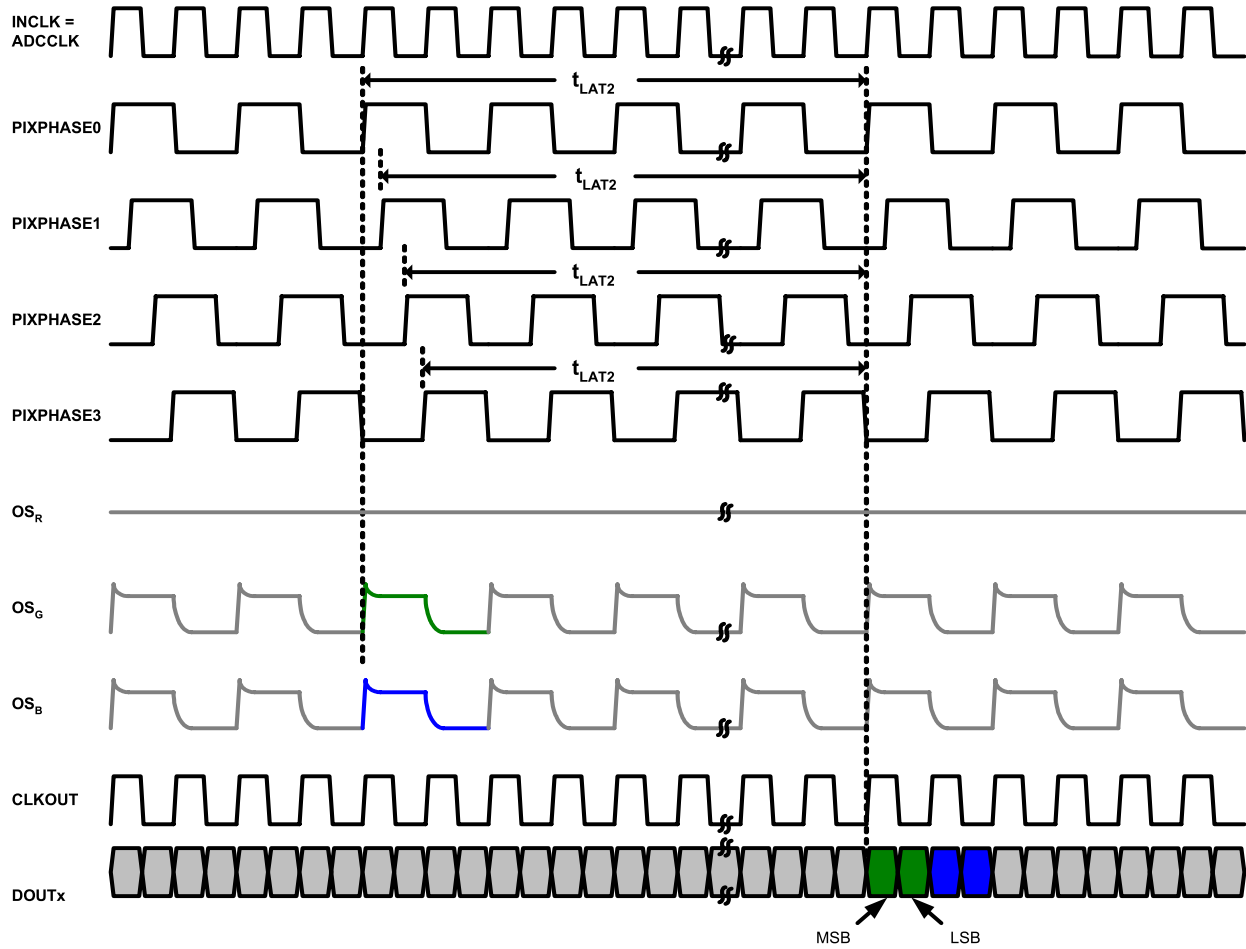

Data latency shown is for Mode 2 in relation to PIXPHASE0 with the processing order set to OS_G→OS_B. If the incoming pixels are not aligned with PIXPHASE0, one of the remaining PIXPHASEs can be selected as the sampling phase without effecting the output data location.

Figure 51. Mode 2 CMOS Output Latency

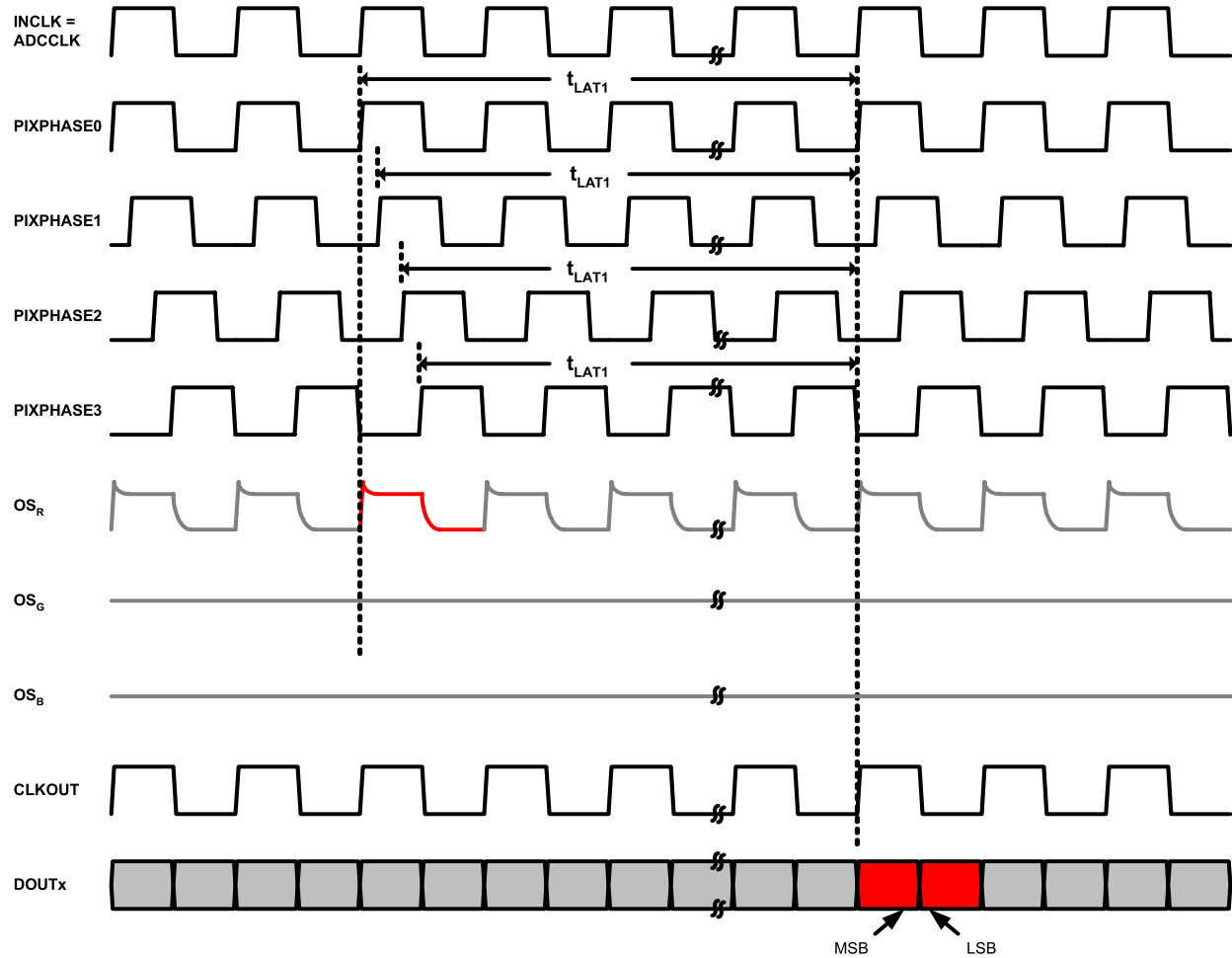

Data latency shown is for Mode 1 in relation to PIXPHASE0 with the processing channel configured to OS_R. If the incoming pixels are not aligned with PIXPHASE0, one of the remaining PIXPHASEs can be selected as the sampling phase without effecting the output data location.

Figure 52. Mode 1 CMOS Output Latency

7.4 Device Functional Modes

Table 6 lists the register settings for the modes of operation.

Table 6. Modes Of Operation Register Settings Table

Operating Mode	Sampling Input	Signal Path	Output Sequencing Mode 3 and 2 = Pixel Seq Mode 1 = Color Line Seq	Main Config.	Main Config. Register 0							
				Reg. 3	Mode		Color		Order	Color Seq. Length		
				Bit [3]	Bit[7]	Bit[6]	Bit[5]	Bit[4]	Bit[3]	Bit[2]	Bit[1]	Bit[0]
Mode3-RGB Forward	OS _R OS _G OS _B	RGB	Pixel _R →Pixel _G →Pixel _B →	x	1	1	1	1	0	0	0	1
Mode3-RGB Reverse	OS _R OS _G OS _B	RGB	Pixel _B →Pixel _G →Pixel _R →	x	1	1	1	1	1	0	0	1
Mode2-RG Forw.	OS _R OS _G	RG	Pixel _R →Pixel _G →	x	1	0	0	0	0	0	0	1
Mode2-RG Rev.	OS _R OS _G	RG	Pixel _G →Pixel _R →	x	1	0	0	0	1	0	0	1
Mode2-GB Forw.	OS _G OS _B	GB	Pixel _G →Pixel _B →	x	1	0	0	1	0	0	0	1
Mode2-GB Rev.	OS _G OS _B	GB	Pixel _B →Pixel _G →	x	1	0	0	1	1	0	0	1
Mode2-RB Forw.	OS _R OS _B	RB	Pixel _R →Pixel _B →	x	1	0	1	0	0	0	0	1
Mode2-RB Rev.	OS _R OS _B	RB	Pixel _B →Pixel _R →	x	1	0	1	0	1	0	0	1
Mode1-R Mono	OS _R	R	Color Line Seq: 1→1→1→1→1→	x	0	1	0	0	0	0	0	1
Mode1a-R 2 Color For.	OS _R	R	Color Line Seq: 1→2→1→2→1→	0	0	1	0	0	0	0	1	0
Mode1a-R 2 Color Rev	OS _R	R	Color Line Seq: 2→1→2→1→2→	0	0	1	0	0	1	0	1	0
Mode1a-R 3 Color For.	OS _R	R	Color Line Seq: 1→2→3→1→2→	0	0	1	0	0	0	0	1	1
Mode1a-R 3 Color Rev	OS _R	R	Color Line Seq: 3→2→1→3→2→	0	0	1	0	0	1	0	1	1
Mode1a-R 4 Color For.	OS _R	R	Color Line Seq: 1→2→3→4→1→	0	0	1	0	0	0	1	0	0
Mode1a-R 4 Color Rev	OS _R	R	Color Line Seq: 4→3→2→1→4→	0	0	1	0	0	1	1	0	0
Mode1a-R 5 Color For.	OS _R	R	Color Line Seq: 1→2→3→4→5→	0	0	1	0	0	0	1	0	1
Mode1a-R 5 Color Rev	OS _R	R	Color Line Seq: 5→4→3→2→1→	0	0	1	0	0	1	1	0	1
Mode1a-G Mono	OS _G	G	Color Line Seq: 1→1→1→1→1→	1	0	1	0	1	0	0	0	1
Mode1a-B Mono	OS _B	B	Color Line Seq: 1→1→1→1→1→	1	0	1	1	0	0	0	0	1
Mode1b-RGB Forward	OS _R →OS _G →OS _B	RGB	Line _R →Line _G →Line _B →	1	0	0	1	1	0	x	x	x
Mode1b-RGB Reverse	OS _B →OS _G →OS _R	RGB	Line _R →Line _G →Line _B →	1	0	0	1	1	1	x	x	x

7.4.1 Mode 3 - Three Channel Input/Synchronous Pixel Sampling

In Mode 3, the OS_R, OS_G, and OS_B input channels are sampled synchronously. The sampled input signals are then processed in parallel through their respective channels with each channel offset and gain adjusted by their respective control registers. The signals are then routed through a 3-1 MUX to the ADC. The order in which pixels are processed through the MUX to the ADC is programmable (OS_R-OS_G-OS_B, or OS_B-OS_G-OS_R) and is synchronized by the SH pulse.

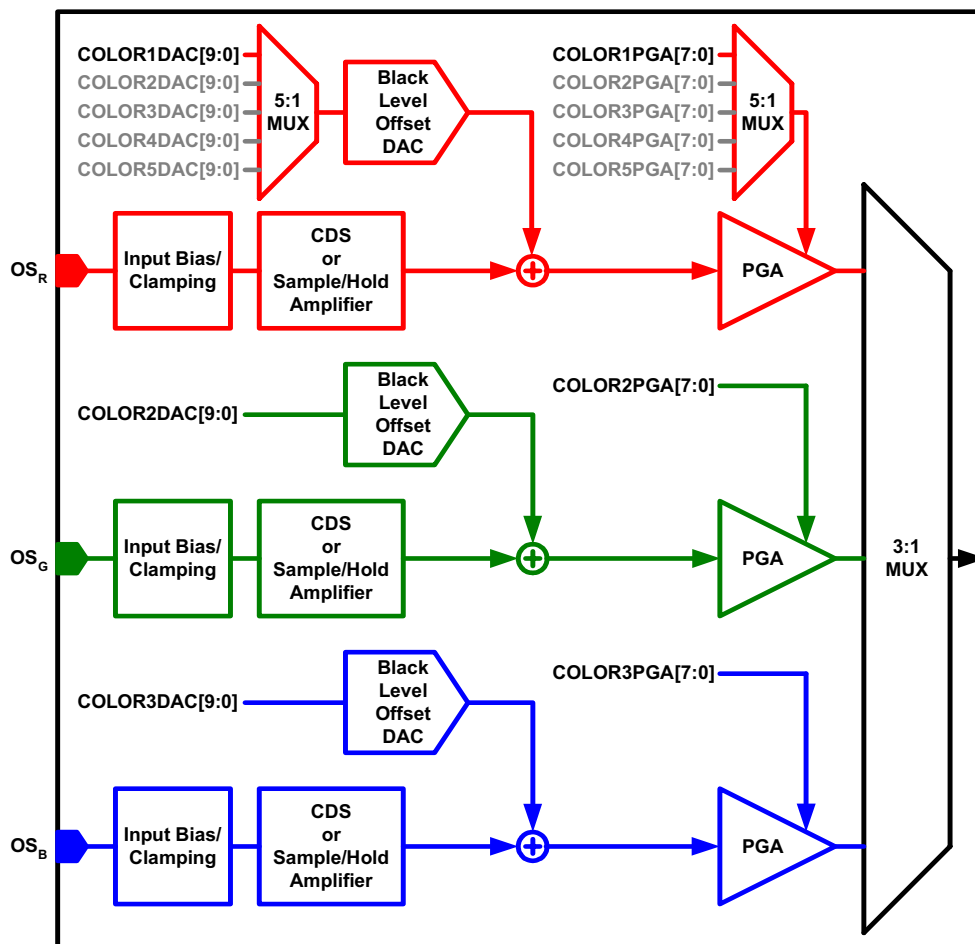

Figure 53. Synchronous Three Channel Pixel Mode Signal Routing

Table 7. Mode 3 Operating Details

			Detail
Channels Active	OS _B & OS _G & OS _R		3 channel synchronous pixel sampling.
Channel Sample Rate	15		MSPS per Channel (max)
ADC Sample Rate		45	MSPS (max)
f _{ADC} : f _{INCLK}	Internal 3x Clock Selected	3:01	f _{INCLK} = 15 MHz (max)
	Internal 1x Clock Selected	1:01	f _{INCLK} = 45 MHz (max)
Output Sequencing	SH Signal --> R-G-B-R-G-B-R-G-B-> or SH Signal --> B-G-R-B-G-R-B-G-R->		

7.4.2 Mode 2 - Two Channel Input/Synchronous Pixel Sampling

Mode 2 is useful for CCD sensors with a Black and White line with Even and Odd pixels. In its default configuration, Mode 2 samples Even sensor pixels via the Blue Channel Input, and Odd sensor pixels via the Green Channel Input. The selection of Even/Odd inputs can be changed through the serial interface registers. Sampling of the Even and Odd inputs is performed synchronously.

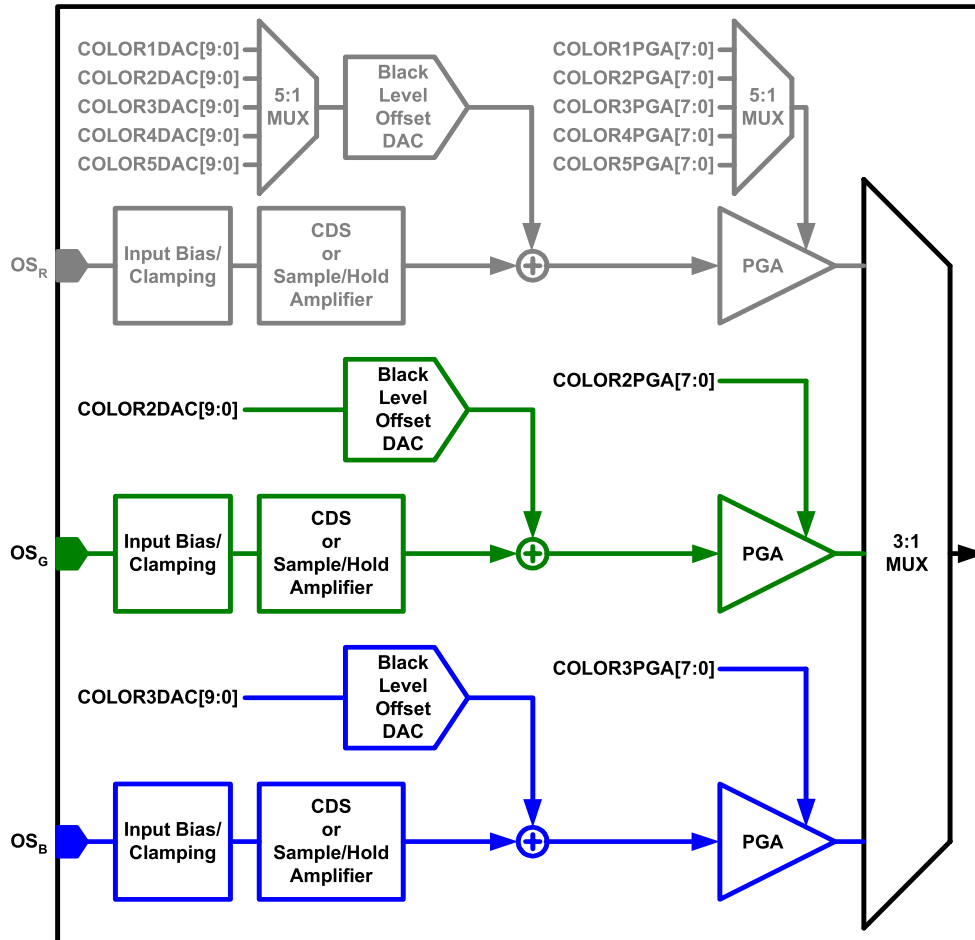

Active inputs shown as OS_G and OS_B. Active inputs can also be configured to OS_R/OS_G or OS_R/OS_B.

Figure 54. Mode 2 Signal Routing

Table 8. Mode 2 Operating Details

		Detail	
Channels Active	OS _G and OS _B (Default) or OS _R and OS _G or OS _B and OS _R	Two inputs synchronously processed as Even and Odd Pixels. Channel inputs are configurable.	
Channel Sample Rate	22.5	MSPS per Channel (max)	
ADC Sample Rate	45	MSPS (max)	
f _{ADC} : f _{INCLK}	Internal 2x Clock Selected	2:01	f _{INCLK} = 22.5 MHz (max)
	Internal 1x Clock Selected	1:01	f _{INCLK} = 45 MHz (max)
Output Sequencing	SH Signal --> Even-Odd-Even-Odd-Even-Odd-Even-> or SH Signal --> Odd-Even-Odd-Even-Odd-Even-Odd->		

7.4.3 Mode 1a - One Channel Input/One, Two, Three, Four, Or Five Color Sequential Line Sampling

In Mode 1a, all pixels are processed through a single input (OS_R , OS_G , or OS_B) chosen through the control register setup. This mode is useful in applications where only one input channel is used. The selected input is programmable through the control register. If more than one color is being sent to the input, the user can configure the OS_R channel to utilize up to five offset and gain coefficients for up to five different lines of color pixels. The SH pulse at the beginning of each line sequences the DAC and PGA coefficients as configured in the control registers. In this mode, the maximum channel speed is 30MSPS per channel with the ADC running at 30MSPS.

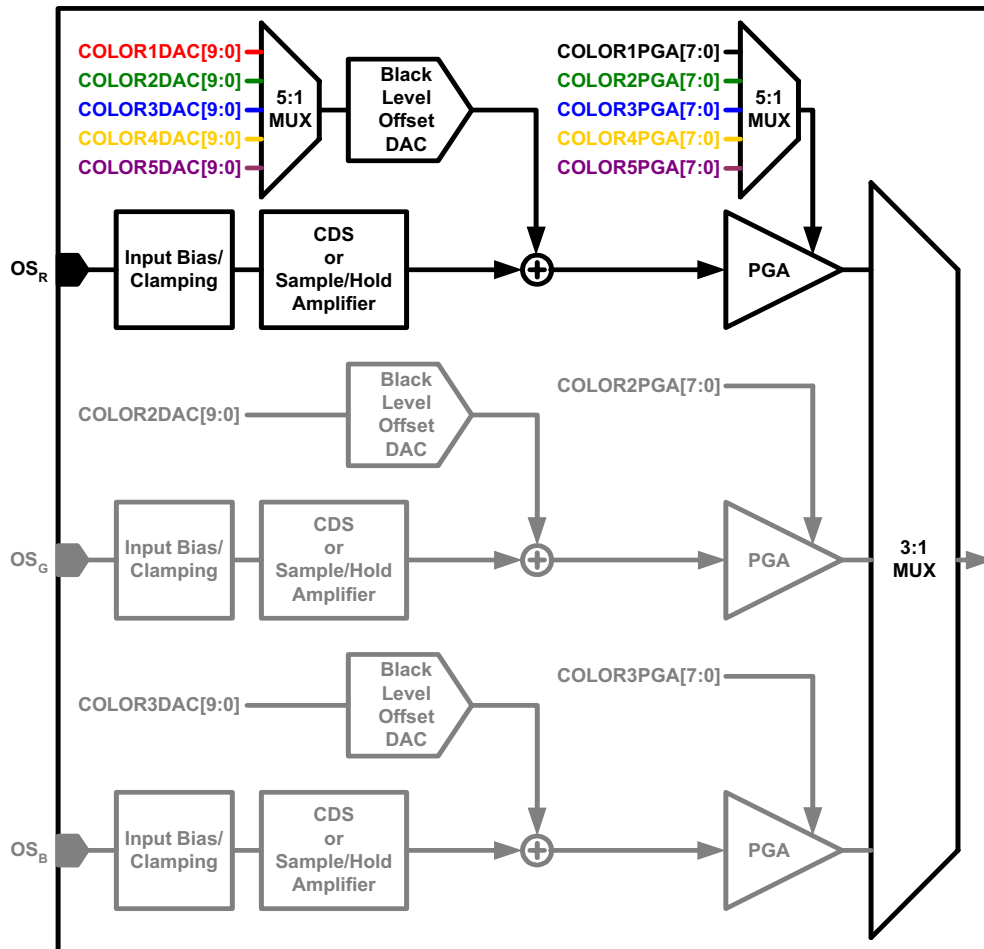

Up to “Five Color” line sequences shown thru OS_R input. “Single Color” sequences also selectable thru the OS_G and OS_B inputs.

Figure 55. Mode 1a Signal Routing

Table 9. Mode 1a Operating Details

			Detail
Channels Active	OS_R		One color active per line.
Channel Sample Rate	30		MSPS per Channel (max)
ADC Sample Rate		30	MSPS (max)
$f_{ADC}: f_{INCLK}$	Internal 1x Clock Selected	1:01	$f_{INCLK} = 30\text{MHz}$ (max)

Table 9. Mode 1a Operating Details (continued)

	Detail
Output Sequencing	SH Signal → Color 1→Color 1→Color 1→Color 1→Color 1→ →SH Signal → Color 2→Color 2→Color 2→Color 2→Color 2→ →SH Signal → Color 3→Color 3→Color 3→Color 3→Color 3→ →SH Signal → Color 4→Color 4→Color 4→Color 4→Color 4→ →SH Signal → Color 5→Color 5→Color 5→Color 5→Color 5→ or SH Signal → Color 5→Color 5→Color 5→Color 5→Color 5→ →SH Signal → Color 4→Color 4→Color 4→Color 4→Color 4→ →SH Signal → Color 3→Color 3→Color 3→Color 3→Color 3→ →SH Signal → Color 2→Color 2→Color 2→Color 2→Color 2→ →SH Signal → Color 1→Color 1→Color 1→Color 1→Color 1→

7.4.4 Mode 1b - One Channel Color Input Per Line/Sequential Line (Input) Sampling/Three Channel Processing

In Mode 1b, the OS_R , OS_G , and OS_B inputs are sampled sequentially and processed through their respective channels. This mode allows an entire line of Red, Green, or Blue Pixels to be sampled before sequencing to the next input. This mode is useful with sensors that output whole lines of pixels of a single color. The order in which the channels are sampled is fully programmable. Actual switching from channel to channel is triggered by an SH pulse. The first SH pulse after this mode is set (or reset) sets up the first programmed channel for gain and offset and initiates sampling through that channel alone. The next SH pulse switches the active channel to the second channel indicated by the configuration registers. This sequencing with SH pulses continues to the third channel and then continuously loops through the channels.

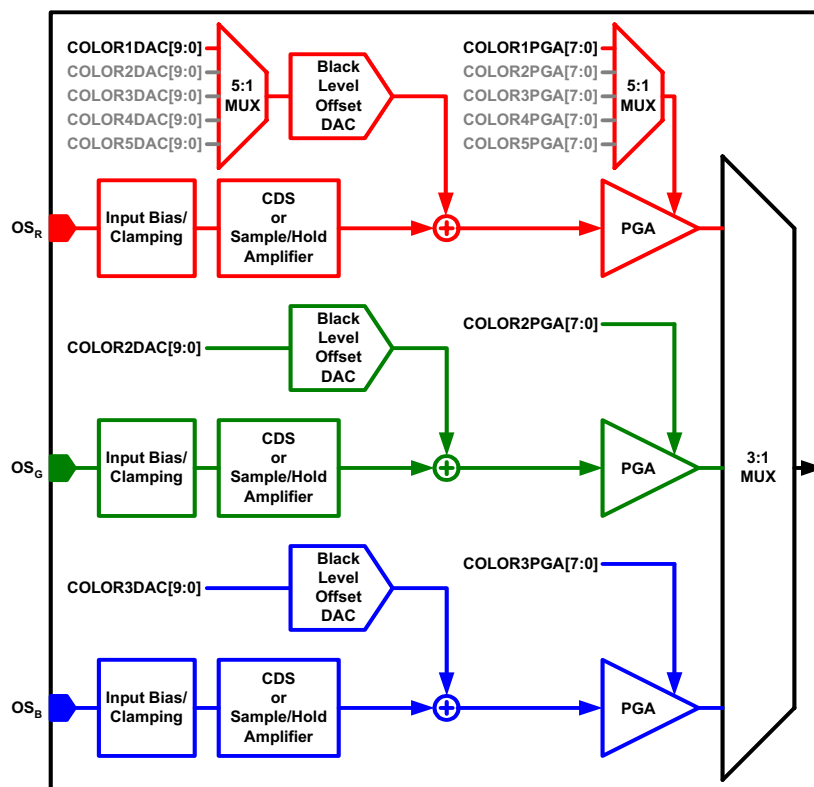

Figure 56. Mode 1b Signal Routing

Table 10. Mode 1b Operating Details

			Detail
Channels Active	OS_B or OS_G or OS_R		One channel active per line. Active channel is sequenced by SH pulse at start of new line.
Channel Sample Rate	30		MSPS per Channel (max)
ADC Sample Rate		30	MSPS (max)
f_{ADC} : f_{INCLK}	Internal 1x Clock Selected	1:01	$f_{INCLK} = 30\text{MHz}$ (max)
Output Sequencing	SH Signal → R-R-R-R-R-R-R-R-R-R-R-R-R-R-R-R→ →SH Signal → G-G-G-G-G-G-G-G-G-G-G-G-G-G-G-G→ →SH Signal → B-B-B-B-B-B-B-B-B-B-B-B-B-B-B-B→ or SH Signal → B-B-B-B-B-B-B-B-B-B-B-B-B-B-B-B→ →SH Signal → G-G-G-G-G-G-G-G-G-G-G-G-G-G-G-G→ →SH Signal → R-R-R-R-R-R-R-R-R-R-R-R-R-R-R-R→		

7.5 Programming

7.5.1 Serial Interface

A serial interface is used to write and read the configuration registers. The interface is a three wire interface using SCLK, SEN, and SDIO connections. The main input clock (INCLK) to the LM98714 must be active during all Serial Interface commands.

7.5.1.1 Writing To The Serial Registers

To write to the serial registers, the timing diagram shown in Figure 57 must be met. First, SEN is toggled low. The LM98714 assumes control of the SDIO pin during the first eight clocks of the command. During this period, data is clocked out of the device at the rising edge of SCLK. The eight bit value clocked out is the contents of the previously addressed register, regardless if the previous command was a read or a write. At the rising edge of ninth clock, the LM98714 releases control of the SDIO pin. At the falling edge of the ninth clock period, the master should assume control of the SDIO pin and begin issuing the new command. SDIO is clocked into the LM98714 at the rising edge of SCLK. The remaining bits are composed of the “write” command bit (a zero), two device address bits (zeros for the LM98714), five bit register address to be written, and the eight bit register value to be written. When SEN toggles high, the register is written to, and the LM98714 now functions with this new data.

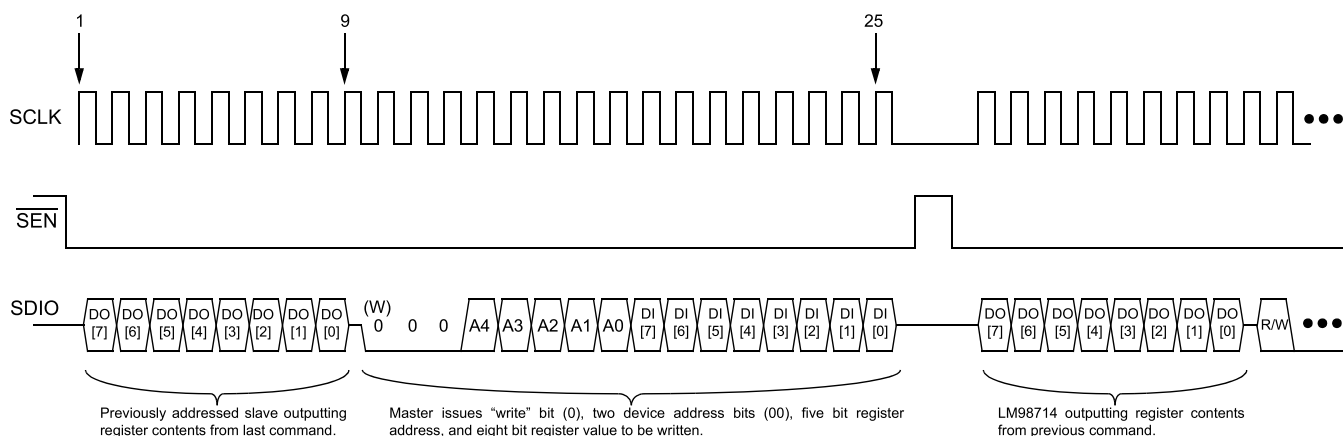

Figure 57. Serial Write

Programming (continued)

7.5.1.2 Reading The Serial Registers

To read to the serial registers, the timing diagram shown in Figure 58 must be met. First, SEN is toggled low. The LM98714 assumes control of the SDIO pin during the first eight clocks of the command. During this period, data is clocked out of the device at the rising edge of SCLK. The eight bit value clocked out is the contents of the previously addressed register, regardless if the previous command was a read or a write. At the rising edge of ninth clock, the LM98714 releases control of the SDIO pin. At the falling edge of the ninth clock period, the master should assume control of the SDIO pin and begin issuing the new command. SDIO is clocked into the LM98714 at the rising edge of SCLK. The remaining bits are composed of the “read” command bit (a one), two device address bits (zeros for the LM98714), five bit register address to be read, and the eight bit “don’t care” bits. When SEN toggles high, the register is not written to, but its contents are staged to be outputted at the beginning of the next command.

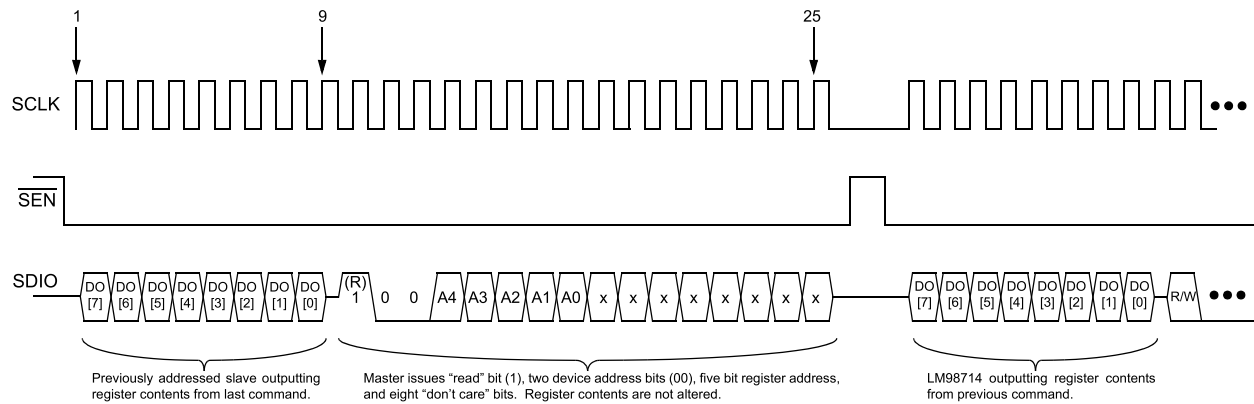

Figure 58. Serial Read

7.5.1.3 Serial Interface Timing Details

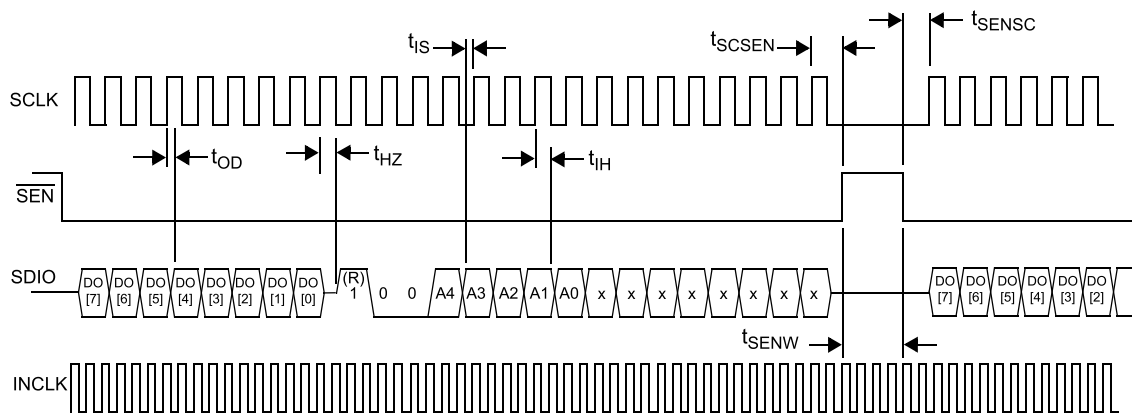

Figure 59. Serial Interface Specification Diagram

7.6 Register Maps

7.6.1 Configuration Registers

The LM98714 operation is very flexible to support a wide variety of sensors and system designs. This flexibility is controlled through configuration registers which are first summarized, then described in full in the following tables. Because the serial interface only allows 5 address bits, a register paging system is used to support the larger number of required registers.

A page register is present at the highest address (1Fh or 11111b). The power on default setting of the page register is 00. Writing other values to this register allows the other pages to be accessed. The page register is mirrored, and is accessible at the highest address on each page.

Figure 60 shows the proper sequence of operation for the LM98714.

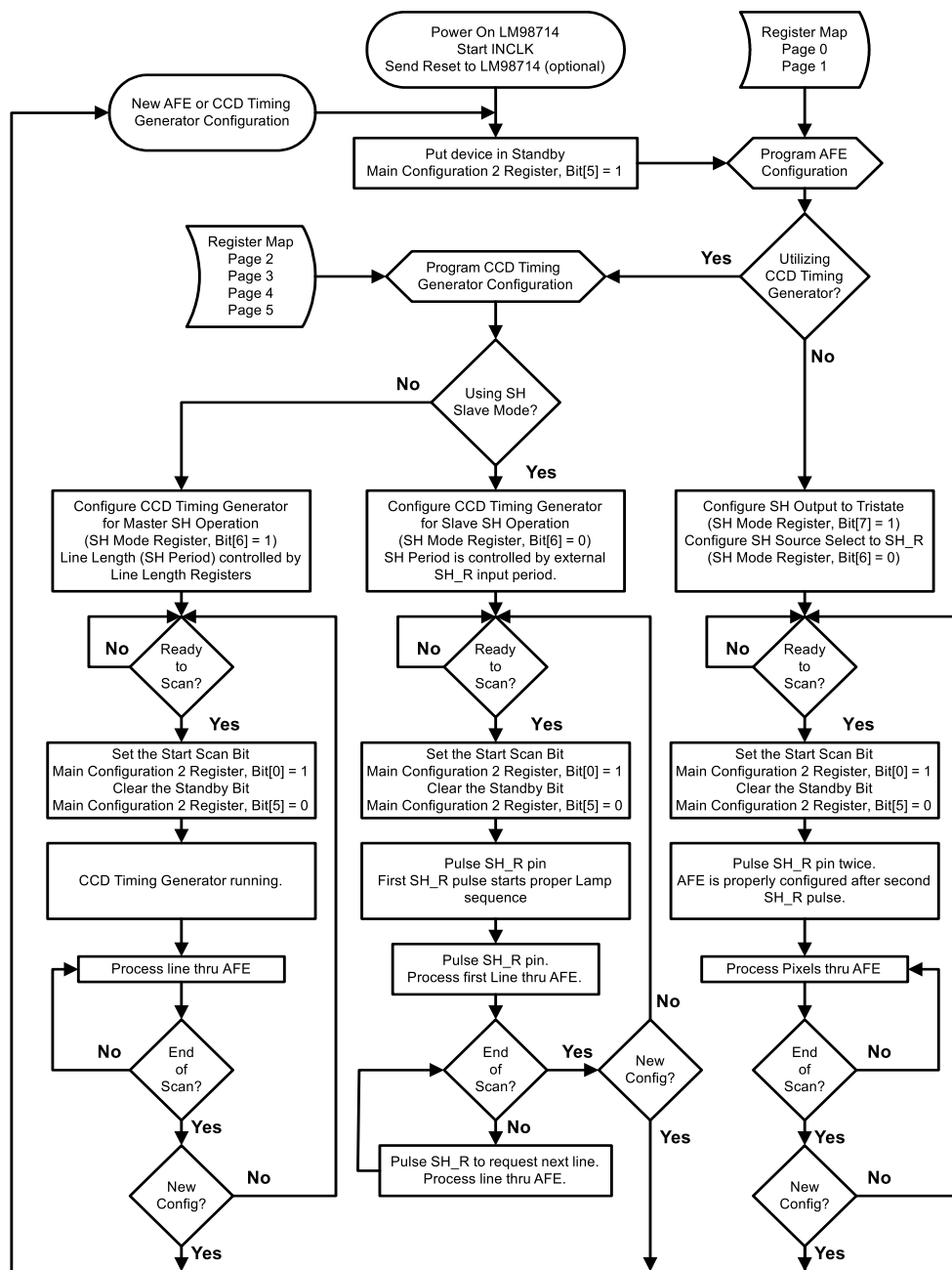

Figure 60. LM98714 Proper Sequence of Operation

Table 11. Page 0 Register Table - Main Analog Front End Configuration

Address (Binary)	Register Title (Mnemonic)	Default (Binary)	Register/Bit Description								
			Bit 7	Bit 6	Bit 5	Bit 4	Bit 3	Bit 2	Bit 1	Bit 0	
Note: The active register page is selected by writing the desired value to the page select register 1Fh. This register is mirrored on all register pages.											
Page 0	Page Register 1F = 0000 0000										
00000	Main Configuration 0	1111 0001	Operating Mode Select								
00001	Main Configuration 1	0101 0000	Source Follower Enable	Input Bias Enable	Input Polarity	Sampling Mode Select	Output Format	PIXCLK/ ADCCLK Config.	Pixel Phase Clock Select		
00010	Main Configuration 2	0000 0000	Not Used		Active/ Standby	Gain Mode Select	Output Enable	Power-down	Soft Reset	Start Scan	
00011	Main Configuration 3	0000 0111					Processing Channel Override	Reserved			
00100	Main Configuration 4	0000 0000	Not Used				Upcount Enable	LVDS Test Mode			
00101	Input Clamp Control	0000 0000	Not Used				Auto CLPIN Width		Auto CLPIN Enable	CLPIN Gating	
00110	Auto CLPIN Position	0010 0111	MSB							LSB	
00111	VCLP Configuration	0010 0000	Not Used		VCLP Reference Select		VCLP DAC Bits				
01000	Black Level Clamp Control	0000 0000	Line Averaging		Pixel Averaging		Offset Integration		BLKCLP Mode Select		
01001	Auto Black Level Clamp Position	0000 0000	Not Used	MSB						LSB	
01010	Target Black Level MSB	0010 0000	MSB							LSB+2	
01011	Target Black Level LSB	0000 0000	Not Used						LSB+1	LSB	
01100	OS _R CLAMP Control	0000 0000	Not Used			CLAMP _R Position					
01101	OS _G CLAMP Control	0000 0000	Not Used			CLAMP _G Position					
01110	OS _B CLAMP Control	0000 0000	Not Used			CLAMP _B Position					
01111	OS _R SAMPLE Control	0000 0000	Not Used	SAMPLE _R Position							
10000	OS _G SAMPLE Control	0000 0000	Not Used	SAMPLE _G Position							
10001	OS _B SAMPLE Control	0000 0000	Not Used	SAMPLE _B Position							
10010	Upcounter Register 1	0000 0000	Count Value LSBs								
10011	Upcounter Register 2	0000 0000	Count Value Middle 8 Bits								
10100	Upcounter Register 3	0000 0000	Not Used				Count Value MSBs				
10101											
10110											
10111											
11000											
11001											
11010											
11011											
11100											
11101											
11110		0000 0100									
11111	Page Register	0000 0000	Reserved (program all zeros)					LSB+2	LSB+1	LSB	

Table 12. Page 1 Register Table - Offset and Gain Settings

Address (Binary)	Register Title (Mnemonic)	Default (Binary)	Register/Bit Description								
			Bit 7	Bit 6	Bit 5	Bit 4	Bit 3	Bit 2	Bit 1	Bit 0	
Note: The active register page is selected by writing the desired value to the page select register 1Fh. This register is mirrored on all register pages.											
Page 1	Page Register 1F = 0000 0001										
00000	Color 1 PGA	0101 0100	MSB							LSB	
00001	Color 2 PGA	0101 0100	MSB							LSB	
00010	Color 3 PGA	0101 0100	MSB							LSB	
00011	Color 4 PGA	0101 0100	MSB							LSB	
00100	Color 5 PGA	0101 0100	MSB							LSB	
00101	Color 1 Black Level Offset DAC MSB	1000 0000	MSB							LSB+2	
00110	Color 1 Black Level Offset DAC LSB	0000 0000	Not Used							LSB+1	LSB
00111	Color 2 Black Level Offset DAC MSB	1000 0000	MSB							LSB+2	
01000	Color 2 Black Level Offset DAC LSB	0000 0000	Not Used							LSB+1	LSB
01001	Color 3 Black Level Offset DAC MSB	1000 0000	MSB							LSB+2	
01010	Color 3 Black Level Offset DAC LSB	0000 0000	Not Used							LSB+1	LSB
01011	Color 4 Black Level Offset DAC MSB	1000 0000	MSB							LSB+2	
01100	Color 4 Black Level Offset DAC LSB	0000 0000	Not Used							LSB+1	LSB
01101	Color 5 Black Level Offset DAC MSB	1000 0000	MSB							LSB+2	
01110	Color 5 Black Level Offset DAC LSB	0000 0000	Not Used							LSB+1	LSB
01111	Color 1 Digital Offset	0100 0000	Not Used	MSB						LSB	
10000	Color 2 Digital Offset	0100 0000	Not Used	MSB						LSB	
10001	Color 3 Digital Offset	0100 0000	Not Used	MSB						LSB	
10010	Color 4 Digital Offset	0100 0000	Not Used	MSB						LSB	
10011	Color 5 Digital Offset	0100 0000	Not Used	MSB						LSB	
10100											
10101											
10110											
10111											
11000											
11001											
11010											
11011											
11100											
11101											
11110		0000 0100									
11111	Page Register	0000 0000	Reserved (program all zeros)						LSB+2	LSB+1	LSB

Table 13. Page 2 Register Table - CCD/CIS Timing Generator Control 1

Address (Binary)	RegisterTitle (Mnemonic)	Default (Binary)	Register/Bit Description							
			Bit 7	Bit 6	Bit 5	Bit 4	Bit 3	Bit 2	Bit 1	Bit 0
Note: The active register page is selected by writing the desired value to the page select register 1Fh. This register is mirrored on all register pages.										
Page 2	Page Register 1F = 0000 0010									
00000	SH Mode	0000 0000	SH Output Enable	SH Source Select	SH Mode			SH Delay		
00001	SH Pulse Width	0010 0111	SH Pulse Width							
00010	PIX1/2 Control	1100 1000	PIX1 Activity	PIX1 Polarity	PIX1 Frequency	PIX1 Activity During SH	PIX2 Activity	PIX2 Polarity	PIX2 Frequency	PIX2 Activity During SH
00011	PIX3/4 Control	1000 1000	PIX3 Activity	PIX3 Polarity	PIX3 Frequency	PIX3 Activity During SH	PIX4 Activity	PIX4 Polarity	PIX4 Frequency	PIX4 Activity During SH
00100	PIX5/6 Control	0000 0000	PIX5 Activity	PIX5 Polarity	PIX5 Frequency	PIX5 Activity During SH	PIX6 Activity	PIX6 Polarity	PIX6 Frequency	PIX6 Activity During SH
00101	PIX7/8 Control	0000 0000	PIX7 Activity	PIX7 Polarity	PIX7 Frequency	PIX7 Activity During SH	PIX8 Activity	PIX8 Polarity	PIX8 Frequency	PIX8 Activity During SH
00110	Line Clamp Enable	0000 0000	PIX8 Line Clamp Enable	PIX7 Line Clamp Enable	PIX6 Line Clamp Enable	PIX5 Line Clamp Enable	PIX4 Line Clamp Enable	PIX3 Line Clamp Enable	PIX2 Line Clamp Enable	PIX1 Line Clamp Enable
00111	PIX1 Start	0000 0000	Reserved	MSB						LSB
01000	PIX1 End	0001 0101	Reserved	MSB						LSB
01001										
01010	PIX2 Start	0000 0000	Reserved	MSB						LSB
01011	PIX2 End	0001 0101	Reserved	MSB						LSB
01100										
01101	PIX3 Start	0000 1011	Reserved	MSB						LSB
01110	PIX3 End	0000 1101	Reserved	MSB						LSB
01111										
10000	PIX4 Start	0001 0000	Reserved	MSB						LSB
10001	PIX4 End	0001 0011	Reserved	MSB						LSB
10010										
10011	PIX5 Start	0000 0000	Reserved	MSB						LSB
10100	PIX5 End	0000 0000	Reserved	MSB						LSB
10101										
10110	PIX6 Start	0000 0000	Reserved	MSB						LSB
10111	PIX6 End	0000 0000	Reserved	MSB						LSB
11000										
11001	PIX7 Start	0000 0000	Reserved	MSB						LSB
11010	PIX7 End	0000 0000	Reserved	MSB						LSB
11011										
11100	PIX8 Start	0000 0000	Reserved	MSB						LSB
11101	PIX8 End	0000 0000	Reserved	MSB						LSB
11110	CMOS Data Mode	0000 0000	Reserved		CLK10/ CLKOUT	CLK9/ CB[4]	CLK8/ CB[3]	CLK7/ CB[2]	CLK6/ CB[1]	CLK5/ CB[0]
	Status Bit Enable									
11111	Page Register	0000 0000	Reserved (program all zeros)					LSB+2	LSB+1	LSB

Table 14. Page 3 Register Table - CCD/CIS Timing Generator Control 2

Address (Binary)	Register Title (Mnemonic)	Default (Binary)	Register/Bit Description							
			Bit 7	Bit 6	Bit 5	Bit 4	Bit 3	Bit 2	Bit 1	Bit 0
Note: The active register page is selected by writing the desired value to the page select register 1Fh. This register is mirrored on all register pages.										
Page 3	Page Register 1F = 0000 0011									
00000	Output Mapping CLK1/CLK2	0000 0000	Output Mapping for CLK1 Pin				Output Mapping for CLK2 Pin			
00001	Output Mapping CLK3/CLK4	0000 0000	Output Mapping for CLK3 Pin				Output Mapping for CLK4 Pin			
00010	Output Mapping CLK5/CLK6	0000 0000	Output Mapping for CLK5 Pin				Output Mapping for CLK6 Pin			
00011	Output Mapping CLK7/CLK8	0000 0000	Output Mapping for CLK7 Pin				Output Mapping for CLK9 Pin			
00100	Output Mapping CLK9/(CLKOUT/ CLK10)	0000 0000	Output Mapping for CLK9 Pin				Output Mapping for CLKOUT/CLK10 Pin			
00101	Illumination Mode	0000 0000	LAMP _R Normal State	LAMP _G Normal State	LAMP _B Normal State	LampIR1 Normal State	LampIR2 Normal State	Reserved		SH/LAMP Overlap Enable
00110	Line 1 Lamp Selection	0000 0000				Red Lamp Enable	Green Lamp Enable	Blue Lamp Enable	IR1 Lamp Enable	IR2 Lamp Enable
00111	Line 2 Lamp Selection	0000 0000				Red Lamp Enable	Green Lamp Enable	Blue Lamp Enable	IR1 Lamp Enable	IR2 Lamp Enable
01000	Line 3 Lamp Selection	0000 0000				Red Lamp Enable	Green Lamp Enable	Blue Lamp Enable	IR1 Lamp Enable	IR2 Lamp Enable
01001	Line 4 Lamp Selection	0000 0000				Red Lamp Enable	Green Lamp Enable	Blue Lamp Enable	IR1 Lamp Enable	IR2 Lamp Enable
01010	Line 5 Lamp Selection	0000 0000				Red Lamp Enable	Green Lamp Enable	Blue Lamp Enable	IR1 Lamp Enable	IR2 Lamp Enable
01011	LAMP _R On - MSB	0000 0000	Reserved			SH_OR Enable	MSB			
01100	LAMP _R On - LSB	0001 0001						LSB		
01101	LAMP _R Off - MSB	0000 0011	Reserved				MSB			
01110	LAMP _R Off - LSB	0000 0110						LSB		
01111	LAMP _G On - MSB	0000 0000	Reserved			SH_OR Enable	MSB			
010000	LAMP _G On - LSB	0001 0010						LSB		
10001	LAMP _G Off - MSB	0000 0011	Reserved				MSB			
10010	LAMP _G Off - LSB	0000 0000						LSB		
10011	LAMP _B On - MSB	0000 0000	Reserved			SH_OR Enable	MSB			
10100	LAMP _B On - LSB	0001 0011						LSB		
10101	LAMP _B Off - MSB	0000 0011	Reserved				MSB			
10110	LAMP _B Off - LSB	0011 0000						LSB		
10111	LAMP _{IR1} On - MSB	0000 0000	Reserved			SH_OR Enable	MSB			
11000	LAMP _{IR1} On - LSB	0001 0100						LSB		
11001	LAMP _{IR1} Off - MSB	0000 0011	Reserved				MSB			
11010	LAMP _{IR1} Off - LSB	0011 0000						LSB		
11011	LAMP _{IR2} On - MSB	0000 0000	Reserved			SH_OR Enable	MSB			
11100	LAMP _{IR2} On - LSB	0001 0101						LSB		

Table 14. Page 3 Register Table - CCD/CIS Timing Generator Control 2 (continued)

Address (Binary)	Register Title (Mnemonic)	Default (Binary)	Register/Bit Description							
			Bit 7	Bit 6	Bit 5	Bit 4	Bit 3	Bit 2	Bit 1	Bit 0
11101	LAMP _{IR2} Off - MSB	0000 0011	Reserved				MSB			
11110	LAMP _{IR2} Off - LSB	0011 0000							LSB	
11111	Page Register	0000 0000	Reserved (program all zeros)				LSB+2	LSB+1	LSB	

Table 15. Page 4 Register Table - CCD/CIS Timing Generator Control 3

Address (Binary)	Register Title (Mnemonic)	Default (Binary)	Register/Bit Description							
			Bit 7	Bit 6	Bit 5	Bit 4	Bit 3	Bit 2	Bit 1	Bit 0
Note: The active register page is selected by writing the desired value to the page select register 1Fh. This register is mirrored on all register pages.										
Page 4	Page Register 1F = 0000 0100									
00000	Mode On - MSB	0000 0010	Reserved				MSB			
00001	Mode On - LSB	0000 0000							LSB	
00010	Mode Off - MSB	0000 0011	Reserved				MSB			
00011	Mode Off - LSB	0000 0001							LSB	
00100	Optical Black Pixels Start	0000 0000	MSB						LSB	
00101	Optical Black Pixels End	0000 0000	MSB						LSB	
00110	Start of Valid Pixels - MSB	0000 0000	Reserved		MSB					
00111	Start of Valid Pixels - LSB	0000 0001							LSB	
01000	End of Valid Pixels - MSB	0011 1111	Reserved		MSB					
01001	End of Valid Pixels - LSB	1111 1110							LSB	
01010	Line End - MSB	0011 1111	Reserved		MSB					
01011	Line End - LSB	1111 1111							LSB	
01100	Sample Timing Monitor 1	1111 1111								
01101	Sample Timing Monitor 2	1111 1111								
01110	Sample Timing Monitor 3	1111 1111								
01111	SH2/SH3 Control	0000 0000					SH3 Select	SH2 Select		
10000	PIX OR/NOR Control 1	0000 0000								
10001	PIX OR/NOR Control 2	0000 0000								
11111	Page Register	0000 0000	Reserved (program all zeros)					LSB+2	LSB+1	LSB

Table 16. Page 5 Register Table - CCD/CIS Timing Generator Control 4

Address (Binary)	Register Title (Mnemonic)	Default (Binary)	Register/Bit Description								
			Bit 7	Bit 6	Bit 5	Bit 4	Bit 3	Bit 2	Bit 1	Bit 0	
Note: The active register page is selected by writing the desired value to the page select register 1Fh. This register is mirrored on all register pages.											
Page 5	Page Register 1F = 0000 0101										
00000	PIX1/SH On Guardbands	0000 1111	PIX1 On Guardband								
00001	PIX1/SH Off Guardbands	0000 0111	PIX1 Off Guardband								
00010	PIX2/SH On Guardbands	0000 1111	PIX2 On Guardband								
00011	PIX2/SH Off Guardbands	0000 0111	PIX2 Off Guardband								
00100	PIX3/SH On Guardbands	0000 1111	PIX3 On Guardband								
00101	PIX3/SH Off Guardbands	0000 0111	PIX3 Off Guardband								
00110	PIX4/SH On Guardbands	0000 1111	PIX4 On Guardband								
00111	PIX4/SH Off Guardbands	0000 0111	PIX4 Off Guardband								
01000	PIX5/SH On Guardbands	0000 1111	PIX5 On Guardband								
01001	PIX5/SH Off Guardbands	0000 0111	PIX5 Off Guardband								
01010	PIX6/SH On Guardbands	0000 1111	PIX6 On Guardband								
01011	PIX6/SH Off Guardbands	0000 0111	PIX6 Off Guardband								
01100	PIX7/SH On Guardbands	0000 1111	PIX7 On Guardband								
01101	PIX7/SH Off Guardbands	0000 0111	PIX7 Off Guardband								
01110	PIX8/SH On Guardbands	0000 1111	PIX8 On Guardband								
01111	PIX8/SH Off Guardbands	0000 0111	PIX8 Off Guardband								
11111	Page Register	0000 0000	Reserved (program all zeros)				LSB+2	LSB+1	LSB		

7.6.2 Register Definition
Table 17. Register Descriptions

Page	Address (Binary)	Register Title	Default (Binary)	Bit No.	Description
Page 0 Registers					
0	0 0000	Main Configuration 0	1111 0001	[7:0]	Main Configuration Register 0
				[7:6]	Mode Select Bits.
					11 Mode 3 (Default) (3 Channel Mode)
					10 Mode 2 (2 Channel Mode)
				[7:6]	01 Mode 1a (1 Channel Mode, 1 Channel sampled for all lines)
					00 Mode 1b (3 Channel Line rate mode, 1 Channel sampled per line)
				[5:4]	Color Select Bits. Used to determine the inputs sampled during a scan.
					11 All three channels sampled (Default)
					10 Mode 2 = OS _R & OS _B Mode 1 = OS _B
					01 Mode 2 = OS _G & OS _B Mode 1 = OS _G
				[5:4]	00 Mode 2 = OS _R & OS _G Mode 1 = OS _R
					Color Order. Configures the sequence of the pixel processing.
				[3]	0 Forward (default)
					1 Reverse
				[2:0]	Color Sequence Length. Used in Mode 1a only to determine the number of lines of colors sequenced during a scan.
					111 Not valid
					110 Not Valid
101 Five color (line) sequence					
100 Four color (line) sequence					
011 Three color (line) sequence					
010 Two color (line) sequence					
001 One color (line) sequence (Default)					
000 Not Valid					

Table 17. Register Descriptions (continued)

Page	Address (Binary)	Register Title	Default (Binary)	Bit No.	Description
0	0 0001	Main Configuration 1	0101 0000	[7:0]	Main Configuration Register 1
				[7]	Source Follower Enable.
					0 Disable (Default) 1 Enable
				[6]	Input Bias Enable. Enables the Input Bias Resistor ladder.
					0 Disable 1 Enable (Default)
				[5]	Input Polarity. Configures the polarity mode of the input signal.
					0 Negative going input relative to reference (Default) 1 Positive going input relative to reference
				[4]	Sampling Mode Select.
					0 Sample and Hold Mode 1 Correlated Double Sampling Mode (Default)
					Output Format.
				[3]	0 LVDS (Default) 1 CMOS
					[2]
				Mode 3: ADC Frequency = 3x Pixel Frequency	
				Mode 2: ADC Frequency = 2x Pixel Frequency	
				Mode 1: ADC Frequency = 1x Pixel Frequency	
				0 ADCCLK User supplies ADC rate clock, LM98714 performs no multiplication 1 PIXCLK User supplies Pixel rate clock, LM98714 performs clock multiplication	
Mode 3: PIXCLK internally multiplied by 3 to get ADC clock Mode 2: PIXCLK internally multiplied by 2 to get ADC clock					
Mode 1: PIXCLK = ADCCLK. This bit is not used for Mode 1					
[1:0]	Pixel Phase Clock Select. Coarse adjustment for Pixel phase relative to INCLK. Useful in systems where Pixel inputs arrive with significant delay relative to INCLK.				
	00 PIXPHASE0. Pixel phase aligned with INCLK				
	01 PIXPHASE1. Pixel phase delayed by $(T_{ADC\ Clock} * 3/7)$				
	10 PIXPHASE2. Pixel phase delayed by $(T_{ADC\ Clock})$ 11 PIXPHASE3. Pixel phase delayed by $(T_{ADC\ Clock} * (1 + 3/7))$				
0	0 0010	Main Configuration 2	0000 0000	[7:0]	Main Configuration 2
				[7:6]	Not Used
				[5]	Active/Standby
				[4]	Gain Mode Select. Selects either a 1x or 2x gain mode in the CDS/Sample/Hold Block.
					0 1x Gain in the CDS/Sample/Hold Block (Default) 1 2x Gain in the CDS/Sample/Hold Block
				[3]	Output Enable. Enables the Data Output pins.
					0 Disabled (Default) 1 Enable
				[2]	Powerdown
					0 Device fully powered (Default) 1 Powerdown. Power down of major analog blocks
				[1]	Software Reset. Performs a system reset when set to a 1. Self clearing.
[0]	Start Scan (BOS)				
	0 Ready (Default) 1 Start Scan. Control bit is self clearing				
0	0 0011	Main Configuration 3	0000 0111	[7:0]	Main Configuration 3
				[7:4]	Not Used
				[3]	Processing Channel Override. Used in Mode 1 to determine the analog processing path for the selected inputs.
					0 Multiplex all selected inputs into the Red Channel analog path (Default) 1 Process each selected input through its respective analog path
				[2:0]	Reserved Set to 111

Table 17. Register Descriptions (continued)

Page	Address (Binary)	Register Title	Default (Binary)	Bit No.	Description
0	0 0100	Main Configuration 4	0000 0000	[7:0]	Main Configuration 4
				[7:4]	Not Used
				[3]	Upcount Enable
				[2:0]	LVDS Test Mode. Activates LVDS test pattern output (when in LVDS output mode only).
					000 Normal operation, no test pattern output (Default)
					001 Test pattern 1: Alternating pattern between 0x155555 and 0x0AAAAA
					010 Test pattern 2: If Upcount Enable Bit set, count from 21h000000 to 21h 1FFFFFF
					011 Test pattern 3. Output Static Count value found represented by the three Upcounter Registers found on page 0
					Reg 0x14 Bits[4:0] = Count Values 5 MSBs
Reg 0x13 Bits[7:0] = Count Values 8 Middle Bits					
Reg 0x12 Bits[7:0] = Count Values 8 LSBs					
0	0 0101	Input Clamp Control	0000 0000	[7:0]	Input Clamp Control (CLPIN) Configuration Register
				[7:4]	Reserved
				[3:2]	Auto CLPIN Width. Width in Pixels of the Auto generated CLPIN pulse.
					00 4 Pixels (Default)
					01 8 Pixels
					10 16 Pixels
				[1]	11 32 Pixels
					Auto CLPIN Enable.
					0 Auto CLPIN Disabled
					CLPIN Pulse generation Disabled (Default)
				[0]	1 Auto CLPIN
					CLPIN generated internally with a programmable delay from SH
0	0 0110	Auto CLPIN Position	0010 0111	[7:0]	Auto CLPIN Pulse Position Register
				[7:0]	Auto CLPIN Pulse Position. Number of pixels in which Auto CLPIN pulse is delayed, relative to the falling edge of SH.
0	0 0111	VCLP Configuration	0010 0000	[7:0]	VCLP Configuration Register
				[7:6]	Reserved
				[5:4]	VCLP Reference Select.
					00 External Bias (No Internal Connection to Ladder Resistors or DAC)
					01 Internal VCLP DAC connection only
					10 Internal Resistor Ladder connection only (Default)
				11 Reserved	
[3:0]	4 Bit nibble for VCLP Reference DAC value.				

Table 17. Register Descriptions (continued)

Page	Address (Binary)	Register Title	Default (Binary)	Bit No.	Description
0	0 1000	Black Level Clamp Control	0000 0000	[7:0]	Black Level Correction Circuitry Configuration Register
				[7:6]	Line Averaging. Number of Lines that the correction loop will run. Line Counter is reset during any write to this register. A line beginning is defined by the SH pulse.
					00 Infinite (Default)
					01 15 Lines
					10 31 Lines
				[5:4]	11 63 Lines
					Pixel Averaging. Number of Black Level Pixels averaged by the correction loop.
					00 4 Pixels
					01 8 Pixels
				[3:2]	10 16 Pixels
					11 32 Pixels
					Offset Integration.
					00 Divide by 8
				[1:0]	01 Divide by 16
					10 Divide by 32
11 Divide by 64					
BLKCLP Mode Select. If Auto Black Clamp pulse is enabled, Offset DAC registers are read only.					
[7]	00 Auto Black Clamp Circuitry Disabled (default)				
	01 Auto Black Clamp pulse delayed from falling edge of SH pulse				
	10 Auto Black Clamp pulse delayed from falling edge of CLPIN pulse				
	11 Reserved				
0	0 1001	Auto Black Level Clamp Position	0000 0000	[7]	Reserved
				[6:0]	Black Level Clamp Position. Number of pixels in which Auto Black pulse is delayed, relative to selected trigger source.
0	0 1010	Target Black Level MSB	0010 0000	[7:0]	The 8 MSBs of the 10 Bit target output code for black pixels when using the Auto Black Level Correction loop.
0	0 1011	Target Black Level LSB	0000 0000	[7:0]	The target output code for black pixels when using the Auto Black Level Correction loop
				[7:2]	Reserved
				[1:0]	The 2 LSBs of the 10 Bit target output code for black pixels when using the Auto Black Level Correction loop.
0	0 1100	OS _R CLAMP Control	0000 0000	[7:5]	Not Used
				[4:0]	CLAMP _R Position. A value of 0 will force the position of this pulse to be at the mode dependant default.
0	0 1101	OS _G CLAMP Control	0000 0000	[7:5]	Not Used
				[4:0]	CLAMP _G Position. A value of 0 will force the position of this pulse to be at the mode dependant default.
0	0 1110	OS _B CLAMP Control	0000 0000	[7:5]	Not Used
				[4:0]	CLAMP _B Position. A value of 0 will force the position of this pulse to be at the mode dependant default.
0	0 1111	OS R SAMPLE Control	0000 0000	[7]	Not Used
				[6:0]	SAMPLE _R Position. A value of 0 will force the position of this pulse to be at the mode dependant default.
0	1 0000	OS _G SAMPLE Control	0000 0000	[7]	Not Used
				[6:0]	SAMPLE _G Position. A value of 0 will force the position of this pulse to be at its mode dependant default.
0	1 0001	OS _B SAMPLE Control	0000 0000	[7]	Not Used
				[6:0]	SAMPLE _B Position. A value of 0 will force the position of this pulse to be at its mode dependant default.
0	1 1111	Page Register	0000 0000	[7:0]	Used to select desired page of registers being accessed.
Page 1 Registers					
1	0 0000	Color 1 PGA	0101 0100	[7:0]	The eight bit byte selected by the 5:1 PGA MUX in Mode 1a during Color 1 lines. In Mode 1b, Mode 2 or Mode 3, the register used to define the PGA setting for the OS _R input.
1	0 0001	Color 2 PGA	0101 0100	[7:0]	The eight bit byte selected by the 5:1 PGA MUX in Mode 1a during Color 2 lines. In Mode 1b, Mode 2 or Mode 3, the register used to define the PGA setting for the OS _G input.
1	0 0010	Color 3 PGA	0101 0100	[7:0]	The eight bit byte selected by the 5:1 PGA MUX in Mode 1a during Color 3 lines. In Mode 1b, Mode 2 or Mode 3, the register used to define the PGA setting for the OS _B input.

Table 17. Register Descriptions (continued)

Page	Address (Binary)	Register Title	Default (Binary)	Bit No.	Description
1	0 0011	Color 4 PGA	0101 0100	[7:0]	The eight bit byte selected by the 5:1 PGA MUX in Mode 1a during Color 4 lines. Not used in Mode 1b, Mode 2 or Mode 3.
1	0 0100	Color 5 PGA	0101 0100	[7:0]	The eight bit byte selected by the 5:1 PGA MUX in Mode 1a during Color 5 lines. Not used in Mode 1b, Mode 2 or Mode 3.
1	0 0101	Color 1 Black Level DAC MSB	1000 0000	[7:0]	The MSBs selected by the 5:1 DAC MUX in Mode 1a during Color 1 lines. In Mode 1b/c, Mode 2 or Mode 3, the register used to define the DAC setting for the OS _R input. The DAC value is in offset Binary format.
1	0 0110	Color 1 Black Level DAC LSB	0000 0000	[7:0]	Color 1 Black Level DAC LSB
				[7:2]	Not Used
				[1:0]	The LSBs selected by the 5:1 DAC MUX in Mode 1a during Color 1 lines. In Mode 1b, Mode 2 or Mode 3, the register used to define the DAC setting for the OS _R input. The DAC value is in offset Binary format.
1	0 0111	Color 2 Black Level DAC MSB	1000 0000	[7:0]	The MSBs selected by the 5:1 DAC MUX in Mode 1a during Color 2 lines. In Mode 1b, Mode 2 or Mode 3, the register used to define the DAC setting for the OS _G input. The DAC value is in offset Binary format.
1	0 1000	Color 2 Black Level DAC LSB	0000 0000	[7:0]	Color 2 Black Level DAC LSB
				[7:2]	Not Used
				[1:0]	The LSBs selected by the 5:1 DAC MUX in Mode 1a during Color 2 lines. In Mode 1b, Mode 2 or Mode 3, the register used to define the DAC setting for the OS _G input. The DAC value is in offset Binary format.
1	0 1001	Color 3 Black Level DAC MSB	1000 0000	[7:0]	The MSBs selected by the 5:1 DAC MUX in Mode 1a during Color 3 lines. In Mode 1b, Mode 2 or Mode 3, the register used to define the DAC setting for the OS _B input. The DAC value is in offset Binary format.
1	0 1010	Color 3 Black Level DAC LSB	0000 0000	[7:0]	Color 3 Black Level DAC LSB
				[7:2]	Not Used
				[1:0]	The LSBs selected by the 5:1 DAC MUX in Mode 1a during Color 3 lines. In Mode 1b, Mode 2 or Mode 3, the register used to define the DAC setting for the OS _B input. The DAC value is in offset Binary format.
1	0 1011	Color 4 Black Level DAC MSB	1000 0000	[7:0]	The MSBs selected by the 5:1 DAC MUX in Mode 1a during Color 4 lines. Not used in Mode 1b, Mode 2 or Mode 3. The DAC value is in offset Binary format.
1	0 1100	Color 4 Black Level DAC LSB	0000 0000	[7:0]	Color 4 Black Level DAC LSB
				[7:2]	Not Used
				[1:0]	The LSBs selected by the 5:1 DAC MUX in Mode 1a during Color 4 lines. Not used in Mode 1b, Mode 2 or Mode 3. The DAC value is in offset Binary format.
1	0 1101	Color 5 Black Level DAC MSB	1000 0000	[7:0]	The MSBs selected by the 5:1 DAC MUX in Mode 1a during Color 5 lines. Not used in Mode 1b, Mode 2 or Mode 3. The DAC value is in offset Binary format.
1	0 1110	Color 5 Black Level DAC LSB	0000 0000	[7:0]	Color 5 Black Level DAC LSB
				[7:2]	Not Used
				[1:0]	The LSBs selected by the 5:1 DAC MUX in Mode 1a during Color 5 lines. Not used in Mode 1b/c, Mode 2 or Mode 3. The DAC value is in offset Binary format.
1	0 1111	Color 1 Digital Offset	0100 0000	[7:0]	Color 1 Digital Offset
				[7]	Not Used
				[6:0]	The Digital Offset applied to the ADC result in Mode 1a during Color 1 lines. In Mode 1b/c, Mode 2 or Mode 3, the register used to define the Digital Offset setting for the OS _R input. The DAC value is in offset Binary format.
1	1 0000	Color 2 Digital Offset	0100 0000	[7:0]	Color 2 Digital Offset
				[7]	Not Used
				[6:0]	The Digital Offset applied to the ADC result in Mode 1a during Color 2 lines. In Mode 1b/c, Mode 2 or Mode 3, the register used to define the DAC setting for the OS _G input. The DAC value is in offset Binary format.
1	1 0001	Color 3 Digital Offset	0100 0000	[7:0]	Color 3 Digital Offset
				[7]	Not Used
				[6:0]	The Digital Offset applied to the ADC result in Mode 1a during Color 3 lines. In Mode 1b/c, Mode 2 or Mode 3, the register used to define the DAC setting for the OS _B input. The DAC value is in offset Binary format.
1	1 0010	Color 4 Digital Offset	0100 0000	[7:0]	Color 4 Digital Offset
				[7]	Not Used
				[6:0]	The Digital Offset applied to the ADC result in Mode 1a during Color 4 lines. Not used in Mode 1b/c, Mode 2 or Mode 3. The DAC value is in offset Binary format.

Table 17. Register Descriptions (continued)

Page	Address (Binary)	Register Title	Default (Binary)	Bit No.	Description
1	1 0011	Color 5 Digital Offset	0100 0000	[7:0]	Color 5 Digital Offset
				[7]	Not Used
				[6:0]	The Digital Offset applied to the ADC result in Mode 1a during Color 5 lines. Not used in Mode 1b/c, Mode 2 or Mode 3. The DAC value is in offset Binary format.
1	1 1111	Page Register	0000 0000	[7:0]	Used to select desired page of registers being accessed.
Page 2 Registers					
2	0 0000	SH Mode	0000 0000	[7]	SH Output Enable.
					0 Enable SH Output
					1 SH Output Tristate
				[6]	SH Master/Slave Select.
					0 External SH_R input. CCD Timing Generator runs in Slave mode, with SH triggered by an external pulse on the SH_R pin.
					1 Auto generated SH. CCD Timing Generator runs in Master mode, with SH generated internally with a programmable period and width.
				[5:4]	SH Output Mode.
					00 SH Output = SH
					01 SH Output = SH
					10 SH Output = 0
[3:0]	11 SH Output = 1				
	SH Delay from SH_R				
	Additional delay				
2	0 0001	SH Pulse Width	0010 0111	[7:0]	SH Pulse Width
					SH Pulse Width = (2 * [7:0]) + 1
2	0 0010	PIX1/2 Control	1100 1000	[7]	PIX1 Activity
					0 Disabled
					1 Enabled
				[6]	PIX1 Polarity
					0 Normal - Low when off
					1 Inverted - High when off
				[5]	PIX1 Frequency
					0 Pixel Rate
					1 1/2 Pixel Rate
				[4]	PIX1 Activity During SH
					0 Inactive
				[3]	1 Active
					PIX2 Activity
					0 Disabled
				[2]	1 Enabled
					PIX2 Polarity
0 Normal - Low when off					
[1]	1 Inverted - High when off				
	PIX2 Frequency				
	0 Pixel Rate				
[0]	1 1/2 Pixel Rate				
	PIX2 Activity During SH				
	0 Inactive				
					1 Active

Table 17. Register Descriptions (continued)

Page	Address (Binary)	Register Title	Default (Binary)	Bit No.	Description
2	0 0011	PIX3/4 Control	1000 1000	[7]	PIX3 Activity
					0 Disabled
					1 Enabled
				[6]	PIX3 Polarity
					0 Normal - Low when off
					1 Inverted - High when off
				[5]	PIX3 Frequency
					0 Pixel Rate
					1 1/2 Pixel Rate
				[4]	PIX3 Activity During SH
					0 Inactive
					1 Active
				[3]	PIX4 Activity
					0 Disabled
					1 Enabled
				[2]	PIX4 Polarity
0 Normal - Low when off					
1 Inverted - High when off					
[1]	PIX4 Frequency				
	0 Pixel Rate				
	1 1/2 Pixel Rate				
[0]	PIX4 Activity During SH				
	0 Inactive				
	1 Active				
2	0 0100	PIX5/6 Control	0000 0000	[7]	PIX5 Activity
					0 Disabled
					1 Enabled
				[6]	PIX5 Polarity
					0 Normal - Low when off
					1 Inverted - High when off
				[5]	PIX5 Frequency
					0 Pixel Rate
					1 1/2 Pixel Rate
				[4]	PIX5 Activity During SH
					0 Inactive
					1 Active
				[3]	PIX6 Activity
					0 Disabled
					1 Enabled
				[2]	PIX6 Polarity
0 Normal - Low when off.					
1 Inverted - High when off.					
[1]	PIX6 Frequency				
	0 Pixel Rate				
	1 1/2 Pixel Rate				
[0]	PIX6 Activity During SH				
	0 Inactive				
	1 Active				

Table 17. Register Descriptions (continued)

Page	Address (Binary)	Register Title	Default (Binary)	Bit No.	Description
2	0 0101	PIX7/8 Control	0000 0000	[7]	PIX7 Activity
					0 Disabled
					1 Enabled
				[6]	PIX7 Polarity
					0 Normal - Low when off
					1 Inverted - High when off
				[5]	PIX7 Frequency
					0 Pixel Rate
					1 1/2 Pixel Rate
				[4]	PIX7 Activity During SH
					0 Inactive
					1 Active
				[3]	PIX8 Activity
					0 Disabled
					1 Enabled
				[2]	PIX8 Polarity
0 Normal - Low when off					
1 Inverted - High when off					
[1]	PIX8 Frequency				
	0 Pixel Rate				
	1 1/2 Pixel Rate				
[0]	PIX8 Activity During SH				
	0 Inactive				
	1 Active				
2	0 0110	Line Clamp Enable	0000 0000	[7]	PIX8 Line Clamp Enable. Enables single Line Clamp pulse per line from PIX8.
					0 Disabled. PIX generator functions as normal.
					1 Enabled. PIX generates a single clock per line for Line Clamp function.
				[6]	PIX7 Line Clamp Enable. Enables single Line Clamp pulse per line from PIX7.
					0 Disabled. PIX generator functions as normal.
					1 Enabled. PIX generates a single clock per line for Line Clamp function.
				[5]	PIX6 Line Clamp Enable. Enables single Line Clamp pulse per line from PIX6.
					0 Disabled. PIX generator functions as normal.
					1 Enabled. PIX generates a single clock per line for Line Clamp function.
				[4]	PIX5 Line Clamp Enable. Enables single Line Clamp pulse per line from PIX5.
					0 Disabled. PIX generator functions as normal.
					1 Enabled. PIX generates a single clock per line for Line Clamp function.
				[3]	PIX4 Line Clamp Enable. Enables single Line Clamp pulse per line from PIX4.
					0 Disabled. PIX generator functions as normal.
					1 Enabled. PIX generates a single clock per line for Line Clamp function.
				[2]	PIX3 Line Clamp Enable. Enables single Line Clamp pulse per line from PIX3.
					0 Disabled. PIX generator functions as normal.
					1 Enabled. PIX generates a single clock per line for Line Clamp function.
				[1]	PIX2 Line Clamp Enable. Enables single Line Clamp pulse per line from PIX2.
					0 Disabled. PIX generator functions as normal.
					1 Enabled. PIX generates a single clock per line for Line Clamp function.
				[0]	PIX1 Line Clamp Enable. Enables single Line Clamp pulse per line from PIX1.
					0 Disabled. PIX generator functions as normal.
					1 Enabled. PIX generates a single clock per line for Line Clamp function.
2	0 0111	PIX1 Start	0000 0000	[7]	Reserved. Set to 0.
				[6:0]	PIX1 on point. Defines when the PIX1 signal turns on within the pixel period. Can be set to any available edge within the pixel period. (For 1/2 frequency signals, the count can be any available edge within 2 pixel periods)
2	0 1000	PIX1 End	0001 0101	[7]	Reserved. Set to 0.
				[6:0]	PIX1 off point. Defines when the PIX1 signal turns off within the pixel period. Can be set to any available edge within the pixel period. (For 1/2 frequency signals, the count can be any available edge within 2 pixel periods)

Table 17. Register Descriptions (continued)

Page	Address (Binary)	Register Title	Default (Binary)	Bit No.	Description
2	0 1010	PIX2 Start	0000 0000	[7]	Reserved. Set to 0.
				[6:0]	PIX2 on point. Defines when the PIX2 signal turns on within the pixel period. Can be set to any available edge within the pixel period. (For 1/2 frequency signals, the count can be any available edge within 2 pixel periods)
2	0 1011	PIX2 End	0001 0101	[7]	Reserved. Set to 0.
				[6:0]	PIX2 off point. Defines when the PIX2 signal turns off within the pixel period. Can be set to any available edge within the pixel period. (For 1/2 frequency signals, the count can be any available edge within 2 pixel periods)
2	0 1101	PIX3 Start	0000 1011	[7]	Reserved. Set to 0.
				[6:0]	PIX3 on point. Defines when the PIX3 signal turns on within the pixel period. Can be set to any available edge within the pixel period. (For 1/2 frequency signals, the count can be any available edge within 2 pixel periods)
2	0 1110	PIX3 End	0000 1101	[7]	Reserved. Set to 0.
				[6:0]	PIX3 off point. Defines when the PIX3 signal turns off within the pixel period. Can be set to any available edge within the pixel period. (For 1/2 frequency signals, the count can be any available edge within 2 pixel periods)
2	1 0000	PIX4 Start	0001 0000	[7]	Reserved. Set to 0.
				[6:0]	PIX4 on point. Defines when the PIX4 signal turns on within the pixel period. Can be set to any available edge within the pixel period. (For 1/2 frequency signals, the count can be any available edge within 2 pixel periods)
2	1 0001	PIX4 End	0001 0011	[7]	Reserved. Set to 0.
				[6:0]	PIX4 off point. Defines when the PIX4 signal turns off within the pixel period. Can be set to any available edge within the pixel period. (For 1/2 frequency signals, the count can be any available edge within 2 pixel periods)
2	1 0011	PIX5 Start	0000 0000	[7]	Reserved. Set to 0.
				[6:0]	PIX5 on point. Defines when the PIX5 signal turns on within the pixel period. Can be set to any available edge within the pixel period. (For 1/2 frequency signals, the count can be any available edge within 2 pixel periods)
2	1 0100	PIX5 End	0000 0000	[7]	Reserved. Set to 0.
				[6:0]	PIX5 off point. Defines when the PIX5 signal turns off within the pixel period. Can be set to any available edge within the pixel period. (For 1/2 frequency signals, the count can be any available edge within 2 pixel periods)
2	1 0110	PIX6 Start	0000 0000	[7]	Reserved. Set to 0.
				[6:0]	PIX6 on point. Defines when the PIX6 signal turns on within the pixel period. Can be set to any available edge within the pixel period. (For 1/2 frequency signals, the count can be any available edge within 2 pixel periods)
2	1 0111	PIX6 End	0000 0000	[7]	Reserved. Set to 0.
				[6:0]	PIX6 off point. Defines when the PIX6 signal turns off within the pixel period. Can be set to any available edge within the pixel period. (For 1/2 frequency signals, the count can be any available edge within 2 pixel periods)
2	1 1001	PIX7 Start	0000 0000	[7]	Reserved. Set to 0.
				[6:0]	PIX7 on point. Defines when the PIX7 signal turns on within the pixel period. Can be set to any available edge within the pixel period. (For 1/2 frequency signals, the count can be any available edge within 2 pixel periods)
2	1 1010	PIX7 End	0000 0000	[7]	Reserved. Set to 0.
				[6:0]	PIX7 off point. Defines when the PIX7 signal turns off within the pixel period. Can be set to any available edge within the pixel period. (For 1/2 frequency signals, the count can be any available edge within 2 pixel periods)
2	1 1100	PIX8 Start	0000 0000	[7]	Reserved. Set to 0.
				[6:0]	PIX8 on point. Defines when the PIX8 signal turns on within the pixel period. Can be set to any available edge within the pixel period. (For 1/2 frequency signals, the count can be any available edge within 2 pixel periods)
2	1 1101	PIX8 End	0000 0000	[7]	Reserved. Set to 0.
				[6:0]	PIX8 off point. Defines when the PIX8 signal turns off within the pixel period. Can be set to any available edge within the pixel period. (For 1/2 frequency signals, the count can be any available edge within 2 pixel periods)
2	1 1110	CMOS Data Mode Status Bit Enable	0000 0000	[7:6]	Reserved. Set to 000 When mapping the CLK5 to CLK10 pins as either CLKOUT or CB outputs, the Sample Timing Monitor 1 (Page 4, Register 0x0C) cannot be used.
				[5]	0 - CLK10 mapped normally, 1- CLK10 = CLKOUT
				[4]	0 - CLK9 mapped normally, 1- CLK9 = CB[4] status bit
				[3]	0 - CLK8 mapped normally, 1- CLK8 = CB[3] status bit
				[2]	0 - CLK7 mapped normally, 1- CLK7 = CB[2] status bit
				[1]	0 - CLK6 mapped normally, 1- CLK6 = CB[1] status bit
				[0]	0 - CLK5 mapped normally, 1- CLK5 = CB[0] status bit
2	1 1111	Page Register	0000 0000	[7:0]	Used to select desired page of registers being accessed.

Table 17. Register Descriptions (continued)

Page	Address (Binary)	Register Title	Default (Binary)	Bit No.	Description
Page 3 Registers					
3	0 0000	Output Mapping CLK1/CLK2 This register sets which timing signal is present on the respective CLKn output pin.	0000 0000	[7:4] CLK 1	Setting CLKn =
					0000 Tristate
					0001 PIX1
					0010 PIX2
					0011 PIX3
					0100 PIX4
					0101 PIX5
				0110 PIX6	
				0111 PIX7	
				[3:0] CLK 2	1000 PIX8
					1001 LAMP _R
					1010 LAMP _G
					1011 LAMP _B
					1100 LAMPIR1
1101 LAMPIR2					
1110 MODE					
1111 SH					
3	0 0001	Output Mapping CLK3/CLK4 This register sets which timing signal is present on the respective CLKn output pin.	0000 0000	[7:4] CLK 3	Setting CLKn =
					0000 Tristate
					0001 PIX1
					0010 PIX2
					0011 PIX3
					0100 PIX4
					0101 PIX5
				0110 PIX6	
				0111 PIX7	
				[3:0] CLK 4	1000 PIX8
					1001 LAMP _R
					1010 LAMP _G
					1011 LAMP _B
					1100 LAMPIR1
1101 LAMPIR2					
1110 MODE					
1111 SH					
3	0 0010	Output Mapping CLK5/CLK6 This register sets which timing signal is present on the respective CLKn output pin.	0000 0000	[7:0] CLK 5	Setting CLKn =
					0000 Tristate
					0001 PIX1
					0010 PIX2
					0011 PIX3
					0100 PIX4
					0101 PIX5
				0110 PIX6	
				0111 PIX7	
				[3:0] CLK 6	1000 PIX8
					1001 LAMP _R
					1010 LAMP _G
					1011 LAMP _B
					1100 LAMPIR1
1101 LAMPIR2					
1110 MODE					
1111 SH					

Table 17. Register Descriptions (continued)

Page	Address (Binary)	Register Title	Default (Binary)	Bit No.	Description
3	0 0011	Output Mapping CLK7/CLK8 This register sets which timing signal is present on the respective CLKn output pin.	0000 0000	[7:0] CLK 7	Setting CLKn =
					0000 Tristate
					0001 PIX1
					0010 PIX2
					0011 PIX3
					0100 PIX4
					0101 PIX5
				[3:0] CLK 8	0110 PIX6
					0111 PIX7
					1000 PIX8
					1001 LAMP _R
					1010 LAMP _G
					1011 LAMP _B
					1100 LAMPIR1
3	0 0100	Output Mapping CLK9/CLK10 This register sets which timing signal is present on the respective CLKn output pin.	0000 0000	[7:4] CLK 9	Setting CLKn =
					0000 Tristate
					0001 PIX1
					0010 PIX2
					0011 PIX3
					0100 PIX4
					0101 PIX5
				[3:0] CLK 10	0110 PIX6
					0111 PIX7
					1000 PIX8
					1001 LAMP _R
					1010 LAMP _G
					1011 LAMP _B
					1100 LAMPIR1
3	0 0101	Illumination Mode (see also AFE color modes)	0000 0000	[7]	LAMP _R Normal State
					0 = Low, 1 = High
				[6]	LAMP _G Normal State
					0 = Low, 1 = High
				[5]	LAMP _B Normal State
					0 = Low, 1 = High
				[4]	LampIR1 Normal State
					0 = Low, 1 = High
				[3]	LampIR2 Normal State
					0 = Low, 1 = High
[2:1]	Reserved				
[0]	SH/LAMP Overlap Enable				
	0 Disabled				
	1 Overlap Enabled				

Table 17. Register Descriptions (continued)

Page	Address (Binary)	Register Title	Default (Binary)	Bit No.	Description
3	0 0110	Line 1 Lamp Selection	0000 0000	[7:5]	Reserved. Set to 000
				[4]	Red Lamp Enable
					0 Red Disabled
					1 Red Enabled
				[3]	Green Lamp Enable
					0 Green Disabled
				[2]	1 Green Enabled
					Blue Lamp Enable
					0 Blue Disabled
				[1]	1 Blue Enabled
					IR1 Lamp Enable
				[0]	0 IR1 Disabled
1 IR1 Enabled					
IR2 Lamp Enable					
[0]	0 IR2 Disabled				
	1 IR2 Enabled				
3	0 0111	Line 2 Lamp Selection	0000 0000	[7:5]	Reserved. Set to 000
				[4]	Red Lamp Enable
					0 Red Disabled
					1 Red Enabled
				[3]	Green Lamp Enable
					0 Green Disabled
				[2]	1 Green Enabled
					Blue Lamp Enable
					0 Blue Disabled
				[1]	1 Blue Enabled
					IR1 Lamp Enable
				[0]	0 IR1 Disabled
1 IR1 Enabled					
IR2 Lamp Enable					
[0]	0 IR2 Disabled				
	1 IR2 Enabled				
3	0 1000	Line 3 Lamp Selection	0000 0000	[7:5]	Reserved. Set to 000
				[4]	Red Lamp Enable
					0 Red Disabled
					1 Red Enabled
				[3]	Green Lamp Enable
					0 Green Disabled
				[2]	1 Green Enabled
					Blue Lamp Enable
					0 Blue Disabled
				[1]	1 Blue Enabled
					IR1 Lamp Enable
				[0]	0 IR1 Disabled
1 IR1 Enabled					
IR2 Lamp Enable					
[0]	0 IR2 Disabled				
	1 IR2 Enabled				

Table 17. Register Descriptions (continued)

Page	Address (Binary)	Register Title	Default (Binary)	Bit No.	Description
3	0 1001	Line 4 Lamp Selection	0000 0000	[7:5]	Reserved. Set to 000
				[4]	Red Lamp Enable
					0 Red Disabled
					1 Red Enabled
				[3]	Green Lamp Enable
					0 Green Disabled
				[2]	1 Green Enabled
					Blue Lamp Enable
					0 Blue Disabled
				[1]	1 Blue Enabled
					IR1 Lamp Enable
				[0]	0 IR1 Disabled
1 IR1 Enabled					
IR2 Lamp Enable					
3	0 1010	Line 5 Lamp Selection	0000 0000	[7:5]	Reserved. Set to 000
				[4]	Red Lamp Enable
					0 Red Disabled
					1 Red Enabled
				[3]	Green Lamp Enable
					0 Green Disabled
				[2]	1 Green Enabled
					Blue Lamp Enable
					0 Blue Disabled
				[1]	1 Blue Enabled
					IR1 Lamp Enable
				[0]	0 IR1 Disabled
1 IR1 Enabled					
IR2 Lamp Enable					
[0]	0 IR2 Disabled				
	1 IR2 Enabled				
	LAMP _R On Time Most Significant Bits				
3	0 1011	LAMP _R On MSB	0000 0000	[7:5]	Reserved. Set to 000
				[4]	LAMP _R SH_OR Enable
					0 No ORing
[3:0]	1 LAMP _R uses SH_OR function				
	LAMP _R On Time Least Significant Byte				
3	0 1100	LAMP _R On LSB	0001 0001	[7:0]	This selects the pixel count at which the LAMP _R output goes high.
				LAMP _R Off MSB	
3	0 1101	LAMP _R Off MSB	0000 0011	[7:4]	Reserved. Set to 0000
				[3:0]	LAMP _R Off Time Most Significant Bits
3	0 1110	LAMP _R Off LSB	0000 0110	[7:0]	LAMP _R Off Time Least Significant Byte
				This selects the pixel count at which the LAMP _R output goes low.	
3	0 1111	LAMP _G On MSB	0000 0000	[7:5]	Reserved. Set to 000
				[4]	LAMP _G SH_OR Enable.
					0 No ORing
					1 LAMP _G uses SH_OR function
				[3:0]	LAMP _G On Time Most Significant Bits.
This selects the pixel count at which the LAMP _R output goes high.					
3	1 0000	LAMP _G On LSB	0001 0010	[7:0]	LAMP _G On Time Least Significant Byte
					This selects the pixel count at which the LAMP _R output goes high.

Table 17. Register Descriptions (continued)

Page	Address (Binary)	Register Title	Default (Binary)	Bit No.	Description
3	1 0001	LAMP _G Off MSB	0000 0011	[7:4]	Reserved. Set to 0000
				[3:0]	LAMP _G Off Time Most Significant Bits This selects the pixel count at which the LAMP _R output goes low.
3	1 0010	LAMP _G Off LSB	0000 0000	[7:0]	LAMP _G Off Time Least Significant Byte This selects the pixel count at which the LAMP _R output goes low.
				[7:5]	Reserved. Set to 000
3	1 0011	LAMP _B On MSB	0000 0000	[4]	LAMP _B SH_OR Enable 0 No ORing 1 LAMP _B uses SH_OR function
				[3:0]	LAMP _B On Time Most Significant Bits This selects the pixel count at which the LAMP _R output goes high.
				[7:0]	LAMP _B On Time Least Significant Byte This selects the pixel count at which the LAMP _R output goes high.
3	1 0100	LAMP _B On LSB	0001 0011	[7:0]	LAMP _B On Time Least Significant Byte This selects the pixel count at which the LAMP _R output goes high.
3	1 0101	LAMP _B Off MSB	0000 0011	[7:4]	Reserved. Set to 0000
				[3:0]	LAMP _B Off Time Most Significant Bits This selects the pixel count at which the LAMP _R output goes low.
3	1 0110	LAMP _B Off LSB	0011 0000	[7:0]	LAMP _B Off Time Least Significant Byte This selects the pixel count at which the LAMP _R output goes low.
				[7:5]	Reserved. Set to 000
3	1 0111	LAMPIR1 On MSB	0000 0000	[4]	LAMPIR1 SH_OR Enable 0 No ORing 1 LAMPIR1 uses SH_OR function
				[3:0]	LAMPIR1 On Time Most Significant Bits This selects the pixel count at which the LAMP _R output goes high.
				[7:0]	LAMPIR1 On Time Least Significant Byte This selects the pixel count at which the LAMP _R output goes high.
3	1 1000	LAMPIR1 On LSB	0001 0100	[7:0]	LAMPIR1 On Time Least Significant Byte This selects the pixel count at which the LAMP _R output goes high.
3	1 1001	LAMPIR1 Off MSB	0000 0011	[7:4]	Reserved. Set to 0000
				[3:0]	LAMPIR1 Off Time Most Significant Bits This selects the pixel count at which the LAMP _R output goes low.
3	1 1010	LAMPIR1 Off LSB	0011 0000	[7:0]	LAMPIR1 Off Time Least Significant Byte This selects the pixel count at which the LAMP _R output goes low.
				[7:5]	Reserved. Set to 000
3	1 1011	LAMPIR2 On MSB	0000 0000	[4]	LAMPIR2 SH_OR Enable. 0 No ORing 1 LAMPIR2 uses SH_OR function
				[3:0]	LAMPIR2 On Time Most Significant Bits. This selects the pixel count at which the LAMP _R output goes high.
				[7:0]	LAMPIR2 On Time Least Significant Byte This selects the pixel count at which the LAMP _R output goes high.
3	1 1101	LAMPIR2 Off MSB	0000 0011	[7:4]	Reserved. Set to 0000
				[3:0]	LAMPIR2 Off Time Most Significant Bits This selects the pixel count at which the LAMP _R output goes low.
3	1 1110	LAMPIR2 Off LSB	0011 0000	[7:0]	LAMPIR2 Off Time Least Significant Byte This selects the pixel count at which the LAMP _R output goes low.
				[7:0]	Used to select desired page of registers being accessed.
Page 4 Registers					
4	0 0000	Mode On MSB	0000 0010	[7:4]	Reserved. Set to 0000
				[3:0]	Mode On Time Most Significant Bits This selects the pixel count at which the Mode output goes high.
4	0 0001	Mode On LSB	0000 0000	[7:0]	Mode On Time Least Significant Byte This selects the pixel count at which the Mode output goes high.
				[7:4]	Reserved. Set to 0000
4	0 0010	Mode Off MSB	0000 0011	[3:0]	Mode Off Time Most Significant Bits This selects the pixel count at which the Mode output goes low.

Table 17. Register Descriptions (continued)

Page	Address (Binary)	Register Title	Default (Binary)	Bit No.	Description
4	0 0011	Mode Off LSB	0000 0001	[7:0]	Mode Off Time Least Significant Byte This selects the pixel count at which the Mode output goes low.
4	0 0100	Optical Black Pixels Start	0000 0000	[7:0]	Starting point for optical black clamping nnnnnnnn - n pixels (0-255)
4	0 0101	Optical Black Pixels End	0000 0000	[7:0]	End point for optical black clamping nnnnnnnn - n pixels (0-255)
4	0 0110	Start of Valid Pixels - MSB	0000 0000	[7:6] [5:0]	Reserved. Set to 00 Start of Valid Pixels - Most Significant Bits. Selects the pixel count where the data status bits begin to indicate valid pixels.
4	0 0111	Start of Valid Pixels - LSB	0000 0000	[7:0]	Start of Valid Pixels - Least Significant Bits. Selects the pixel count where the data status bits begin to indicate valid pixels.
4	0 1000	End of Valid Pixels - MSB	0011 1111	[7:6] [5:0]	Reserved. Set to 00 End of Valid Pixels - Most Significant Bits. Selects the pixel count where the data status bits stop indicating valid pixels.
4	0 1001	End of Valid Pixels - LSB	1111 1110	[7:0]	End of Valid Pixels - Least Significant Bits. Selects the pixel count where the data status bits stop indicating valid pixels.
4	0 1010	Line End - MSB	0011 1111	[7:6] [5:0]	Reserved. Set to 00. Line End Value - Most Significant 6 Bits Selects the pixel count where the current line is ended and the next one begins. Controls the integration time of one line and the period between SH pulses.
4	0 1011	Line End - LSB	1111 1111	[7:0]	Line End Value Least Significant Byte Selects the pixel count where the current line is ended and the next one begins. Controls the integration time of one line and the period between SH pulses. n pixels (0 - 16383)
4	0 1100	Sample Timing Monitor 1	1111 1111	[7:0] [7:4] [3:0]	Enables Sample and Clamp timing signals to be observed on one of the sensor timing control outputs. This function overrides any other settings for sensor control signal mapping. Important Note: Sample Timing Monitor 1 cannot be used if the CMOS Data Mode Status Bit Enable Register (Page 2, Register 0x1E) is being programmed to map CLKOUT to CLK10 or any Control Bit to CLK5-CLK9. Sample Timing Monitors 2 and 3 are not effected by this limitation. Upper 4 bits select timing signal to be monitored. 0000 Sample Red 0001 Clamp Red 0010 Sample Green 0011 Clamp Green 0100 Sample Blue 0101 Clamp Blue 1111 No signal monitored Lower 4 bits select which output pin is used as a monitor. 0000 CLK1 0001 CLK2 0010 CLK3 0011 CLK4 0100 CLK5 0101 CLK6 0110 CLK7 0111 CLK8 1000 CLK9 1001 CLKOUT/CLK10 1111 All outputs normal

Table 17. Register Descriptions (continued)

Page	Address (Binary)	Register Title	Default (Binary)	Bit No.	Description
4	0 1101	Sample Timing Monitor 2	1111 1111	[7:0]	Enables Sample and Clamp timing signals to be observed on one of the sensor timing control outputs. This function overrides any other settings for sensor control signal mapping.
				[7:4]	Upper 4 bits select timing signal to be monitored.
					0000 Sample Red
					0001 Clamp Red
					0010 Sample Green
					0011 Clamp Green
					0100 Sample Blue
					0101 Clamp Blue
					1111 No signal monitored
				[3:0]	Lower 4 bits select which output pin is used as a monitor.
					0000 CLK1
					0001 CLK2
					0010 CLK3
					0011 CLK4
					0100 CLK5
0101 CLK6					
0110 CLK7					
0111 CLK8					
1000 CLK9					
1001 CLKOUT/CLK10					
1111 All outputs normal					
4	0 1110	Sample Timing Monitor 3	1111 1111	[7:0]	Enables Sample and Clamp timing signals to be observed on one of the sensor timing control outputs. This function overrides any other settings for sensor control signal mapping.
				[7:4]	Upper 4 bits select timing signal to be monitored.
					0000 Sample Red
					0001 Clamp Red
					0010 Sample Green
					0011 Clamp Green
					0100 Sample Blue
					0101 Clamp Blue
					1111 No signal monitored
				[3:0]	Lower 4 bits select which output pin is used as a monitor.
					0000 CLK1
					0001 CLK2
					0010 CLK3
					0011 CLK4
					0100 CLK5
0101 CLK6					
0110 CLK7					
0111 CLK8					
1000 CLK9					
1001 CLKOUT/CLK10					
1111 All outputs normal					
4	0 1111	SH2/SH3 Control	0000 0000	[7:0]	Controls the optional SH2 and SH3 output signals. These signals can override the Lamp IR1 and Lamp IR2 outputs if additional SH signals are required.
				[7:4]	Not Used.
				[3]	SH3 Output Select.
					0 Lamp IR2 output is programmed from Lamp IR2 Generator 1 Lamp IR2 output is SH3
				[2]	SH2 Output Select. 0 Lamp IR1 output is programmed from Lamp IR1 Generator 1 Lamp IR1 output is SH2
				[1:0]	Not Used

Table 17. Register Descriptions (continued)

Page	Address (Binary)	Register Title	Default (Binary)	Bit No.	Description
4	1 0000	PIX OR/NOR Control 1	0000 0000	[7:0]	Controls the optional OR and NOR operations on the PIX generator outputs as described below. These signals can override the normal PIX generator outputs to provide OR and NOR functionality for uses such as Pixel Lumping. If multiple functions are selected, the order of priority from highest to lowest is PIX OR/NOR Control 1 Bit[0] to Bit [7], then PIX OR/NOR Control 2 Bit[0] to Bit[7] (i.e PIX OR/NOR Control 1 Bit[7] has a higher priority on the PIX5 output than PIX OR/NOR Control 2 Bit[0] or Bit[2]). For reference purposes, the normal, unmodified PIX generator outputs are named pix1 through pix8 (lower case) and the final signal prior to the CLK pins are named PIX1 through PIX8 (upper case).
				[0]	0 No effect (default); 1 PIX1 = ~(pix1 pix2)
				[1]	0 No effect (default); 1 PIX2 = (pix1 pix2)
				[2]	0 No effect (default); 1 PIX2 = ~(pix2 pix3)
				[3]	0 No effect (default); 1 PIX3 = (pix2 pix3)
				[4]	0 No effect (default); 1 PIX3 = ~(pix3 pix4)
				[5]	0 No effect (default); 1 PIX4 = (pix3 pix4)
				[6]	0 No effect (default); 1 PIX4 = ~(pix4 pix5)
				[7]	0 No effect (default); 1 PIX5 = (pix4 pix5)
4	1 0001	PIX OR/NOR Control 2	0000 0000	[7:0]	Controls the optional OR and NOR operations on the PIX generator outputs as described below. These signals can override the normal PIX generator outputs to provide OR and NOR functionality for uses such as Pixel Lumping. If multiple functions are selected, the order of priority from highest to lowest is PIX OR/NOR Control 1 Bit[0] to Bit [7], then PIX OR/NOR Control 2 Bit[0] to Bit[7] (i.e PIX OR/NOR Control 1 Bit[7] has a higher priority on the PIX5 output than PIX OR/NOR Control 2 Bit[0] or Bit[2]). For reference purposes, the normal, unmodified PIX generator outputs are named pix1 through pix8 (lower case) and the final signal prior to the CLK pins are named PIX1 through PIX8 (upper case).
				[0]	0 No effect (default); 1 PIX5 = ~(pix5 pix6)
				[1]	0 No effect (default); 1 PIX6 = (pix5 pix6)
				[2]	0 No effect (default); 1 PIX5 = ~(pix4 pix5 pix6)
				[3]	0 No effect (default); 1 PIX6 = (pix4 pix5 pix6)
				[4]	0 No effect (default); 1 PIX7 = ~(pix3 pix7 pix8)
				[5]	0 No effect (default); 1 PIX8 = (pix3 pix7 pix8)
				[6]	0 No effect (default); 1 PIX7 = ~(pix7 pix8)
				[7]	0 No effect (default); 1 PIX8 = (pix7 pix8)
4	1 1111	Page Register	0000 0000	[7:0]	Used to select desired page of registers being accessed.
Page 5 Registers					
5	0 0000	PIX1/SH On Guardbands	0000 1111	[7:0]	PIX1 on guardband. Number of pixel periods from end of SH pulse to start of PIX1.
5	0 0001	PIX1/SH Off Guardbands	0000 0111	[7:0]	PIX1 off guardband. Number of pixel periods before start of SH pulse that PIX1 stops.
5	0 0010	PIX2/SH On Guardbands	0000 1111	[7:0]	PIX2 on guardband. Number of pixel periods from end of SH pulse to start of PIX2.
5	0 0011	PIX2/SH Off Guardbands	0000 0111	[7:0]	PIX2 off guardband. Number of pixel periods before start of SH pulse that PIX2 stops.
5	0 0100	PIX3/SH On Guardbands	0000 1111	[7:0]	PIX3 on guardband. Number of pixel periods from end of SH pulse to start of PIX3.
5	0 0101	PIX3/SH Off Guardbands	0000 0111	[7:0]	PIX3 off guardband. Number of pixel periods before start of SH pulse that PIX3 stops.
5	0 0110	PIX4/SH On Guardbands	0000 1111	[7:0]	PIX4 on guardband. Number of pixel periods from end of SH pulse to start of PIX4.
5	0 0111	PIX4/SH Off Guardbands	0000 0111	[7:0]	PIX4 off guardband. Number of pixel periods before start of SH pulse that PIX4 stops.
5	0 1000	PIX5/SH On Guardbands	0000 1111	[7:0]	PIX5 on guardband. Number of pixel periods from end of SH pulse to start of PIX5.
5	0 1001	PIX5/SH Off Guardbands	0000 0111	[7:0]	PIX5 off guardband. Number of pixel periods before start of SH pulse that PIX5 stops.
5	0 1010	PIX6/SH On Guardbands	0000 1111	[7:0]	PIX6 on guardband. Number of pixel periods from end of SH pulse to start of PIX6.
5	0 1011	PIX6/SH Off Guardbands	0000 0111	[7:0]	PIX6 off guardband. Number of pixel periods before start of SH pulse that PIX6 stops.
5	0 1100	PIX7/SH On Guardbands	0000 1111	[7:0]	PIX7 on guardband. Number of pixel periods from end of SH pulse to start of PIX7.
5	0 1101	PIX7/SH Off Guardbands	0000 0111	[7:0]	PIX7 off guardband. Number of pixel periods before start of SH pulse that PIX7 stops.
5	0 1110	PIX8/SH On Guardbands	0000 1111	[7:0]	PIX8 on guardband. Number of pixel periods from end of SH pulse to start of PIX8.
5	0 1111	PIX8/SH Off Guardbands	0000 0111	[7:0]	PIX8 off guardband. Number of pixel periods before start of SH pulse that PIX8 stops.

8 Application and Implementation

NOTE

Information in the following applications sections is not part of the TI component specification, and TI does not warrant its accuracy or completeness. TI's customers are responsible for determining suitability of components for their purposes. Customers should validate and test their design implementation to confirm system functionality.

8.1 Typical Application

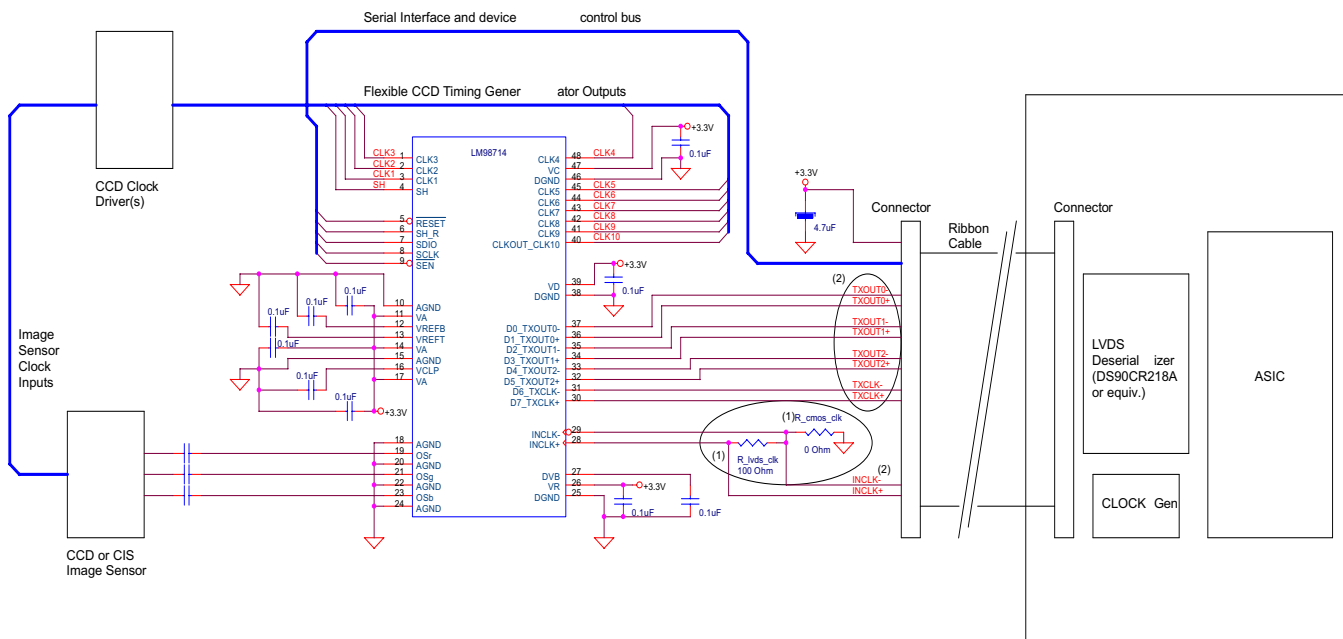

Copyright © 2017, Texas Instruments Incorporated

- (1) If using an LVDS input clock, terminate the clock at the pins with a 100-Ω resistor and remove the 0-Ω resistor from INCLK- to ground.
If using a CMOS input clock, short the INCLK- pin to ground and remove the 100-Ω LVDS termination resistor.
- (2) Maintain 100-Ω impedance for all LVDS differential pair paths.

Figure 61. Typical Application Diagram

9 Device and Documentation Support

9.1 Documentation Support

9.1.1 Device Support

9.1.1.1 Development Support

For development support see the [LM98714 IBIS Model](#).

9.1.2 Related Documentation

For related documentation see the following:

[AN-1538 Interfacing Texas Instruments DS90CR218A and LM98714](#)

9.2 Receiving Notification of Documentation Updates

To receive notification of documentation updates, navigate to the device product folder on ti.com. In the upper right corner, click on *Alert me* to register and receive a weekly digest of any product information that has changed. For change details, review the revision history included in any revised document.

9.3 Community Resources

The following links connect to TI community resources. Linked contents are provided "AS IS" by the respective contributors. They do not constitute TI specifications and do not necessarily reflect TI's views; see TI's [Terms of Use](#).

TI E2E™ Online Community *TI's Engineer-to-Engineer (E2E) Community*. Created to foster collaboration among engineers. At e2e.ti.com, you can ask questions, share knowledge, explore ideas and help solve problems with fellow engineers.

Design Support *TI's Design Support* Quickly find helpful E2E forums along with design support tools and contact information for technical support.

9.4 Trademarks

E2E is a trademark of Texas Instruments.
All other trademarks are the property of their respective owners.

9.5 Electrostatic Discharge Caution



This integrated circuit can be damaged by ESD. Texas Instruments recommends that all integrated circuits be handled with appropriate precautions. Failure to observe proper handling and installation procedures can cause damage.

ESD damage can range from subtle performance degradation to complete device failure. Precision integrated circuits may be more susceptible to damage because very small parametric changes could cause the device not to meet its published specifications.

9.6 Glossary

[SLYZ022](#) — *TI Glossary*.

This glossary lists and explains terms, acronyms, and definitions.

10 Mechanical, Packaging, and Orderable Information

The following pages include mechanical, packaging, and orderable information. This information is the most current data available for the designated devices. This data is subject to change without notice and revision of this document. For browser-based versions of this data sheet, refer to the left-hand navigation.

PACKAGING INFORMATION

Orderable part number	Status (1)	Material type (2)	Package Pins	Package qty Carrier	RoHS (3)	Lead finish/ Ball material (4)	MSL rating/ Peak reflow (5)	Op temp (°C)	Part marking (6)
LM98714BCMT/NOPB	Active	Production	TSSOP (DGG) 48	38 TUBE	Yes	SN	Level-2-260C-1 YEAR	0 to 70	LM98714 BCMT
LM98714BCMT/NOPB.A	Active	Production	TSSOP (DGG) 48	38 TUBE	Yes	SN	Level-2-260C-1 YEAR	0 to 70	LM98714 BCMT
LM98714BCMTX/NOPB	Active	Production	TSSOP (DGG) 48	1000 LARGE T&R	Yes	SN	Level-2-260C-1 YEAR	0 to 70	LM98714 BCMT
LM98714BCMTX/NOPB.A	Active	Production	TSSOP (DGG) 48	1000 LARGE T&R	Yes	SN	Level-2-260C-1 YEAR	0 to 70	LM98714 BCMT
LM98714CCMT/NOPB	Active	Production	TSSOP (DGG) 48	38 TUBE	Yes	SN	Level-2-260C-1 YEAR	0 to 70	LM98714 CCMT
LM98714CCMT/NOPB.A	Active	Production	TSSOP (DGG) 48	38 TUBE	Yes	SN	Level-2-260C-1 YEAR	0 to 70	LM98714 CCMT
LM98714CCMTX/NOPB	Active	Production	TSSOP (DGG) 48	1000 LARGE T&R	Yes	SN	Level-2-260C-1 YEAR	0 to 70	LM98714 CCMT
LM98714CCMTX/NOPB.A	Active	Production	TSSOP (DGG) 48	1000 LARGE T&R	Yes	SN	Level-2-260C-1 YEAR	0 to 70	LM98714 CCMT

(1) **Status:** For more details on status, see our [product life cycle](#).

(2) **Material type:** When designated, preproduction parts are prototypes/experimental devices, and are not yet approved or released for full production. Testing and final process, including without limitation quality assurance, reliability performance testing, and/or process qualification, may not yet be complete, and this item is subject to further changes or possible discontinuation. If available for ordering, purchases will be subject to an additional waiver at checkout, and are intended for early internal evaluation purposes only. These items are sold without warranties of any kind.

(3) **RoHS values:** Yes, No, RoHS Exempt. See the [TI RoHS Statement](#) for additional information and value definition.

(4) **Lead finish/Ball material:** Parts may have multiple material finish options. Finish options are separated by a vertical ruled line. Lead finish/Ball material values may wrap to two lines if the finish value exceeds the maximum column width.

(5) **MSL rating/Peak reflow:** The moisture sensitivity level ratings and peak solder (reflow) temperatures. In the event that a part has multiple moisture sensitivity ratings, only the lowest level per JEDEC standards is shown. Refer to the shipping label for the actual reflow temperature that will be used to mount the part to the printed circuit board.

(6) **Part marking:** There may be an additional marking, which relates to the logo, the lot trace code information, or the environmental category of the part.

Multiple part markings will be inside parentheses. Only one part marking contained in parentheses and separated by a "~" will appear on a part. If a line is indented then it is a continuation of the previous line and the two combined represent the entire part marking for that device.

Important Information and Disclaimer: The information provided on this page represents TI's knowledge and belief as of the date that it is provided. TI bases its knowledge and belief on information provided by third parties, and makes no representation or warranty as to the accuracy of such information. Efforts are underway to better integrate information from third parties. TI has taken and continues to take reasonable steps to provide representative and accurate information but may not have conducted destructive testing or chemical analysis on incoming materials and chemicals. TI and TI suppliers consider certain information to be proprietary, and thus CAS numbers and other limited information may not be available for release.

In no event shall TI's liability arising out of such information exceed the total purchase price of the TI part(s) at issue in this document sold by TI to Customer on an annual basis.

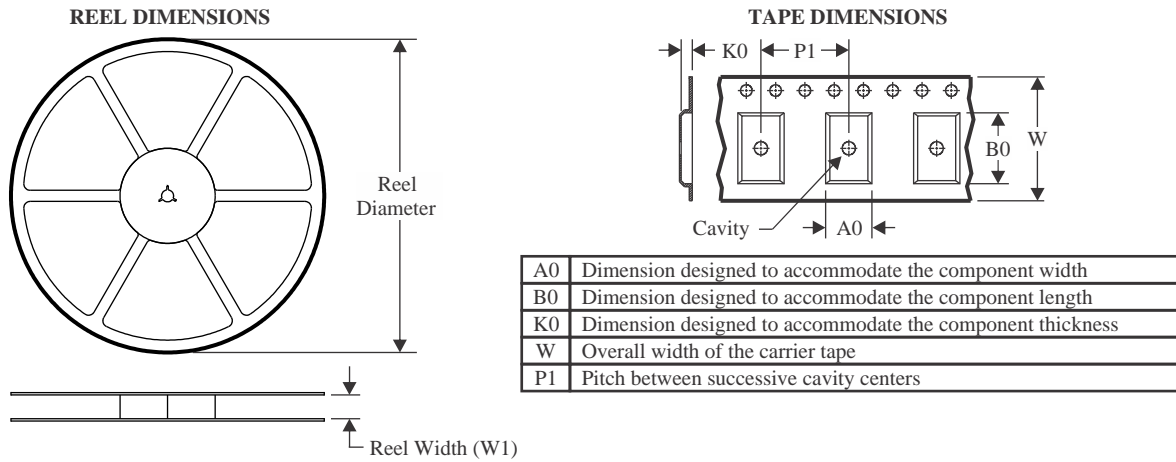
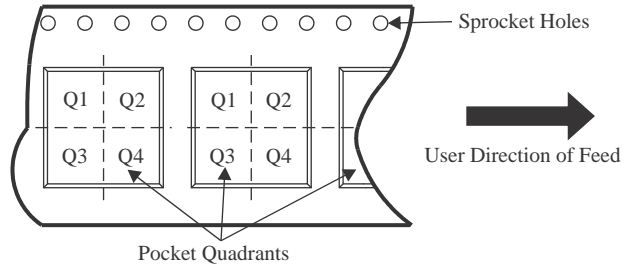
TAPE AND REEL INFORMATION

QUADRANT ASSIGNMENTS FOR PIN 1 ORIENTATION IN TAPE

*All dimensions are nominal

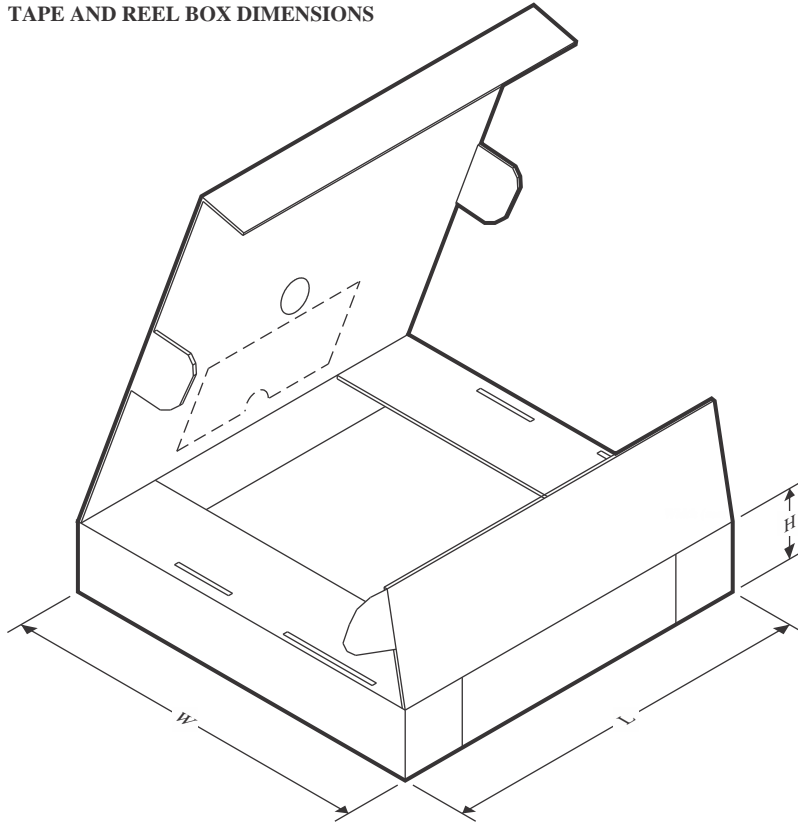
Device	Package Type	Package Drawing	Pins	SPQ	Reel Diameter (mm)	Reel Width W1 (mm)	A0 (mm)	B0 (mm)	K0 (mm)	P1 (mm)	W (mm)	Pin1 Quadrant
LM98714BCMTX/NOPB	TSSOP	DGG	48	1000	330.0	24.4	8.6	13.2	1.6	12.0	24.0	Q1
LM98714CCMTX/NOPB	TSSOP	DGG	48	1000	330.0	24.4	8.6	13.2	1.6	12.0	24.0	Q1

TAPE AND REEL BOX DIMENSIONS

*All dimensions are nominal

Device	Package Type	Package Drawing	Pins	SPQ	Length (mm)	Width (mm)	Height (mm)
LM98714BCMTX/NOPB	TSSOP	DGG	48	1000	356.0	356.0	45.0
LM98714CCMTX/NOPB	TSSOP	DGG	48	1000	356.0	356.0	45.0

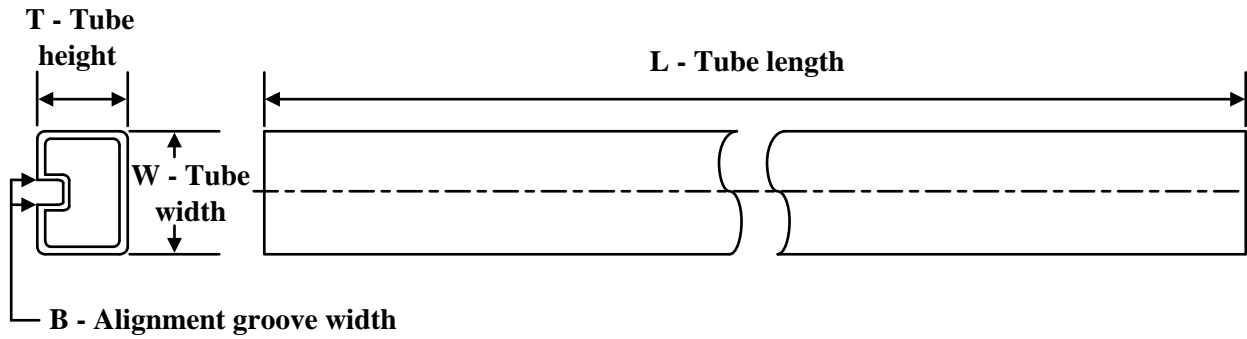
TUBE

*All dimensions are nominal

Device	Package Name	Package Type	Pins	SPQ	L (mm)	W (mm)	T (μm)	B (mm)
LM98714BCMT/NOPB	DGG	TSSOP	48	38	495	10	2540	5.79
LM98714BCMT/NOPB.A	DGG	TSSOP	48	38	495	10	2540	5.79
LM98714CCMT/NOPB	DGG	TSSOP	48	38	495	10	2540	5.79
LM98714CCMT/NOPB.A	DGG	TSSOP	48	38	495	10	2540	5.79

EXAMPLE BOARD LAYOUT

DGG0048A

TSSOP - 1.2 mm max height

SMALL OUTLINE PACKAGE

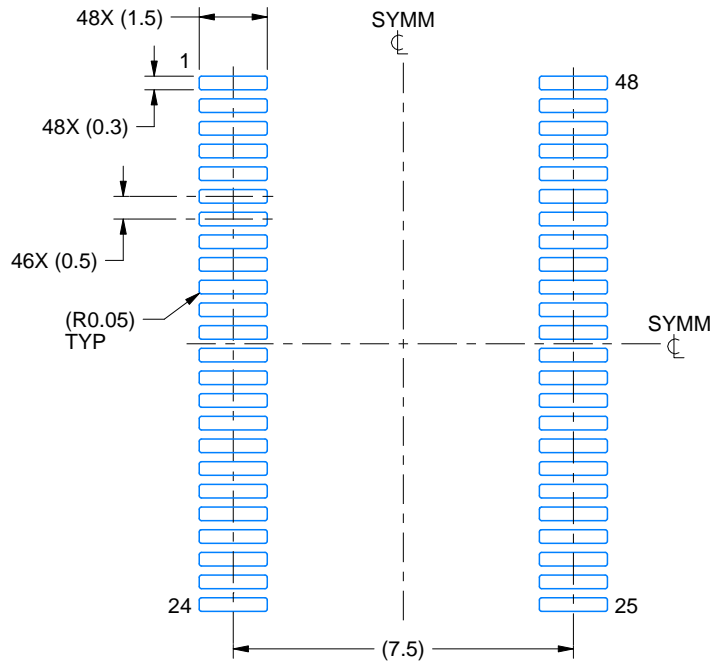

LAND PATTERN EXAMPLE
SCALE:6X

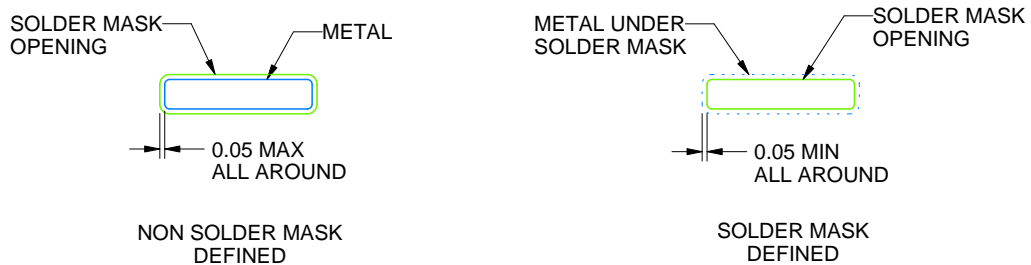

SOLDER MASK DETAILS

4214859/B 11/2020

NOTES: (continued)

5. Publication IPC-7351 may have alternate designs.
6. Solder mask tolerances between and around signal pads can vary based on board fabrication site.

EXAMPLE STENCIL DESIGN

DGG0048A

TSSOP - 1.2 mm max height

SMALL OUTLINE PACKAGE

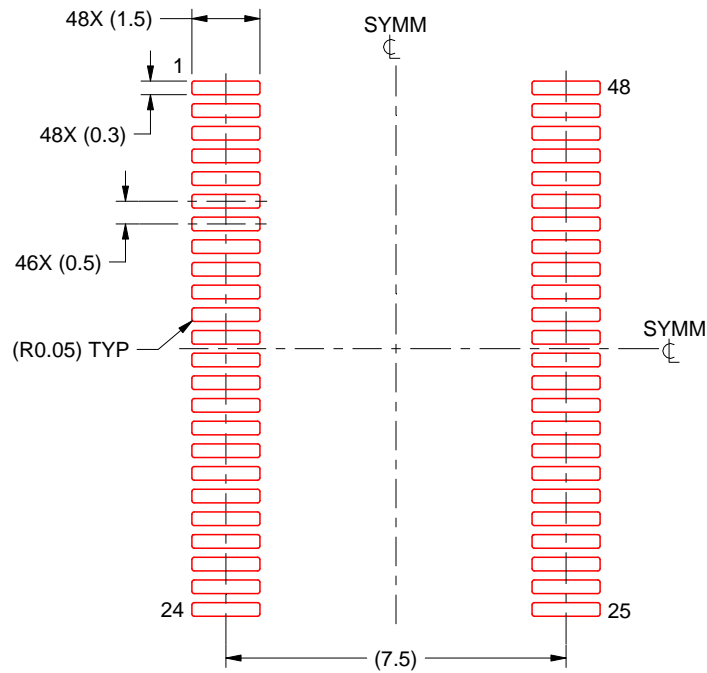

SOLDER PASTE EXAMPLE
BASED ON 0.125 mm THICK STENCIL
SCALE:6X

4214859/B 11/2020

NOTES: (continued)

7. Laser cutting apertures with trapezoidal walls and rounded corners may offer better paste release. IPC-7525 may have alternate design recommendations.
8. Board assembly site may have different recommendations for stencil design.

DGG (R-PDSO-G**)

PLASTIC SMALL-OUTLINE PACKAGE

48 PINS SHOWN

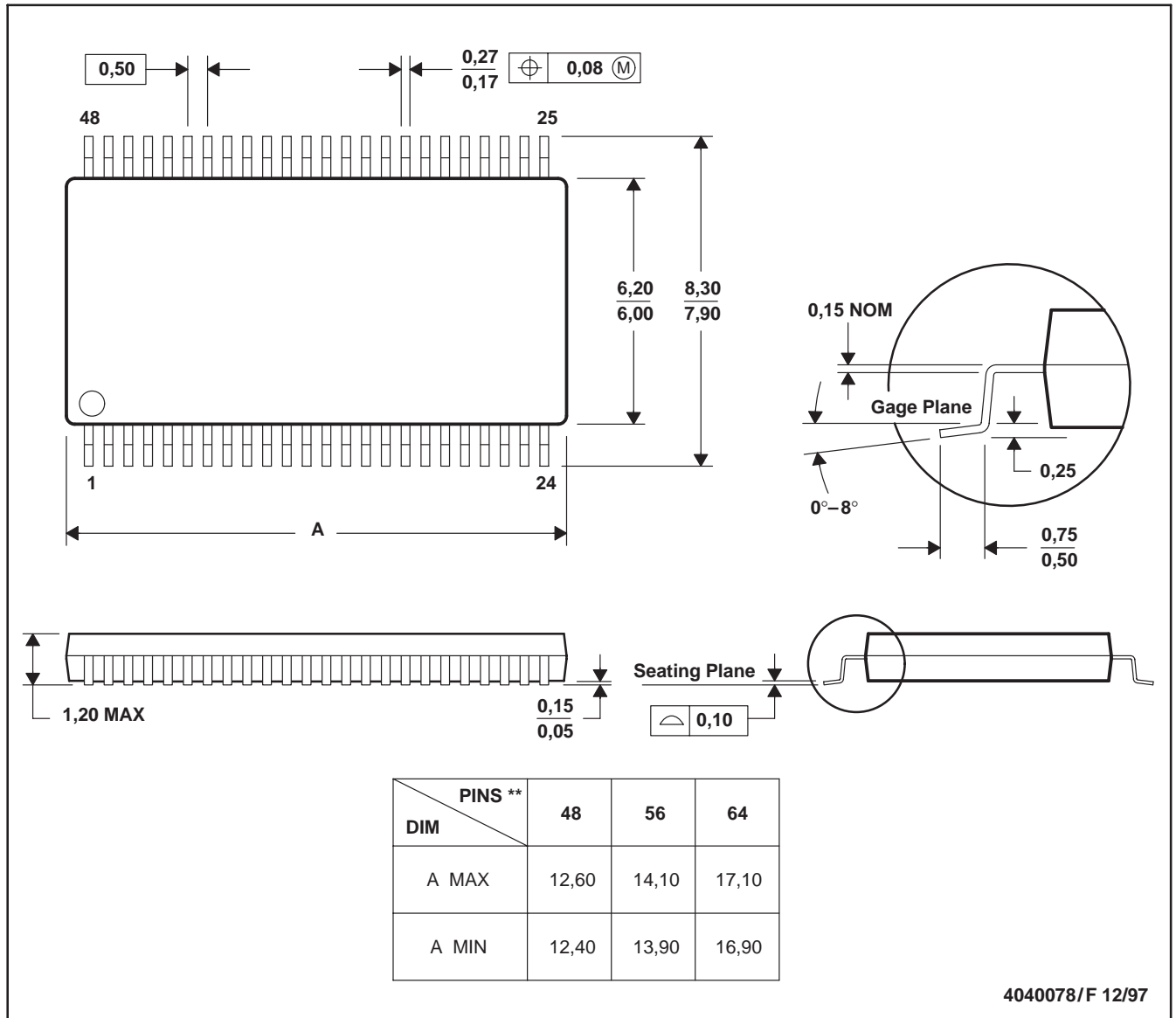

- NOTES: A. All linear dimensions are in millimeters.
 B. This drawing is subject to change without notice.
 C. Body dimensions do not include mold protrusion not to exceed 0,15.
 D. Falls within JEDEC MO-153

IMPORTANT NOTICE AND DISCLAIMER

TI PROVIDES TECHNICAL AND RELIABILITY DATA (INCLUDING DATASHEETS), DESIGN RESOURCES (INCLUDING REFERENCE DESIGNS), APPLICATION OR OTHER DESIGN ADVICE, WEB TOOLS, SAFETY INFORMATION, AND OTHER RESOURCES "AS IS" AND WITH ALL FAULTS, AND DISCLAIMS ALL WARRANTIES, EXPRESS AND IMPLIED, INCLUDING WITHOUT LIMITATION ANY IMPLIED WARRANTIES OF MERCHANTABILITY, FITNESS FOR A PARTICULAR PURPOSE OR NON-INFRINGEMENT OF THIRD PARTY INTELLECTUAL PROPERTY RIGHTS.

These resources are intended for skilled developers designing with TI products. You are solely responsible for (1) selecting the appropriate TI products for your application, (2) designing, validating and testing your application, and (3) ensuring your application meets applicable standards, and any other safety, security, regulatory or other requirements.

These resources are subject to change without notice. TI grants you permission to use these resources only for development of an application that uses the TI products described in the resource. Other reproduction and display of these resources is prohibited. No license is granted to any other TI intellectual property right or to any third party intellectual property right. TI disclaims responsibility for, and you fully indemnify TI and its representatives against any claims, damages, costs, losses, and liabilities arising out of your use of these resources.

TI's products are provided subject to [TI's Terms of Sale](#), [TI's General Quality Guidelines](#), or other applicable terms available either on ti.com or provided in conjunction with such TI products. TI's provision of these resources does not expand or otherwise alter TI's applicable warranties or warranty disclaimers for TI products. Unless TI explicitly designates a product as custom or customer-specified, TI products are standard, catalog, general purpose devices.

TI objects to and rejects any additional or different terms you may propose.

Copyright © 2026, Texas Instruments Incorporated

Last updated 10/2025