

# LMK3H0102 Reference-Less 2-Differential or 5-Single-Ended Output PCIe Gen 1-7 Compliant Programmable BAW Clock Generator

## 1 Features

- Integrated BAW resonator, no need for external reference
- Flexible frequency generation:
  - Two channel dividers: up to three unique output frequencies from 2.5MHz to 400MHz
  - LVCMOS outputs supported up to 200MHz: 1.8V, 2.5V, or 3.3V
  - Combination of AC-LVDS, DC-LVDS, LP-HCSL, and LVCMOS on OUT0 and OUT1 pins
  - Additional LVCMOS output for generation of up to 5 LVCMOS clocks
- Total output frequency stability:  $\pm 25$ ppm
- 2 functional modes: I<sup>2</sup>C or preprogrammed OTP
  - Fully configurable I<sup>2</sup>C address
- PCIe Gen 1 to Gen 7 compliant: Common Clock with or without SSC, SRNS, and SRIS
- Very low PCIe jitter with SSC:
  - PCIe Gen 3 Common Clock jitter: 135.3fs maximum (PCIe limit is 1ps)
  - PCIe Gen 4 Common Clock jitter: 135.3fs maximum (PCIe limit is 500fs)
  - PCIe Gen 5 Common Clock jitter: 57.5fs maximum (PCIe limit is 150fs)
  - PCIe Gen 6 Common Clock jitter: 34.5fs maximum (PCIe limit is 100fs)
  - PCIe Gen 7 Common Clock jitter: 29.6fs maximum (PCIe limit is 67fs)
- Programmable SSC modulation depth
  - Preprogrammed:  $-0.1\%$ ,  $-0.25\%$ ,  $-0.3\%$ , and  $-0.5\%$  down spread at 200MHz FOD frequency
  - Register programmable:  $-0.1\%$  to  $-3\%$  down spread or  $\pm 0.05\%$  to  $\pm 1.5\%$  center spread
- 1.8V to 3.3V supply voltage
- Internal LDOs with  $-93.1$ dBc PSNR at 500kHz switching noise for LP-HCSL outputs
- Start-up time:  $< 1.5$ ms
- Output-to-output skew:  $< 50$ ps
- **Fail-safe** digital input pins

## 2 Applications

- [PCIe Gen 1 to Gen 7 clock generation](#)
- [Server Motherboard](#)
- [NIC, SmartNIC](#)
- [Hardware Accelerator](#)
- [Multifunction Printer](#)
- [PCIe SSD](#)
- [Add-In Card, PCIe Expansion Card](#)

## 3 Description

The LMK3H0102 is a 2-output PCIe Gen 1 to Gen 7 compliant reference-less clock generator with Spread Spectrum Clocking (SSC) support. The part is based on TI proprietary Bulk Acoustic Wave (BAW) technology and provides  $\pm 25$ ppm clock outputs without any crystal or external clock reference. The device can provide two SSC clocks, two non-SSC clocks, or one SSC clock and one non-SSC clock at the same time. The device meets the full PCIe compliance from Gen 1 to Gen 7, including Common Clock with or without SSC, Separate Reference No Spread (SRNS), and Separate Reference Independent Spread (SRIS).

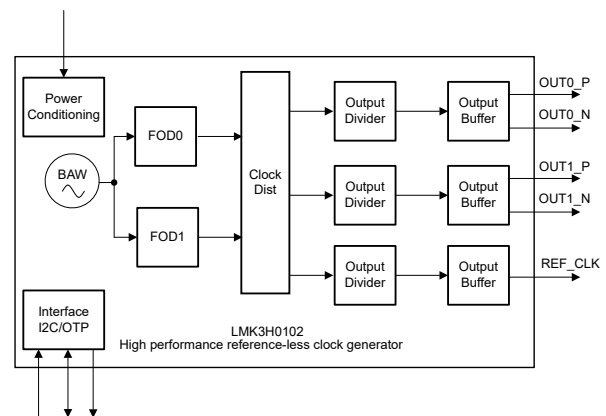
The device can be easily configured through either pins or I<sup>2</sup>C interface. An external DC/DC can be used to power the device. Refer to [Power Supply Recommendations](#) for detailed guidelines on power supply filtering and sourcing from DC/DC.

For OTP default settings for each LMK3H0102Axxx configuration, refer to the [LMK3H0102 Configuration Guide](#).

### Package Information

PART NUMBER	PACKAGE <sup>(1)</sup>	PACKAGE SIZE <sup>(2)</sup>
LMK3H0102	RER (TQFN, 16)	3.0mm × 3.0mm

- (1) For all available packages, see the section *Mechanical, Packaging, and Orderable Information*.
- (2) The package size (length × width) is a nominal value and includes pins, where applicable.

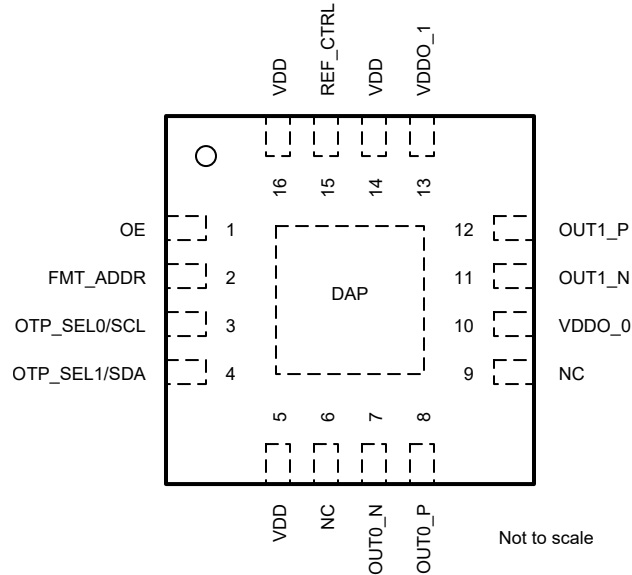


Simplified Block Diagram

## Table of Contents

<b>1 Features</b> .....	1	7.5 Programming.....	28
<b>2 Applications</b> .....	1	<b>8 Device Registers</b> .....	31
<b>3 Description</b> .....	1	8.1 Register Maps.....	31
<b>4 Pin Configuration and Functions</b> .....	3	<b>9 Application and Implementation</b> .....	41
<b>5 Specifications</b> .....	5	9.1 Application Information.....	41
5.1 Absolute Maximum Ratings.....	5	9.2 Typical Applications.....	41
5.2 ESD Ratings.....	5	9.3 Power Supply Recommendations.....	51
5.3 Recommended Operating Conditions.....	5	9.4 Layout.....	51
5.4 Thermal Information.....	6	<b>10 Device and Documentation Support</b> .....	53
5.5 Electrical Characteristics.....	6	10.1 Documentation Support.....	53
5.6 I <sup>2</sup> C Interface Specification.....	12	10.2 Receiving Notification of Documentation Updates..	53
<b>6 Parameter Measurement Information</b> .....	14	10.3 Support Resources.....	53
6.1 Output Format Configurations.....	14	10.4 Trademarks.....	53
6.2 Differential Voltage Measurement Terminology.....	15	10.5 Electrostatic Discharge Caution.....	53
<b>7 Detailed Description</b> .....	16	10.6 Glossary.....	53
7.1 Overview.....	16	<b>11 Revision History</b> .....	53
7.2 Functional Block Diagram.....	17	<b>12 Mechanical, Packaging, and Orderable Information</b> .....	55
7.3 Feature Description.....	17		
7.4 Device Functional Modes.....	21		

## 4 Pin Configuration and Functions



**Figure 4-1. LMK3H0102 16-Pin TQFN Top View**

**Table 4-1. Pin Functions**

PIN		TYPE <sup>(1)</sup>	DESCRIPTION
NAME	NO.		
OUT0_P, OUT0_N	8, 7	O	Clock output 0. Supports LP-HCSL (85Ω or 100Ω), LVDS or 1.8V, 2.5V, or 3.3V LVCMOS.
OUT1_P, OUT1_N	12, 11	O	Clock output 1. Supports LP-HCSL (85Ω or 100Ω), LVDS or 1.8V, 2.5V, or 3.3V LVCMOS.
REF_CTRL (REF_CLK)	15	I/O	Multifunctional pin. At power up, the state of this pin is latched to select the functionality of Pin 2, Pin 3 and Pin 4. Pull low or leave floating for I2C mode or high for OTP mode prior to power-up. After power-up, this pin can be programmed as an additional LVCMOS output (REF_CLK), active-high CLK_READY signal, or disabled. See <a href="#">REF_CTRL Operation</a> for more details. This pin has an 880kΩ internal pulldown resistor.
OE	1	I	Output Enable. Active low. 2-state logic input pin. This pin has a 75kΩ internal pulldown resistor. This pin can control either OUT0 alone or OUT0 and OUT1. See <a href="#">Output Enable</a> for more details. <ul style="list-style-type: none"> <li>Low/Floating: OUT0 and OUT1 enabled</li> <li>High: OUT0 and OUT1 disabled</li> </ul>
FMT_ADDR	2	I	Multifunctional pin. Functionality is determined by REF_CTRL (pin 15) at power up. See <a href="#">OTP Mode</a> and <a href="#">I2C Mode</a> for more details. This pin has an 880kΩ internal pulldown resistor. <ul style="list-style-type: none"> <li>I2C Mode: This pin can select the I2C address, function as the output enable for OUT1, or have no function.</li> <li>OTP Mode: This pin can set the output format, function as the output enable for OUT1, or have no function.</li> </ul>

**Table 4-1. Pin Functions (continued)**

PIN		TYPE <sup>(1)</sup>	DESCRIPTION
NAME	NO.		
OTP_SEL0/SCL, OTP_SEL1/SDA	3, 4	I, I/O	Multifunctional pin. Functionality is determined by REF_CTRL (pin 15) at power up. See <a href="#">OTP Mode</a> and <a href="#">I2C Mode</a> for details. These pins have 880kΩ internal pulldown resistors. <ul style="list-style-type: none"> <li>I2C Mode: These pins are the I2C clock and data connections.</li> <li>OTP Mode: These pins select the OTP page.</li> </ul>
VDD	5, 14, 16	P	1.8V, 2.5V or 3.3V device power supply. A 0.1μF capacitor must be placed as close to each of the pins as possible. For LMK3H0102V18, only provide 1.8V to this pin.
VDDO_0, VDDO_1	10, 13	P	1.8V, 2.5V or 3.3V OUT0 and OUT1 power supply. If VDD is 1.8V or 2.5V, the VDDO pins must be the same voltage as VDD. A 0.1μF capacitor must be placed as close to each of the pins as possible. When using split power supply, see <a href="#">Power-Up Sequencing</a> for proper implementation.
NC	6, 9	N/A	No connect. Pins can be connected to GND, VDD, or otherwise tied to any potential within the Supply Voltage range stated in the <a href="#">Absolute Maximum Ratings</a> .
DAP	17	G	GND

(1) I = Input, O = Output, I/O = Input or Output, G = Ground, P = Power.

## 5 Specifications

### 5.1 Absolute Maximum Ratings

over operating free-air temperature range (unless otherwise noted)<sup>(1)</sup>

		MIN	MAX	UNIT
V <sub>DD</sub>	Device supply voltage	-0.3	3.9	V
V <sub>DDO</sub>	Output supply voltage	-0.3	3.9	V
V <sub>IN</sub>	Logic input voltage (V <sub>DD</sub> = V <sub>DDO</sub> = -0.3V to -3.9V)	-0.3	3.9	V
V <sub>OUT</sub>	Voltage applied to OUTx_P and OUTx_N pins (when outputs are high or low)	-0.3	V <sub>DDO,x</sub> + 0.3	V
	Voltage applied to OUTx_P and OUTx_N pins (when outputs are LVCMOS tri-state)	-0.3	1.89	V
	Voltage applied to OUTx_P and OUTx_N pins (when outputs are LP-HCSL or LVDS tri-state)	-0.3	1.5	V
T <sub>J</sub>	Junction temperature		105	°C

- (1) Operation outside the Absolute Maximum Ratings may cause permanent device damage. Absolute Maximum Ratings do not imply functional operation of the device at these or any other conditions beyond those listed under Recommended Operating Conditions. If used outside the Recommended Operating Conditions but within the Absolute Maximum Ratings, the device may not be fully functional, and this may affect device reliability, functionality, performance, and shorten the device lifetime.

### 5.2 ESD Ratings

			VALUE	UNIT
V <sub>(ESD)</sub>	Electrostatic discharge	Human body model (HBM), per ANSI/ESDA/ JEDEC JS-001, all pins <sup>(1)</sup>	±2000	V
		Charged device model (CDM), per JEDEC specification JS-002, all pins <sup>(2)</sup>	±500	

- (1) JEDEC document JEP155 states that 500V HBM allows safe manufacturing with a standard ESD control process.  
 (2) JEDEC document JEP157 states that 250V CDM allows safe manufacturing with a standard ESD control process.

### 5.3 Recommended Operating Conditions

V<sub>DD</sub> = V<sub>DDO</sub> = 1.8V, 2.5V or 3.3V ± 5%, T<sub>A</sub> = T<sub>A,min</sub> to T<sub>A,max</sub>

		MIN	NOM	MAX	UNIT
V <sub>DD</sub>	Device supply voltage	1.71	1.8	1.89	V
		2.375	2.5	2.625	V
		3.135	3.3	3.465	V
V <sub>DDO</sub>	Output supply voltage	1.71	1.8	1.89	V
		2.375	2.5	2.625	V
		3.135	3.3	3.465	V
T <sub>A</sub>	Ambient temperature	-40		85	°C
T <sub>J</sub>	Junction temperature	-40		105	°C
t <sub>ramp</sub>	Power supply ramp time. V <sub>DD</sub> = 1.8V	0.05		5	ms
t <sub>ramp</sub>	Power supply ramp time. V <sub>DD</sub> = 2.5V or 3.3V	0.05		5	ms

### 5.4 Thermal Information

THERMAL METRIC <sup>(1)</sup>		LMK3H0102	
		RER (QFN)	
		16 PINS	
			UNIT
R <sub>θJA</sub>	Junction-to-ambient thermal resistance	69.8	°C/W
R <sub>θJC(top)</sub>	Junction-to-case (top) thermal resistance	56.5	°C/W
R <sub>θJB</sub>	Junction-to-board thermal resistance	38.6	°C/W
Ψ <sub>JT</sub>	Junction-to-top characterization parameter	2.1	°C/W
Ψ <sub>JB</sub>	Junction-to-board characterization parameter	38.5	°C/W
R <sub>θJC(bot)</sub>	Junction-to-case (bottom) thermal resistance	10.3	°C/W

(1) For more information about traditional and new thermal metrics, see the [Semiconductor and IC Thermal Metrics](#) application note.

### 5.5 Electrical Characteristics

V<sub>DD</sub> = V<sub>DDO</sub> = 1.8V, 2.5V or 3.3V ± 5%, T<sub>A</sub> = T<sub>A,min</sub> to T<sub>A,max</sub>

PARAMETER		TEST CONDITIONS	MIN	TYP	MAX	UNIT
<b>FREQUENCY STABILITY</b>						
Δf <sub>total</sub>	Total frequency stability	All factors included: temperature variation, 10-year aging at 25°C, solder shift, hysteresis and initial frequency accuracy	-25		25	ppm
<b>LP-HCSL CLOCK OUTPUT CHARACTERISTICS</b>						
f <sub>out</sub>	Output frequency		2.5		400	MHz
V <sub>min</sub>	Output low voltage (undershoot included)		-60		25	mV
V <sub>overshoot</sub>	Overshoot voltage. V <sub>max</sub> - V <sub>OH</sub>				150	mV
V <sub>OH,2.5/3.3</sub>	Output high voltage. VDD = 2.5V or 3.3V	code = 0	563	625	688	mV
		code = 1	582	647	712	mV
		code = 2	601	668	735	mV
		code = 3	621	690	759	mV
		code = 4	641	712	783	mV
		code = 5	660	733	806	mV
		code = 6 (default)	680	755	831	mV
		code = 7	699	777	855	mV
		code = 8	718	798	878	mV
		code = 9	738	820	902	mV
		code = 10	758	842	926	mV
		code = 11	777	863	949	mV
		code = 12	797	885	974	mV
		code = 13	816	907	998	mV
		code = 14	835	928	1021	mV
code = 15	855	950	1045	mV		

$V_{DD} = V_{DDO} = 1.8V, 2.5V \text{ or } 3.3V \pm 5\%, T_A = T_{A,min} \text{ to } T_{A,max}$ 

PARAMETER		TEST CONDITIONS	MIN	TYP	MAX	UNIT
V <sub>OH,1.8</sub>	Output high voltage. VDD = 1.8V	code = 0	563	625	688	mV
		code = 1	582	647	712	mV
		code = 2	601	668	735	mV
		code = 3	621	690	759	mV
		code = 4	641	712	783	mV
		code = 5	660	733	806	mV
		code = 6 (default)	680	755	831	mV
		code = 7	699	777	855	mV
		code = 8	718	798	878	mV
		code = 9	738	820	902	mV
		code = 10	758	842	926	mV
		code = 11	777	863	949	mV
		code = 12	797	885	974	mV
		code = 13	816	907	998	mV
		code = 14	835	928	1021	mV
	code = 15	855	950	1045	mV	
Z <sub>diff</sub>	LP-HCSL static differential impedance		80.75	85	91.25	Ω
			95	100	105	Ω
dV/dt	Output slew rate (rising and falling edge)	Measured from –150mV to +150mV on the differential waveform, centered on the zero crossing point. OUTx_SLEW_RATE = 0 <sup>(1)</sup>	2.1		3.1	V/ns
		Measured from –150mV to +150mV on the differential waveform, centered on the zero crossing point. OUTx_SLEW_RATE = 0	2.3		3.5	V/ns
		Measured from –150mV to +150mV on the differential waveform, centered on the zero crossing point. OUTx_SLEW_RATE = 1	2		3.2	V/ns
		Measured from –150mV to +150mV on the differential waveform, centered on the zero crossing point. OUTx_SLEW_RATE = 2	1.7		2.8	V/ns
		Measured from –150mV to +150mV on the differential waveform, centered on the zero crossing point. OUTx_SLEW_RATE = 3	1.4		2.7	V/ns
ΔdV/dt	Rising edge rate to falling edge rate matching	See <sup>(1)</sup>		3	%	
ODC	Output duty cycle	See <sup>(1)</sup>	47		53	%
		f <sub>out</sub> ≤ 325MHz	47		53	%
		325MHz < f <sub>out</sub> ≤ 400MHz	47		53	%
t <sub>skew</sub>	Output to output skew	Same FOD, LP-HCSL output		50	ps	
V <sub>cross</sub>	Absolute crossing point voltage	See <sup>(1)</sup>	280		480	mV
ΔV <sub>cross</sub>	Variation of V <sub>cross</sub> over all clock edges	See <sup>(1)</sup>			30	mV
V <sub>RB</sub>	Absolute value of ring back voltage	See <sup>(1)</sup>	100			mV
t <sub>stable</sub>	Time before V <sub>RB</sub> is allowed	See <sup>(1)</sup>	500			ps
J <sub>cycle-to-cycle</sub>	Cycle to cycle jitter, Common Clock no SSC	See <sup>(1)</sup>			20	ps

**LMK3H0102**

SNAS847E – NOVEMBER 2023 – REVISED OCTOBER 2025

 $V_{DD} = V_{DDO} = 1.8V, 2.5V \text{ or } 3.3V \pm 5\%$ ,  $T_A = T_{A,min} \text{ to } T_{A,max}$ 

PARAMETER		TEST CONDITIONS	MIN	TYP	MAX	UNIT
$J_{\text{cycle-to-cycle}}$	Cycle to cycle jitter, Common Clock, – 0.5% SSC	See <sup>(1)</sup>			25	ps
$t_{\text{period\_abs}}$	Absolute period including jitter and SSC	See <sup>(1)</sup>	9.949	10	10.101	ns
$t_{\text{period\_avg\_CC}}$	Average clock period accuracy, Common Clock	See <sup>(1)</sup>	–100		2600	ppm
$t_{\text{period\_avg\_SRIS}}$	Average clock period accuracy, SRIS	See <sup>(1)</sup>	–100		1600	ppm
<b>LVDS CLOCK OUTPUT CHARACTERISTICS</b>						
$f_{\text{out}}$	Output frequency		2.5		400	MHz
$ V_{\text{od}} $	Steady-state magnitude of the differential output voltage $ V_{\text{OUTP}} - V_{\text{OUTN}} $	100Ω external termination	250	350	450	mV
$\Delta V_{\text{pp-diff}}$	Change in differential output voltage swing between complementary output states	100Ω external termination			50	mV
$V_{\text{OS}}$	Output offset voltage (common mode voltage)	$V_{\text{DDO}} = 3.3V$ , 100Ω external termination	1.12	1.2	1.365	V
		$V_{\text{DDO}} = 2.5V$ , 100Ω external termination	1.1	1.2	1.345	V
		$V_{\text{DDO}} = 1.8V$ , 100Ω external termination	0.8		0.97	V
$\Delta V_{\text{OS}}$	Change in $V_{\text{OS}}$ between complementary output states				50	mV
$I_{\text{SA}}, I_{\text{SB}}$	Short-circuit current. Magnitude of current with the generator output terminals short-circuited to the generator circuit common		–24		24	mA
$I_{\text{SAB}}$	Short-circuit current. Magnitude of current with generator output terminals short-circuited to each other		–12		12	mA
$t_{\text{R}}, t_{\text{F}}$	20% to 80% differential rise/fall time	OUTx_SLEW_RATE = 0	195		323	ps
		OUTx_SLEW_RATE = 1	250		454	ps
		OUTx_SLEW_RATE = 2	270		635	ps
		OUTx_SLEW_RATE = 3	280		792	ps
$t_{\text{skew}}$	Output to output skew	Same FOD, LVDS output			50	ps
ODC	Output duty cycle		47		53	%
<b>LVC MOS CLOCK OUTPUT CHARACTERISTICS</b>						
$f_{\text{out}}$	Output frequency		2.5		200	MHz
$dV/dt$	Output slew rate	$V_{\text{DDO}} = 3.3V \pm 5\%$ , measured from 20% to 80%, 4.7pF load	2.6		4.7	V/ns
		$V_{\text{DDO}} = 2.5V \pm 5\%$ , measured from 20% to 80%, 4.7pF load	2.6		3.7	V/ns
		$V_{\text{DDO}} = 1.8V \pm 5\%$ , measured from 20% to 80%, 4.7pF load	1.5		3.2	V/ns
$V_{\text{OH}}$	Output high voltage	$I_{\text{OH}} = -15\text{mA}$ at 3.3V	$0.8 \times V_{\text{DDO}}$		$V_{\text{DDO}}$	V
		$I_{\text{OH}} = -12\text{mA}$ at 2.5V				
		$I_{\text{OH}} = -8\text{mA}$ at 1.8V				
$V_{\text{OL}}$	Output low voltage	$I_{\text{OL}} = 15\text{mA}$ at 3.3V			0.4	V
		$I_{\text{OL}} = 12\text{mA}$ at 2.5V				
		$I_{\text{OL}} = 8\text{mA}$ at 1.8V				
$I_{\text{leak}}$	Output leakage current	Output tri-stated. $V_{\text{DD}} = V_{\text{DDO}} = 3.465V$	–5	0	5	μA
$R_{\text{out}}$	Output impedance			17		Ω
ODC	Output duty cycle	$f_{\text{out}} \leq 156.25\text{MHz}$	45		55	%
		$f_{\text{out}} > 156.25\text{MHz}$	40		60	%



$V_{DD} = V_{DDO} = 1.8V, 2.5V \text{ or } 3.3V \pm 5\%, T_A = T_{A,min} \text{ to } T_{A,max}$ 

PARAMETER		TEST CONDITIONS	MIN	TYP	MAX	UNIT
$t_{skew}$	Output-to-output skew	Same FOD, LVCMOS output			50	ps
$C_{load}$	Maximum load capacitance				15	pF
<b>LVCMOS REFCLK CHARACTERISTICS</b>						
$f_{out}$	Output frequency	See <sup>(2)</sup>	12.5 <sup>(3)</sup>		200	MHz
dV/dt	Output slew rate	$V_{DDO} = 3.3V \pm 5\%$ , measured from 20% to 80%, 4.7pF load <sup>(2)</sup>	2.6		6.7	V/ns
		$V_{DDO} = 2.5V \pm 5\%$ , measured from 20% to 80%, 4.7pF load <sup>(2)</sup>	1.8		4.5	V/ns
		$V_{DDO} = 1.8V \pm 5\%$ , measured from 20% to 80%, 4.7pF load <sup>(2)</sup>	1		3.2	V/ns
$I_{leak}$	Output leakage current	Output in tri-state condition. $V_{DD} = V_{DDO} = 3.465V$ <sup>(2)</sup>	-5		5	$\mu A$
$R_{out}$	Output impedance			17		$\Omega$
ODC	Output duty cycle	$f_{out} \leq 156.25MHz$ <sup>(2)</sup>	45		55	%
ODC	Output duty cycle	$f_{out} > 156.25MHz$ <sup>(2)</sup>	40		60	%
$C_{load}$	Maximum load capacitance	See <sup>(2)</sup>			15	pF
RJ	Random jitter	12kHz to 20MHz integrated jitter at 50MHz <sup>(2)</sup>			0.5	ps
<b>SSC CHARACTERISTICS</b>						
$f_{out}$	Output frequency range that supports SSC (any output format)		2.5		200	MHz
$f_{SSC}$	SSC modulation frequency		30	31.5	33	kHz
$f_{SSC\text{-}deviation}$	SSC deviation (modulation depth)	Down spread (programmable)	-3		-0.1	%
		Center spread (programmable)	$\pm 0.05$		$\pm 1.5$	%
$f_{SSC\text{-}deviation\text{-}accuracy}$	SSC deviation accuracy	$f_{out} \leq 100MHz$ , down spread	0		0.01	%
		$100MHz < f_{out} \leq 200MHz$ , down spread	0		0.05	%
		$f_{out} \leq 100MHz$ , center spread	0		0.01	%
		$100MHz < f_{out} \leq 200MHz$ , center spread	0		0.05	%
df/dt	max SSC frequency slew rate	$0 < f_{SSC\text{-}deviation} \leq -0.5\%$			1250	ppm/ $\mu s$
<b>JITTER CHARACTERISTICS</b>						
$J_{PCle1\text{-}cc\text{-}SSC\_off}$	PCIe Gen 1 Common Clock jitter, SSC is off (jitter limit = 86ps)	SSC disabled on both outputs			0.8	ps
$J_{PCle1\text{-}cc\text{-}SSC\_on}$	PCIe Gen 1 Common Clock jitter, $-0.5\% \leq SSC < 0\%$ (jitter limit = 86ps)	SSC enabled on both outputs			1.4	ps
$J_{PCle2\text{-}cc\text{-}SSC\_off}$	PCIe Gen 2 Common Clock jitter, SSC is off (jitter limit = 3ps)	SSC disabled on both outputs		0.2	0.3	ps
$J_{PCle2\text{-}cc\text{-}SSC\_on}$	PCIe Gen 2 Common Clock jitter, $-0.5\% \leq SSC < 0\%$ (jitter limit = 3ps)	SSC enabled on both outputs		0.3	0.5	ps
$J_{PCle2\text{-}SRNS}$	PCIe Gen 2 SRNS jitter	SSC disabled on both outputs		0.2	0.3	ps
$J_{PCle2\text{-}SRIS}$	PCIe Gen 2 SRIS jitter, $-0.3\% \leq SSC < 0\%$	SSC enabled on both outputs		0.3	0.5	ps
$J_{PCle3\text{-}cc\text{-}SSC\_off}$	PCIe Gen 3 Common Clock jitter, SSC is off (jitter limit = 1ps)	SSC disabled on both outputs		42.8	84.2	fs
$J_{PCle3\text{-}cc\text{-}SSC\_on}$	PCIe Gen 3 Common Clock jitter, $-0.5\% \leq SSC < 0\%$ (jitter limit = 1ps)	SSC enabled on both outputs		63.1	135.3	fs
$J_{PCle3\text{-}SRNS}$	PCIe Gen 3 SRNS jitter	SSC disabled on both outputs		48.8	97.5	fs
$J_{PCle3\text{-}SRIS}$	PCIe Gen 3 SRIS jitter, $-0.3\% \leq SSC < 0\%$	SSC enabled on both outputs		194.1	418.5	fs

**LMK3H0102**

SNAS847E – NOVEMBER 2023 – REVISED OCTOBER 2025

 $V_{DD} = V_{DDO} = 1.8V, 2.5V \text{ or } 3.3V \pm 5\%$ ,  $T_A = T_{A,min} \text{ to } T_{A,max}$ 

PARAMETER		TEST CONDITIONS	MIN	TYP	MAX	UNIT
J <sub>PCle4-cc-SSC_off</sub>	PCIe Gen 4 Common Clock jitter, SSC is off (jitter limit = 500fs)	SSC disabled on both outputs		42.8	84.2	fs
J <sub>PCle4-cc-SSC_on</sub>	PCIe Gen 4 Common Clock jitter, $-0.5\% \leq \text{SSC} < 0\%$ (jitter limit = 500fs)	SSC enabled on both outputs		63.1	135.3	fs
J <sub>PCle4-SRNS</sub>	PCIe Gen 4 SRNS jitter	SSC disabled on both outputs		48.8	97.5	fs
J <sub>PCle4-SRIS</sub>	PCIe Gen 4 SRIS jitter, $-0.3\% \leq \text{SSC} < 0\%$	SSC enabled on both outputs		98.5	205.4	fs
J <sub>PCle5-cc-SSC_off</sub>	PCIe Gen 5 Common Clock jitter, SSC is off (jitter limit = 150fs)	SSC disabled on both outputs		17.8	35.6	fs
J <sub>PCle5-cc-SSC_on</sub>	PCIe Gen 5 Common Clock jitter, $-0.5\% \leq \text{SSC} < 0\%$ (jitter limit = 150fs)	SSC enabled on both outputs		26.4	57.5	fs
J <sub>PCle5-SRNS</sub>	PCIe Gen 5 SRNS jitter	SSC disabled on both outputs		19.8	39	fs
J <sub>PCle5-SRIS</sub>	PCIe Gen 5 SRIS jitter, $-0.3\% \leq \text{SSC} < 0\%$	SSC enabled on both outputs		30.2	63.9	fs
J <sub>PCle6-cc-SSC_off</sub>	PCIe Gen 6 Common Clock jitter, SSC is off (jitter limit = 100fs)	SSC disabled on both outputs		11	22	fs
J <sub>PCle6-cc-SSC_on</sub>	PCIe Gen 6 Common Clock jitter, $-0.5\% \leq \text{SSC} < 0\%$ (jitter limit = 100fs)	SSC enabled on both outputs		16	34.5	fs
J <sub>PCle6-SRNS</sub>	PCIe Gen 6 SRNS jitter	SSC disabled on both outputs		14.8	27.9	fs
J <sub>PCle6-SRIS</sub>	PCIe Gen 6 SRIS jitter, $-0.3\% \leq \text{SSC} < 0\%$	SSC enabled on both outputs		22.2	45.9	fs
J <sub>PCle7-cc-SSC_off</sub>	PCIe Gen 7 Common Clock jitter, SSC is off (jitter limit = 67fs)	SSC disabled on both outputs		7.7	15.4	fs
J <sub>PCle7-cc-SSC_on</sub>	PCIe Gen 7 Common Clock jitter, $-0.5\% \leq \text{SSC} < 0\%$ (jitter limit = 67fs)	SSC enabled on both outputs		12.1	29.6	fs
J <sub>PCle7-SRNS</sub>	PCIe Gen 7 SRNS jitter	SSC disabled on both outputs		10.4	19.6	fs
J <sub>PCle7-SRIS</sub>	PCIe Gen 7 SRIS jitter, $-0.1\% \leq \text{SSC} < 0\%$	SSC enabled on both outputs		12.2	25.5	fs
R <sub>JRMS</sub>	12kHz to 20MHz RMS jitter	$f_{out} = 156.25\text{MHz}$		105	144	fs
<b>TIMING CHARACTERISTICS</b>						
t <sub>startup</sub>	Start-up time	V <sub>DD</sub> = 2.5V or 3.3V. Time elapsed from all V <sub>DD</sub> pins reach 2.1V until first output clock rising edge. Output clock is always within specification			1	ms
		V <sub>DD</sub> = 1.8V. Time elapsed from all V <sub>DD</sub> pins reach 1.6V until first output clock rising edge. Output clock is always within specification			1.5	ms
t <sub>OE</sub>	Output enable time.	After CLOCK_READY status is '1', time elapsed between OE assertion and first output clock rising edge. Output is not tristated when disabled.			7	output clock cycles
t <sub>OD</sub>	Output disable time.	Time elapsed between OE deassertion and last output clock falling edge.			7	output clock cycles
<b>POWER CONSUMPTION CHARACTERISTICS</b>						

$V_{DD} = V_{DDO} = 1.8V, 2.5V$  or  $3.3V \pm 5\%$ ,  $T_A = T_{A,min}$  to  $T_{A,max}$

PARAMETER		TEST CONDITIONS	MIN	TYP	MAX	UNIT
$I_{DD}$	Core supply current, not including output drivers	One FOD enabled, $100MHz \leq f_{FOD} \leq 200MHz$		57.5	79.9	mA
		One FOD enabled, $200MHz < f_{FOD} \leq 400MHz$		67	90.7	mA
		Two FODs enabled, $100MHz \leq f_{FOD} \leq 200MHz$		81.1	105.8	mA
		Two FODs enabled, $200MHz < f_{FOD} \leq 400MHz$		97.8	125.8	mA
$I_{DDO}$	Output supply current, per output channel	LP-HCSL. $f_{out} \leq 100MHz$		10.1	10.8	mA
		LP-HCSL. $100MHz < f_{out} \leq 200MHz$		13.2	14.1	mA
		LP-HCSL. $200MHz < f_{out} \leq 300MHz$		13.7	15.1	mA
		LP-HCSL. $300MHz < f_{out} \leq 400MHz$		14.4	16.4	mA
		LVDS. $f_{out} \leq 100MHz$		6	8	mA
		LVDS. $100MHz < f_{out} \leq 200MHz$		6.8	9.2	mA
		LVDS. $200MHz < f_{out} \leq 300MHz$		7.6	10.2	mA
		LVDS. $300MHz < f_{out} \leq 400MHz$		8.4	11.3	mA
		1.8V LVCMOS. $f_{out} = 50MHz^{(4)}$		4.2	5	mA
		1.8V LVCMOS. $f_{out} = 200MHz^{(4)}$		11.7	13.4	mA
		2.5V LVCMOS. $f_{out} = 50MHz^{(4)}$		5.6	6.4	mA
		2.5V LVCMOS. $f_{out} = 200MHz^{(4)}$		15.3	17.3	mA
		3.3V LVCMOS. $f_{out} = 50MHz^{(4)}$		6.8	7.7	mA
		3.3V LVCMOS. $f_{out} = 200MHz^{(4)}$		19.2	21.7	mA
$I_{DDREF}$	REFCLK supply current	1.8V LVCMOS. $f_{out} = 50MHz^{(4)}$		3.4	3.9	mA
		1.8V LVCMOS. $f_{out} = 200MHz^{(4)}$		9.5	11.7	mA
		2.5V LVCMOS. $f_{out} = 50MHz^{(4)}$		4.7	5.3	mA
		2.5V LVCMOS. $f_{out} = 200MHz^{(4)}$		12.8	15.8	mA
		3.3V LVCMOS. $f_{out} = 50MHz^{(4)}$		5.9	6.6	mA
		3.3V LVCMOS. $f_{out} = 200MHz^{(4)}$		16.6	20.2	mA
<b>PSNR CHARACTERISTICS</b>						
$PSNR_{LVC MOS}$	Power Supply Noise Rejection for LVCMOS outputs <sup>(5)</sup>	10kHz		-76.7	-58.1	dBc
		50kHz		-80.9	-57.9	dBc
		100kHz		-81.8	-57	dBc
		500kHz		-84.3	-61.7	dBc
		1MHz		-97.6	-78.1	dBc
		5MHz		-104.3	-79	dBc
		10MHz		-108.7	-89.5	dBc
$PSNR_{LVDS}$	Power Supply Noise Rejection for LVDS outputs <sup>(5)</sup>	10kHz		-79.5	-70.9	dBc
		50kHz		-83.5	-73.2	dBc
		100kHz		-83	-71.6	dBc
		500kHz		-88.3	-79	dBc
		1MHz		-123.4	-101.4	dBc
		5MHz		-115	-87.7	dBc
		10MHz		-123.7	-103.5	dBc

**LMK3H0102**

SNAS847E – NOVEMBER 2023 – REVISED OCTOBER 2025

 $V_{DD} = V_{DDO} = 1.8V, 2.5V \text{ or } 3.3V \pm 5\%$ ,  $T_A = T_{A,min} \text{ to } T_{A,max}$ 

PARAMETER		TEST CONDITIONS	MIN	TYP	MAX	UNIT
PSNR <sub>LP-HCSL</sub>	Power Supply Noise Rejection for LP-HCSL outputs <sup>(5)</sup>	10kHz		-80.1	-70.8	dBc
		50kHz		-84.7	-72.9	dBc
		100kHz		-84.6	-70.1	dBc
		500kHz		-93.1	-78.8	dBc
		1MHz		-124.6	-101.5	dBc
		5MHz		-114.3	-88.3	dBc
		10MHz		-123	-103.7	dBc
<b>2-STATE LOGIC INPUT CHARACTERISTICS</b>						
V <sub>IH-Pin2</sub>	Input high voltage for Pin 2		0.7 × V <sub>DD</sub>		V <sub>DD</sub> + 0.3	V
V <sub>IL-Pin2</sub>	Input low voltage for Pin 2		GND – 0.3		0.3 × V <sub>DD</sub>	V
V <sub>IH-Pin1</sub>	Input high voltage for Pin 1		1.15		V <sub>DD</sub> + 0.3	V
V <sub>IL-Pin1</sub>	Input low voltage for Pin 1		-0.3		0.65	V
V <sub>IH-Pin3,4</sub>	Input voltage high for OTP_SEL[1:0]		0.7 × V <sub>DD</sub>		V <sub>DD</sub> + 0.3	V
V <sub>IL-Pin3,4</sub>	Input voltage low for OTP_SEL[1:0]		GND - 0.3		0.8	V
V <sub>IH-Pin15</sub>	Input voltage high for Pin 15		0.65 × V <sub>DD</sub>		V <sub>DD</sub> + 0.3	V
V <sub>IL-Pin15</sub>	Input voltage low for Pin 15		-0.3		0.4	V
R <sub>ext-up/down-Pin1,2</sub>	Recommended external pullup or pulldown resistor for Pin 1, 2		0	1	10	kΩ
R <sub>ext-up/down-Pin3,4,15</sub>	Recommended external pullup or pulldown resistor for Pin 3, 4, 15		0	10	60	kΩ
t <sub>R</sub> /t <sub>F</sub>	OE signal rise or fall time				10	ns
C <sub>in</sub>	Input capacitance				3	pF

 (1) PCIe test load, 15dB loss at 4GHz, f<sub>out</sub> = 100MHz, Z<sub>diff</sub> = 100Ω

(2) Tested with 10kΩ external pullup or pulldown resistor

(3) REFCLK can be /2, /4, /8 from either FOD0 or FOD1. Both FODs support 100MHz to 400MHz.

(4) 4.7pF capacitive load with a 5in trace

(5) All power supply pins are tied together. 0.1μF capacitor placed close to each power supply pin. Apply 50mVpp ripple and measure the spur level at the clock output

## 5.6 I<sup>2</sup>C Interface Specification

 All timing requirements referred to V<sub>IH-min</sub> and V<sub>IL-max</sub>. Chip V<sub>DD</sub> = I<sup>2</sup>C V<sub>DD</sub>.

PARAMETER		TEST CONDITIONS	STANDARD MODE		FAST MODE		UNIT
			MIN	MAX	MIN	MAX	
V <sub>IL</sub>	Input low voltage		-0.3	0.3 × V <sub>DD</sub>	-0.3	0.3 × V <sub>DD</sub>	V
V <sub>IH</sub>	Input high voltage		0.7 × V <sub>DD</sub>	V <sub>DD</sub> + 0.3	0.7 × V <sub>DD</sub>	V <sub>DD</sub> + 0.3	V
V <sub>hys</sub>	Hysteresis of Schmitt trigger input				0.05 × V <sub>DD</sub>		V
V <sub>OL1</sub>	Low level output voltage 1	At 3mA sink current. V <sub>DD</sub> > 2V	0	0.4	0	0.4	V
V <sub>OL2</sub>	Low level output voltage 2	At 2mA sink current. V <sub>DD</sub> ≤ 2V			0	0.2 × V <sub>DD</sub>	V

All timing requirements referred to  $V_{IH-min}$  and  $V_{IL-max}$ . Chip  $V_{DD} = I^2C V_{DD}$ .

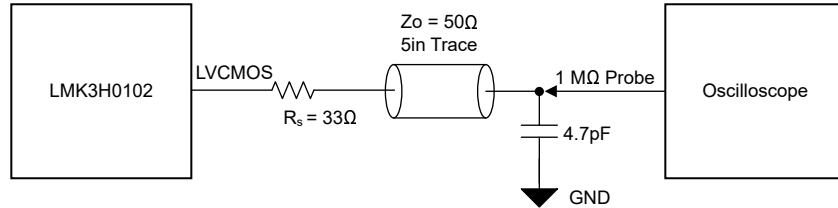
PARAMETER		TEST CONDITIONS	STANDARD MODE		FAST MODE		UNIT
			MIN	MAX	MIN	MAX	
$I_{OL}$	Low level output current	$V_{OL} = 0.4V$	3		3		mA
		$V_{OL} = 0.6V$			6		mA
$t_{OF}$	Output fall time from $V_{IHmin}$ to $V_{ILmax}$			250	$20 \times (V_{DD} / 5.5V)$	250	ns
$t_{SP}$	Pulse width of spikes that must be suppressed by the input filter				0	50	ns
$I_i$	Input current each I/O pin	$0.1 \times V_{DD} < V_{IN} < 0.9 \times V_{DDmax}$	-10	10	-10	10	$\mu A$
$C_i$	Capacitance for each I/O pin			10		10	pF
$f_{SCL}$	SCL clock frequency		0	100	0	400	kHz
$t_{HD-STA}$	Hold time (repeated) START condition	After this period, the first clock pulse is generated	4		0.6		$\mu s$
$t_{low}$	Low period of the SCL clock		4.7		1.3		$\mu s$
$t_{high}$	High period of the SCL clock		4		0.6		$\mu s$
$t_{SU-STA}$	Set-up time for a repeated START condition		4.7		0.6		$\mu s$
$t_{HD-DAT}$	Data hold time	I <sup>2</sup> C bus devices	0		0		$\mu s$
$t_{SU-DAT}$	Data set-up time		0.25		0.1		$\mu s$
$t_R$	Rise time of both SDA and SCL signals <sup>(1)</sup>			300	20	300	ns
$t_F$	Fall time of both SDA and SCL signals <sup>(1)</sup>			300	$20 \times (V_{DD} / 5.5V)$	300	ns
$t_{SU-STO}$	Set-up time for STOP condition		4		0.6		$\mu s$
$t_{BUF}$	Bus free time between a STOP and START condition		4.7		1.3		$\mu s$
$C_B$	Capacitive load for each bus line			400		400	pF
$t_{VD-DAT}$	Data valid time			3.45		0.9	$\mu s$
$t_{VD-ACK}$	Data valid acknowledge time			3.45		0.9	$\mu s$
$V_{NL}$	Noise margin at the low level	For each connected device, including hysteresis	$0.1 \times V_{DD}$		$0.1 \times V_{DD}$		V
$V_{NH}$	Noise margin at the high level	For each connected device, including hysteresis	$0.2 \times V_{DD}$		$0.2 \times V_{DD}$		V

(1) Rise and fall time parameters vary depending on the characteristics of IO driver, pullup resistor value, and total capacitance on the trace

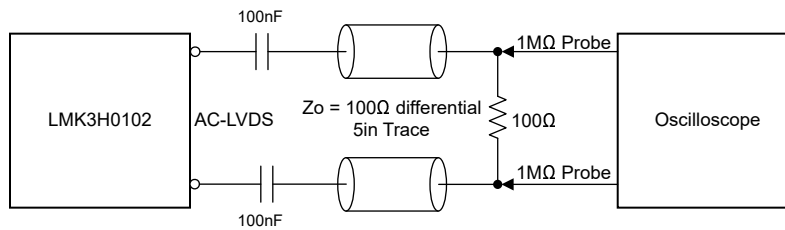
## 6 Parameter Measurement Information

### 6.1 Output Format Configurations

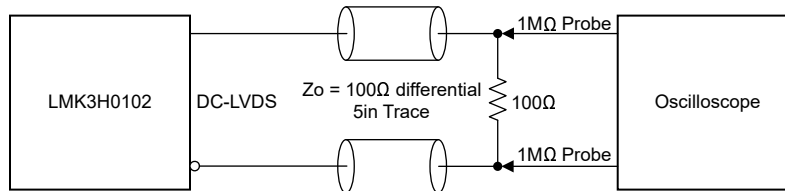
This section describes the characterization test setup of each output format option in the LMK3H0102.



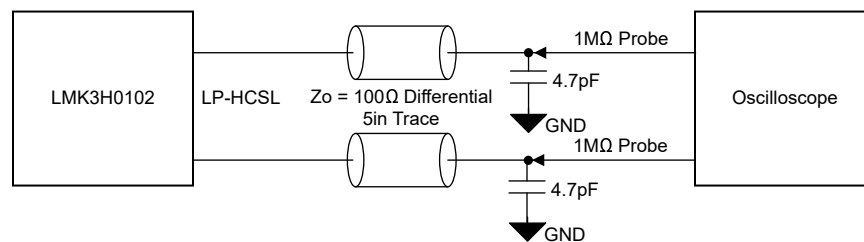
**Figure 6-1. LVC MOS Output Configuration During Device Test**



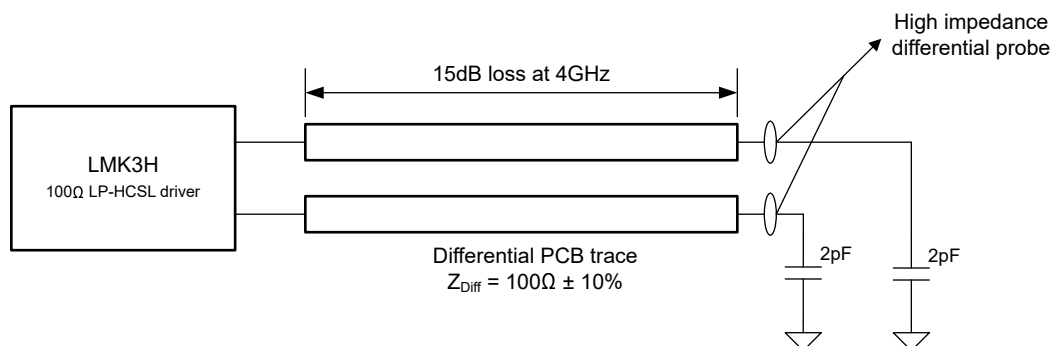
**Figure 6-2. AC-LVDS Output Configuration During Device Test**



**Figure 6-3. DC-LVDS Output Configuration During Device Test**



**Figure 6-4. LP-HCSL Output Configuration During Non-PCIe Device Test**



**Figure 6-5. LP-HCSL Output Configuration During PCIe Device Test**

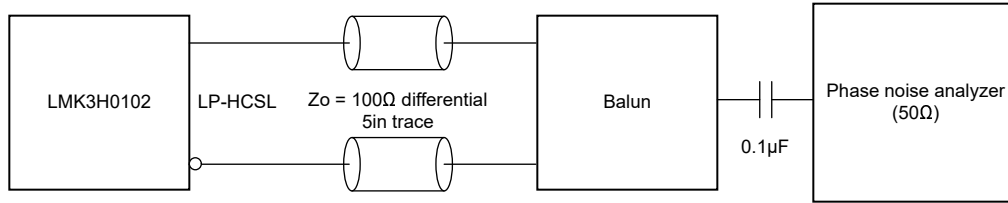


Figure 6-6. PCIe Test Configuration Using Phase Noise Analyzer

## 6.2 Differential Voltage Measurement Terminology

The differential voltage of a differential signal can be described by two different definitions, causing confusion when reading data sheets or communicating with other engineers. This section addresses the measurement and description of a differential signal so that the reader is able to understand and distinguish between the two different definitions when used.

The first definition used to describe a differential signal is the absolute value of the voltage potential between the inverting and noninverting signal. The symbol for this first measurement is typically  $V_{ID}$  or  $V_{OD}$  depending on if an input or output voltage is being described.

The second definition used to describe a differential signal is to measure the potential of the noninverting signal with respect to the inverting signal. The symbol for this second measurement is  $V_{SS}$  and is a calculated parameter. Nowhere in the IC does this signal exist with respect to ground, the signal only exists in reference to the differential pair.  $V_{SS}$  can be measured directly by oscilloscopes with floating references, otherwise this value can be calculated as twice the value of  $V_{OD}$  as described in the first description.

Figure 6-7 shows the two different definitions side-by-side for inputs and Figure 6-8 shows the two different definitions side-by-side for outputs. The  $V_{ID}$  and  $V_{OD}$  definitions show  $V_A$  and  $V_B$  DC levels that the noninverting and inverting signals toggle between with respect to ground.  $V_{SS}$  input and output definitions show that if the inverting signal is considered the voltage potential reference, the noninverting signal voltage potential is now increasing and decreasing above and below the noninverting reference. Thus the peak-to-peak voltage of the differential signal can be measured.

$V_{ID}$  and  $V_{OD}$  are often defined as volts (V) and  $V_{SS}$  is often defined as volts peak-to-peak ( $V_{PP}$ ).

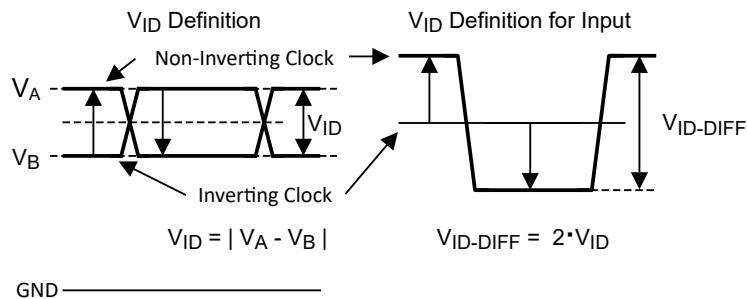


Figure 6-7. Two Different Definitions for Differential Input Signals

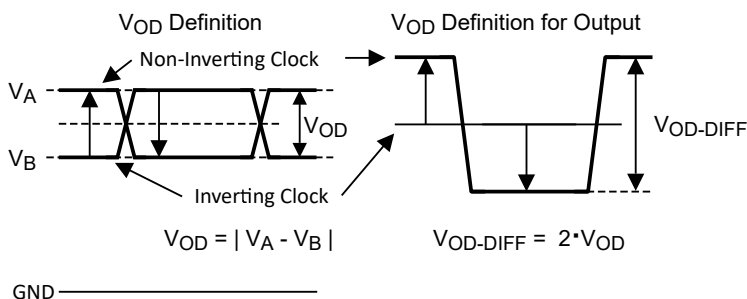


Figure 6-8. Two Different Definitions for Differential Output Signals

## 7 Detailed Description

### 7.1 Overview

The LMK3H0102 is a dual-channel clock generator primarily used for PCIe Gen 1 to Gen 7 clock generation, either with or without Spread Spectrum Clocking (SSC). The device has an integrated Bulk Acoustic Wave (BAW) resonator and does not require any external crystal or clock reference. The device has four selectable pages of memory, referred to as OTP pages. The collection of these pages in memory is referred to as the EFUSE.

The default output configuration is two 100MHz clocks, each with a 100Ω LP-HCSL output format, both disabled at start-up. The LMK3H0102 supports 100Ω LP-HCSL, 85Ω LP-HCSL, LVDS and 1.8V, 2.5V, or 3.3V LVCMOS output formats, as well as programmable output frequencies up to 200MHz for single-ended outputs and 400MHz for differential outputs. The LMK3H0102V33 is the part number for the default configuration with a 3.3V supply voltage. The LMK3H0102LMK3H0102V18 is the part number for the default configuration with a 1.8V supply voltage. Additional configuration part numbers are LMK3H0102Axxx, where xxx denotes the configuration number. [LMK3H0102 Configuration Guide](#) details the critical device settings and default register settings for each LMK3H0102Axxx OTP configuration.

The LMK3H0102 supports two functional modes determined by the REF\_CTRL pin at power-up: One-Time Programming (OTP) mode or I<sup>2</sup>C mode.

1. In OTP mode, one out of four OTP pages is selected by pins OTP\_SEL0 and OTP\_SEL1. The default output frequency across all OTP pages is 100MHz.
2. In I<sup>2</sup>C mode, the LMK3H0102 is configured by modifying the active registers. If a configuration other than the default operation is desired, the registers must be written every time at start-up.

Refer to [Pin Configuration and Functions](#) for the detailed descriptions of the device pins.

The LMK3H0102 has flexible SSC configurations, including:

1. SSC disabled on both outputs
2. SSC enabled on both outputs
3. SSC enabled on a single output

The SSC specifications and jitter performance are fully compliant to PCIe Gen 1 to Gen 7. Refer to [Spread-Spectrum Clocking](#) for SSC and jitter performance details.



## 7.2 Functional Block Diagram

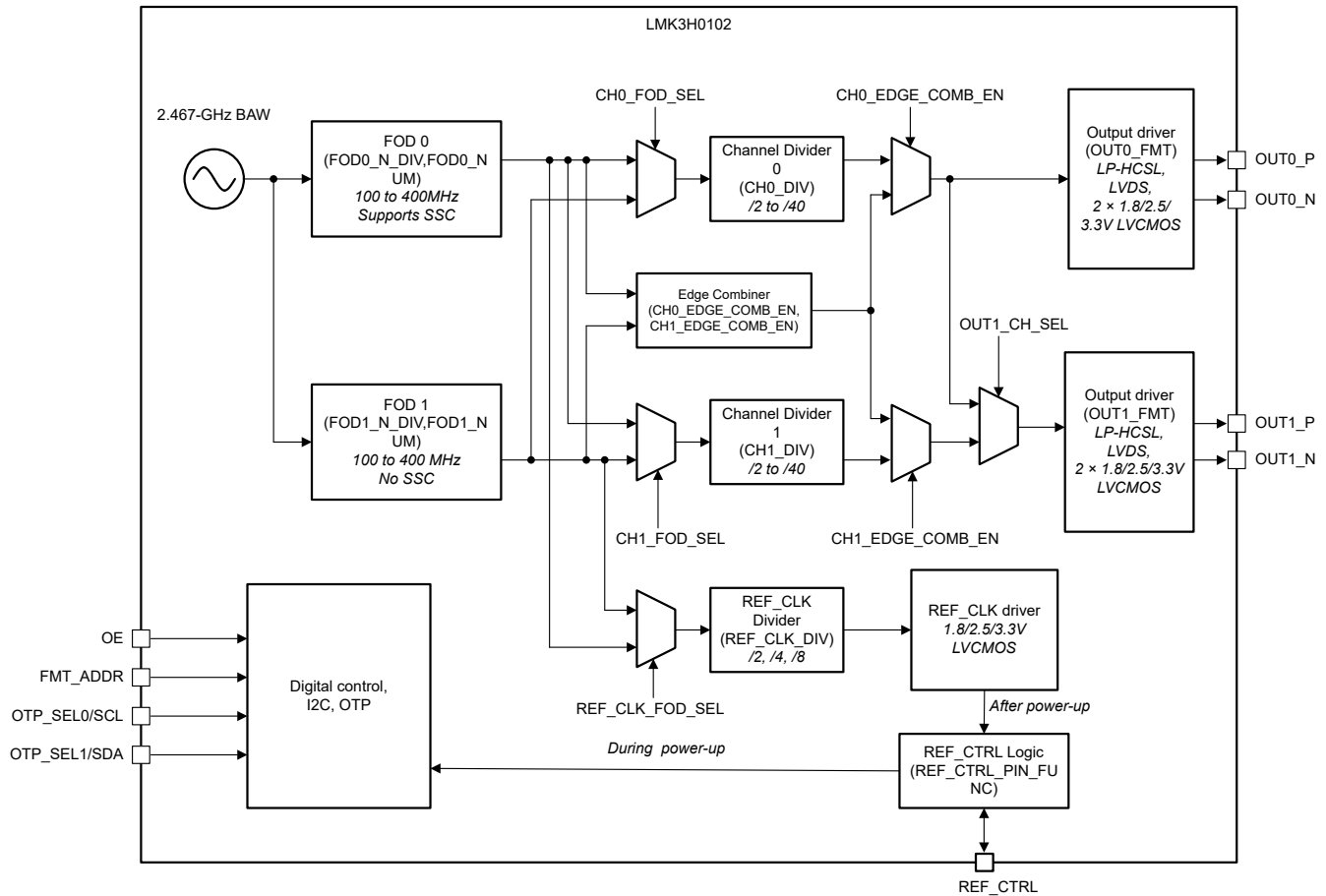


Figure 7-1. LMK3H0102 Functional Block Diagram

## 7.3 Feature Description

### 7.3.1 Device Block-Level Description

The LMK3H0102 is a reference-less clock generator with an integrated BAW oscillator. The BAW frequency, nominally 2467MHz, is divided down by two fractional output dividers (FODs), each of which is capable of generating frequencies between 100MHz and 400MHz. Each FOD can be routed to one of two channel dividers, which divides the FOD frequency down to generate frequencies from 2.5MHz to 200MHz. For generating frequencies above 200MHz, the edge combiner, which utilizes both FODs, must be used. In this case, the channel divider is bypassed, resulting in generated frequencies from 200MHz to 400MHz. An additional LVCMOS clock, with a voltage corresponding with VDD, can be optionally generated on the REF\_CTRL pin.

### 7.3.2 Device Configuration Control

Figure 7-2 shows the relationships between device states, the configuration pins, device initialization, and device operational modes. OTP mode is entered when the REF\_CTRL pin is pulled high at start-up. I<sup>2</sup>C mode is entered when the REF\_CTRL pin is pulled low at start-up. In OTP mode, the state of the OTP\_SEL0/SCL and OTP\_SEL1/SDA pins determines the OTP page that is loaded into the active registers. The device is one-time programmable, meaning that the register settings stored into the internal EFUSE can not be changed. The device can be transitioned from OTP to I<sup>2</sup>C mode, or reciprocally, by changing the state of the REF\_CTRL pin, then triggering a device power cycle by pulling VDD low, then high again. In OTP mode, a change in the level of the OTP\_SEL0 or OTP\_SEL1 pins, while keeping the REF\_CTRL pin high, dynamically changes the active OTP page. The device waits for 350µs for the OTP\_SEL0 and OTP\_SEL1 pins to settle before loading the new OTP page.

In I<sup>2</sup>C mode, the state of the FMT\_ADDR pin can determine the I<sup>2</sup>C address of the device, with the OTP\_SEL0/SCL and OTP\_SEL1/SDA pins re-purposed as I<sup>2</sup>C clock and data pins, respectively. In I<sup>2</sup>C mode, the host can update the active device registers. If using a configuration different than the programmed configuration, the registers must be written after each power cycle.

The device can be placed into a low power state by setting the PDN bit (R10[1]) to '1'. Clearing the PDN bit takes the device out of the low power state. If DEV\_IDLE\_STATE\_SEL bit (R10[4]) is a '0' and the outputs are disabled, the device enters the low power state. Entering the low power state is required for changing the frequency of the FOD used by Channel 0, changing the SSC configuration, and changing the output format. TI recommends performing register writes within this low power state. Set the OTP\_AUTOLOAD\_DIS (R10[2]) bit to a '1' to prevent automatic loading of OTP Page 0 prior to setting PDN to '0'.

There are two fields that determine the state of the device when coming out of the low power state. PIN\_RESAMPLE\_DIS (R10[3]) controls whether or not the FMT\_ADDR, OTP\_SEL0/SCL, OTP\_SEL1/SDA, and REF\_CTRL pins are resampled when exiting the low power state. If the pins are resampled, the device can be transitioned into OTP mode if the REF\_CTRL pin is pulled high. Set this bit to a '1' to disable this functionality. OTP\_AUTOLOAD\_DIS controls whether or not the contents of OTP Page 0 are loaded into the device registers when exiting the low power state. If OTP\_AUTOLOAD\_DIS bit is a '1' and PIN\_RESAMPLE\_DIS is a '1', then the register contents do not change. If OTP\_AUTOLOAD\_DIS bit is a '0' and PIN\_RESAMPLE\_DIS is a '1', then the contents of OTP Page 0 are loaded to the registers. If PIN\_RESAMPLE\_DIS is a '0' and REF\_CTRL is pulled high, then the device enters OTP Mode. In this case, OTP\_SEL0/SCL and OTP\_SEL1/SDA control the OTP page loaded into the device registers.

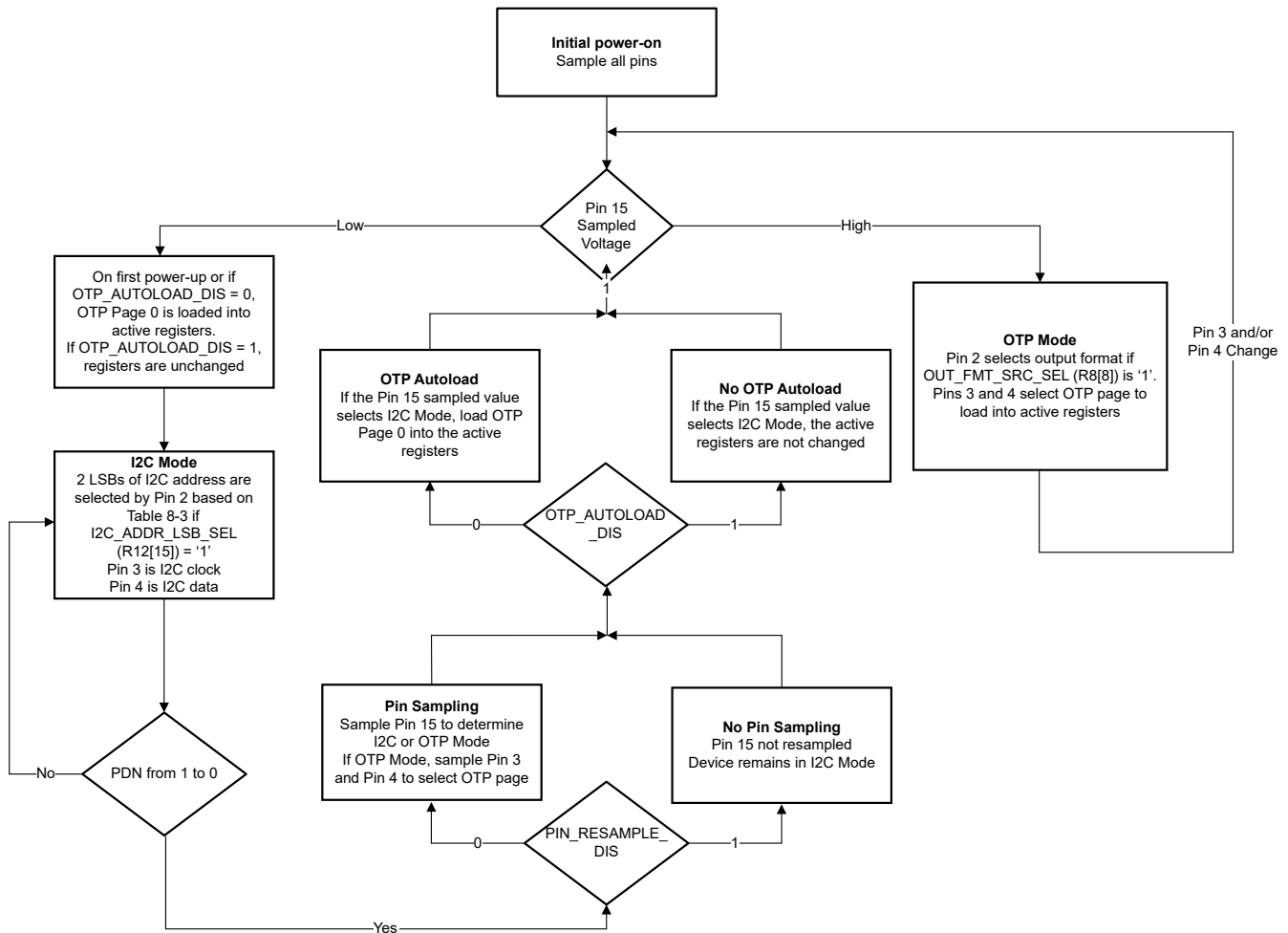


Figure 7-2. LMK3H0102 Device Mode Diagram

In I<sup>2</sup>C Mode, the device registers are from the contents of OTP Page 0. In OTP mode, these values come from one of the four OTP pages, selectable based on the state of the OTP\_SELx pins on start-up. Figure 7-3 shows interface and control blocks within the LMK3H0102, with the arrows referring to read and write access from the different embedded memories.

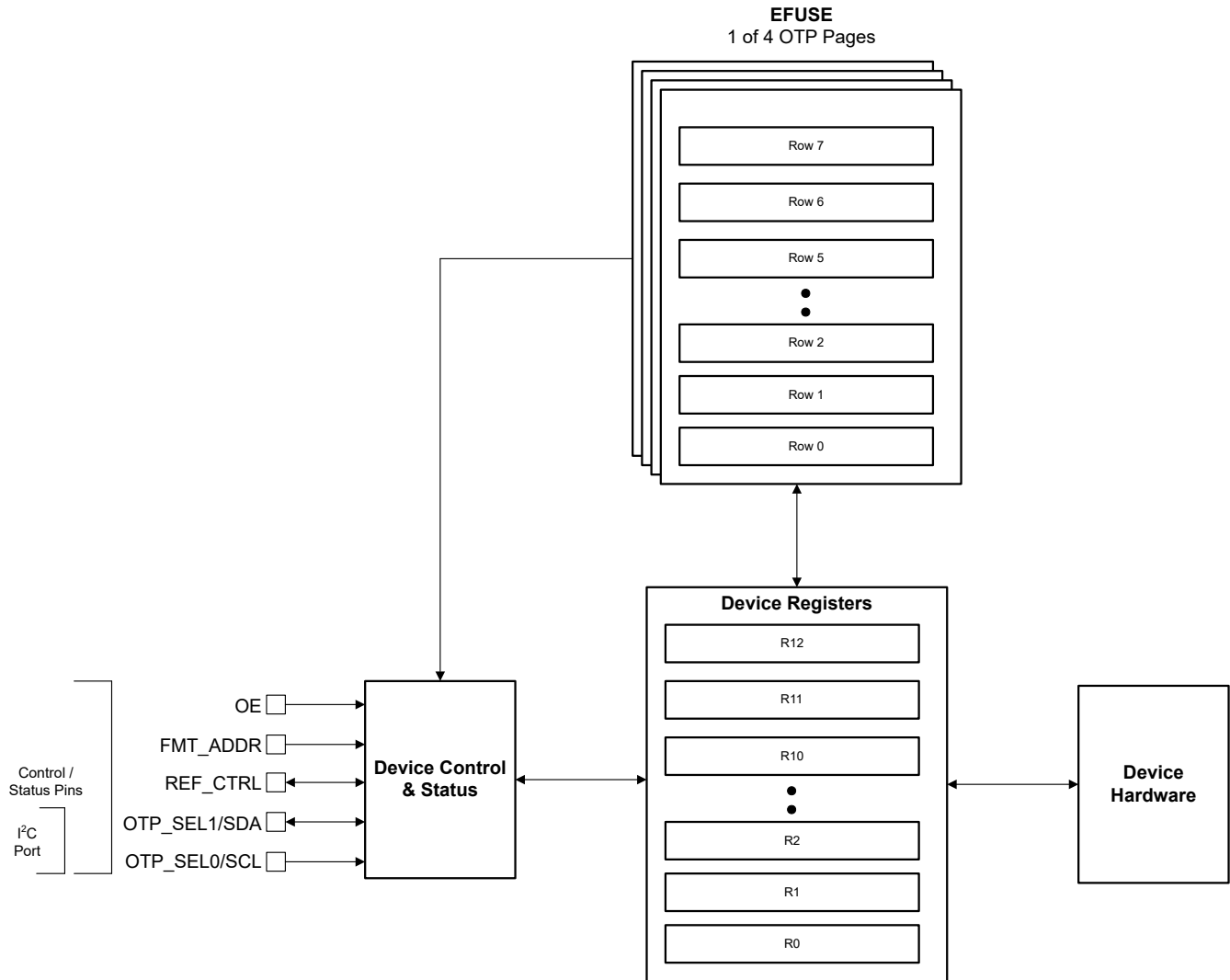


Figure 7-3. LMK3H0102 Interface and Control Blocks

### 7.3.3 OTP Mode

In this mode, the configuration pins allow for selection of one of four one-time programmable (OTP) pages, as well as output format selection. I<sup>2</sup>C is not enabled in this mode, as the I<sup>2</sup>C pins are repurposed for OTP page selection. Table 7-1 shows the OTP page selected based on the state of the OTP\_SEL0 and OTP\_SEL1 pins.

Table 7-1. OTP Page Selection in OTP Mode

OTP_SEL1 Pin	OTP_SEL0 Pin	OTP Page
Low	Low	0
Low	High	1
High	Low	2
High	High	3

The EFUSE of the devices is permanently programmed and has  $OTP\_BURNT(R0[0]) = 1$ . If a new configuration is desired, the configuration must be loaded through I<sup>2</sup>C on each start-up. OTP configurations can be created using the Wizard in TICS Pro. Contact TI for creation of a custom OTP configuration orderable part number.

The following fields can be unique between the four OTP pages. All other register settings are shared between the OTP pages:

- SSC\_EN: Enable or disable SSC.
- OE\_0: Enable or disable OUT0.
- OE\_1: Enable or disable OUT1.
- OP\_TYPE\_CH0: OUT0 output format type, see [Output Format Types](#).
- OP\_TYPE\_CH1: OUT1 output format type, see [Output Format Types](#).
- SSC\_SETTING: SSC modulation type, see [Spread Spectrum Clocking](#).

When OTP\_SEL1 or OTP\_SEL0 pin state changes, the device automatically goes through a power cycle and reloads the new OTP page. The time elapsed from when pins 3 and 4 change to a stable state in the new OTP is no more than 1.5ms.

### 7.3.4 I<sup>2</sup>C Mode

In this mode, I<sup>2</sup>C is enabled and the SCA and SDL pins function as the I<sup>2</sup>C clock and I<sup>2</sup>C data pins, respectively. [Table 7-2](#) shows the four default I<sup>2</sup>C addresses selectable by the FMT\_ADDR pin. The 5 MSBs of the I<sup>2</sup>C address are set in the upper five bits of I2C\_ADDR (R12[14:8]).

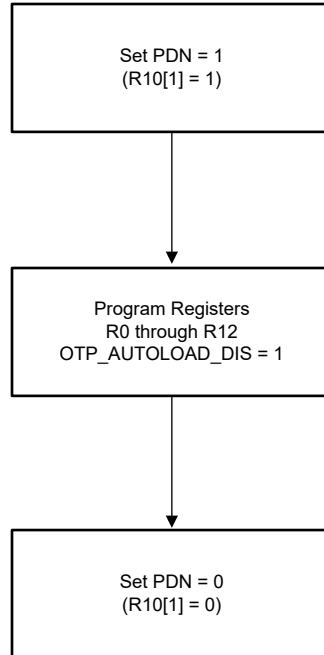
If I2C\_ADDR\_LSB\_SEL (R12[15]) = 0, then the FMT\_ADDR pin is ignored, and the I<sup>2</sup>C address is solely determined by I2C\_ADDR. If using the FMT\_ADDR pin for I<sup>2</sup>C LSB selection, then the pin must not be configured for individual output enable control.

**Table 7-2. I<sup>2</sup>C Address Selection**

REF_CTRL PIN <sup>(1)</sup>	FMT_ADDR PIN	I <sup>2</sup> C ADDRESS <sup>(2)</sup>
High	X	N/A (I2C disabled)
Low	0	0x68 / 0xD0
Low	1	0x69 / 0xD2
Low	Tied to SDA	0x6A / 0xD4
Low	Tied to SCL	0x6B / 0xD8

- (1) This is the state of the REF\_CTRL pin at power-up, not the live pin state.
- (2) The 0xD0, 0xD2, 0xD4, and 0xD8 addresses are with the R/W bit included set to '0'.

When changing the registers of the device, first set PDN to '1', write to the device registers, then set PDN to '0'. [Figure 7-4](#) shows this process.



**Figure 7-4. LMK3H0102 Programming Sequence**

## 7.4 Device Functional Modes

### 7.4.1 Fail-Safe Inputs

The LMK3H0102 digital input pins are designed to support fail-safe input operation, with the exception of the REF\_CTRL pin. This feature allows the user to drive the digital inputs before VDD is applied without damaging the device. Refer to [Absolute Maximum Ratings](#) for more information on the maximum input voltages supported by the device.

### 7.4.2 Fractional Output Dividers

The LMK3H0102 contains two fractional output dividers. If all outputs are able to be generated by a single FOD, TI recommends disabling FOD1 to conserve power and improve performance. If no output channels select FOD1, then FOD1 is disabled.

#### 7.4.2.1 FOD Operation

The internal BAW resonator is divided down by one or two Fractional Output Dividers (FODs). FOD0 has an SSC generator and FOD1 does not have an SSC generator. If both OUT0 and OUT1 must be SSC clocks, the two clocks must be sourced by FOD0. If one SSC clock and one non-SSC clock are required at the same time, then FOD0 is enabled for the SSC clock and FOD1 is enabled for the non-SSC clock. If neither output clock requires SSC, then either FOD can be used.

#### Note

TI recommends that FOD0 be used as the default FOD if only one FOD is needed for an application. If both FODs are in use, TI recommends using FOD0 with OUT0 and FOD1 with OUT1.

The maximum frequency that can be generated at the clock outputs by a single FOD is 200MHz, as the minimum channel divider value is a divide by two. To generate a greater than 200MHz output, the edge combiner is used, bypassing the channel dividers. This requires that both FODs are enabled and have the same integer divider and fractional numerator values, and the same gain calibration values. When one of the outputs exceeds 200MHz, the other output can only select the shared FOD frequency divided by one of the channel divider values, or be the FOD frequency. Below 200MHz, the two FODs can be configured independently so that OUT0

and OUT1 can have different frequencies. TI recommends sourcing from a single FOD whenever possible to make sure that OUT0 and OUT1 have a deterministic phase relationship.

The FODs in the LMK3H0102 can be configured to accommodate various output frequencies through I<sup>2</sup>C programming, or in the absence of programming, the one-time programmed (OTP) settings. The FODs can be configured by setting the integer (FODx\_N\_DIV) and fractional (FODx\_NUM) divide values. [Table 7-3](#) shows the register locations for these fields for each FOD.

**Table 7-3. FOD Integer and Numerator Divide Locations**

Field	Register
FOD0_N_DIV	R0[9:3]
FOD0_NUM[23:16]	R1[15:8]
FOD0_NUM[15:0]	R2[15:0]
FOD1_N_DIV	R3[15:9]
FOD1_NUM[23:16]	R6[12:5]
FOD1_NUM[15:0]	R8[15:0]

An example of how to set the integer and numerator divide values is shown in [Equation 1](#) and [Equation 2](#).

$$FODx\_N\_DIV = \text{floor}\left(\frac{F_{BAW}}{F_{FOD}}\right) \quad (1)$$

where:

- FODx\_N\_DIV: Integer portion of the FOD divide value (7 bits, 6 to 24)
- F<sub>BAW</sub>: BAW frequency, 2467MHz plus offset, described in further detail below
- F<sub>FOD</sub>: Desired FOD frequency (100MHz to 400MHz)

$$FODx\_NUM = \text{int}\left(\left(\left(\frac{F_{BAW}}{F_{FOD}}\right) - FODx\_N\_DIV\right) \times 2^{24}\right) \quad (2)$$

where FODx\_NUM is the fractional portion of the FOD divide value (24 bits, that is 0 to 16777215).

The output frequency (F<sub>OUT</sub>) is related to the FOD frequency as given in [Equation 3](#), or is equal to the FOD frequency when the edge combiner is enabled. OUTDIV can be 2, 4, 6, 8, 10, 20, or 40.

$$F_{OUT} = \frac{F_{FOD}}{OUTDIV} \quad (3)$$

Use [Equation 4](#) to calculate the actual value of the BAW frequency for a device. Users can find the value of BAWFREQ\_OFFSET\_FIXEDLUT by reading [R238](#), which is a signed 16-bit value.

$$F_{BAW} = 2467\text{MHz} \times (1 + (\text{BAWFREQ\_OFFSET\_FIXEDLUT} \times 128\text{E} - 9)) \quad (4)$$

#### 7.4.2.2 Edge Combiner

Use the edge combiner to generate output frequencies greater than 200MHz. To use the Edge Combiner, set CH0\_EDGE\_COMB\_EN ([R3\[3\]](#)) or CH1\_EDGE\_COMB\_EN ([R3\[7\]](#)) to '1'. When using the edge combiner, both FODs must operate at the same exact frequency (that is, the divide values must match). The device handles this by automatically loading the divider values from FOD0 into FOD1 when either CHx\_EDGE\_COMB\_EN bit is set to a '1'. SSC on FOD0 is not supported when using the edge combiner, and must not be enabled. Either of the FODs can still generate the LVCMOS REF\_CLK output.

For proper edge combiner operation, the following conditions must be true:

- The gain calibration codes for both FODs must be averaged. For example, if DTC1\_GAIN\_RT = 200, and DTC2\_GAIN\_RT = 220, then both of these fields must be written to 210. The gain calibration codes are in

the protected register space. Unlock the protected registers using R12[7:0] = 0x5B, write only the averaged gain calibration codes, and then lock the protected registers by setting R12[7:0] = 0x00. See [R146](#), [R147](#), and [R148](#) for more information.

- If the edge combiner is used for OUT1 **only**, CH0\_FOD\_SEL (R3[4]) must **always** be set to '0' (FOD0), regardless of the disable state of OUT0.

#### 7.4.2.3 Digital State Machine

The digital state machine of the LMK3H0102 has a clock that originates from one of the FODs. The FOD selected by CH0\_FOD\_SEL (R3[4]) drives the input to the state machine clock divider. The total divide value is the DIG\_CLK\_N\_DIV (R0[9:3]) field plus two. Set DIG\_CLK\_N\_DIV such that the FOD frequency divided by the total state machine clock divide value is between 40MHz and 50MHz. The divider value used to set this clock is equal to the value stored in . As an example, if the frequency of FOD0 is 200MHz, and CH0\_FOD\_SEL is a '0', then DIG\_CLK\_N\_DIV must be set to '2', as 200MHz divided by 4 is 50MHz.

#### 7.4.2.4 Spread-Spectrum Clocking

FOD0 supports spread-spectrum clocking (SSC). SSC can be used to reduce peak radiated emissions by modulating the output frequency. When SSC\_EN (R4[0]) = '1', any outputs that are sourced from FOD0 have SSC. SSC\_MOD\_TYPE (R4[1]) selects between down-spread modulation (SSC\_MOD\_TYPE = 0) or center-spread modulation (SSC\_MOD\_TYPE = 1). The LMK3H0102 has four built-in down-spread SSC options, as well as a custom SSC option. SSC\_CONFIG\_SEL (R9[11:9]) selects between the custom or preconfigured options. The preconfigured options are optimized for a 200MHz output from FOD0. [Table 7-4](#) details the register settings for the preconfigured SSC options. The preconfigured SSC options are optimized for 200MHz outputs from FOD0. If the edge combiner is used, then spread-spectrum clocking must be disabled.

**Table 7-4. Predefined SSC Configurations**

SSC_CONFIG_SEL	Down-spread SSC Depth
0x0	Custom, based on SSC_STEPS and SSC_STEP_SIZE
0x1	-0.10%
0x2	-0.25%
0x3	-0.30%
0x4	-0.50%
All other values	Reserved

If Custom SSC is selected, then SSC\_STEPS (R4[14:2]) and SSC\_STEP\_SIZE (R5) must be configured to set the modulation depth. Use [Equation 5](#) and [Equation 6](#) to determine the SSC\_STEPS (R4[14:2]) register settings, and use [Equation 7](#) or [Equation 8](#) to determine the SSC\_STEP\_SIZE (R5) settings. [Equation 7](#) is for down-spread SSC and [Equation 8](#) is for center-spread SSC.

$$\text{Down - spread: } \text{SSC\_STEPS} = \text{int}\left(\left(\frac{F_{\text{FOD0}}}{F_{\text{MOD}}}\right) \div 2\right) \quad (5)$$

$$\text{Center - spread: } \text{SSC\_STEPS} = \text{int}\left(\left(\frac{F_{\text{FOD0}}}{F_{\text{MOD}}}\right) \div 4\right) \quad (6)$$

where:

- F<sub>FOD0</sub>: FOD0 Frequency
- F<sub>MOD</sub>: Modulation frequency, use 31.5kHz for PCIe applications

$$\text{SSC\_STEP\_SIZE} = \text{floor}\left(\frac{\left(\left(\frac{F_{\text{BAW}}}{F_{\text{FOD0}}}\right) \times \left(\frac{1}{1 - \text{SSC\_DEPTH}}\right) - 1\right)}{\text{SSC\_STEPS} \times \text{DEN}}\right) \quad (7)$$

$$\text{SSC\_STEP\_SIZE} = \text{floor}\left(\frac{\left(\left(\frac{F_{\text{BAW}}}{F_{\text{FOD}}}\right) \times \left(\frac{1}{1 - \text{SSC\_DEPTH}}\right) - \left(\frac{1}{1 + \text{SSC\_DEPTH}}\right)\right)}{2 \times \text{SSC\_STEPS} \times \text{DEN}}\right) \quad (8)$$

where:

- **SSC\_STEP\_SIZE**: Numerator increment value per step for SSC
- **F<sub>BAW</sub>**: BAW frequency, 2467MHz. Note that the F<sub>BAW</sub> value varies from device to device.
- **SSC\_DEPTH**: Modulation depth, expressed as a positive value. If –0.5% depth is used, this value is 0.005
- **SSC\_STEPS**: Result from [Equation 5](#) for down-spread or [Equation 6](#) for center-spread
- **DEN**: Fractional denominator, 2<sup>24</sup>

If using a mix of SSC on one output and no SSC on a different output, there can be crosstalk between the two outputs. Contact TI to request measurement data for a specific configuration when configuring SSC on only a single output.

When modifying the SSC settings, do not set SSC\_EN to a '1' until the other SSC settings have been configured. Perform the following steps for configuring the SSC:

1. Set PDN to a '1'.
2. Set OTP\_AUTOLOAD\_DIS to a '1'.
3. Modify SSC\_MOD\_TYPE, SSC\_STEP\_SIZE, and SSC\_STEPS as necessary.
4. Set SSC\_EN to a '1'.
5. Set PDN to a '0'.

#### 7.4.2.5 Integer Boundary Spurs

When the decimal portion of the FOD divide value is near an integer boundary, integer boundary spurs can occur. In general, this "integer boundary" is when the decimal portion is between 0.9 and 1, or 0 and 0.1. For example, if the BAW frequency is 2467MHz, and an output of 122.88MHz, then the FOD must run at 245.76MHz. 2467MHz divided by 245.76MHz is approximately 10.038. The decimal portion of the divide value is 0.038, which falls between 0 and 0.1, and thus means that generating a 122.88MHz output can result in spurs in the 12kHz to 20MHz band on the output clock. In some cases, proper frequency planning can account for this by increasing the FOD frequency and the channel divider value. For any concerns about integer boundary spurs for a specific frequency plan, contact TI.

#### 7.4.3 Output Behavior

##### 7.4.3.1 Output Format Selection

This device supports LP-HCSL (both 85Ω and 100Ω internal termination), LVDS, and LVCMOS. For LVCMOS outputs, VDDO can be 1.8V, 2.5V or 3.3V if the VDD is 3.3V. Otherwise, the VDDO must be the same voltage as VDD. When OUT0 and OUT1 use different formats, DC-LVDS and differential LVCMOS are 180 degrees out of phase from all other formats.

**Table 7-5. Output Format Using Registers**

OUT0_FMT / OUT1_FMT	Description
0x0	LP-HCSL 100Ω Termination
0x1	LP-HCSL 85Ω Termination
0x2	AC-coupled LVDS
0x3	DC-coupled LVDS
0x4	LVCMOS enabled on OUTx_P LVCMOS disabled on OUTx_N
0x5	LVCMOS disabled on OUTx_P LVCMOS enabled on OUTx_N



**Table 7-5. Output Format Using Registers  
(continued)**

OUT0_FMT / OUT1_FMT	Description
0x6	LVC MOS enabled on OUT <sub>x</sub> _P LVC MOS enabled on OUT <sub>x</sub> _N 180 degrees out of phase (1)
0x7	LVC MOS enabled on OUT <sub>x</sub> _P LVC MOS enabled on OUT <sub>x</sub> _N OUT <sub>x</sub> _P and OUT <sub>x</sub> _N in phase

- (1) For best output performance, TI recommends using 180 degree out of phase LVC MOS if both OUT<sub>x</sub>\_P and OUT<sub>x</sub>\_N traces are required.

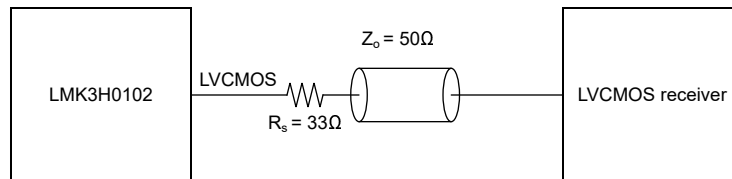
In OTP mode, the FMT\_ADDR pin function can be determined by OUT\_FMT\_SRC\_SEL (R9[8]). Table 7-6 describes the output format settings available using the OUT\_FMT\_SRC\_SEL field. If using the FMT\_ADDR pin for output format selection, the pin must not be configured for individual output enable.

**Table 7-6. FMT\_ADDR Output Format Options**

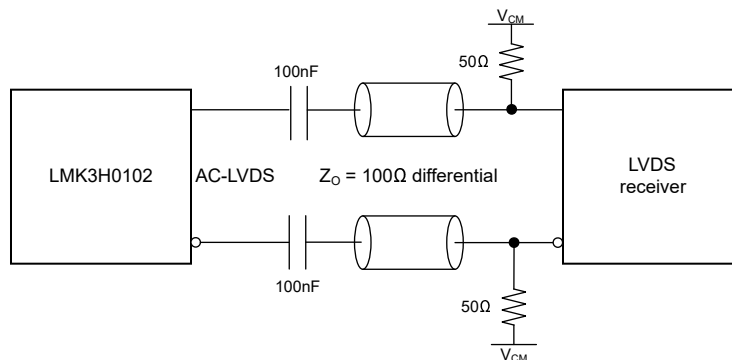
OUT_FMT_SR C_SEL	FMT_ADDR Pin	Output Format
0	X	Set by OUT0_FMT (R6[2:0]) / OUT1_FMT (R7[4:2])
1	GND	LP-HCSL 100Ω Termination
1	VDD	LP-HCSL 85Ω Termination

#### 7.4.3.1.1 Output Format Types

Figure 7-5 through Figure 7-8 display how to connect the LMK3H0102 outputs based on the output format selected.



**Figure 7-5. Interfacing LMK3H0102 LVC MOS Output With an LVC MOS Receiver**



**Figure 7-6. Interfacing LMK3H0102 LVC MOS Output With an AC-LVDS Receiver**

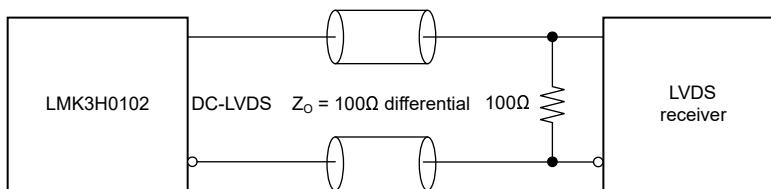


Figure 7-7. Interfacing LMK3H0102 LVCMOS Output With a DC-LVDS Receiver

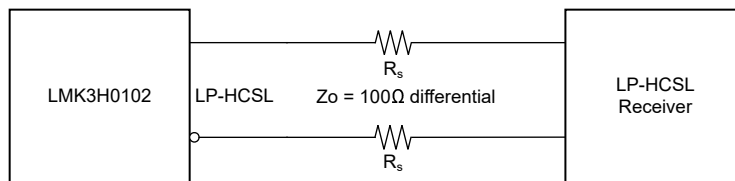


Figure 7-8. Interfacing LMK3H0102 LVCMOS Output With an LP-HCSL Receiver

#### 7.4.3.1.1 LP-HCSL Termination

For LP-HCSL outputs, the LMK3H0102 uses internal 50Ω termination resistors for the termination to GND. External termination resistors are not required.

#### 7.4.3.2 Output Slew Rate Control

For all LVDS and LP-HCSL outputs, the slew rate can be configured. OUT0\_SLEW\_RATE (R6[4:3]) and OUT1\_SLEW\_RATE (R7[6:5]) can be used to slow down output slew rate to reduce EMI for OUT0 and OUT1, respectively. Table 7-7 shows the slew rate options available.

Table 7-7. Slew Rate Settings

OUT0_SLEW_RATE OUT1_SLEW_RATE	Slew Rate
0x0	Between 2.3V/ns and 3.5V/ns
0x1	Between 2.0V/ns and 3.2V/ns
0x2	Between 1.7V/ns and 2.8V/ns
0x3	Between 1.4V/ns and 2.7V/ns

#### 7.4.3.3 REF\_CTRL Operation

At start-up, the REF\_CTRL pin selects I<sup>2</sup>C mode when low, and OTP mode when high. After start-up, REF\_CTRL can be programmed to output an LVCMOS REF\_CLK, which is derived from either FOD0 or FOD1 followed by an integer divider (/2, /4, /8). Alternatively, this pin can be disabled, or function as a "clock ready" signal. REF\_CTRL\_PIN\_FUNC (R7[14:13]) controls the function of the REF\_CTRL pin. Table 7-8 shows these options.

Table 7-8. REF\_CTRL Function After Start-Up

REF_CTRL_PIN_FUNC	REF_CTRL Function
0x0	Disabled, forced low
0x1	Disabled, tri-state
0x2	REF_CLK LVCMOS output
0x3	CLK_READY output

### 7.4.4 Output Enable

#### 7.4.4.1 Output Enable Control

This device supports synchronous Output Enable (OE). Synchronous OE means there is no glitch on the outputs when OE signal is asserted or deasserted.

The following table shows the enabling and disabling outputs through pin configuration and I<sup>2</sup>C. Note that the OE pin must be low **and** OE bit must be "1" for the output to be active. The output enable bits are OUT0\_EN (R7[1]) and OUT1\_EN (R7[8]).

**Table 7-9. OE Functionality**

OE Pin	OE Pin Polarity	Software Output Enable OUTx_EN	OUTx
High	Active low	0	Off
High	Active low	1	Off
Low	Active low	0	Off
Low	Active low	1	Running
High	Active high	0	Off
High	Active high	1	Running
Low	Active high	0	Off
Low	Active high	1	Off

#### 7.4.4.2 Output Enable Polarity

OE pin polarity is programmable. When the OE pin is active low, the internal pulldown resistor is automatically enabled, and the internal pullup resistor is disabled. When the OE pin is active high, the internal pullup resistor is automatically enabled, and the internal pulldown resistor is disabled. By default, clock outputs are enabled when the OE pin is floating. The OE pin polarity is set by OE\_PIN\_POLARITY (R7[0]) as '1' for active-low (default), or '0' for active-high.

#### 7.4.4.3 Individual Output Enable

The FMT\_ADDR pin can be reconfigured as a second output enable pin. Set SEPARATE\_OE\_EN (R11[14]) to enable this functionality. This bit is OTP programmable. When FMT\_ADDR is used as an output enable pin, the OE pin controls OUT0, and the FMT\_ADDR pin controls OUT1. The OE\_PIN\_POLARITY (R7[0]) bit applies to the OE and FMT\_ADDR pins in this case. If using the FMT\_ADDR pin for individual output enable control, the pin must not be configured for I<sup>2</sup>C LSB selection or output format selection.

#### 7.4.4.4 Output Disable Behavior

When the outputs are disabled, the outputs can be set to a tri-state condition or set to the levels in [Table 7-10](#), determined by OUT0\_DISABLE\_STATE (R3[5]) for OUT0 and OUT1\_DISABLE\_STATE (R3[6]) for OUT1.

**Table 7-10. Output Disable Behavior**

Output Format	OUTx_P	OUTx_N
LP-HCSL	LOW	LOW
AC-LVDS <sup>(1)</sup>	N/A	N/A
DC-LVDS <sup>(2)</sup>	HIGH	LOW
LVC MOS, P Only	LOW	LOW
LVC MOS, N Only	LOW	LOW
LVC MOS, Opposite Phase	HIGH	LOW
LVC MOS, In Phase	LOW	LOW

(1) DC-LVDS assumes that the outputs are DC terminated with 100Ω.

#### 7.4.5 Device Default Settings

[Table 7-11](#) summarizes the default settings of the LMK3H0102V33 and LMK3H0102V18 at start-up for the four OTP pages. In I<sup>2</sup>C mode, the Page 0 settings are loaded. For a full list of every default register setting, see [Device Registers](#).

**Table 7-11. LMK3H0102 Start-up Settings**

Parameter	OTP Page 0	OTP Page 1	OTP Page 2	OTP Page 3
VDD supply voltage	3.3V (LMK3H0102V33) 1.8V (LMK3H0102V18)			
OUT0 Frequency	100MHz	100MHz	100MHz	100MHz
OUT0 Output Format	100Ω LP-HCSL in I2C mode. Set by Pin 2 in OTP mode: • Pin 2 = Low: 100Ω LP-HCSL • Pin 2 = High: 85Ω LP-HCSL	Set by Pin 2: • Pin 2 = Low: 100Ω LP-HCSL • Pin 2 = High: 85Ω LP-HCSL	Set by Pin 2: • Pin 2 = Low: 100Ω LP-HCSL • Pin 2 = High: 85Ω LP-HCSL	Set by Pin 2: • Pin 2 = Low: 100Ω LP-HCSL • Pin 2 = High: 85Ω LP-HCSL
OUT0 Enable	Enable	Enable	Enable	Enable
OUT0 Differential Slew Rate	2.3V/ns to 3.5V/ns	2.3V/ns to 3.5V/ns	2.3V/ns to 3.5V/ns	2.3V/ns to 3.5V/ns
OUT0 LP-HCSL Amplitude	755mV (typical)	755mV (typical)	755mV (typical)	755mV (typical)
OUT0_P/N Disable Behavior	Low/Low	Low/Low	Low/Low	Low/Low
OUT1 Frequency	100MHz	100MHz	100MHz	100MHz
OUT1 Output Format	100Ω LP-HCSL in I2C mode. Set by Pin 2 in OTP mode: • Pin 2 = Low: 100Ω LP-HCSL • Pin 2 = High: 85Ω LP-HCSL	Set by Pin 2: • Pin 2 = Low: 100Ω LP-HCSL • Pin 2 = High: 85Ω LP-HCSL	Set by Pin 2: • Pin 2 = Low: 100Ω LP-HCSL • Pin 2 = High: 85Ω LP-HCSL	Set by Pin 2: • Pin 2 = Low: 100Ω LP-HCSL • Pin 2 = High: 85Ω LP-HCSL
OUT1 Enable	Enable	Enable	Enable	Enable
OUT1 Differential Slew Rate	2.3V/ns to 3.5V/ns	2.3V/ns to 3.5V/ns	2.3V/ns to 3.5V/ns	2.3V/ns to 3.5V/ns
OUT1 LP-HCSL Amplitude	755mV (typical)	755mV (typical)	755mV (typical)	755mV (typical)
OUT1_P/N Disable Behavior	Low/Low	Low/Low	Low/Low	Low/Low
REF_CTRL Behavior	CLK_READY	CLK_READY	CLK_READY	CLK_READY
FOD0 Frequency	200MHz	200MHz	200MHz	200MHz
FOD1 Frequency	200MHz	200MHz	200MHz	200MHz
SSC Enable	Disable	Enable	Enable	Enable
SSC Modulation Type	N/A	Down-spread	Down-spread	Down-spread
SSC Modulation Depth	N/A	-0.1%	-0.3%	-0.5%
Pin 2 Function	I2C Address LSB Selection (I <sup>2</sup> C Mode Only) Output Format Selection (OTP Mode Only)	I2C Address LSB Selection (I <sup>2</sup> C Mode Only) Output Format Selection (OTP Mode Only)	I2C Address LSB Selection (I <sup>2</sup> C Mode Only) Output Format Selection (OTP Mode Only)	I2C Address LSB Selection (I <sup>2</sup> C Mode Only) Output Format Selection (OTP Mode Only)

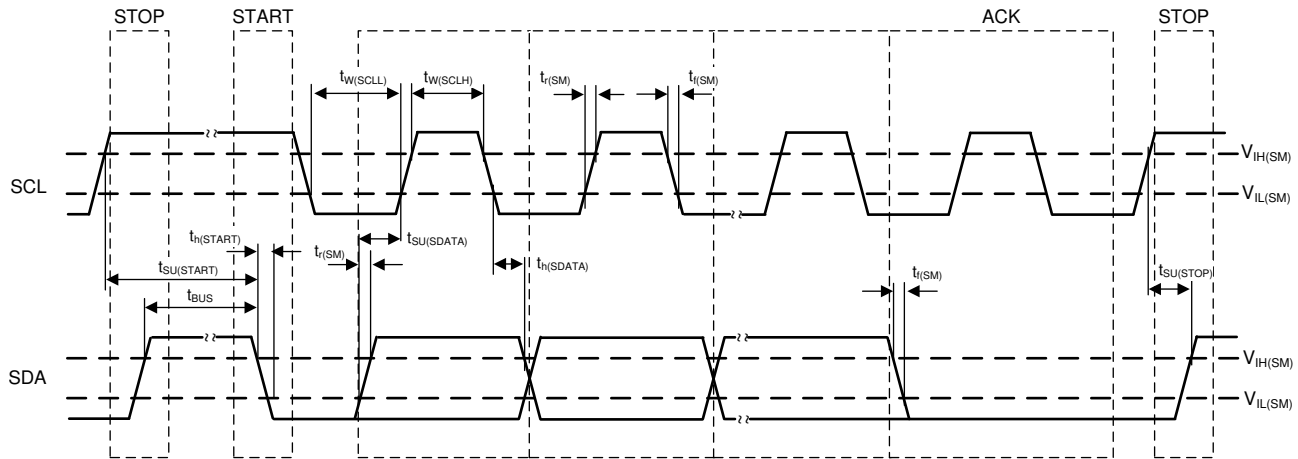
## 7.5 Programming

The host (DSP, Microcontroller, FPGA, and so forth) configures and monitors the LMK3H0102 through the I<sup>2</sup>C port. The host reads and writes to a collection of control bits called the register set. The device blocks can be controlled and monitored through a specific grouping of bits located within the register space. In the absence of the host, the LMK3H0102 can be configured to operate in OTP mode from one of four of the on-chip OTP pages, stored in the internal EFUSE, depending on the state of REF\_CTRL and OTP\_SELx pins. The EFUSE is one-time programmed by TI, and is not rewritable. This means that the values of the registers that are

automatically loaded from the EFUSE at power-up can not be customized. However, the values of the registers can be changed subsequently via the I<sup>2</sup>C register interface. Within the device registers, there are certain bits that have read/write access. Other bits are read-only (an attempt to write to a read only bit does not change the state of the bit). Certain device registers and bits are reserved meaning that the fields must not be changed from the default reset state.

### 7.5.1 I<sup>2</sup>C Serial Interface

The I<sup>2</sup>C port on the LMK3H0102 works as a peripheral device and supports both the 100kHz standard mode and 400kHz fast-mode operations. Fast mode imposes a glitch tolerance requirement on the control signals. Therefore, the input receivers ignore pulses of less than 50ns duration. The I<sup>2</sup>C timing requirements are provided in the *I<sup>2</sup>C Interface Specification*. Figure 7-9 shows the timing diagram.



**Figure 7-9. I<sup>2</sup>C Timing Diagram**

The LMK3H0102 is accessed through a 7-bit peripheral address transmitted as part of an I<sup>2</sup>C packet. Only the device with a matching peripheral address responds to subsequent I<sup>2</sup>C commands. In I<sup>2</sup>C mode, the LMK3H0102 allows up to four unique peripheral devices to occupy the I<sup>2</sup>C bus based on the pin strapping of FMT\_ADDR (tied to VDD, GND, SDA, or SCL). By default, the device peripheral address is 0b11010xx (the two LSBs are determined by the FMT\_ADDR pin). The full address can be configured through I<sup>2</sup>C.

During the data transfer through the I<sup>2</sup>C interface, one clock pulse is generated for each data bit transferred. The data on the SDA line must be stable during the high period of the clock. The high or low state of the data line can change only when the clock signal on the SCL line is low. The start data transfer condition is characterized by a high-to-low transition on the SDA line while SCL is high. The stop data transfer condition is characterized by a low-to-high transition on the SDA line while SCL is high. The start and stop conditions are always initiated by the controller. Every byte on the SDA line must be eight bits long. Each byte must be followed by an acknowledge bit and bytes are sent MSB first. The LMK3H0102 has an 8-bit register address, followed by a 16-bit data word.

The acknowledge bit (A) or non-acknowledge bit (A') is the 9th bit attached to any 8-bit data byte and is always generated by the receiver to inform the transmitter that the byte has been received (when A = 0) or not (when A' = 0). A = 0 is done by pulling the SDA line low during the 9th clock pulse and A' = 0 is done by leaving the SDA line high during the 9th clock pulse.

The I<sup>2</sup>C controller initiates the data transfer by asserting a start condition which initiates a response from all peripheral devices connected to the serial bus. Based on the 8-bit address byte sent by the controller over the SDA line (consisting of the 7-bit peripheral address (MSB first) and an R/W' bit), the device whose address corresponds to the transmitted address responds by sending an acknowledge bit. All other devices on the bus remain idle while the selected device waits for data transfer with the controller.

After the data transfer occurs, stop conditions are established. In write mode, the controller asserts a stop condition to end data transfer during the 10th clock pulse following the acknowledge bit for the last data byte from the peripheral. In read mode, the controller receives the last data byte from the peripheral but does not pull

SDA low during the 9th clock pulse. This is known as a non-acknowledge bit. By receiving the non-acknowledge bit, the peripheral knows the data transfer is finished and enters the idle mode. The controller then takes the data line low during the low period before the 10th clock pulse, and high during the 10th clock pulse to assert a stop condition. Figure 7-10 and Figure 7-11 show the sequence for block writes and block reads using the LMK3H0102, respectively.

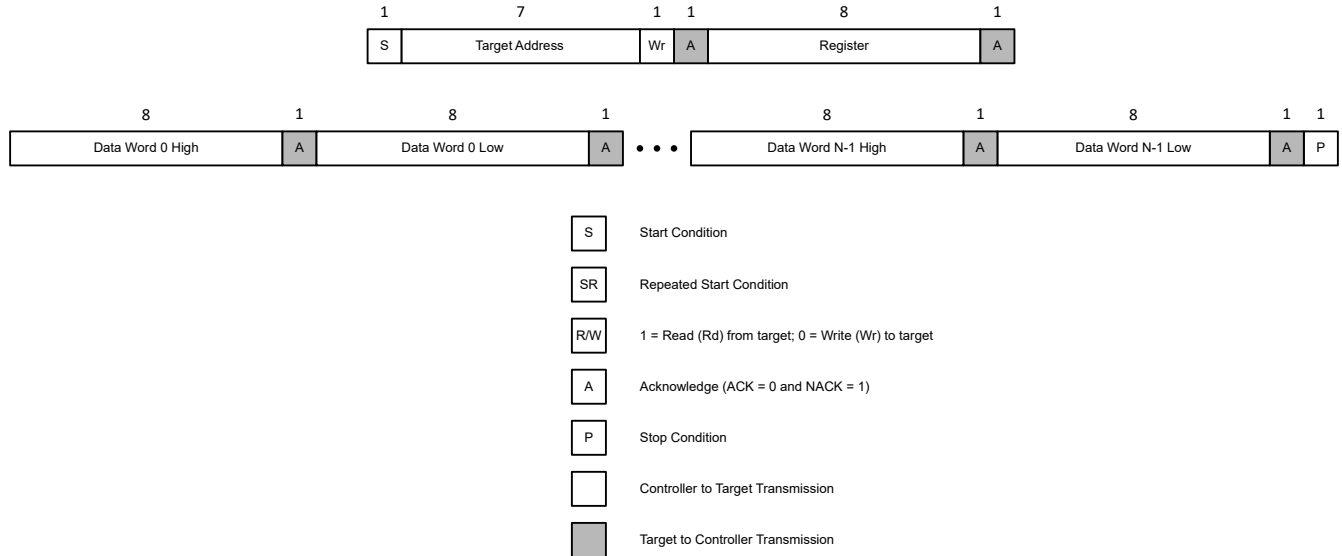


Figure 7-10. Generic Block Write Sequence

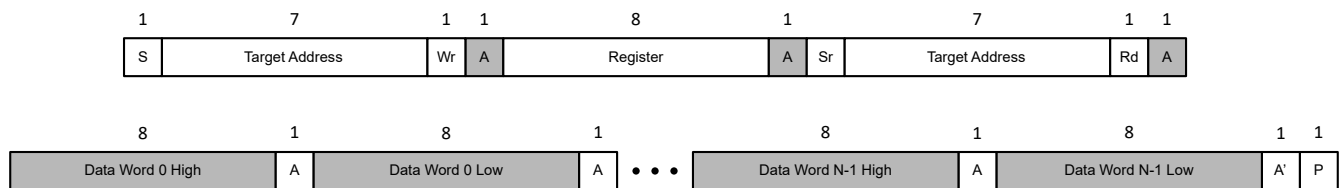


Figure 7-11. Generic Block Read Sequence

### 7.5.2 One-Time Programming Sequence

The upper register space includes all registers from R13 onward, as well as I2C\_ADDR (R12[15:8]). Unlocking the upper register space is performed by writing 0x5B to UNLOCK\_PROTECTED\_REG (R12[7:0]), leaving I2C\_ADDR unchanged. If using the edge combiner, performing the unlock first is required before modifying R146, R147, and R148.

There are six fields that can have different values depending on the EFUSE page loaded at device start-up.

- OUT0 Output Format
- OUT0 Enable
- OUT1 Output Format
- OUT1 Enable
- SSC Enable
- SSC Configuration (either preconfigured or custom)

All other fields retain the same value across all four EFUSE pages. For generating custom configurations, contact TI.

## 8 Device Registers

### 8.1 Register Maps

Table 8-1 lists the LMK3H0102 Device registers. All register offset address not listed in Table 8-1 can be considered as reserved locations and the register contents must not be modified.

**Table 8-1. LMK3H0102 Registers**

Address	Acronym	Section
0x0	R0	<a href="#">Go</a>
0x1	R1	<a href="#">Go</a>
0x2	R2	<a href="#">Go</a>
0x3	R3	<a href="#">Go</a>
0x4	R4	<a href="#">Go</a>
0x5	R5	<a href="#">Go</a>
0x6	R6	<a href="#">Go</a>
0x7	R7	<a href="#">Go</a>
0x8	R8	<a href="#">Go</a>
0x9	R9	<a href="#">Go</a>
0xA	R10	<a href="#">Go</a>
0xB	R11	<a href="#">Go</a>
0xC	R12	<a href="#">Go</a>
0x92	R146	<a href="#">Go</a>
0x93	R147	<a href="#">Go</a>
0x94	R148	<a href="#">Go</a>
0xEE	R238	<a href="#">Go</a>

Complex bit access types are encoded to fit into small table cells. Table 8-2 shows the codes that are used for access types in this section.

**Table 8-2. LMK3H0102 Access Type Codes**

Access Type	Code	Description
<b>Read Type</b>		
R	R	Read
<b>Write Type</b>		
W	W	Write
WL	W L	Write Locked, requires UNLOCK_PROTECT ED_REG (R12[7:0]) = 0x5B to unlock and write successfully

#### 8.1.1 R0 Register (Address = 0x0) [reset = 0x0861/0x0863]

R0 is shown in Table 8-3.

Return to the [Summary Table](#).

**Table 8-3. R0 Register Field Descriptions**

Bit	Field	Type	Reset	Description
15:10	DIG_CLK_N_DIV	R/W	0x02	Digital State Machine clock rate. Derived from the FOD frequency sourced by the CH0_FOD_SEL multiplexer. The target for the frequency is 50MHz maximum. The actual divide value is the DIG_CLK_N_DIV value plus 2. This field is stored in the EFUSE.
9:3	FOD0_N_DIV	R/W	0x0C	Integer Ratio of BAW frequency to FOD0 frequency. This field is stored in the EFUSE.
2:1	SUP_LVL_SEL	R/W	0x0 (V33) 0x1 (V18)	Operating voltage for core supply LDO. This field is factory programmed, and <b>must not</b> be overwritten with a different value than the programmed value. Supply voltage on VDD and VDDO pins <b>must not</b> exceed the selected voltage value + 10%. 0: 3.3V 1: 1.8V 2: 2.5V
0	OTP_BURNT	R/WL	0x1	Indicates that the EFUSE has been programmed. If this field is '1', the EFUSE is programmed.

**8.1.2 R1 Register (Address = 0x1) [reset = 0x5599]**

R1 is shown in [Table 8-4](#).

Return to the [Summary Table](#).

**Table 8-4. R1 Register Field Descriptions**

Bit	Field	Type	Reset	Description
15:8	FOD0_NUM[23:16]	R/W	0x55	High byte of the FOD0 fractional divide value. The value of this field changes from device to device. This field is stored in the EFUSE.
7:0	ADC_CLK_N_DIV	R/W	0x99	ADC clock frequency in MHz, derived directly from BAW. Default is $\text{ceil}(2467 / 16) - 2 = 0x99$ . This field is stored in the EFUSE. TI does not recommend modifying the value of this field.

**8.1.3 R2 Register (Address = 0x2) [reset = 0xC28F]**

R2 is shown in [Table 8-5](#).

Return to the [Summary Table](#).

**Table 8-5. R2 Register Field Descriptions**

Bit	Field	Type	Reset	Description
15:0	FOD0_NUM[15:0]	R/W	0xC28F	Lower two bytes of the FOD0 fractional divide value. The value of this field changes from device to device. This field is stored in the EFUSE.

**8.1.4 R3 Register (Address = 0x3) [reset = 0x1801]**

R3 is shown in [Table 8-6](#).

Return to the [Summary Table](#).

**Table 8-6. R3 Register Field Descriptions**

Bit	Field	Type	Reset	Description
15:9	FOD1_N_DIV	R/W	0x0C	Integer Ratio of BAW frequency to FOD1 frequency. This field is stored in the EFUSE.
8	CH1_FOD_SEL	R/W	0x0	Selects the FOD to use as the input source for Channel Divider 1. This field is stored in the EFUSE. 0h: FOD0. 1h: FOD1.



**Table 8-6. R3 Register Field Descriptions (continued)**

Bit	Field	Type	Reset	Description
7	CH1_EDGE_COMB_EN	R/W	0x0	Selects between using Channel Divider 1 or using the Edge Combiner as the input source for Output Driver 1. This field is stored in the EFUSE. 0h: Channel Divider 1 input 1h: Edge Combiner input
6	OUT1_DISABLE_STATE	R/W	0x0	When OUT1 is disabled, this bit selects whether the OUT1_P and OUT1_N pins are forced to GND or a tri-state condition. This field is stored in the EFUSE. 0h: Forced to GND on disable. 1h: Forced to a tri-state condition on disable.
5	OUT0_DISABLE_STATE	R/W	0x0	When OUT0 is disabled, this bit selects whether the OUT0_P and OUT0_N pins are forced to GND or a tri-state condition. This field is stored in the EFUSE. 0h: Forced to GND on disable. 1h: Forced to a tri-state condition on disable.
4	CH0_FOD_SEL	R/W	0x0	Selects the FOD to use as the input source for Channel Divider 0. This field is stored in the EFUSE. 0h: FOD0. 1h: FOD1.
3	CH0_EDGE_COMB_EN	R/W	0x0	Selects between using Channel Divider 0 or using the Edge Combiner as the input source for Output Driver 0. This field is stored in the EFUSE. 0h: Channel Divider 0 input 1h: Edge Combiner input
2:0	CH0_DIV	R/W	0x1	Divider value for Channel Divider 0. This field is stored in the EFUSE. 0h: Channel Divider disabled. Set CH0_DIV to '0' when using the edge combiner for OUT0. 1h: FOD / 2 2h: FOD / 4 3h: FOD / 6 4h: FOD / 8 5h: FOD / 10 6h: FOD / 20 7h: FOD / 40

**8.1.5 R4 Register (Address = 0x4) [reset = 0x0000]**

R4 is shown in [Table 8-7](#).

Return to the [Summary Table](#).

**Table 8-7. R4 Register Field Descriptions**

Bit	Field	Type	Reset	Description
15	Reserved	R	N/A	Reserved, do not write to this field.
14:2	SSC_STEPS	R/W	0x0000	Number of steps in each segment of the triangular profile for SSC. See <a href="#">Spread Spectrum Clocking</a> for instructions to calculate this value. This field is stored in the EFUSE.
1	SSC_MOD_TYPE	R/W	0x0	Selects between down-spread or center-spread modulation for custom SSC configurations. This field is stored in the EFUSE. 0h: Down-spread modulation. 1h: Center-spread modulation.

**Table 8-7. R4 Register Field Descriptions (continued)**

Bit	Field	Type	Reset	Description
0	SSC_EN	R/W	0x0	Enable SSC. This field is stored in the EFUSE. 0h: SSC Disabled. 1h: SSC Enabled.

**8.1.6 R5 Register (Address = 0x5) [reset = 0x0000]**

R5 is shown in [Table 8-8](#).

Return to the [Summary Table](#).

**Table 8-8. R5 Register Field Descriptions**

Bit	Field	Type	Reset	Description
15:0	SSC_STEP_SIZE	R/W	0x0000	Numerator increment value per step for SSC. See <a href="#">Spread Spectrum Clocking</a> for instructions to calculate this value. This field is stored in the EFUSE.

**8.1.7 R6 Register (Address = 0x6) [reset = 0x0AA0]**

R6 is shown in [Table 8-9](#).

Return to the [Summary Table](#).

**Table 8-9. R6 Register Field Descriptions**

Bit	Field	Type	Reset	Description
15:13	CH1_DIV	R/W	0x0	Divider value for Channel Divider 1. This field is stored in the EFUSE. 0h: Channel Divider disabled. Set CH1_DIV to '0' when using the edge combiner for OUT1. 1h: FOD / 2 2h: FOD / 4 3h: FOD / 6 4h: FOD / 8 5h: FOD / 10 6h: FOD / 20 7h: FOD / 40
12:5	FOD1_NUM[23:16]	R/W	0x55	High byte of the FOD1 fractional divide value. The value of this field changes from device to device. This field is stored in the EFUSE.
4:3	OUT0_SLEW_RATE	R/W	0x0	Slew rate control for OUT0. This field is stored in the EFUSE. Only applies to differential output formats. 0h: Between 2.3V/ns and 3.5V/ns. 1h: Between 2.0V/ns and 3.2V/ns. 2h: Between 1.7V/ns and 2.8V/ns. 3h: Between 1.4V/ns and 2.7V/ns.
2:0	OUT0_FMT	R/W	0x0	Selects the output format for OUT0. This field is stored in the EFUSE. 0h: LP-HCSL 100Ω Termination. 1h: LP-HCSL 85Ω Termination. 2h: AC-coupled LVDS. 3h: DC-coupled LVDS. 4h: LVCMOS, OUTx_P enabled, OUTx_N disabled. 5h: LVCMOS, OUTx_P disabled, OUTx_N enabled. 6h: LVCMOS, OUTx_P enabled, OUTx_N enabled, 180 degrees out of phase. 7h: LVCMOS, OUTx_P enabled, OUTx_N enabled, OUTx_P and OUTx_N in phase.

**8.1.8 R7 Register (Address = 0x7) [reset = 0x6503]**

R7 is shown in [Table 8-10](#).

Return to the [Summary Table](#).

**Table 8-10. R7 Register Field Descriptions**

Bit	Field	Type	Reset	Description
15	Reserved	N/A	0x0	Reserved, do not write to this field.
14:13	REF_CTRL_PIN_FUNC	R/W	0x3	Sets the function of the REF_CTRL pin. This field is stored in the EFUSE. 0h: REF_CTRL pin disabled, pulled to GND. 1h: REF_CTRL pin disabled, forced to a tri-state condition. 2h: REF_CTRL pin functions as an additional LVCMOS REF_CLK output. 3h: REF_CTRL pin functions as "clock ready" signal.
12:11	REF_CLK_DIV	R/W	0x0	REF_CLK output divisor value when REF_CTRL is used as REF_CLK. This field is stored in the EFUSE. 0h: REF_CLK disabled. 1h: FOD / 2. 2h: FOD / 4. 3h: FOD / 8.
10	Reserved	R/W	0x1	Reserved. Do not write any value other than '1' to this field.
9	REF_CLK_FOD_SEL	R/W	0x0	Select the FOD used to generate the REF_CLK output. This field is stored in the EFUSE. 0h: FOD0. 1h: FOD1.
8	OUT1_EN	R/W	0x1	Output Enable bit for OUT1. This field is stored in the EFUSE. 0h: OUT1 is disabled. 1h: OUT1 is enabled.
7	OUT1_CH_SEL	R/W	0x0	Selects the source for OUT1. If the Edge Combiner is enabled, then this bit is ignored. This field is stored in the EFUSE. 0h: OUT1 is sourced from Channel Divider 0 if CH0_EDGE_COMB_EN is a '0', or the Edge Combiner if CH0_EDGE_COMB_EN is a '1'. 1h: OUT1 is sourced from Channel Divider 1 if CH1_EDGE_COMB_EN is a '0', or the Edge Combiner if CH1_EDGE_COMB_EN is a '1'.
6:5	OUT1_SLEW_RATE	R/W	0x0	Slew rate control for OUT1. This field is stored in the EFUSE. Only applies to differential output formats. 0h: Between 2.3V/ns and 3.5V/ns. 1h: Between 2.0V/ns and 3.2V/ns. 2h: Between 1.7V/ns and 2.8V/ns. 3h: Between 1.4V/ns and 2.7V/ns.
4:2	OUT1_FMT	R/W	0x0	Selects the output format for OUT1. This field is stored in the EFUSE. 0h: LP-HCSL 100Ω Termination. 1h: LP-HCSL 85Ω Termination. 2h: AC-coupled LVDS. 3h: DC-coupled LVDS. 4h: LVCMOS, OUTx_P enabled, OUTx_N disabled. 5h: LVCMOS, OUTx_P disabled, OUTx_N enabled. 6h: LVCMOS, OUTx_P enabled, OUTx_N enabled, 180 degrees out of phase. 7h: LVCMOS, OUTx_P enabled, OUTx_N enabled, OUTx_P and OUTx_N in phase.
1	OUT0_EN	R/W	0x1	Output Enable bit for OUT0. This field is stored in the EFUSE. 0h: OUT0 is disabled. 1h: OUT0 is enabled.

**Table 8-10. R7 Register Field Descriptions (continued)**

Bit	Field	Type	Reset	Description
0	OE_PIN_POLARITY	R/W	0x1	OE pin polarity selection. This bit does not affect the polarity of the OUT <sub>x</sub> _EN bits, only the OE pin. This field is stored in the EFUSE. 0h: OE is active high (OE tied to VDD enables outputs). 1h: OE is active low (OE tied to GND enables outputs).

**8.1.9 R8 Register (Address = 0x8) [reset = 0xC28F]**

R8 is shown in [Table 8-11](#).

Return to the [Summary Table](#).

**Table 8-11. R8 Register Field Descriptions**

Bit	Field	Type	Reset	Description
15:0	FOD1_NUM[15:0]	R/W	0xC28F	Lower two bytes of the FOD1 fractional divide value. The value of this field changes from device to device. This field is stored in the EFUSE.

**8.1.10 R9 Register (Address = 0x9) [reset = 0x3166]**

R9 is shown in [Table 8-12](#).

Return to the [Summary Table](#).

**Table 8-12. R9 Register Field Descriptions**

Bit	Field	Type	Reset	Description
15:12	OTP_ID	R/W	0x3 (V33) 0x1 (V18)	Configurable field for identifying the OTP configuration. Can be used in I2C mode as a 4-bit spare field. This field is stored in the EFUSE.
11:9	SSC_CONFIG_SEL	R/W	0x0	SSC modulation configuration. If center-spread modulation is desired, then custom SSC configuration is required. Four preconfigured down-spread modulation depths are also available. Any other modulation depths require custom SSC configuration. This field is stored in the EFUSE. The preconfigured SSC options are specifically for 100MHz clock outputs. For other output frequencies, TI recommends creating a custom SSC configuration. 0h: Custom SSC Configuration - see <a href="#">Spread Spectrum Clocking</a> for details on creating a custom configuration. 1h: –0.10% preconfigured down-spread. 2h: –0.25% preconfigured down-spread. 3h: –0.30% preconfigured down-spread. 4h: –0.50% preconfigured down-spread. All other values: Reserved
8	OUT_FMT_SRC_SEL	R/W	0x1	Forces the FMT_ADDR pin to override the output format register settings in OTP Mode. When in I2C mode, the FMT_ADDR pin is never used for this purpose. This field is stored in the EFUSE. 0h: FMT_ADDR pin is ignored in OTP mode for output format selection. 1h: FMT_ADDR pin overrides the register settings in OTP mode. The output format is LP-HCSL, and the termination resistor values are based on the FMT_ADDR pin state on start-up.

**Table 8-12. R9 Register Field Descriptions (continued)**

Bit	Field	Type	Reset	Description
7:4	OUT1_LPHSCL_A MP_SEL	R/W	0x6	OUT1 output swing level when using LP-HCSL output format. This field is stored in the EFUSE. 0h: 625mV. 1h: 647mV. 2h: 668mV. 3h: 690mV. 4h: 712mV. 5h: 733mV. 6h: 755mV. 7h: 777mV. 8h: 798mV. 9h: 820mV. Ah: 842mV. Bh: 863mV. Ch: 885mV. Dh: 907mV. Eh: 928mV. Fh: 950mV.
3:0	OUT0_LPHSCL_A MP_SEL	R/W	0x6	OUT0 output swing level when using LP-HCSL output format. This field is stored in the EFUSE. 0h: 625mV. 1h: 647mV. 2h: 668mV. 3h: 690mV. 4h: 712mV. 5h: 733mV. 6h: 755mV. 7h: 777mV. 8h: 798mV. 9h: 820mV. Ah: 842mV. Bh: 863mV. Ch: 885mV. Dh: 907mV. Eh: 928mV. Fh: 950mV.

**8.1.11 R10 Register (Address = 0xA) [reset = 0x0010]**

R10 is shown in [Table 8-13](#).

Return to the [Summary Table](#).

**Table 8-13. R10 Register Field Descriptions**

Bit	Field	Type	Reset	Description
15	Reserved	R/W	0x0	Reserved. Only write '0' to this bit.
14:11	PROD_REVID	R	N/A	Product revision identifier.
10	CLK_READY	R	N/A	CLK_READY status. The REF_CTRL pin mirrors this status signal when the pin functions as a "clock ready" signal.
9	Reserved	R	N/A	Reserved, do not write to this field.
8	RB_PIN_15	R	N/A	Readback of the REF_CTRL pin.
7	RB_PIN_4	R	N/A	Readback of the OTP_SEL1/SDA pin.

**Table 8-13. R10 Register Field Descriptions (continued)**

Bit	Field	Type	Reset	Description
6	RB_PIN_3	R	N/A	Readback of the OTP_SEL0/SCL pin.
5	RB_PIN_2	R	N/A	Readback of the FMT_ADDR pin.
4	DEV_IDLE_STATE_SEL	R/W	0x1	This bit controls the behavior of the device when both outputs are disabled. Placing the device into a low-power state is not recommended for PCIe applications, as the time to re-enable the clocks is extended. This field is stored in the EFUSE. 0h: When both outputs are disabled, the outputs are muted, and the device is placed into a low-power state. 1h: When both outputs are disabled, the outputs are muted. The device does not enter a low-power state.
3	PIN_RESAMPLE_DIS	R/W	0x0	This bit controls the resampling of the device pins when exiting the low power mode. Write this bit while in the low power mode. TI recommends keeping this bit as a '1' unless the functionality is explicitly desired. 0h: Pin resampling is enabled. When exiting the low power mode, the FMT_ADDR, OTP_SEL0/SCL, OTP_SEL1/SDA, and FMT_ADDR pins are resampled. If FMT_ADDR is high, the device enters OTP Mode. 1h: Pin resampling is disabled. When exiting the low power mode, the FMT_ADDR, OTP_SEL0/SCL, OTP_SEL1/SDA, and FMT_ADDR pins are not resampled. The device remains in I2C Mode.
2	OTP_AUTOLOAD_DIS	R/W	0x0	This bit controls the behavior of the device when exiting the low power mode. Write this bit while in the low power mode. TI recommends keeping this bit as a '1' unless the functionality is explicitly desired. 0h: OTP autoload is enabled. When exiting the low power mode, the contents of OTP Page 0 are written to the device registers. 1h: OTP autoload is disabled. When exiting the low power mode, the contents of OTP Page 0 are not written to the device registers.
1	PDN	R/W	0x0	Writing a '1' to this bit puts the device into a low power state.
0	Reserved	R/W	0x0	Reserved. Only write '0' to this bit.

**8.1.12 R11 Register (Address = 0xB) [reset = 0x0000]**R11 is shown in [Table 8-14](#).Return to the [Summary Table](#).**Table 8-14. R11 Register Field Descriptions**

Bit	Field	Type	Reset	Description
15	Reserved	R/W	0x0	Reserved. Only write '0' to this bit.
14	SEPARATE_OE_EN	R/W	0x0	This bit enables the separate output enable functionality of the device. If this bit is a '1', then OUT_FMT_SRC_SEL and I2C_ADDR_LSB_SEL must be set to '0'. This field is stored in the EFUSE. 0h: Pin 1 is the output enable for OUT0 and OUT1. 1h: Pin 1 is the output enable for OUT0, Pin 2 is the output enable for OUT1.
13:0	Reserved	R/W	0x0000	Reserved, do not write to this field.

**8.1.13 R12 Register (Address = 0xC) [reset = 0xE800]**R12 is shown in [Table 8-15](#).Return to the [Summary Table](#).

**Table 8-15. R12 Register Field Descriptions**

Bit	Field	Type	Reset	Description
15	I2C_ADDR_LSB_SEL	R/WL	0x1	I2C peripheral address source. If this bit is a '1', SEPARATE_OE_EN must be '0'. This field is stored in the EFUSE. 0h: I2C peripheral address comes entirely from the I2C_ADDR field. 1h: The two lowest bits of the I2C peripheral address come from the FMT_ADDR pin, all other bits come from R12[14:10].
14:8	I2C_ADDR	R/WL	0x68	I2C peripheral address. After writing to this field, the device responds to the new I2C address. This field is stored in the EFUSE.
7:0	UNLOCK_PROTECTED_REG	R/W	0x00	This field locks all registers from R13 onward, in addition to R12[15:8]. Registers R13 onward are largely device calibration registers, and the contents modified if not described in this document. These registers can be read from normally regardless of the unlock status. 5Bh: Unlocks register writes for R12[15:8] and above. Any other value: R12[15:8] and above ignore all writes.

**8.1.14 R146 Register (Address = 0x92) [reset = 0x0000]**

R146 is shown in [Table 8-16](#).

Return to the [Summary Table](#).

**Table 8-16. R146 Register Field Descriptions**

Bit	Field	Type	Reset	Description
15:13	Reserved	R/WL	0x0	Reserved, do not write to this field.
12:5	DTC1_GAIN_RT	R/WL	0x00	Room temperature gain calibration code for FOD0. The value of this field varies from device to device. This must be averaged with DTC2_GAIN_RT when using the edge combiner. This field is stored in the EFUSE.
4:0	DTC1_GAIN_DELTA_CT	R/WL	0x00	Cold temperature gain calibration code for FOD0. The value of this field varies from device to device. This must be averaged with DTC2_GAIN_DELTA_CT when using the edge combiner. This field is stored in the EFUSE.

**8.1.15 R147 Register (Address = 0x93) [reset = 0x0000]**

R147 is shown in [Table 8-17](#).

Return to the [Summary Table](#).

**Table 8-17. R147 Register Field Descriptions**

Bit	Field	Type	Reset	Description
15:11	Reserved	R/WL	0x00	Reserved, do not write to this field.
13:8	DTC2_GAIN_DELTA_CT	R/WL	0x00	Cold temperature gain calibration code for FOD1. The value of this field varies from device to device. This must be averaged with DTC1_GAIN_DELTA_CT when using the edge combiner. This field is stored in the EFUSE.
7:0	DTC1_GAIN_DELTA_HT	R/WL	0x00	Hot temperature gain calibration code for FOD0. The value of this field varies from device to device. This must be averaged with DTC2_GAIN_DELTA_HT when using the edge combiner. This field is stored in the EFUSE.

**8.1.16 R148 Register (Address = 0x94) [reset = 0x0000]**

R148 is shown in [Table 8-18](#).

Return to the [Summary Table](#).

**Table 8-18. R148 Register Field Descriptions**

Bit	Field	Type	Reset	Description
15:14	Reserved	R/WL	0x0	Reserved, do not write to this field.

**Table 8-18. R148 Register Field Descriptions (continued)**

Bit	Field	Type	Reset	Description
13:8	DTC2_GAIN_DELTA_HT	R/WL	0x00	Hot temperature gain calibration code for FOD1. The value of this field varies from device to device. This must be averaged with DTC1_GAIN_DELTA_HT when using the edge combiner. This field is stored in the EFUSE.
7:0	DTC2_GAIN_RT	R/WL	0x00	Room temperature gain calibration code for FOD1. The value of this field varies from device to device. This must be averaged with DTC1_GAIN_RT when using the edge combiner. This field is stored in the EFUSE.

**8.1.17 R238 Register (Address = 0xEE) [reset = 0x0000]**

R246 is shown in [Table 8-19](#).

Return to the [Summary Table](#).

**Table 8-19. R246 Register Field Descriptions**

Bit	Field	Type	Reset	Description
15:0	BAWFREQ_OFFSET_FIXEDLUT	R/WL	0x0000	Offset value from 2467MHz for the BAW frequency. Signed 16-bit integer value. This field is stored in the EFUSE. Each bit of this fields corresponds to 128ppm of frequency deviation. <b>This field varies from part to part.</b> This field is for calculation purposes only, the device does not use this register for any internal calculation. Do <b>NOT</b> write to this field.



## 9 Application and Implementation

### Note

Information in the following applications sections is not part of the TI component specification, and TI does not warrant its accuracy or completeness. TI's customers are responsible for determining suitability of components for their purposes, as well as validating and testing their design implementation to confirm system functionality.

### 9.1 Application Information

The LMK3H0102 is a reference-less BAW-based clock generator that can be used to provide reference clocks for various applications, including PCIe reference clocking and XTAL/XO replacement.

### 9.2 Typical Applications

#### 9.2.1 Application Block Diagram Examples

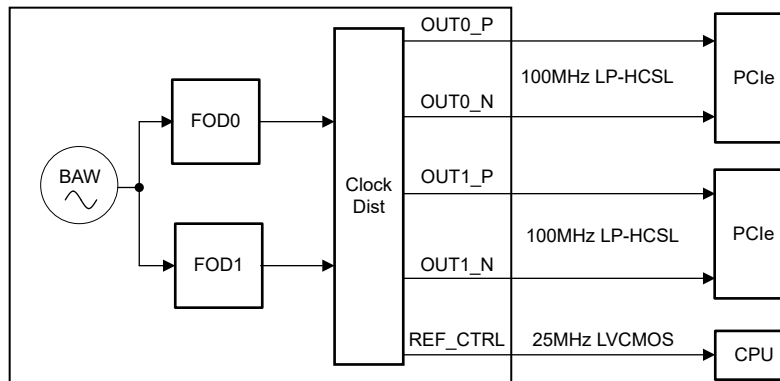


Figure 9-1. PCIe Applications

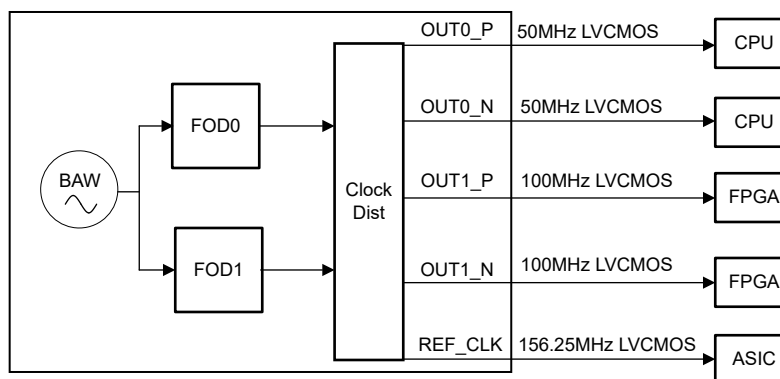


Figure 9-2. Five XO Replacement

#### 9.2.2 Design Requirements

Consider a typical PCIe application. In a system such as this, the clocks are expected to be available upon request without the need for any additional device-level programming. A typical output clock requirement in this application is two 100MHz LP-HCSL clocks. A 25MHz clock is added to show how to configure the REF\_CLK output as well. The section below describes the detailed design procedure to generate the required output frequencies for the above PCIe scenario using the LMK3H0102.

### 9.2.3 Detailed Design Procedure

Design of all aspects of the LMK3H0102 is straightforward, and software support is available to assist in frequency planning and part programming. This design procedure gives a straightforward outline of the process.

#### 1. Frequency Planning

- a. The first step of designing an LMK3H0102 configuration is to determine the FOD frequencies that are required to generate the required output frequencies. The process is as such:
  - i. If the output frequencies are greater than 200MHz, the frequencies must both be the same, and can not use SSC. If the frequencies are different, or require SSC, then this frequency plan can not be supported by the device.
    - In the case of two identical frequencies greater than 200MHz, the edge combiner must be enabled, the FOD divider values must match, and REF\_CLK, if used, can be sourced from either FOD.
  - ii. If both output frequencies are the same, and have the same SSC settings (that is, both use SSC or both do not use SSC), only one FOD is required.
  - iii. If both output frequencies are different, but have the same SSC settings, the outputs can share an FOD to conserve current. If both frequencies can be generated from dividing a single valid FOD frequency by the channel divider options, then the second FOD can be disabled. Otherwise, both FODs must be used. If both outputs require SSC, then this frequency plan can not be supported by the LMK3H0102 device.
  - iv. If one output requires SSC and the other does not, then the SSC output must use FOD0 and the non-SSC output must use FOD1.
- b. If SSC is being used, determine whether or not a preconfigured down-spread modulation, a custom down-spread modulation, or a center-spread modulation is required for the application. If a custom configuration is required, follow the steps outlined in [Spread-Spectrum Clocking](#).
- c. Set the digital clock divider such that the digital clock frequency is as close to 50MHz as possible.
- d. Determine the REF\_CTRL pin functionality. If this is used as an additional LVCMOS reference clock, verify that the desired frequency can be generated based on the FOD0 and FOD1 frequencies, as the divider range for the REF\_CLK output is /2, /4, or /8 only.
  - i. Keep in mind that if SSC is used on FOD0, and the REF\_CLK source is FOD0, this output now has SSC as well.

#### 2. Setting the Output Formats

- a. The output formats that are required are based upon the clock format needed in the system. For PCIe applications, this is most often a 100MHz LP-HCSL clock. The internal termination resistance value must be chosen such that the impedance matches the input impedance of the receiver. Note that the termination scheme is different for AC-LVDS and DC-LVDS - an AC-LVDS receiver requires an AC-LVDS output from the LMK3H0102.
- b. For differential outputs, the slew rate is selectable, from the slowest range (1.4V/ns to 2.7V/ns) to the fastest range (2.3V/ns to 3.5V/ns).
- c. For LP-HCSL outputs of either termination scheme, the amplitude is selectable between 625mV and 950mV.
- d. For LVCMOS outputs, the P and N phases can be in phase, opposite, or individually enabled or disabled. This allows for the generation of up to five LVCMOS clocks between OUT0, OUT1, and the REF\_CTRL pin.
  - i. For LVCMOS outputs, the VDDO\_x voltage MUST match the VDD voltage if VDD is 1.8V or 2.5V.

#### 3. Output Enable Behavior

- a. The output enable pin is active low by default, with an internal pulldown resistor to GND. If this functionality is not desired, then OE\_PIN\_POLARITY can be set to '0' to change the behavior of the OE pin to active-high. If this is done, the internal pulldown is disabled, and an internal pullup to VDD is used.

- b. Determine whether or not both outputs being disabled means that the device enters low-power mode. While this is able to conserve current, low-power mode is not recommended for any applications where the clocks must turn back on quickly, such as PCIe clocking.

For the PCIe example, the following settings are required:

1. One FOD can be used to generate both LP-HCSL outputs. As such, FOD0 can be set to have an output frequency of 200MHz, with Channel Divider 0 set to divide by two. Alternatively, FOD0 can be set to 400MHz with a divider by four. Both configurations are valid. Both output drivers select Channel Divider 0, and are both set to LP-HCSL.
  - a. DIG\_CLK\_N\_DIV must be set to two to set the state machine clock properly. The state machine clock must be as close to 50MHz as possible without exceeding this frequency. Equation 9 shows the relationship between the digital state machine frequency, the frequency selected by the CH0\_FOD\_SEL multiplexer, and the DIG\_CLK\_N\_DIV field. Write the DIG\_CLK\_N\_DIV field only while the device is in the low power state.
2. FOD0 can be used to generate the 25MHz LVCMOS clock, 200MHz / 8 = 25MHz. The REF\_CLK divider options are divides by two, four, or eight. Therefore, REF\_CLK\_DIV must be set to 3 for achieving a divide by 8.

$$F_{DIG} = \frac{F_{CH0\_FOD\_SEL}}{2 + DIG\_CLK\_N\_DIV} \quad (9)$$

where  $F_{DIG}$  is the digital state machine clock frequency and  $F_{CH0\_FOD\_SEL}$  is the frequency selected by the CH0\_FOD\_SEL multiplexer

#### 9.2.4 Example: Changing Output Frequency

If the user wants to change the output from 100MHz LP-HCSL on OUT0 and OUT1 to 24MHz differential LVCMOS clocks on OUT0 and OUT1– with an additional LVCMOS clock on the REF\_CTRL pin, the value of the BAWFREQ\_OFFSET\_FIXEDLUT field for this example is 0x3701. The steps for changing the frequency are as follows:

1. Determine the BAW frequency of the device. This is critical for all following calculations. From Equation 4, if BAWFREQ\_OFFSET\_FIXEDLUT is 0x3701, then the BAW frequency of this device is approximately 2471.446441856.
2. Determine the channel divider settings and required FOD frequency. If the output frequency is 24MHz, and the range of the FODs is from 100MHz to 400MHz, then a channel divider value of at least 5 is required to generate the output. As there is not a divide by 5 option, and REF\_CLK must also have a clock (see CH0\_DIV, CH1\_DIV, and REF\_CLK\_DIV), a divide by 8 is required. From here, 24MHz times 8 yields an FOD output frequency of 192MHz. If OUT1 is a different frequency, then using FOD1 can be required if both frequencies cannot be generated by dividing down from the same FOD frequency.
3. Set the FOD divide values. Use Equation 1 to calculate the integer divide value  $FOD0\_N\_DIV = \text{floor}(2471.446441856/192) = 12$ . From Equation 2, the numerator divide value  $FOD0\_NUM = \text{int}(((2471.446441856/192) - 12) \times 2^{24}) = 14631693$
4. Write the desired settings to the device registers. This includes the divider settings listed above, as well as the output driver settings. Follow the procedure outlined in Figure 7-4:
  - a. Set PDN = 1.
  - b. Set FOD0\_N\_DIV = 12 and FOD0\_NUM = 14631693.
  - c. Set CH0\_DIV, and REF\_CLK\_DIV to divide by 8 (by default, OUT1\_CH\_SEL is set to select Channel Divider 0).
  - d. Set OUT0\_FMT and OUT1\_FMT to select Differential LVCMOS as the output format.
  - e. Set REF\_CTRL\_PIN\_FUNC to output REF\_CLK.
  - f. Set OTP\_AUTOLOAD\_DIS to 1 (disable the OTP Page 0 autoloader feature).
  - g. Set DIG\_CLK\_N\_DIV = 2 to set the digital state machine clock to 48MHz, based on Equation 9

h. Set PDN = 0

The time required for the frequency change to take affect is typically on the order of 1ms between issuing PDN = 0 and the output clocks starting at the desired frequency.

### 9.2.5 Crosstalk

Performance degradation can occur in the LMK3H0102 due to crosstalk in the device when the outputs are operating at different frequencies. [Table 9-1](#) displays the performance of the LMK3H0102 outputs for common LVCMOS frequencies. Contact TI for measurement of additional combinations for impact of crosstalk on output performance.

**Table 9-1. LMK3H0102 LVCMOS Output Crosstalk <sup>(1)</sup>**

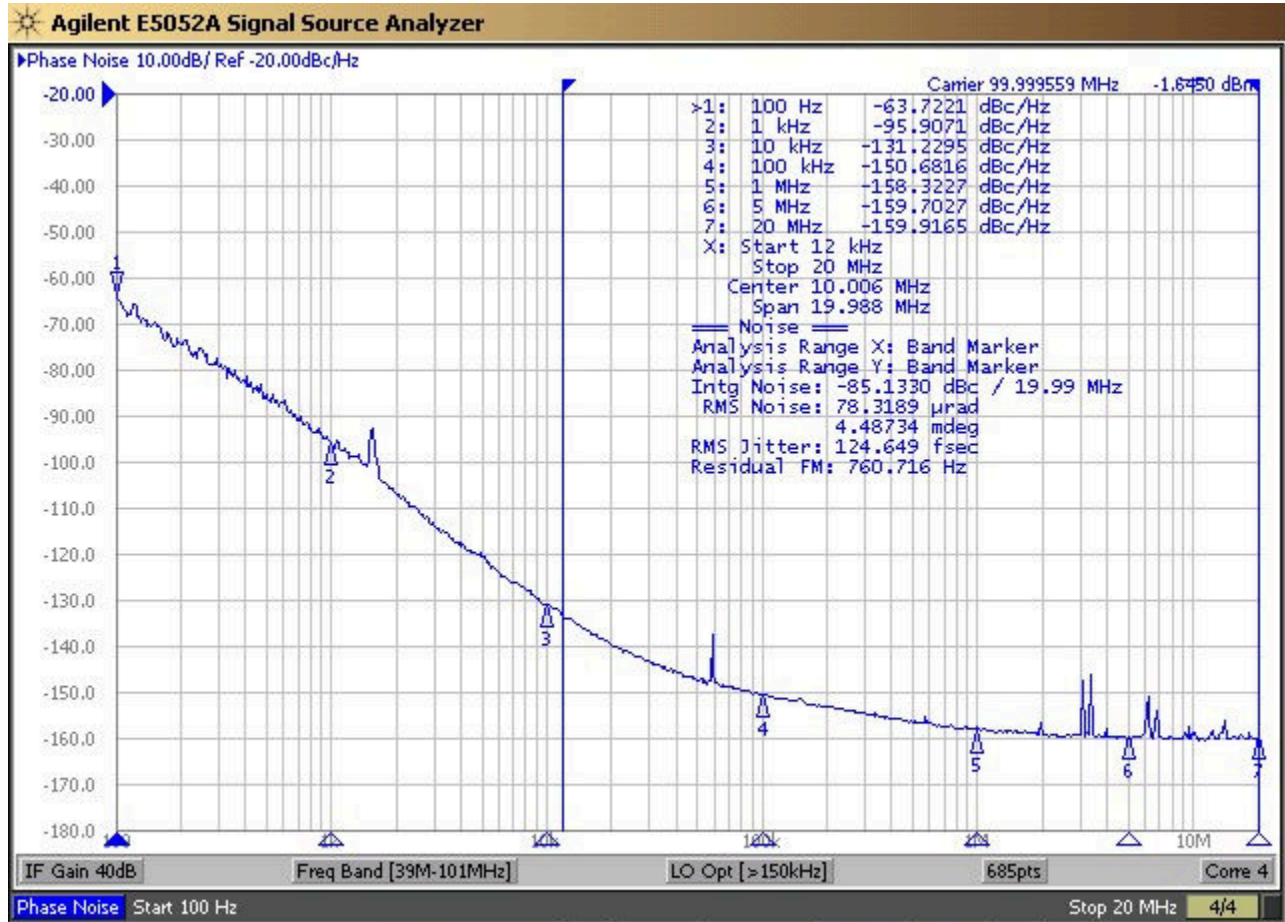
FOD0 Frequency (MHz)	FOD1 Frequency (MHz)s	OUT0 Frequency (MHz) <sup>(2)</sup>	OUT1 Frequency (MHz) <sup>(2)</sup>	Typical OUT0 RMS Jitter (fs) <sup>(3)</sup>	Typical OUT1 RMS Jitter (fs) <sup>(3)</sup>
240	250	24	25	852	716
240	270	24	27	457	371
240	200	24	50	832	779
250	240	25	24	784	717
250	270	25	27	757	787
270	240	27	24	429	367
270	250	27	25	913	641
270	200	27	50	865	930
200	240	50	24	806	548
200	270	50	27	913	704

(1) Measured over 25°C to 105°C using differential LVCMOS output formats using VDD = VDDO\_x = 3.3V, no SSC.

(2) OUT0 and OUT1 are generated using FOD0 and FOD1, respectively.

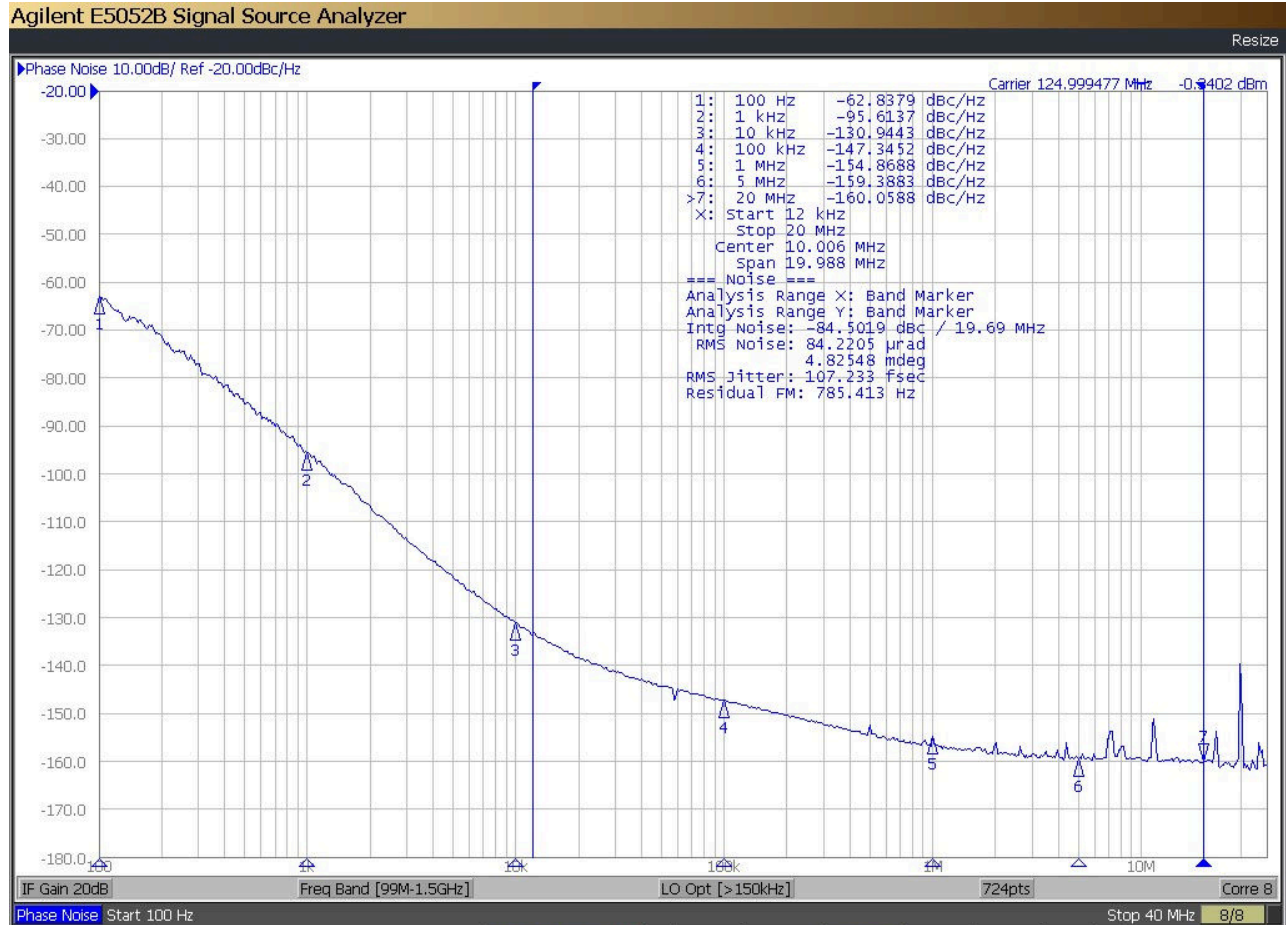
(3) RMS Jitter measured over the 12kHz to 5MHz integration bandwidth.

### 9.2.6 Application Curves



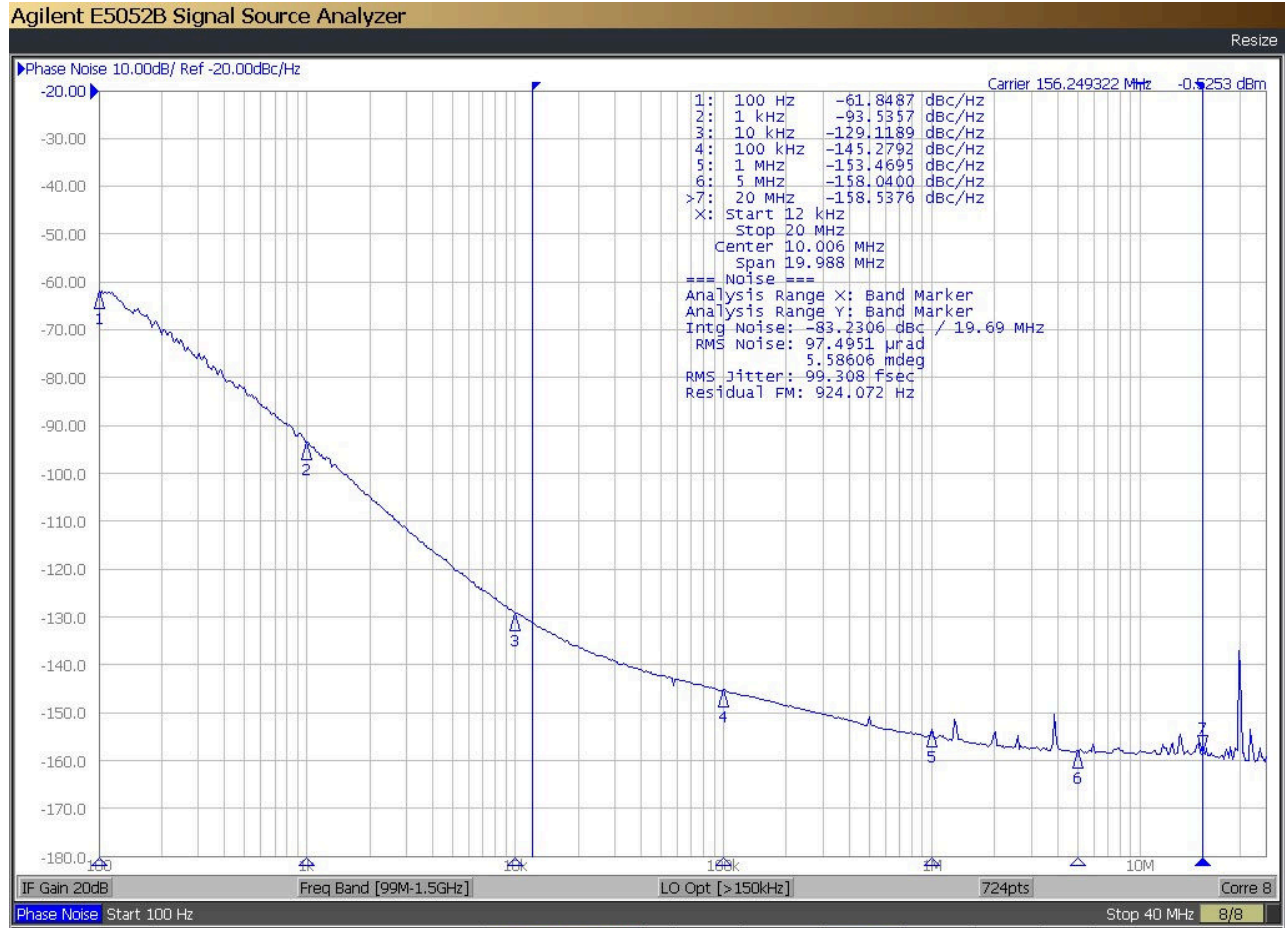
OUT0: 100 MHz LP-HCSL  
 OUT1: 100 MHz LP-HCSL  
 Temperature: 25 °C  
 12k – 20M RMS Jitter: 125 fs

**Figure 9-3. 100MHz LP-HCSL Output for PCIe Application, Measured on OUT0**



OUT0: 125 MHz LP-HCSL  
 OUT1: 125 MHz LP-HCSL  
 Temperature: 25 °C  
 12k – 20M RMS Jitter: 107 fs

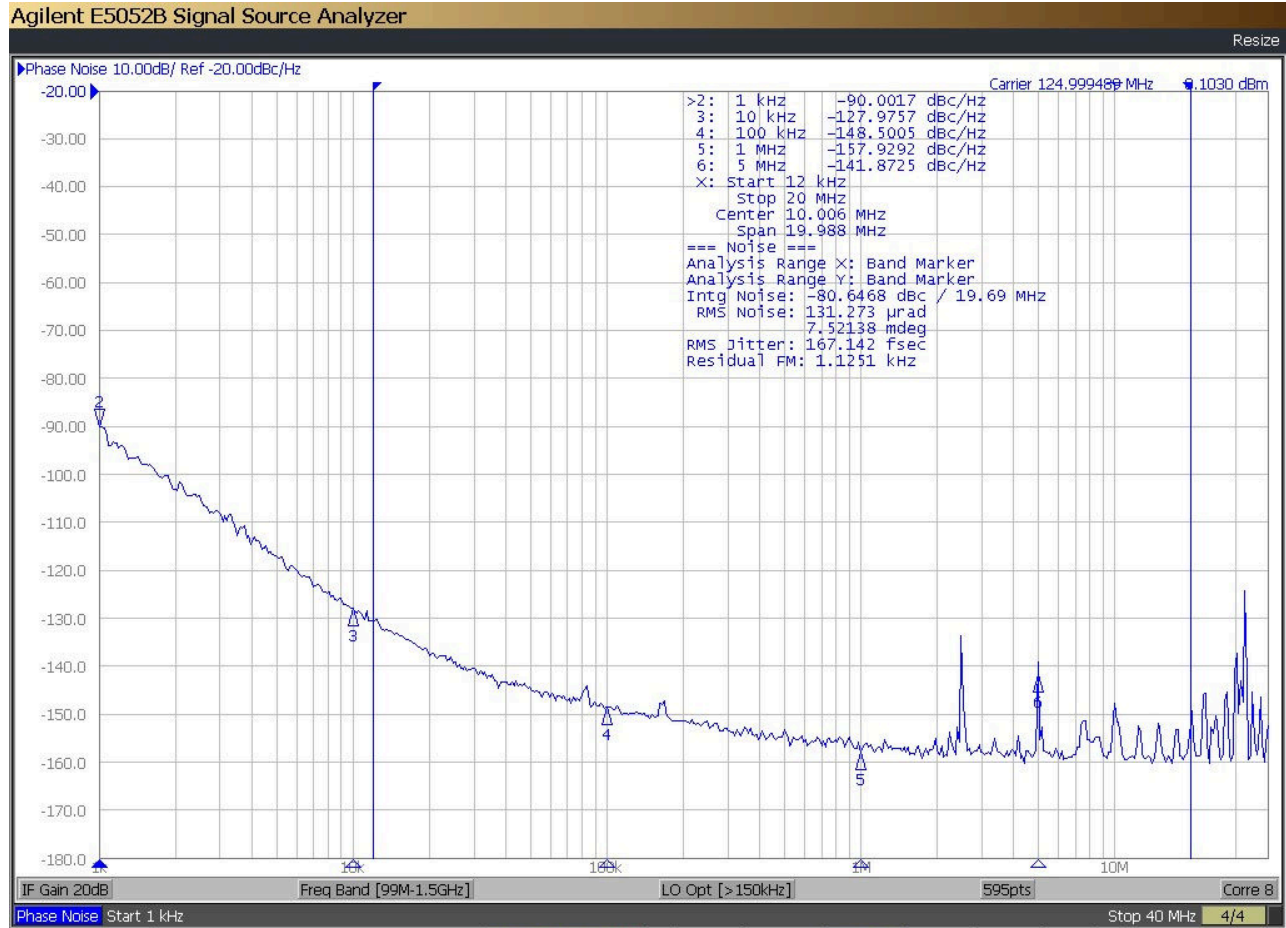
**Figure 9-4. 125MHz LP-HCSL Output, Measured on OUT0**



OUT0: 156.25 MHz LP-HCSL  
 OUT1: 156.25 MHz LP-HCSL  
 Temperature: 25 °C  
 12k – 20M RMS Jitter: 99 fs

**Figure 9-5. 156.25MHz LP-HCSL Output, Measured on OUT0**

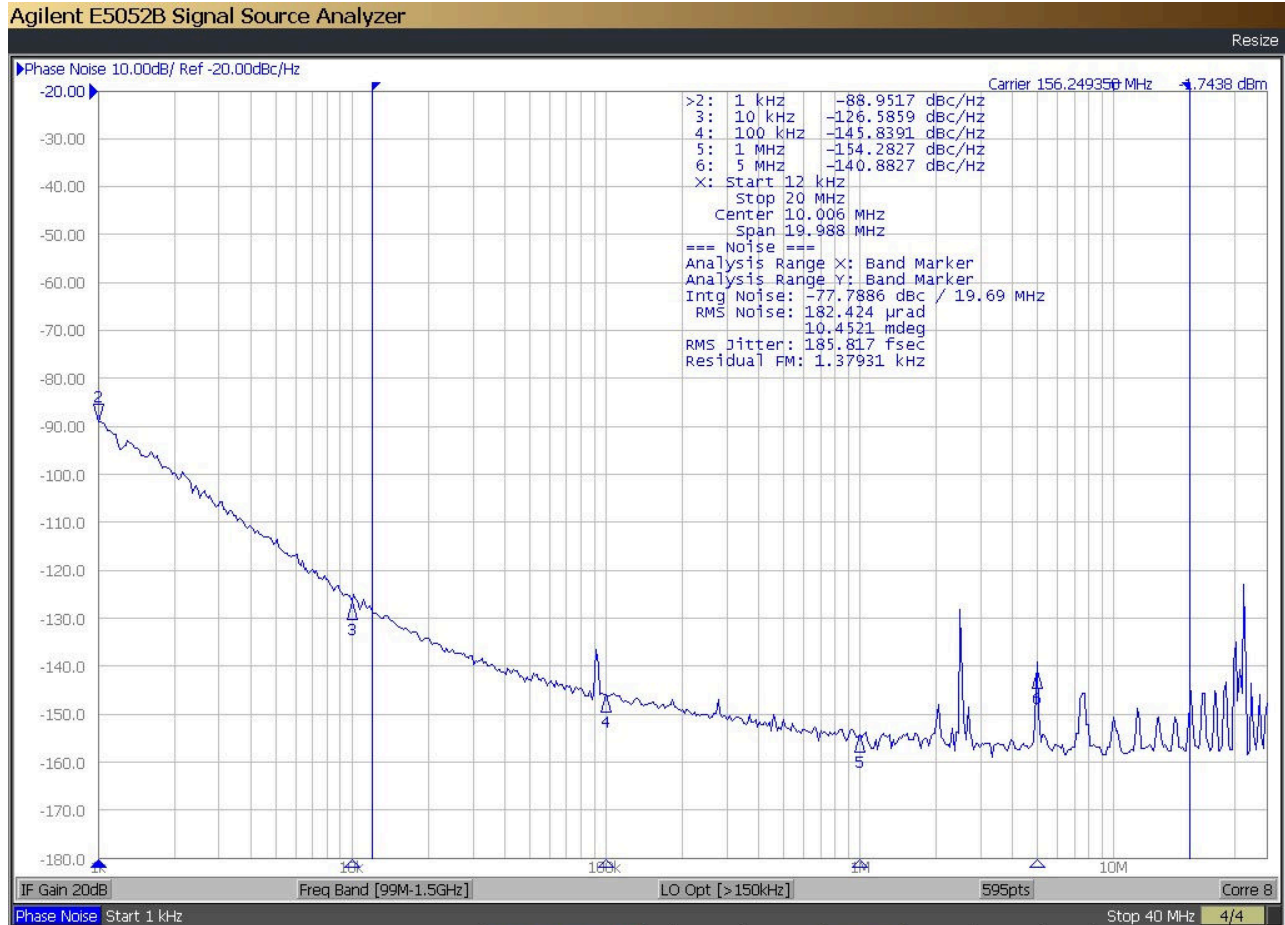




OUT0: 125 MHz LP-HCSL  
 OUT1: 156.25 MHz LP-HCSL  
 Temperature: 25 °C  
 12k – 20M RMS Jitter: 167 fs

**Figure 9-6. 125MHz LP-HCSL on OUT0 With 156.25MHz LP-HCSL on OUT1**

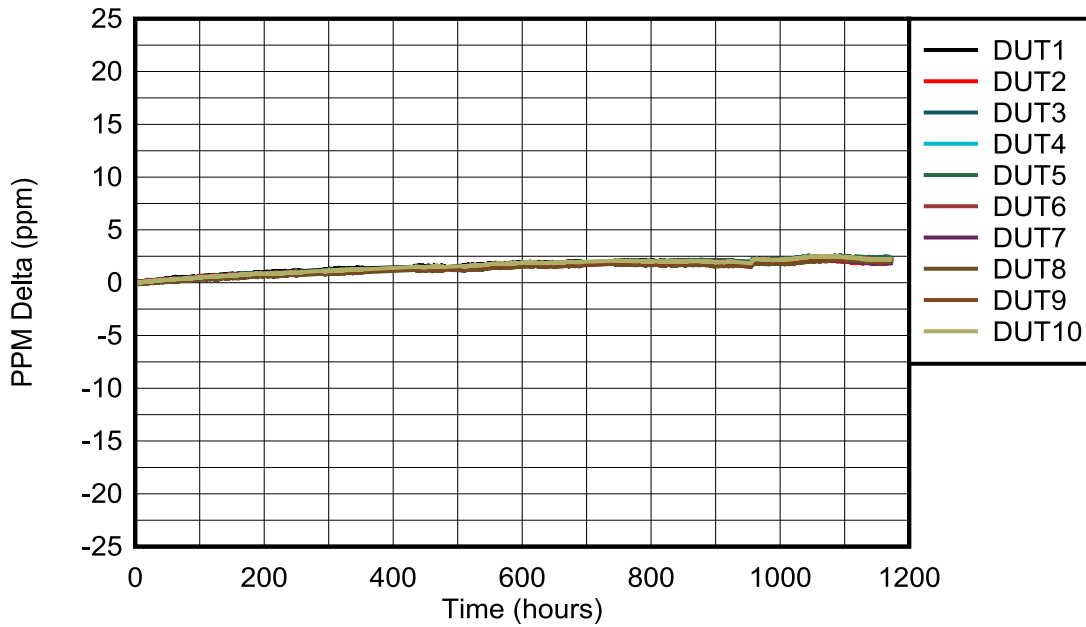




OUT0: 125 MHz LP-HCSL  
 OUT1: 156.25 MHz LP-HCSL  
 Temperature: 25 °C  
 12k – 20M RMS Jitter: 186 fs

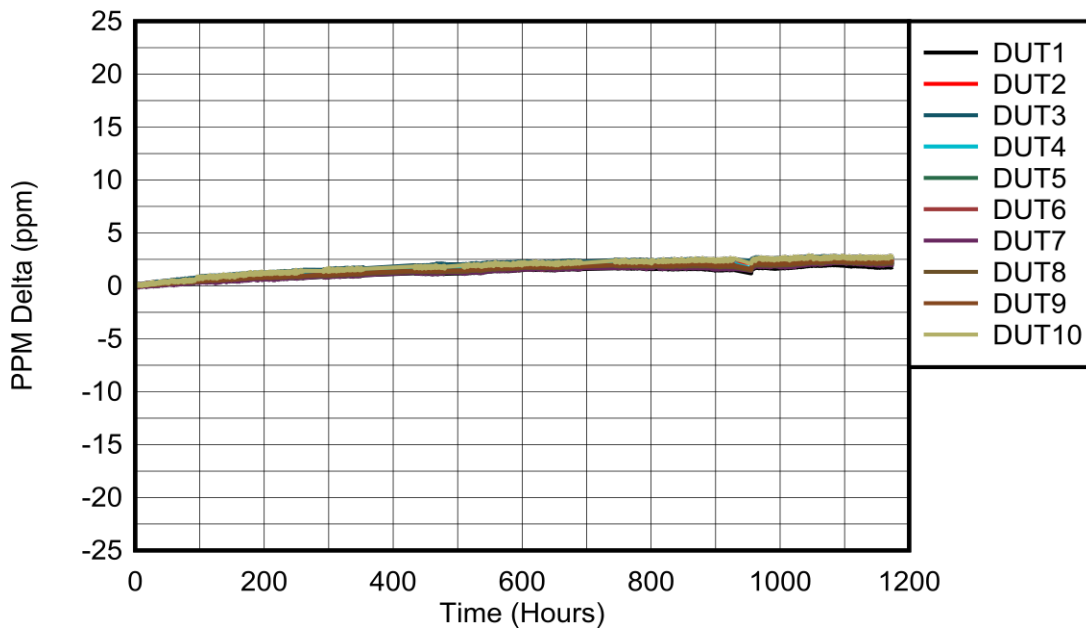
**Figure 9-7. 156.25MHz LP-HCSL on OUT1 With 125MHz LP-HCSL on OUT0**

**PPM over Aging, 1.8V Supply**

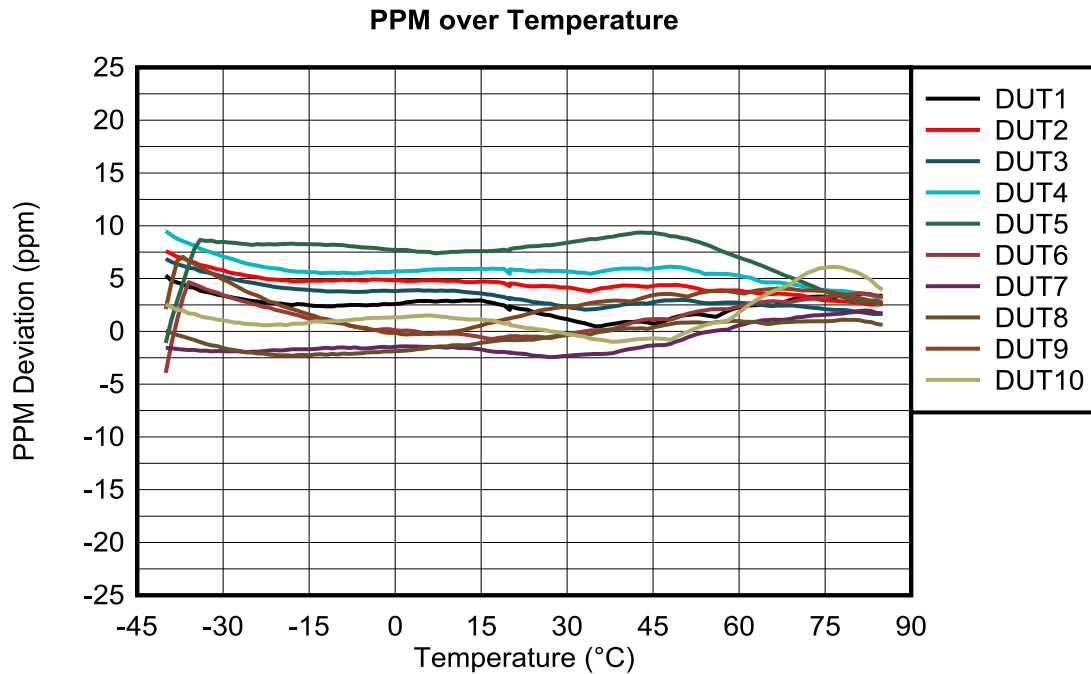


**Figure 9-8. Frequency Stability over Time - 1.8V Supply Voltage**

**PPM over Aging, 3.3V Supply**



**Figure 9-9. Frequency Stability over Time - 3.3V Supply Voltage**



**Figure 9-10. Frequency Stability over Temperature**

## 9.3 Power Supply Recommendations

### 9.3.1 Power-Up Sequencing

The LMK3H0102 provides multiple power supply pins. Each power supply supports 1.8V, 2.5V, or 3.3V. Internal low-dropout regulators (LDO) source the internal blocks and allow each pin to be supplied with individual supply voltages. The VDD pin supplies the control pins, the serial interface, and the REF\_CTRL pin. Therefore, any pullup resistors must be connected to the same domain as VDD.

If an output is not used, connect the corresponding VDDO\_x rail to VDD. If the VDD and VDDO\_x rails are the same voltage, TI recommends connecting these together directly. If VDD and the VDDO\_x rails differ, VDD must ramp first, with VDDO\_x no more than 5ms after.

When using a VDD of 2.5V or 1.8V, VDDO\_x must match VDD. When using a 3.3V VDD, VDDO\_x of 1.8V, 2.5V, or 3.3V is allowed for LP-HCSL outputs. For LVDS outputs, a mismatch between VDD and VDDO\_x can result in a lower common mode voltage than what is specified in the [Electrical Characteristics](#) table. For LVCMOS outputs, using a VDDO\_x that differs from the VDD is not recommended. In the event that VDD and VDDO\_x differ for LVCMOS outputs, the output impedance of the driver can be greater than 17Ω. For single-ended LVCMOS and differential LVCMOS, use a 20Ω or 25Ω series resistor in place of the 33Ω series resistor to maintain 50Ω impedance matching. Do not use In-Phase LVCMOS if the VDDO\_x does not match VDD.

### 9.3.2 Decoupling Power Supply Inputs

Do not tie VDD and VDDO pins to ground. Use a separate ferrite bead to isolate the VDD and the VDDO supplies. If OUT0 and OUT1 are different frequencies, a separate ferrite bead must be used for each VDDO supply. For each supply voltage pin, a 0.1μF or 1μF capacitor must be placed very close to the pin.

## 9.4 Layout

### 9.4.1 Layout Guidelines

For this example, follow these guidelines:

- Isolate outputs using a GND shield. Route all outputs as differential pairs.
- Isolate outputs to adjacent outputs when generating multiple frequencies.
- Avoid impedance jumps in the fan-in and fan-out areas when possible.

- Use five vias to connect the thermal pad to a solid GND plane. Full-through vias are preferred.
- Place decoupling capacitors with small capacitance values very close to the supply pins. Place the decoupling capacitors on the same layer or on the bottom layer directly underneath the device. Larger values can be placed farther away. Ferrite beads are recommended to isolate the different output supplies and the VDD supply.
- Use multiple vias to connect wide supply traces to the respective power planes.

### 9.4.2 Layout Example

Below are printed circuit board (PCB) layout examples that show the application of thermal design practices and a low-inductance ground connection between the device DAP and the PCB.

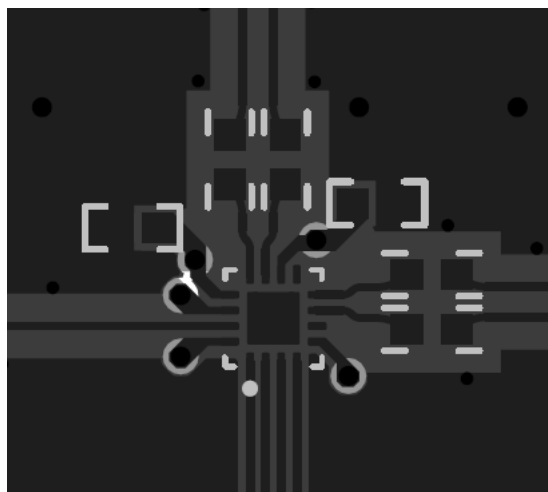


Figure 9-11. PCB Layout Example for LMK3H0102, Top Layer

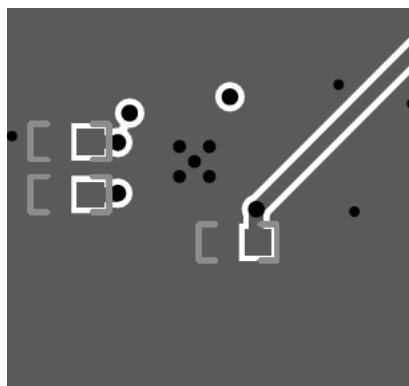


Figure 9-12. PCB Layout Example for LMK3H0102, Bottom Layer

## 10 Device and Documentation Support

TI offers an extensive line of development tools. Tools and software to evaluate the performance of the device, generate code, and develop solutions are listed below.

### 10.1 Documentation Support

#### 10.1.1 Related Documentation

For documentation related to the evaluation module, refer to the [LMK3H0102EVM user's guide](#).

For documentation related to the configuration details of LMK3H0102Axxx devices, refer to the [LMK3H0102 Configuration Guide](#)

### 10.2 Receiving Notification of Documentation Updates

To receive notification of documentation updates, navigate to the device product folder on [ti.com](#). Click on *Notifications* to register and receive a weekly digest of any product information that has changed. For change details, review the revision history included in any revised document.

### 10.3 Support Resources

[TI E2E™ support forums](#) are an engineer's go-to source for fast, verified answers and design help — straight from the experts. Search existing answers or ask your own question to get the quick design help you need.

Linked content is provided "AS IS" by the respective contributors. They do not constitute TI specifications and do not necessarily reflect TI's views; see TI's [Terms of Use](#).

### 10.4 Trademarks

TI E2E™ is a trademark of Texas Instruments.  
All trademarks are the property of their respective owners.

### 10.5 Electrostatic Discharge Caution



This integrated circuit can be damaged by ESD. Texas Instruments recommends that all integrated circuits be handled with appropriate precautions. Failure to observe proper handling and installation procedures can cause damage.

ESD damage can range from subtle performance degradation to complete device failure. Precision integrated circuits may be more susceptible to damage because very small parametric changes could cause the device not to meet its published specifications.

### 10.6 Glossary

[TI Glossary](#) This glossary lists and explains terms, acronyms, and definitions.

## 11 Revision History

NOTE: Page numbers for previous revisions may differ from page numbers in the current version.

<b>Changes from Revision D (March 2025) to Revision E (October 2025)</b>	<b>Page</b>
• Update VDDO_x pin description in <a href="#">Pin Configuration and Functions</a> for split voltage supply.....	3
• Added table note clarifying supply current load conditions for LVCMOS outputs.....	5
• Added PPM data to <a href="#">Application Curves</a> .....	45
• Updated <a href="#">Power-Up Sequencing</a> for split voltage supply.....	51

<b>Changes from Revision C (October 2024) to Revision D (March 2025)</b>	<b>Page</b>
• Added PCIe Gen 7 .....	1
• Updated PCIe Gen 6 to PCIe Gen 7.....	1
• Updated the numbering format for tables, figures, and cross-references throughout the document.....	1

• Added reference to LMK3H0102 Configuration Guide.....	1
• Updated PCIe compliance to Gen 7 throughout the document.....	1
• Added margin to the following specifications: LP-HCSL high level for 2.5V/3.3V from +/-5% to +/-10%, LP-HCSL duty cycle from 49.9% - 50.3% for 100MHz / 48.8% - 50.8% for $f \leq 325\text{MHz}$ / 48.6% - 51.8% for $325\text{MHz} < f \leq 400\text{MHz}$ to 47% - 53% for all cases, LVDS duty cycle from 49% - 51.1% to 47% - 53%, LVDS 20% to 80% differential rise/fall time maximum increased by 5%, PSNR maximum limits increased by 5%. No SSC cycle-to-cycle maximum jitter reduced from 150ps to 20ps. Updated PADCAP_x to OUTx_SLEW_RATE for LVDS rise/fall time.....	5
• Updated image for LP-HCSL configuration during PCIe Test to reflect correct device name.....	14
• Added reference to LMK3H0102 Configuration Guide, updated units to latest standards, added PCIe Gen 7 support.....	16
• Clarified behavior for switching OTP pages in OTP Mode.....	17
• Added clarification on requesting OTP configurations from TI.....	19
• Updated <i>Programming Sequence</i> image to reflect OTP_AUTOLOAD_DIS = 1 instead of OTP_AUTOLOAD_DIS = 0.....	20
• Corrected description of ADC_CLK_N_DIV to show 0x99 instead of 0x9B.....	32
• Updated default value of OUT0_SLEW_RATE from 0x3 to 0x0. Updated reset value of R6 from 0x2AA0 to 0x0AA0.....	34
• Updated default value of REF_CTRL_PIN_FUNC from 0x1 to 0x3. Updated default value of OUT0_EN from 0x0 to 0x1. Updated default value of OUT1_EN from 0x0 to 0x1.....	34
• Updated default value of OUT1_LPHSCL_AMP_SEL from 0x3 to 0x6. Removed extra period in the description of OUT_FMT_SRC_SEL. Added note that OTP_ID is 1 for the V18 configuration.....	36
• Updated default value of R12 from 0x6800 to 0xE800. Updated default value of I2C_ADDR_LSB_SEL from 0x0 to 0x1.....	38
• Updated instances of REF_CLK to REF_CTRL to align with pin names.....	41
• Changed REF_CLK frequency from 33MHz to 25MHz to match diagram.....	41
• Updated instance of CHO_FOD_SEL to CH0_FOD_SEL. Updated REF_CLK to 25MHz in place of 33MHz for example calculation.....	42
• Changed "more far away" to "farther away".....	51
• Added reference to LMK3H0102 Configuration Guide.....	53

<b>Changes from Revision B (June 2024) to Revision C (October 2024)</b>	<b>Page</b>
• Changed data sheet status from Advanced Information to Production Data.....	1
• Updated the number formatting for tables, figures, and cross-references throughout the document.....	1

<b>Changes from Revision A (December 2023) to Revision B (June 2024)</b>	<b>Page</b>
• Updated the number formatting for tables, figures, and cross-references throughout the document.....	1

<b>Changes from Revision * (November 2023) to Revision A (December 2023)</b>	<b>Page</b>
• Clarified preconfigured SSC options, fixed functional safety link.....	1
• Clarified pin behavior.....	1
• Updated the number formatting for tables, figures, and cross-references throughout the document.....	1

## 12 Mechanical, Packaging, and Orderable Information

The following pages include mechanical, packaging, and orderable information. This information is the most current data available for the designated devices. This data is subject to change without notice and revision of this document. For browser-based versions of this data sheet, refer to the left-hand navigation.

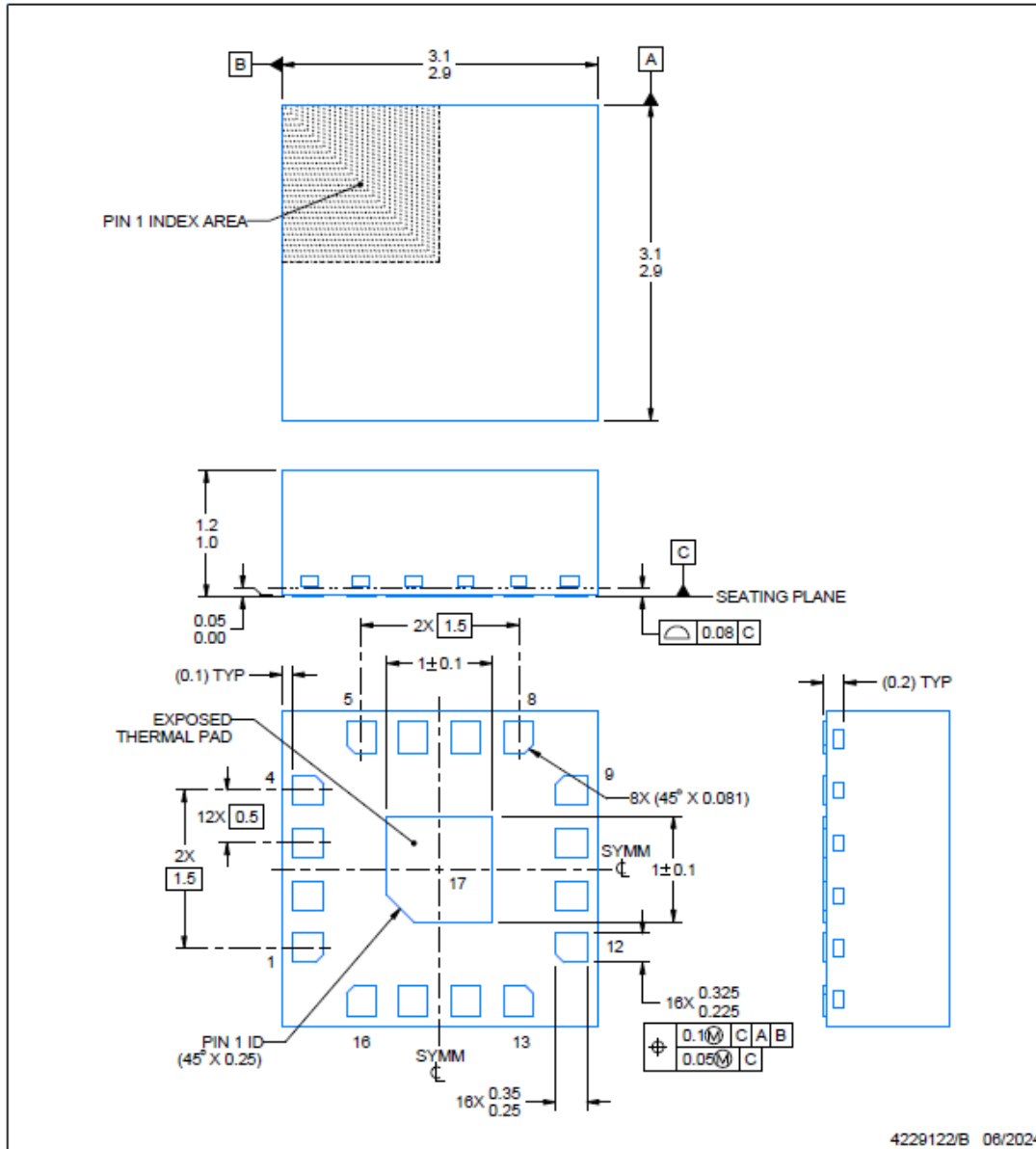


**RER0016A**

**PACKAGE OUTLINE**

**TQFN - 1.2 mm max height**

PLASTIC QUAD FLATPACK - NO LEAD



**NOTES:**

1. All linear dimensions are in millimeters. Any dimensions in parenthesis are for reference only. Dimensioning and tolerancing per ASME Y14.5M.
2. This drawing is subject to change without notice.
3. The package thermal pad must be soldered to the printed circuit board for optimal thermal and mechanical performance.

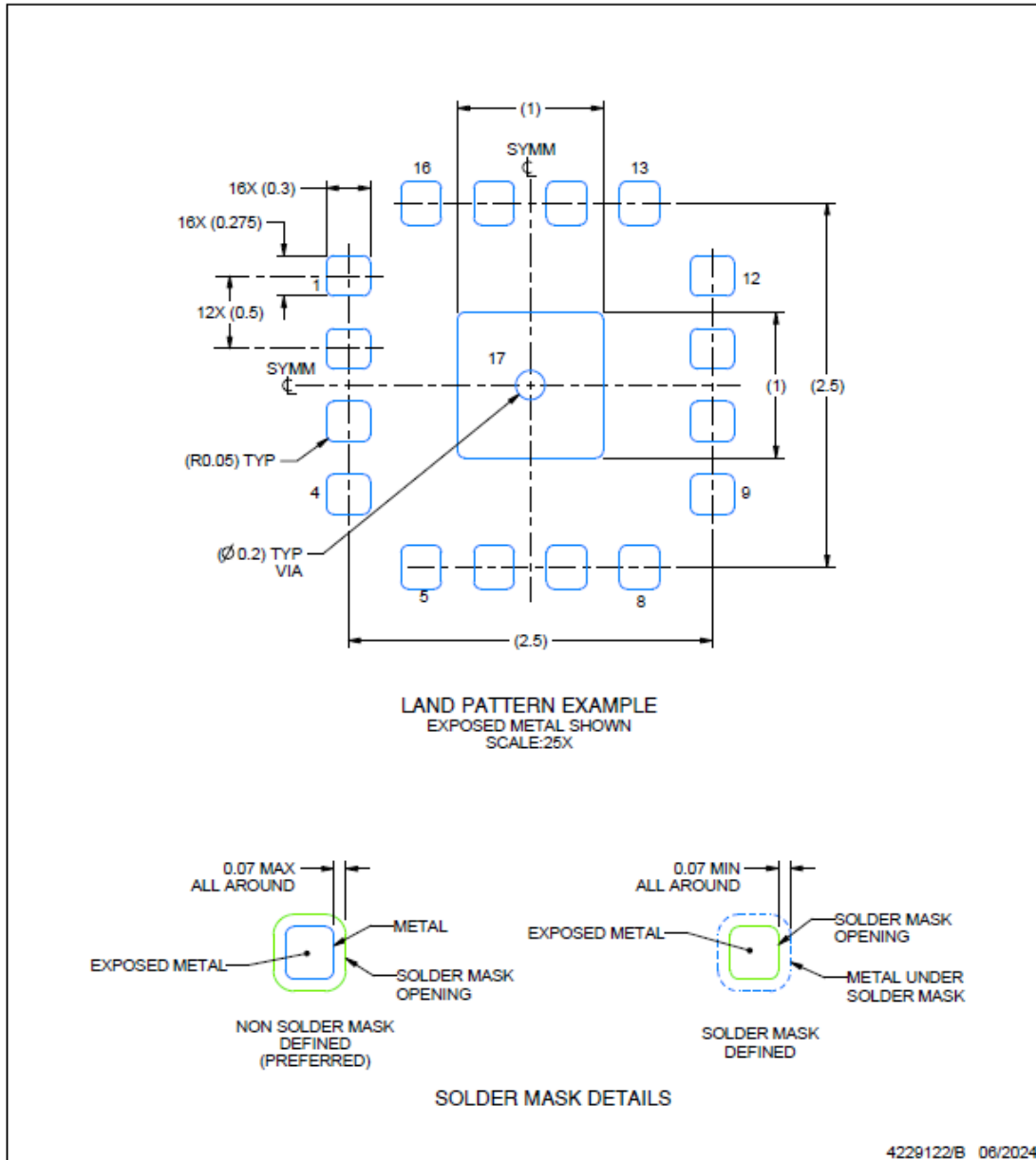


## EXAMPLE BOARD LAYOUT

RER0016A

TQFN - 1.2 mm max height

PLASTIC QUAD FLATPACK - NO LEAD



NOTES: (continued)

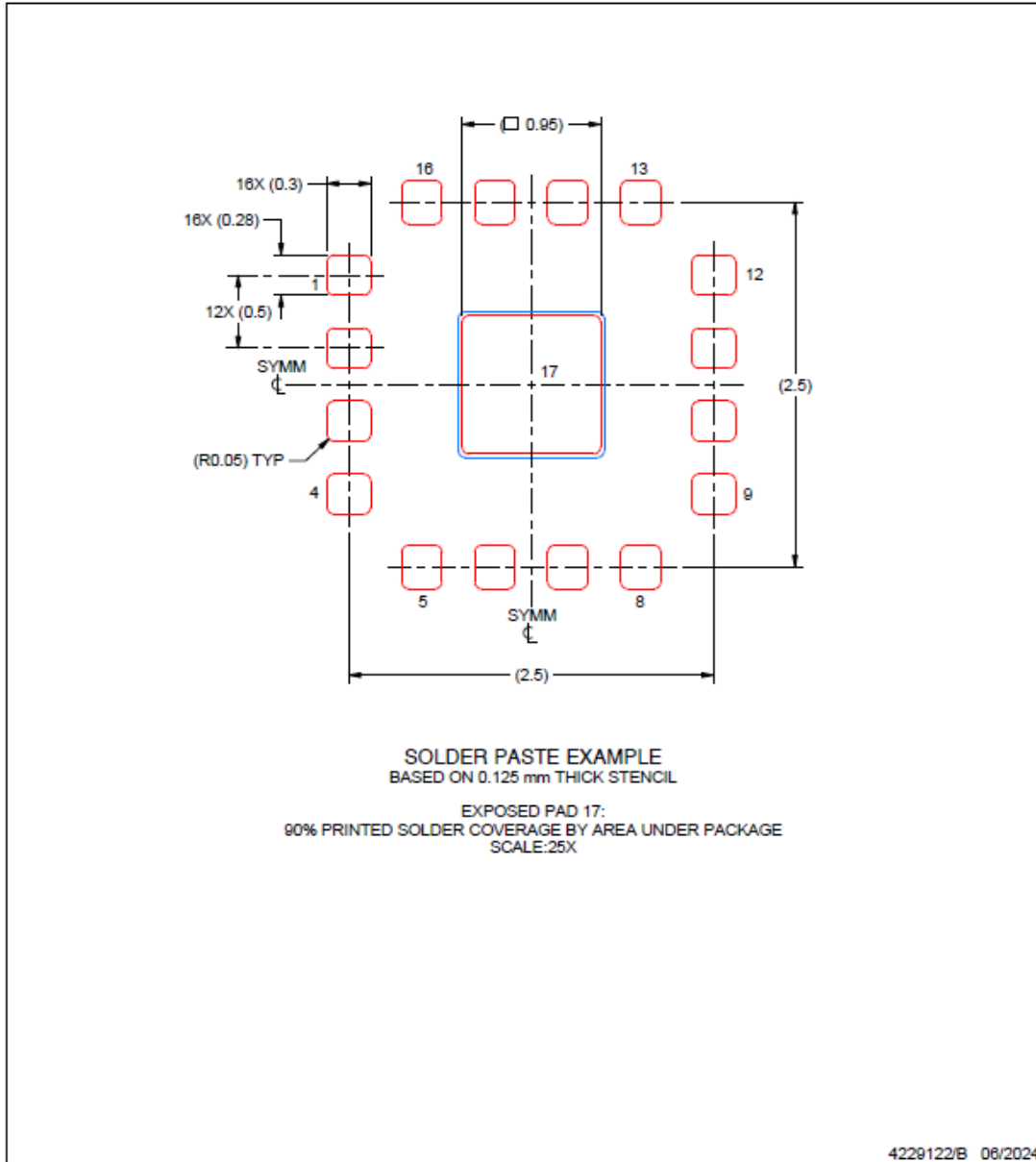
- This package is designed to be soldered to a thermal pad on the board. For more information, see Texas Instruments literature number SLUA271 ([www.ti.com/lit/sluea271](http://www.ti.com/lit/sluea271)).
- Vias are optional depending on application, refer to device data sheet. It is recommended that vias under paste be filled, plugged or tented.

**EXAMPLE STENCIL DESIGN**

**RER0016A**

**TQFN - 1.2 mm max height**

PLASTIC QUAD FLATPACK - NO LEAD



NOTES: (continued)

- 6. Laser cutting apertures with trapezoidal walls and rounded corners may offer better paste release. IPC-7525 may have alternate design recommendations.

**PACKAGING INFORMATION**

Orderable part number	Status (1)	Material type (2)	Package   Pins	Package qty   Carrier	RoHS (3)	Lead finish/ Ball material (4)	MSL rating/ Peak reflow (5)	Op temp (°C)	Part marking (6)
<a href="#">LMK3H0102A001RERR</a>	Active	Production	TQFN (RER)   16	3000   LARGE T&R	Yes	Call TI	Level-2-260C-1 YEAR	-40 to 85	3HA001
LMK3H0102A001RERR.A	Active	Production	TQFN (RER)   16	3000   LARGE T&R	Yes	Call TI	Level-2-260C-1 YEAR	-40 to 85	3HA001
<a href="#">LMK3H0102A002RERR</a>	Active	Production	TQFN (RER)   16	3000   LARGE T&R	Yes	Call TI	Level-2-260C-1 YEAR	-40 to 85	3HA002
<a href="#">LMK3H0102A006RERR</a>	Active	Production	TQFN (RER)   16	3000   LARGE T&R	Yes	Call TI	Level-2-260C-1 YEAR	-40 to 85	3HA006
LMK3H0102A006RERR.A	Active	Production	TQFN (RER)   16	3000   LARGE T&R	Yes	Call TI	Level-2-260C-1 YEAR	-40 to 85	3HA006
<a href="#">LMK3H0102A014RERR</a>	Active	Production	TQFN (RER)   16	3000   LARGE T&R	Yes	Call TI	Level-2-260C-1 YEAR	-40 to 85	3HA014
LMK3H0102A014RERR.A	Active	Production	TQFN (RER)   16	3000   LARGE T&R	Yes	Call TI	Level-2-260C-1 YEAR	-40 to 85	3HA014
<a href="#">LMK3H0102A015RERR</a>	Active	Production	TQFN (RER)   16	3000   LARGE T&R	Yes	Call TI	Level-2-260C-1 YEAR	-40 to 85	3HA015
LMK3H0102A015RERR.A	Active	Production	TQFN (RER)   16	3000   LARGE T&R	Yes	Call TI	Level-2-260C-1 YEAR	-40 to 85	3HA015
<a href="#">LMK3H0102A016RERR</a>	Active	Production	TQFN (RER)   16	3000   LARGE T&R	Yes	Call TI	Level-2-260C-1 YEAR	-40 to 85	3HA016
<a href="#">LMK3H0102A018RERR</a>	Active	Production	TQFN (RER)   16	3000   LARGE T&R	Yes	Call TI	Level-2-260C-1 YEAR	-40 to 85	3HA018
<a href="#">LMK3H0102A01DRERR</a>	Active	Production	TQFN (RER)   16	3000   LARGE T&R	Yes	Call TI	Level-2-260C-1 YEAR	-40 to 85	3HA01D
<a href="#">LMK3H0102A01ERERR</a>	Active	Production	TQFN (RER)   16	3000   LARGE T&R	Yes	Call TI	Level-2-260C-1 YEAR	-40 to 85	3HA01E
<a href="#">LMK3H0102A022RERR</a>	Active	Production	TQFN (RER)   16	3000   LARGE T&R	Yes	Call TI	Level-2-260C-1 YEAR	-40 to 85	3HA022
<a href="#">LMK3H0102A023RERR</a>	Active	Production	TQFN (RER)   16	3000   LARGE T&R	Yes	Call TI	Level-2-260C-1 YEAR	-40 to 85	3HA023
<a href="#">LMK3H0102V18RERR</a>	Active	Production	TQFN (RER)   16	3000   LARGE T&R	Yes	Call TI	Level-2-260C-1 YEAR	-40 to 85	3HV18
LMK3H0102V18RERR.A	Active	Production	TQFN (RER)   16	3000   LARGE T&R	Yes	Call TI	Level-2-260C-1 YEAR	-40 to 85	3HV18
<a href="#">LMK3H0102V33RERR</a>	Active	Production	TQFN (RER)   16	3000   LARGE T&R	Yes	Call TI	Level-2-260C-1 YEAR	-40 to 85	3HV33
LMK3H0102V33RERR.A	Active	Production	TQFN (RER)   16	3000   LARGE T&R	Yes	Call TI	Level-2-260C-1 YEAR	-40 to 85	3HV33

(1) **Status:** For more details on status, see our [product life cycle](#).

(2) **Material type:** When designated, preproduction parts are prototypes/experimental devices, and are not yet approved or released for full production. Testing and final process, including without limitation quality assurance, reliability performance testing, and/or process qualification, may not yet be complete, and this item is subject to further changes or possible discontinuation. If available for ordering, purchases will be subject to an additional waiver at checkout, and are intended for early internal evaluation purposes only. These items are sold without warranties of any kind.

(3) **RoHS values:** Yes, No, RoHS Exempt. See the [TI RoHS Statement](#) for additional information and value definition.

(4) **Lead finish/Ball material:** Parts may have multiple material finish options. Finish options are separated by a vertical ruled line. Lead finish/Ball material values may wrap to two lines if the finish value exceeds the maximum column width.

<sup>(5)</sup> **MSL rating/Peak reflow:** The moisture sensitivity level ratings and peak solder (reflow) temperatures. In the event that a part has multiple moisture sensitivity ratings, only the lowest level per JEDEC standards is shown. Refer to the shipping label for the actual reflow temperature that will be used to mount the part to the printed circuit board.

<sup>(6)</sup> **Part marking:** There may be an additional marking, which relates to the logo, the lot trace code information, or the environmental category of the part.

Multiple part markings will be inside parentheses. Only one part marking contained in parentheses and separated by a "~" will appear on a part. If a line is indented then it is a continuation of the previous line and the two combined represent the entire part marking for that device.

**Important Information and Disclaimer:** The information provided on this page represents TI's knowledge and belief as of the date that it is provided. TI bases its knowledge and belief on information provided by third parties, and makes no representation or warranty as to the accuracy of such information. Efforts are underway to better integrate information from third parties. TI has taken and continues to take reasonable steps to provide representative and accurate information but may not have conducted destructive testing or chemical analysis on incoming materials and chemicals. TI and TI suppliers consider certain information to be proprietary, and thus CAS numbers and other limited information may not be available for release.

In no event shall TI's liability arising out of such information exceed the total purchase price of the TI part(s) at issue in this document sold by TI to Customer on an annual basis.

**OTHER QUALIFIED VERSIONS OF LMK3H0102 :**

- Automotive : [LMK3H0102-Q1](#)

NOTE: Qualified Version Definitions:

- Automotive - Q100 devices qualified for high-reliability automotive applications targeting zero defects

**TAPE AND REEL INFORMATION**

**QUADRANT ASSIGNMENTS FOR PIN 1 ORIENTATION IN TAPE**


\*All dimensions are nominal

Device	Package Type	Package Drawing	Pins	SPQ	Reel Diameter (mm)	Reel Width W1 (mm)	A0 (mm)	B0 (mm)	K0 (mm)	P1 (mm)	W (mm)	Pin1 Quadrant
LMK3H0102A001RERR	TQFN	RER	16	3000	330.0	12.4	3.3	3.3	1.35	8.0	12.0	Q1
LMK3H0102A002RERR	TQFN	RER	16	3000	330.0	12.4	3.3	3.3	1.35	8.0	12.0	Q1
LMK3H0102A006RERR	TQFN	RER	16	3000	330.0	12.4	3.3	3.3	1.35	8.0	12.0	Q1
LMK3H0102A014RERR	TQFN	RER	16	3000	330.0	12.4	3.3	3.3	1.35	8.0	12.0	Q1
LMK3H0102A015RERR	TQFN	RER	16	3000	330.0	12.4	3.3	3.3	1.35	8.0	12.0	Q1
LMK3H0102A016RERR	TQFN	RER	16	3000	330.0	12.4	3.3	3.3	1.35	8.0	12.0	Q1
LMK3H0102A018RERR	TQFN	RER	16	3000	330.0	12.4	3.3	3.3	1.35	8.0	12.0	Q1
LMK3H0102A01DRERR	TQFN	RER	16	3000	330.0	12.4	3.3	3.3	1.35	8.0	12.0	Q1
LMK3H0102A01ERERR	TQFN	RER	16	3000	330.0	12.4	3.3	3.3	1.35	8.0	12.0	Q1
LMK3H0102A022RERR	TQFN	RER	16	3000	330.0	12.4	3.3	3.3	1.35	8.0	12.0	Q1
LMK3H0102A023RERR	TQFN	RER	16	3000	330.0	12.4	3.3	3.3	1.35	8.0	12.0	Q1
LMK3H0102V18RERR	TQFN	RER	16	3000	330.0	12.4	3.3	3.3	1.35	8.0	12.0	Q1
LMK3H0102V33RERR	TQFN	RER	16	3000	330.0	12.4	3.3	3.3	1.35	8.0	12.0	Q1

**TAPE AND REEL BOX DIMENSIONS**


\*All dimensions are nominal

Device	Package Type	Package Drawing	Pins	SPQ	Length (mm)	Width (mm)	Height (mm)
LMK3H0102A001RERR	TQFN	RER	16	3000	346.0	346.0	33.0
LMK3H0102A002RERR	TQFN	RER	16	3000	346.0	346.0	33.0
LMK3H0102A006RERR	TQFN	RER	16	3000	346.0	346.0	33.0
LMK3H0102A014RERR	TQFN	RER	16	3000	346.0	346.0	33.0
LMK3H0102A015RERR	TQFN	RER	16	3000	346.0	346.0	33.0
LMK3H0102A016RERR	TQFN	RER	16	3000	346.0	346.0	33.0
LMK3H0102A018RERR	TQFN	RER	16	3000	346.0	346.0	33.0
LMK3H0102A01DRERR	TQFN	RER	16	3000	346.0	346.0	33.0
LMK3H0102A01ERERR	TQFN	RER	16	3000	346.0	346.0	33.0
LMK3H0102A022RERR	TQFN	RER	16	3000	346.0	346.0	33.0
LMK3H0102A023RERR	TQFN	RER	16	3000	346.0	346.0	33.0
LMK3H0102V18RERR	TQFN	RER	16	3000	346.0	346.0	33.0
LMK3H0102V33RERR	TQFN	RER	16	3000	346.0	346.0	33.0

## IMPORTANT NOTICE AND DISCLAIMER

TI PROVIDES TECHNICAL AND RELIABILITY DATA (INCLUDING DATASHEETS), DESIGN RESOURCES (INCLUDING REFERENCE DESIGNS), APPLICATION OR OTHER DESIGN ADVICE, WEB TOOLS, SAFETY INFORMATION, AND OTHER RESOURCES "AS IS" AND WITH ALL FAULTS, AND DISCLAIMS ALL WARRANTIES, EXPRESS AND IMPLIED, INCLUDING WITHOUT LIMITATION ANY IMPLIED WARRANTIES OF MERCHANTABILITY, FITNESS FOR A PARTICULAR PURPOSE OR NON-INFRINGEMENT OF THIRD PARTY INTELLECTUAL PROPERTY RIGHTS.

These resources are intended for skilled developers designing with TI products. You are solely responsible for (1) selecting the appropriate TI products for your application, (2) designing, validating and testing your application, and (3) ensuring your application meets applicable standards, and any other safety, security, regulatory or other requirements.

These resources are subject to change without notice. TI grants you permission to use these resources only for development of an application that uses the TI products described in the resource. Other reproduction and display of these resources is prohibited. No license is granted to any other TI intellectual property right or to any third party intellectual property right. TI disclaims responsibility for, and you fully indemnify TI and its representatives against any claims, damages, costs, losses, and liabilities arising out of your use of these resources.

TI's products are provided subject to [TI's Terms of Sale](#), [TI's General Quality Guidelines](#), or other applicable terms available either on [ti.com](#) or provided in conjunction with such TI products. TI's provision of these resources does not expand or otherwise alter TI's applicable warranties or warranty disclaimers for TI products. Unless TI explicitly designates a product as custom or customer-specified, TI products are standard, catalog, general purpose devices.

TI objects to and rejects any additional or different terms you may propose.

Copyright © 2026, Texas Instruments Incorporated

Last updated 10/2025