

# SN74AXC8T245 8-Bit Dual-Supply Bus Transceiver With Configurable Voltage Translation and Tri-State Outputs

## 1 Features

- Qualified fully configurable dual-rail design allows each port to operate with a power supply range from 0.65V to 3.6V
- Operating temperature from  $-40^{\circ}\text{C}$  to  $+125^{\circ}\text{C}$
- Multiple direction-control pins to allow simultaneous up and down translation
- Up to 380Mbps support when translating from 1.8V to 3.3V
- $V_{CC}$  isolation feature to effectively isolate both buses in a power-down scenario
- Partial power-down mode to limit backflow current in a power-down scenario
- Compatible with SN74AVC8T245 and 74AVC8T245 level shifters
- Latch-up performance exceeds 100mA per JESD 78, class II
- ESD protection exceeds JESD 22
  - 8000-V human-body model
  - 1000-V charged-device model

## 2 Applications

- [Enterprise and communications](#)
- [Industrial](#)
- [Personal electronics](#)
- [Wireless infrastructure](#)
- [Building automation](#)
- [Point of sale](#)

## 3 Description

The SN74AXC8T245 device is an 8-bit non-inverting bus transceiver that resolves voltage level mismatch between devices operating at the latest voltage nodes (0.7V, 0.8V, and 0.9V) and devices operating at industry standard voltage nodes (1.8V, 2.5V, and 3.3V) and vice versa.

The device operates by using two independent power-supply rails ( $V_{CCA}$  and  $V_{CCB}$ ) that operate as low as 0.65V. Data pins A1 through A8 are designed to track  $V_{CCA}$ , which accepts any supply voltage from 0.65V to 3.6V. Data pins B1 through B8 are designed to track  $V_{CCB}$ , which accepts any supply voltage from 0.65V to 3.6V.

The SN74AXC8T245 device is designed for asynchronous communication between data buses. The device transmits data from the A bus to the B bus or from the B bus to the A bus, depending on the logic level of the direction-control inputs (DIR1 and DIR2). The output-enable ( $\overline{OE}$ ) input is used to disable the outputs so the buses are effectively isolated.

The SN74AXC8T245 device is designed so the control pins (DIR and  $\overline{OE}$ ) are referenced to  $V_{CCA}$ .

This device is fully specified for partial-power-down applications using  $I_{off}$ . The  $I_{off}$  circuitry disables the outputs when the device is powered down. This inhibits current backflow into the device which prevents damage to the device.

The  $V_{CC}$  isolation feature is designed so that if either  $V_{CC}$  input supply is below 100mV, all level shifter outputs are disabled and placed into a high-impedance state.

To put the level shifter I/Os in the high-impedance state during power up or power down, tie  $\overline{OE}$  to  $V_{CCA}$  through a pullup resistor; the current-sinking capability of the driver determines the minimum value of the resistor.

### Package Information

PART NUMBER	PACKAGE <sup>(1)</sup>	PACKAGE SIZE <sup>(2)</sup>
SN74AXC8T245	PW (TSSOP, 24)	7.8mm × 6.4mm
	RHL (VQFN, 24)	5.5mm × 3.5mm
	RJW (UQFN, 24)	4mm × 2mm

(1) For more information, see [Section 11](#)

(2) The package size (length × width) is a nominal value and includes pins, where applicable.

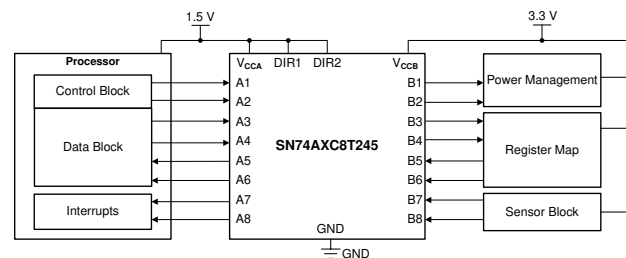

Typical Application Schematic



## Table of Contents

<b>1 Features</b> .....	1	<b>7 Detailed Description</b> .....	19
<b>2 Applications</b> .....	1	7.1 Overview.....	19
<b>3 Description</b> .....	1	7.2 Functional Block Diagram.....	19
<b>4 Pin Configuration and Functions</b> .....	2	7.3 Feature Description.....	20
<b>5 Specifications</b> .....	4	7.4 Device Functional Modes.....	20
5.1 Absolute Maximum Ratings.....	4	<b>8 Application and Implementation</b> .....	21
5.2 ESD Ratings.....	4	8.1 Application Information.....	21
5.3 Recommended Operating Conditions.....	5	8.2 Typical Application.....	21
5.4 Thermal Information.....	5	8.3 Power Supply Recommendations.....	23
5.5 Electrical Characteristics.....	6	8.4 Layout.....	23
5.6 Switching Characteristics, $V_{CCA} = 0.7V$ .....	7	<b>9 Device and Documentation Support</b> .....	24
5.7 Switching Characteristics, $V_{CCA} = 0.8V$ .....	8	9.1 Documentation Support.....	24
5.8 Switching Characteristics, $V_{CCA} = 0.9V$ .....	9	9.2 Receiving Notification of Documentation Updates.....	24
5.9 Switching Characteristics, $V_{CCA} = 1.2V$ .....	10	9.3 Support Resources.....	24
5.10 Switching Characteristics, $V_{CCA} = 1.5V$ .....	11	9.4 Trademarks.....	24
5.11 Switching Characteristics, $V_{CCA} = 1.8V$ .....	12	9.5 Electrostatic Discharge Caution.....	24
5.12 Switching Characteristics, $V_{CCA} = 2.5V$ .....	13	9.6 Glossary.....	24
5.13 Switching Characteristics, $V_{CCA} = 3.3V$ .....	14	<b>10 Revision History</b> .....	24
5.14 Operating Characteristics: $T_A = 25^\circ C$ .....	15	<b>11 Mechanical, Packaging, and Orderable Information</b> .....	24
<b>6 Parameter Measurement Information</b> .....	17		

## 4 Pin Configuration and Functions

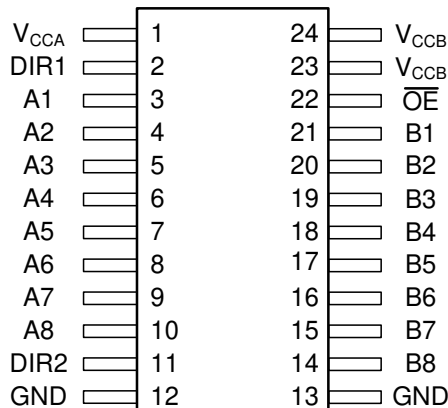
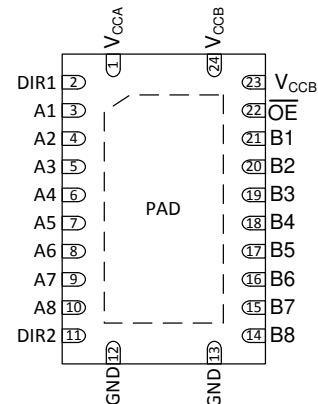
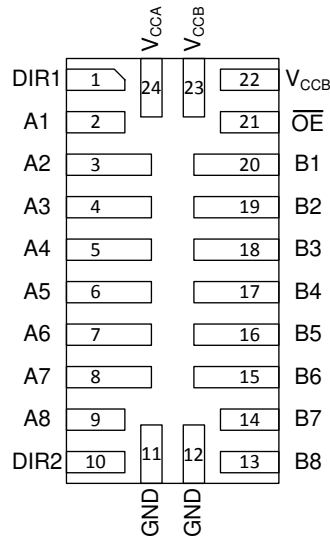

Figure 4-1. PW Package, 24-Pin TSSOP (Top View)



PAD — may be grounded (recommended) or left floating.

Figure 4-2. RHL 24-Pin VQFN (Top View)



**Figure 4-3. RJW Package, 24-Pin UQFN (Top View)**

**Table 4-1. Pin Functions**

PIN			TYPE <sup>(1)</sup>	DESCRIPTION
NAME	PW, RHL	RJW		
A1	3	2	I/O	Input/output A1. Referenced to $V_{CCA}$ .
A2	4	3	I/O	Input/output A2. Referenced to $V_{CCA}$ .
A3	5	4	I/O	Input/output A3. Referenced to $V_{CCA}$ .
A4	6	5	I/O	Input/output A4. Referenced to $V_{CCA}$ .
A5	7	6	I/O	Input/output A5. Referenced to $V_{CCA}$ .
A6	8	7	I/O	Input/output A6. Referenced to $V_{CCA}$ .
A7	9	8	I/O	Input/output A7. Referenced to $V_{CCA}$ .
A8	10	9	I/O	Input/output A8. Referenced to $V_{CCA}$ .
B1	21	20	I/O	Input/output B1. Referenced to $V_{CCB}$ .
B2	20	19	I/O	Input/output B2. Referenced to $V_{CCB}$ .
B3	19	18	I/O	Input/output B3. Referenced to $V_{CCB}$ .
B4	18	17	I/O	Input/output B4. Referenced to $V_{CCB}$ .
B5	17	16	I/O	Input/output B5. Referenced to $V_{CCB}$ .
B6	16	15	I/O	Input/output B6. Referenced to $V_{CCB}$ .
B7	15	14	I/O	Input/output B7. Referenced to $V_{CCB}$ .
B8	14	13	I/O	Input/output B8. Referenced to $V_{CCB}$ .
DIR1	2	1	I	Direction-control signal 1. Referenced to $V_{CCA}$ .
DIR2	11	10	I	Direction-control signal 2. Referenced to $V_{CCA}$ . Tie to GND to maintain backward compatibility with SN74AVC8T245 device.
GND	12	11	—	Ground
	13	12	—	Ground
$\overline{OE}$	22	21	I	Output Enable. Pull to GND to enable all outputs. Pull to $V_{CCA}$ to place all outputs in high-impedance mode. Referenced to $V_{CCA}$ .
$V_{CCA}$	1	24	—	A-port supply voltage. $0.65V \leq V_{CCA} \leq 3.6V$
$V_{CCB}$	23	22	—	B-port supply voltage. $0.65V \leq V_{CCB} \leq 3.6V$
	24	23	—	B-port supply voltage. $0.65V \leq V_{CCB} \leq 3.6V$

(1) PAD - may be grounded (recommended) or left floating.

## 5 Specifications

### 5.1 Absolute Maximum Ratings

over operating free-air temperature range (unless otherwise noted)<sup>(1)</sup>

		MIN	MAX	UNIT
Supply voltage, $V_{CCA}$		-0.5	4.2	V
Supply voltage, $V_{CCB}$		-0.5	4.2	V
Input voltage, $V_I$ <sup>(2)</sup>	I/O ports (A port)	-0.5	4.2	V
	I/O ports (B port)	-0.5	4.2	
	Control inputs	-0.5	4.2	
Voltage applied to any output in the high-impedance or power-off state, $V_O$ <sup>(2)</sup>	A port	-0.5	4.2	V
	B port	-0.5	4.2	
Voltage applied to any output in the high or low state, $V_O$ <sup>(2) (3)</sup>	A port	-0.5	$V_{CCA} + 0.2$	V
	B port	-0.5	$V_{CCB} + 0.2$	
Input clamp current, $I_{IK}$	$V_I < 0$	-50		mA
Output clamp current, $I_{OK}$	$V_O < 0$	-50		mA
Continuous output current, $I_O$		-50	50	mA
Continuous current through $V_{CCA}$ , $V_{CCB}$ , or GND		-100	100	mA
Junction Temperature, $T_J$			150	°C
Storage temperature, $T_{stg}$		-65	150	°C

- (1) Stresses beyond those listed under *Absolute Maximum Ratings* may cause permanent damage to the device. These are stress ratings only, which do not imply functional operation of the device at these or any other conditions beyond those indicated under *Recommended Operating Conditions*. Exposure to absolute-maximum-rated conditions for extended periods may affect device reliability.
- (2) The input voltage and output negative-voltage ratings may be exceeded if the input and output current ratings are observed.
- (3) The output positive-voltage rating may be exceeded up to 4.2V maximum if the output current rating is observed.

### 5.2 ESD Ratings

		VALUE	UNIT
$V_{(ESD)}$ Electrostatic discharge	Human-body model (HBM), per ANSI/ESDA/JEDEC JS-001 <sup>(1)</sup>	±8000	V
	Charged-device model (CDM), per JEDEC specification JESD22-C101 <sup>(2)</sup>	±1000	

- (1) JEDEC document JEP155 states that 500-V HBM allows safe manufacturing with a standard ESD control process.
- (2) JEDEC document JEP157 states that 250-V CDM allows safe manufacturing with a standard ESD control process.

### 5.3 Recommended Operating Conditions

over operating free-air temperature range (unless otherwise noted) <sup>(1)</sup> <sup>(2)</sup> <sup>(3)</sup>

		MIN	MAX	UNIT	
V <sub>CCA</sub>	Supply voltage	0.65	3.6	V	
V <sub>C CB</sub>	Supply voltage	0.65	3.6	V	
V <sub>IH</sub>	High-level input voltage	Data inputs	V <sub>CCI</sub> = 0.65V - 0.75V	V <sub>CCI</sub> × 0.70	V
			V <sub>CCI</sub> = 0.76V - 1V	V <sub>CCI</sub> × 0.70	
			V <sub>CCI</sub> = 1.1V - 1.95V	V <sub>CCI</sub> × 0.65	
			V <sub>CCI</sub> = 2.3V - 2.7V	1.6	
			V <sub>CCI</sub> = 3V - 3.6V	2	
		Control inputs (DIR, OE) Referenced to V <sub>CCA</sub>	V <sub>CCA</sub> = 0.65V - 0.75V	V <sub>CCA</sub> × 0.70	
			V <sub>CCA</sub> = 0.76V - 1V	V <sub>CCA</sub> × 0.70	
			V <sub>CCA</sub> = 1.1V - 1.95V	V <sub>CCA</sub> × 0.65	
			V <sub>CCA</sub> = 2.3V - 2.7V	1.6	
			V <sub>CCA</sub> = 3V - 3.6V	2	
V <sub>IL</sub>	Low-level input voltage	Data inputs	V <sub>CCI</sub> = 0.65V - 0.75V	V <sub>CCI</sub> × 0.30	V
			V <sub>CCI</sub> = 0.76V - 1V	V <sub>CCI</sub> × 0.30	
			V <sub>CCI</sub> = 1.1V - 1.95V	V <sub>CCI</sub> × 0.35	
			V <sub>CCI</sub> = 2.3V - 2.7V	0.7	
			V <sub>CCI</sub> = 3V - 3.6V	0.8	
		Control inputs (DIR, OE) Referenced to V <sub>CCA</sub>	V <sub>CCA</sub> = 0.65V - 0.75V	V <sub>CCA</sub> × 0.30	
			V <sub>CCA</sub> = 0.76V - 1V	V <sub>CCA</sub> × 0.30	
			V <sub>CCA</sub> = 1.1V - 1.95V	V <sub>CCA</sub> × 0.35	
			V <sub>CCA</sub> = 2.3V - 2.7V	0.7	
			V <sub>CCA</sub> = 3V - 3.6V	0.8	
V <sub>I</sub>	Input voltage <sup>(3)</sup>	0	3.6	V	
V <sub>O</sub>	Output voltage	Active state	0	V <sub>CCO</sub> <sup>(2)</sup>	V
		Tri-state	0	3.6	
Δt/Δv	Input transition rise or fall rate		10	ns/V	
T <sub>A</sub>	Operating free-air temperature	-40	125	°C	

- (1) V<sub>CCI</sub> is the V<sub>CC</sub> associated with the input port.  
(2) V<sub>CCO</sub> is the V<sub>CC</sub> associated with the output port.  
(3) All unused data inputs of the device must be held at V<sub>CCI</sub> or GND for proper device operation. See the [Implications of Slow or Floating CMOS Inputs](#) application report.

### 5.4 Thermal Information

THERMAL METRIC	SN74AXC8T245			UNIT	
	PW (TSSOP)	RHL (VQFN)	RJW (UQFN)		
	24 PINS	24 PINS	24 PINS		
R <sub>θJA</sub>	Junction-to-ambient thermal resistance	92.0	35.0	123.1	°C/W
R <sub>θJC(top)</sub>	Junction-to-case (top) thermal resistance	29.3	39.9	65.0	°C/W
R <sub>θJB</sub>	Junction-to-board thermal resistance	46.7	13.8	55.3	°C/W
ψ <sub>JT</sub>	Junction-to-top characterization parameter	1.5	0.3	3.9	°C/W
ψ <sub>JB</sub>	Junction-to-board characterization parameter	46.2	13.8	54.9	°C/W
R <sub>θJC(bot)</sub>	Junction-to-case (bottom) thermal resistance	N/A	1.4	N/A	°C/W

## 5.5 Electrical Characteristics

Over recommended operating free-air temperature range (unless otherwise noted)<sup>(1)</sup>

PARAMETER	TEST CONDITIONS	V <sub>CCA</sub>	V <sub>CCB</sub>	–40°C to 85°C			–40°C to 125°C			UNIT
				MIN	TYP <sup>(2)</sup>	MAX	MIN	TYP <sup>(2)</sup>	MAX	
V <sub>OH</sub> High-level output voltage	V <sub>I</sub> = V <sub>IH</sub>	I <sub>OH</sub> = –100µA	0.7V - 3.6V	0.7V - 3.6V	V <sub>CCO</sub> – 0.1			V <sub>CCO</sub> – 0.1		
		I <sub>OH</sub> = –50µA	0.65V	0.65V	0.55			0.55		
		I <sub>OH</sub> = –200µA	0.76V	0.76V	0.58			0.58		
		I <sub>OH</sub> = –500µA	0.85V	0.85V	0.65			0.65		
		I <sub>OH</sub> = –3mA	1.1V	1.1V	0.85			0.85		
		I <sub>OH</sub> = –6mA	1.4V	1.4V	1.05			1.05		
		I <sub>OH</sub> = –8mA	1.65V	1.65V	1.2			1.2		
		I <sub>OH</sub> = –9mA	2.3V	2.3V	1.75			1.75		
		I <sub>OH</sub> = –12mA	3V	3V	2.3			2.3		
V <sub>OL</sub> Low-level output voltage	V <sub>I</sub> = V <sub>IL</sub>	I <sub>OL</sub> = 100µA	0.7V - 3.6V	0.7V - 3.6V	0.1			0.1		
		I <sub>OL</sub> = 50µA	0.65V	0.65V	0.1			0.1		
		I <sub>OL</sub> = 200µA	0.76V	0.76V	0.18			0.18		
		I <sub>OL</sub> = 500µA	0.85V	0.85V	0.2			0.2		
		I <sub>OL</sub> = 3mA	1.1V	1.1V	0.25			0.25		
		I <sub>OL</sub> = 6mA	1.4V	1.4V	0.35			0.35		
		I <sub>OL</sub> = 8mA	1.65V	1.65V	0.45			0.45		
		I <sub>OL</sub> = 9mA	2.3V	2.3V	0.55			0.55		
		I <sub>OL</sub> = 12mA	3V	3V	0.7			0.7		
I <sub>I</sub> Input leakage current	Control Inputs (DIR, $\overline{OE}$ ): V <sub>I</sub> = V <sub>CCA</sub> or GND	0.65V - 3.6V	0.65V - 3.6V	–0.5			0.5			
I <sub>off</sub> Partial power down current	A Port: V <sub>I</sub> or V <sub>O</sub> = 0V - 3.6V	0V	0V - 3.6V	–4			4			
	B Port: V <sub>I</sub> or V <sub>O</sub> = 0V - 3.6V	0V - 3.6V	0V	–4			4			
I <sub>oz</sub> High- impedance state output current	A Port: V <sub>O</sub> = V <sub>CCO</sub> or GND, V <sub>I</sub> = V <sub>CCI</sub> or GND, $\overline{OE}$ = V <sub>IH</sub>	3.6V	3.6V	–4			4			
	B Port: V <sub>O</sub> = V <sub>CCO</sub> or GND, V <sub>I</sub> = V <sub>CCI</sub> or GND, $\overline{OE}$ = V <sub>IH</sub>	3.6V	3.6V	–4			4			
I <sub>CCA</sub> V <sub>CCA</sub> supply current	V <sub>I</sub> = V <sub>CCI</sub> or GND, I <sub>O</sub> = 0mA	0.65V - 3.6V	0.65V - 3.6V	19			40			
		0V	3.6V	–2			–12			
		3.6V	0V	12			25			
I <sub>CCB</sub> V <sub>CCB</sub> supply current	V <sub>I</sub> = V <sub>CCI</sub> or GND, I <sub>O</sub> = 0mA	0.65V - 3.6V	0.65V - 3.6V	18			38			
		0V	3.6V	12			25			
		3.6V	0V	–2			–12			
I <sub>CCA</sub> + I <sub>CCB</sub> Combined supply current	V <sub>I</sub> = V <sub>CCI</sub> or GND, I <sub>O</sub> = 0mA	0.65V - 3.6V	0.65V - 3.6V	25			55			
C <sub>i</sub> Input capacitance	Control Inputs (DIR, $\overline{OE}$ ): V <sub>I</sub> = 3.3V or GND	3.3V	3.3V	4.5			4.5			
C <sub>io</sub> Data I/O capacitance	Ports A and B: $\overline{OE}$ = V <sub>CCA</sub> , V <sub>O</sub> = 1.65V DC + 1MHz -16dBm sine wave	3.3V	3.3V	5.7			5.7			

(1) V<sub>CCO</sub> is the V<sub>CC</sub> associated with the output port.

(2) All typical values are for T<sub>A</sub> = 25°C

## 5.6 Switching Characteristics, $V_{CCA} = 0.7V$

See [Figure 6-1](#) and [Figure 6-2](#) for test circuit and loading conditions. See [Figure 6-3](#) and [Figure 6-4](#) for measurement waveforms.

PARAMETER	TEST CONDITIONS		B-PORT SUPPLY VOLTAGE ( $V_{CCB}$ )								UNIT
			$0.7V \pm 0.05V$		$0.8V \pm 0.04V$		$0.9V \pm 0.045V$		$1.2V \pm 0.1V$		
			MIN	MAX	MIN	MAX	MIN	MAX	MIN	MAX	
$t_{pd}$ Propagation delay	From input A to output B	-40°C to 85°C	0.5	172	0.5	114	0.5	82	0.5	49	ns
		-40°C to 125°C	0.5	172	0.5	114	0.5	82	0.5	49	
	From input B to output A	-40°C to 85°C	0.5	172	0.5	153	0.5	126	0.5	88	
		-40°C to 125°C	0.5	172	0.5	153	0.5	126	0.5	88	
$t_{dis}$ Disable time	From input $\overline{OE}$ to output A	-40°C to 85°C	0.5	192	0.5	192	0.5	192	0.5	192	ns
		-40°C to 125°C	0.5	195	0.5	195	0.5	195	0.5	195	
	From input $\overline{OE}$ to output B	-40°C to 85°C	0.5	156	0.5	129	0.5	118	0.5	120	
		-40°C to 125°C	0.5	157	0.5	129	0.5	120	0.5	122	
$t_{en}$ Enable time	From input $\overline{OE}$ to output A	-40°C to 85°C	0.5	237	0.5	237	0.5	237	0.5	237	ns
		-40°C to 125°C	0.5	237	0.5	237	0.5	237	0.5	237	
	From input $\overline{OE}$ to output B	-40°C to 85°C	0.5	223	0.5	145	0.5	106	0.5	74	
		-40°C to 125°C	0.5	223	0.5	145	0.5	106	0.5	74	

## Switching Characteristics, $V_{CCA} = 0.7V$

PARAMETER	TEST CONDITIONS		B-PORT SUPPLY VOLTAGE ( $V_{CCB}$ )								UNIT
			$1.5V \pm 0.1V$		$1.8V \pm 0.15V$		$2.5V \pm 0.2V$		$3.3V \pm 0.3V$		
			MIN	MAX	MIN	MAX	MIN	MAX	MIN	MAX	
$t_{pd}$ Propagation delay	From input A to output B	-40°C to 85°C	0.5	46	0.5	49	0.5	61	0.5	142	ns
		-40°C to 125°C	0.5	46	0.5	49	0.5	61	0.5	142	
	From input B to output A	-40°C to 85°C	0.5	83	0.5	82	0.5	81	0.5	81	
		-40°C to 125°C	0.5	83	0.5	82	0.5	81	0.5	81	
$t_{dis}$ Disable time	From input $\overline{OE}$ to output A	-40°C to 85°C	0.5	192	0.5	192	0.5	192	0.5	192	ns
		-40°C to 125°C	0.5	195	0.5	195	0.5	195	0.5	195	
	From input $\overline{OE}$ to output B	-40°C to 85°C	0.5	69	0.5	66	0.5	67	0.5	150	
		-40°C to 125°C	0.5	70	0.5	67	0.5	67	0.5	150	
$t_{en}$ Enable time	From input $\overline{OE}$ to output A	-40°C to 85°C	0.5	237	0.5	237	0.5	237	0.5	237	ns
		-40°C to 125°C	0.5	237	0.5	237	0.5	237	0.5	237	
	From input $\overline{OE}$ to output B	-40°C to 85°C	0.5	68	0.5	69	0.5	84	0.5	552	
		-40°C to 125°C	0.5	68	0.5	69	0.5	84	0.5	552	

## 5.7 Switching Characteristics, $V_{CCA} = 0.8V$

See Figure 6-1 and Figure 6-2 for test circuit and loading conditions. See Figure 6-3 and Figure 6-4 for measurement waveforms.

PARAMETER	TEST CONDITIONS		B-PORT SUPPLY VOLTAGE ( $V_{CCB}$ )								UNIT
			0.7V ± 0.05V		0.8V ± 0.04V		0.9V ± 0.045V		1.2V ± 0.1V		
			MIN	MAX	MIN	MAX	MIN	MAX	MIN	MAX	
$t_{pd}$ Propagation delay	From input A to output B	-40°C to 85°C	0.5	153	0.5	95	0.5	62	0.5	32	ns
		-40°C to 125°C	0.5	153	0.5	95	0.5	62	0.5	32	
	From input B to output A	-40°C to 85°C	0.5	114	0.5	95	0.5	78	0.5	52	
		-40°C to 125°C	0.5	114	0.5	95	0.5	78	0.5	52	
$t_{dis}$ Disable time	From input $\overline{OE}$ to output A	-40°C to 85°C	0.5	101	0.5	101	0.5	101	0.5	101	ns
		-40°C to 125°C	0.5	103	0.5	103	0.5	103	0.5	103	
	From input $\overline{OE}$ to output B	-40°C to 85°C	0.5	141	0.5	114	0.5	104	0.5	106	
		-40°C to 125°C	0.5	142	0.5	115	0.5	106	0.5	109	
$t_{en}$ Enable time	From input $\overline{OE}$ to output A	-40°C to 85°C	0.5	102	0.5	102	0.5	102	0.5	102	ns
		-40°C to 125°C	0.5	102	0.5	102	0.5	102	0.5	102	
	From input $\overline{OE}$ to output B	-40°C to 85°C	0.5	202	0.5	124	0.5	86	0.5	52	
		-40°C to 125°C	0.5	202	0.5	124	0.5	86	0.5	52	

## Switching Characteristics, $V_{CCA} = 0.8V$

PARAMETER	TEST CONDITIONS		B-PORT SUPPLY VOLTAGE ( $V_{CCB}$ )								UNIT
			1.5V ± 0.1V		1.8V ± 0.15V		2.5V ± 0.2V		3.3V ± 0.3V		
			MIN	MAX	MIN	MAX	MIN	MAX	MIN	MAX	
$t_{pd}$ Propagation delay	From input A to output B	-40°C to 85°C	0.5	26	0.5	25	0.5	25	0.5	35	ns
		-40°C to 125°C	0.5	26	0.5	25	0.5	25	0.5	35	
	From input B to output A	-40°C to 85°C	0.5	42	0.5	41	0.5	40	0.5	40	
		-40°C to 125°C	0.5	42	0.5	41	0.5	40	0.5	40	
$t_{dis}$ Disable time	From input $\overline{OE}$ to output A	-40°C to 85°C	0.5	101	0.5	101	0.5	101	0.5	101	ns
		-40°C to 125°C	0.5	103	0.5	103	0.5	103	0.5	103	
	From input $\overline{OE}$ to output B	-40°C to 85°C	0.5	55	0.5	51	0.5	49	0.5	51	
		-40°C to 125°C	0.5	57	0.5	53	0.5	50	0.5	52	
$t_{en}$ Enable time	From input $\overline{OE}$ to output A	-40°C to 85°C	0.5	102	0.5	102	0.5	102	0.5	102	ns
		-40°C to 125°C	0.5	102	0.5	102	0.5	102	0.5	102	
	From input $\overline{OE}$ to output B	-40°C to 85°C	0.5	44	0.5	43	0.5	45	0.5	58	
		-40°C to 125°C	0.5	44	0.5	43	0.5	45	0.5	58	

### 5.8 Switching Characteristics, $V_{CCA} = 0.9V$

See Figure 6-1 and Figure 6-2 for test circuit and loading conditions. See Figure 6-3 and Figure 6-4 for measurement waveforms.

PARAMETER	TEST CONDITIONS		B-PORT SUPPLY VOLTAGE ( $V_{CCB}$ )								UNIT
			0.7V ± 0.05V		0.8V ± 0.04V		0.9V ± 0.045V		1.2V ± 0.1V		
			MIN	MAX	MIN	MAX	MIN	MAX	MIN	MAX	
$t_{pd}$ Propagation delay	From input A to output B	-40°C to 85°C	0.5	127	0.5	78	0.5	52	0.5	23	ns
		-40°C to 125°C	0.5	127	0.5	78	0.5	52	0.5	23	
	From input B to output A	-40°C to 85°C	0.5	82	0.5	63	0.5	52	0.5	39	
		-40°C to 125°C	0.5	82	0.5	63	0.5	52	0.5	39	
$t_{dis}$ Disable time	From input $\overline{OE}$ to output A	-40°C to 85°C	0.5	125	0.5	125	0.5	125	0.5	125	ns
		-40°C to 125°C	0.5	128	0.5	128	0.5	128	0.5	128	
	From input $\overline{OE}$ to output B	-40°C to 85°C	0.5	131	0.5	105	0.5	96	0.5	99	
		-40°C to 125°C	0.5	133	0.5	107	0.5	98	0.5	101	
$t_{en}$ Enable time	From input $\overline{OE}$ to output A	-40°C to 85°C	0.5	124	0.5	124	0.5	124	0.5	124	ns
		-40°C to 125°C	0.5	128	0.5	128	0.5	128	0.5	128	
	From input $\overline{OE}$ to output B	-40°C to 85°C	0.5	191	0.5	113	0.5	75	0.5	41	
		-40°C to 125°C	0.5	191	0.5	113	0.5	75	0.5	41	

### Switching Characteristics, $V_{CCA} = 0.9V$

PARAMETER	TEST CONDITIONS		B-PORT SUPPLY VOLTAGE ( $V_{CCB}$ )								UNIT
			1.5V ± 0.1V		1.8V ± 0.15V		2.5V ± 0.2V		3.3V ± 0.3V		
			MIN	MAX	MIN	MAX	MIN	MAX	MIN	MAX	
$t_{pd}$ Propagation delay	From input A to output B	-40°C to 85°C	0.5	17	0.5	15	0.5	14	0.5	17	ns
		-40°C to 125°C	0.5	17	0.5	15	0.5	14	0.5	17	
	From input B to output A	-40°C to 85°C	0.5	28	0.5	24	0.5	22	0.5	22	
		-40°C to 125°C	0.5	28	0.5	24	0.5	22	0.5	22	
$t_{dis}$ Disable time	From input $\overline{OE}$ to output A	-40°C to 85°C	0.5	125	0.5	125	0.5	125	0.5	125	ns
		-40°C to 125°C	0.5	128	0.5	128	0.5	128	0.5	128	
	From input $\overline{OE}$ to output B	-40°C to 85°C	0.5	47	0.5	44	0.5	40	0.5	73	
		-40°C to 125°C	0.5	50	0.5	46	0.5	42	0.5	73	
$t_{en}$ Enable time	From input $\overline{OE}$ to output A	-40°C to 85°C	0.5	124	0.5	124	0.5	124	0.5	124	ns
		-40°C to 125°C	0.5	128	0.5	128	0.5	128	0.5	128	
	From input $\overline{OE}$ to output B	-40°C to 85°C	0.5	34	0.5	32	0.5	31	0.5	35	
		-40°C to 125°C	0.5	34	0.5	32	0.5	31	0.5	35	

## 5.9 Switching Characteristics, $V_{CCA} = 1.2V$

See Figure 6-1 and Figure 6-2 for test circuit and loading conditions. See Figure 6-3 and Figure 6-4 for measurement waveforms.

PARAMETER	TEST CONDITIONS		B-PORT SUPPLY VOLTAGE ( $V_{CCB}$ )								UNIT
			$0.7V \pm 0.05V$		$0.8V \pm 0.04V$		$0.9V \pm 0.045V$		$1.2V \pm 0.1V$		
			MIN	MAX	MIN	MAX	MIN	MAX	MIN	MAX	
$t_{pd}$ Propagation delay	From input A to output B	$-40^{\circ}C$ to $85^{\circ}C$	0.5	88	0.5	52	0.5	39	0.5	15	ns
		$-40^{\circ}C$ to $125^{\circ}C$	0.5	88	0.5	52	0.5	39	0.5	15	
	From input B to output A	$-40^{\circ}C$ to $85^{\circ}C$	0.5	49	0.5	32	0.5	23	0.5	15	
		$-40^{\circ}C$ to $125^{\circ}C$	0.5	49	0.5	32	0.5	23	0.5	15	
$t_{dis}$ Disable time	From input $\overline{OE}$ to output A	$-40^{\circ}C$ to $85^{\circ}C$	0.5	87	0.5	87	0.5	87	0.5	87	ns
		$-40^{\circ}C$ to $125^{\circ}C$	0.5	91	0.5	91	0.5	91	0.5	91	
	From input $\overline{OE}$ to output B	$-40^{\circ}C$ to $85^{\circ}C$	0.5	119	0.5	94	0.5	85	0.5	89	
		$-40^{\circ}C$ to $125^{\circ}C$	0.5	121	0.5	96	0.5	88	0.5	93	
$t_{en}$ Enable time	From input $\overline{OE}$ to output A	$-40^{\circ}C$ to $85^{\circ}C$	0.5	34	0.5	34	0.5	34	0.5	34	ns
		$-40^{\circ}C$ to $125^{\circ}C$	0.5	36	0.5	36	0.5	36	0.5	36	
	From input $\overline{OE}$ to output B	$-40^{\circ}C$ to $85^{\circ}C$	0.5	168	0.5	98	0.5	61	0.5	29	
		$-40^{\circ}C$ to $125^{\circ}C$	0.5	168	0.5	98	0.5	61	0.5	30	

## Switching Characteristics, $V_{CCA} = 1.2V$

PARAMETER	TEST CONDITIONS		B-PORT SUPPLY VOLTAGE ( $V_{CCB}$ )								UNIT
			$1.5V \pm 0.1V$		$1.8V \pm 0.15V$		$2.5V \pm 0.2V$		$3.3V \pm 0.3V$		
			MIN	MAX	MIN	MAX	MIN	MAX	MIN	MAX	
$t_{pd}$ Propagation delay	From input A to output B	$-40^{\circ}C$ to $85^{\circ}C$	0.5	10	0.5	9	0.5	7	0.5	7	ns
		$-40^{\circ}C$ to $125^{\circ}C$	0.5	10	0.5	9	0.5	7	0.5	8	
	From input B to output A	$-40^{\circ}C$ to $85^{\circ}C$	0.5	13	0.5	11	0.5	8	0.5	7	
		$-40^{\circ}C$ to $125^{\circ}C$	0.5	13	0.5	11	0.5	8	0.5	7	
$t_{dis}$ Disable time	From input $\overline{OE}$ to output A	$-40^{\circ}C$ to $85^{\circ}C$	0.5	87	0.5	87	0.5	87	0.5	87	ns
		$-40^{\circ}C$ to $125^{\circ}C$	0.5	91	0.5	91	0.5	91	0.5	91	
	From input $\overline{OE}$ to output B	$-40^{\circ}C$ to $85^{\circ}C$	0.5	38	0.5	35	0.5	31	0.5	29	
		$-40^{\circ}C$ to $125^{\circ}C$	0.5	41	0.5	38	0.5	33	0.5	31	
$t_{en}$ Enable time	From input $\overline{OE}$ to output A	$-40^{\circ}C$ to $85^{\circ}C$	0.5	34	0.5	34	0.5	34	0.5	34	ns
		$-40^{\circ}C$ to $125^{\circ}C$	0.5	36	0.5	36	0.5	36	0.5	36	
	From input $\overline{OE}$ to output B	$-40^{\circ}C$ to $85^{\circ}C$	0.5	22	0.5	19	0.5	17	0.5	17	
		$-40^{\circ}C$ to $125^{\circ}C$	0.5	23	0.5	20	0.5	18	0.5	18	

### 5.10 Switching Characteristics, $V_{CCA} = 1.5V$

See Figure 6-1 and Figure 6-2 for test circuit and loading conditions. See Figure 6-3 and Figure 6-4 for measurement waveforms.

PARAMETER	TEST CONDITIONS		B-PORT SUPPLY VOLTAGE ( $V_{CCB}$ )								UNIT
			0.7V ± 0.05V		0.8V ± 0.04V		0.9V ± 0.045V		1.2V ± 0.1V		
			MIN	MAX	MIN	MAX	MIN	MAX	MIN	MAX	
$t_{pd}$ Propagation delay	From input A to output B	-40°C to 85°C	0.5	84	0.5	42	0.5	28	0.5	13	ns
		-40°C to 125°C	0.5	84	0.5	42	0.5	28	0.5	13	
	From input B to output A	-40°C to 85°C	0.5	46	0.5	26	0.5	17	0.5	10	
		-40°C to 125°C	0.5	46	0.5	26	0.5	17	0.5	10	
$t_{dis}$ Disable time	From input $\overline{OE}$ to output A	-40°C to 85°C	0.5	34	0.5	34	0.5	34	0.5	34	ns
		-40°C to 125°C	0.5	37	0.5	37	0.5	37	0.5	37	
	From input $\overline{OE}$ to output B	-40°C to 85°C	0.5	115	0.5	89	0.5	80	0.5	85	
		-40°C to 125°C	0.5	117	0.5	91	0.5	83	0.5	89	
$t_{en}$ Enable time	From input $\overline{OE}$ to output A	-40°C to 85°C	0.5	21	0.5	21	0.5	21	0.5	21	ns
		-40°C to 125°C	0.5	23	0.5	23	0.5	23	0.5	23	
	From input $\overline{OE}$ to output B	-40°C to 85°C	0.5	159	0.5	90	0.5	55	0.5	24	
		-40°C to 125°C	0.5	159	0.5	90	0.5	55	0.5	25	

### Switching Characteristics, $V_{CCA} = 1.5V$

PARAMETER	TEST CONDITIONS		B-PORT SUPPLY VOLTAGE ( $V_{CCB}$ )								UNIT
			1.5V ± 0.1V		1.8V ± 0.15V		2.5V ± 0.2V		3.3V ± 0.3V		
			MIN	MAX	MIN	MAX	MIN	MAX	MIN	MAX	
$t_{pd}$ Propagation delay	From input A to output B	-40°C to 85°C	0.5	9	0.5	7	0.5	6	0.5	5	ns
		-40°C to 125°C	0.5	9	0.5	7	0.5	6	0.5	6	
	From input B to output A	-40°C to 85°C	0.5	9	0.5	7	0.5	6	0.5	5	
		-40°C to 125°C	0.5	9	0.5	8	0.5	6	0.5	5	
$t_{dis}$ Disable time	From input $\overline{OE}$ to output A	-40°C to 85°C	0.5	34	0.5	34	0.5	34	0.5	34	ns
		-40°C to 125°C	0.5	37	0.5	37	0.5	37	0.5	37	
	From input $\overline{OE}$ to output B	-40°C to 85°C	0.5	35	0.5	31	0.5	28	0.5	25	
		-40°C to 125°C	0.5	38	0.5	34	0.5	31	0.5	27	
$t_{en}$ Enable time	From input $\overline{OE}$ to output A	-40°C to 85°C	0.5	21	0.5	21	0.5	21	0.5	21	ns
		-40°C to 125°C	0.5	23	0.5	23	0.5	23	0.5	23	
	From input $\overline{OE}$ to output B	-40°C to 85°C	0.5	17	0.5	15	0.5	12	0.5	11	
		-40°C to 125°C	0.5	18	0.5	15	0.5	13	0.5	12	

### 5.11 Switching Characteristics, $V_{CCA} = 1.8V$

See Figure 6-1 and Figure 6-2 for test circuit and loading conditions. See Figure 6-3 and Figure 6-4 for measurement waveforms.

PARAMETER	TEST CONDITIONS		B-PORT SUPPLY VOLTAGE ( $V_{CCB}$ )								UNIT
			0.7V ± 0.05V		0.8V ± 0.04V		0.9V ± 0.045V		1.2V ± 0.1V		
			MIN	MAX	MIN	MAX	MIN	MAX	MIN	MAX	
$t_{pd}$ Propagation delay	From input A to output B	-40°C to 85°C	0.5	82	0.5	41	0.5	24	0.5	11	ns
		-40°C to 125°C	0.5	82	0.5	41	0.5	24	0.5	11	
	From input B to output A	-40°C to 85°C	0.5	49	0.5	25	0.5	15	0.5	9	
		-40°C to 125°C	0.5	49	0.5	25	0.5	15	0.5	9	
$t_{dis}$ Disable time	From input $\overline{OE}$ to output A	-40°C to 85°C	0.5	37	0.5	37	0.5	37	0.5	37	ns
		-40°C to 125°C	0.5	40	0.5	40	0.5	40	0.5	40	
	From input $\overline{OE}$ to output B	-40°C to 85°C	0.5	113	0.5	87	0.5	78	0.5	83	
		-40°C to 125°C	0.5	115	0.5	89	0.5	81	0.5	87	
$t_{en}$ Enable time	From input $\overline{OE}$ to output A	-40°C to 85°C	0.5	17	0.5	17	0.5	17	0.5	17	ns
		-40°C to 125°C	0.5	19	0.5	19	0.5	19	0.5	19	
	From input $\overline{OE}$ to output B	-40°C to 85°C	0.5	157	0.5	88	0.5	54	0.5	23	
		-40°C to 125°C	0.5	157	0.5	88	0.5	54	0.5	23	

### Switching Characteristics, $V_{CCA} = 1.8V$

PARAMETER	TEST CONDITIONS		B-PORT SUPPLY VOLTAGE ( $V_{CCB}$ )								UNIT
			1.5V ± 0.1V		1.8V ± 0.15V		2.5V ± 0.2V		3.3V ± 0.3V		
			MIN	MAX	MIN	MAX	MIN	MAX	MIN	MAX	
$t_{pd}$ Propagation delay	From input A to output B	-40°C to 85°C	0.5	8	0.5	6	0.5	5	0.5	5	ns
		-40°C to 125°C	0.5	8	0.5	7	0.5	6	0.5	5	
	From input B to output A	-40°C to 85°C	0.5	7	0.5	6	0.5	5	0.5	4	
		-40°C to 125°C	0.5	7	0.5	7	0.5	5	0.5	4	
$t_{dis}$ Disable time	From input $\overline{OE}$ to output A	-40°C to 85°C	0.5	37	0.5	37	0.5	37	0.5	37	ns
		-40°C to 125°C	0.5	40	0.5	40	0.5	40	0.5	40	
	From input $\overline{OE}$ to output B	-40°C to 85°C	0.5	33	0.5	30	0.5	27	0.5	57	
		-40°C to 125°C	0.5	36	0.5	33	0.5	29	0.5	60	
$t_{en}$ Enable time	From input $\overline{OE}$ to output A	-40°C to 85°C	0.5	17	0.5	17	0.5	17	0.5	17	ns
		-40°C to 125°C	0.5	19	0.5	19	0.5	19	0.5	19	
	From input $\overline{OE}$ to output B	-40°C to 85°C	0.5	15	0.5	13	0.5	10	0.5	9	
		-40°C to 125°C	0.5	16	0.5	14	0.5	11	0.5	10	

### 5.12 Switching Characteristics, $V_{CCA} = 2.5V$

See [Figure 6-1](#) and [Figure 6-2](#) for test circuit and loading conditions. See [Figure 6-3](#) and [Figure 6-4](#) for measurement waveforms.

PARAMETER	TEST CONDITIONS		B-PORT SUPPLY VOLTAGE ( $V_{CCB}$ )								UNIT
			0.7V ± 0.05V		0.8V ± 0.04V		0.9V ± 0.045V		1.2V ± 0.1V		
			MIN	MAX	MIN	MAX	MIN	MAX	MIN	MAX	
$t_{pd}$ Propagation delay	From input A to output B	-40°C to 85°C	0.5	81	0.5	40	0.5	22	0.5	8	ns
		-40°C to 125°C	0.5	81	0.5	40	0.5	22	0.5	8	
	From input B to output A	-40°C to 85°C	0.5	61	0.5	25	0.5	14	0.5	7	
		-40°C to 125°C	0.5	61	0.5	25	0.5	14	0.5	7	
$t_{dis}$ Disable time	From input $\overline{OE}$ to output A	-40°C to 85°C	0.5	25	0.5	25	0.5	25	0.5	25	ns
		-40°C to 125°C	0.5	28	0.5	28	0.5	28	0.5	28	
	From input $\overline{OE}$ to output B	-40°C to 85°C	0.5	111	0.5	85	0.5	76	0.5	81	
		-40°C to 125°C	0.5	113	0.5	87	0.5	78	0.5	84	
$t_{en}$ Enable time	From input $\overline{OE}$ to output A	-40°C to 85°C	0.5	11	0.5	11	0.5	11	0.5	11	ns
		-40°C to 125°C	0.5	12	0.5	12	0.5	12	0.5	12	
	From input $\overline{OE}$ to output B	-40°C to 85°C	0.5	155	0.5	86	0.5	52	0.5	21	
		-40°C to 125°C	0.5	155	0.5	86	0.5	52	0.5	21	

### Switching Characteristics, $V_{CCA} = 2.5V$

PARAMETER	TEST CONDITIONS		B-PORT SUPPLY VOLTAGE ( $V_{CCB}$ )								UNIT
			1.5V ± 0.1V		1.8V ± 0.15V		2.5V ± 0.2V		3.3V ± 0.3V		
			MIN	MAX	MIN	MAX	MIN	MAX	MIN	MAX	
$t_{pd}$ Propagation delay	From input A to output B	-40°C to 85°C	0.5	6	0.5	5	0.5	4	0.5	4	ns
		-40°C to 125°C	0.5	6	0.5	5	0.5	5	0.5	4	
	From input B to output A	-40°C to 85°C	0.5	6	0.5	5	0.5	4	0.5	4	
		-40°C to 125°C	0.5	6	0.5	5	0.5	5	0.5	4	
$t_{dis}$ Disable time	From input $\overline{OE}$ to output A	-40°C to 85°C	0.5	25	0.5	25	0.5	25	0.5	25	ns
		-40°C to 125°C	0.5	28	0.5	28	0.5	28	0.5	28	
	From input $\overline{OE}$ to output B	-40°C to 85°C	0.5	31	0.5	28	0.5	25	0.5	23	
		-40°C to 125°C	0.5	34	0.5	31	0.5	28	0.5	25	
$t_{en}$ Enable time	From input $\overline{OE}$ to output A	-40°C to 85°C	0.5	11	0.5	11	0.5	11	0.5	11	ns
		-40°C to 125°C	0.5	12	0.5	12	0.5	12	0.5	12	
	From input $\overline{OE}$ to output B	-40°C to 85°C	0.5	14	0.5	11	0.5	9	0.5	7	
		-40°C to 125°C	0.5	14	0.5	12	0.5	9	0.5	8	

### 5.13 Switching Characteristics, $V_{CCA} = 3.3V$

See Figure 6-1 and Figure 6-2 for test circuit and loading conditions. See Figure 6-3 and Figure 6-4 for measurement waveforms.

PARAMETER	TEST CONDITIONS		B-PORT SUPPLY VOLTAGE ( $V_{CCB}$ )								UNIT
			0.7V ± 0.05V		0.8V ± 0.04V		0.9V ± 0.045V		1.2V ± 0.1V		
			MIN	MAX	MIN	MAX	MIN	MAX	MIN	MAX	
$t_{pd}$ Propagation delay	From input A to output B	-40°C to 85°C	0.5	81	0.5	40	0.5	22	0.5	7	ns
		-40°C to 125°C	0.5	81	0.5	40	0.5	22	0.5	7	
	From input B to output A	-40°C to 85°C	0.5	142	0.5	35	0.5	17	0.5	7	
		-40°C to 125°C	0.5	142	0.5	35	0.5	17	0.5	8	
$t_{dis}$ Disable time	From input $\overline{OE}$ to output A	-40°C to 85°C	0.5	22	0.5	22	0.5	22	0.5	22	ns
		-40°C to 125°C	0.5	24	0.5	24	0.5	24	0.5	24	
	From input $\overline{OE}$ to output B	-40°C to 85°C	0.5	111	0.5	84	0.5	75	0.5	80	
		-40°C to 125°C	0.5	113	0.5	86	0.5	78	0.5	83	
$t_{en}$ Enable time	From input $\overline{OE}$ to output A	-40°C to 85°C	0.5	9	0.5	9	0.5	9	0.5	9	ns
		-40°C to 125°C	0.5	10	0.5	10	0.5	10	0.5	10	
	From input $\overline{OE}$ to output B	-40°C to 85°C	0.5	154	0.5	86	0.5	51	0.5	20	
		-40°C to 125°C	0.5	154	0.5	86	0.5	51	0.5	20	

### Switching Characteristics, $V_{CCA} = 3.3V$

PARAMETER	TEST CONDITIONS		B-PORT SUPPLY VOLTAGE ( $V_{CCB}$ )								UNIT
			1.5V ± 0.1V		1.8V ± 0.15V		2.5V ± 0.2V		3.3V ± 0.3V		
			MIN	MAX	MIN	MAX	MIN	MAX	MIN	MAX	
$t_{pd}$ Propagation delay	From input A to output B	-40°C to 85°C	0.5	5	0.5	4	0.5	4	0.5	4	ns
		-40°C to 125°C	0.5	5	0.5	4	0.5	4	0.5	4	
	From input B to output A	-40°C to 85°C	0.5	5	0.5	5	0.5	4	0.5	4	
		-40°C to 125°C	0.5	6	0.5	5	0.5	4	0.5	4	
$t_{dis}$ Disable time	From input $\overline{OE}$ to output A	-40°C to 85°C	0.5	22	0.5	22	0.5	22	0.5	22	ns
		-40°C to 125°C	0.5	24	0.5	24	0.5	24	0.5	24	
	From input $\overline{OE}$ to output B	-40°C to 85°C	0.5	30	0.5	27	0.5	25	0.5	23	
		-40°C to 125°C	0.5	33	0.5	30	0.5	27	0.5	25	
$t_{en}$ Enable time	From input $\overline{OE}$ to output A	-40°C to 85°C	0.5	9	0.5	9	0.5	9	0.5	9	ns
		-40°C to 125°C	0.5	10	0.5	10	0.5	10	0.5	10	
	From input $\overline{OE}$ to output B	-40°C to 85°C	0.5	13	0.5	10	0.5	8	0.5	7	
		-40°C to 125°C	0.5	14	0.5	11	0.5	8	0.5	7	

**5.14 Operating Characteristics: T<sub>A</sub> = 25°C**

PARAMETER	TEST CONDITIONS	MIN	TYP	MAX	UNIT
C <sub>pdA</sub> Power dissipation capacitance per transceiver (A to B: outputs enabled)	C <sub>L</sub> = 0, R <sub>L</sub> = Open f = 1MHz, t <sub>r</sub> = t <sub>f</sub> = 1 ns	V <sub>CCA</sub> = V <sub>CCB</sub> = 0.7V		1.2	pF
		V <sub>CCA</sub> = V <sub>CCB</sub> = 0.8V		1.8	
		V <sub>CCA</sub> = V <sub>CCB</sub> = 0.9V		1.8	
		V <sub>CCA</sub> = V <sub>CCB</sub> = 1.2V		1.7	
		V <sub>CCA</sub> = V <sub>CCB</sub> = 1.5V		1.7	
		V <sub>CCA</sub> = V <sub>CCB</sub> = 1.8V		1.7	
		V <sub>CCA</sub> = V <sub>CCB</sub> = 2.5V		2	
		V <sub>CCA</sub> = V <sub>CCB</sub> = 3.3V		2.5	
C <sub>pdA</sub> Power dissipation capacitance per transceiver (A to B: outputs disabled)	C <sub>L</sub> = 0, R <sub>L</sub> = Open f = 1MHz, t <sub>r</sub> = t <sub>f</sub> = 1 ns	V <sub>CCA</sub> = V <sub>CCB</sub> = 0.7V		1.1	pF
		V <sub>CCA</sub> = V <sub>CCB</sub> = 0.8V		1.8	
		V <sub>CCA</sub> = V <sub>CCB</sub> = 0.9V		1.8	
		V <sub>CCA</sub> = V <sub>CCB</sub> = 1.2V		1.7	
		V <sub>CCA</sub> = V <sub>CCB</sub> = 1.5V		1.7	
		V <sub>CCA</sub> = V <sub>CCB</sub> = 1.8V		1.7	
		V <sub>CCA</sub> = V <sub>CCB</sub> = 2.5V		2	
		V <sub>CCA</sub> = V <sub>CCB</sub> = 3.3V		2.1	
C <sub>pdA</sub> Power dissipation capacitance per transceiver (B to A: outputs enabled)	C <sub>L</sub> = 0, R <sub>L</sub> = Open f = 1MHz, t <sub>r</sub> = t <sub>f</sub> = 1 ns	V <sub>CCA</sub> = V <sub>CCB</sub> = 0.7V		9.3	pF
		V <sub>CCA</sub> = V <sub>CCB</sub> = 0.8V		11.8	
		V <sub>CCA</sub> = V <sub>CCB</sub> = 0.9V		11.8	
		V <sub>CCA</sub> = V <sub>CCB</sub> = 1.2V		12	
		V <sub>CCA</sub> = V <sub>CCB</sub> = 1.5V		12.2	
		V <sub>CCA</sub> = V <sub>CCB</sub> = 1.8V		13	
		V <sub>CCA</sub> = V <sub>CCB</sub> = 2.5V		16.4	
		V <sub>CCA</sub> = V <sub>CCB</sub> = 3.3V		18.1	
C <sub>pdA</sub> Power dissipation capacitance per transceiver (B to A: outputs disabled)	C <sub>L</sub> = 0, R <sub>L</sub> = Open f = 1MHz, t <sub>r</sub> = t <sub>f</sub> = 1 ns	V <sub>CCA</sub> = V <sub>CCB</sub> = 0.7V		2.6	pF
		V <sub>CCA</sub> = V <sub>CCB</sub> = 0.8V		1.2	
		V <sub>CCA</sub> = V <sub>CCB</sub> = 0.9V		1.1	
		V <sub>CCA</sub> = V <sub>CCB</sub> = 1.2V		1.2	
		V <sub>CCA</sub> = V <sub>CCB</sub> = 1.5V		1.2	
		V <sub>CCA</sub> = V <sub>CCB</sub> = 1.8V		1.3	
		V <sub>CCA</sub> = V <sub>CCB</sub> = 2.5V		1.6	
		V <sub>CCA</sub> = V <sub>CCB</sub> = 3.3V		3.9	

**5.14 Operating Characteristics:  $T_A = 25^\circ\text{C}$  (continued)**

PARAMETER	TEST CONDITIONS	MIN	TYP	MAX	UNIT
$C_{pdB}$ Power dissipation capacitance per transceiver (A to B: outputs enabled)	$C_L = 0$ , $R_L = \text{Open}$ $f = 1\text{MHz}$ , $t_r = t_f = 1\text{ ns}$	$V_{CCA} = V_{CCB} = 0.7\text{V}$		9.3	pF
		$V_{CCA} = V_{CCB} = 0.8\text{V}$		11.7	
		$V_{CCA} = V_{CCB} = 0.9\text{V}$		11.8	
		$V_{CCA} = V_{CCB} = 1.2\text{V}$		11.9	
		$V_{CCA} = V_{CCB} = 1.5\text{V}$		12.2	
		$V_{CCA} = V_{CCB} = 1.8\text{V}$		12.9	
		$V_{CCA} = V_{CCB} = 2.5\text{V}$		16.3	
		$V_{CCA} = V_{CCB} = 3.3\text{V}$		18	
$C_{pdB}$ Power dissipation capacitance per transceiver (A to B: outputs disabled)	$C_L = 0$ , $R_L = \text{Open}$ $f = 1\text{MHz}$ , $t_r = t_f = 1\text{ ns}$	$V_{CCA} = V_{CCB} = 0.7\text{V}$		2.6	pF
		$V_{CCA} = V_{CCB} = 0.8\text{V}$		11.7	
		$V_{CCA} = V_{CCB} = 0.9\text{V}$		11.8	
		$V_{CCA} = V_{CCB} = 1.2\text{V}$		11.9	
		$V_{CCA} = V_{CCB} = 1.5\text{V}$		12.2	
		$V_{CCA} = V_{CCB} = 1.8\text{V}$		12.9	
		$V_{CCA} = V_{CCB} = 2.5\text{V}$		16.3	
		$V_{CCA} = V_{CCB} = 3.3\text{V}$		3.9	
$C_{pdB}$ Power dissipation capacitance per transceiver (B to A: outputs enabled)	$C_L = 0$ , $R_L = \text{Open}$ $f = 1\text{MHz}$ , $t_r = t_f = 1\text{ ns}$	$V_{CCA} = V_{CCB} = 0.7\text{V}$		1.2	pF
		$V_{CCA} = V_{CCB} = 0.8\text{V}$		1.8	
		$V_{CCA} = V_{CCB} = 0.9\text{V}$		1.8	
		$V_{CCA} = V_{CCB} = 1.2\text{V}$		1.7	
		$V_{CCA} = V_{CCB} = 1.5\text{V}$		1.7	
		$V_{CCA} = V_{CCB} = 1.8\text{V}$		1.7	
		$V_{CCA} = V_{CCB} = 2.5\text{V}$		2	
		$V_{CCA} = V_{CCB} = 3.3\text{V}$		2.5	
$C_{pdB}$ Power dissipation capacitance per transceiver (B to A: outputs disabled)	$C_L = 0$ , $R_L = \text{Open}$ $f = 1\text{MHz}$ , $t_r = t_f = 1\text{ ns}$	$V_{CCA} = V_{CCB} = 0.7\text{V}$		1.1	pF
		$V_{CCA} = V_{CCB} = 0.8\text{V}$		1.8	
		$V_{CCA} = V_{CCB} = 0.9\text{V}$		1.8	
		$V_{CCA} = V_{CCB} = 1.2\text{V}$		1.7	
		$V_{CCA} = V_{CCB} = 1.5\text{V}$		1.7	
		$V_{CCA} = V_{CCB} = 1.8\text{V}$		1.7	
		$V_{CCA} = V_{CCB} = 2.5\text{V}$		2	
		$V_{CCA} = V_{CCB} = 3.3\text{V}$		2.1	

## 6 Parameter Measurement Information

Unless otherwise noted, all input pulses are supplied by generators having the following characteristics:

- $f = 1\text{MHz}$
- $Z_0 = 50\ \Omega$
- $dv / dt \leq 1\ \text{ns/V}$

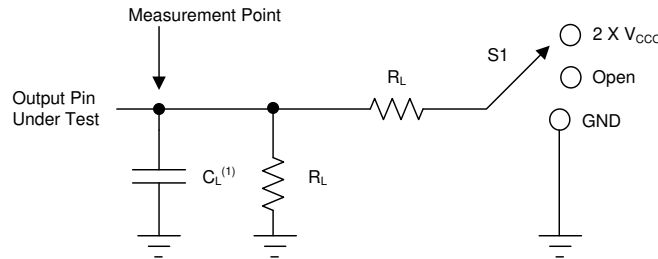

- A.  $C_L$  includes probe and jig capacitance.

Figure 6-1. Load Circuit

Parameter	$V_{CCO}$	$R_L$	$C_L$	S1	$V_{TP}$
$t_{pd}$	1.1 V - 3.6 V	2 k $\Omega$	15 pF	Open	N/A
	0.65 V - 0.95 V	20 k $\Omega$	15 pF	Open	N/A
$t_{en}^{(1)}, t_{dis}^{(1)}$	3 V - 3.6 V	2 k $\Omega$	15 pF	2 X $V_{CCO}$	0.3 V
	1.65 V - 2.7 V	2 k $\Omega$	15 pF	2 X $V_{CCO}$	0.15 V
	1.1 V - 1.6 V	2 k $\Omega$	15 pF	2 X $V_{CCO}$	0.1 V
	0.65 V - 0.95 V	20 k $\Omega$	15 pF	2 X $V_{CCO}$	0.1 V
$t_{en}^{(2)}, t_{dis}^{(2)}$	3 V - 3.6 V	2 k $\Omega$	15 pF	GND	0.3 V
	1.65 V - 2.7 V	2 k $\Omega$	15 pF	GND	0.15 V
	1.1 V - 1.6 V	2 k $\Omega$	15 pF	GND	0.1 V
	0.65 V - 0.95 V	20 k $\Omega$	15 pF	GND	0.1 V

- A. Output waveform on the conditions that input is driven to a valid Logic Low.  
 B. Output waveform on the condition that input is driven to a valid Logic High.

Figure 6-2. Load Circuit Conditions

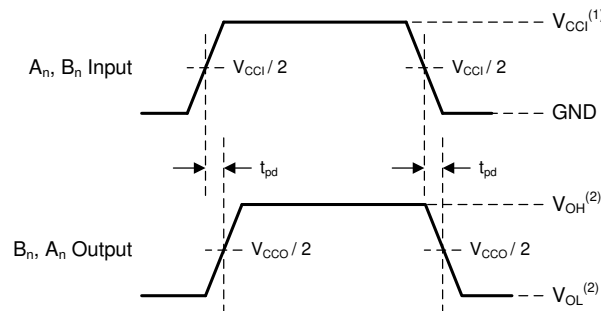

- A.  $V_{CC1}$  is the supply pin associated with the input port.  
 B.  $V_{OH}$  and  $V_{OL}$  are typical output voltage levels with specified  $R_L$ ,  $C_L$ , and  $S_1$ .

Figure 6-3. Propagation Delay

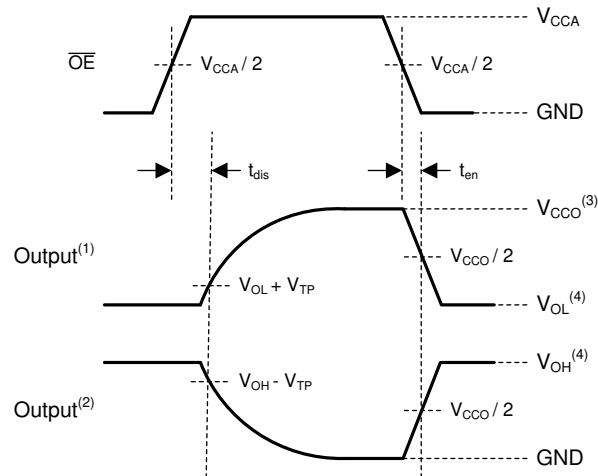

- A. Output waveform on the condition that input is driven to a valid Logic Low.
- B. Output waveform on the condition that input is driven to a valid Logic High.
- C.  $V_{CCO}$  is the supply pin associated with the output port.
- D.  $V_{OH}$  and  $V_{OL}$  are typical output voltage levels with specified  $R_L$ ,  $C_L$ , and  $S_1$ .

**Figure 6-4. Enable Time And Disable Time**

## 7 Detailed Description

### 7.1 Overview

The SN74AXC8T245 device is an 8-bit, dual-supply non-inverting transceiver with bidirectional voltage level translation. The I/O pins labeled with A and the control pins (DIR1, DIR2, and  $\overline{OE}$ ) are supported by  $V_{CCA}$ , and the I/O pins labeled with B are supported by  $V_{CCB}$ . The A port and the B port are able to accept I/O voltages ranging from 0.65V to 3.6V.

### 7.2 Functional Block Diagram

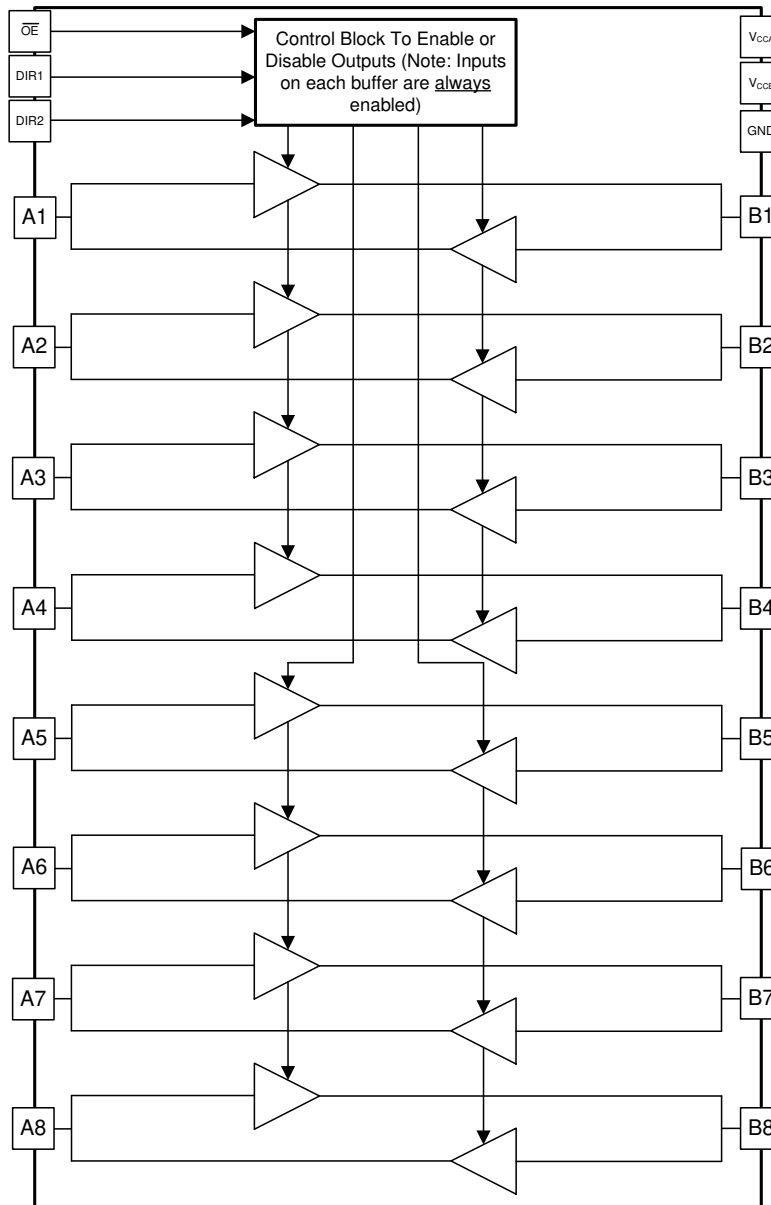

## 7.3 Feature Description

### 7.3.1 Up-Translation and Down-Translation From 0.65V to 3.6V

Both supply pins are configured from 0.65V to 3.6V, which makes the device suitable for translating between any of the low voltage nodes (0.7V, 0.8V, 0.9V, 1.2V, 1.8V, 2.5V, and 3.3V).

### 7.3.2 Multiple Direction Control Pins

Two control pins are used to configure the 8 data I/Os. I/O channels 1 through 4 are grouped together and I/O channels 5 through 8 are banked together. The benefit of this is to permit simultaneous up-translation and down-translation within one device. This eliminates the need for multiple devices, where each device can only provide up-translation or down-translation sequentially. Simultaneous up and down translation is supported when both  $V_{CCA}$  and  $V_{CCB}$  are at least 1.40V.

### 7.3.3 $I_{off}$ Supports Partial-Power-Down Mode Operation

This feature is to limit the leakage current of an I/O pin being driven to a voltage as large as 3.6V while having its corresponding power supply rail powered down. This is represented by the  $I_{off}$  parameter in the [Electrical Characteristics](#) table.

### 7.3.4 I/Os with Integrated Static Pull-Down Resistors

To help avoid floating inputs on the I/Os, this device has 288k $\Omega$  typical integrated weak pull-downs on all data I/Os. This feature allows all inputs to be left floating without the concern for unstable outputs or increased current consumption. This also helps to reduce external component count for applications where not all channels are used or need to be fixed low. If an external pull-up is required, it should be no larger than 30k $\Omega$  to avoid contention with the 288k $\Omega$  internal pull-down.

## 7.4 Device Functional Modes

All control inputs are referenced to  $V_{CCA}$  and must be driven to a valid Logic High or Logic Low (that is, not floating) to assure proper device operation and to prevent excessive power consumption. [Table 7-1](#) summarizes the possible modes of device operation based on the configuration of the control inputs.

**Table 7-1. Function Table**

CONTROL INPUTS <sup>(1)</sup>			Signal Direction	
$\overline{OE}$	DIR1	DIR2	Bits 1:4	Bits 5:8
H	X	X	Disabled (Hi-Z)	
L	L	L	B to A	
L	L	H	B to A	A to B
L	H	L	A to B	
L	H	H	A to B	B to A

(1) Input circuits of the data I/Os are always active and must be driven to a valid logic level.

## 8 Application and Implementation

### Note

Information in the following applications sections is not part of the TI component specification, and TI does not warrant its accuracy or completeness. TI's customers are responsible for determining suitability of components for their purposes, as well as validating and testing their design implementation to confirm system functionality.

### 8.1 Application Information

The SN74AXC8T245 device can be used in level-translation applications for interfacing devices or systems operating at different voltage nodes. [Figure 9-1](#) depicts an application in which the SN74AXC8T245 device is up-translating a 0.7V input to a 3.3V output to interface between a system controller and a peripheral device.

### 8.2 Typical Application

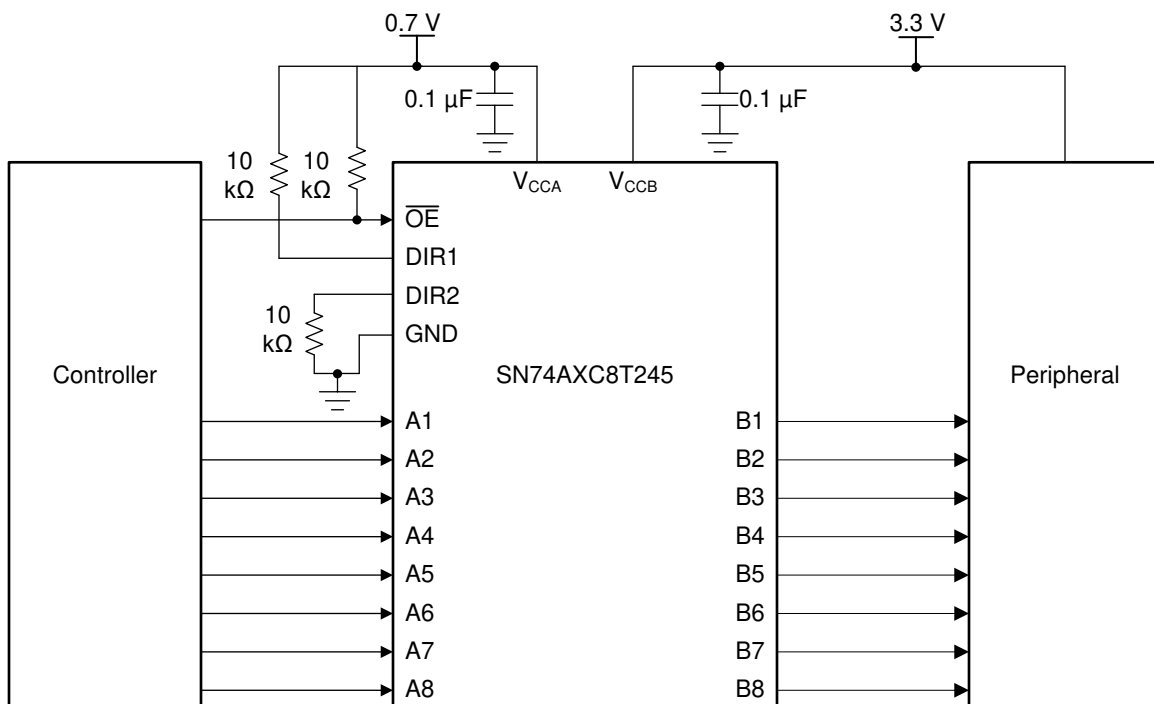

**Figure 8-1. Typical Application Schematic**

### 8.2.1 Design Requirements

For this design example, use the parameters listed in [Table 8-1](#).

**Table 8-1. Design Parameters**

DESIGN PARAMETERS	EXAMPLE VALUE
Input voltage range	0.65V to 3.6V
Output voltage range	0.65V to 3.6V

### 8.2.2 Detailed Design Procedure

To begin the design process, determine the following:

- Input voltage range
  - Use the supply voltage of the device that is driving the SN74AXC8T245 device to determine the input voltage range. For a valid logic high the value must exceed the  $V_{IH}$  of the input port. For a valid logic low the value must be less than the  $V_{IL}$  of the input port.
- Output voltage range
  - Use the supply voltage of the device that the SN74AXC8T245 device is driving to determine the output voltage range.

### 8.2.3 Application Curve

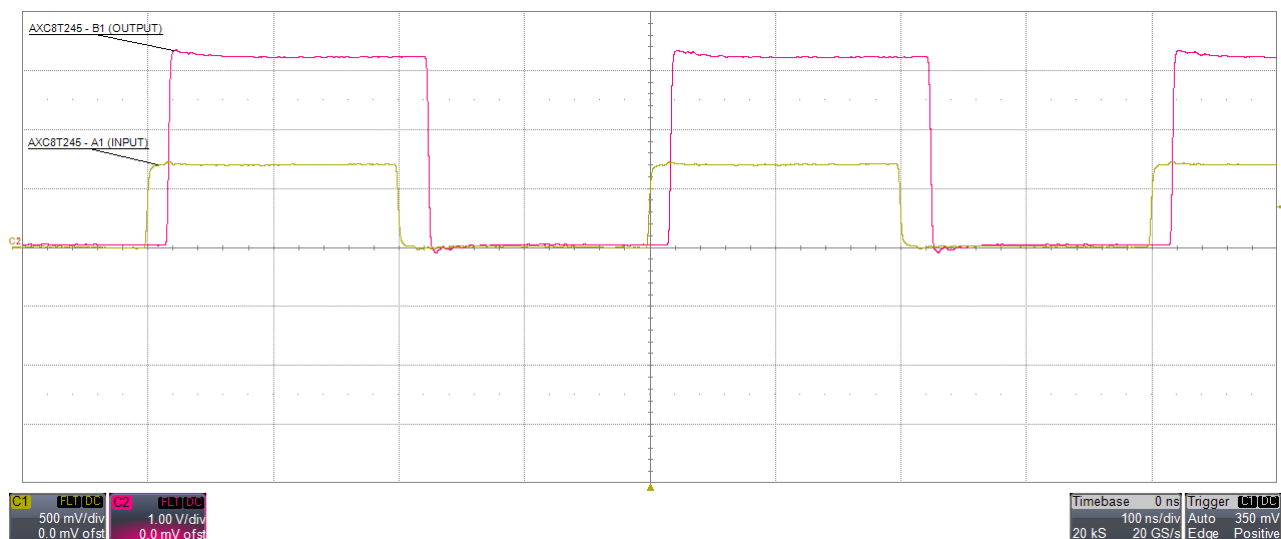

**Figure 8-2. Translation Up (0.7V to 3.3V) at 2.5MHz**

### 8.3 Power Supply Recommendations

Always apply a ground reference to the GND pins first. There are no additional requirements for power supply sequencing.

This device was designed with various power supply sequencing methods in mind to help prevent unintended triggering of downstream devices. For more information regarding the power up glitch performance of the AXC family of level translators, see the [Power Sequencing for AXC Family of Devices](#) application report.

### 8.4 Layout

#### 8.4.1 Layout Guidelines

For device reliability, follow common printed-circuit board layout guidelines.

- Use bypass capacitors on power supplies.
- Use short trace lengths to avoid excessive loading.
- Place pads on the signal paths for loading capacitors or pullup resistors to help adjust rise and fall times of signals depending on the system requirements.

#### 8.4.2 Layout Example

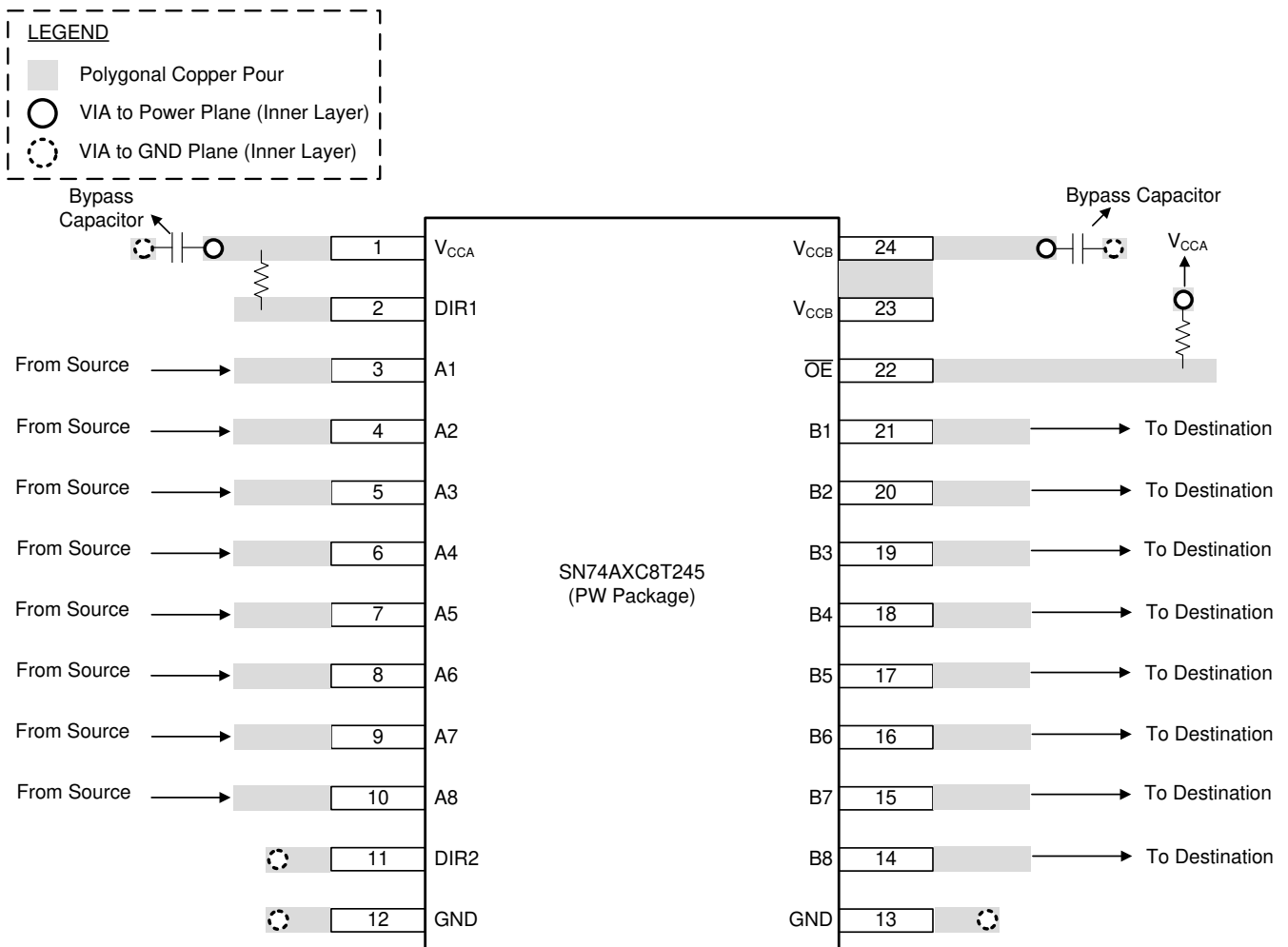

**Figure 8-3. SN74AXC8T245 Device Layout Example**

## 9 Device and Documentation Support

### 9.1 Documentation Support

#### 9.1.1 Related Documentation

For related documentation, see the following:

- Texas Instruments, [SN74AXC8245-Q1 Evaluation Module user's guide](#)
- Texas Instruments, [Implications of Slow or Floating CMOS Inputs application report](#)
- Texas Instruments, [Power Sequencing for AXC Family of Devices application report](#)

#### 9.2 Receiving Notification of Documentation Updates

To receive notification of documentation updates, navigate to the device product folder on [ti.com](http://ti.com). Click on *Notifications* to register and receive a weekly digest of any product information that has changed. For change details, review the revision history included in any revised document.

#### 9.3 Support Resources

[TI E2E™ support forums](#) are an engineer's go-to source for fast, verified answers and design help — straight from the experts. Search existing answers or ask your own question to get the quick design help you need.

Linked content is provided "AS IS" by the respective contributors. They do not constitute TI specifications and do not necessarily reflect TI's views; see TI's [Terms of Use](#).

#### 9.4 Trademarks

TI E2E™ is a trademark of Texas Instruments.  
All trademarks are the property of their respective owners.

#### 9.5 Electrostatic Discharge Caution



This integrated circuit can be damaged by ESD. Texas Instruments recommends that all integrated circuits be handled with appropriate precautions. Failure to observe proper handling and installation procedures can cause damage.

ESD damage can range from subtle performance degradation to complete device failure. Precision integrated circuits may be more susceptible to damage because very small parametric changes could cause the device not to meet its published specifications.

#### 9.6 Glossary

[TI Glossary](#) This glossary lists and explains terms, acronyms, and definitions.

## 10 Revision History

NOTE: Page numbers for previous revisions may differ from page numbers in the current version.

<b>Changes from Revision B (August 2018) to Revision C (January 2024)</b>	<b>Page</b>
• Updated the numbering format for tables, figures, and cross-references throughout the document.....	<a href="#">2</a>
• Added the <i>I<sub>off</sub> Supports Partial-Power-Down Mode Operation</i> section.....	<a href="#">20</a>

<b>Changes from Revision A (July 2018) to Revision B (August 2018)</b>	<b>Page</b>
• Changed data sheet status from Mixed Production to Production Data .....	<a href="#">1</a>
• Removed package preview note from RJW package .....	<a href="#">1</a>

## 11 Mechanical, Packaging, and Orderable Information

The following pages include mechanical, packaging, and orderable information. This information is the most current data available for the designated devices. This data is subject to change without notice and revision of this document. For browser-based versions of this data sheet, refer to the left-hand navigation.

**PACKAGING INFORMATION**

Orderable part number	Status (1)	Material type (2)	Package   Pins	Package qty   Carrier	RoHS (3)	Lead finish/ Ball material (4)	MSL rating/ Peak reflow (5)	Op temp (°C)	Part marking (6)
<a href="#">SN74AXC8T245PWR</a>	Active	Production	TSSOP (PW)   24	2000   LARGE T&R	Yes	NIPDAU	Level-1-260C-UNLIM	-40 to 125	AX8T245
SN74AXC8T245PWR.B	Active	Production	TSSOP (PW)   24	2000   LARGE T&R	Yes	NIPDAU	Level-1-260C-UNLIM	-40 to 125	AX8T245
SN74AXC8T245PWRG4	Active	Production	TSSOP (PW)   24	2000   LARGE T&R	Yes	NIPDAU	Level-1-260C-UNLIM	-40 to 125	AX8T245
SN74AXC8T245PWRG4.B	Active	Production	TSSOP (PW)   24	2000   LARGE T&R	Yes	NIPDAU	Level-1-260C-UNLIM	-40 to 125	AX8T245
<a href="#">SN74AXC8T245RHLR</a>	Active	Production	VQFN (RHL)   24	3000   LARGE T&R	Yes	NIPDAU   SN	Level-1-260C-UNLIM	-40 to 125	AX8T245
SN74AXC8T245RHLR.B	Active	Production	VQFN (RHL)   24	3000   LARGE T&R	Yes	NIPDAU	Level-1-260C-UNLIM	-40 to 125	AX8T245
SN74AXC8T245RHRLG4	Active	Production	VQFN (RHL)   24	3000   LARGE T&R	Yes	NIPDAU	Level-1-260C-UNLIM	-40 to 125	AX8T245
SN74AXC8T245RHRLG4.B	Active	Production	VQFN (RHL)   24	3000   LARGE T&R	Yes	NIPDAU	Level-1-260C-UNLIM	-40 to 125	AX8T245
<a href="#">SN74AXC8T245RJWR</a>	Active	Production	UQFN (RJW)   24	3000   LARGE T&R	Yes	NIPDAUAG	Level-1-260C-UNLIM	-40 to 125	AX8T245
SN74AXC8T245RJWR.B	Active	Production	UQFN (RJW)   24	3000   LARGE T&R	Yes	NIPDAUAG	Level-1-260C-UNLIM	-40 to 125	AX8T245

(1) **Status:** For more details on status, see our [product life cycle](#).

(2) **Material type:** When designated, preproduction parts are prototypes/experimental devices, and are not yet approved or released for full production. Testing and final process, including without limitation quality assurance, reliability performance testing, and/or process qualification, may not yet be complete, and this item is subject to further changes or possible discontinuation. If available for ordering, purchases will be subject to an additional waiver at checkout, and are intended for early internal evaluation purposes only. These items are sold without warranties of any kind.

(3) **RoHS values:** Yes, No, RoHS Exempt. See the [TI RoHS Statement](#) for additional information and value definition.

(4) **Lead finish/Ball material:** Parts may have multiple material finish options. Finish options are separated by a vertical ruled line. Lead finish/Ball material values may wrap to two lines if the finish value exceeds the maximum column width.

(5) **MSL rating/Peak reflow:** The moisture sensitivity level ratings and peak solder (reflow) temperatures. In the event that a part has multiple moisture sensitivity ratings, only the lowest level per JEDEC standards is shown. Refer to the shipping label for the actual reflow temperature that will be used to mount the part to the printed circuit board.

(6) **Part marking:** There may be an additional marking, which relates to the logo, the lot trace code information, or the environmental category of the part.

Multiple part markings will be inside parentheses. Only one part marking contained in parentheses and separated by a "~" will appear on a part. If a line is indented then it is a continuation of the previous line and the two combined represent the entire part marking for that device.

**Important Information and Disclaimer:** The information provided on this page represents TI's knowledge and belief as of the date that it is provided. TI bases its knowledge and belief on information provided by third parties, and makes no representation or warranty as to the accuracy of such information. Efforts are underway to better integrate information from third parties. TI has taken and continues to take reasonable steps to provide representative

and accurate information but may not have conducted destructive testing or chemical analysis on incoming materials and chemicals. TI and TI suppliers consider certain information to be proprietary, and thus CAS numbers and other limited information may not be available for release.

In no event shall TI's liability arising out of such information exceed the total purchase price of the TI part(s) at issue in this document sold by TI to Customer on an annual basis.

**OTHER QUALIFIED VERSIONS OF SN74AXC8T245 :**

- Automotive : [SN74AXC8T245-Q1](#)

NOTE: Qualified Version Definitions:

- Automotive - Q100 devices qualified for high-reliability automotive applications targeting zero defects

**TAPE AND REEL INFORMATION**

**QUADRANT ASSIGNMENTS FOR PIN 1 ORIENTATION IN TAPE**

\*All dimensions are nominal

Device	Package Type	Package Drawing	Pins	SPQ	Reel Diameter (mm)	Reel Width W1 (mm)	A0 (mm)	B0 (mm)	K0 (mm)	P1 (mm)	W (mm)	Pin1 Quadrant
SN74AXC8T245PWR	TSSOP	PW	24	2000	330.0	16.4	6.95	8.3	1.6	8.0	16.0	Q1
SN74AXC8T245PW RG4	TSSOP	PW	24	2000	330.0	16.4	6.95	8.3	1.6	8.0	16.0	Q1
SN74AXC8T245RH LR	VQFN	RHL	24	3000	330.0	12.4	3.8	5.8	1.2	8.0	12.0	Q1
SN74AXC8T245RH LR	VQFN	RHL	24	3000	330.0	12.4	3.8	5.8	1.2	8.0	12.0	Q1
SN74AXC8T245RH LR G4	VQFN	RHL	24	3000	330.0	12.4	3.8	5.8	1.2	8.0	12.0	Q1
SN74AXC8T245R JW R	UQFN	RJW	24	3000	177.8	12.4	2.21	4.22	0.81	4.0	12.0	Q1

**TAPE AND REEL BOX DIMENSIONS**

\*All dimensions are nominal

Device	Package Type	Package Drawing	Pins	SPQ	Length (mm)	Width (mm)	Height (mm)
SN74AXC8T245PWR	TSSOP	PW	24	2000	353.0	353.0	32.0
SN74AXC8T245PWRG4	TSSOP	PW	24	2000	353.0	353.0	32.0
SN74AXC8T245RHLR	VQFN	RHL	24	3000	356.0	356.0	36.0
SN74AXC8T245RHLR	VQFN	RHL	24	3000	367.0	367.0	35.0
SN74AXC8T245RHRLRG4	VQFN	RHL	24	3000	367.0	367.0	35.0
SN74AXC8T245RJWR	UQFN	RJW	24	3000	183.0	183.0	20.0



# EXAMPLE BOARD LAYOUT

PW0024A

TSSOP - 1.2 mm max height

SMALL OUTLINE PACKAGE



LAND PATTERN EXAMPLE  
EXPOSED METAL SHOWN  
SCALE: 10X



SOLDER MASK DETAILS

4220208/A 02/2017

NOTES: (continued)

6. Publication IPC-7351 may have alternate designs.
7. Solder mask tolerances between and around signal pads can vary based on board fabrication site.

# EXAMPLE STENCIL DESIGN

PW0024A

TSSOP - 1.2 mm max height

SMALL OUTLINE PACKAGE



NOTES: (continued)

8. Laser cutting apertures with trapezoidal walls and rounded corners may offer better paste release. IPC-7525 may have alternate design recommendations.
9. Board assembly site may have different recommendations for stencil design.

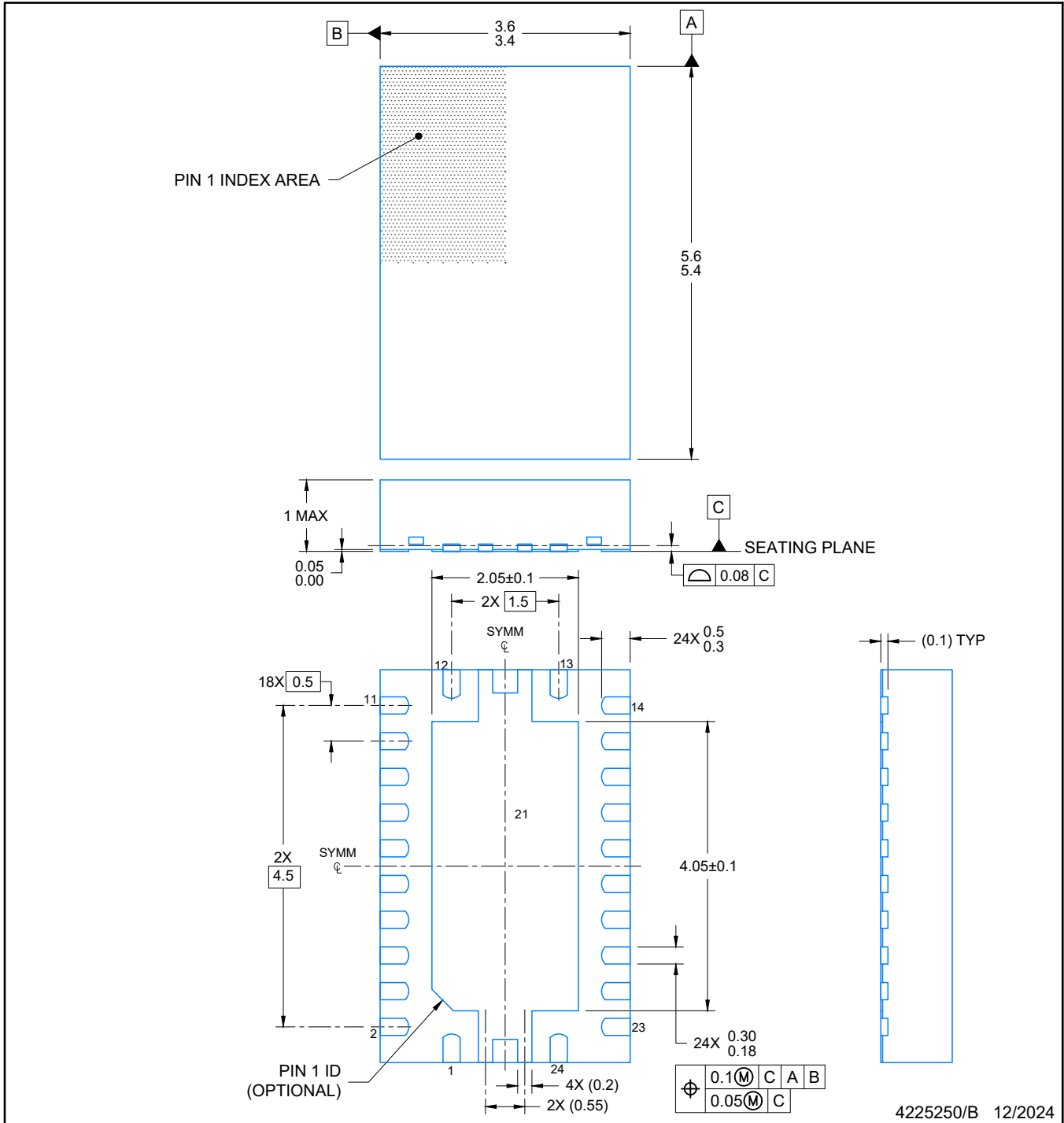

NOTES:

1. All linear dimensions are in millimeters. Any dimensions in parenthesis are for reference only. Dimensioning and tolerancing per ASME Y14.5M.
2. This drawing is subject to change without notice.
3. The package thermal pad must be soldered to the printed circuit board for optimal thermal and mechanical performance.



# EXAMPLE STENCIL DESIGN

VQFN - 1 mm max height

RHL0024A

PLASTIC QUAD FLATPACK- NO LEAD

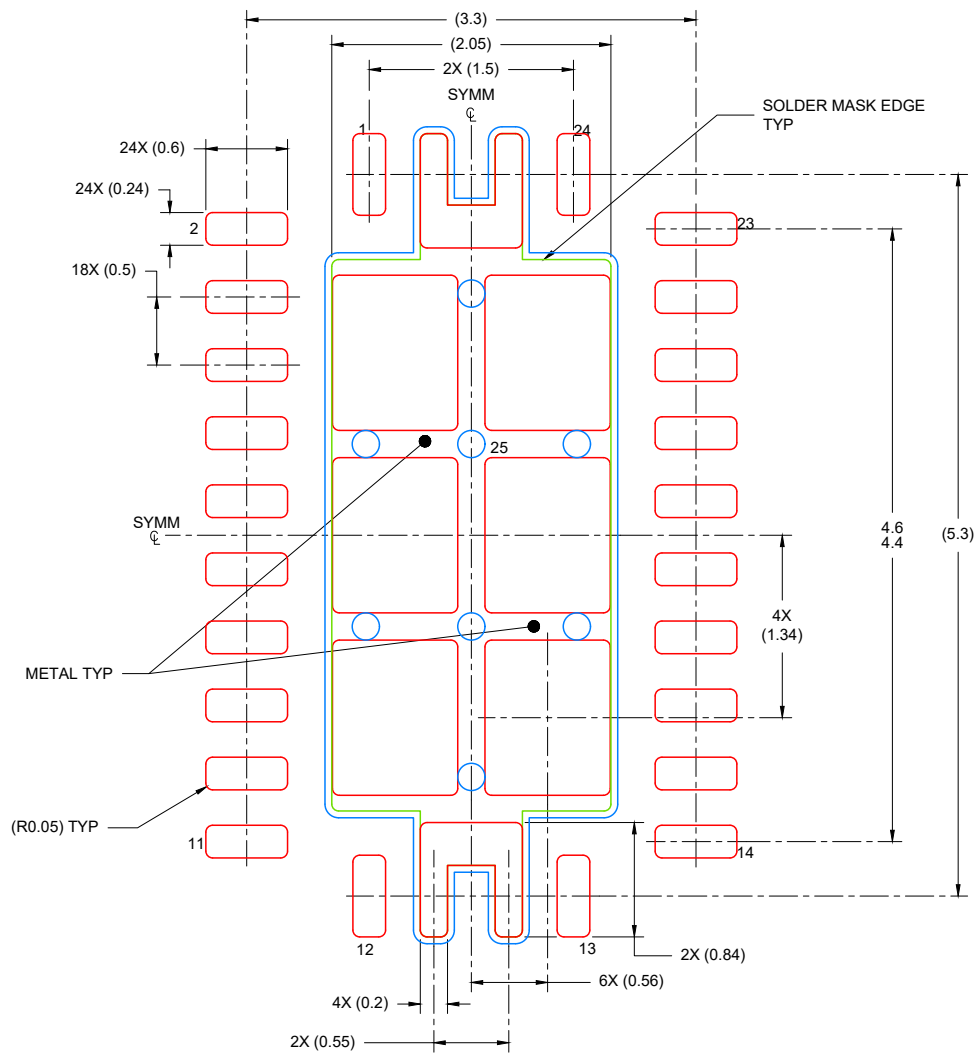

SOLDER PASTE EXAMPLE  
BASED ON 0.125 mm THICK STENCIL

EXPOSED PAD  
80% PRINTED COVERAGE BY AREA  
SCALE: 18X

4225250/B 12/2024

NOTES: (continued)

6. Laser cutting apertures with trapezoidal walls and rounded corners may offer better paste release. IPC-7525 may have alternate design recommendations.

## GENERIC PACKAGE VIEW

**RJW 24**

**UQFN - 0.55 mm max height**

2 x 4, 0.4 mm pitch

PLASTIC QUAD FLATPACK - NO LEAD

This image is a representation of the package family, actual package may vary.  
Refer to the product data sheet for package details.

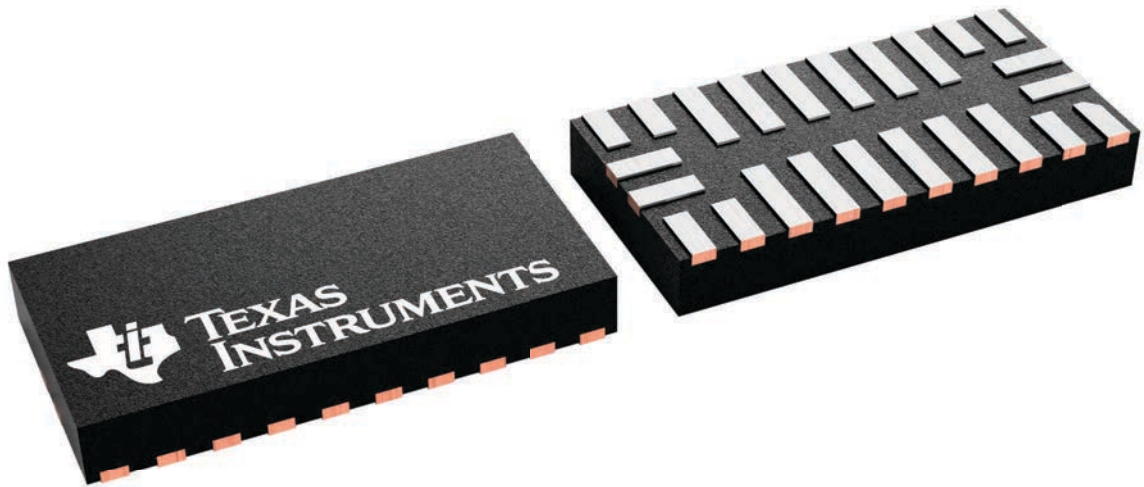

4228367/A



# EXAMPLE BOARD LAYOUT

RJW0024A

UQFN - 0.55 mm max height

PLASTIC QUAD FLATPACK - NO LEAD

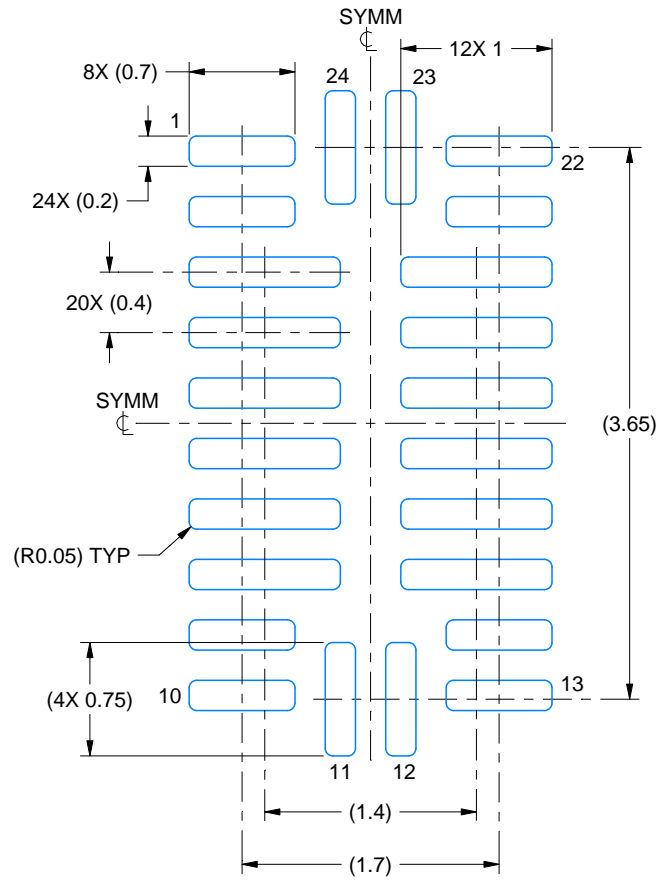

LAND PATTERN EXAMPLE  
EXPOSED METAL SHOWN  
SCALE:20X

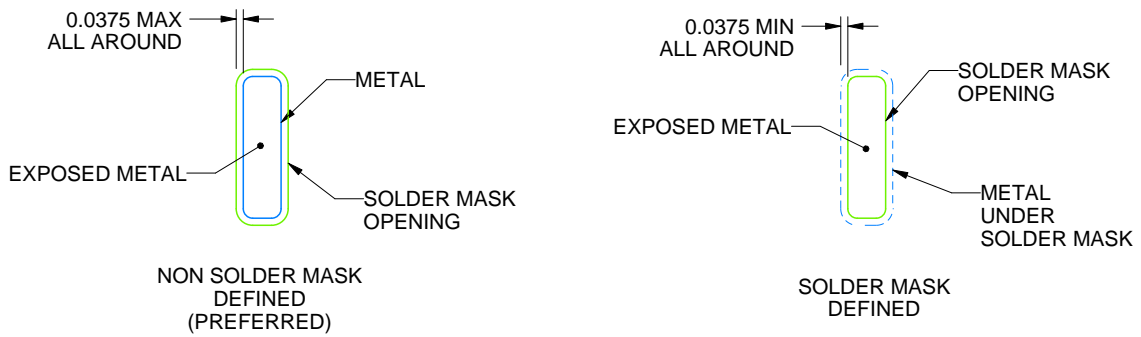

SOLDER MASK DETAILS  
NOT TO SCALE

4223932/B 04/2018

NOTES: (continued)

3. For more information, see Texas Instruments literature number SLUA271 ([www.ti.com/lit/slua271](http://www.ti.com/lit/slua271)).

# EXAMPLE STENCIL DESIGN

RJW0024A

UQFN - 0.55 mm max height

PLASTIC QUAD FLATPACK - NO LEAD

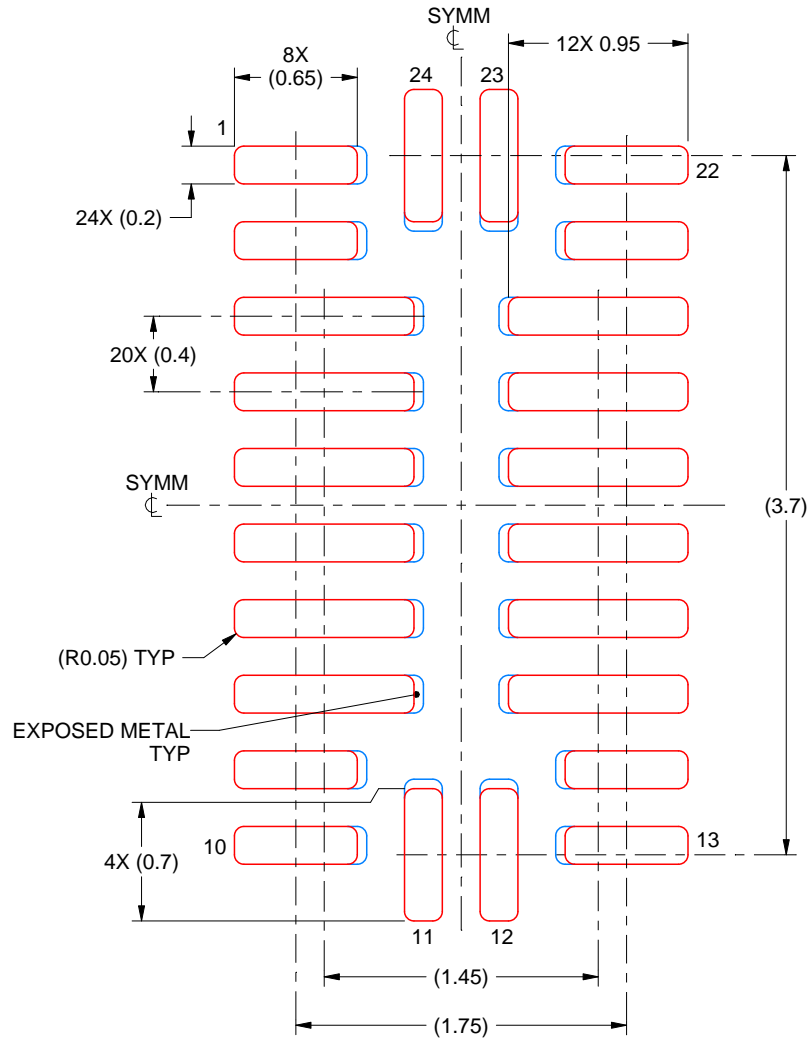

SOLDER PASTE EXAMPLE  
BASED ON 0.1 mm THICKNESS  
SCALE: 25X

4223932/B 04/2018

NOTES: (continued)

4. Laser cutting apertures with trapezoidal walls and rounded corners may offer better paste release. IPC-7525 may have alternate design recommendations.

## IMPORTANT NOTICE AND DISCLAIMER

TI PROVIDES TECHNICAL AND RELIABILITY DATA (INCLUDING DATASHEETS), DESIGN RESOURCES (INCLUDING REFERENCE DESIGNS), APPLICATION OR OTHER DESIGN ADVICE, WEB TOOLS, SAFETY INFORMATION, AND OTHER RESOURCES "AS IS" AND WITH ALL FAULTS, AND DISCLAIMS ALL WARRANTIES, EXPRESS AND IMPLIED, INCLUDING WITHOUT LIMITATION ANY IMPLIED WARRANTIES OF MERCHANTABILITY, FITNESS FOR A PARTICULAR PURPOSE OR NON-INFRINGEMENT OF THIRD PARTY INTELLECTUAL PROPERTY RIGHTS.

These resources are intended for skilled developers designing with TI products. You are solely responsible for (1) selecting the appropriate TI products for your application, (2) designing, validating and testing your application, and (3) ensuring your application meets applicable standards, and any other safety, security, regulatory or other requirements.

These resources are subject to change without notice. TI grants you permission to use these resources only for development of an application that uses the TI products described in the resource. Other reproduction and display of these resources is prohibited. No license is granted to any other TI intellectual property right or to any third party intellectual property right. TI disclaims responsibility for, and you fully indemnify TI and its representatives against any claims, damages, costs, losses, and liabilities arising out of your use of these resources.

TI's products are provided subject to [TI's Terms of Sale](#), [TI's General Quality Guidelines](#), or other applicable terms available either on [ti.com](http://ti.com) or provided in conjunction with such TI products. TI's provision of these resources does not expand or otherwise alter TI's applicable warranties or warranty disclaimers for TI products. Unless TI explicitly designates a product as custom or customer-specified, TI products are standard, catalog, general purpose devices.

TI objects to and rejects any additional or different terms you may propose.

Copyright © 2026, Texas Instruments Incorporated

Last updated 10/2025