

SNx4HCT244 Octal Buffers and Line Drivers With 3-State Outputs

1 Features

- Operating voltage range of 4.5V to 5.5V
- High-current outputs drive up to 15 LSTTL loads
- Low power consumption: 80µA maximum I_{CC}
- Typical $t_{pd} = 13\text{ns}$
- $\pm 6\text{mA}$ output drive at 5V
- Low input current of 1µA maximum
- Inputs are TTL-voltage compatible
- 3-state outputs drive bus lines and buffer memory address registers

2 Applications

- [Servers](#)
- [LED displays](#)
- [Network switches](#)
- [Telecom infrastructure](#)
- [Motor drivers](#)
- [I/O expanders](#)

3 Description

These octal buffers and line drivers are designed specifically to improve both the performance and density of 3-state memory address drivers, clock drivers, and bus-oriented receivers and transmitters. The SNx4HCT244 devices are organized as two 4-bit buffers or drivers with separate output-enable (\overline{OE}) inputs. When \overline{OE} is low, the device passes non inverted data from the A inputs to the Y outputs. When \overline{OE} is high, the outputs are in the high-impedance state.

Device Information

PART NUMBER	PACKAGE ⁽¹⁾	PACKAGE SIZE ⁽²⁾	BODY SIZE ⁽³⁾
SN74HCT244	DB (SSOP, 20)	7.2mm × 7.8mm	7.2mm × 5.3mm
	DW (SOIC, 20)	12.80mm × 10.3mm	12.8mm × 7.5mm
	N (PDIP, 20)	24.33mm × 9.4mm	24.33mm × 6.35mm
	NS (SOP, 20)	12.6mm × 7.8mm	12.6mm × 5.3mm
	PW (TSSOP, 20)	6.5mm × 6.4mm	6.5mm × 4.4mm
	DGS (VSSOP, 20)	5.1mm × 3mm	5.1mm × 4.9mm
SN54HCT244	J (CDIP, 20)	24.2mm × 7.62mm	24.2mm × 7.62mm
	FK (LCCC, 20)	8.89mm × 8.89mm	8.89mm × 8.89mm

- (1) For more information, see [Mechanical, Packaging, and Orderable Information](#).
- (2) The package size (length × width) is a nominal value and includes pins, where applicable.
- (3) The body size (length × width) is a nominal value and does not include pins.

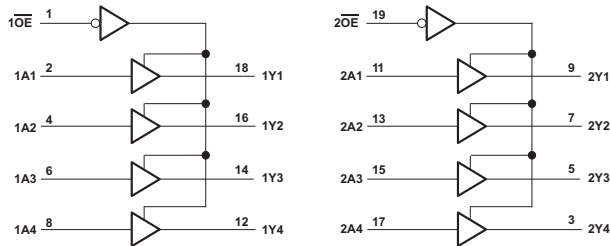

Copyright © 2016, Texas Instruments Incorporated

Logic Diagram (Positive Logic)



Table of Contents

1 Features	1	7.2 Functional Block Diagram.....	9
2 Applications	1	7.3 Feature Description.....	9
3 Description	1	7.4 Device Functional Modes.....	9
4 Pin Configuration and Functions	3	8 Application and Implementation	10
5 Specifications	4	8.1 Application Information.....	10
5.1 Absolute Maximum Ratings.....	4	8.2 Typical Application.....	10
5.2 ESD Ratings.....	4	8.3 Power Supply Recommendations.....	11
5.3 Recommended Operating Conditions.....	4	8.4 Layout.....	11
5.4 Thermal Information.....	5	9 Device and Documentation Support	12
5.5 Electrical Characteristics - SN54HCT244.....	5	9.1 Documentation Support.....	12
5.6 Electrical Characteristics - SN74HCT244.....	6	9.2 Receiving Notification of Documentation Updates....	12
5.7 Switching Characteristics: SN54HCT244.....	6	9.3 Support Resources.....	12
5.8 Switching Characteristics: SN74HCT244.....	7	9.4 Trademarks.....	12
5.9 Operating Characteristics.....	7	9.5 Electrostatic Discharge Caution.....	12
5.10 Typical Characteristics.....	7	9.6 Glossary.....	12
6 Parameter Measurement Information	8	10 Revision History	12
7 Detailed Description	9	11 Mechanical, Packaging, and Orderable Information	13
7.1 Overview.....	9		

4 Pin Configuration and Functions

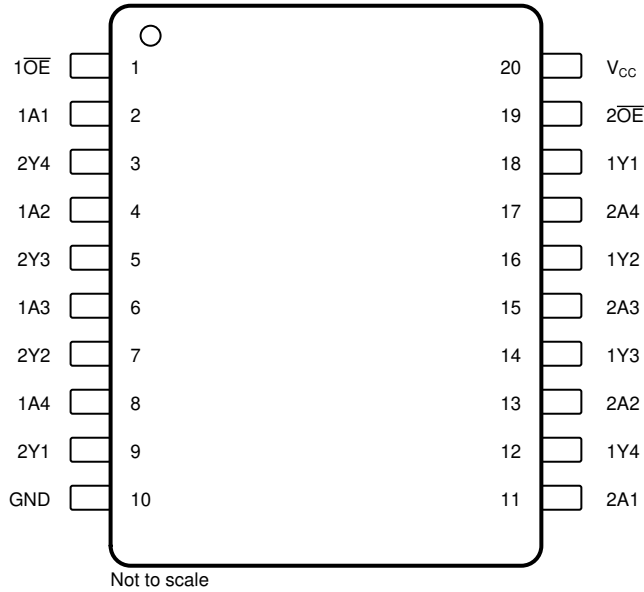

J, DB, DW, N, NS, PW or DGS Packages, 20-Pin CDIP, CFP, SSOP, SOIC, PDIP, SO, TSSOP, or VSSOP (Top View)

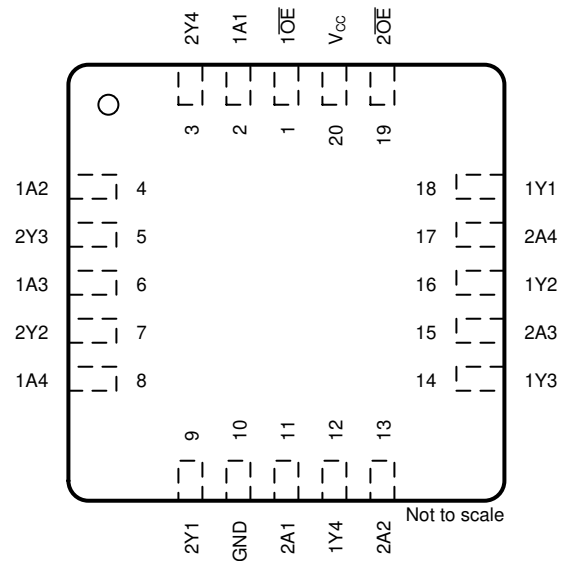

FK Package, 20-Pin LCCC (Top View)

Table 4-1. Pin Functions

PIN		TYPE ⁽¹⁾	DESCRIPTION
NAME	NO.		
1 \overline{OE}	1	I	Output enable
1A1	2	I	Input
2Y4	3	O	Output
1A2	4	I	Input
2Y3	5	O	Output
1A3	6	I	Input
2Y2	7	O	Output
1A4	8	I	Input
2Y1	9	O	Output
GND	10	—	Ground
2A1	11	I	Input
1Y4	12	O	Output
2A2	13	I	Input
1Y3	14	O	Output
2A3	15	I	Input
1Y2	16	O	Output
2A4	17	I	Input
1Y1	18	O	Output
2 \overline{OE}	19	I	Output enable
V _{CC}	20	—	Power pin

(1) Signal Types: I = Input, O = Output, I/O = Input or Output.

5 Specifications

5.1 Absolute Maximum Ratings

over operating free-air temperature range (unless otherwise noted)⁽¹⁾

			MIN	MAX	UNIT
V _{CC}	Supply voltage		-0.5	7	V
I _{IK}	Input clamp current ⁽²⁾	V _I < 0 or V _I > V _{CC}		±20	mA
I _{OK}	Output clamp current ⁽²⁾	V _O < 0 or V _O > V _{CC}		±20	mA
I _O	Continuous output current	V _O = 0 to V _{CC}		±35	mA
	Continuous channel current through V _{CC} or GND			±70	mA
T _J	Junction temperature			150	°C
T _{stg}	Storage temperature		-65	150	°C

- (1) Stresses beyond those listed under *Absolute Maximum Ratings* may cause permanent damage to the device. These are stress ratings only, which do not imply functional operation of the device at these or any other conditions beyond those indicated under *Recommended Operating Conditions*. Exposure to absolute-maximum-rated conditions for extended periods may affect device reliability.
- (2) The input and output voltage ratings may be exceeded if the input and output current ratings are observed.

5.2 ESD Ratings

			VALUE	UNIT
SN74HCT244 in DB, DW, N, NS, or PW package				
V _(ESD)	Electrostatic discharge	Human-body model (HBM), per ANSI/ESDA/JEDEC JS-001 ⁽¹⁾	±2000	V
		Charged-device model (CDM), per JEDEC specification JESD22-C101 ⁽²⁾	±1000	
SN54HCT244 in J or FK package				
V _(ESD)	Electrostatic discharge	Human-body model (HBM)	±1500	V

- (1) JEDEC document JEP155 states that 500-V HBM allows safe manufacturing with a standard ESD control process.
- (2) JEDEC document JEP157 states that 250-V CDM allows safe manufacturing with a standard ESD control process.

5.3 Recommended Operating Conditions

over operating free-air temperature range (unless otherwise noted)⁽¹⁾

			MIN	NOM	MAX	UNIT
V _{CC}	Supply voltage		4.5	5	5.5	V
V _{IH}	High-level input voltage	V _{CC} = 4.5 V to 5.5 V	2			V
V _{IL}	Low-level input voltage	V _{CC} = 4.5 V to 5.5 V			0.8	V
V _I	Input voltage		0		V _{CC}	V
V _O	Output voltage		0		V _{CC}	V
Δt/Δv	Input transition rise and fall time				500	ns
T _A	Operating free-air temperature	SN54HCT244	-55		125	°C
		SN74HCT244 ⁽²⁾	-55		125	
			-40		125	

- (1) All unused inputs of the device must be held at V_{CC} or GND to ensure proper device operation. See the [Implications of Slow or Floating CMOS Inputs](#) application report.
- (2) For correct operating free-air temperature, see the orderable addendum at the end of the data sheet.

5.4 Thermal Information

THERMAL METRIC		SN74HCT244						UNIT
		DW (SOIC)	DB (SSOP)	N (PDIP)	NS (SO)	PW (TSSOP)	DGS (VSSOP)	
		20 PINS	20 PINS	20 PINS	20 PINS	20 PINS	20 PINS	
R _{θJA}	Junction-to-ambient thermal resistance ⁽¹⁾	109.1	122.7	84.6	113.4	131.8	130.6	°C/W
R _{θJC (top)}	Junction-to-case (top) thermal resistance	76	81.6	72.5	78.6	72.2	68.7	°C/W
R _{θJB}	Junction-to-board thermal resistance	77.6	77.5	65.3	78.4	82.8	85.4	°C/W
Ψ _{JT}	Junction-to-top characterization parameter	51.5	46.1	55.3	47.1	21.5	10.5	°C/W
Ψ _{JB}	Junction-to-board characterization parameter	77.1	77.1	65.2	78.1	82.4	85.0	°C/W
R _{θJC (bot)}	Junction-to-case (bottom) thermal resistance	N/A	N/A	N/A	N/A	N/A	N/A	°C/W

(1) For more information about traditional and new thermal metrics, see the [Semiconductor and IC Package Thermal Metrics](#) application report.

5.5 Electrical Characteristics - SN54HCT244

over recommended operating free-air temperature range (unless otherwise noted)

PARAMETER	TEST CONDITIONS		V _{CC}	T _A = 25°C			-55°C to 125°C			UNIT
				MIN	TYP	MAX	MIN	TYP	MAX	
V _{OH}	V _I = V _{IH} or V _{IL}	I _{OH} = -20 μA	4.5 V	4.4	4.499		4.4			V
		I _{OH} = -6 mA		3.98	4.3		3.7			
V _{OL}	V _I = V _{IH} or V _{IL}	I _{OL} = 20 μA	4.5 V		0.001	0.1			0.1	V
		I _{OL} = 6 mA			0.17	0.26			0.4	
I _I	V _I = V _{CC} or 0		5.5 V		±0.1	±100			±1000	nA
I _{OZ}	V _O = V _{CC} or 0, V _I = V _{IH} or V _{IL}		5.5 V		±0.01	±0.5			±10	μA
I _{CC}	V _I = V _{CC} or 0, I _O = 0		5.5 V			8			160	μA
ΔI _{CC} ⁽¹⁾	One input at 0.5 V or 2.4 V, Other inputs at 0 or V _{CC}		5.5 V		1.4	2.4			3	mA
C _i			4.5 V to 5.5 V		3	10			10	pF

(1) This is the increase in supply current for each input that is at one of the specified TTL voltage levels, rather than 0 V or V_{CC}.

5.6 Electrical Characteristics - SN74HCT244

over recommended operating free-air temperature range (unless otherwise noted)

PARAMETER	TEST CONDITIONS		V _{CC}	T _A = 25°C			-55°C to 125°C			UNIT
				MIN	TYP	MAX	MIN	TYP	MAX	
V _{OH}	V _I = V _{IH} or V _{IL}	I _{OH} = -20 μA	4.5 V	4.4	4.499		4.4			V
		I _{OH} = -6 mA		3.98	4.3		3.7			
V _{OL}	V _I = V _{IH} or V _{IL}	I _{OL} = 20 μA	4.5 V		0.001	0.1			0.1	V
		I _{OL} = 6 mA			0.17	0.26		0.4		
I _I	V _I = V _{CC} or 0		5.5 V	±0.1	±100			±1000	nA	
I _{OZ}	V _O = V _{CC} or 0, V _I = V _{IH} or V _{IL}		5.5 V	±0.01	±0.5			±10	μA	
I _{CC}	V _I = V _{CC} or 0, I _O = 0		5.5 V			8		160	μA	
ΔI _{CC} ⁽¹⁾	One input at 0.5 V or 2.4 V, Other inputs at 0 or V _{CC}		5.5 V		1.4	2.4		3	mA	
C _i			4.5 V to 5.5 V		3	10		10	pF	

(1) This is the increase in supply current for each input that is at one of the specified TTL voltage levels, rather than 0 V or V_{CC}.

5.7 Switching Characteristics: SN54HCT244

over recommended operating free-air temperature range (unless otherwise noted) (see [Figure 6-1](#))

PARAMETER	FROM (INPUT)	TO (OUTPUT)	V _{CC}	LOAD CAPACITANCE	T _A = 25°C			-55°C to 125°C		UNIT
					MIN	TYP	MAX	MIN	MAX	
t _{pd}	A	Y	4.5 V	C _L = 50 pF		15	28		42	ns
				C _L = 150 pF		21	45		68	
			5.5 V	C _L = 50 pF		13	25		38	
				C _L = 150 pF		18	40		61	
t _{en}	\overline{OE}	Y	4.5 V	C _L = 50 pF		21	35		53	ns
				C _L = 150 pF		25	52		79	
			5.5 V	C _L = 50 pF		19	32		48	
				C _L = 150 pF		22	47		71	
t _{dis}	\overline{OE}	Y	4.5 V	C _L = 50 pF		19	35		53	ns
			5.5 V	C _L = 50 pF		18	32		48	
t _t		Y	4.5 V	C _L = 50 pF		8	12		18	ns
				C _L = 150 pF		17	42		63	
			5.5 V	C _L = 50 pF		7	11		16	
				C _L = 150 pF		14	38		57	

5.8 Switching Characteristics: SN74HCT244

over recommended operating free-air temperature range (unless otherwise noted) (see Figure 6-1)

PARAMETER	FROM (INPUT)	TO (OUTPUT)	V _{CC}	LOAD CAPACITANCE	T _A = 25°C			-55°C to 125°C		UNIT
					MIN	TYP	MAX	MIN	MAX	
t _{pd}	A	Y	4.5 V	C _L = 50 pF	15	28	42	ns		
				C _L = 150 pF	21	45	68			
			5.5 V	C _L = 50 pF	13	25	38			
				C _L = 150 pF	18	40	61			
t _{en}	OE	Y	4.5 V	C _L = 50 pF	21	35	53	ns		
				C _L = 150 pF	25	52	79			
			5.5 V	C _L = 50 pF	19	32	48			
				C _L = 150 pF	22	47	71			
t _{dis}	OE	Y	4.5 V	C _L = 50 pF	19	35	53	ns		
			5.5 V	C _L = 50 pF	18	32	48			
t _t		Y	4.5 V	C _L = 50 pF	8	12	18	ns		
				C _L = 150 pF	17	42	63			
			5.5 V	C _L = 50 pF	7	11	16			
				C _L = 150 pF	14	38	57			

5.9 Operating Characteristics

T_A = 25°C

PARAMETER	TEST CONDITIONS	TYP	UNIT
C _{pd} Power dissipation capacitance per buffer or driver	No load	40	pF

5.10 Typical Characteristics

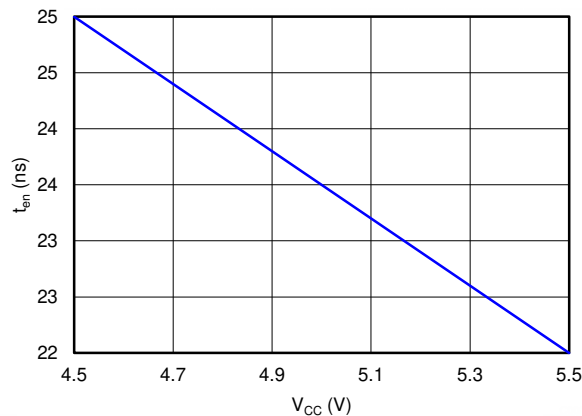
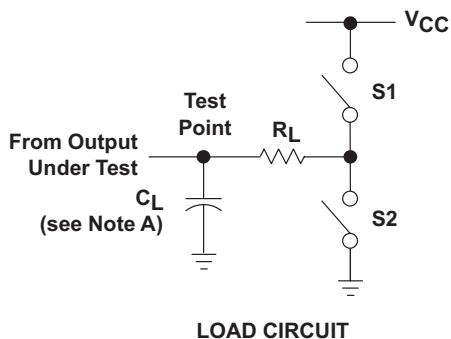
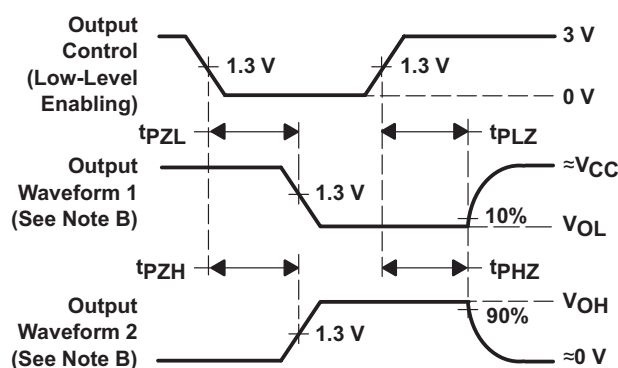
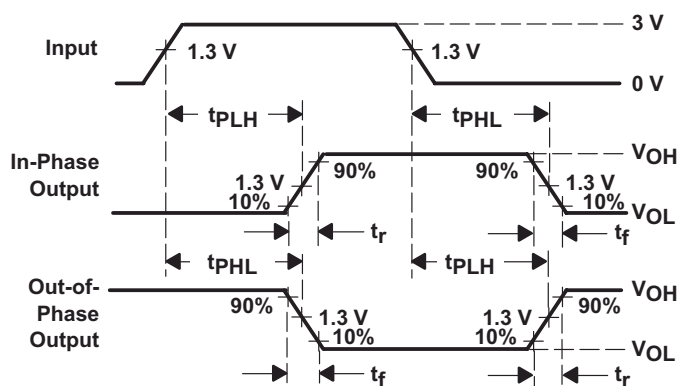
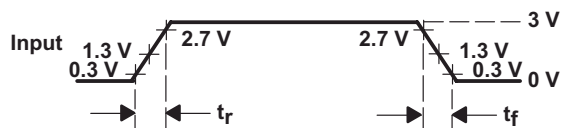

Figure 5-1. Enable Time vs V_{CC}

6 Parameter Measurement Information



PARAMETER	R_L	C_L	S1	S2
t_{en}	1 k Ω	50 pF or 150 pF	Open	Closed
			Closed	Open
t_{dis}	1 k Ω	50 pF	Open	Closed
			Closed	Open
t_{pd} or t_t	—	50 pF or 150 pF	Open	Open



- NOTES:
- A. C_L includes probe and test-fixture capacitance.
 - B. Waveform 1 is for an output with internal conditions such that the output is low except when disabled by the output control. Waveform 2 is for an output with internal conditions such that the output is high except when disabled by the output control.
 - C. Phase relationships between waveforms were chosen arbitrarily. All input pulses are supplied by generators having the following characteristics: $PRR \leq 1$ MHz, $Z_O = 50 \Omega$, $t_r = 6$ ns, $t_f = 6$ ns.
 - D. The outputs are measured one at a time with one input transition per measurement.
 - E. t_{PLZ} and t_{PHZ} are the same as t_{dis} .
 - F. t_{PZL} and t_{PZH} are the same as t_{en} .
 - G. t_{PLH} and t_{PHL} are the same as t_{pd} .

Figure 6-1. Load Circuit and Voltage Waveforms

7 Detailed Description

7.1 Overview

The SNx4HCT244 device is organized as two 4-bit buffers and line drivers with separate output-enable (\overline{OE}) inputs. When \overline{OE} is low, the device passes data from the A inputs to the Y outputs. When \overline{OE} is high, the outputs are in the high-impedance state. For the high-impedance state during power up or power down, \overline{OE} must be tied to V_{CC} through a pullup resistor; the minimum value of the resistor is determined by the current-sinking capability of the driver.

7.2 Functional Block Diagram

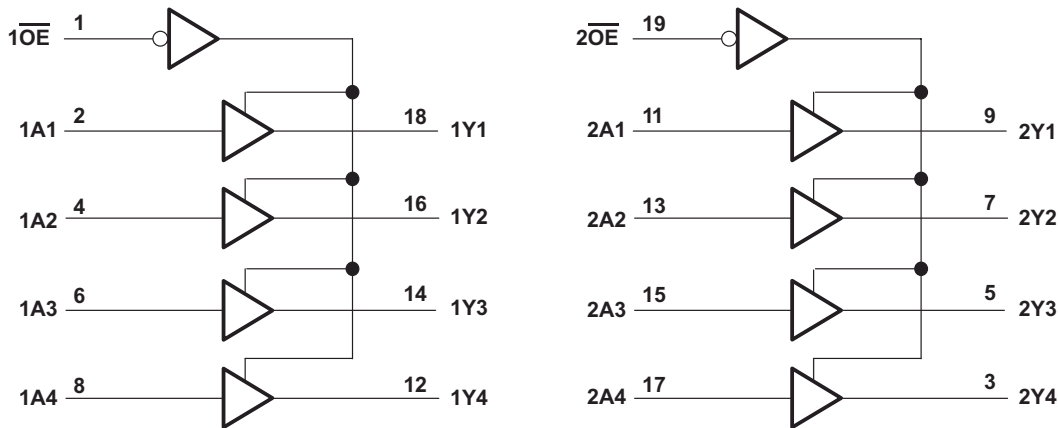

Copyright © 2016, Texas Instruments Incorporated

Figure 7-1. Logic Diagram (Positive Logic)

7.3 Feature Description

The SN74HCT244 device can drive up to 15 LSTTL loads. This device has low power consumption of $80\text{-}\mu\text{A } I_{CC}$. The SN74HCT244 also has 3 state outputs that allow the outputs to go to high impedance, low or high.

7.4 Device Functional Modes

Table 7-1 lists the functions of the SNx4HC244.

Table 7-1. Function Table

INPUTS		OUTPUT Y
OE	A	
L	H	H
L	L	L
H	X	Z

8 Application and Implementation

Note

Information in the following applications sections is not part of the TI component specification, and TI does not warrant its accuracy or completeness. TI's customers are responsible for determining suitability of components for their purposes, as well as validating and testing their design implementation to confirm system functionality.

8.1 Application Information

The SN74HC244 is a high-drive CMOS device that can be used for a multitude of bus interface type applications where output drive or PCB trace length is a concern.

8.2 Typical Application

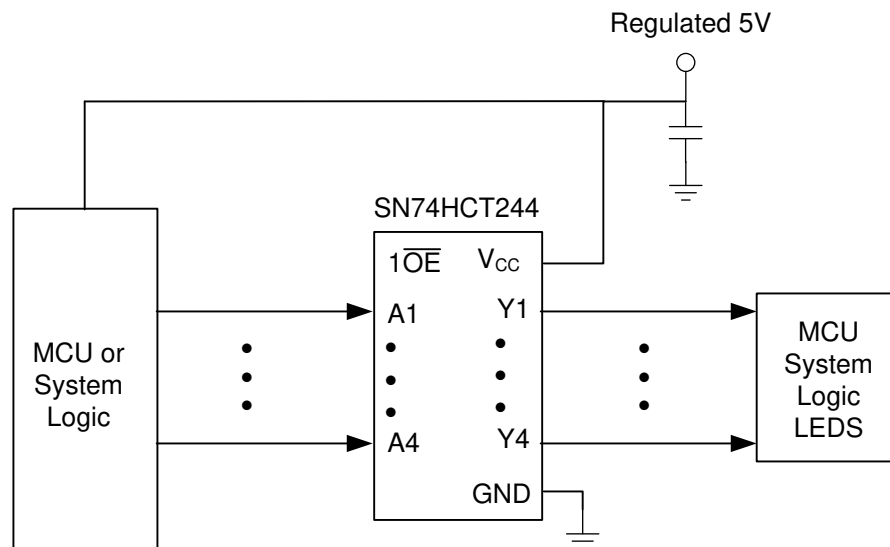

Copyright © 2016, Texas Instruments Incorporated

Figure 8-1. Application Schematic

8.2.1 Design Requirements

This device uses CMOS technology and has balanced output drive. Avoid bus contention because it can drive currents in excess of maximum limits. The high drive creates fast edges into light loads, so consider routing and load conditions to prevent ringing.

8.2.2 Detailed Design Procedure

- Recommended input conditions:
 - For rise time and fall time specifications, see $\Delta t/\Delta V$ in [Recommended Operating Conditions](#).
 - For specified high and low levels, see V_{IH} and V_{IL} in [Recommended Operating Conditions](#).
- Recommend output conditions:
 - Load currents must not exceed the I_O maximum per output and must not exceed the continuous current through V_{CC} or GND total current for the part. These limits are located in [Absolute Maximum Ratings](#).
 - Outputs must not be pulled above V_{CC} .

8.2.3 Application Curve

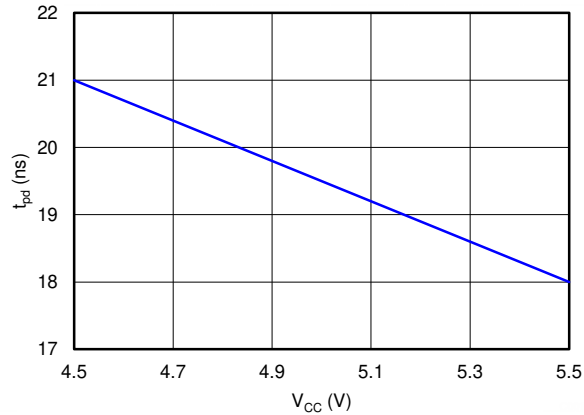

Figure 8-2. Propagation Delay vs V_{CC}

8.3 Power Supply Recommendations

The power supply can be any voltage between the minimum and maximum supply voltage rating located in [Recommended Operating Conditions](#).

Each V_{CC} terminal must have a good bypass capacitor to prevent power disturbance. For devices with a single supply, TI recommends a 0.1-μF capacitor. If there are multiple V_{CC} terminals, then TI recommends 0.01-μF or 0.022-μF capacitors for each power terminal. It is okay to parallel multiple bypass capacitors to reject different frequencies of noise. Multiple bypass capacitors may be paralleled to reject different frequencies of noise. The bypass capacitor must be installed as close to the power terminal as possible for the best results.

8.4 Layout

8.4.1 Layout Guidelines

When using multiple bit logic devices, inputs must not float. In many cases, functions or parts of functions of digital logic devices are unused. Some examples are when only two inputs of a triple-input and gate are used, or when only 3 of the 4-buffer gates are used. Such input pins must not be left unconnected because the undefined voltages at the outside connections result in undefined operational states.

Specified in [Figure 8-3](#) are rules that must be observed under all circumstances. All unused inputs of digital logic devices must be connected to a high or low bias to prevent them from floating. The logic level that must be applied to any particular unused input depends on the function of the device. Generally they are tied to GND or V_{CC}, whichever makes more sense or is more convenient.

8.4.2 Layout Example

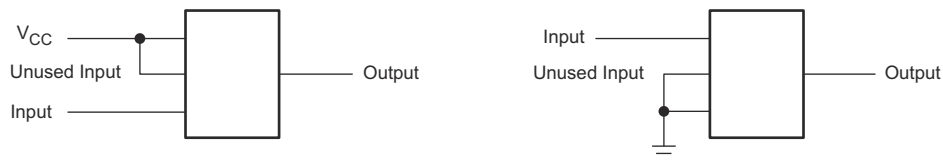

Figure 8-3. Layout Diagram

9 Device and Documentation Support

9.1 Documentation Support

9.1.1 Related Documentation

For related documentation, see the following:

- Texas Instruments, [Implications of Slow or Floating CMOS Inputs](#)

9.2 Receiving Notification of Documentation Updates

To receive notification of documentation updates, navigate to the device product folder on [ti.com](#). Click on *Notifications* to register and receive a weekly digest of any product information that has changed. For change details, review the revision history included in any revised document.

9.3 Support Resources

TI E2E™ [support forums](#) are an engineer's go-to source for fast, verified answers and design help — straight from the experts. Search existing answers or ask your own question to get the quick design help you need.

Linked content is provided "AS IS" by the respective contributors. They do not constitute TI specifications and do not necessarily reflect TI's views; see TI's [Terms of Use](#).

9.4 Trademarks

TI E2E™ is a trademark of Texas Instruments.

All trademarks are the property of their respective owners.

9.5 Electrostatic Discharge Caution



This integrated circuit can be damaged by ESD. Texas Instruments recommends that all integrated circuits be handled with appropriate precautions. Failure to observe proper handling and installation procedures can cause damage.

ESD damage can range from subtle performance degradation to complete device failure. Precision integrated circuits may be more susceptible to damage because very small parametric changes could cause the device not to meet its published specifications.

9.6 Glossary

[TI Glossary](#) This glossary lists and explains terms, acronyms, and definitions.

10 Revision History

NOTE: Page numbers for previous revisions may differ from page numbers in the current version.

Changes from Revision H (August 2023) to Revision I (February 2025)	Page
• Updated SN74HCT244 operating temperature to 125°C and respective values in <i>Electrical Characteristics</i> table, <i>Recommended Operating Conditions</i> table, and <i>Switching Characteristics</i> tables.....	1
• Added package size to <i>Device Information</i> table and updated structural layout of data sheet to current standards.....	1

Changes from Revision G (December 2022) to Revision H (August 2023)	Page
• Added supporting information for the DGS (SOT) package.....	1
• Updated the <i>Device Information</i> table to include rating.....	1
• Removed the <i>W (CFP, 20)</i> package from the data sheet.....	1

11 Mechanical, Packaging, and Orderable Information

The following pages include mechanical, packaging, and orderable information. This information is the most current data available for the designated devices. This data is subject to change without notice and revision of this document. For browser-based versions of this data sheet, refer to the left-hand navigation.

PACKAGING INFORMATION

Orderable part number	Status (1)	Material type (2)	Package Pins	Package qty Carrier	RoHS (3)	Lead finish/ Ball material (4)	MSL rating/ Peak reflow (5)	Op temp (°C)	Part marking (6)
5962-8513001VRA	Active	Production	CDIP (J) 20	20 TUBE	No	SNPB	N/A for Pkg Type	-55 to 125	5962-8513001VR A SNV54HCT244J
5962-8513001VRA.A	Active	Production	CDIP (J) 20	20 TUBE	No	SNPB	N/A for Pkg Type	-55 to 125	5962-8513001VR A SNV54HCT244J
5962-8513001VSA	Active	Production	CFP (W) 20	25 TUBE	No	SNPB	N/A for Pkg Type	-55 to 125	5962-8513001VS A SNV54HCT244W
5962-8513001VSA.A	Active	Production	CFP (W) 20	25 TUBE	No	SNPB	N/A for Pkg Type	-55 to 125	5962-8513001VS A SNV54HCT244W
85130012A	Active	Production	LCCC (FK) 20	55 TUBE	No	SNPB	N/A for Pkg Type	-55 to 125	85130012A SNJ54HCT 244FK
8513001RA	Active	Production	CDIP (J) 20	20 TUBE	No	SNPB	N/A for Pkg Type	-55 to 125	8513001RA SNJ54HCT244J
JM38510/65755B2A	Active	Production	LCCC (FK) 20	55 TUBE	No	SNPB	N/A for Pkg Type	-55 to 125	JM38510/ 65755B2A
JM38510/65755B2A.A	Active	Production	LCCC (FK) 20	55 TUBE	No	SNPB	N/A for Pkg Type	-55 to 125	JM38510/ 65755B2A
JM38510/65755BRA	Active	Production	CDIP (J) 20	20 TUBE	No	SNPB	N/A for Pkg Type	-55 to 125	JM38510/ 65755BRA
JM38510/65755BRA.A	Active	Production	CDIP (J) 20	20 TUBE	No	SNPB	N/A for Pkg Type	-55 to 125	JM38510/ 65755BRA
M38510/65755B2A	Active	Production	LCCC (FK) 20	55 TUBE	No	SNPB	N/A for Pkg Type	-55 to 125	JM38510/ 65755B2A
M38510/65755BRA	Active	Production	CDIP (J) 20	20 TUBE	No	SNPB	N/A for Pkg Type	-55 to 125	JM38510/ 65755BRA
SN54HCT244J	Active	Production	CDIP (J) 20	20 TUBE	No	SNPB	N/A for Pkg Type	-55 to 125	SN54HCT244J
SN54HCT244J.A	Active	Production	CDIP (J) 20	20 TUBE	No	SNPB	N/A for Pkg Type	-55 to 125	SN54HCT244J
SN74HCT244DBR	Active	Production	SSOP (DB) 20	2000 LARGE T&R	Yes	NIPDAU	Level-1-260C-UNLIM	-40 to 85	HT244
SN74HCT244DBR.A	Active	Production	SSOP (DB) 20	2000 LARGE T&R	Yes	NIPDAU	Level-1-260C-UNLIM	-40 to 85	HT244

Orderable part number	Status (1)	Material type (2)	Package Pins	Package qty Carrier	RoHS (3)	Lead finish/ Ball material (4)	MSL rating/ Peak reflow (5)	Op temp (°C)	Part marking (6)
SN74HCT244DGSR	Active	Production	VSSOP (DGS) 20	5000 LARGE T&R	Yes	NIPDAU	Level-1-260C-UNLIM	-40 to 125	HT244
SN74HCT244DGSR.A	Active	Production	VSSOP (DGS) 20	5000 LARGE T&R	Yes	NIPDAU	Level-1-260C-UNLIM	-40 to 125	HT244
SN74HCT244DW	Obsolete	Production	SOIC (DW) 20	-	-	Call TI	Call TI	-40 to 85	HCT244
SN74HCT244DWR	Active	Production	SOIC (DW) 20	2000 LARGE T&R	Yes	NIPDAU	Level-1-260C-UNLIM	-40 to 125	HCT244
SN74HCT244DWR.A	Active	Production	SOIC (DW) 20	2000 LARGE T&R	Yes	NIPDAU	Level-1-260C-UNLIM	-40 to 85	HCT244
SN74HCT244DWRE4	Active	Production	SOIC (DW) 20	2000 LARGE T&R	Yes	NIPDAU	Level-1-260C-UNLIM	-40 to 85	HCT244
SN74HCT244DWRG4	Active	Production	SOIC (DW) 20	2000 LARGE T&R	Yes	NIPDAU	Level-1-260C-UNLIM	-40 to 85	HCT244
SN74HCT244N	Active	Production	PDIP (N) 20	20 TUBE	Yes	NIPDAU	N/A for Pkg Type	-40 to 85	SN74HCT244N
SN74HCT244N.A	Active	Production	PDIP (N) 20	20 TUBE	Yes	NIPDAU	N/A for Pkg Type	-40 to 85	SN74HCT244N
SN74HCT244NE4	Active	Production	PDIP (N) 20	20 TUBE	Yes	NIPDAU	N/A for Pkg Type	-40 to 85	SN74HCT244N
SN74HCT244NSR	Active	Production	SOP (NS) 20	2000 LARGE T&R	Yes	NIPDAU	Level-1-260C-UNLIM	-40 to 85	HCT244
SN74HCT244NSR.A	Active	Production	SOP (NS) 20	2000 LARGE T&R	Yes	NIPDAU	Level-1-260C-UNLIM	-40 to 85	HCT244
SN74HCT244PW	Obsolete	Production	TSSOP (PW) 20	-	-	Call TI	Call TI	-40 to 85	HT244
SN74HCT244PWR	Active	Production	TSSOP (PW) 20	2000 LARGE T&R	Yes	NIPDAU	Level-1-260C-UNLIM	-40 to 125	HT244
SN74HCT244PWR.A	Active	Production	TSSOP (PW) 20	2000 LARGE T&R	Yes	NIPDAU	Level-1-260C-UNLIM	-40 to 125	HT244
SN74HCT244PWRG4	Active	Production	TSSOP (PW) 20	2000 LARGE T&R	Yes	NIPDAU	Level-1-260C-UNLIM	-40 to 125	HT244
SN74HCT244PWRG4.A	Active	Production	TSSOP (PW) 20	2000 LARGE T&R	Yes	NIPDAU	Level-1-260C-UNLIM	-40 to 125	HT244
SN74HCT244PWT	Obsolete	Production	TSSOP (PW) 20	-	-	Call TI	Call TI	-40 to 85	HT244
SNJ54HCT244FK	Active	Production	LCCC (FK) 20	55 TUBE	No	SNPB	N/A for Pkg Type	-55 to 125	85130012A SNJ54HCT 244FK
SNJ54HCT244FK.A	Active	Production	LCCC (FK) 20	55 TUBE	No	SNPB	N/A for Pkg Type	-55 to 125	85130012A SNJ54HCT 244FK
SNJ54HCT244J	Active	Production	CDIP (J) 20	20 TUBE	No	SNPB	N/A for Pkg Type	-55 to 125	8513001RA SNJ54HCT244J
SNJ54HCT244J.A	Active	Production	CDIP (J) 20	20 TUBE	No	SNPB	N/A for Pkg Type	-55 to 125	8513001RA SNJ54HCT244J

⁽¹⁾ **Status:** For more details on status, see our [product life cycle](#).

(2) **Material type:** When designated, preproduction parts are prototypes/experimental devices, and are not yet approved or released for full production. Testing and final process, including without limitation quality assurance, reliability performance testing, and/or process qualification, may not yet be complete, and this item is subject to further changes or possible discontinuation. If available for ordering, purchases will be subject to an additional waiver at checkout, and are intended for early internal evaluation purposes only. These items are sold without warranties of any kind.

(3) **RoHS values:** Yes, No, RoHS Exempt. See the [TI RoHS Statement](#) for additional information and value definition.

(4) **Lead finish/Ball material:** Parts may have multiple material finish options. Finish options are separated by a vertical ruled line. Lead finish/Ball material values may wrap to two lines if the finish value exceeds the maximum column width.

(5) **MSL rating/Peak reflow:** The moisture sensitivity level ratings and peak solder (reflow) temperatures. In the event that a part has multiple moisture sensitivity ratings, only the lowest level per JEDEC standards is shown. Refer to the shipping label for the actual reflow temperature that will be used to mount the part to the printed circuit board.

(6) **Part marking:** There may be an additional marking, which relates to the logo, the lot trace code information, or the environmental category of the part.

Multiple part markings will be inside parentheses. Only one part marking contained in parentheses and separated by a "~" will appear on a part. If a line is indented then it is a continuation of the previous line and the two combined represent the entire part marking for that device.

Important Information and Disclaimer: The information provided on this page represents TI's knowledge and belief as of the date that it is provided. TI bases its knowledge and belief on information provided by third parties, and makes no representation or warranty as to the accuracy of such information. Efforts are underway to better integrate information from third parties. TI has taken and continues to take reasonable steps to provide representative and accurate information but may not have conducted destructive testing or chemical analysis on incoming materials and chemicals. TI and TI suppliers consider certain information to be proprietary, and thus CAS numbers and other limited information may not be available for release.

In no event shall TI's liability arising out of such information exceed the total purchase price of the TI part(s) at issue in this document sold by TI to Customer on an annual basis.

OTHER QUALIFIED VERSIONS OF SN54HCT244, SN54HCT244-SP, SN74HCT244 :

- Catalog : [SN74HCT244](#), [SN54HCT244](#)
- Automotive : [SN74HCT244-Q1](#), [SN74HCT244-Q1](#)
- Enhanced Product : [SN74HCT244-EP](#), [SN74HCT244-EP](#)
- Military : [SN54HCT244](#)
- Space : [SN54HCT244-SP](#)

NOTE: Qualified Version Definitions:

- Catalog - TI's standard catalog product
- Automotive - Q100 devices qualified for high-reliability automotive applications targeting zero defects
- Enhanced Product - Supports Defense, Aerospace and Medical Applications
- Military - QML certified for Military and Defense Applications
- Space - Radiation tolerant, ceramic packaging and qualified for use in Space-based application

TAPE AND REEL INFORMATION

QUADRANT ASSIGNMENTS FOR PIN 1 ORIENTATION IN TAPE

*All dimensions are nominal

Device	Package Type	Package Drawing	Pins	SPQ	Reel Diameter (mm)	Reel Width W1 (mm)	A0 (mm)	B0 (mm)	K0 (mm)	P1 (mm)	W (mm)	Pin1 Quadrant
SN74HCT244DBR	SSOP	DB	20	2000	330.0	16.4	8.2	7.5	2.5	12.0	16.0	Q1
SN74HCT244DGSR	VSSOP	DGS	20	5000	330.0	16.4	5.4	5.4	1.45	8.0	16.0	Q1
SN74HCT244DWR	SOIC	DW	20	2000	330.0	24.4	10.9	13.3	2.7	12.0	24.0	Q1
SN74HCT244NSR	SOP	NS	20	2000	330.0	24.4	8.4	13.0	2.5	12.0	24.0	Q1
SN74HCT244PWR	TSSOP	PW	20	2000	330.0	16.4	6.95	7.0	1.4	8.0	16.0	Q1
SN74HCT244PWRG4	TSSOP	PW	20	2000	330.0	16.4	6.95	7.0	1.4	8.0	16.0	Q1
SN74HCT244PWRG4	TSSOP	PW	20	2000	330.0	16.4	6.95	7.0	1.4	8.0	16.0	Q1

TAPE AND REEL BOX DIMENSIONS

*All dimensions are nominal

Device	Package Type	Package Drawing	Pins	SPQ	Length (mm)	Width (mm)	Height (mm)
SN74HCT244DBR	SSOP	DB	20	2000	353.0	353.0	32.0
SN74HCT244DGSR	VSSOP	DGS	20	5000	353.0	353.0	32.0
SN74HCT244DWR	SOIC	DW	20	2000	356.0	356.0	45.0
SN74HCT244NSR	SOP	NS	20	2000	356.0	356.0	45.0
SN74HCT244PWR	TSSOP	PW	20	2000	353.0	353.0	32.0
SN74HCT244PWRG4	TSSOP	PW	20	2000	353.0	353.0	32.0
SN74HCT244PWRG4	TSSOP	PW	20	2000	353.0	353.0	32.0

TUBE

*All dimensions are nominal

Device	Package Name	Package Type	Pins	SPQ	L (mm)	W (mm)	T (μm)	B (mm)
5962-8513001VSA	W	CFP	20	25	506.98	26.16	6220	NA
5962-8513001VSA.A	W	CFP	20	25	506.98	26.16	6220	NA
85130012A	FK	LCCC	20	55	506.98	12.06	2030	NA
JM38510/65755B2A	FK	LCCC	20	55	506.98	12.06	2030	NA
JM38510/65755B2A.A	FK	LCCC	20	55	506.98	12.06	2030	NA
M38510/65755B2A	FK	LCCC	20	55	506.98	12.06	2030	NA
SN74HCT244N	N	PDIP	20	20	506	13.97	11230	4.32
SN74HCT244N.A	N	PDIP	20	20	506	13.97	11230	4.32
SN74HCT244NE4	N	PDIP	20	20	506	13.97	11230	4.32
SNJ54HCT244FK	FK	LCCC	20	55	506.98	12.06	2030	NA
SNJ54HCT244FK.A	FK	LCCC	20	55	506.98	12.06	2030	NA

J (R-GDIP-T**)

14 LEADS SHOWN

CERAMIC DUAL IN-LINE PACKAGE



DIM \ PINS **	14	16	18	20
A	0.300 (7,62) BSC	0.300 (7,62) BSC	0.300 (7,62) BSC	0.300 (7,62) BSC
B MAX	0.785 (19,94)	.840 (21,34)	0.960 (24,38)	1.060 (26,92)
B MIN	—	—	—	—
C MAX	0.300 (7,62)	0.300 (7,62)	0.310 (7,87)	0.300 (7,62)
C MIN	0.245 (6,22)	0.245 (6,22)	0.220 (5,59)	0.245 (6,22)



4040083/F 03/03

- NOTES:
- All linear dimensions are in inches (millimeters).
 - This drawing is subject to change without notice.
 - This package is hermetically sealed with a ceramic lid using glass frit.
 - Index point is provided on cap for terminal identification only on press ceramic glass frit seal only.
 - Falls within MIL STD 1835 GDIP1-T14, GDIP1-T16, GDIP1-T18 and GDIP1-T20.

GENERIC PACKAGE VIEW

FK 20

LCCC - 2.03 mm max height

8.89 x 8.89, 1.27 mm pitch

LEADLESS CERAMIC CHIP CARRIER

This image is a representation of the package family, actual package may vary.
Refer to the product data sheet for package details.



4229370VA\

N (R-PDIP-T**)

PLASTIC DUAL-IN-LINE PACKAGE

16 PINS SHOWN



4040049/E 12/2002

- NOTES:
- A. All linear dimensions are in inches (millimeters).
 - B. This drawing is subject to change without notice.
 - $\triangle C$ Falls within JEDEC MS-001, except 18 and 20 pin minimum body length (Dim A).
 - $\triangle D$ The 20 pin end lead shoulder width is a vendor option, either half or full width.

DW0020A



PACKAGE OUTLINE

SOIC - 2.65 mm max height

SOIC



NOTES:

1. All linear dimensions are in millimeters. Dimensions in parenthesis are for reference only. Dimensioning and tolerancing per ASME Y14.5M.
2. This drawing is subject to change without notice.
3. This dimension does not include mold flash, protrusions, or gate burrs. Mold flash, protrusions, or gate burrs shall not exceed 0.15 mm per side.
4. This dimension does not include interlead flash. Interlead flash shall not exceed 0.43 mm per side.
5. Reference JEDEC registration MS-013.

EXAMPLE BOARD LAYOUT

DW0020A

SOIC - 2.65 mm max height

SOIC



LAND PATTERN EXAMPLE
SCALE:6X



SOLDER MASK DETAILS

4220724/A 05/2016

NOTES: (continued)

- 6. Publication IPC-7351 may have alternate designs.
- 7. Solder mask tolerances between and around signal pads can vary based on board fabrication site.

EXAMPLE STENCIL DESIGN

DW0020A

SOIC - 2.65 mm max height

SOIC



SOLDER PASTE EXAMPLE
BASED ON 0.125 mm THICK STENCIL
SCALE:6X

4220724/A 05/2016

NOTES: (continued)

8. Laser cutting apertures with trapezoidal walls and rounded corners may offer better paste release. IPC-7525 may have alternate design recommendations.
9. Board assembly site may have different recommendations for stencil design.

W (R-GDFP-F20)

CERAMIC DUAL FLATPACK



- NOTES:
- A. All linear dimensions are in inches (millimeters).
 - B. This drawing is subject to change without notice.
 - C. This package can be hermetically sealed with a ceramic lid using glass frit.
 - D. Index point is provided on cap for terminal identification only.
 - E. Falls within Mil-Std 1835 GDFP2-F20

PW0020A



PACKAGE OUTLINE

TSSOP - 1.2 mm max height

SMALL OUTLINE PACKAGE



4220206/A 02/2017

NOTES:

1. All linear dimensions are in millimeters. Any dimensions in parenthesis are for reference only. Dimensioning and tolerancing per ASME Y14.5M.
2. This drawing is subject to change without notice.
3. This dimension does not include mold flash, protrusions, or gate burrs. Mold flash, protrusions, or gate burrs shall not exceed 0.15 mm per side.
4. This dimension does not include interlead flash. Interlead flash shall not exceed 0.25 mm per side.
5. Reference JEDEC registration MO-153.

EXAMPLE BOARD LAYOUT

PW0020A

TSSOP - 1.2 mm max height

SMALL OUTLINE PACKAGE



LAND PATTERN EXAMPLE
EXPOSED METAL SHOWN
SCALE: 10X



SOLDER MASK DETAILS

4220206/A 02/2017

NOTES: (continued)

- 6. Publication IPC-7351 may have alternate designs.
- 7. Solder mask tolerances between and around signal pads can vary based on board fabrication site.

EXAMPLE STENCIL DESIGN

PW0020A

TSSOP - 1.2 mm max height

SMALL OUTLINE PACKAGE



SOLDER PASTE EXAMPLE
BASED ON 0.125 mm THICK STENCIL
SCALE: 10X

4220206/A 02/2017

NOTES: (continued)

8. Laser cutting apertures with trapezoidal walls and rounded corners may offer better paste release. IPC-7525 may have alternate design recommendations.
9. Board assembly site may have different recommendations for stencil design.

DGS0020A



PACKAGE OUTLINE

VSSOP - 1.1 mm max height

SMALL OUTLINE PACKAGE

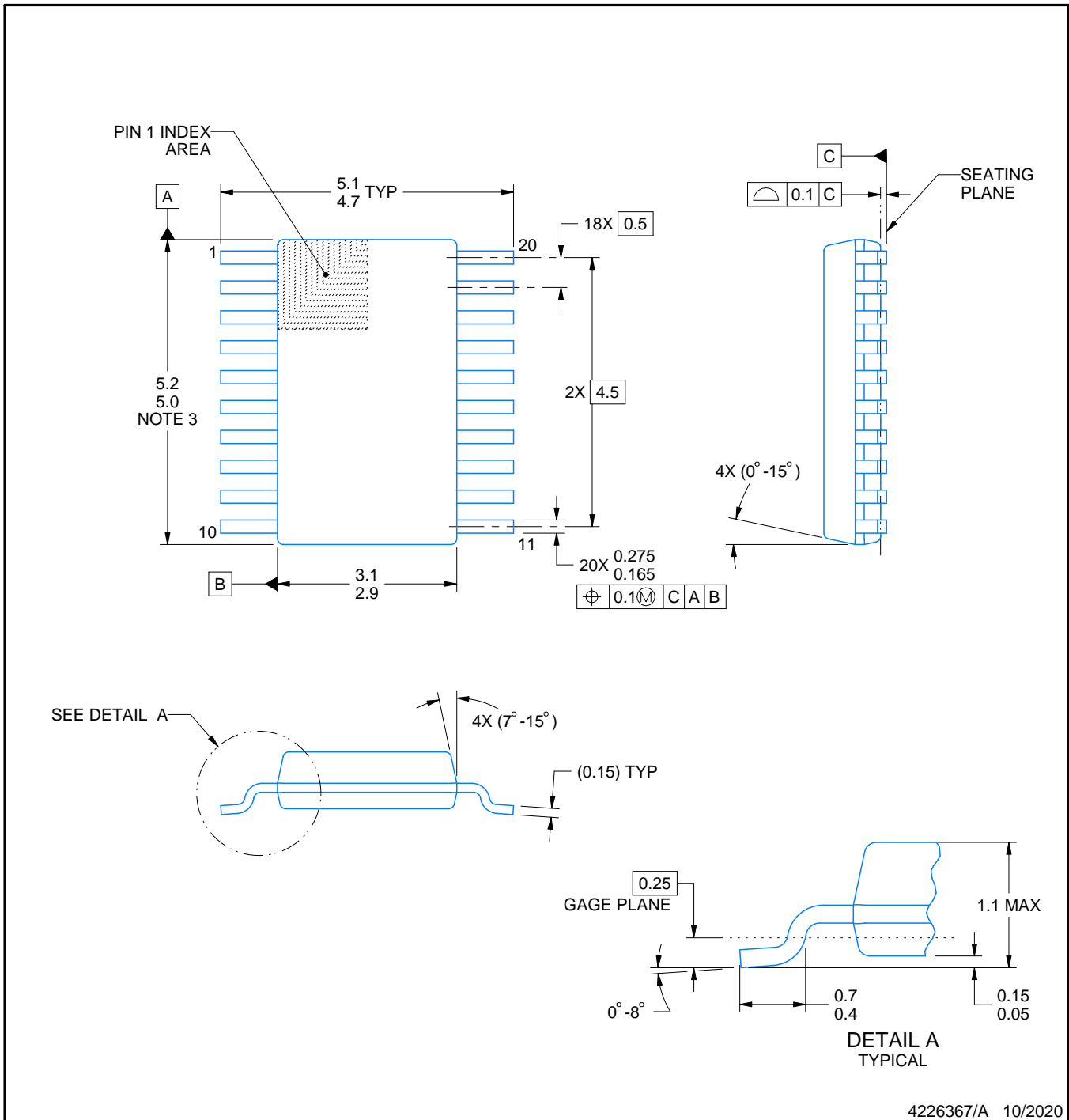

4226367/A 10/2020

NOTES:

PowerPAD is a trademark of Texas Instruments.

1. All linear dimensions are in millimeters. Any dimensions in parenthesis are for reference only. Dimensioning and tolerancing per ASME Y14.5M.
2. This drawing is subject to change without notice.
3. This dimension does not include mold flash, protrusions, or gate burrs. Mold flash, protrusions, or gate burrs shall not exceed 0.15 mm per side.
4. No JEDEC registration as of September 2020.
5. Features may differ or may not be present.

EXAMPLE BOARD LAYOUT

DGS0020A

VSSOP - 1.1 mm max height

SMALL OUTLINE PACKAGE

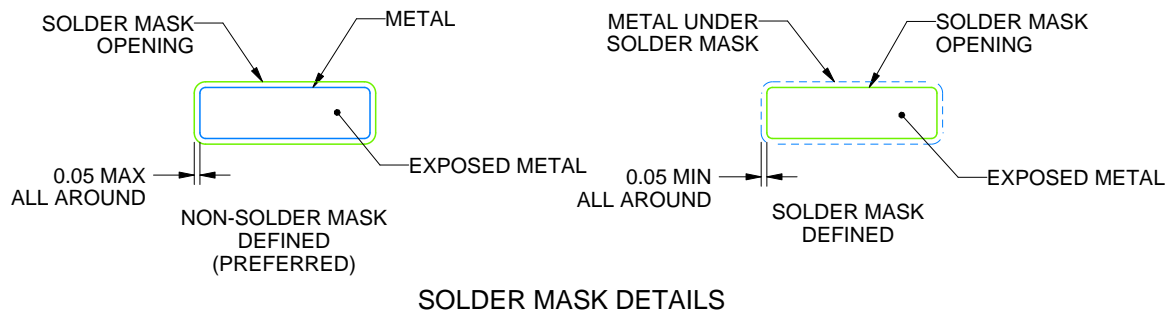
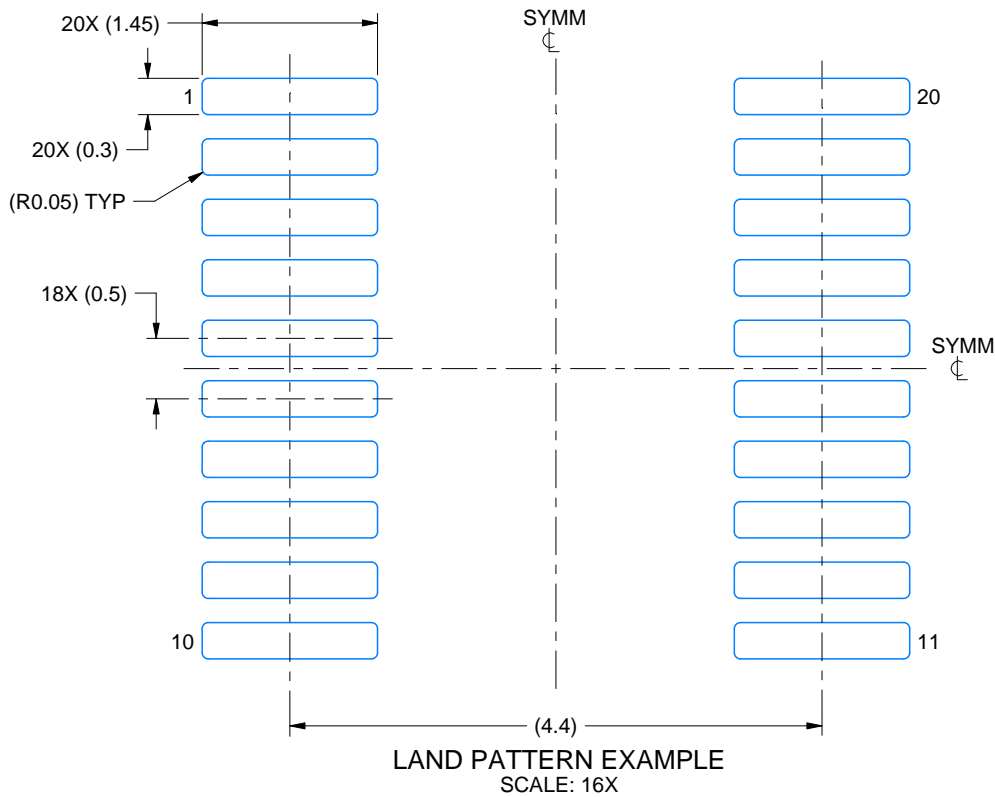

4226367/A 10/2020

NOTES: (continued)

6. Publication IPC-7351 may have alternate designs.
7. Solder mask tolerances between and around signal pads can vary based on board fabrication site.
8. This package is designed to be soldered to a thermal pad on the board. For more information, see Texas Instruments literature numbers SLMA002 (www.ti.com/lit/slma002) and SLMA004 (www.ti.com/lit/slma004).
9. Size of metal pad may vary due to creepage requirement.
10. Vias are optional depending on application, refer to device data sheet. It is recommended that vias under paste be filled, plugged or tented.

EXAMPLE STENCIL DESIGN

DGS0020A

VSSOP - 1.1 mm max height

SMALL OUTLINE PACKAGE

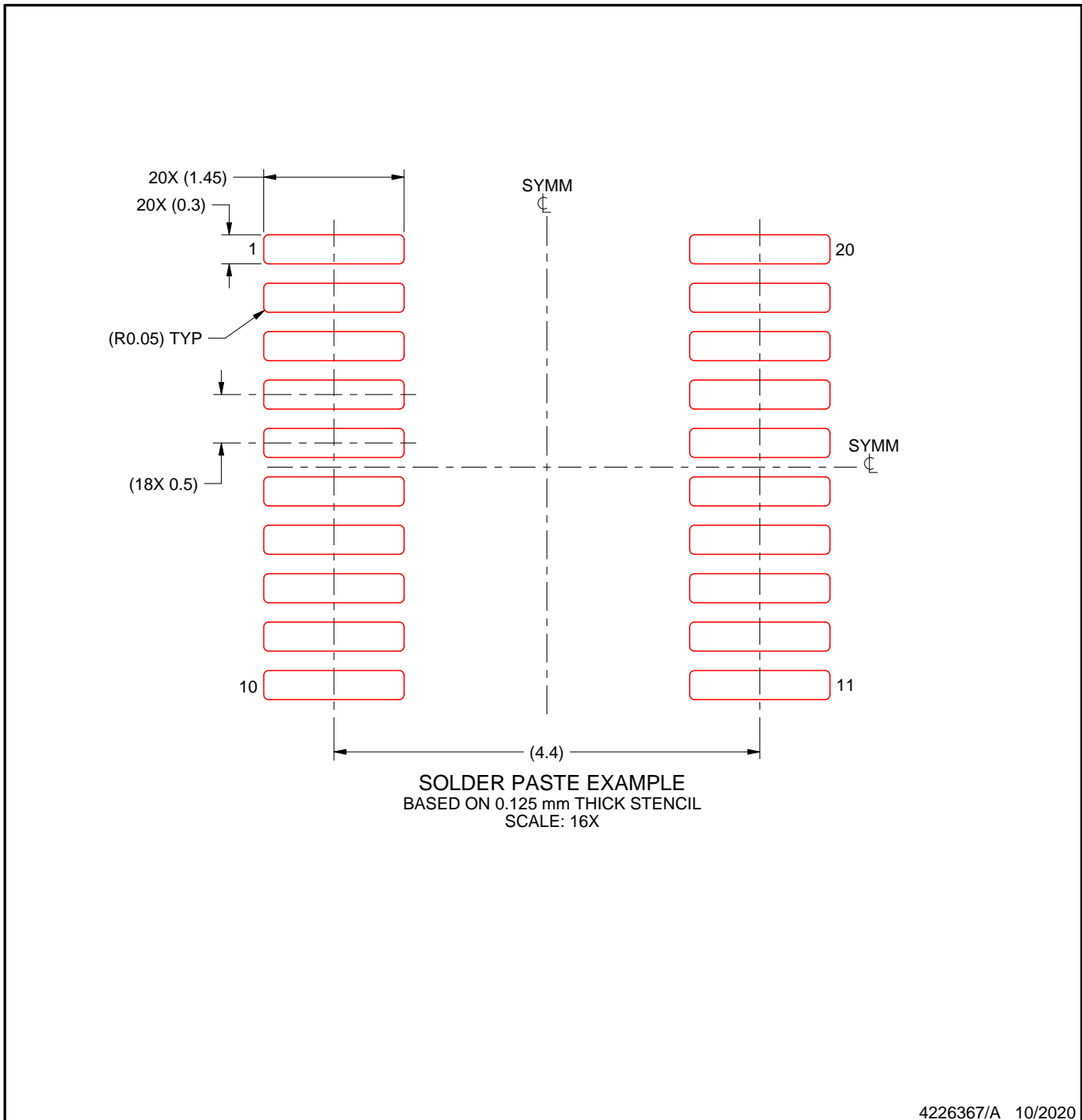

NOTES: (continued)

11. Laser cutting apertures with trapezoidal walls and rounded corners may offer better paste release. IPC-7525 may have alternate design recommendations.
12. Board assembly site may have different recommendations for stencil design.

DB0020A

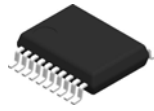

PACKAGE OUTLINE

SSOP - 2 mm max height

SMALL OUTLINE PACKAGE

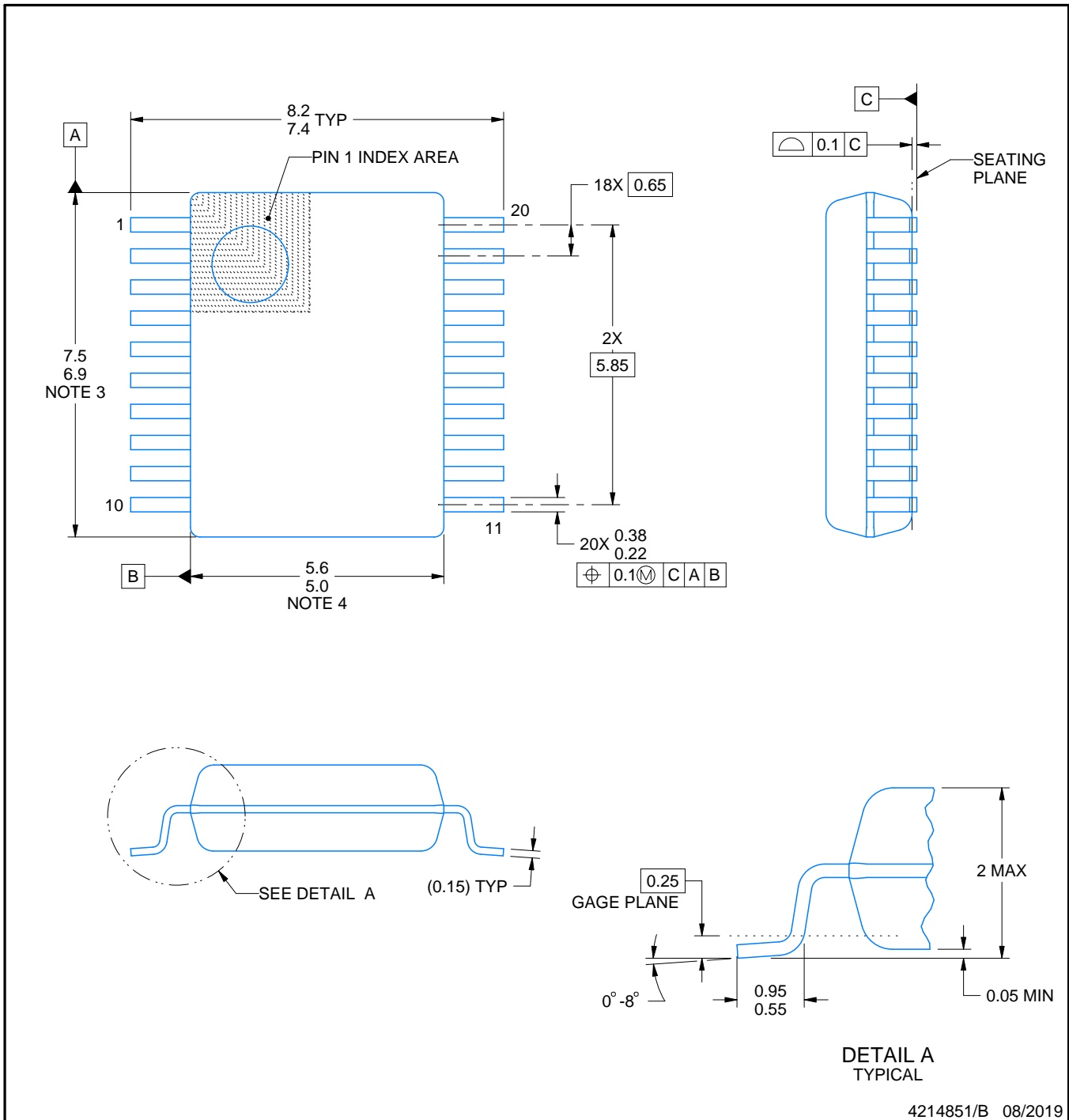

4214851/B 08/2019

NOTES:

1. All linear dimensions are in millimeters. Any dimensions in parenthesis are for reference only. Dimensioning and tolerancing per ASME Y14.5M.
2. This drawing is subject to change without notice.
3. This dimension does not include mold flash, protrusions, or gate burrs. Mold flash, protrusions, or gate burrs shall not exceed 0.15 mm per side.
4. This dimension does not include interlead flash. Interlead flash shall not exceed 0.25 mm per side.
5. Reference JEDEC registration MO-150.

EXAMPLE BOARD LAYOUT

DB0020A

SSOP - 2 mm max height

SMALL OUTLINE PACKAGE

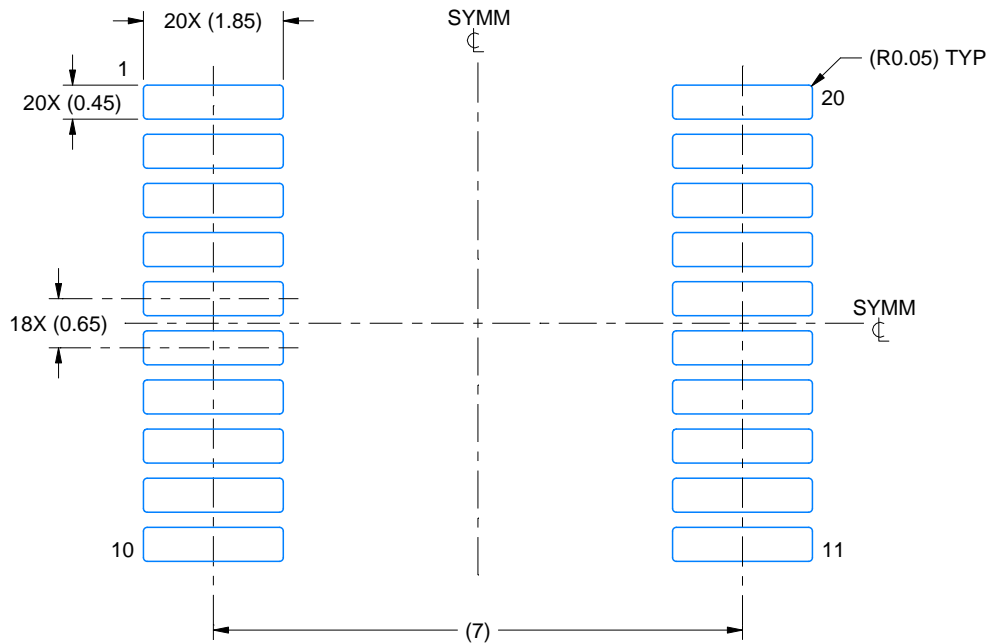

LAND PATTERN EXAMPLE
EXPOSED METAL SHOWN
SCALE: 10X

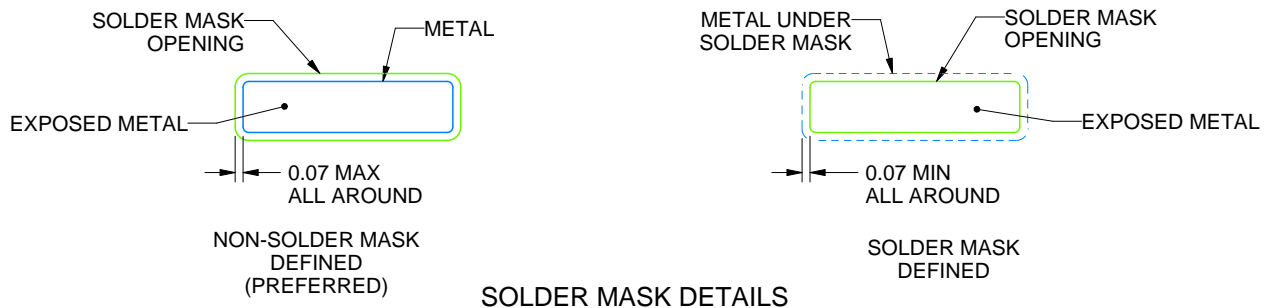

4214851/B 08/2019

NOTES: (continued)

- 6. Publication IPC-7351 may have alternate designs.
- 7. Solder mask tolerances between and around signal pads can vary based on board fabrication site.

EXAMPLE STENCIL DESIGN

DB0020A

SSOP - 2 mm max height

SMALL OUTLINE PACKAGE

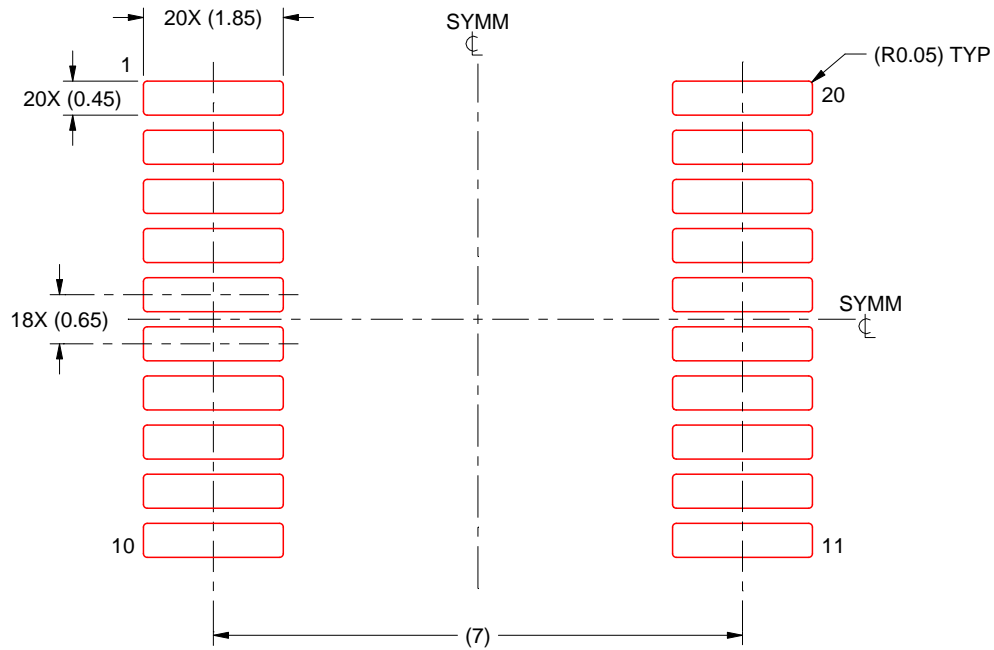

SOLDER PASTE EXAMPLE
BASED ON 0.125 mm THICK STENCIL
SCALE: 10X

4214851/B 08/2019

NOTES: (continued)

8. Laser cutting apertures with trapezoidal walls and rounded corners may offer better paste release. IPC-7525 may have alternate design recommendations.
9. Board assembly site may have different recommendations for stencil design.

MECHANICAL DATA

NS (R-PDSO-G)**

PLASTIC SMALL-OUTLINE PACKAGE

14-PINS SHOWN



- NOTES:
- A. All linear dimensions are in millimeters.
 - B. This drawing is subject to change without notice.
 - C. Body dimensions do not include mold flash or protrusion, not to exceed 0,15.

IMPORTANT NOTICE AND DISCLAIMER

TI PROVIDES TECHNICAL AND RELIABILITY DATA (INCLUDING DATASHEETS), DESIGN RESOURCES (INCLUDING REFERENCE DESIGNS), APPLICATION OR OTHER DESIGN ADVICE, WEB TOOLS, SAFETY INFORMATION, AND OTHER RESOURCES "AS IS" AND WITH ALL FAULTS, AND DISCLAIMS ALL WARRANTIES, EXPRESS AND IMPLIED, INCLUDING WITHOUT LIMITATION ANY IMPLIED WARRANTIES OF MERCHANTABILITY, FITNESS FOR A PARTICULAR PURPOSE OR NON-INFRINGEMENT OF THIRD PARTY INTELLECTUAL PROPERTY RIGHTS.

These resources are intended for skilled developers designing with TI products. You are solely responsible for (1) selecting the appropriate TI products for your application, (2) designing, validating and testing your application, and (3) ensuring your application meets applicable standards, and any other safety, security, regulatory or other requirements.

These resources are subject to change without notice. TI grants you permission to use these resources only for development of an application that uses the TI products described in the resource. Other reproduction and display of these resources is prohibited. No license is granted to any other TI intellectual property right or to any third party intellectual property right. TI disclaims responsibility for, and you fully indemnify TI and its representatives against any claims, damages, costs, losses, and liabilities arising out of your use of these resources.

TI's products are provided subject to [TI's Terms of Sale](#), [TI's General Quality Guidelines](#), or other applicable terms available either on ti.com or provided in conjunction with such TI products. TI's provision of these resources does not expand or otherwise alter TI's applicable warranties or warranty disclaimers for TI products. Unless TI explicitly designates a product as custom or customer-specified, TI products are standard, catalog, general purpose devices.

TI objects to and rejects any additional or different terms you may propose.

Copyright © 2026, Texas Instruments Incorporated

Last updated 10/2025