

HIGH-PERFORMANCE CURRENT-MODE PWM CONTROLLER

 Check for Samples: [TL2843B-Q1](#)

FEATURES

- Qualified for Automotive Applications
- Low Start-Up Current (<0.5 mA)
- Trimmed Oscillator Discharge Current
- Current Mode Operation to 500 kHz
- Automatic Feed-Forward Compensation
- Latching PWM for Cycle-by-Cycle Current Limiting
- Internally Trimmed Reference With Undervoltage Lockout
- High-Current Totem-Pole Output Undervoltage Lockout With Hysteresis
- Double-Pulse Suppression

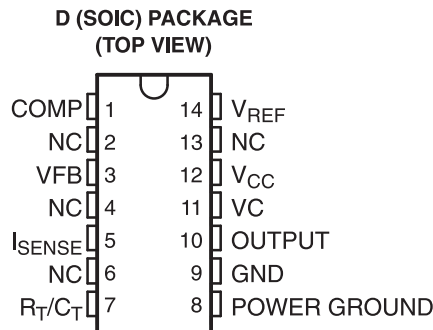

NC – No internal connection

DESCRIPTION

The TL284xB series of control integrated circuits provide the features that are necessary to implement off-line or dc-to-dc fixed-frequency current-mode control schemes, with a minimum number of external components. Internally implemented circuits include an undervoltage lockout (UVLO) and a precision reference that is trimmed for accuracy at the error amplifier input. Other internal circuits include logic to ensure latched operation, a pulse-width modulation (PWM) comparator that also provides current-limit control, and a totem-pole output stage designed to source or sink high-peak current. The output stage, suitable for driving N-channel MOSFETs, is low when it is in the off state.

The TL284xB series are pin compatible with the standard TL284x with the following improvements. The start-up current is specified to be 0.5 mA (max), while the oscillator discharge current is trimmed to 8.3 mA (typ). In addition, during undervoltage lockout conditions, the output has a maximum saturation voltage of 1.2 V while sinking 10 mA ($V_{CC} = 5$ V).

Major differences between members of these series are the UVLO thresholds and maximum duty-cycle ranges. Typical UVLO thresholds of 16 V (on) and 10 V (off) on the TL2842B and TL2844B devices make them ideally suited to off-line applications. The corresponding typical thresholds for the TL2843B and TL2845B devices are 8.4 V (on) and 7.6 V (off). The TL2842B and TL2843B devices can operate to duty cycles approaching 100%. A duty-cycle range of 0% to 50% is obtained by the TL2844B and TL2845B by the addition of an internal toggle flip-flop, which blanks the output off every other clock cycle. The TL284xB-series devices are characterized for operation from -40°C to 125°C .

Table 1. ORDERING INFORMATION⁽¹⁾

T_A	PACKAGE ⁽²⁾		ORDERABLE PART NUMBER	TOP-SIDE MARKING
-40°C to 125°C	SOIC – D	Reel of 2500	TL2842BQDRQ1	Product Preview
			TL2843BQDRQ1	TL2843BQ
			TL2844BQDRQ1	Product Preview
			TL2845BQDRQ1	Product Preview

(1) For the most current package and ordering information, see the Package Option Addendum at the end of this document, or see the TI web site at www.ti.com.

(2) Package drawings, thermal data, and symbolization are available at www.ti.com/packaging.



Please be aware that an important notice concerning availability, standard warranty, and use in critical applications of Texas Instruments semiconductor products and disclaimers thereto appears at the end of this data sheet.



These devices have limited built-in ESD protection. The leads should be shorted together or the device placed in conductive foam during storage or handling to prevent electrostatic damage to the MOS gates.

FUNCTIONAL BLOCK DIAGRAM

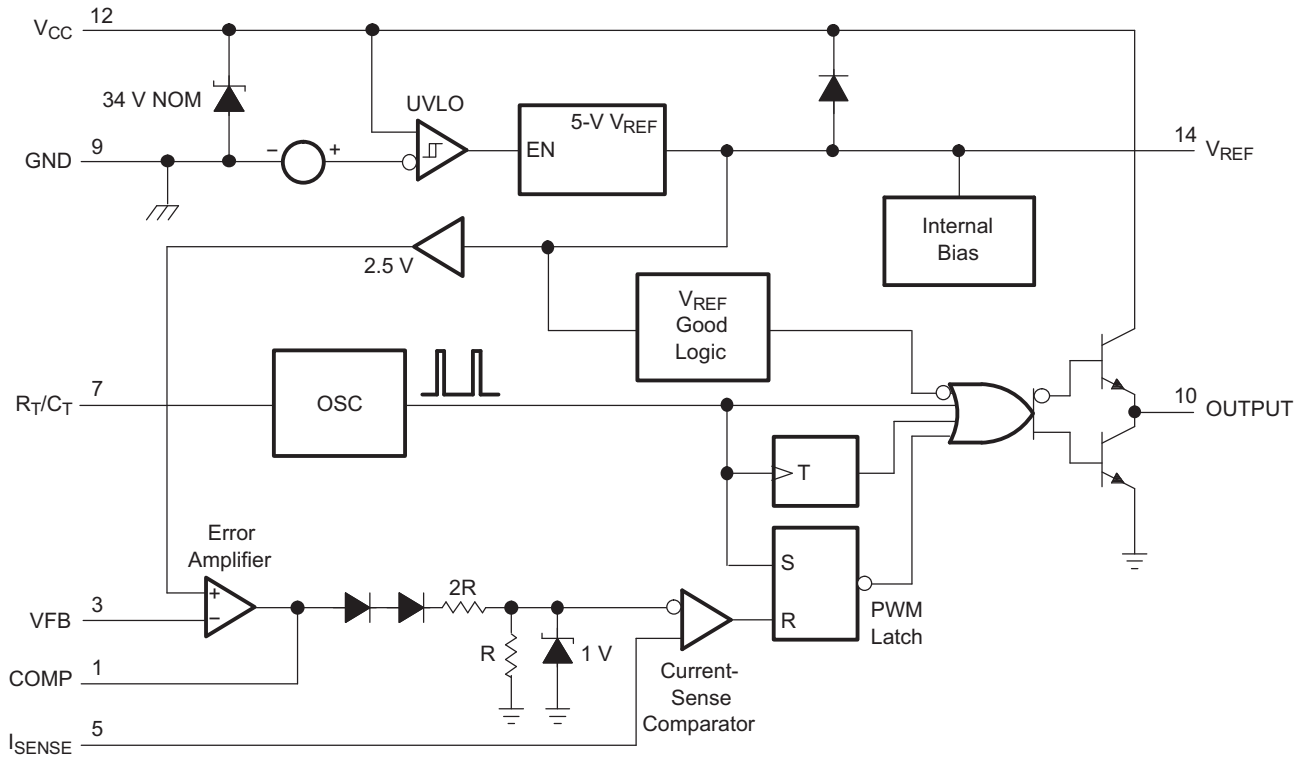

ABSOLUTE MAXIMUM RATINGS^{(1) (2)}

over operating free-air temperature range (unless otherwise noted)

		MIN	MAX	UNIT
V _{CC}	Supply voltage	Low impedance source		30
		I _{CC} < 30 mA		Self limiting
V _I	Analog input voltage range	VFB and I _{SENSE}	-0.3	6.3
I _{CC}	Supply current		30	mA
I _O	Output current		±1	A
I _{O(sink)}	Error amplifier output sink current		10	mA
θ _{JA}	Package thermal impedance ^{(3) (4)}	D package	97	°C/W
	Output energy	Capacitive load	5	μJ
T _J	Virtual junction temperature		150	°C
T _{stg}	Storage temperature range		-65	150

- (1) Stresses beyond those listed under "absolute maximum ratings" may cause permanent damage to the device. These are stress ratings only, and functional operation of the device at these or any other conditions beyond those indicated under "recommended operating conditions" is not implied. Exposure to absolute-maximum-rated conditions for extended periods may affect device reliability.
- (2) All voltages are with respect to the device GND terminal.
- (3) Maximum power dissipation is a function of T_{J(max)}, θ_{JA}, and T_A. The maximum allowable power dissipation at any allowable ambient temperature is P_D = (T_{J(max)} - T_A)/θ_{JA}. Operating at the absolute maximum T_J of 150°C can impact reliability.
- (4) The package thermal impedance is calculated in accordance with JESD 51-7.

RECOMMENDED OPERATING CONDITIONS

		MIN	NOM	MAX	UNIT
V _{CC}	Supply voltage	V _{CC}		30	V
		VC ⁽¹⁾		30	
V _I	Input voltage	R _T /C _T		0	V
		VFB and I _{SENSE}		0	
V _O	Output voltage	OUTPUT		0	V
		POWER GROUND ⁽¹⁾		-0.1	
I _{CC}	Supply current, externally limited			25	mA
I _O	Average output current			200	mA
I _{O(ref)}	Reference output current			-20	mA
f _{osc}	Oscillator frequency		100	500	kHz
T _A	Operating free-air temperature	-40		125	°C

- (1) The recommended voltages for VC and POWER GROUND apply only to the 14-pin D package.

REFERENCE SECTION ELECTRICAL CHARACTERISTICS

$V_{CC} = 15\text{ V}^{(1)}$, $R_T = 10\text{ k}\Omega$, $C_T = 3.3\text{ nF}$, over recommended operating free-air temperature range (unless otherwise specified)

PARAMETER	TEST CONDITIONS	TL284xB			UNIT
		MIN	TYP ⁽²⁾	MAX	
Output voltage	$I_O = 1\text{ mA}$, $T_J = 25^\circ\text{C}$	4.95	5	5.05	V
Line regulation	$V_{CC} = 12\text{ V to }25\text{ V}$		6	20	mV
Load regulation	$I_O = 1\text{ mA to }20\text{ mA}$		6	25	mV
Average temperature coefficient of output voltage			0.2	0.4	mV/°C
Output voltage, worst-case variation	$V_{CC} = 12\text{ V to }25\text{ V}$, $I_O = 1\text{ mA to }20\text{ mA}$	4.9		5.1	V
Output noise voltage	$f = 10\text{ Hz to }10\text{ kHz}$, $T_J = 25^\circ\text{C}$		50		μV
Output-voltage long-term drift	After 1000 h at $T_J = 25^\circ\text{C}$		5	25	mV
Short-circuit output current		-30	-100	-180	mA

(1) Adjust V_{CC} above the start threshold before setting it to 15 V.

(2) All typical values are at $T_J = 25^\circ\text{C}$.

OSCILLATOR SECTION⁽¹⁾ ELECTRICAL CHARACTERISTICS

$V_{CC} = 15\text{ V}^{(2)}$, $R_T = 10\text{ k}\Omega$, $C_T = 3.3\text{ nF}$, over recommended operating free-air temperature range (unless otherwise specified)

PARAMETER	TEST CONDITIONS	TL284xB			UNIT
		MIN	TYP ⁽³⁾	MAX	
Initial accuracy	$T_J = 25^\circ\text{C}$	49	52	55	kHz
	$T_A = T_{\text{low}} \text{ to } T_{\text{high}}$	48		56	
	$T_J = 25^\circ\text{C}$, $R_T = 6.2\text{ k}\Omega$, $C_T = 1\text{ nF}$	225	250	275	
Voltage stability	$V_{CC} = 12\text{ V to }25\text{ V}$		0.2	1	%
Temperature stability			5		%
Amplitude	Peak to peak		1.7		V
Discharge current ⁽⁴⁾	$T_J = 25^\circ\text{C}$, $R_T/C_T = 2\text{ V}$	7.8	8.3	8.8	mA
	$R_T/C_T = 2\text{ V}$	7.5		8.8	

(1) Output frequency equals oscillator frequency for the TL2842B and TL2843B. Output frequency is one-half the oscillator frequency for the TL2844B and TL2845B.

(2) Adjust V_{CC} above the start threshold before setting it to 15 V.

(3) All typical values are at $T_J = 25^\circ\text{C}$.

(4) Specified by design. Not production tested.

ERROR-AMPLIFIER SECTION ELECTRICAL CHARACTERISTICS

$V_{CC} = 15\text{ V}^{(1)}$, $R_T = 10\text{ k}\Omega$, $C_T = 3.3\text{ nF}$, over recommended operating free-air temperature range (unless otherwise specified)

PARAMETER	TEST CONDITIONS	TL284xB			UNIT
		MIN	TYP ⁽²⁾	MAX	
Feedback input voltage	COMP = 2.5 V	2.45	2.5	2.55	V
Input bias current			-0.3	-1	μA
Open-loop voltage amplification	$V_O = 2\text{ V to }4\text{ V}$	65	90		dB
Gain-bandwidth product		0.7	1		MHz
Supply-voltage rejection ratio	$V_{CC} = 12\text{ V to }25\text{ V}$	60	70		dB
Output sink current	VFB = 2.7 V, COMP = 1.1 V	2	6		mA
Output source current	VFB = 2.3 V, COMP = 5 V	-0.5	-0.8		mA
High-level output voltage	VFB = 2.3 V, $R_L = 15\text{ k}\Omega$ to GND	5	6		V
Low-level output voltage	VFB = 2.7 V, $R_L = 15\text{ k}\Omega$ to GND		0.7	1.1	V

(1) Adjust V_{CC} above the start threshold before setting it to 15 V.

(2) All typical values are at $T_J = 25^\circ\text{C}$.

CURRENT-SENSE SECTION ELECTRICAL CHARACTERISTICS

$V_{CC} = 15\text{ V}^{(1)}$, $R_T = 10\text{ k}\Omega$, $C_T = 3.3\text{ nF}$, over recommended operating free-air temperature range (unless otherwise specified)

PARAMETER	TEST CONDITIONS	TL284xB			UNIT
		MIN	TYP ⁽²⁾	MAX	
Voltage amplification ^{(3) (4)}		2.85	3	3.15	V/V
Current-sense comparator threshold ⁽³⁾	COMP = 5 V	0.9	1	1.1	V
Supply-voltage rejection ratio ⁽³⁾	$V_{CC} = 12\text{ V to }25\text{ V}$		70		dB
Input bias current			-2	-10	μA
Delay time to output ⁽⁵⁾	VFB = 0 V to 2 V		150	300	ns

(1) Adjust V_{CC} above the start threshold before setting it to 15 V.

(2) All typical values are at $T_J = 25^\circ\text{C}$.

(3) Measured at the trip point of the latch, with VFB at 0 V.

(4) Measured between I_{SENSE} and COMP, with the input changing from 0 V to 0.8 V.

(5) Specified by design. Not production tested.

Output Section Electrical Characteristics

$V_{CC} = 15\text{ V}^{(1)}$, $R_T = 10\text{ k}\Omega$, $C_T = 3.3\text{ nF}$, over recommended operating free-air temperature range (unless otherwise specified)

PARAMETER	TEST CONDITIONS	TL284xB			UNIT
		MIN	TYP ⁽²⁾	MAX	
High-level output voltage	$I_{OH} = -20\text{ mA}$	13	13.5		V
	$I_{OH} = -200\text{ mA}$	12	13.5		
Low-level output voltage	$I_{OL} = 20\text{ mA}$		0.1	0.4	V
	$I_{OL} = 200\text{ mA}$		1.5	2.2	
Rise time ⁽³⁾	$C_L = 1\text{ nF}$, $T_J = 25^\circ\text{C}$		50	150	ns
Fall time ⁽³⁾	$C_L = 1\text{ nF}$, $T_J = 25^\circ\text{C}$		50	150	ns
UVLO saturation ⁽³⁾	$V_{CC} = 5\text{ V}$, $I_{OL} = 1\text{ mA}$		0.7	1.2	V

(1) Adjust V_{CC} above the start threshold before setting it to 15 V.

(2) All typical values are at $T_J = 25^\circ\text{C}$.

(3) Specified by design. Not production tested.

UNDERVOLTAGE-LOCKOUT SECTION ELECTRICAL CHARACTERISTICS

$V_{CC} = 15\text{ V}^{(1)}$, $R_T = 10\text{ k}\Omega$, $C_T = 3.3\text{ nF}$, over recommended operating free-air temperature range (unless otherwise specified)

PARAMETER	TEST CONDITIONS	TL284xB			UNIT
		MIN	TYP ⁽²⁾	MAX	
Start threshold voltage		7.8	8.4	9	V
Minimum operating voltage after start-up		7	7.6	8.2	V

(1) Adjust V_{CC} above the start threshold before setting it to 15 V.

(2) All typical values are at $T_J = 25^\circ\text{C}$.

PULSE-WIDTH MODULATOR SECTION ELECTRICAL CHARACTERISTICS

$V_{CC} = 15\text{ V}^{(1)}$, $R_T = 10\text{ k}\Omega$, $C_T = 3.3\text{ nF}$, over recommended operating free-air temperature range (unless otherwise specified)

PARAMETER	TEST CONDITIONS	TL284xB			UNIT
		MIN	TYP ⁽²⁾	MAX	
Maximum duty cycle ⁽³⁾		94	96	100	%
Minimum duty cycle				0	%

(1) Adjust V_{CC} above the start threshold before setting it to 15 V.

(2) All typical values are at $T_J = 25^\circ\text{C}$.

(3) Specified by design. Not production tested.

SUPPLY VOLTAGE ELECTRICAL CHARACTERISTICS

$V_{CC} = 15\text{ V}^{(1)}$, $R_T = 10\text{ k}\Omega$, $C_T = 3.3\text{ nF}$, over recommended operating free-air temperature range (unless otherwise specified)

PARAMETER	TEST CONDITIONS	TL284xB			UNIT
		MIN	TYP ⁽²⁾	MAX	
Start-up current			0.3	0.5	mA
Operating supply current	VFB and I_{SENSE} at 0 V		11	17	mA
Limiting voltage	$I_{CC} = 25\text{ mA}$	30	34		V

(1) Adjust V_{CC} above the start threshold before setting it to 15 V.

(2) All typical values are at $T_J = 25^\circ\text{C}$.

TYPICAL CHARACTERISTICS

SUPPLY CURRENT
vs
SUPPLY VOLTAGE

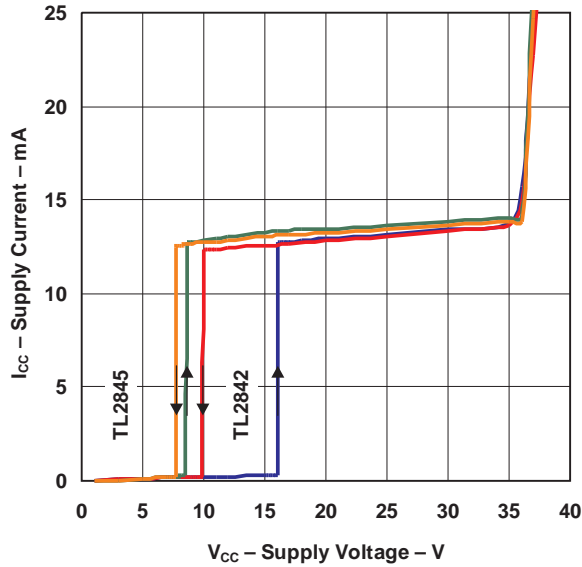

ERROR AMPLIFIER OPEN-LOOP
GAIN AND PHASE
vs
FREQUENCY

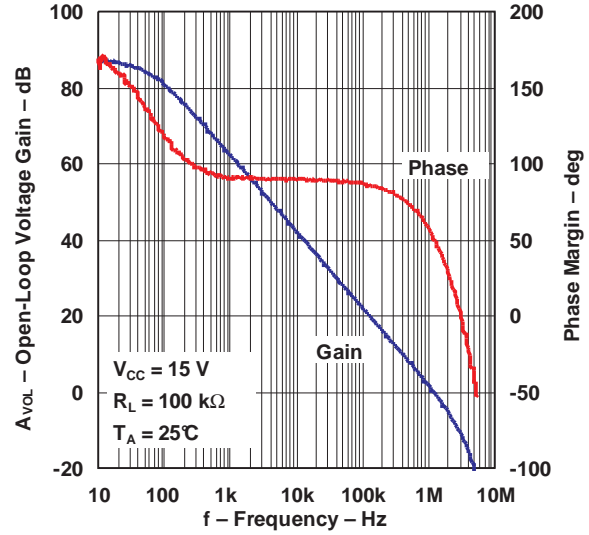

CURRENT-SENSE INPUT THRESHOLD
vs
ERROR AMPLIFIER OUTPUT VOLTAGE

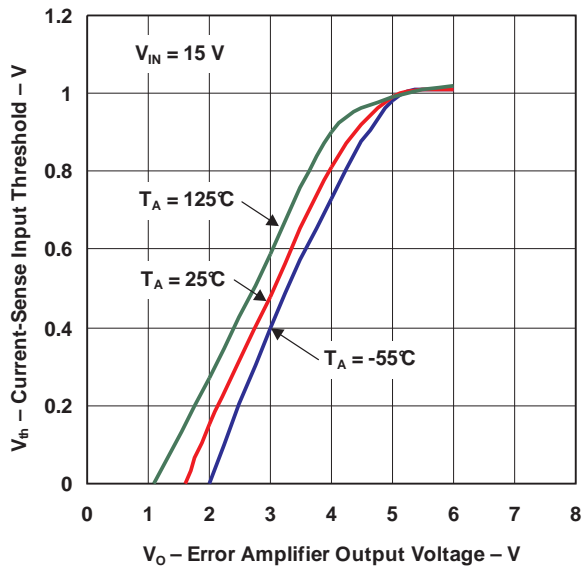

OSCILLATOR DISCHARGE CURRENT
vs
TEMPERATURE

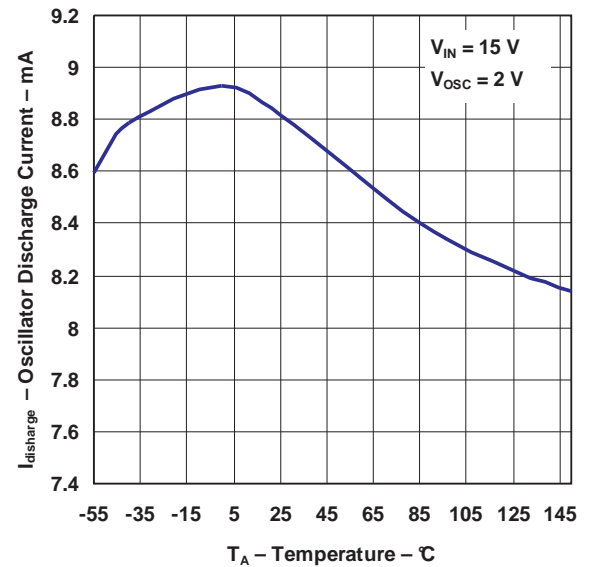

TYPICAL CHARACTERISTICS (continued)

**REFERENCE VOLTAGE
vs
SOURCE CURRENT**



**REFERENCE VOLTAGE
vs
TEMPERATURE**

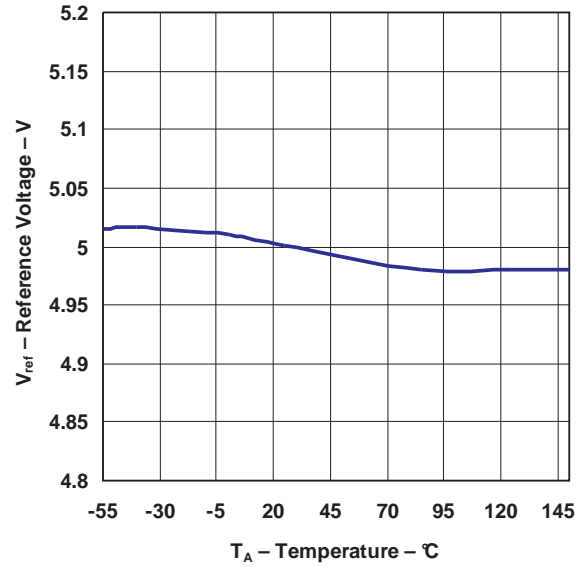

**REFERENCE SHORT-CIRCUIT CURRENT
vs
TEMPERATURE**

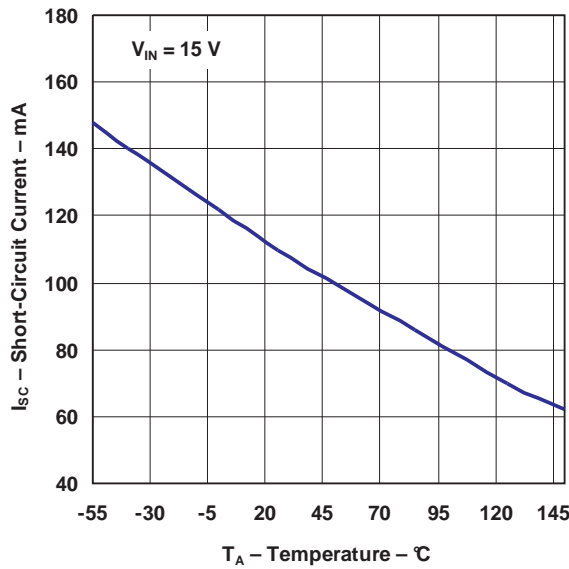

**OUTPUT SATURATION VOLTAGE
vs
LOAD CURRENT**

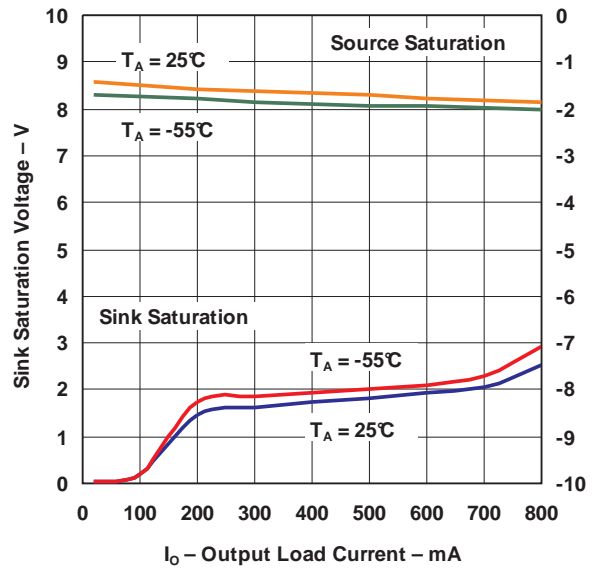

TYPICAL CHARACTERISTICS (continued)
MAXIMUM OUTPUT DUTY CYCLE
vs
TIMING RESISTOR

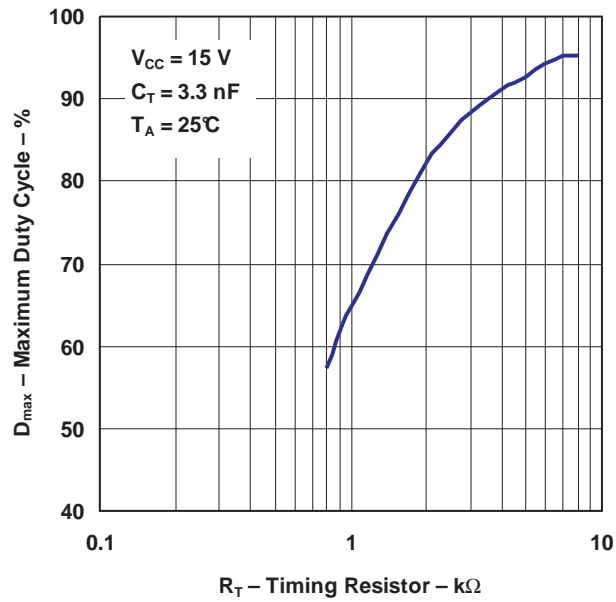

APPLICATION INFORMATION

The error-amplifier configuration circuit is shown in Figure 1.

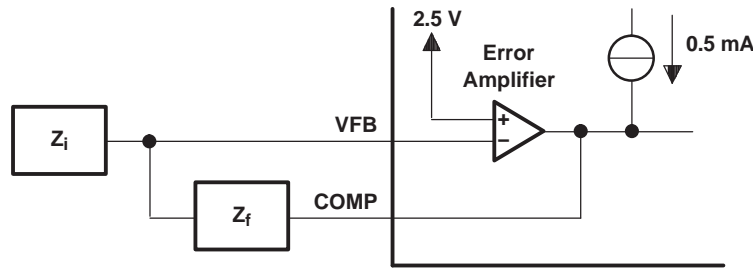

- A. Error amplifier can source or sink up to 0.5 mA.

Figure 1. Error-Amplifier Configuration

The current-sense circuit is shown in Figure 2.

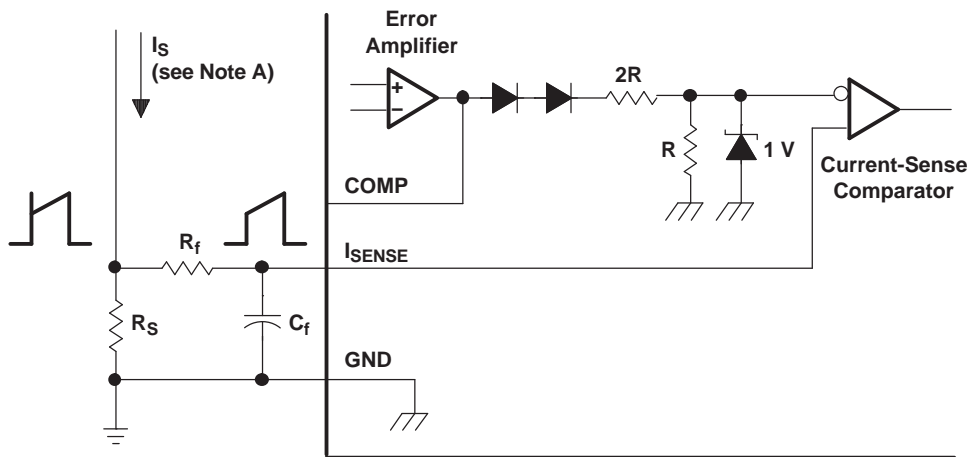

- A. Peak current (I_S) is determined by the formula: $I_{S(max)} = 1 V/R_S$
- B. A small RC filter formed by resistor R_f and capacitor C_f may be required to suppress switch transients.

Figure 2. Current-Sense Circuit

The oscillator frequency is set using the circuit shown in Figure 3. The frequency is calculated as:

$$f = 1 / R_T C_T$$

For $R_T > 5 \text{ k}\Omega$:

$$f \approx 1.72 / R_T C_T$$

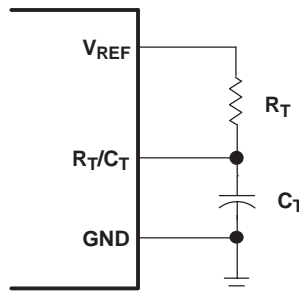
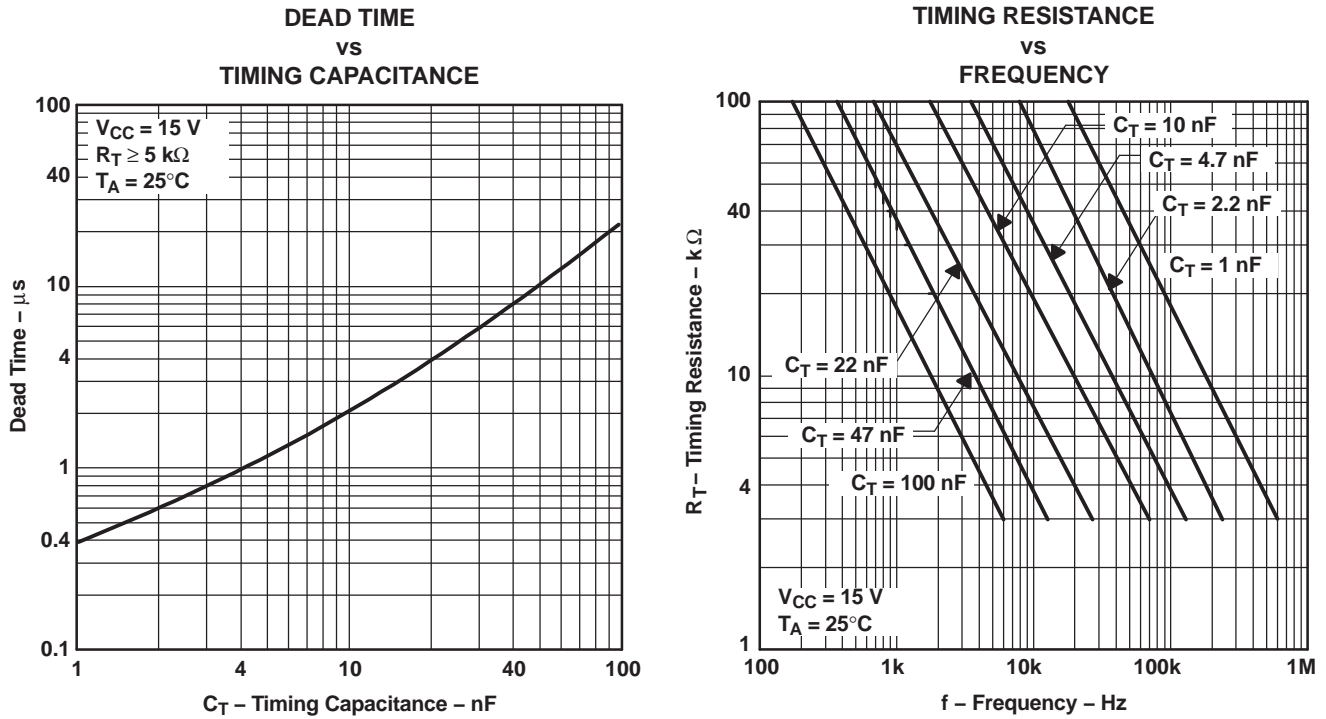

Figure 3. Oscillator Section



Open-Loop Laboratory Test Fixture

In the open-loop laboratory test fixture (see Figure 4), high peak currents associated with loads necessitate careful grounding techniques. Timing and bypass capacitors should be connected close to the GND terminal in a single-point ground. The transistor and 5-k Ω potentiometer sample the oscillator waveform and apply an adjustable ramp to the I_{SENSE} terminal.

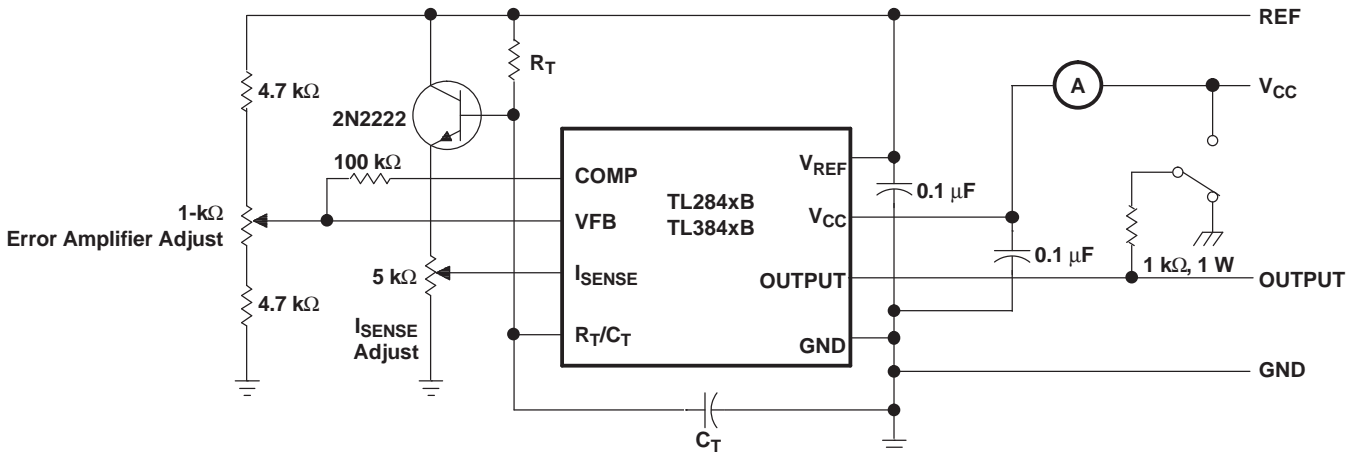

Figure 4. Open-Loop Laboratory Test Fixture

Shutdown Technique

The PWM controller (see [Figure 5](#)) can be shut down by two methods: either raise the voltage at I_{SENSE} above 1 V or pull the COMP terminal below a voltage two diode drops above ground. Either method causes the output of the PWM comparator to be high (see the *Functional Block Diagram*). The PWM latch is reset dominant so that the output remains low until the next clock cycle after the shutdown condition at the COMP or I_{SENSE} terminal is removed. In one example, an externally latched shutdown can be accomplished by adding an SCR that resets by cycling V_{CC} below the lower UVLO threshold. At this point, the reference turns off, allowing the SCR to reset.

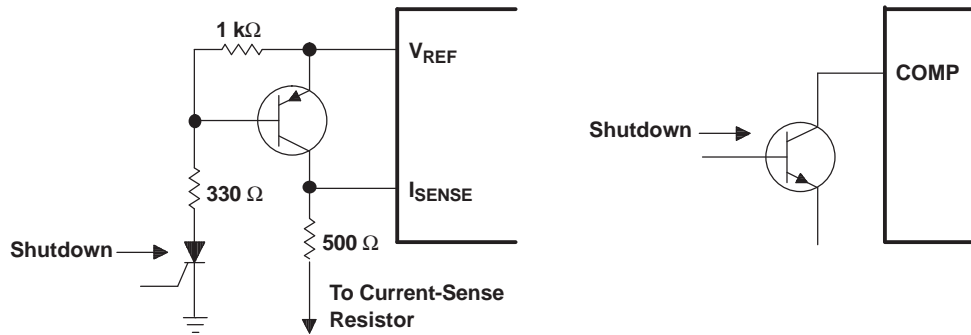

Figure 5. Shutdown Techniques

A fraction of the oscillator ramp can be summed resistively with the current-sense signal to provide slope compensation for converters requiring duty cycles over 50% (see [Figure 6](#)). Note that capacitor C forms a filter with R2 to suppress the leading-edge switch spikes.

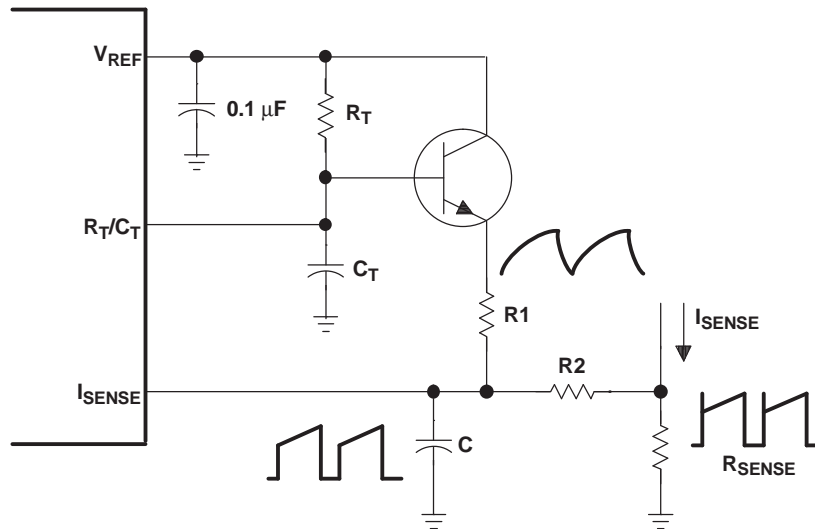

Figure 6. Slope Compensation

REVISION HISTORY

Changes from Original (July 2012) to Revision A	Page
• Changed the pinout from an 8-pin to 14-pin D package	1
• Changed the Functional Block diagram pin numbers for the 14-pin D package	2

PACKAGING INFORMATION

Orderable part number	Status (1)	Material type (2)	Package Pins	Package qty Carrier	RoHS (3)	Lead finish/ Ball material (4)	MSL rating/ Peak reflow (5)	Op temp (°C)	Part marking (6)
TL2843BQDRQ1	NRND	Production	SOIC (D) 14	2500 LARGE T&R	Yes	NIPDAU	Level-1-260C-UNLIM	-40 to 125	TL2843BQ
TL2843BQDRQ1.A	NRND	Production	SOIC (D) 14	2500 LARGE T&R	Yes	NIPDAU	Level-1-260C-UNLIM	-40 to 125	TL2843BQ

(1) **Status:** For more details on status, see our [product life cycle](#).

(2) **Material type:** When designated, preproduction parts are prototypes/experimental devices, and are not yet approved or released for full production. Testing and final process, including without limitation quality assurance, reliability performance testing, and/or process qualification, may not yet be complete, and this item is subject to further changes or possible discontinuation. If available for ordering, purchases will be subject to an additional waiver at checkout, and are intended for early internal evaluation purposes only. These items are sold without warranties of any kind.

(3) **RoHS values:** Yes, No, RoHS Exempt. See the [TI RoHS Statement](#) for additional information and value definition.

(4) **Lead finish/Ball material:** Parts may have multiple material finish options. Finish options are separated by a vertical ruled line. Lead finish/Ball material values may wrap to two lines if the finish value exceeds the maximum column width.

(5) **MSL rating/Peak reflow:** The moisture sensitivity level ratings and peak solder (reflow) temperatures. In the event that a part has multiple moisture sensitivity ratings, only the lowest level per JEDEC standards is shown. Refer to the shipping label for the actual reflow temperature that will be used to mount the part to the printed circuit board.

(6) **Part marking:** There may be an additional marking, which relates to the logo, the lot trace code information, or the environmental category of the part.

Multiple part markings will be inside parentheses. Only one part marking contained in parentheses and separated by a "~" will appear on a part. If a line is indented then it is a continuation of the previous line and the two combined represent the entire part marking for that device.

Important Information and Disclaimer:The information provided on this page represents TI's knowledge and belief as of the date that it is provided. TI bases its knowledge and belief on information provided by third parties, and makes no representation or warranty as to the accuracy of such information. Efforts are underway to better integrate information from third parties. TI has taken and continues to take reasonable steps to provide representative and accurate information but may not have conducted destructive testing or chemical analysis on incoming materials and chemicals. TI and TI suppliers consider certain information to be proprietary, and thus CAS numbers and other limited information may not be available for release.

In no event shall TI's liability arising out of such information exceed the total purchase price of the TI part(s) at issue in this document sold by TI to Customer on an annual basis.

OTHER QUALIFIED VERSIONS OF TL2843B-Q1 :

- Catalog : [TL2843B](#)

NOTE: Qualified Version Definitions:

- Catalog - TI's standard catalog product

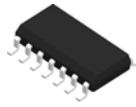

D0014A

PACKAGE OUTLINE

SOIC - 1.75 mm max height

SMALL OUTLINE INTEGRATED CIRCUIT



4220718/A 09/2016

NOTES:

1. All linear dimensions are in millimeters. Dimensions in parenthesis are for reference only. Dimensioning and tolerancing per ASME Y14.5M.
2. This drawing is subject to change without notice.
3. This dimension does not include mold flash, protrusions, or gate burrs. Mold flash, protrusions, or gate burrs shall not exceed 0.15 mm, per side.
4. This dimension does not include interlead flash. Interlead flash shall not exceed 0.43 mm, per side.
5. Reference JEDEC registration MS-012, variation AB.

EXAMPLE BOARD LAYOUT

D0014A

SOIC - 1.75 mm max height

SMALL OUTLINE INTEGRATED CIRCUIT



LAND PATTERN EXAMPLE
SCALE:8X



SOLDER MASK DETAILS

4220718/A 09/2016

NOTES: (continued)

- 6. Publication IPC-7351 may have alternate designs.
- 7. Solder mask tolerances between and around signal pads can vary based on board fabrication site.

EXAMPLE STENCIL DESIGN

D0014A

SOIC - 1.75 mm max height

SMALL OUTLINE INTEGRATED CIRCUIT



SOLDER PASTE EXAMPLE
BASED ON 0.125 mm THICK STENCIL
SCALE:8X

4220718/A 09/2016

NOTES: (continued)

8. Laser cutting apertures with trapezoidal walls and rounded corners may offer better paste release. IPC-7525 may have alternate design recommendations.
9. Board assembly site may have different recommendations for stencil design.

IMPORTANT NOTICE AND DISCLAIMER

TI PROVIDES TECHNICAL AND RELIABILITY DATA (INCLUDING DATASHEETS), DESIGN RESOURCES (INCLUDING REFERENCE DESIGNS), APPLICATION OR OTHER DESIGN ADVICE, WEB TOOLS, SAFETY INFORMATION, AND OTHER RESOURCES "AS IS" AND WITH ALL FAULTS, AND DISCLAIMS ALL WARRANTIES, EXPRESS AND IMPLIED, INCLUDING WITHOUT LIMITATION ANY IMPLIED WARRANTIES OF MERCHANTABILITY, FITNESS FOR A PARTICULAR PURPOSE OR NON-INFRINGEMENT OF THIRD PARTY INTELLECTUAL PROPERTY RIGHTS.

These resources are intended for skilled developers designing with TI products. You are solely responsible for (1) selecting the appropriate TI products for your application, (2) designing, validating and testing your application, and (3) ensuring your application meets applicable standards, and any other safety, security, regulatory or other requirements.

These resources are subject to change without notice. TI grants you permission to use these resources only for development of an application that uses the TI products described in the resource. Other reproduction and display of these resources is prohibited. No license is granted to any other TI intellectual property right or to any third party intellectual property right. TI disclaims responsibility for, and you fully indemnify TI and its representatives against any claims, damages, costs, losses, and liabilities arising out of your use of these resources.

TI's products are provided subject to [TI's Terms of Sale](#), [TI's General Quality Guidelines](#), or other applicable terms available either on [ti.com](#) or provided in conjunction with such TI products. TI's provision of these resources does not expand or otherwise alter TI's applicable warranties or warranty disclaimers for TI products. Unless TI explicitly designates a product as custom or customer-specified, TI products are standard, catalog, general purpose devices.

TI objects to and rejects any additional or different terms you may propose.

Copyright © 2026, Texas Instruments Incorporated

Last updated 10/2025