

# TLV854x 500-nA, RRIO, Nanopower Operational Amplifiers for Cost-Optimized Systems

## 1 Features

- For Cost-Optimized Systems
- Nanopower Supply Current: 500 nA per Channel
- Offset Voltage: 3.1 mV (maximum)
- $TcVos$ : 0.8  $\mu V/^\circ C$
- Gain Bandwidth: 8 kHz
- Unity-Gain Stable
- Low Input-Bias Current: 100 fA
- Wide Supply Range: 1.7 V to 3.6 V
- Rail-to-Rail Input and Output (RRIO)
- Temperature Range  $-40^\circ C$  to  $+125^\circ C$
- Industry Standard Package
  - Quad in 14-pin TSSOP and SOIC
  - Dual in 8-pin SOIC
  - Single in 5-pin SOT-23
- Leadless Package
  - Dual in 8-Pin X2QFN

## 2 Applications

- Motion Detectors Using PIR Sensors [SNA301](#)
- Motion Detectors Using Microwave Sensors
- Gas Detectors
- Ionization Smoke Alarms
- Thermostats
- Remote Sensors, IoT (Internet of Things)
- Active RFID Readers and Tags
- Portable Medical Equipment
- Glucose Monitoring

## 3 Description

The TLV854x ultra-low-power operational amplifiers (op amps) are intended for cost-optimized sensing applications in wireless and low-power wired equipment. The TLV854x family of op amps minimize power consumption in equipment such as motion detecting security systems (like microwave and PIR motion sensing) where operational battery life is critical. They also have a carefully designed CMOS input stage, enabling very low, femto-ampere bias currents, thereby reducing  $I_{BIAS}$  and  $I_{OS}$  errors that would otherwise impact sensitive applications. Examples of these include transimpedance amplifier (TIA) configurations with megaohm feedback resistors, and high source impedance sensing applications. Additionally, built-in EMI protection reduces sensitivity to unwanted RF signals from sources such as mobile phones, WiFi, radio transmitters and tab readers.

### Device Information<sup>(1)</sup>

PART NUMBER	PACKAGE	BODY SIZE
TLV8544	TSSOP (14)	5.00 mm x 4.40 mm
	SOIC (14)	8.65 mm x 3.91 mm
TLV8542	SOIC (8)	4.9 mm x 3.90 mm
	X2QFN (8)	1.50 mm x 1.50 mm
TLV8541	SOT-23 (5)	2.90 mm x 1.60 mm

(1) For all available packages, see the orderable addendum at the end of the data sheet.

### Nanopower Amplifiers Family

FAMILY	CHANNEL COUNT	$I_Q$ PER CHANNEL	$V_{OS}$ (MAXIMUM)	$V_{SUPPLY}$
TLV854x	1, 2, 4	500 nA	3.1 mV	1.7 to 3.6 V
TLV880x	1, 2	320 nA	4.5 mV	1.7 to 5.5 V
LPV81x	1, 2	425 nA	0.3 mV	1.6 to 5.5 V

### Low Power PIR Motion Detector

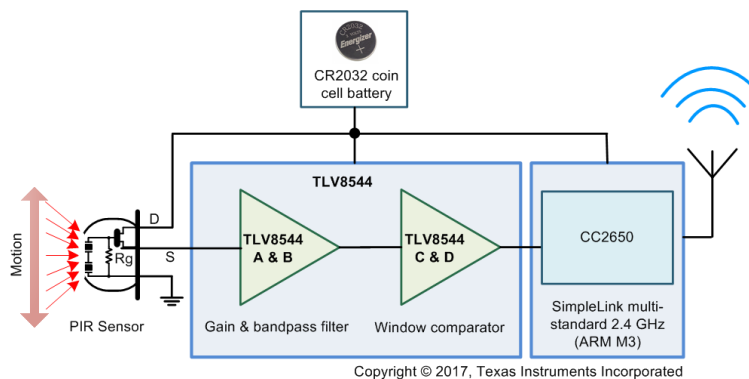
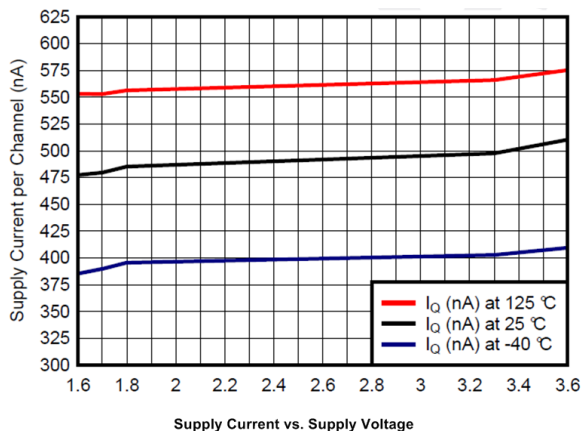

## Table of Contents

<b>1 Features</b> .....	<b>1</b>	9.1 Application Information.....	<b>14</b>
<b>2 Applications</b> .....	<b>1</b>	9.2 Typical Application: Battery-Powered Wireless PIR Motion Detectors .....	<b>15</b>
<b>3 Description</b> .....	<b>1</b>	9.3 Typical Application: 60-Hz Twin T Notch Filter .....	<b>19</b>
<b>4 Revision History</b> .....	<b>2</b>	9.4 Dos and Don'ts .....	<b>20</b>
<b>5 Description (continued)</b> .....	<b>2</b>	<b>10 Power Supply Recommendations</b> .....	<b>20</b>
<b>6 Pin Configuration and Functions</b> .....	<b>3</b>	<b>11 Layout</b> .....	<b>21</b>
<b>7 Specifications</b> .....	<b>5</b>	11.1 Layout Guidelines .....	<b>21</b>
7.1 Absolute Maximum Ratings .....	<b>5</b>	11.2 Layout Example .....	<b>21</b>
7.2 ESD Ratings.....	<b>5</b>	<b>12 Device and Documentation Support</b> .....	<b>22</b>
7.3 Recommended Operating Conditions.....	<b>5</b>	12.1 Device Support .....	<b>22</b>
7.4 Thermal Information .....	<b>5</b>	12.2 Documentation Support .....	<b>22</b>
7.5 Electrical Characteristics.....	<b>6</b>	12.3 Related Links .....	<b>22</b>
7.6 Typical Characteristics.....	<b>7</b>	12.4 Receiving Notification of Documentation Updates .....	<b>22</b>
<b>8 Detailed Description</b> .....	<b>12</b>	12.5 Community Resources.....	<b>22</b>
8.1 Overview .....	<b>12</b>	12.6 Trademarks .....	<b>23</b>
8.2 Functional Block Diagram .....	<b>12</b>	12.7 Electrostatic Discharge Caution.....	<b>23</b>
8.3 Feature Description.....	<b>12</b>	12.8 Glossary .....	<b>23</b>
8.4 Device Functional Modes.....	<b>12</b>	<b>13 Mechanical, Packaging, and Orderable Information</b> .....	<b>23</b>
<b>9 Application and Implementation</b> .....	<b>14</b>		

## 4 Revision History

<b>Changes from Revision D (November 2017) to Revision E</b>	<b>Page</b>
• Released TLV8542 X2QFN package as production data .....	<b>1</b>
• Released TLV8544 SOIC package as production data .....	<b>1</b>

<b>Changes from Revision C (October 2017) to Revision D</b>	<b>Page</b>
• Production Data Release of TLV8541 .....	<b>1</b>
• Added 8-pin X2QFN package for the TLV8542.....	<b>1</b>

<b>Changes from Revision B (June 2017) to Revision C</b>	<b>Page</b>
• Changed TLV8542 dual datasheet to production data.....	<b>1</b>

<b>Changes from Revision A (March 2017) to Revision B</b>	<b>Page</b>
• Added Advance Information TLV8542 to the TLV8544 Data Sheet .....	<b>1</b>

<b>Changes from Original (December 2016) to Revision A</b>	<b>Page</b>
• Changed Product Preview to Production Data release. ....	<b>1</b>

## 5 Description (continued)

The TLV854x op amps operate with a single supply voltage down to 1.7 V supply, providing continuous performance in low battery situations over the extended temperature range of  $-40^{\circ}\text{C}$  to  $+125^{\circ}\text{C}$ . All versions are specified for operation from  $-40^{\circ}\text{C}$  to  $125^{\circ}\text{C}$ . The TLV8541 (single version) is available in the 5-pin SOT-23 while the TLV8542 (dual version) is available in the 8-pin SOIC package. The 4-channel TLV8544 (quad version) is available in the industry standard 14-pin TSSOP package.

## 6 Pin Configuration and Functions

**TLV8541 DBV Package**  
5-Pin SOT-23  
Top View

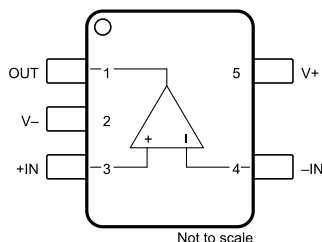

**Pin Functions: TLV8541 DBV**

PIN		I/O	DESCRIPTION
NUMBER	NAME		
1	OUT	O	Output
2	V-	P	Negative (lowest) power supply
3	+IN	I	Non-Inverting Input
4	-IN	I	Inverting Input
5	V+	P	Positive (highest) power supply

**TLV8542 D Package**  
8-Pin SOIC  
Top View

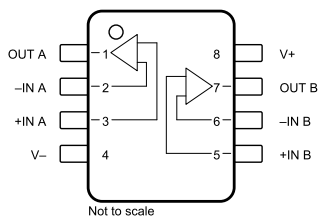

**TLV8542 RUG Package**  
8-Pin X2QFN  
Top View

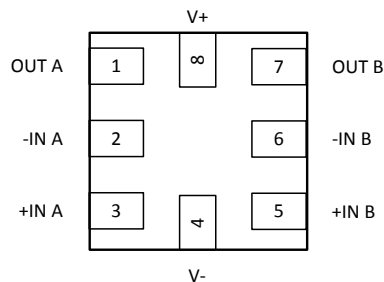

**Pin Functions: TLV8542 D & RUG**

PIN		I/O	DESCRIPTION
NUMBER	NAME		
1	OUT A	O	Channel A Output
2	-IN A	I	Channel A Inverting Input
3	+IN A	I	Channel A Non-Inverting Input
4	V-	P	Negative (lowest) power supply
5	+IN B	I	Channel B Non-Inverting Input
6	-IN B	I	Channel B Inverting Input
7	OUT B	O	Channel B Output
8	V+	P	Positive (highest) power supply

**TLV8544 PW and D Package**  
**14-Pin TSSOP and SOIC**  
**Top View**



**Pin Functions: TLV8544 PW & D**

PIN		I/O	DESCRIPTION
NUMBER	NAME		
1	OUTA	O	Channel A output
2	-INA	I	Channel A inverting input
3	+INA	I	Channel A non-inverting input
4	V+	P	Positive (highest) power supply
5	+INB	I	Channel B non-inverting input
6	-INB	I	Channel B inverting input
7	OUTB	O	Channel B output
8	OUTC	O	Channel C output
9	-INC	I	Channel C inverting input
10	+INC	I	Channel C non-inverting input
11	V-	P	Negative (lowest) power supply
12	+IND	I	Channel D non-inverting input
13	-IND	I	Channel D inverting input
14	OUTD	O	Channel D output

## 7 Specifications

### 7.1 Absolute Maximum Ratings

Over operating free-air temperature range (unless otherwise noted) <sup>(1)</sup> <sup>(2)</sup> <sup>(3)</sup>

		MIN	MAX	UNIT
Supply voltage, $V_s = (V+) - (V-)$		-0.3	4	V
Input pins	Voltage			
	Common mode	(V-) - 0.3	(V+) + 0.3	V
	Differential	(V-) - 0.3	(V+) + 0.3	V
Input pins	Current	-10	10	mA
Output short current <sup>(4)</sup>		Continuous	Continuous	
Operating ambient temperature		-40	125	°C
Storage temperature, $T_{stg}$		-65	150	°C
Junction temperature			150	°C

- Stresses beyond those listed under *Absolute Maximum Ratings* may cause permanent damage to the device. These are stress ratings only, which do not imply functional operation of the device at these or any other conditions beyond those indicated under *Recommended Operating Conditions*. Exposure to absolute-maximum-rated conditions for extended periods may affect device reliability.
- Input terminals are diode-clamped to the power-supply rails. Input signals that can swing more than 0.3 V beyond the supply rails must be current-limited to 10 mA or less.
- If Military/Aerospace specified devices are required, contact the Texas Instruments Sales Office/Distributors for availability and specifications.
- Short-circuit to ground.

### 7.2 ESD Ratings

		VALUE	UNIT
$V_{(ESD)}$	Electrostatic discharge		
	Human-body model (HBM), per ANSI/ESDA/JEDEC JS-001 <sup>(1)</sup>	±1000	V
Charged-device model (CDM), per JEDEC specification JESD22-C101 <sup>(2)</sup>	±250		

- JEDEC document JEP155 states that 500-V HBM allows safe manufacturing with a standard ESD control process. Manufacturing with less than 500-V HBM is possible with the necessary precautions. Pins listed as ±2000 V may actually have higher performance.
- JEDEC document JEP157 states that 250-V CDM allows safe manufacturing with a standard ESD control process. Manufacturing with less than 250-V CDM is possible with the necessary precautions. Pins listed as ±750 V may actually have higher performance.

### 7.3 Recommended Operating Conditions

over operating free-air temperature range (unless otherwise noted)

	MIN	NOM	MAX	UNIT
Supply voltage (V+ - V-)	1.7		3.6	V
Specified ambient temperature	-40		125	°C

### 7.4 Thermal Information

THERMAL METRIC <sup>(1)</sup>	TLV8544		TLV8542		TLV8541	UNIT
	PW (TSSOP)	D (SOIC)	D (SOIC)	RUG (X2QFN)	DBV (SOT-23)	
	14 PINS	14 PINS	8 PINS	8 PINS	5 PINS	
$R_{\theta JA}$ Junction-to-ambient thermal resistance	124.5	104.1	141.6	188.3	244.6	°C/W
$R_{\theta JC(top)}$ Junction-to-case (top) thermal resistance	52.7	61.5	85.7	88.9	127.3	°C/W
$R_{\theta JB}$ Junction-to-board thermal resistance	66.2	59.9	84.7	100.2	79.4	°C/W
$\psi_{JT}$ Junction-to-top characterization parameter	7.3	22.9	36.3	3.9	44.1	°C/W
$\psi_{JB}$ Junction-to-board characterization parameter	65.7	59.5	84.0	100.3	78.8	°C/W
$R_{\theta JC(bottom)}$ Junction-to-case (bottom) thermal resistance	N/A	N/A	N/A	N/A	N/A	°C/W

- For more information about traditional and new thermal metrics, see the [Semiconductor and IC Package Thermal Metrics](#) application report.

## 7.5 Electrical Characteristics

 $T_A = 25^\circ\text{C}$ ,  $V_S = 1.8\text{ V to } 3.3\text{ V}$ ,  $V_{CM} = V_{OUT} = V_S / 2$ , and  $R_L \geq 10\text{ M}\Omega$  to  $V_S / 2$ , unless otherwise noted.

PARAMETER		TEST CONDITIONS	MIN	TYP	MAX	UNIT
<b>OFFSET VOLTAGE</b>						
$V_{OS}$	Input offset voltage	$V_{CM} = V^-$ , $V_S = 1.8\text{ V and } 3.3\text{ V}$	-3.1	See Plots	3.1	mV
		$V_{CM} = V^+$ , $V_S = 1.8\text{ V and } 3.3\text{ V}$	-3.4	See Plots	3.4	
$dV_{OS}/dT$	Input offset drift	$V_{CM} = V^-$ , $T_A = -40^\circ\text{C to } 125^\circ\text{C}$		0.8		$\mu\text{V}/^\circ\text{C}$
PSRR	Power-supply rejection ratio	$V_{CM} = V^-$ , $V_S = 1.8\text{ V and } 3.3\text{ V}$	66	90		dB
<b>INPUT VOLTAGE RANGE</b>						
$V_{CM}$	Common-mode voltage range	$V_S = 3.3\text{ V}$	0		3.3	V
CMRR	Common-mode rejection ratio	$(V^-) \leq V_{CM} \leq (V^+)$ , $V_S = 3.3\text{ V}$	60	80		dB
		$(V^-) \leq V_{CM} \leq (V^+) - 1.2\text{ V}$		90		
<b>INPUT BIAS CURRENT</b>						
$I_B$	Input bias current			100		fA
$I_{OS}$	Input offset current			100		fA
<b>INPUT IMPEDANCE</b>						
	Differential			2		pF
	Common mode			4		pF
<b>NOISE</b>						
$E_n$	Input voltage noise	$f = 0.1\text{ Hz to } 10\text{ Hz}$		8.6		$\mu\text{Vp-p}$
$e_n$	Input voltage noise density	$f = 1\text{ kHz}$		264		$\text{nV}/\sqrt{\text{Hz}}$
<b>OPEN-LOOP GAIN</b>						
$A_{OL}$	Open-loop voltage gain	$(V^-) + 0.3\text{ V} \leq V_O \leq (V^+) - 0.3\text{ V}$ , $R_L = 100\text{ k}\Omega$ to $V^+/2$		120		dB
<b>OUTPUT</b>						
$V_{OH}$	Voltage output swing from positive rail	$R_L = 100\text{ k}\Omega$ to $V^+/2$ , $V_S = 3.3\text{ V}$			12	mV
$V_{OL}$	Voltage output swing from negative rail	$R_L = 100\text{ k}\Omega$ to $V^+/2$ , $V_S = 3.3\text{ V}$			12	mV
$I_{SC}$	Short-circuit current	Sourcing, $V_O$ to $V^-$ , $V_{IN(\text{diff})} = 100\text{ mV}$ , $V_S = 3.3\text{ V}$		15		mA
		Sinking, $V_O$ to $V^+$ , $V_{IN(\text{diff})} = -100\text{ mV}$ , $V_S = 3.3\text{ V}$		30		
$Z_O$	Open loop output impedance	$f = 1\text{ kHz}$ , $I_O = 0\text{ mA}$		8		k $\Omega$
<b>FREQUENCY RESPONSE</b>						
GBP	Gain-bandwidth product	$C_L = 20\text{ pF}$ , $R_L = 10\text{ M}\Omega$		8		kHz
SR	Slew rate (10% to 90%)	$G = 1$ , rising edge, $C_L = 20\text{ pF}$		3.5		V/ms
		$G = 1$ , falling edge, $C_L = 20\text{ pF}$		4.5		
<b>POWER SUPPLY</b>						
$I_{Q-TLV8541}$	Quiescent Current	$V_{CM} = V^-$ , $I_O = 0\text{ mA}$ , $V_S = 3.3\text{ V}$		550	640	nA
$I_{Q-TLV8542}$	Quiescent Current, per channel	$V_{CM} = V^-$ , $I_O = 0\text{ mA}$ , $V_S = 3.3\text{ V}$		550	640	nA
$I_{Q-TLV8544}$	Quiescent current, per channel	$V_{CM} = V^-$ , $I_O = 0\text{ mA}$ , $V_S = 3.3\text{ V}$		500	640	nA

## 7.6 Typical Characteristics

TA = 25°C, RL = 10 MΩ to VS/2, CL = 20 pF, VCM = VS / 2 V unless otherwise specified.

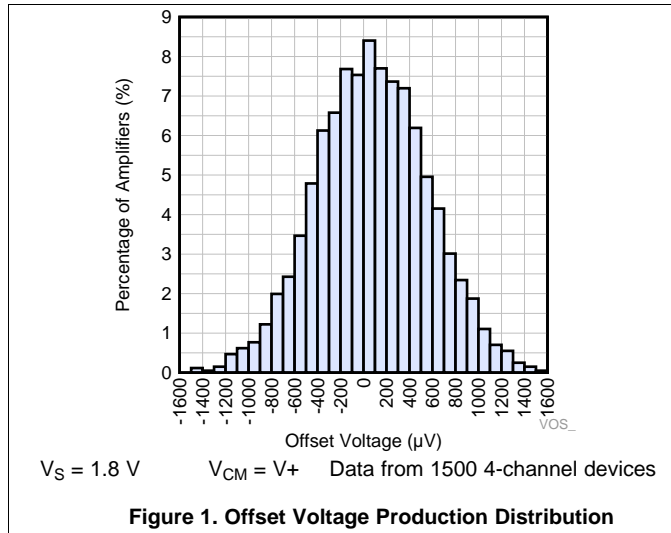

Figure 1. Offset Voltage Production Distribution

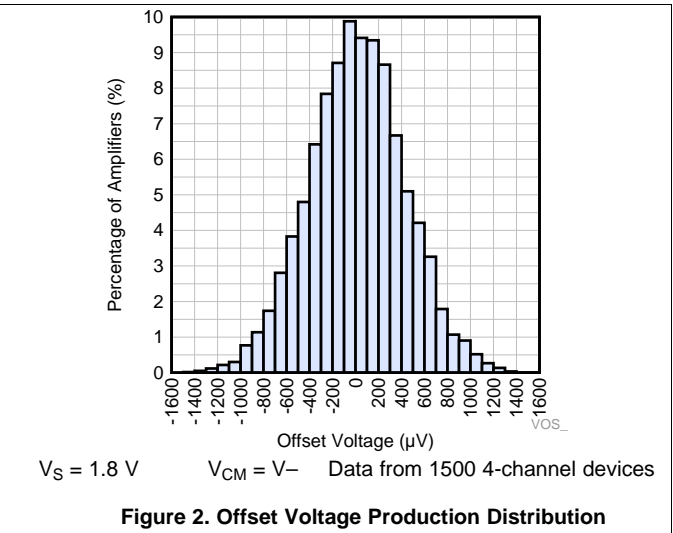

Figure 2. Offset Voltage Production Distribution

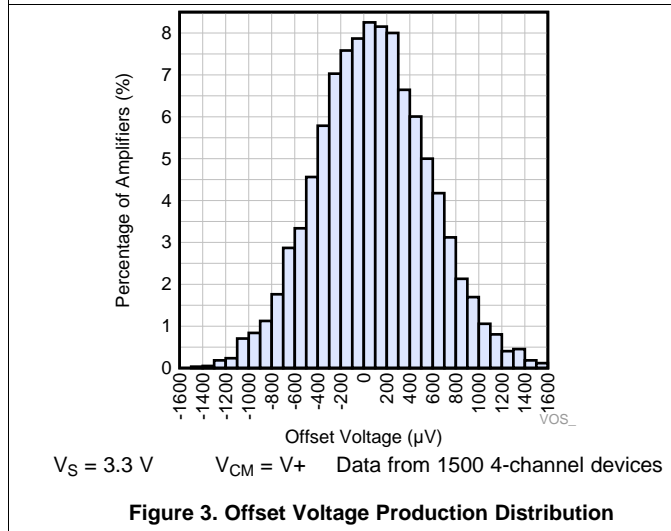

Figure 3. Offset Voltage Production Distribution

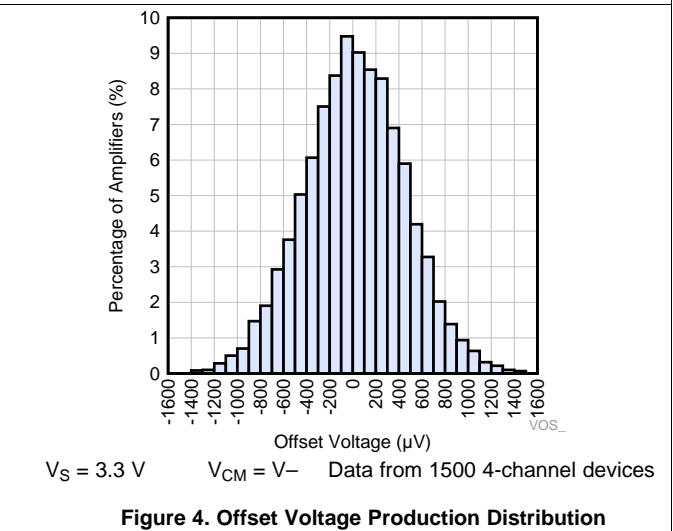

Figure 4. Offset Voltage Production Distribution

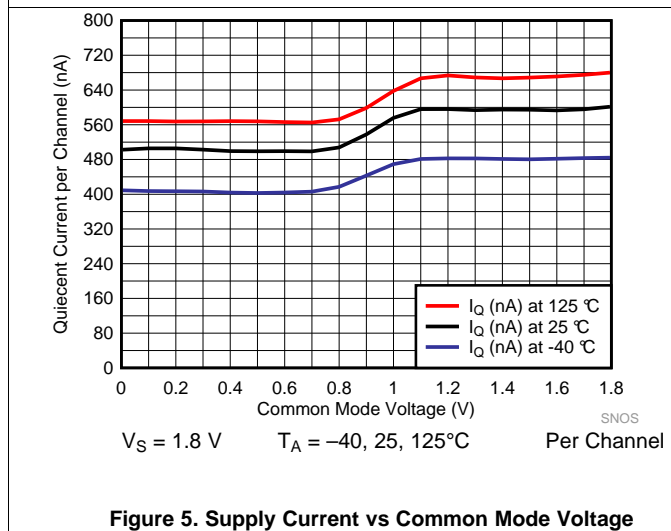

Figure 5. Supply Current vs Common Mode Voltage

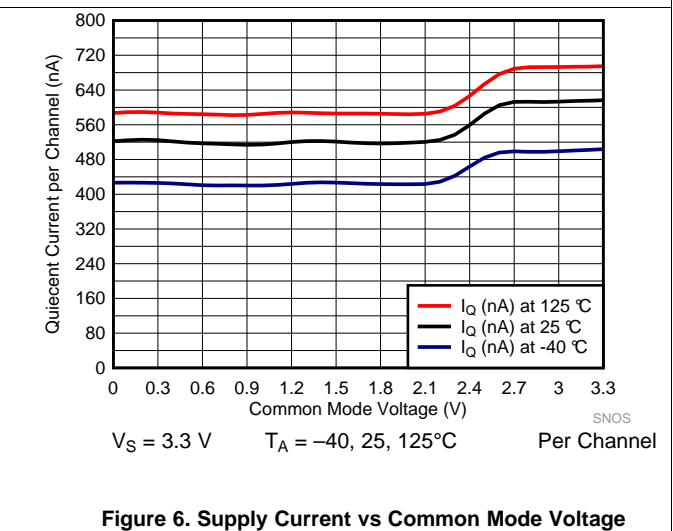

Figure 6. Supply Current vs Common Mode Voltage

### Typical Characteristics (continued)

$T_A = 25^\circ\text{C}$ ,  $R_L = 10\text{ M}\Omega$  to  $V_S/2$ ,  $C_L = 20\text{ pF}$ ,  $V_{CM} = V_S / 2\text{ V}$  unless otherwise specified.

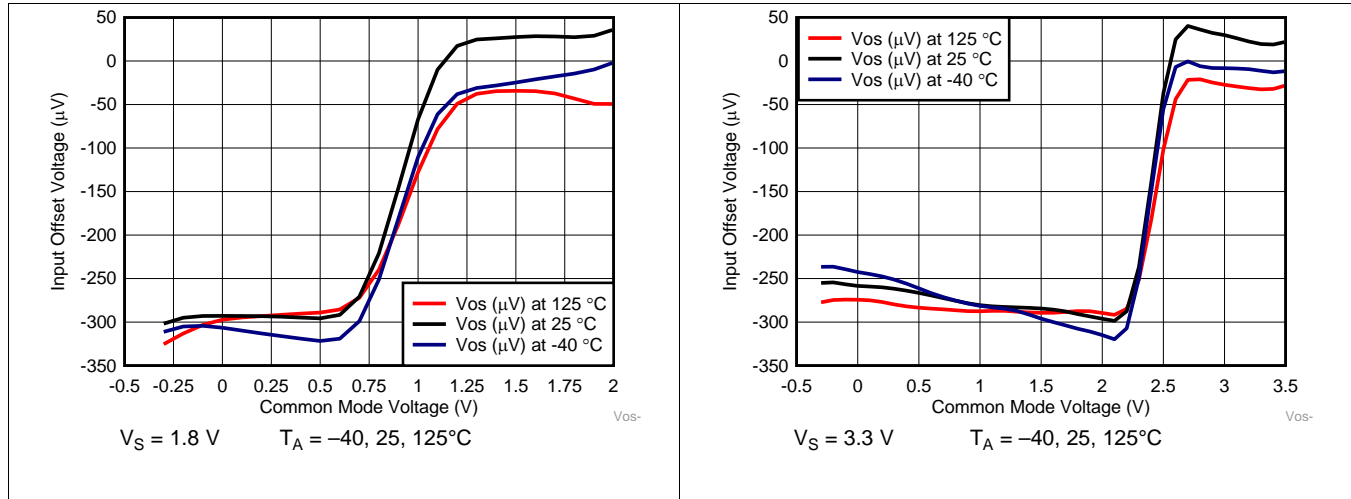

Figure 7. Typical Offset Voltage vs Common Mode Voltage

Figure 8. Typical Offset Voltage vs Common Mode Voltage

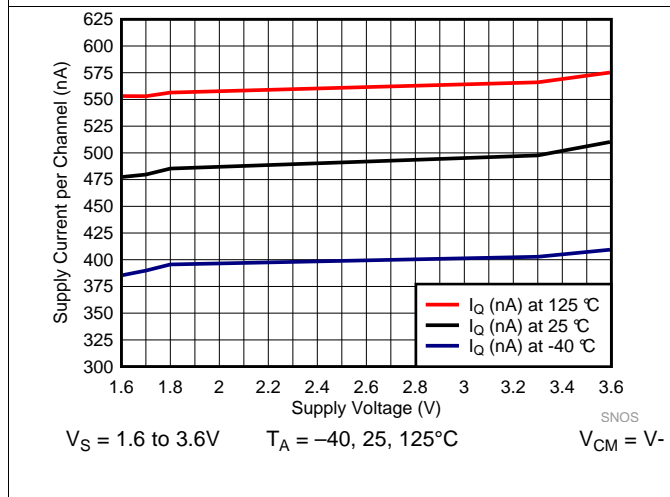

Figure 9. Supply Current vs Supply Voltage, Low VCM

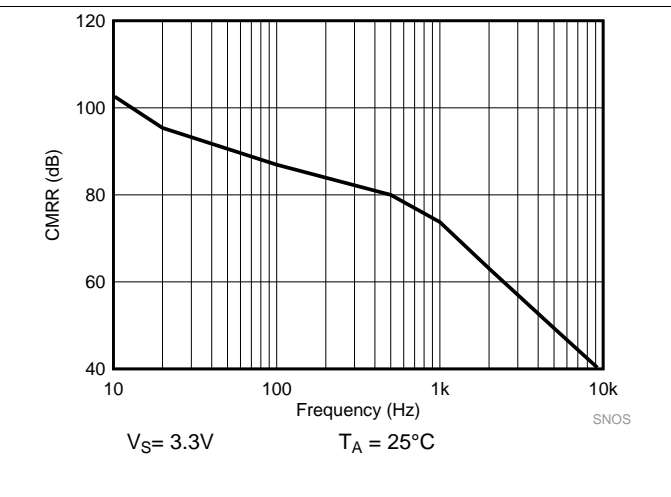

Figure 10. CMRR vs Frequency

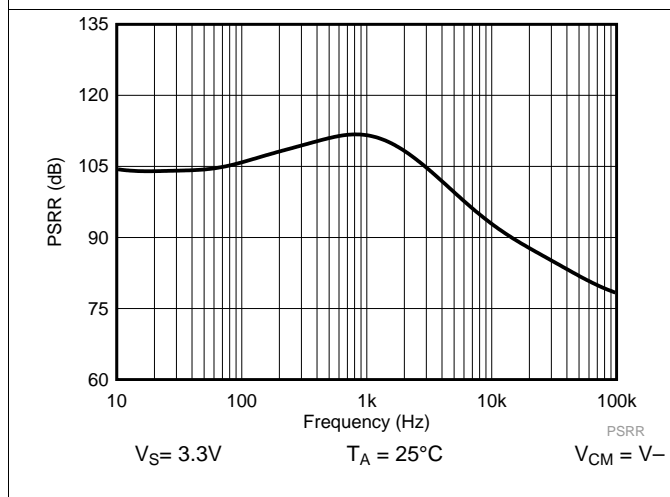

Figure 11. PSRR vs Frequency

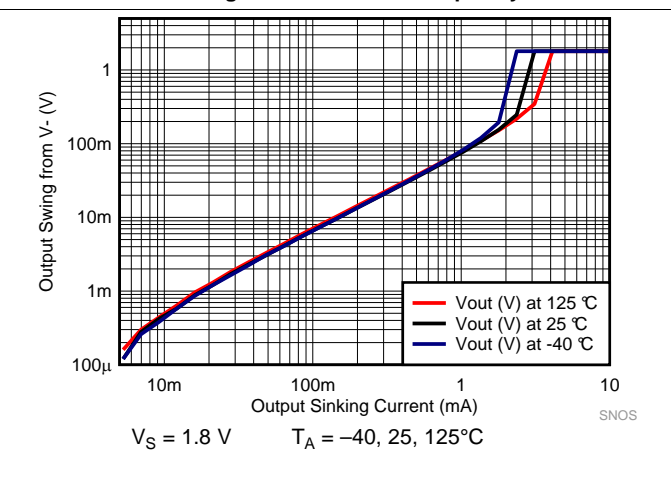
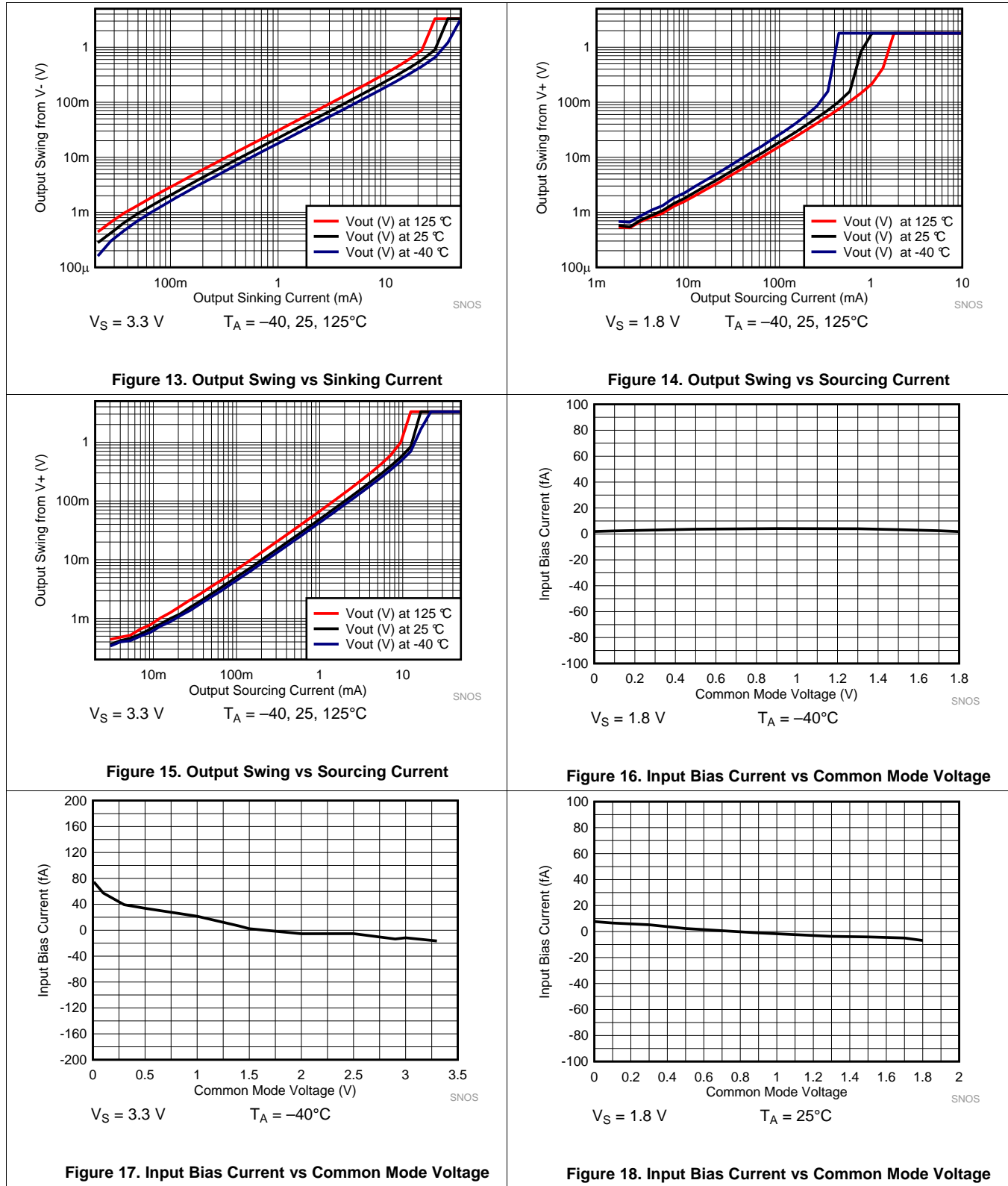

Figure 12. Output Swing vs Sinking Current

Typical Characteristics (continued)

TA = 25°C, RL = 10 MΩ to VS/2, CL = 20 pF, VCM = VS / 2 V unless otherwise specified.



### Typical Characteristics (continued)

$T_A = 25^\circ\text{C}$ ,  $R_L = 10\text{ M}\Omega$  to  $V_S/2$ ,  $C_L = 20\text{ pF}$ ,  $V_{CM} = V_S / 2\text{ V}$  unless otherwise specified.

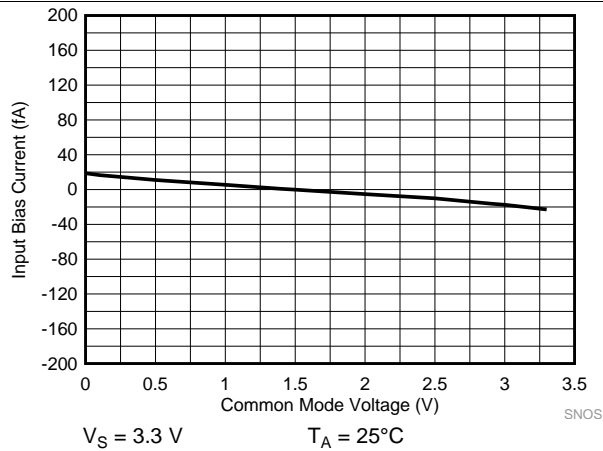

Figure 19. Input Bias Current vs Common Mode Voltage

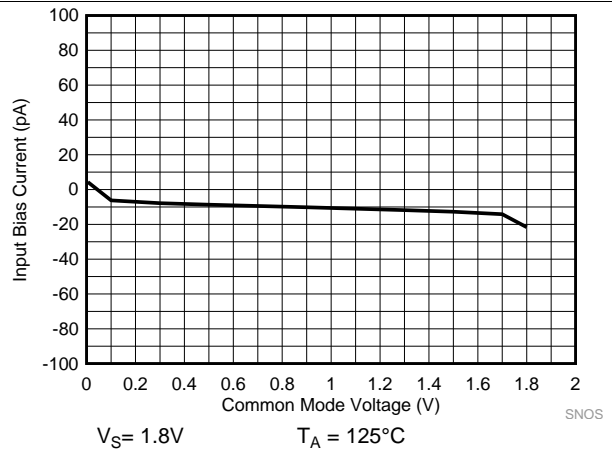

Figure 20. Input Bias Current vs Common Mode Voltage

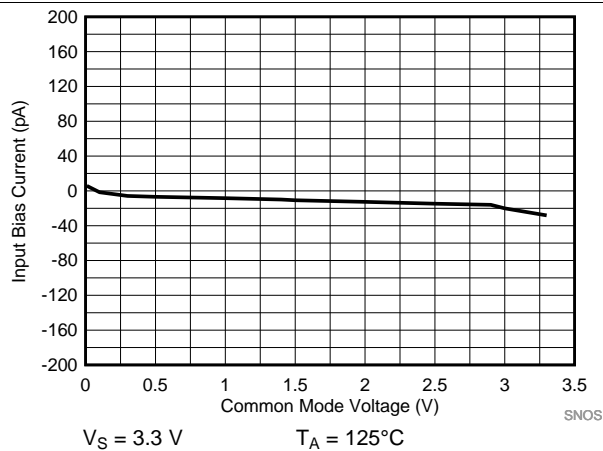

Figure 21. Input Bias Current vs Common Mode Voltage

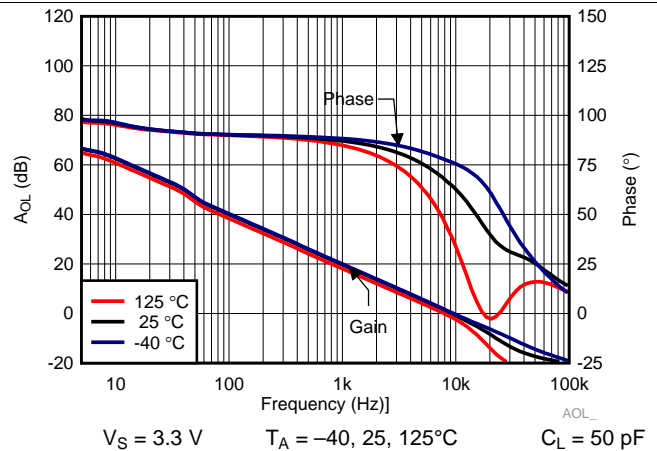

Figure 22. Open Loop Gain and Phase



Figure 23. Input Voltage Noise vs Frequency



Figure 24. Open Loop Output Impedance

Typical Characteristics (continued)

$T_A = 25^\circ\text{C}$ ,  $R_L = 10\text{ M}\Omega$  to  $V_S/2$ ,  $C_L = 20\text{ pF}$ ,  $V_{CM} = V_S / 2\text{ V}$  unless otherwise specified.

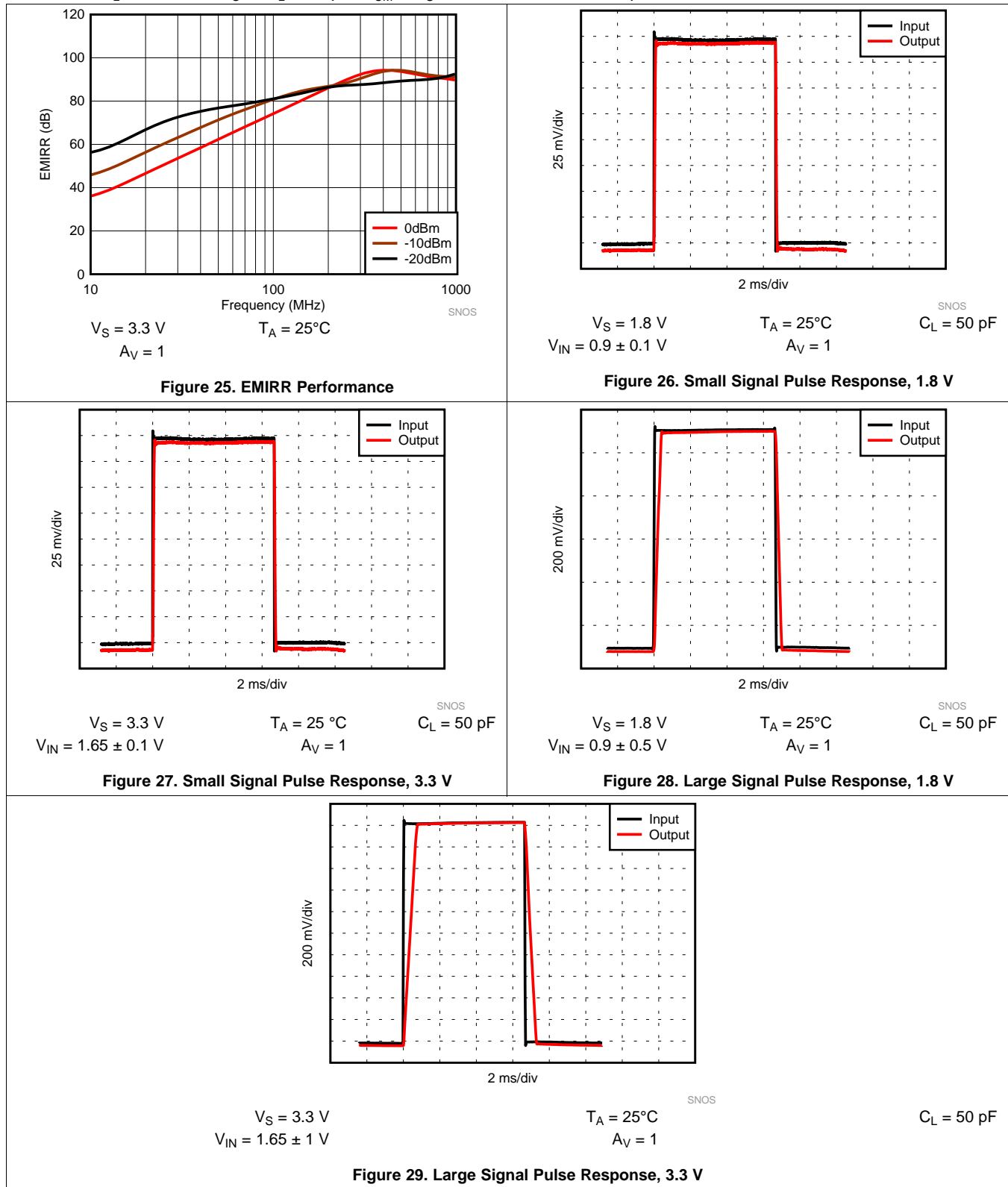

## 8 Detailed Description

### 8.1 Overview

The TLV854x amplifiers are unity-gain stable and can operate on a single supply, making them highly versatile and easy to use.

Parameters that vary significantly with operating voltages or temperature are shown in the [Typical Characteristics](#) curves.

### 8.2 Functional Block Diagram

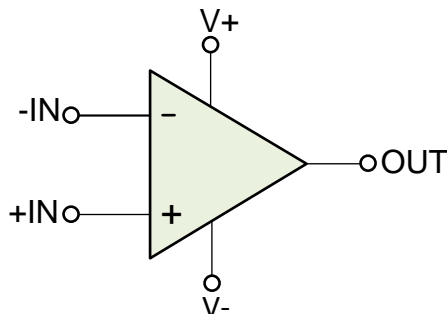

### 8.3 Feature Description

The differential inputs of the TLV854x device consist of a non-inverting input (+IN) and an inverting input (–IN). The device amplifies only the difference in voltage between the two inputs, which is called the differential input voltage. The output voltage of the op-amps  $V_{OUT}$  are given by [Equation 1](#):

$$V_{OUT} = A_{OL} [(+IN) - (-IN)]$$

where

- $A_{OL}$  is the open-loop gain of the amplifier, typically around 100 dB. (1)

### 8.4 Device Functional Modes

#### 8.4.1 Rail-To-Rail Input

The input common-mode voltage range of the TLV854x extends to the supply rails. This is achieved with a complementary input stage — an N-channel input differential pair in parallel with a P-channel differential pair. The N-channel pair is active for input voltages close to the positive rail, typically  $(V+) - 800\text{ mV}$  to  $200\text{ mV}$  above the positive supply, while the P-channel pair is on for inputs from  $300\text{ mV}$  below the negative supply to approximately  $(V+) - 800\text{ mV}$ . There is a small transition region, typically  $(V+) - 1.2\text{ V}$  to  $(V+) - 0.8\text{ V}$ , in which both pairs are on. This 400-mV transition region can vary 200 mV with process variation. Within the 400-mV transition region PSRR, CMRR, offset voltage, offset drift, and THD may be degraded compared to operation outside this region.

#### 8.4.2 Supply Current Changes Over Common Mode

Because of the ultra-low supply current, changes in common mode voltages cause a noticeable change in the supply current as the input stages transition through the transition region, as shown in [Figure 30](#).

## Device Functional Modes (continued)

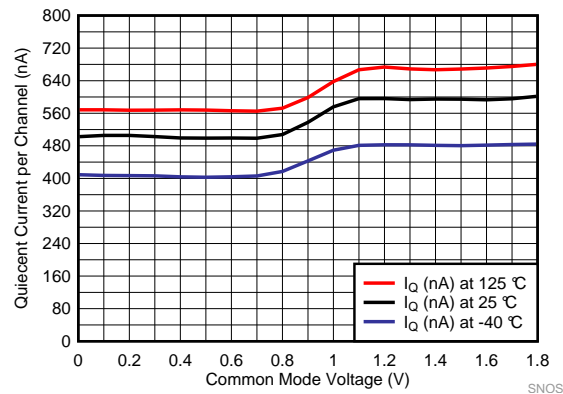

Figure 30. Supply Current Change Over Common Mode at 1.8 V

For the lowest supply current operation, keep the input common mode range between  $V^-$  and 1 V below  $V^+$ .

### 8.4.3 Design Optimization With Rail-To-Rail Input

In most applications, operation is within the range of only one differential pair. However, some applications can subject the amplifier to a common-mode signal in the transition region. Under this condition, the inherent mismatch between the two differential pairs may lead to degradation of the CMRR and THD. The unity-gain buffer configuration is the most problematic as it traverses through the transition region if a sufficiently wide input swing is required.

### 8.4.4 Design Optimization for Nanopower Operation

When designing for ultra-low power, choose system components carefully. To minimize current consumption, select large-value resistors. Any resistors react with stray capacitance in the circuit and the input capacitance of the operational amplifier (op amp). These parasitic RC combinations can affect the stability of the overall system. A feedback capacitor may be required to assure stability and limit overshoot or gain peaking.

When possible, use AC coupling and AC feedback to reduce static current draw through the feedback elements. Use film or ceramic capacitors because large electrolytics may have static leakage currents in the tens to hundreds of nanoamps.

### 8.4.5 Common-Mode Rejection

The CMRR for the TLV854x is specified in two ways so the best match for a given application may be used. First, the CMRR of the device in the common-mode range below the transition region ( $V_{CM} < (V^+) - 1.2$  V) is given. This specification is the best indicator of the capability of the device when the application requires use of one of the differential input pairs. Second, the CMRR at  $V_S = 3.3$  V over the entire common-mode range is specified.

### 8.4.6 Output Stage

The TLV854x output voltage swings 20 mV from rails at a 3.3-V supply, which provides the maximum possible dynamic range at the output. This is particularly important when operating on low supply voltages.

The TLV854x maximum output voltage swing defines the maximum swing possible under a particular output load.

## Device Functional Modes (continued)

### 8.4.7 Driving Capacitive Load

The TLV854x is internally compensated for stable unity-gain operation, with a 8-kHz typical gain bandwidth. However, the unity-gain follower is the most sensitive configuration-to-capacitive load. The combination of a capacitive load placed directly on the output of an amplifier along with the output impedance of the amplifier creates a phase lag, which reduces the phase margin of the amplifier. If the phase margin is significantly reduced, the response is under-damped, which causes peaking in the transfer and, when there is too much peaking, the op amp might start oscillating.

In order to drive heavy ( $> 50$  pF) capacitive loads, use an isolation resistor,  $R_{ISO}$ , as shown in Figure 31. By using this isolation resistor, the capacitive load is isolated from the output of the amplifier. The larger the value of  $R_{ISO}$ , the more stable the amplifier will be. If the value of  $R_{ISO}$  is sufficiently large, the feedback loop is stable, independent of the value of  $C_L$ . However, larger values of  $R_{ISO}$  (e.g. 50 k $\Omega$ ) result in reduced output swing and reduced output current drive.

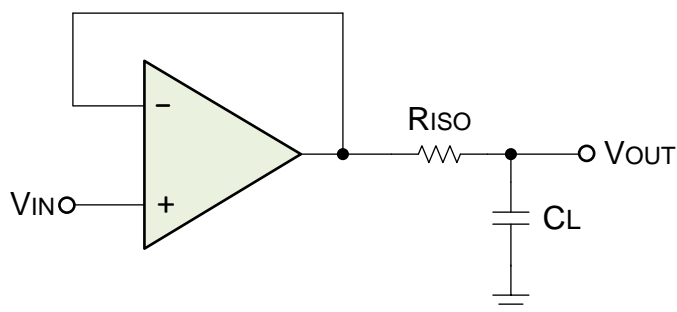

**Figure 31. Resistive Isolation of Capacitive Load**

## 9 Application and Implementation

### NOTE

Information in the following applications sections is not part of the TI component specification, and TI does not warrant its accuracy or completeness. TI's customers are responsible for determining suitability of components for their purposes. Customers should validate and test their design implementation to confirm system functionality.

### 9.1 Application Information

The TLV854x is a nanopower op amps that provides 8-kHz bandwidth with only 500-nA typical quiescent current per channel and near precision drift specifications at a low cost. These rail-to-rail input and output amplifiers are specifically designed for battery-powered applications. The input common-mode voltage range extends to the power-supply rails and the output swings to within millivolts of the rails, maintaining a wide dynamic range.

## 9.2 Typical Application: Battery-Powered Wireless PIR Motion Detectors

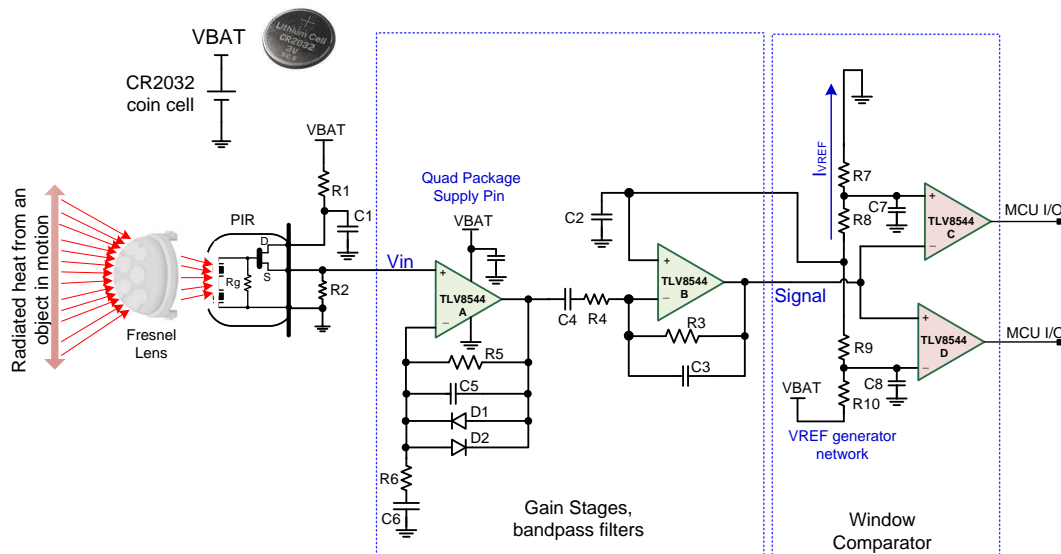

Figure 32. PIR Motion Detector Circuit

### 9.2.1 Design Requirements

Smart building automation systems employ a large number of various sensing nodes distributed throughout small, medium, and large infrastructures. The sensing nodes measure motion, temperature, vibration, and other parameters of interest. Wireless nodes are monitored in a central location. Because of the large number of distributed nodes, battery-operation and cost-optimized electronic components are required. Typically, the wireless nodes need to run on a single CR2032 coin battery for eight to ten years.

For more information see [Design of Ultra-Low Power Discrete Signal Conditioning Circuit for Battery-Power, Ultra-Low-Power Wireless PIR Motion Detector Reference Design](#) and [BOOSTXL-TLV8544PIR User's Guide](#). The BOOSTXL-TLV8544PIR along with the companion CC2650 LaunchPad, [LAUNCHXL-CC2650](#) can be obtained from the TI website for hands-on experiments.

### 9.2.2 Detailed Design Procedure

Referring to [Figure 32](#), the TLV8544 4-channel op amp is powered directly by a 3.3-V CR2032 coin battery. The first two amplifier stages of the TLV8544 implement active filter functionality. The remaining two amplifiers of the TLV8544 are used for building a window comparator. The comparator flags the detection of a motion event to an ultra-low-power wireless microcontroller on the same board. Due to the higher gain in the filter stages and higher output noise from the sensor, it is necessary to optimize the placement of the high-frequency filter pole and the window comparator thresholds to avoid false detection.

The first two amplifiers (A and B) in the circuit are used in identical active bandpass filters with corner frequencies of 0.7 and 10.6 Hz. Each filter stage has a gain of about 220 V/V to account for the reduced sensitivity of the sensor due to the low current biasing of the PIR sensor. Considering the 8-kHz unity gain bandwidth (UGBW) product of the TLV8544, the bandwidth of each stage is limited to approximately 36 Hz. The above choice of cutoff frequencies give a relatively wide bandwidth to detect a person running in the field of view, yet narrow enough to limit the peak-to-peak noise at the output of the filters.

Amplifier A is a noninverting gain/filter stage providing the high input impedance needed to prevent loading of the sensor. The DC gain of the stage due to the presence of C6 is unity. Therefore, the sensor output provides the bias voltage needed at the A stage to avoid clipping of the lower cycle of the input signal. Diodes D1 and D2 limit the output signal, avoiding overdriving of the second stage and consequently placing a large charge on coupling capacitor C4, which helps with the recovery time.

#### 9.2.2.1 Calculation of the Cutoff Frequencies and Gain of Stage A:

The low cutoff frequency of the bandpass filter in stage A is:

## Typical Application: Battery-Powered Wireless PIR Motion Detectors (continued)

$$f_{\text{Clow}} = \frac{1}{2\pi \times R_6 \times C_6} \quad (2)$$

Choosing  $R_6 = 6.81 \text{ k}\Omega$  and  $C_6 = 33 \text{ }\mu\text{F}$ , the low cutoff frequency is  $f_{\text{Clow}} = 0.71 \text{ Hz}$ . The high cutoff frequency of the filter is:

$$f_{\text{Chigh}} = \frac{1}{2\pi \times R_5 \times C_5} \quad (3)$$

For  $R_5 = 1.5 \text{ M}\Omega$  and  $C_5 = 0.01 \text{ }\mu\text{F}$ , the high cutoff frequency is  $f_{\text{Chigh}} = 10.6 \text{ Hz}$ . The gain of the stage is:

$$G = 1 + \frac{R_5}{R_6} \quad (4)$$

Choosing  $R_5 = 1.5 \text{ M}\Omega$  and  $R_6 = 6.81 \text{ k}\Omega$ , the gain of the stage *A* is  $G = 221.26 \text{ V/V}$  (46.9 dB).

### 9.2.2.2 Calculation of the Cutoff Frequencies and Gain of Stage B

As shown in [Figure 32](#), amplifier *B* is an inverting bandpass filter and gain stage. Capacitor  $C_4$  creates an AC coupled path between the *A* and the *B* stages. Thus the signal level must be shifted at the input of the amplifier *B*. This is done by connecting a midpoint voltage of the reference voltage dividers comprising  $R_{10}$ ,  $R_9$ ,  $R_8$  and  $R_7$  to the non-inverting input of amplifier *B*, biasing the input signal to the mid-rail (1.65 V). A very large feedback resistor  $R_3$  is chosen to minimize the dynamic current due to presence of peak-to-peak noise voltage at the output of this stage.

The low cutoff frequency of the filter of the stage *B* is:

$$f_{\text{Clow}} = \frac{1}{2\pi \times R_4 \times C_4} \quad (5)$$

Choosing  $R_4 = 68.1 \text{ k}\Omega$  and  $C_4 = 3.3 \text{ }\mu\text{F}$ , the low cutoff frequency is  $f_{\text{Clow}} = 0.71 \text{ Hz}$ . The high cutoff frequency of the filter is:

$$f_{\text{Chigh}} = \frac{1}{2\pi \times R_3 \times C_3} \quad (6)$$

For  $R_3 = 15 \text{ M}\Omega$  and  $C_3 = 1000 \text{ pF}$ , the high cutoff frequency is  $f_{\text{Chigh}} = 10.6 \text{ Hz}$ . The gain of the stage is:

$$G = -\frac{R_3}{R_4} \quad (7)$$

For  $R_3 = 15 \text{ M}\Omega$  and  $R_4 = 68.1 \text{ k}\Omega$ , the gain is calculated  $|G| = 220.26 \text{ V/V}$  (46.9 dB).

### 9.2.2.3 Calculation of the Total Gain of Stages A and B

The overall gain of the two stages *A* and *B* is:  $G_{\text{Total}} = G_A \times G_B = 221.26 \times 220.26 = 48810 \text{ V/V} = 93.77 \text{ dB}$ .

### 9.2.2.4 Window Comparator Stage

The signal from a moving object in front of the PIR sensor, after amplification and filtering, is connected to a window comparator. The comparator converts the analog signal to digital pulses for interrupting an on-board microcontroller unit (MCU), flagging detection of motion. A different approach is to digitize the analog signal continuously by an analog-to-digital converter (ADC) and implement the comparator functionality in the digital domain. This method has the advantage of enabling the post processing of the data to reduce the chance of false detection. However, continuous conversion and processing of data by the MCU increases the power consumption, lowering the lifetime of the battery substantially.

Rather than using a separate low-power comparator integrated circuits to implement the window comparator section of the circuit, the remaining op amps in the TLV8544 package are used to implement the comparator stage. Benefits of this approach include fewer components and thus reduced system cost.

Although an op amp can sometimes be used as a comparator, an amplifier cannot be used as a comparator interchangeably in all applications because of relatively long recovery time of the amplifier from output saturation and relatively long propagation delay due to internal compensation. Particularly, the nanopower op amps have very slow slew rate, limiting their usage as a comparator in only applications with very low frequency input signal. Fortunately, PIR sensor signals are relatively slow and this should not be an issue.

## Typical Application: Battery-Powered Wireless PIR Motion Detectors (continued)

The new TLV8544 device is particularly suitable for implementing a window comparator in a battery operated PIR motion detector application because of its rail-to-rail operation capability, relatively low offset voltage, low offset voltage drift, very low bias current, and nanopower consumption, all at an optimal cost. The input signal of the comparator stage in the presence of moving heat source across the sensor is shown in Figure 33. The signal is centered at mid-rail and can swing up or down from the center.

The window comparator is a combination of a non-inverting comparator implemented with amplifier *D* and an inverting comparator implemented with amplifier *C*, as shown in Figure 32.

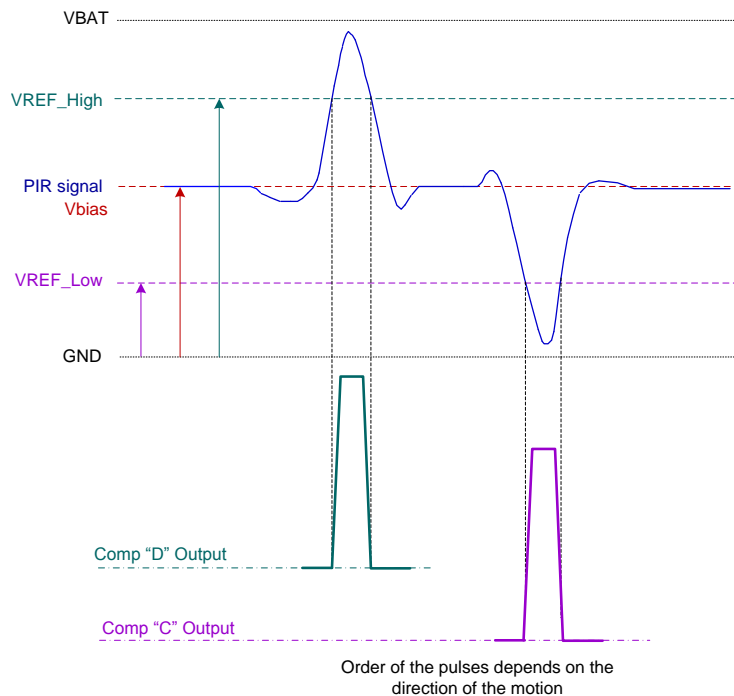

Figure 33. Ideal Amplified PIR Signal and the Output of the Window Comparator Circuit

### 9.2.2.5 Reference Voltages

Referring to Figure 32, the divider networks comprising R7, R8, R9, and R10, generate the reference voltages *VREF\_High* and *VREF\_Low* of the window comparator. The center point of the divider provides the bias voltage of the gain in the stage *B* through the connection to the noninverting input of the amplifier.

Due to the very low bias current of the TLV8544 device, it is possible to use very large values of resistors in the divider networks to minimize the current to ground through the resistors to a negligible amount. For R7 = R8 = R9 = R10 = 15 MΩ:

$$V_{REF\_High} = \left( \frac{R7 + R8 + R9}{R7 + R8 + R9 + R10} \right) V_{CC} = \frac{4.5 \times 10^6}{6 \times 10^6} \times V_{CC} = 0.75 \times V_{CC} \quad (8)$$

$$V_{REF\_Low} = \left( \frac{R7}{R8 + R9 + R10 + R7} \right) V_{CC} = \frac{1.5 \times 10^6}{6 \times 10^6} \times V_{CC} = 0.25 \times V_{CC} \quad (9)$$

Low leakage ceramic capacitors C7, and C8, maintain constant threshold voltages, preventing potential chatter at the output of the comparators. It should be noted that using cheap electrolytic capacitors must be avoided as they have high (many μA) leakage current. The comparator outputs stay low in the absence of motion across the sensor. In the presence of motion, comparators *C* and *D* generate *high* output pulses as shown in Figure 33. The order of the pulses depends on the direction of the motion in front of the sensor.

## Typical Application: Battery-Powered Wireless PIR Motion Detectors (continued)

### 9.2.3 Application Curve

Scope plots of the amplified PIR signal at the input of the noninverting comparator and the corresponding output signal are shown in [Figure 34](#) and [Figure 35](#). As the PIR signal (blue line) crosses the VREF\_High threshold, the output of the comparator switches from the cutoff (slightly higher than ground) state to the saturation state (slightly lower than  $V_{BAT} = 3.3\text{ V}$ ). Depending on the speed of the object, the PIR signal peaks to its maximum and roles off within several seconds. When the signal crosses the VREF\_High threshold on the way down, the output of the noninverting amplifier toggles back to the cutoff region (low).

The data for plot of [Figure 34](#) was captured using the [BOOSTXL-TLV8544PIR](#) board. Because the motion was created at very close proximity of the sensor on the booster board used to collect the data, the signal was limited by the diode in the first stage as shown in the plot.



**Figure 34. Noninverting Comparator Input and Output Signals**

Referring to [Figure 34](#), the output of the inverting comparator during the lower cycle of the PIR signal switches from the cutoff region to the saturation region as the input signal crosses the VREF\_Low threshold.

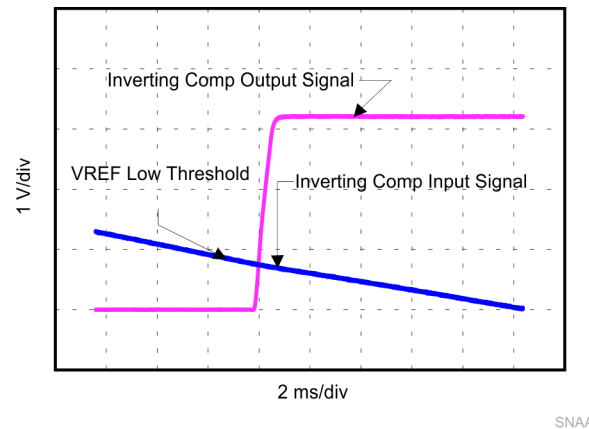

**Figure 35. Noninverting Comparator Input and Output Signals**

### 9.3 Typical Application: 60-Hz Twin T Notch Filter

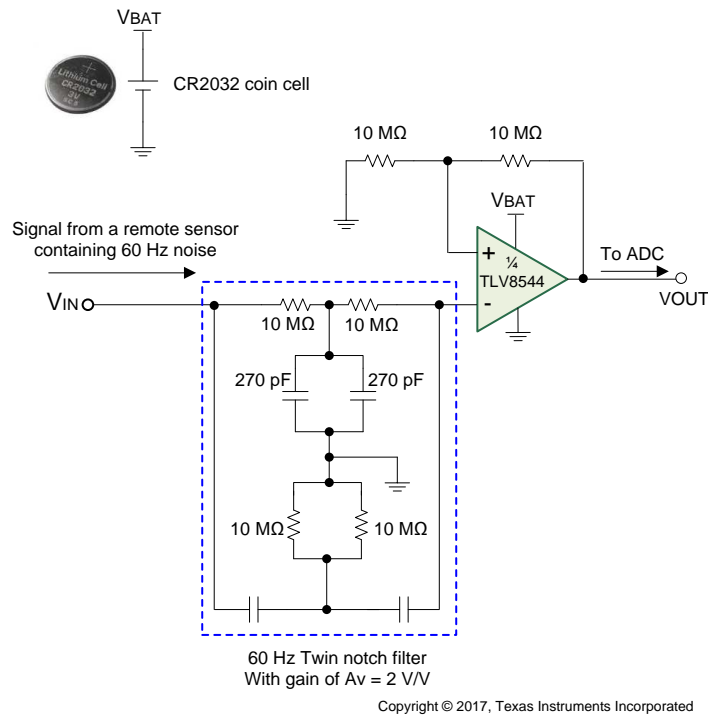

Figure 36. 60 Hz-Notch Filter

#### 9.3.1 Design Requirements

Small signals from transducers in remote and distributed sensing applications commonly suffer strong 60-Hz interference from AC power lines. The circuit of Figure 36 filters out (notches out) the 60 Hz and provides a system gain of  $A_V = 2 \text{ V/V}$  for the sensor signal represented by a 1-kHz sine wave. Similar stages may be cascaded to remove 2<sup>nd</sup> and 3<sup>rd</sup> harmonics of 60 Hz. Thanks to the nanopower consumption of the TLV8544, even five such circuits can run for 9.5 years from a small CR2032 lithium cell. These batteries have a nominal voltage of 3 V and an end of life voltage of 2 V. With an operating voltage from 1.7 V to 3.6 V the TLV8544 device can function over this voltage range.

#### 9.3.2 Detailed Design Procedure

The notch frequency is set by:

$$F_0 = 1 / 2\pi RC. \quad (10)$$

To achieve a 60-Hz notch use  $R = 10 \text{ M}\Omega$  and  $C = 270 \text{ pF}$ . If eliminating 50-Hz noise, use  $R = 11.8 \text{ M}\Omega$  and  $C = 270 \text{ pF}$ .

The twin T notch filter works by having two separate paths from  $V_{IN}$  to the input of the amplifier. A low-frequency path through the series input resistors and another separate high-frequency path through the series input capacitors. However, at frequencies around the notch frequency, the two paths have opposing phase angles, and the two signals tend to cancel at the input of the amplifier.

To ensure that the target center frequency is achieved and to maximize the notch depth (Q factor) the filter must be as balanced as possible. To obtain circuit balance, while overcoming limitations of available standard resistor and capacitor values, use passives in parallel to achieve the  $2C$  and  $R/2$  circuit requirements for the filter components that connect to ground.

To make sure passive component values stay as expected, clean the board with alcohol, rinse with deionized water, and air dry. Make sure board remains in a relatively low humidity environment to minimize moisture which may increase the conductivity of board components. Also large resistors come with considerable parasitic stray capacitance which effects can be reduced by cutting out the ground plane below components of concern.

### Typical Application: 60-Hz Twin T Notch Filter (continued)

Large resistors are used in the feedback network to minimize battery drain. When designing with large resistors, resistor thermal noise, op amp current noise, as well as op-amp voltage noise, must be considered in the noise analysis of the circuit. The noise analysis for the circuit in [Figure 36](#) can be done over a bandwidth of 2 kHz, which takes the conservative approach of overestimating the bandwidth (TLV8544 typical  $GBW/A_V$  is lower, where  $A_V$  is the gain of the system). The total noise at the output is approximately 800  $\mu\text{Vpp}$ , which is excellent considering the total consumption of the circuit is only 500 nA per channel. The dominant noise terms are op-amp voltage noise, current noise through the feedback network (430  $\mu\text{Vp-p}$ ), and current noise through the notch filter network (280  $\mu\text{Vp-p}$ ). Thus the total noise of the circuit is below 1/2 LSB of a 10-bit system with a 2-V reference, which is 1 mV.

#### 9.3.3 Application Curve

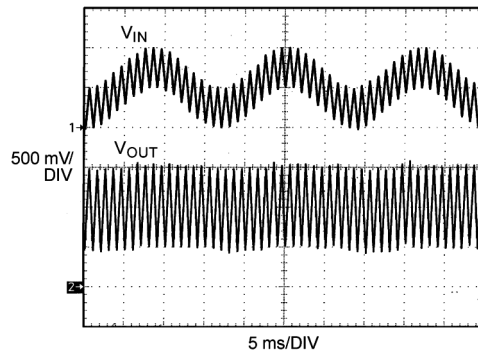

**Figure 37. 60-Hz Notch Filter Waveform**

#### 9.4 Dos and Don'ts

Do properly bypass the power supplies.

Do add series resistance to the output when driving capacitive loads, particularly cables, multiplexers, and ADC inputs.

Do add series current limiting resistors and external Schottky clamp diodes if input voltage is expected to exceed the supplies. Limit the current to 1 mA or less (1  $\text{K}\Omega$  per volt).

### 10 Power Supply Recommendations

The TLV854x is specified for operation from 1.7 V to 3.6 V ( $\pm 0.85$  V to  $\pm 1.8$  V) over a  $-40^\circ\text{C}$  to  $+125^\circ\text{C}$  temperature range. Parameters that can exhibit significant variance with regard to operating voltage or temperature are presented in the [Typical Characteristics](#).

#### CAUTION

Supply voltages larger than 3.6 V can permanently damage the device.

For proper operation, the power supplies must be properly decoupled. For decoupling the supply lines it is suggested that 100-nF capacitors be placed as close as possible to the op-amp power supply pins. For single supply, place a capacitor between  $V+$  and  $V-$  supply leads. For dual supplies, place one capacitor between  $V+$  and ground and one capacitor between  $V-$  and ground.

Low bandwidth nanopower devices do not have good high frequency ( $> 1$  kHz) AC PSRR rejection against high-frequency switching supplies and other 1-kHz and above noise sources, so extra supply filtering is recommended if kilohertz or above noise is expected on the power supply lines.

## 11 Layout

### 11.1 Layout Guidelines

- The V+ pin must be bypassed to ground with a low ESR capacitor.
- The optimum placement is closest to the V+ and ground pins.
- Take care to minimize the loop area formed by the bypass capacitor connection between V+ and ground.
- Connect the ground pin to the PCB ground plane at the pin of the device.
- Place the feedback components as close as possible to the device to minimize stray impedance.

### 11.2 Layout Example

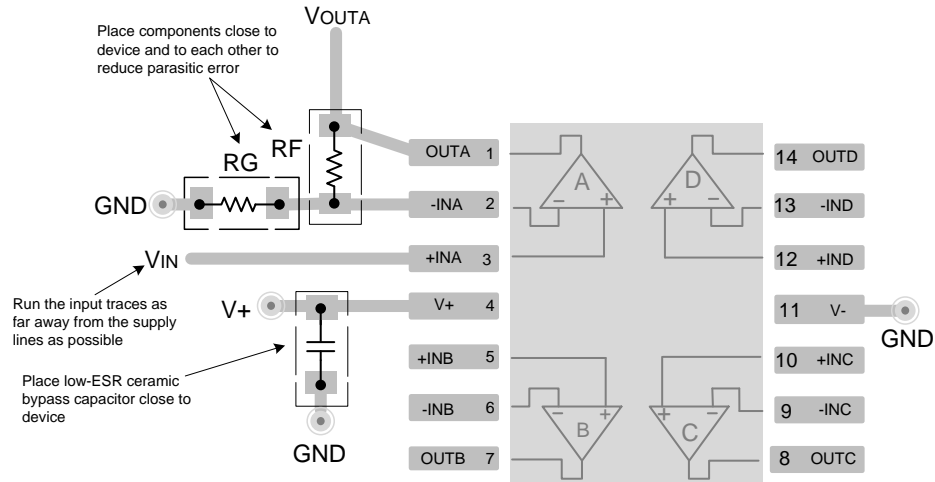

Figure 38. Layout Example of a Typical Dual Channel Package (Top View)

## 12 Device and Documentation Support

### 12.1 Device Support

#### 12.1.1 Development Support

[TINA-TI SPICE-Based Analog Simulation Program](#)

[DIP Adapter Evaluation Module](#)

[TI Universal Operational Amplifier Evaluation Module](#)

[TI FilterPro Filter Design Software](#)

### 12.2 Documentation Support

#### 12.2.1 Related Documentation

For related documentation, see the following:

- [AN-1798 Designing with Electro-Chemical Sensors](#)
- [AN-1803 Design Considerations for a Transimpedance Amplifier](#)
- [AN-1852 Designing With pH Electrodes](#)
- [Compensate Transimpedance Amplifiers Intuitively](#)
- [Transimpedance Considerations for High-Speed Operational Amplifiers](#)
- [Noise Analysis of FET Transimpedance Amplifiers](#)
- [Circuit Board Layout Techniques](#)
- [Handbook of Operational Amplifier Applications](#)

### 12.3 Related Links

The table below lists quick access links. Categories include technical documents, support and community resources, tools and software, and quick access to order now.

**Table 1. Related Links**

PARTS	PRODUCT FOLDER	ORDER NOW	TECHNICAL DOCUMENTS	TOOLS & SOFTWARE	SUPPORT & COMMUNITY
TLV8544	<a href="#">Click here</a>	<a href="#">Click here</a>	<a href="#">Click here</a>	<a href="#">Click here</a>	<a href="#">Click here</a>
TLV8542	<a href="#">Click here</a>	<a href="#">Click here</a>	<a href="#">Click here</a>	<a href="#">Click here</a>	<a href="#">Click here</a>
TLV8541	<a href="#">Click here</a>	<a href="#">Click here</a>	<a href="#">Click here</a>	<a href="#">Click here</a>	<a href="#">Click here</a>

### 12.4 Receiving Notification of Documentation Updates

To receive notification of documentation updates, navigate to the device product folder on ti.com. In the upper right corner, click on *Alert me* to register and receive a weekly digest of any product information that has changed. For change details, review the revision history included in any revised document.

### 12.5 Community Resources

The following links connect to TI community resources. Linked contents are provided "AS IS" by the respective contributors. They do not constitute TI specifications and do not necessarily reflect TI's views; see TI's [Terms of Use](#).

**TI E2E™ Online Community** *TI's Engineer-to-Engineer (E2E) Community*. Created to foster collaboration among engineers. At e2e.ti.com, you can ask questions, share knowledge, explore ideas and help solve problems with fellow engineers.

**Design Support** *TI's Design Support* Quickly find helpful E2E forums along with design support tools and contact information for technical support.

## 12.6 Trademarks

E2E is a trademark of Texas Instruments.  
All other trademarks are the property of their respective owners.

## 12.7 Electrostatic Discharge Caution



This integrated circuit can be damaged by ESD. Texas Instruments recommends that all integrated circuits be handled with appropriate precautions. Failure to observe proper handling and installation procedures can cause damage.

ESD damage can range from subtle performance degradation to complete device failure. Precision integrated circuits may be more susceptible to damage because very small parametric changes could cause the device not to meet its published specifications.

## 12.8 Glossary

[SLYZ022](#) — *TI Glossary*.

This glossary lists and explains terms, acronyms, and definitions.

## 13 Mechanical, Packaging, and Orderable Information

The following pages include mechanical, packaging, and orderable information. This information is the most current data available for the designated devices. This data is subject to change without notice and revision of this document. For browser-based versions of this data sheet, refer to the left-hand navigation.

**PACKAGING INFORMATION**

Orderable part number	Status (1)	Material type (2)	Package   Pins	Package qty   Carrier	RoHS (3)	Lead finish/ Ball material (4)	MSL rating/ Peak reflow (5)	Op temp (°C)	Part marking (6)
<a href="#">TLV8541DBVR</a>	Active	Production	SOT-23 (DBV)   5	3000   LARGE T&R	Yes	NIPDAU   SN	Level-1-260C-UNLIM	-40 to 125	1D5L
TLV8541DBVR.B	Active	Production	SOT-23 (DBV)   5	3000   LARGE T&R	Yes	NIPDAU	Level-1-260C-UNLIM	-40 to 125	1D5L
<a href="#">TLV8542DR</a>	Active	Production	SOIC (D)   8	2500   LARGE T&R	Yes	NIPDAU	Level-1-260C-UNLIM	-40 to 125	TL8542
TLV8542DR.B	Active	Production	SOIC (D)   8	2500   LARGE T&R	Yes	NIPDAU	Level-1-260C-UNLIM	-40 to 125	TL8542
TLV8542DRG4	Active	Production	SOIC (D)   8	2500   LARGE T&R	Yes	NIPDAU	Level-1-260C-UNLIM	-40 to 125	TL8542
TLV8542DRG4.B	Active	Production	SOIC (D)   8	2500   LARGE T&R	Yes	NIPDAU	Level-1-260C-UNLIM	-40 to 125	TL8542
<a href="#">TLV8542RUGR</a>	Active	Production	X2QFN (RUG)   8	3000   LARGE T&R	Yes	NIPDAUAG	Level-1-260C-UNLIM	-40 to 125	AR
TLV8542RUGR.B	Active	Production	X2QFN (RUG)   8	3000   LARGE T&R	Yes	NIPDAUAG	Level-1-260C-UNLIM	-40 to 125	AR
<a href="#">TLV8544DR</a>	Active	Production	SOIC (D)   14	2500   LARGE T&R	Yes	NIPDAU	Level-1-260C-UNLIM	-40 to 125	TLV8544
TLV8544DR.B	Active	Production	SOIC (D)   14	2500   LARGE T&R	Yes	NIPDAU	Level-1-260C-UNLIM	-40 to 125	TLV8544
<a href="#">TLV8544DT</a>	Active	Production	SOIC (D)   14	250   SMALL T&R	Yes	NIPDAU	Level-1-260C-UNLIM	-40 to 125	TLV8544
TLV8544DT.B	Active	Production	SOIC (D)   14	250   SMALL T&R	Yes	NIPDAU	Level-1-260C-UNLIM	-40 to 125	TLV8544
<a href="#">TLV8544PWR</a>	Active	Production	TSSOP (PW)   14	2000   LARGE T&R	Yes	NIPDAU   SN	Level-1-260C-UNLIM	-40 to 125	TL8544
TLV8544PWR.B	Active	Production	TSSOP (PW)   14	2000   LARGE T&R	Yes	NIPDAU	Level-1-260C-UNLIM	-40 to 125	TL8544

(1) **Status:** For more details on status, see our [product life cycle](#).

(2) **Material type:** When designated, preproduction parts are prototypes/experimental devices, and are not yet approved or released for full production. Testing and final process, including without limitation quality assurance, reliability performance testing, and/or process qualification, may not yet be complete, and this item is subject to further changes or possible discontinuation. If available for ordering, purchases will be subject to an additional waiver at checkout, and are intended for early internal evaluation purposes only. These items are sold without warranties of any kind.

(3) **RoHS values:** Yes, No, RoHS Exempt. See the [TI RoHS Statement](#) for additional information and value definition.

(4) **Lead finish/Ball material:** Parts may have multiple material finish options. Finish options are separated by a vertical ruled line. Lead finish/Ball material values may wrap to two lines if the finish value exceeds the maximum column width.

(5) **MSL rating/Peak reflow:** The moisture sensitivity level ratings and peak solder (reflow) temperatures. In the event that a part has multiple moisture sensitivity ratings, only the lowest level per JEDEC standards is shown. Refer to the shipping label for the actual reflow temperature that will be used to mount the part to the printed circuit board.

(6) **Part marking:** There may be an additional marking, which relates to the logo, the lot trace code information, or the environmental category of the part.

Multiple part markings will be inside parentheses. Only one part marking contained in parentheses and separated by a "~" will appear on a part. If a line is indented then it is a continuation of the previous line and the two combined represent the entire part marking for that device.

**Important Information and Disclaimer:** The information provided on this page represents TI's knowledge and belief as of the date that it is provided. TI bases its knowledge and belief on information provided by third parties, and makes no representation or warranty as to the accuracy of such information. Efforts are underway to better integrate information from third parties. TI has taken and continues to take reasonable steps to provide representative and accurate information but may not have conducted destructive testing or chemical analysis on incoming materials and chemicals. TI and TI suppliers consider certain information to be proprietary, and thus CAS numbers and other limited information may not be available for release.

In no event shall TI's liability arising out of such information exceed the total purchase price of the TI part(s) at issue in this document sold by TI to Customer on an annual basis.

**TAPE AND REEL INFORMATION**

**QUADRANT ASSIGNMENTS FOR PIN 1 ORIENTATION IN TAPE**

\*All dimensions are nominal

Device	Package Type	Package Drawing	Pins	SPQ	Reel Diameter (mm)	Reel Width W1 (mm)	A0 (mm)	B0 (mm)	K0 (mm)	P1 (mm)	W (mm)	Pin1 Quadrant
TLV8541DBVR	SOT-23	DBV	5	3000	178.0	8.4	3.2	3.2	1.4	4.0	8.0	Q3
TLV8542DR	SOIC	D	8	2500	330.0	12.4	6.4	5.2	2.1	8.0	12.0	Q1
TLV8542DRG4	SOIC	D	8	2500	330.0	12.4	6.4	5.2	2.1	8.0	12.0	Q1
TLV8542RUGR	X2QFN	RUG	8	3000	180.0	8.4	1.6	1.6	0.66	4.0	8.0	Q2
TLV8544DR	SOIC	D	14	2500	330.0	16.4	6.5	9.0	2.1	8.0	16.0	Q1
TLV8544PWR	TSSOP	PW	14	2000	330.0	12.4	6.9	5.6	1.6	8.0	12.0	Q1

**TAPE AND REEL BOX DIMENSIONS**

\*All dimensions are nominal

Device	Package Type	Package Drawing	Pins	SPQ	Length (mm)	Width (mm)	Height (mm)
TLV8541DBVR	SOT-23	DBV	5	3000	208.0	191.0	35.0
TLV8542DR	SOIC	D	8	2500	340.5	338.1	20.6
TLV8542DRG4	SOIC	D	8	2500	340.5	338.1	20.6
TLV8542RUGR	X2QFN	RUG	8	3000	183.0	183.0	20.0
TLV8544DR	SOIC	D	14	2500	340.5	336.1	32.0
TLV8544PWR	TSSOP	PW	14	2000	356.0	356.0	35.0



# D0014A

# PACKAGE OUTLINE

## SOIC - 1.75 mm max height

SMALL OUTLINE INTEGRATED CIRCUIT



4220718/A 09/2016

### NOTES:

1. All linear dimensions are in millimeters. Dimensions in parenthesis are for reference only. Dimensioning and tolerancing per ASME Y14.5M.
2. This drawing is subject to change without notice.
3. This dimension does not include mold flash, protrusions, or gate burrs. Mold flash, protrusions, or gate burrs shall not exceed 0.15 mm, per side.
4. This dimension does not include interlead flash. Interlead flash shall not exceed 0.43 mm, per side.
5. Reference JEDEC registration MS-012, variation AB.

# EXAMPLE BOARD LAYOUT

D0014A

SOIC - 1.75 mm max height

SMALL OUTLINE INTEGRATED CIRCUIT



LAND PATTERN EXAMPLE  
SCALE:8X



SOLDER MASK DETAILS

4220718/A 09/2016

NOTES: (continued)

- 6. Publication IPC-7351 may have alternate designs.
- 7. Solder mask tolerances between and around signal pads can vary based on board fabrication site.

# EXAMPLE STENCIL DESIGN

D0014A

SOIC - 1.75 mm max height

SMALL OUTLINE INTEGRATED CIRCUIT



SOLDER PASTE EXAMPLE  
BASED ON 0.125 mm THICK STENCIL  
SCALE:8X

4220718/A 09/2016

NOTES: (continued)

8. Laser cutting apertures with trapezoidal walls and rounded corners may offer better paste release. IPC-7525 may have alternate design recommendations.
9. Board assembly site may have different recommendations for stencil design.



RUG (R-PQFP-N8)

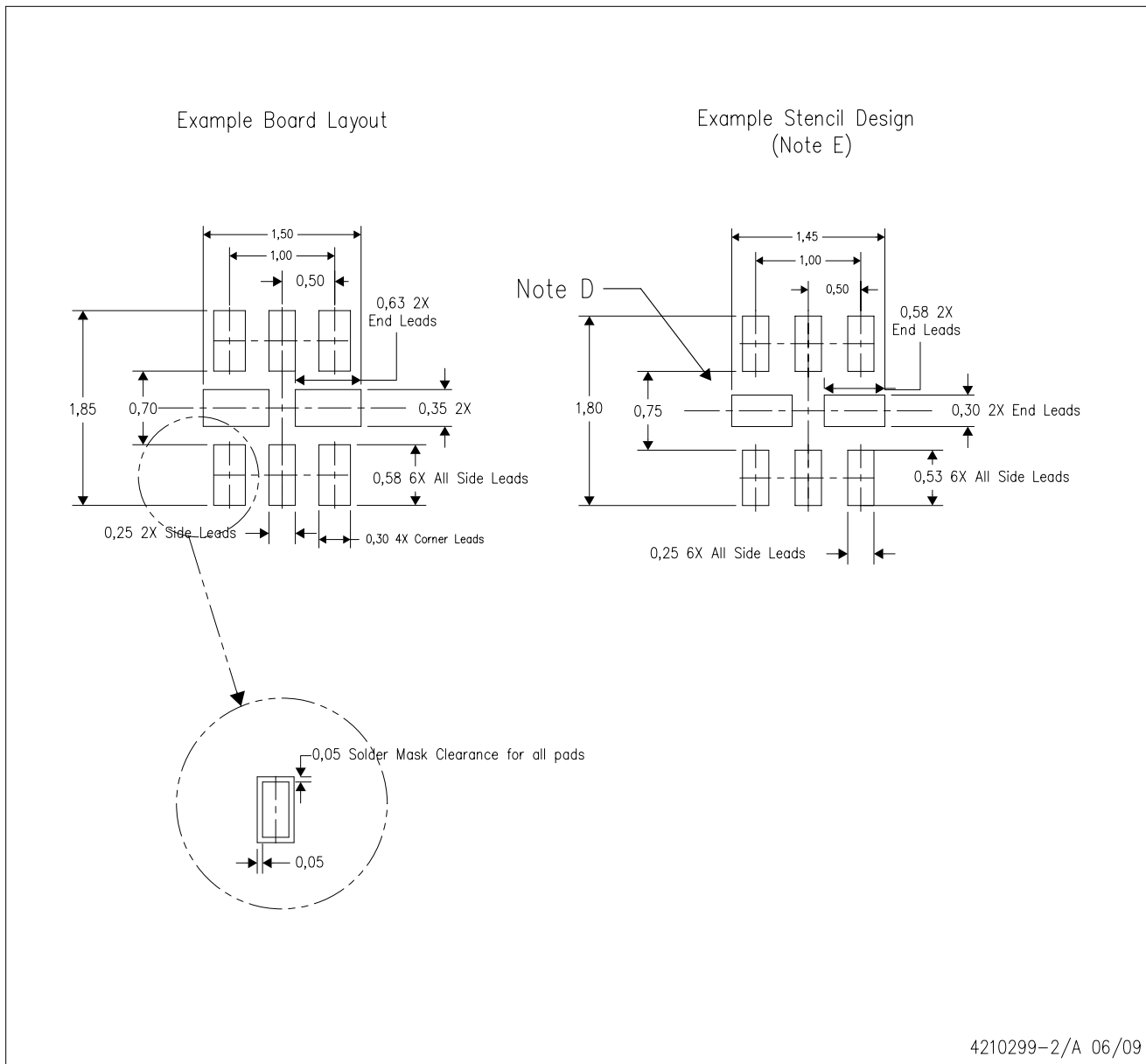

4210299-2/A 06/09

- NOTES:
- A. All linear dimensions are in millimeters.
  - B. This drawing is subject to change without notice.
  - C. Publication IPC-7351 is recommended for alternate designs.
  - D. Customers should contact their board fabrication site for minimum solder mask web tolerances between signal pads.
  - E. Maximum stencil thickness 0,127 mm (5 mils). All linear dimensions are in millimeters.
  - F. Laser cutting apertures with trapezoidal walls and also rounding corners will offer better paste release. Customers should contact their board assembly site for stencil design recommendations. Refer to IPC 7525 for stencil design considerations.
  - G. Side aperture dimensions over-print land for acceptable area ratio > 0.66. Customer may reduce side aperture dimensions if stencil manufacturing process allows for sufficient release at smaller opening.



D0008A

# PACKAGE OUTLINE

SOIC - 1.75 mm max height

SMALL OUTLINE INTEGRATED CIRCUIT



4214825/C 02/2019

NOTES:

- Linear dimensions are in inches [millimeters]. Dimensions in parenthesis are for reference only. Controlling dimensions are in inches. Dimensioning and tolerancing per ASME Y14.5M.
- This drawing is subject to change without notice.
- This dimension does not include mold flash, protrusions, or gate burrs. Mold flash, protrusions, or gate burrs shall not exceed  $.006$  [0.15] per side.
- This dimension does not include interlead flash.
- Reference JEDEC registration MS-012, variation AA.

# EXAMPLE BOARD LAYOUT

D0008A

SOIC - 1.75 mm max height

SMALL OUTLINE INTEGRATED CIRCUIT



LAND PATTERN EXAMPLE  
 EXPOSED METAL SHOWN  
 SCALE:8X



SOLDER MASK DETAILS

4214825/C 02/2019

NOTES: (continued)

- 6. Publication IPC-7351 may have alternate designs.
- 7. Solder mask tolerances between and around signal pads can vary based on board fabrication site.

# EXAMPLE STENCIL DESIGN

D0008A

SOIC - 1.75 mm max height

SMALL OUTLINE INTEGRATED CIRCUIT



SOLDER PASTE EXAMPLE  
BASED ON .005 INCH [0.125 MM] THICK STENCIL  
SCALE:8X

4214825/C 02/2019

NOTES: (continued)

8. Laser cutting apertures with trapezoidal walls and rounded corners may offer better paste release. IPC-7525 may have alternate design recommendations.
9. Board assembly site may have different recommendations for stencil design.

PW0014A



**PACKAGE OUTLINE**  
**TSSOP - 1.2 mm max height**

SMALL OUTLINE PACKAGE



4220202/B 12/2023

NOTES:

1. All linear dimensions are in millimeters. Any dimensions in parenthesis are for reference only. Dimensioning and tolerancing per ASME Y14.5M.
2. This drawing is subject to change without notice.
3. This dimension does not include mold flash, protrusions, or gate burrs. Mold flash, protrusions, or gate burrs shall not exceed 0.15 mm per side.
4. This dimension does not include interlead flash. Interlead flash shall not exceed 0.25 mm per side.
5. Reference JEDEC registration MO-153.

# EXAMPLE BOARD LAYOUT

PW0014A

TSSOP - 1.2 mm max height

SMALL OUTLINE PACKAGE



LAND PATTERN EXAMPLE  
EXPOSED METAL SHOWN  
SCALE: 10X



4220202/B 12/2023

NOTES: (continued)

- 6. Publication IPC-7351 may have alternate designs.
- 7. Solder mask tolerances between and around signal pads can vary based on board fabrication site.

# EXAMPLE STENCIL DESIGN

PW0014A

TSSOP - 1.2 mm max height

SMALL OUTLINE PACKAGE



SOLDER PASTE EXAMPLE  
BASED ON 0.125 mm THICK STENCIL  
SCALE: 10X

4220202/B 12/2023

NOTES: (continued)

8. Laser cutting apertures with trapezoidal walls and rounded corners may offer better paste release. IPC-7525 may have alternate design recommendations.
9. Board assembly site may have different recommendations for stencil design.



# EXAMPLE BOARD LAYOUT

DBV0005A

SOT-23 - 1.45 mm max height

SMALL OUTLINE TRANSISTOR



LAND PATTERN EXAMPLE  
EXPOSED METAL SHOWN  
SCALE:15X



SOLDER MASK DETAILS

4214839/K 08/2024

NOTES: (continued)

- 6. Publication IPC-7351 may have alternate designs.
- 7. Solder mask tolerances between and around signal pads can vary based on board fabrication site.

# EXAMPLE STENCIL DESIGN

DBV0005A

SOT-23 - 1.45 mm max height

SMALL OUTLINE TRANSISTOR



SOLDER PASTE EXAMPLE  
BASED ON 0.125 mm THICK STENCIL  
SCALE:15X

4214839/K 08/2024

NOTES: (continued)

8. Laser cutting apertures with trapezoidal walls and rounded corners may offer better paste release. IPC-7525 may have alternate design recommendations.
9. Board assembly site may have different recommendations for stencil design.

## IMPORTANT NOTICE AND DISCLAIMER

TI PROVIDES TECHNICAL AND RELIABILITY DATA (INCLUDING DATASHEETS), DESIGN RESOURCES (INCLUDING REFERENCE DESIGNS), APPLICATION OR OTHER DESIGN ADVICE, WEB TOOLS, SAFETY INFORMATION, AND OTHER RESOURCES "AS IS" AND WITH ALL FAULTS, AND DISCLAIMS ALL WARRANTIES, EXPRESS AND IMPLIED, INCLUDING WITHOUT LIMITATION ANY IMPLIED WARRANTIES OF MERCHANTABILITY, FITNESS FOR A PARTICULAR PURPOSE OR NON-INFRINGEMENT OF THIRD PARTY INTELLECTUAL PROPERTY RIGHTS.

These resources are intended for skilled developers designing with TI products. You are solely responsible for (1) selecting the appropriate TI products for your application, (2) designing, validating and testing your application, and (3) ensuring your application meets applicable standards, and any other safety, security, regulatory or other requirements.

These resources are subject to change without notice. TI grants you permission to use these resources only for development of an application that uses the TI products described in the resource. Other reproduction and display of these resources is prohibited. No license is granted to any other TI intellectual property right or to any third party intellectual property right. TI disclaims responsibility for, and you fully indemnify TI and its representatives against any claims, damages, costs, losses, and liabilities arising out of your use of these resources.

TI's products are provided subject to [TI's Terms of Sale](#), [TI's General Quality Guidelines](#), or other applicable terms available either on [ti.com](http://ti.com) or provided in conjunction with such TI products. TI's provision of these resources does not expand or otherwise alter TI's applicable warranties or warranty disclaimers for TI products. Unless TI explicitly designates a product as custom or customer-specified, TI products are standard, catalog, general purpose devices.

TI objects to and rejects any additional or different terms you may propose.

Copyright © 2026, Texas Instruments Incorporated

Last updated 10/2025