

TMUXS7614D 50V, SPI Controlled, Low-RON, High Density, 1:1 (SPST), 8-Channel Precision Switches with 1.8V Logic

1 Features

- Dual supply range: $\pm 4.5V$ to $\pm 25V$
- Single supply range: 4.5V to 42V
- Asymmetric dual supply support (For example: $V_{DD}=37.5V$, $V_{SS}=-12.5V$)
- [1.8V logic compatible](#)
- SPI supply range: 1.8V – 5.5V
- SPI Interface with support up to 50MHz
 - Manual mode (Standard SPI or Burst mode)
 - [Section 7.4.3](#)
 - SPI error detection: CRC, invalid read/write, and clock count error
 - Compatible with SPI industry standard modes 0 and 3
- Ultra high channel density ($2.5mm^2/ch$)
 - Flow through SPI and supply routing for increased board density
 - Integrated decoupling capacitors
- Precision performance:
 - Low on-resistance: 1Ω (typical)
 - [Ultra low on-resistance flatness](#): 0.001Ω (typical)
 - Low on-leakage current: $13pA$ (typical), $350pA$ (maximum)
 - Ultra low charge injection: $2pC$ (typical)
- High current support: $470mA$ per channel (maximum)
- $-40^\circ C$ to $+125^\circ C$ operating temperature
- [Rail-to-rail operation](#)
- [Bidirectional operation](#)
- Break-before-make switching
- ESD protection HBM: $3000V$

2 Applications

- [Semiconductor test equipment](#)
- SSR and photorelay replacement
- Automated test equipment
- LCD test equipment
- Memory test equipment
- [Instrumentation: lab, analytical, and portable](#)
- [Data acquisition systems \(DAQ\)](#)
- [Optical test equipment](#)

3 Description

The TMUXS7614D is a complementary metal-oxide semiconductor (CMOS) switch device with eight independently selectable 1:1, single-pole, single-throw (SPST) switch channels. The device works with a single supply (4.5V to 42V), dual supplies ($\pm 4.5V$ to $\pm 25V$), or asymmetric supplies (such as $V_{DD} = 37.5V$, $V_{SS} = -12V$). The TMUXS7614D supports bidirectional analog and digital signals on the source (Sx) and drain (Dx) pins ranging from V_{SS} to V_{DD} .

The switches of the TMUXS7614D are controlled with a serial peripheral interface (SPI). The SPI interface has many error detection features, such as CRC, invalid read/write, and clock count error detection. The SPI also supports Daisy Chain mode. Coupled with the flow through routing of the SPI pins, this allows for increased channel density in the system. The TMUXS7614D is a part of the precision switches and multiplexers family of devices that have very low on and off leakage currents allowing them to be used in high precision measurement applications.

Package Information

PART NUMBER	PACKAGE ⁽¹⁾ (3)	PACKAGE SIZE ⁽²⁾
TMUXS7614D	ZEM (FCLGA, 30)	5mm × 4mm

- (1) For more information, see [Section 11](#).
- (2) The package size (length × width) is a nominal value and includes pins, where applicable.
- (3) FCLGA packages have a recommended reflow profile, please see [Section 8.3](#) for more information

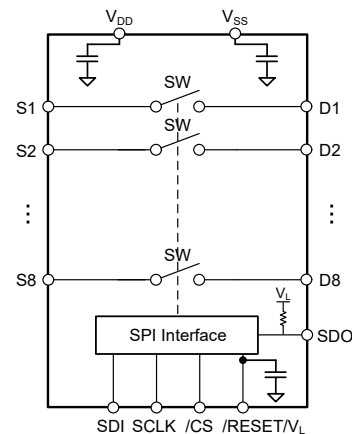

TMUXS7614D Block Diagrams



Table of Contents

1 Features	1	6.6 Charge Injection.....	24
2 Applications	1	6.7 Off Isolation.....	24
3 Description	1	6.8 Channel-to-Channel Crosstalk.....	25
4 Pin Configuration and Functions	3	6.9 Bandwidth.....	25
5 Specifications	4	6.10 THD + Noise.....	26
5.1 Absolute Maximum Ratings.....	4	7 Detailed Description	27
5.2 ESD Ratings.....	4	7.1 Overview.....	27
5.3 Thermal Information.....	5	7.2 Functional Block Diagram.....	27
5.4 Recommended Operating Conditions.....	5	7.3 Feature Description.....	27
5.5 Source or Drain Current through Switch.....	5	7.4 SPI Operation.....	28
5.6 Electrical Characteristics (Global).....	6	7.5 Device Functional Modes.....	29
5.7 Electrical Characteristics ($\pm 15\text{V}$ Dual Supply).....	7	7.6 Register Map.....	31
5.8 Switching Characteristics ($\pm 15\text{V}$ Dual Supply).....	8	8 Application and Implementation	32
5.9 Electrical Characteristics ($\pm 20\text{V}$ Dual Supply).....	9	8.1 Application Information.....	32
5.10 Switching Characteristics ($\pm 20\text{V}$ Dual Supply).....	10	8.2 Typical Application	32
5.11 Electrical Characteristics ($+37.5\text{V}/-12.5\text{V}$ Dual Supply).....	11	8.3 Recommended Reflow Profile.....	33
5.12 Switching Characteristics ($+37.5\text{V}/-12.5\text{V}$ Dual Supply).....	12	8.4 Thermal Considerations.....	34
5.13 Electrical Characteristics (12V Single Supply).....	13	8.5 Power Supply Recommendations.....	35
5.14 Switching Characteristics (12V Single Supply).....	14	8.6 Layout.....	36
5.15 SPI Timing Characteristics (2.7V to 5.5V).....	14	9 Device and Documentation Support	38
5.16 SPI Timing Characteristics (1.8V to 2.7V).....	15	9.1 Documentation Support.....	38
5.17 Timing Diagrams	16	9.2 Receiving Notification of Documentation Updates...38	
5.18 Typical Characteristics.....	17	9.3 Support Resources.....	38
6 Parameter Measurement Information	22	9.4 Trademarks.....	38
6.1 On-Resistance.....	22	9.5 Electrostatic Discharge Caution.....	38
6.2 Off-Leakage Current.....	22	9.6 Glossary.....	38
6.3 On-Leakage Current.....	23	10 Revision History	38
6.4 t_{ON} and t_{OFF} Time.....	23	11 Mechanical, Packaging, and Orderable Information	39
6.5 Break-Before-Make.....	24	11.1 Tape and Reel Information.....	39
		11.2 Mechanical Data.....	41

4 Pin Configuration and Functions

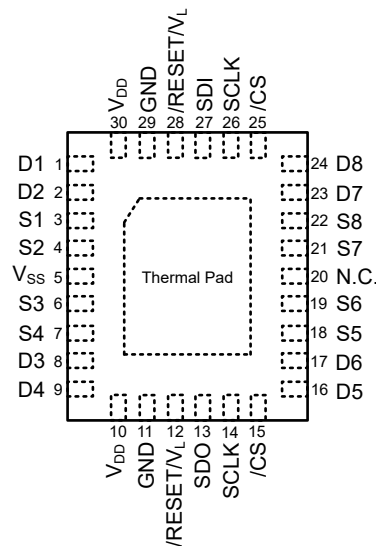

Figure 4-1. ZEM Package, 30-Pin LGA (Top View)

Table 4-1. Pin Functions

PIN		TYPE ⁽¹⁾	DESCRIPTION
NAME	NO.		
D1	1	I/O	Drain pin 1. Can be an input or output.
D2	2	I/O	Drain pin 2. Can be an input or output.
D3	8	I/O	Drain pin 3. Can be an input or output.
D4	9	I/O	Drain pin 4. Can be an input or output.
D5	16	I/O	Drain pin 5. Can be an input or output.
D6	17	I/O	Drain pin 6. Can be an input or output.
D7	23	I/O	Drain pin 7. Can be an input or output.
D8	24	I/O	Drain pin 8. Can be an input or output.
GND	11, 29	P	Ground (0V) reference. On TMUXS7614D, both GND pins are connected internally for flow through routing.
N.C.	20	-	No internal connection. Can be shorted to GND or left floating.
S1	3	I/O	Source pin 1. Can be an input or output.
S2	4	I/O	Source pin 2. Can be an input or output.
S3	6	I/O	Source pin 3. Can be an input or output.
S4	7	I/O	Source pin 4. Can be an input or output.
S5	18	I/O	Source pin 5. Can be an input or output.
S6	19	I/O	Source pin 6. Can be an input or output.
S7	21	I/O	Source pin 7. Can be an input or output.
S8	22	I/O	Source pin 8. Can be an input or output.
SDI	27	I	SPI Serial Data Input. Data is captured on the positive edge of SCLK.
SCLK	14, 26	I	SPI Clock Input. Both SCLK pins are connected internally for flow through routing.
SDO	13	O	SPI Serial Data Output. Data is shifted out on the negative edge of SCLK.
CS	15, 25	I	SPI Chip Select Pin (active low). Both CS pins are connected internally for flow through routing.
RESET/V _L	12, 28	P	SPI Power Supply pin (1.8V – 5.5V) and hardware reset pin (active low). Pull the pin low to trigger a device hardware reset. After the hardware reset is complete, the SPI registers will be reset to their default state, and all the analog switches will be open. Both RESET/V _L pins are connected internally for flow through routing. Connected to an integrated 0.1µF capacitor between V _L and GND.
VDD	10, 30	P	Positive power supply. This pin is the most positive power-supply potential. On TMUXS7614D, both VDD pins are connected internally for flow through routing. Connected to an integrated 0.1µF capacitor between VDD and GND.
VSS	5	P	Negative power supply. This pin is the most negative power-supply potential. In single-supply applications, this pin should be connected to ground. Connected to an integrated 0.1µF capacitor between VSS and GND.
Thermal Pad		—	The thermal exposed pad is connected internally. It is recommended that the pad be tied to VSS for best performance.

(1) I = input, O = output, I/O = input and output, P = power.

5 Specifications

5.1 Absolute Maximum Ratings

over operating free-air temperature range (unless otherwise noted)^{(1) (2)}

		MIN	MAX	UNIT
$V_{DD} - V_{SS}$	Supply voltage		50	V
V_{DD}		-0.5	50	V
V_{SS}		-32	0.5	V
V_L	Logic Supply Voltage	-0.5	6	V
V_{LOGIC}	Logic control input pin voltage (SPI pins)	-0.5	6	V
I_{LOGIC}	Logic control input pin current (SPI pins)	-30	30	mA
V_S or V_D	Source or drain voltage (Sx, Dx)	$V_{SS}-0.5$	$V_{DD}+0.5$	V
I_{IK}	Diode clamp current ⁽³⁾	-30	30	mA
I_S or I_D (CONT)	Source or drain continuous current (Sx, Dx)		$I_{DC} + 10\%$ ⁽⁴⁾	mA
T_A	Ambient temperature	-55	150	°C
T_{stg}	Storage temperature	-65	150	°C
T_J	Junction temperature		150	°C
P_{tot}	Total power dissipation		1650	mW

- (1) Operation outside the Absolute Maximum Ratings may cause permanent device damage. Absolute Maximum Ratings do not imply functional operation of the device at these or any other conditions beyond those listed under Recommended Operating Conditions. If used outside the Recommended Operating Conditions but within the Absolute Maximum Ratings, the device may not be fully functional, and this may affect device reliability, functionality, performance, and shorten the device lifetime.
- (2) All voltages are with respect to ground, unless otherwise specified.
- (3) Pins are diode-clamped to the power-supply rails. Over voltage signals must be voltage and current limited to maximum ratings.
- (4) Refer to *Source or Drain Continuous Current* table for I_{DC} specifications.

5.2 ESD Ratings

		VALUE	UNIT
$V_{(ESD)}$	Electrostatic discharge	Human body model (HBM), per ANSI/ESDA/ JEDEC JS-001, all pins ⁽¹⁾	±3000
		Charged device model (CDM), per ANSI/ESDA/ JEDEC JS-002, all pins ⁽²⁾	±1000

- (1) JEDEC document JEP155 states that 500V HBM allows safe manufacturing with a standard ESD control process.
- (2) JEDEC document JEP157 states that 250V CDM allows safe manufacturing with a standard ESD control process.

5.3 Thermal Information

THERMAL METRIC ⁽¹⁾		TMUXS7614D	
		ZEM (LGA)	
		30 PINS	
			UNIT
R _{θJA}	Junction-to-ambient thermal resistance	53.5	°C/W
R _{θJC(top)}	Junction-to-case (top) thermal resistance	15.9	°C/W
R _{θJB}	Junction-to-board thermal resistance	28.2	°C/W
Ψ _{JT}	Junction-to-top characterization parameter	0.30	°C/W
Ψ _{JB}	Junction-to-board characterization parameter	27.8	°C/W
R _{θJC(bot)}	Junction-to-case (bottom) thermal resistance	41.0	°C/W

(1) For more information about traditional and new thermal metrics, see the [Semiconductor and IC Package Thermal Metrics](#) application note.

5.4 Recommended Operating Conditions

over operating free-air temperature range (unless otherwise noted)

		MIN	NOM	MAX	UNIT
V _{DD} – V _{SS} ⁽¹⁾	Power supply voltage differential	4.5		50	V
V _{DD}	Positive power supply voltage	4.5		42	V
V _S or V _D	Signal path input/output voltage (source or drain pin) (Sx, D)	V _{SS}		V _{DD}	V
V _L	Logic Supply Voltage	1.8		5.5	V
V _{LOGIC}	Logic control input pin voltage (SPI pins)	0		5.5	V
I _S or I _{D (CONT)}	Source or drain continuous current (Sx, D)			I _{DC} ⁽²⁾	mA
T _A	Ambient temperature	–40		125	°C

(1) V_{DD} and V_{SS} can be any value within maximum recommended operating conditions as long as 4.5V ≤ (V_{DD} – V_{SS}) ≤ 44V and the minimum V_{DD} is met.

(2) Refer to *Source or Drain Continuous Current* table for I_{DC} specifications.

5.5 Source or Drain Current through Switch

Current through the Switch	Test Conditions	Temperature (T _J)							UNIT
		25°C	50°C	85°C	105°C	125°C	135°C	150°C	
I _{DC} ⁽¹⁾	V _{SS} to V _{DD} - 2.5V	470	470	470	309	143	100	60	mA
I _{peak} ⁽²⁾	V _{SS} to V _{DD} - 2.5V	470	470	470	470	470	470	470	mA

(1) See [Section 8.4](#) for more details

(2) Pulse current of 1ms with 10% Duty Cycle

5.6 Electrical Characteristics (Global)

Over operating supply voltage range, $V_L = 1.8V - 5.5V$, $GND = 0V$ (unless otherwise noted)

Typical at $V_{DD} = +15V$, $V_{SS} = -15V$, $V_L = 3.3V$, $T_A = 25^\circ C$ (unless otherwise noted)

PARAMETER		TEST CONDITIONS	T_A	MIN	TYP	MAX	UNIT
LOGIC INPUTS (SPI pins)							
V_{IH}	Logic voltage high	$V_L = 5.5V$	$-40^\circ C$ to $+125^\circ C$	2			V
		$V_L = 3.3V$	$-40^\circ C$ to $+125^\circ C$	1.35			V
		$V_L \leq 1.8V$	$-40^\circ C$ to $+125^\circ C$	1			V
V_{IL}	Logic voltage low	$2.7V \leq V_L \leq 5.5V$	$-40^\circ C$ to $+125^\circ C$			0.75	V
		$1.8V \leq V_L < 2.7V$	$-40^\circ C$ to $+125^\circ C$			0.5	V
I_{IH}	Input leakage current		$-40^\circ C$ to $+125^\circ C$	0.005		2	μA
I_{IL}	Input leakage current		$-40^\circ C$ to $+125^\circ C$	-2	-0.005		μA
T_{SD}	Thermal shutdown			165			$^\circ C$
T_{SD_HYST}	Thermal shutdown hysteresis			15			$^\circ C$
V_{OH}	Logic high output voltage	$I_{SOURCE} = 100\mu A$	$-40^\circ C$ to $+125^\circ C$	$V_L - 0.1$			V
		$I_{SOURCE} = 1mA$	$-40^\circ C$ to $+125^\circ C$	$V_L - 0.7$			V
V_{OL}	Logic low output voltage	$I_{SINK} = 100\mu A$	$-40^\circ C$ to $+125^\circ C$			0.1	V
		$I_{SINK} = 1mA$	$-40^\circ C$ to $+125^\circ C$			0.7	V
C_{IN}	Logic input capacitance		$-40^\circ C$ to $+125^\circ C$	3.5			pF
POWER SUPPLY							
I_{LQ}	V_L quiescent supply current	$V_L = 1.8V$ to $5.5V$ SPI Inputs = $0V$ or V_L	$25^\circ C$	5		6	μA
			$-40^\circ C$ to $+85^\circ C$			7	μA
			$-40^\circ C$ to $+125^\circ C$			8	μA
I_L	V_L active supply current	$V_L = 2.7V$ to $5.5V$ /CS = $0V$, fSCLK = $50MHz$, fSDI = $25MHz$	$25^\circ C$	1		1.2	mA
			$-40^\circ C$ to $+85^\circ C$			1.5	mA
			$-40^\circ C$ to $+125^\circ C$			2	mA

5.7 Electrical Characteristics (±15V Dual Supply)

$V_{DD} = +15V \pm 10\%$, $V_{SS} = -15V \pm 10\%$ GND = 0V (unless otherwise noted)

Typical at $V_{DD} = +15V$, $V_{SS} = -15V$, $T_A = 25^\circ C$ (unless otherwise noted)

PARAMETER		TEST CONDITIONS	T_A	MIN	TYP	MAX	UNIT
ANALOG SWITCH							
R_{ON}	On-resistance	$V_S = -10V$ to $+10V$ $I_D = -10mA$	25°C	1	1.4		Ω
			-40°C to +50°C		1.6		
			-40°C to +85°C		1.8		
			-40°C to +125°C		2.2		
ΔR_{ON}	On-resistance mismatch between channels	$V_S = -10V$ to $+10V$ $I_D = -10mA$	25°C	0.015			Ω
			-40°C to +50°C		0.030		
			-40°C to +85°C		0.035		
			-40°C to +125°C		0.040		
$R_{ON\ FLAT}$	On-resistance flatness	$V_S = -10V$ to $+10V$ $I_D = -10mA$	25°C	0.001			Ω
			-40°C to +50°C		0.035		
			-40°C to +85°C		0.040		
			-40°C to +125°C		0.045		
$R_{ON\ DRIFT}$	On-resistance drift	$V_S = 0V$, $I_S = -10mA$	-40°C to +125°C	0.006			$\Omega/^\circ C$
$I_{S(OFF)}$	Source off leakage current ⁽¹⁾	$V_{DD} = 16.5V$, $V_{SS} = -16.5V$ Switch state is off $V_S = +10V / -10V$ $V_D = -10V / +10V$	25°C	-0.35	0.030	0.35	nA
			-40°C to +50°C	-0.45		0.45	
			-40°C to +85°C	-3		3	
$I_{D(OFF)}$	Drain off leakage current ⁽¹⁾	$V_{DD} = 16.5V$, $V_{SS} = -16.5V$ Switch state is off $V_S = +10V / -10V$ $V_D = -10V / +10V$	25°C	-0.35	0.030	0.35	nA
			-40°C to +50°C	-0.45		0.45	
			-40°C to +85°C	-3		3	
$I_{S(ON)}$ $I_{D(ON)}$	Channel on leakage current ⁽²⁾	$V_{DD} = 16.5V$, $V_{SS} = -16.5V$ Switch state is on $V_S = V_D = \pm 10V$	25°C	-0.35	0.013	0.35	nA
			-40°C to +50°C	-0.45		0.45	
			-40°C to +85°C	-2		2	
POWER SUPPLY							
I_{DDQ}	V_{DD} quiescent supply current	$V_{DD} = 16.5V$, $V_{SS} = -16.5V$ All switches OFF	25°C	45	80		μA
			-40°C to +85°C		90		
			-40°C to +125°C		115		
I_{DD}	V_{DD} supply current	$V_{DD} = 16.5V$, $V_{SS} = -16.5V$ All switches ON	25°C	840	1110		μA
			-40°C to +85°C		1120		
			-40°C to +125°C		1125		
I_{SSQ}	V_{SS} quiescent supply current	$V_{DD} = 16.5V$, $V_{SS} = -16.5V$ All switches OFF	25°C	15	30		μA
			-40°C to +85°C		45		
			-40°C to +125°C		65		
I_{SS}	V_{SS} supply current	$V_{DD} = 16.5V$, $V_{SS} = -16.5V$ All switches ON	25°C	680	800		μA
			-40°C to +85°C		850		
			-40°C to +125°C		900		

(1) When V_S is positive, V_D is negative, or when V_S is negative, V_D is positive.

(2) When V_S is at a voltage potential, V_D is floating, or when V_D is at a voltage potential, V_S is floating.

5.8 Switching Characteristics (±15V Dual Supply)

$V_{DD} = +15V \pm 10\%$, $V_{SS} = -15V \pm 10\%$, GND = 0V (unless otherwise noted)

Typical at $V_{DD} = +15V$, $V_{SS} = -15V$, $T_A = 25^\circ C$ (unless otherwise noted)

PARAMETER		TEST CONDITIONS	T_A	MIN	TYP	MAX	UNIT
t_{ON}	Turn-on time from control input	$V_S = 10V$ $R_L = 300\Omega$, $C_L = 35pF$	25°C		2.0	2.5	μs
			-40°C to +85°C			2.75	μs
			-40°C to +125°C			3	μs
t_{OFF}	Turn-off time from control input	$V_S = 10V$ $R_L = 300\Omega$, $C_L = 35pF$	25°C		1.7	2.2	μs
			-40°C to +85°C			2.5	μs
			-40°C to +125°C			3	μs
t_{BBM}	Break-before-make time delay	$V_S = 10V$, $R_L = 300\Omega$, $C_L = 35pF$	25°C		310		ns
			-40°C to +85°C		125		ns
			-40°C to +125°C		125		ns
Q_{INJ}	Charge injection	$V_S = 0V$, $C_L = 100pF$	25°C		-2		pC
O_{ISO}	Off-isolation	$R_L = 50\Omega$, $C_L = 5pF$ $V_S = 200mV_{RMS}$, $V_{BIAS} = 0V$, $f = 100kHz$	25°C		-97		dB
O_{ISO}	Off-isolation	$R_L = 50\Omega$, $C_L = 5pF$ $V_S = 200mV_{RMS}$, $V_{BIAS} = 0V$, $f = 1MHz$	25°C		-71		dB
X_{TALK}	Crosstalk	$R_L = 50\Omega$, $C_L = 5pF$ $V_S = 200mV_{RMS}$, $V_{BIAS} = 0V$, $f = 100kHz$	25°C		-110		dB
X_{TALK}	Crosstalk	$R_L = 50\Omega$, $C_L = 5pF$ $V_S = 200mV_{RMS}$, $V_{BIAS} = 0V$, $f = 1MHz$	25°C		-105		dB
BW	-3dB Bandwidth	$R_L = 50\Omega$, $C_L = 5pF$ $V_S = 200mV_{RMS}$, $V_{BIAS} = 0V$	25°C		180		MHz
I_L	Insertion loss	$R_L = 50\Omega$, $C_L = 5pF$ $V_S = 200mV_{RMS}$, $V_{BIAS} = 0V$, $f = 1MHz$	25°C		-0.082		dB
ACPSRR	AC Power Supply Rejection Ratio	$V_{PP} = 0.62V$ on V_{DD} and V_{SS} $R_L = 50\Omega$, $C_L = 5pF$, $f = 1MHz$	25°C		-70		dB
THD+N	Total Harmonic Distortion + Noise	$V_{PP} = 15V$, $V_{BIAS} = 0V$ $R_L = 110\Omega$, $C_L = 5pF$, $f = 20Hz$ to 20kHz	25°C		0.0005		%
$C_{S(OFF)}$	Source off capacitance to ground	$V_S = 0V$, $f = 1MHz$	25°C		27		pF
$C_{D(OFF)}$	Drain off capacitance to ground	$V_S = 0V$, $f = 1MHz$	25°C		27		pF
$C_{S(ON)}$, $C_{D(ON)}$	On capacitance to ground	$V_S = 0V$, $f = 1MHz$	25°C		28		pF

5.9 Electrical Characteristics (±20V Dual Supply)

$V_{DD} = +20V \pm 10\%$, $V_{SS} = -20V \pm 10\%$, GND = 0V (unless otherwise noted)

Typical at $V_{DD} = +20V$, $V_{SS} = -20V$, $T_A = 25^\circ C$ (unless otherwise noted)

PARAMETER		TEST CONDITIONS	T_A	MIN	TYP	MAX	UNIT
ANALOG SWITCH							
R_{ON}	On-resistance	$V_S = -15V$ to $+15V$ $I_D = -10mA$	25°C		1	1.4	Ω
			-40°C to +50°C			1.6	
			-40°C to +85°C			1.9	
			-40°C to +125°C			2.2	
ΔR_{ON}	On-resistance mismatch between channels	$V_S = -15V$ to $+15V$ $I_D = -10mA$	25°C		0.015		Ω
			-40°C to +50°C			0.038	
			-40°C to +85°C			0.048	
			-40°C to +125°C			0.050	
$R_{ON\ FLAT}$	On-resistance flatness	$V_S = -15V$ to $+15V$ $I_D = -10mA$	25°C		0.001		Ω
			-40°C to +50°C			0.030	
			-40°C to +85°C			0.035	
			-40°C to +125°C			0.040	
$R_{ON\ DRIFT}$	On-resistance drift	$V_S = 0V$, $I_S = -10mA$	-40°C to +125°C		0.005		$\Omega/^\circ C$
$I_{S(OFF)}$	Source off leakage current ⁽¹⁾	$V_{DD} = 22V$, $V_{SS} = -22V$ Switch state is off $V_S = +15V / -15V$ $V_D = -15V / +15V$	25°C	-0.4	0.012	0.4	nA
			-40°C to +50°C			0.75	
			-40°C to +85°C			4	
$I_{D(OFF)}$	Drain off leakage current ⁽¹⁾	$V_{DD} = 22V$, $V_{SS} = -22V$ Switch state is off $V_S = +15V / -15V$ $V_D = -15V / +15V$	25°C	-0.4	0.012	0.4	nA
			-40°C to +50°C			0.75	
			-40°C to +85°C			4	
$I_{S(ON)}$ $I_{D(ON)}$	Channel on leakage current ⁽²⁾	$V_{DD} = 22V$, $V_{SS} = -22V$ Switch state is on $V_S = V_D = \pm 15V$	25°C	-0.35	0.004	0.35	nA
			-40°C to +50°C			0.6	
			-40°C to +85°C			1.6	
POWER SUPPLY							
I_{DDQ}	V_{DD} quiescent supply current	$V_{DD} = 22V$, $V_{SS} = -22V$ All switches OFF	25°C		45	80	μA
			-40°C to +85°C			90	
			-40°C to +125°C			115	
I_{DD}	V_{DD} supply current	$V_{DD} = 22V$, $V_{SS} = -22V$ All switches ON	25°C		840	1110	μA
			-40°C to +85°C			1120	
			-40°C to +125°C			1125	
I_{SSQ}	V_{SS} quiescent supply current	$V_{DD} = 22V$, $V_{SS} = -22V$ All switches OFF	25°C		15	30	μA
			-40°C to +85°C			45	
			-40°C to +125°C			65	
I_{SS}	V_{SS} supply current	$V_{DD} = 22V$, $V_{SS} = -22V$ All switches ON	25°C		680	800	μA
			-40°C to +85°C			850	
			-40°C to +125°C			900	

(1) When V_S is positive, V_D is negative, or when V_S is negative, V_D is positive.

(2) When V_S is at a voltage potential, V_D is floating, or when V_D is at a voltage potential, V_S is floating.

5.10 Switching Characteristics (±20V Dual Supply)

$V_{DD} = +20V \pm 10\%$, $V_{SS} = -20V \pm 10\%$, GND = 0V (unless otherwise noted)

Typical at $V_{DD} = +20V$, $V_{SS} = -20V$, $T_A = 25^\circ C$ (unless otherwise noted)

PARAMETER		TEST CONDITIONS	T_A	MIN	TYP	MAX	UNIT
t_{ON}	Turn-on time from control input	$V_S = 10V$ $R_L = 300\Omega$, $C_L = 35pF$	25°C		2	2.5	μs
			-40°C to +85°C			2.9	μs
			-40°C to +125°C			3	μs
t_{OFF}	Turn-off time from control input	$V_S = 10V$ $R_L = 300\Omega$, $C_L = 35pF$	25°C		1.8	2.2	μs
			-40°C to +85°C			2.5	μs
			-40°C to +125°C			2.8	μs
t_{BBM}	Break-before-make time delay	$V_S = 10V$, $R_L = 300\Omega$, $C_L = 35pF$	25°C		320		ns
			-40°C to +85°C		150		ns
			-40°C to +125°C		150		ns
Q_{INJ}	Charge injection	$V_S = 0V$, $C_L = 100pF$	25°C		-3		pC
O_{ISO}	Off-isolation	$R_L = 50\Omega$, $C_L = 5pF$ $V_S = 200mV_{RMS}$, $V_{BIAS} = 0V$, $f = 100kHz$	25°C		-96		dB
O_{ISO}	Off-isolation	$R_L = 50\Omega$, $C_L = 5pF$ $V_S = 200mV_{RMS}$, $V_{BIAS} = 0V$, $f = 1MHz$	25°C		-73		dB
X_{TALK}	Crosstalk	$R_L = 50\Omega$, $C_L = 5pF$ $V_S = 200mV_{RMS}$, $V_{BIAS} = 0V$, $f = 100kHz$	25°C		-106		dB
X_{TALK}	Crosstalk	$R_L = 50\Omega$, $C_L = 5pF$ $V_S = 200mV_{RMS}$, $V_{BIAS} = 0V$, $f = 1MHz$	25°C		-105		dB
BW	-3dB Bandwidth	$R_L = 50\Omega$, $C_L = 5pF$ $V_S = 200mV_{RMS}$, $V_{BIAS} = 0V$,	25°C		190		MHz
I_L	Insertion loss	$R_L = 50\Omega$, $C_L = 5pF$ $V_S = 200mV_{RMS}$, $V_{BIAS} = 0V$, $f = 1MHz$	25°C		-0.082		dB
ACPSRR	AC Power Supply Rejection Ratio	$V_{PP} = 0.62V$ on V_{DD} and V_{SS} $R_L = 50\Omega$, $C_L = 5pF$, $f = 1MHz$	25°C		-65		dB
THD+N	Total Harmonic Distortion + Noise	$V_{PP} = 20V$, $V_{BIAS} = 0V$ $R_L = 110\Omega$, $C_L = 5pF$, $f = 20Hz$ to 20kHz	25°C		0.0004		%
$C_{S(OFF)}$	Source off capacitance to ground	$V_S = 0V$, $f = 1MHz$	25°C		24		pF
$C_{D(OFF)}$	Drain off capacitance to ground	$V_S = 0V$, $f = 1MHz$	25°C		24		pF
$C_{S(ON)}$, $C_{D(ON)}$	On capacitance to ground	$V_S = 0V$, $f = 1MHz$	25°C		27		pF

5.11 Electrical Characteristics (+37.5V/–12.5V Dual Supply)

$V_{DD} = +37.5V - 10\%$, $V_{SS} = -12.5V - 10\%$, $GND = 0V$ (unless otherwise noted)

$V_{DD} = +37.5V - 10\%$, $V_{SS} = -12.5V$, $T_A = 25^\circ C$ (unless otherwise noted)

PARAMETER		TEST CONDITIONS	T_A	MIN	TYP	MAX	UNIT
ANALOG SWITCH							
R_{ON}	On-resistance	$V_S = -7.5V$ to $32.5V$ $I_D = -10mA$	25°C	1	1.35		Ω
			–40°C to +50°C		1.6		
			–40°C to +85°C		1.8		
			–40°C to +125°C		2.1		
ΔR_{ON}	On-resistance mismatch between channels	$V_S = -7.5V$ to $32.5V$ $I_D = -10mA$	25°C	0.015			Ω
			–40°C to +50°C		0.038		
			–40°C to +85°C		0.048		
			–40°C to +125°C		0.050		
$R_{ON\ FLAT}$	On-resistance flatness	$V_S = -7.5V$ to $32.5V$ $I_D = -10mA$	25°C	0.001			Ω
			–40°C to +50°C		0.02		
			–40°C to +85°C		0.03		
			–40°C to +125°C		0.04		
$R_{ON\ DRIFT}$	On-resistance drift	$V_S = 0V$, $I_S = -10mA$	–40°C to +125°C	0.006			$\Omega/^\circ C$
$I_{S(OFF)}$	Source off leakage current ⁽¹⁾	$V_{DD} = 37.5V$, $V_{SS} = -12.5V$ Switch state is off $V_S = 32.5V / -7.5V$ $V_D = -7.5V / 32.5V$	25°C	–0.3	0.021	0.3	nA
			–40°C to +50°C	–0.75		0.75	
			–40°C to +85°C	–5		5	
$I_{D(OFF)}$	Drain off leakage current ⁽¹⁾	$V_{DD} = 37.5V$, $V_{SS} = -12.5V$ Switch state is off $V_S = 32.5V / -7.5V$ $V_D = -7.5V / 32.5V$	25°C	–0.3	0.021	0.3	nA
			–40°C to +50°C	–0.75		0.75	
			–40°C to +85°C	–5		5	
$I_{S(ON)}$ $I_{D(ON)}$	Channel on leakage current ⁽²⁾	$V_{DD} = 37.5V$, $V_{SS} = -12.5V$ Switch state is on $V_S = V_D = 32.5V$ or $-7.5V$	25°C	–0.35	0.020	0.35	nA
			–40°C to +50°C	–0.6		0.6	
			–40°C to +85°C	–2		2	
POWER SUPPLY							
I_{DDQ}	V_{DD} quiescent supply current	$V_{DD} = 37.5V$, $V_{SS} = -12.5V$ All switches OFF	25°C	45		80	μA
			–40°C to +85°C			95	
			–40°C to +125°C			120	
I_{DD}	V_{DD} supply current	$V_{DD} = 37.5V$, $V_{SS} = -12.5V$ All switches ON	25°C	840		1110	μA
			–40°C to +85°C			1120	
			–40°C to +125°C			1125	
I_{SSQ}	V_{SS} quiescent supply current	$V_{DD} = 37.5V$, $V_{SS} = -12.5V$ All switches OFF	25°C	17		30	μA
			–40°C to +85°C			45	
			–40°C to +125°C			65	
I_{SS}	V_{SS} supply current	$V_{DD} = 37.5V$, $V_{SS} = -12.5V$ All switches ON	25°C	680		800	μA
			–40°C to +85°C			850	
			–40°C to +125°C			900	

(1) When V_S is positive, V_D is negative, or when V_S is negative, V_D is positive.

(2) When V_S is at a voltage potential, V_D is floating, or when V_D is at a voltage potential, V_S is floating.

5.12 Switching Characteristics (+37.5V/–12.5V Dual Supply)

$V_{DD} = +37.5V \pm 10\%$, $V_{SS} = -12.5V \pm 10\%$, GND = 0V (unless otherwise noted)

$V_{DD} = +37.5V \pm 10\%$, $V_{SS} = -12.5V$, $T_A = 25^\circ C$ (unless otherwise noted)

PARAMETER		TEST CONDITIONS	T_A	MIN	TYP	MAX	UNIT
t_{ON}	Turn-on time from control input	$V_S = 10V$ $R_L = 300\Omega$, $C_L = 35pF$	25°C		2.1	3	μs
			–40°C to +85°C			3.5	μs
			–40°C to +125°C			4	μs
t_{OFF}	Turn-off time from control input	$V_S = 10V$ $R_L = 300\Omega$, $C_L = 35pF$	25°C		1.74	2	μs
			–40°C to +85°C			2.1	μs
			–40°C to +125°C			2.5	μs
t_{BBM}	Break-before-make time delay	$V_S = 10V$, $R_L = 300\Omega$, $C_L = 35pF$	25°C		350		ns
			–40°C to +85°C		150		ns
			–40°C to +125°C		150		ns
Q_{INJ}	Charge injection	$V_S = 12.5V$, $C_L = 100pF$	25°C		6.5		pC
O_{ISO}	Off-isolation	$R_L = 50\Omega$, $C_L = 5pF$ $V_S = 200mV_{RMS}$, $V_{BIAS} = 12.5V$, $f = 100kHz$	25°C		–96		dB
O_{ISO}	Off-isolation	$R_L = 50\Omega$, $C_L = 5pF$ $V_S = 200mV_{RMS}$, $V_{BIAS} = 12.5V$, $f = 1MHz$	25°C		–72		dB
X_{TALK}	Crosstalk	$R_L = 50\Omega$, $C_L = 5pF$ $V_S = 200mV_{RMS}$, $V_{BIAS} = 12.5V$, $f = 100kHz$	25°C		–110		dB
X_{TALK}	Crosstalk	$R_L = 50\Omega$, $C_L = 5pF$ $V_S = 200mV_{RMS}$, $V_{BIAS} = 12.5V$, $f = 1MHz$	25°C		–100		dB
BW	–3dB Bandwidth	$R_L = 50\Omega$, $C_L = 5pF$ $V_S = 200mV_{RMS}$, $V_{BIAS} = 12.5V$,	25°C		180		MHz
I_L	Insertion loss	$R_L = 50\Omega$, $C_L = 5pF$ $V_S = 200mV_{RMS}$, $V_{BIAS} = 12.5V$, $f = 1MHz$	25°C		–0.082		dB
ACPSRR	AC Power Supply Rejection Ratio	$V_{PP} = 0.62V$ on V_{DD} and V_{SS} $R_L = 50\Omega$, $C_L = 5pF$, $f = 1MHz$	25°C		–66		dB
THD+N	Total Harmonic Distortion + Noise	$V_{PP} = 15V$, $V_{BIAS} = 0V$ $R_L = 110\Omega$, $C_L = 5pF$, $f = 20Hz$ to 20kHz	25°C		0.0005		%
$C_{S(OFF)}$	Source off capacitance to ground	$V_S = 12.5V$, $f = 1MHz$	25°C		24		pF
$C_{D(OFF)}$	Drain off capacitance to ground	$V_S = 12.5V$, $f = 1MHz$	25°C		24		pF
$C_{S(ON)}$, $C_{D(ON)}$	On capacitance to ground	$V_S = 12.5V$, $f = 1MHz$	25°C		27		pF

5.13 Electrical Characteristics (12V Single Supply)

$V_{DD} = +12V \pm 10\%$, $V_{SS} = 0V$, $GND = 0V$ (unless otherwise noted)
Typical at $V_{DD} = +12V$, $V_{SS} = 0V$, $T_A = 25^\circ C$ (unless otherwise noted)

PARAMETER		TEST CONDITIONS	T_A	MIN	TYP	MAX	UNIT
ANALOG SWITCH							
R_{ON}	On-resistance	$V_S = 3V$ to $7V$ $I_D = -10mA$	$25^\circ C$	1.15	1.6		Ω
			$-40^\circ C$ to $+50^\circ C$			1.75	
			$-40^\circ C$ to $+85^\circ C$			2	
			$-40^\circ C$ to $+125^\circ C$			2.3	
ΔR_{ON}	On-resistance mismatch between channels	$V_S = 3V$ to $7V$ $I_D = -10mA$	$25^\circ C$	0.015			Ω
			$-40^\circ C$ to $+50^\circ C$			0.050	
			$-40^\circ C$ to $+85^\circ C$			0.055	
			$-40^\circ C$ to $+125^\circ C$			0.060	
$R_{ON\ FLAT}$	On-resistance flatness	$V_S = 3V$ to $7V$ $I_D = -10mA$	$25^\circ C$	0.084			Ω
			$-40^\circ C$ to $+50^\circ C$			0.13	
			$-40^\circ C$ to $+85^\circ C$			0.14	
			$-40^\circ C$ to $+125^\circ C$			0.16	
$R_{ON\ DRIFT}$	On-resistance drift	$V_S = 0V$, $I_S = -10mA$	$-40^\circ C$ to $+125^\circ C$	0.006			$\Omega/^\circ C$
$I_{S(OFF)}$	Source off leakage current ⁽¹⁾	$V_{DD} = 13.2V$, $V_{SS} = 0V$ Switch state is off $V_S = 1V / 10V$ $V_D = 10V / 1V$	$25^\circ C$	-0.35	0.003	0.35	nA
			$-40^\circ C$ to $+50^\circ C$	-0.4		0.4	
			$-40^\circ C$ to $+85^\circ C$	-1.5		1.5	
$I_{D(OFF)}$	Drain off leakage current ⁽¹⁾	$V_{DD} = 13.2V$, $V_{SS} = 0V$ Switch state is off $V_S = 1V / 10V$ $V_D = 10V / 1V$	$25^\circ C$	-0.35	0.003	0.35	nA
			$-40^\circ C$ to $+50^\circ C$	-0.4		0.4	
			$-40^\circ C$ to $+85^\circ C$	-1.5		1.5	
$I_{S(ON)}$ $I_{D(ON)}$	Channel on leakage current ⁽²⁾	$V_{DD} = 13.2V$, $V_{SS} = 0V$ Switch state is on $V_S = V_D = 1V$ or $10V$	$25^\circ C$	-0.7	0.003	0.7	nA
			$-40^\circ C$ to $+50^\circ C$	-0.85		0.85	
			$-40^\circ C$ to $+85^\circ C$	-1.2		1.2	
POWER SUPPLY							
I_{DDQ}	V_{DD} quiescent supply current	$V_{DD} = 13.2V$, $V_{SS} = 0V$ All switches OFF	$25^\circ C$	30	65		μA
			$-40^\circ C$ to $+85^\circ C$			100	
			$-40^\circ C$ to $+125^\circ C$			115	
I_{DD}	V_{DD} supply current	$V_{DD} = 13.2V$, $V_{SS} = 0V$ All switches ON	$25^\circ C$	840	1110		μA
			$-40^\circ C$ to $+85^\circ C$			1120	
			$-40^\circ C$ to $+125^\circ C$			1125	

- (1) When V_S is positive, V_D is negative, or when V_S is negative, V_D is positive.
(2) When V_S is at a voltage potential, V_D is floating, or when V_D is at a voltage potential, V_S is floating.

5.14 Switching Characteristics (12V Single Supply)

$V_{DD} = +12V \pm 10\%$, $V_{SS} = 0V$, $GND = 0V$ (unless otherwise noted)

Typical at $V_{DD} = +12V$, $V_{SS} = 0V$, $T_A = 25^\circ C$ (unless otherwise noted)

PARAMETER		TEST CONDITIONS	T_A	MIN	TYP	MAX	UNIT
t_{ON}	Turn-on time from control input	$V_S = 8V$ $R_L = 300\Omega$, $C_L = 35pF$	25°C		2	2.5	μs
			-40°C to +85°C			3	μs
			-40°C to +125°C			3.5	μs
t_{OFF}	Turn-off time from control input	$V_S = 8V$ $R_L = 300\Omega$, $C_L = 35pF$	25°C		1.7	2.2	μs
			-40°C to +85°C			2.5	μs
			-40°C to +125°C			3	μs
t_{BBM}	Break-before-make time delay	$V_S = 8V$, $R_L = 300\Omega$, $C_L = 35pF$	25°C		320		ns
			-40°C to +85°C	160			ns
			-40°C to +125°C	160			ns
Q_{INJ}	Charge injection	$V_S = 6V$, $C_L = 100pF$	25°C		4		pC
O_{ISO}	Off-isolation	$R_L = 50\Omega$, $C_L = 5pF$ $V_S = 200mV_{RMS}$, $V_{BIAS} = 6V$, $f = 100kHz$	25°C		-95		dB
O_{ISO}	Off-isolation	$R_L = 50\Omega$, $C_L = 5pF$ $V_S = 200mV_{RMS}$, $V_{BIAS} = 6V$, $f = 1MHz$	25°C		-66		dB
X_{TALK}	Crosstalk	$R_L = 50\Omega$, $C_L = 5pF$ $V_S = 200mV_{RMS}$, $V_{BIAS} = 6V$, $f = 100kHz$	25°C		-105		dB
X_{TALK}	Crosstalk	$R_L = 50\Omega$, $C_L = 5pF$ $V_S = 200mV_{RMS}$, $V_{BIAS} = 6V$, $f = 1MHz$	25°C		-105		dB
BW	-3dB Bandwidth	$R_L = 50\Omega$, $C_L = 5pF$ $V_S = 200mV_{RMS}$, $V_{BIAS} = 6V$	25°C		160		MHz
I_L	Insertion loss	$R_L = 50\Omega$, $C_L = 5pF$ $V_S = 200mV_{RMS}$, $V_{BIAS} = 6V$, $f = 1MHz$	25°C		-0.082		dB
ACPSRR	AC Power Supply Rejection Ratio	$V_{PP} = 0.62V$ on V_{DD} and V_{SS} $R_L = 50\Omega$, $C_L = 5pF$, $f = 1MHz$	25°C		-65		dB
THD+N	Total Harmonic Distortion + Noise	$V_{PP} = 6V$, $V_{BIAS} = 6V$ $R_L = 110\Omega$, $C_L = 5pF$, $f = 20Hz$ to $20kHz$	25°C		0.0095		%
$C_{S(OFF)}$	Source off capacitance to ground	$V_S = 6V$, $f = 1MHz$	25°C		39		pF
$C_{D(OFF)}$	Drain off capacitance to ground	$V_S = 6V$, $f = 1MHz$	25°C		39		pF
$C_{S(ON)}$, $C_{D(ON)}$	On capacitance to ground	$V_S = 6V$, $f = 1MHz$	25°C		34		pF

5.15 SPI Timing Characteristics (2.7V to 5.5V)

$V_L = 2.7V - 5.5V$, $GND = 0V$ (unless otherwise noted)

Typical at $V_L = 3.3V$, $T_A = 25^\circ C$ (unless otherwise noted)

PARAMETER	TEST CONDITIONS	T_A	MIN	TYP	MAX	UNIT
f_{CLK_SPI}	SCLK Frequency	-40°C to +125°C			50	MHz
t_R , t_F_SPI	SPI Clock Rise and Fall Times	-40°C to +125°C			50	ns
t_{CLK_SPI}	SCLK Period	-40°C to +125°C	20			ns
$t_{CLK_H_SPI}$	SCLK High Time	-40°C to +125°C	8			ns
$t_{CLK_L_SPI}$	SCLK Low Time	-40°C to +125°C	8			ns

5.15 SPI Timing Characteristics (2.7V to 5.5V) (continued)

 $V_L = 2.7V - 5.5V$, GND = 0V (unless otherwise noted)

 Typical at $V_L = 3.3V$, $T_A = 25^\circ C$ (unless otherwise noted)

PARAMETER		TEST CONDITIONS	T_A	MIN	TYP	MAX	UNIT
t_{CSS}	Set Up Time \overline{CS} to SCLK		$-40^\circ C$ to $+125^\circ C$	10			ns
t_{SU_SPI}	Set Up Time SDI to SCLK		$-40^\circ C$ to $+125^\circ C$	6			ns
t_{H_SPI}	Hold Time SDI to SCLK		$-40^\circ C$ to $+125^\circ C$	8			ns
t_{CSH}	Hold Time SCLK to \overline{CS}		$-40^\circ C$ to $+125^\circ C$	10			ns
t_{CSLSDO}	\overline{CS} falling edge to SDO	20pF	$-40^\circ C$ to $+125^\circ C$			25	ns
t_{SDO}	SCLK falling edge to SDO	20pF	$-40^\circ C$ to $+125^\circ C$			25	ns
t_{CSHSDO}	\overline{CS} rising edge to SDO returns to high	20pF	$-40^\circ C$ to $+125^\circ C$			25	ns
t_{CSD}	\overline{CS} high time between SPI commands		$-40^\circ C$ to $+125^\circ C$	20			ns
$t_{CSLSCLK}$	CS falling edge to SCLK becomes stable		$-40^\circ C$ to $+125^\circ C$	8			ns
$t_{CSHSCLK}$	CS rising edge to SCLK becomes stable		$-40^\circ C$ to $+125^\circ C$	8			ns

5.16 SPI Timing Characteristics (1.8V to 2.7V)

 $V_L = 1.8V - 2.7V$, GND = 0V (unless otherwise noted)

 Typical at $V_L = 1.8V$, $T_A = 25^\circ C$ (unless otherwise noted)

PARAMETER		TEST CONDITIONS	T_A	MIN	TYP	MAX	UNIT
f_{CLK_SPI}	SCLK Frequency		$-40^\circ C$ to $+125^\circ C$			25	MHz
t_R, t_F_SPI	SPI Clock Rise and Fall Times		$-40^\circ C$ to $+125^\circ C$			25	ns
t_{CLK_SPI}	SCLK Period		$-40^\circ C$ to $+125^\circ C$	40			ns
$t_{CLK_H_SPI}$	SCLK High Time		$-40^\circ C$ to $+125^\circ C$	16			ns
$t_{CLK_L_SPI}$	SCLK Low Time		$-40^\circ C$ to $+125^\circ C$	16			ns
t_{CSS}	Set Up Time \overline{CS} to SCLK		$-40^\circ C$ to $+125^\circ C$	20			ns
t_{SU_SPI}	Set Up Time SDI to SCLK		$-40^\circ C$ to $+125^\circ C$	12			ns
t_{H_SPI}	Hold Time SDI to SCLK		$-40^\circ C$ to $+125^\circ C$	18			ns
t_{CSH}	Hold Time SCLK to \overline{CS}		$-40^\circ C$ to $+125^\circ C$	20			ns
t_{CSLSDO}	\overline{CS} falling edge to SDO	20pF	$-40^\circ C$ to $+125^\circ C$			50	ns
t_{SDO}	SCLK falling edge to SDO	20pF	$-40^\circ C$ to $+125^\circ C$			50	ns
t_{CSHSDO}	\overline{CS} rising edge to SDO returns to high	20pF	$-40^\circ C$ to $+125^\circ C$			50	ns
t_{CSD}	\overline{CS} high time between SPI commands		$-40^\circ C$ to $+125^\circ C$	40			ns
$t_{CSLSCLK}$	CS falling edge to SCLK becomes stable		$-40^\circ C$ to $+125^\circ C$	16			ns
$t_{CSHSCLK}$	CS rising edge to SCLK becomes stable		$-40^\circ C$ to $+125^\circ C$	16			ns

5.17 Timing Diagrams

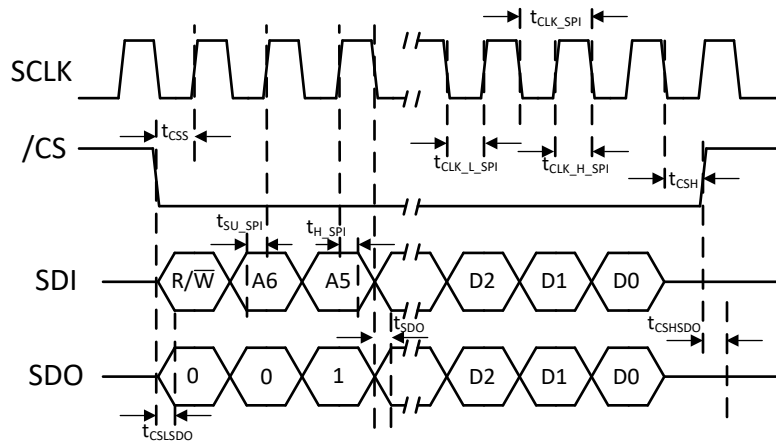

Figure 5-1. SPI Timing Diagram

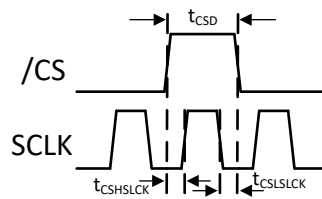

Figure 5-2. SCLK and /CS Timing Relationship

5.18 Typical Characteristics

at $T_A = 25^\circ\text{C}$ (unless otherwise noted)

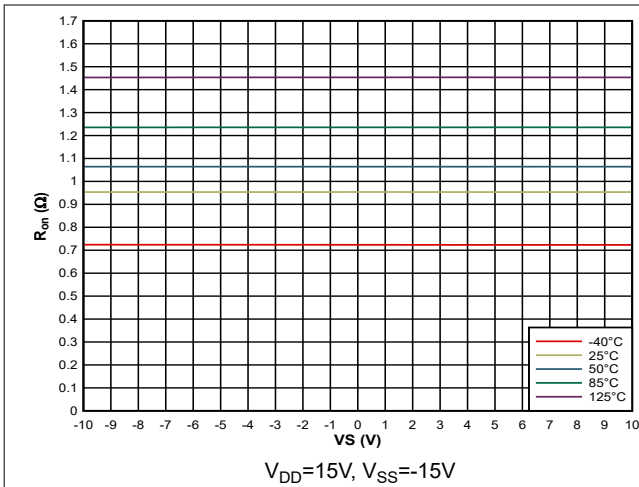

Figure 5-3. On-Resistance vs Source or Drain Operational Voltage

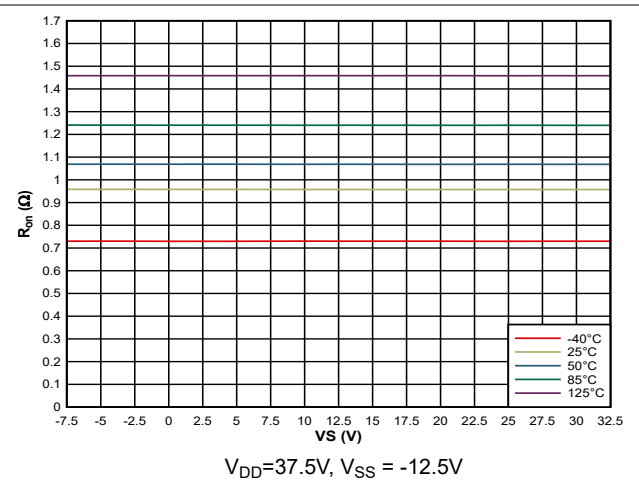

Figure 5-4. On-Resistance vs Source or Drain Operational Voltage

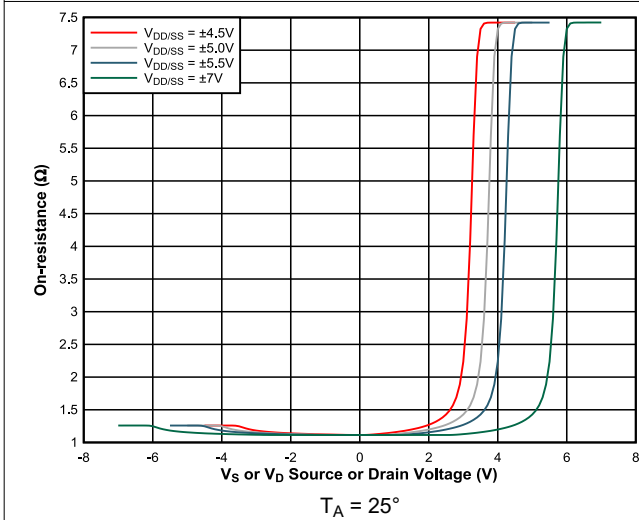

Figure 5-5. On-Resistance vs Source or Drain Voltage for dual supply

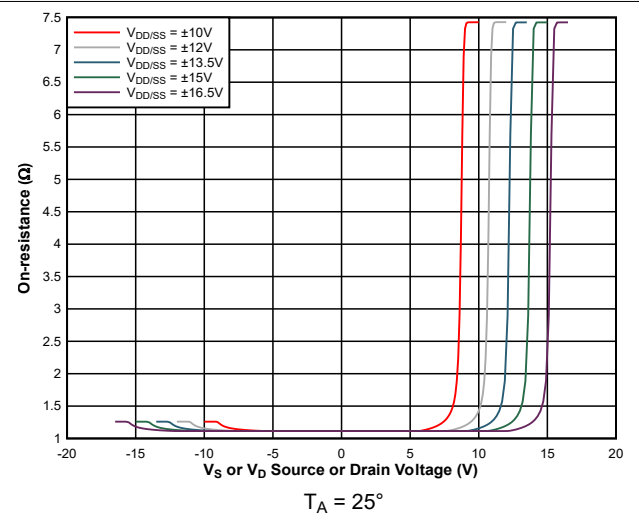

Figure 5-6. On-Resistance vs Source or Drain Voltage for dual supply

5.18 Typical Characteristics (continued)

at $T_A = 25^\circ\text{C}$ (unless otherwise noted)

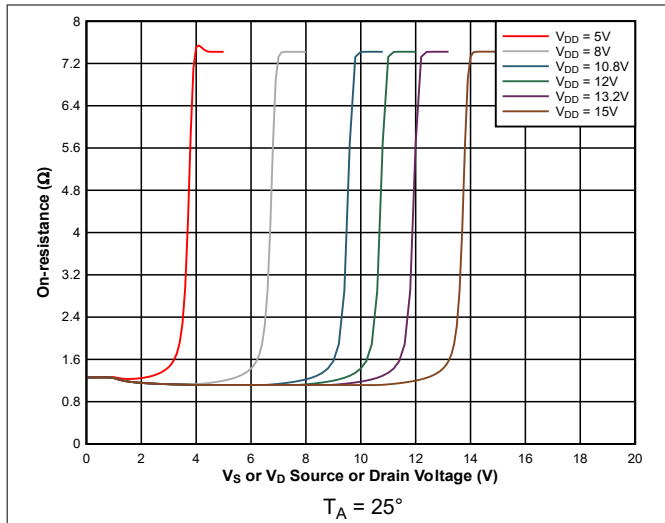

Figure 5-7. On-Resistance vs Source or Drain Voltage for single supply

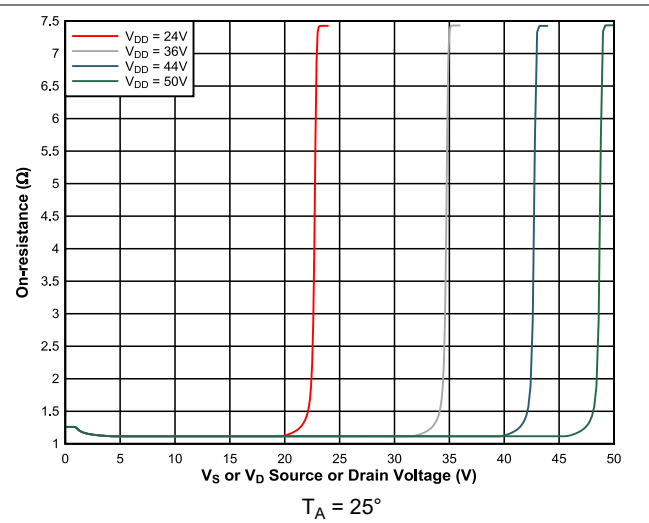

Figure 5-8. On-Resistance vs Source or Drain Voltage

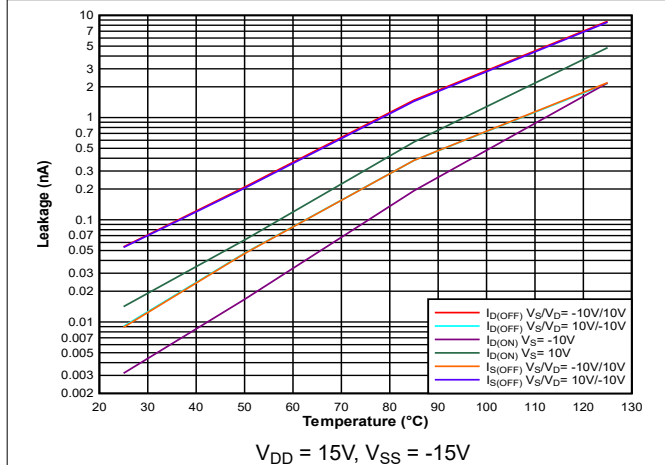

Figure 5-9. Leakage Current vs Temperature

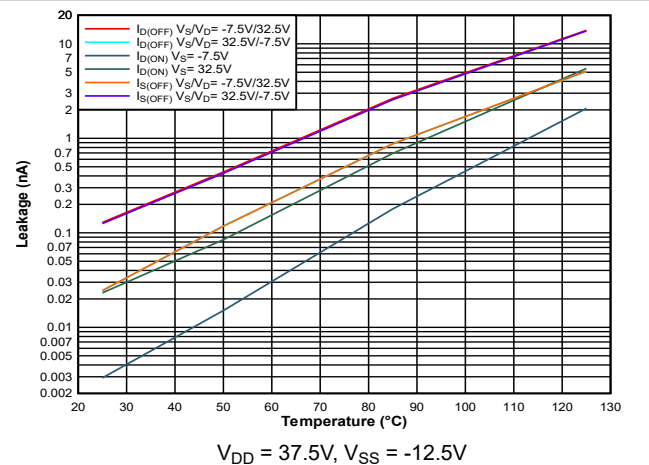

Figure 5-10. Leakage Current vs Temperature

5.18 Typical Characteristics (continued)

at $T_A = 25^\circ\text{C}$ (unless otherwise noted)

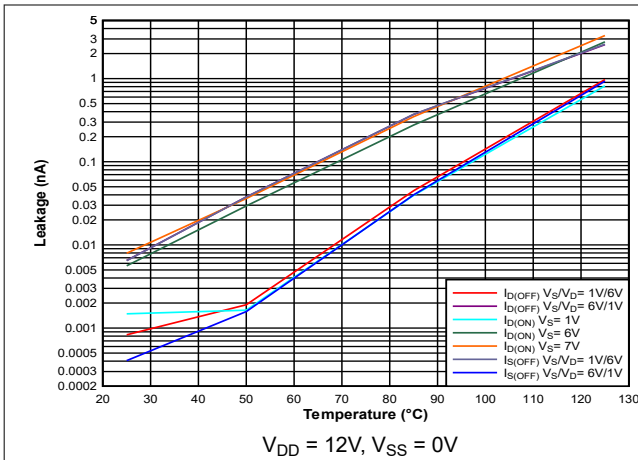

Figure 5-11. Leakage Current vs Temperature

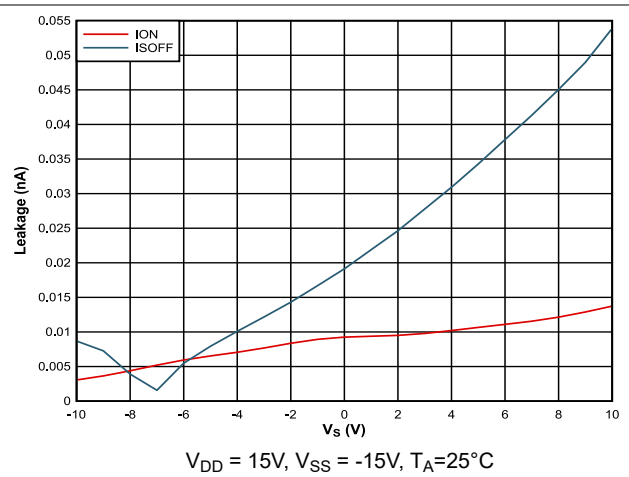

Figure 5-12. Leakage Current vs V_S

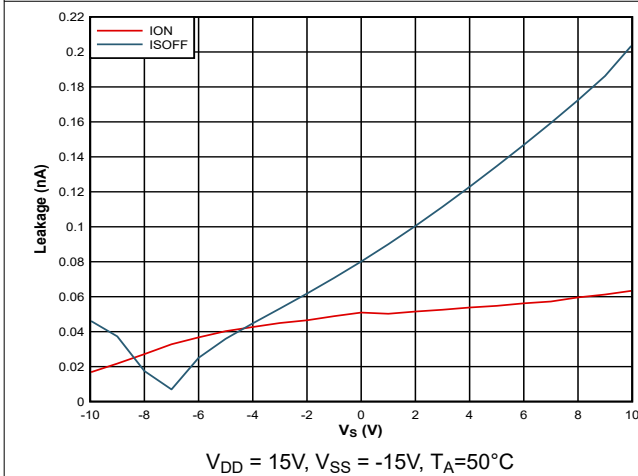

Figure 5-13. Leakage Current vs V_S

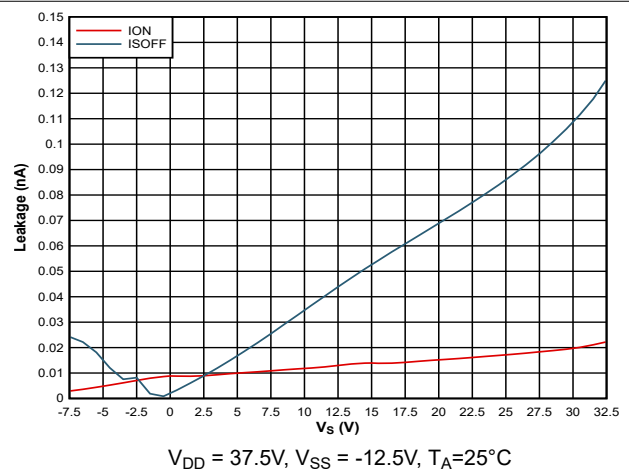

Figure 5-14. Leakage Current vs V_S

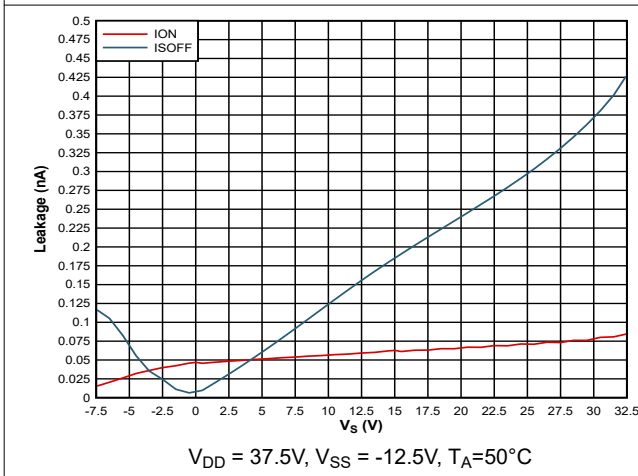

Figure 5-15. Leakage Current vs V_S

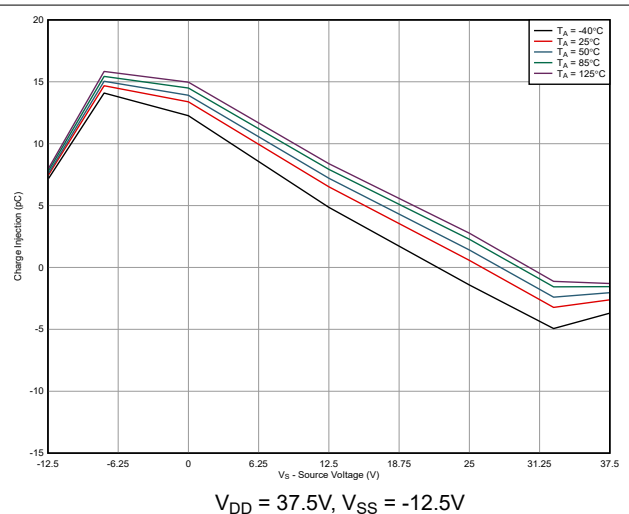

Figure 5-16. Charge Injection vs Source Voltage

5.18 Typical Characteristics (continued)

at $T_A = 25^\circ\text{C}$ (unless otherwise noted)

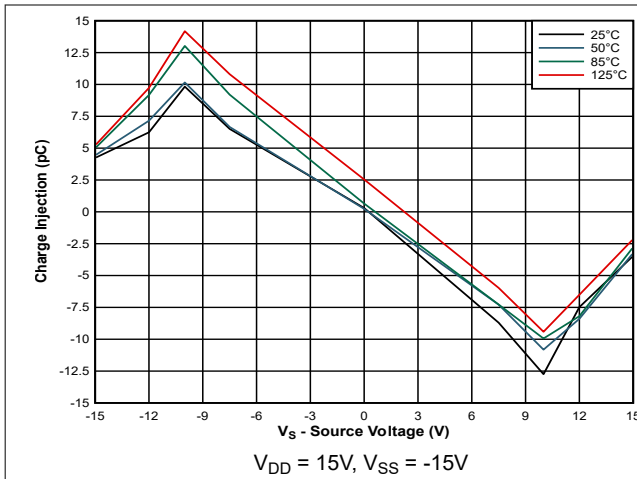

Figure 5-17. Charge Injection vs Source Voltage

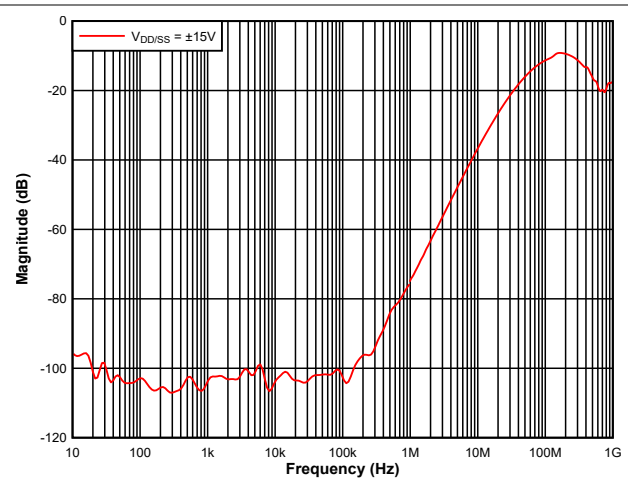

Figure 5-18. Off-Isolation vs Frequency

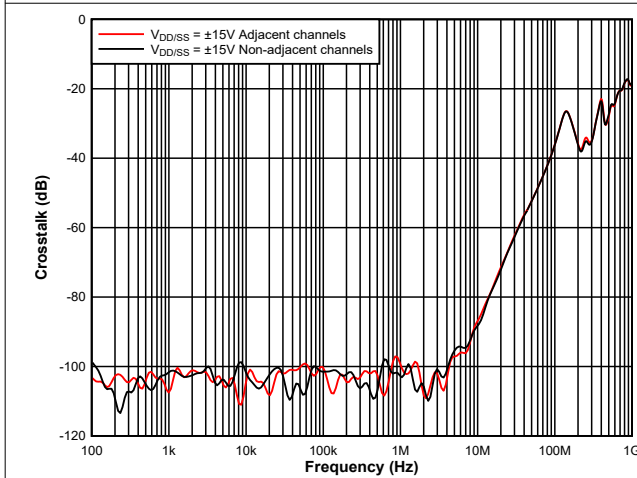

Figure 5-19. Crosstalk vs Frequency

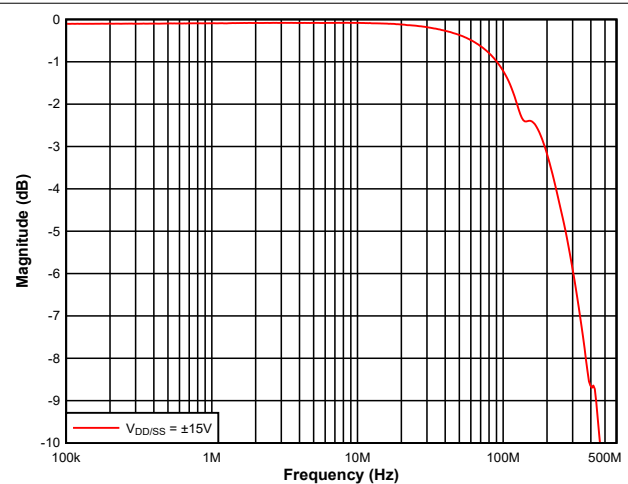

Figure 5-20. Bandwidth vs Frequency

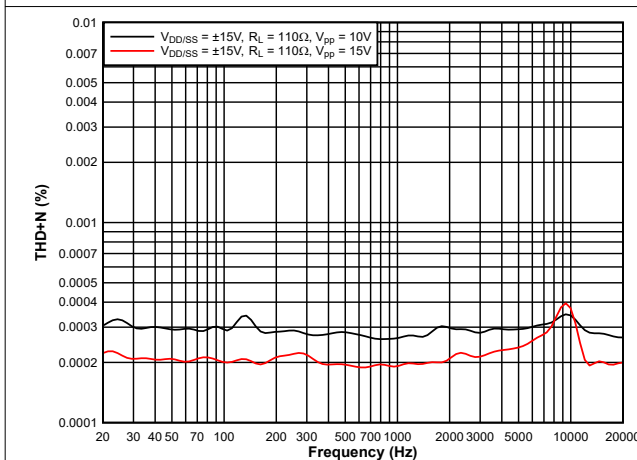

Figure 5-21. THD+N vs Frequency

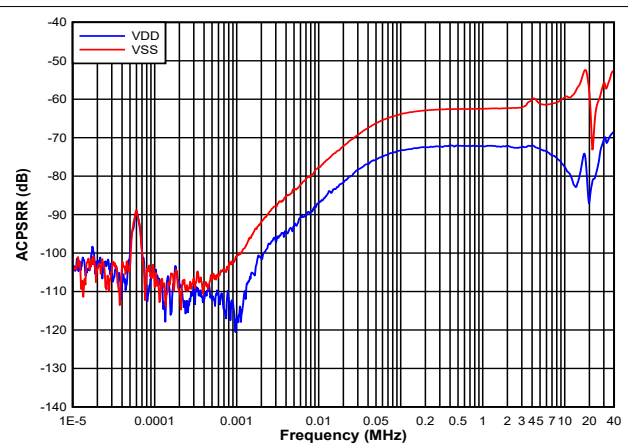
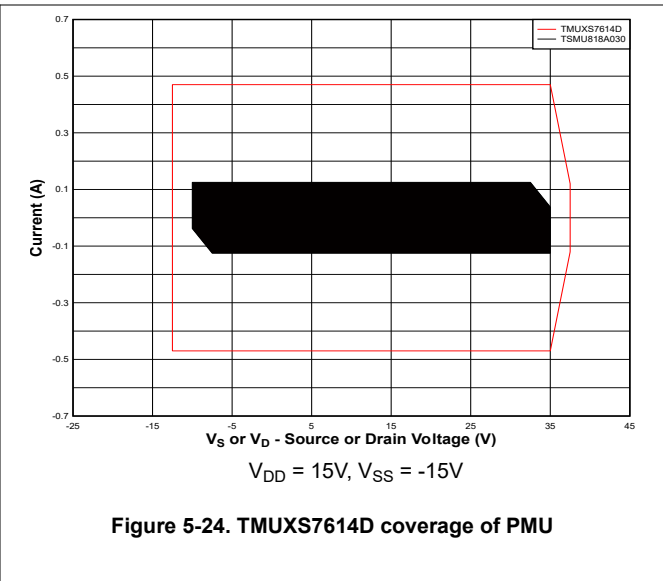
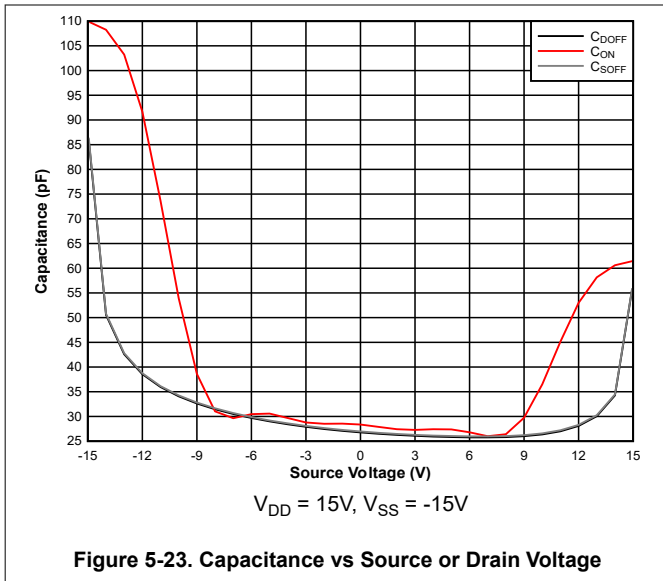

Figure 5-22. ACPSSR vs Frequency

5.18 Typical Characteristics (continued)

at $T_A = 25^\circ\text{C}$ (unless otherwise noted)



6 Parameter Measurement Information

6.1 On-Resistance

The on-resistance of a device is the ohmic resistance between the source (Sx) and drain (Dx) pins of the device. The on-resistance varies with input voltage and supply voltage. The symbol R_{ON} is used to denote on-resistance. Figure 6-1 shows the measurement setup used to measure R_{ON} . Voltage (V) and current (I_{SD}) are measured using this setup, and R_{ON} is computed with $R_{ON} = V / I_{SD}$:

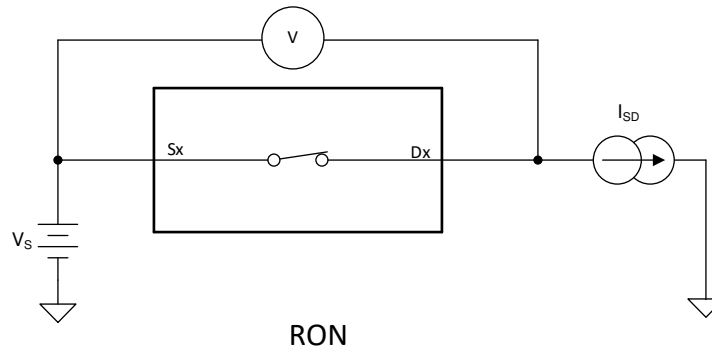

Figure 6-1. On-Resistance Measurement Setup

6.2 Off-Leakage Current

There are two types of leakage currents associated with a switch during the off state:

1. Source off-leakage current.
2. Drain off-leakage current.

Source leakage current is defined as the leakage current flowing into or out of the source pin when the switch is off. This current is denoted by the symbol $I_{S(OFF)}$.

Drain leakage current is defined as the leakage current flowing into or out of the drain pin when the switch is off. This current is denoted by the symbol $I_{D(OFF)}$.

Figure 6-2 shows the setup used to measure both off-leakage currents.

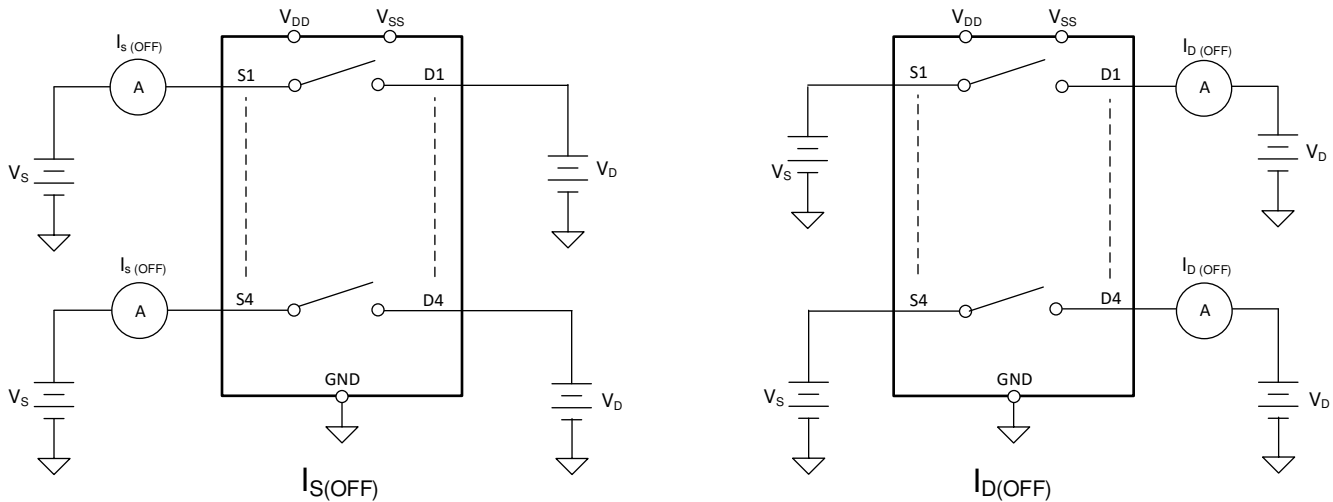

Figure 6-2. Off-Leakage Measurement Setup

6.3 On-Leakage Current

Source on-leakage current is defined as the leakage current flowing into or out of the source pin when the switch is on. This current is denoted by the symbol $I_{S(ON)}$.

Drain on-leakage current is defined as the leakage current flowing into or out of the drain pin when the switch is on. This current is denoted by the symbol $I_{D(ON)}$.

Either the source pin or drain pin is left floating during the measurement. Figure 6-3 shows the circuit used for measuring the on-leakage current, denoted by $I_{S(ON)}$ or $I_{D(ON)}$.

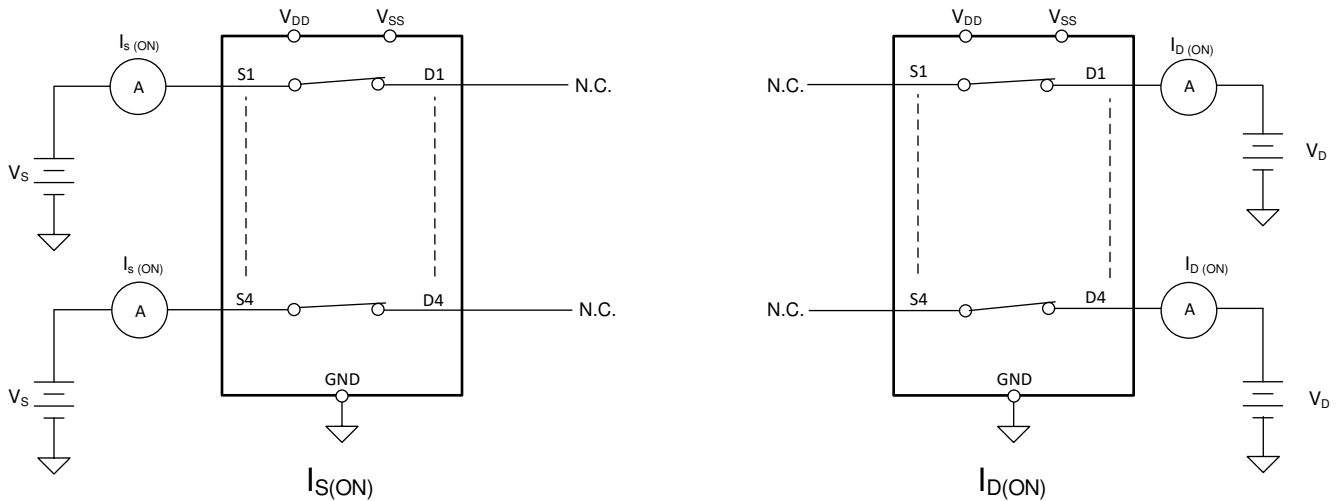

Figure 6-3. On-Leakage Measurement Setup

6.4 t_{ON} and t_{OFF} Time

Turn-on time is defined as the time taken by the output of the device to rise to 90% after the enable has risen past the logic threshold. The 90% measurement is utilized to provide the timing of the device. System level timing can then account for the time constant added from the load resistance and load capacitance. Figure 6-4 shows the setup used to measure turn-on time, denoted by the symbol t_{ON} .

Turn-off time is defined as the time taken by the output of the device to fall to 10% after the enable has fallen past the logic threshold. The 10% measurement is utilized to provide the timing of the device. System level timing can then account for the time constant added from the load resistance and load capacitance. Figure 6-4 shows the setup used to measure turn-off time, denoted by the symbol t_{OFF} .

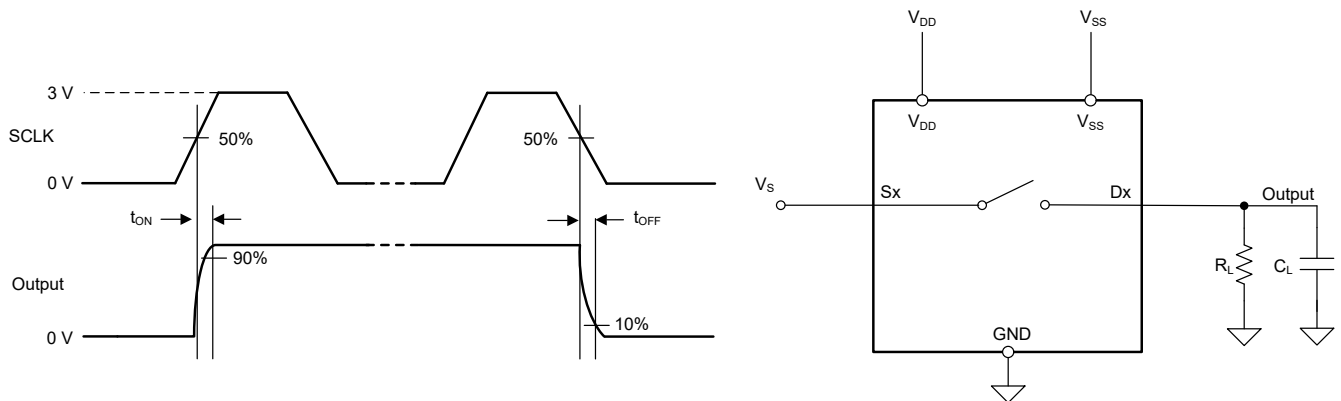

Figure 6-4. Turn-On and Turn-Off Time Measurement Setup

6.5 Break-Before-Make

The TMUXS7614D has break-before-make delay which allows the device to be used in cross-point switching application. The output first breaks from the on-state switch before making the connection with the next on-state switch. The time delay between the *break* and the *make* is known as break-before-make delay. Figure 6-5 shows the setup used to measure break-before-make delay, denoted by the symbol $t_{OPEN(BBM)}$.

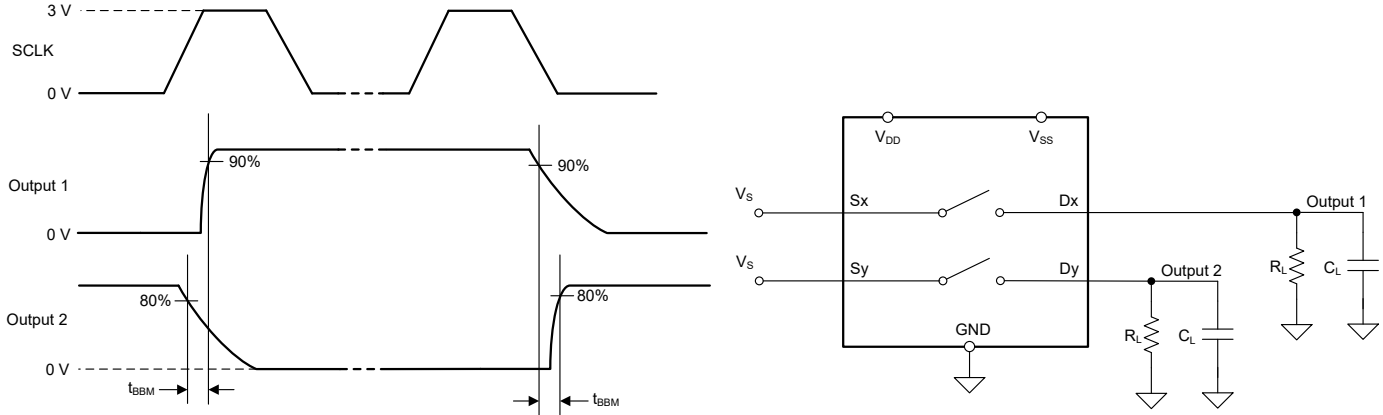

Figure 6-5. Break-Before-Make Delay Measurement Setup

6.6 Charge Injection

The TMUXS7614D devices have a transmission-gate topology. Any mismatch in capacitance between the NMOS and PMOS transistors results in a charge injected into the drain or source during the falling or rising edge of the gate signal. The amount of charge injected into the source or drain of the device is known as charge injection, and is denoted by the symbol Q_C . Figure 6-6 shows the setup used to measure charge injection from source (Sx) to drain (Dx).

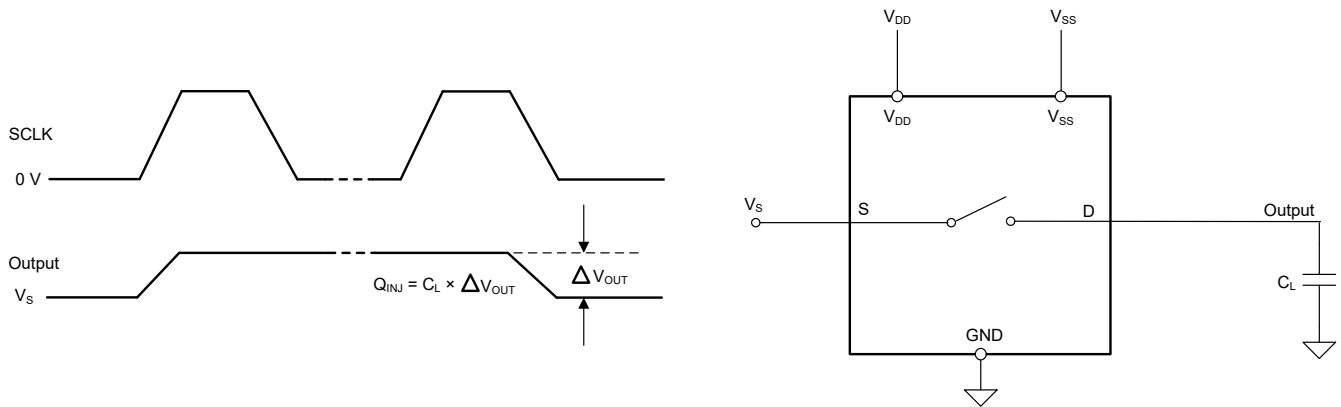

Figure 6-6. Charge-Injection Measurement Setup

6.7 Off Isolation

Off isolation is defined as the ratio of the signal at the drain pin (Dx) of the device when a signal is applied to the source pin (Sx) of an off-channel. The characteristic impedance, Z_0 , for the measurement is 50Ω. Figure 6-7 shows the setup used to measure off isolation. Use off isolation equation to compute off isolation.

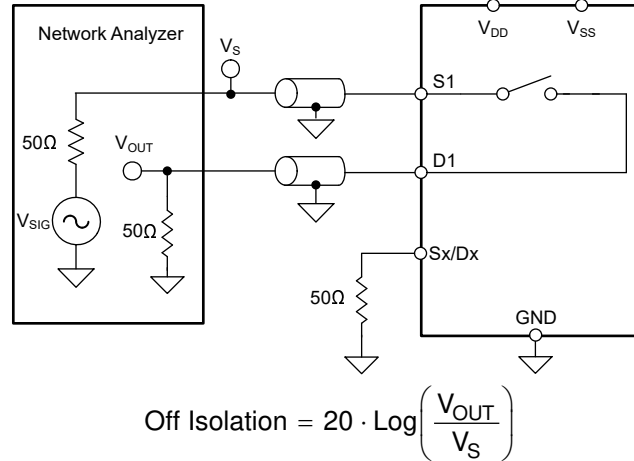

Figure 6-7. Off Isolation Measurement Setup

6.8 Channel-to-Channel Crosstalk

Crosstalk is defined as the ratio of the signal at the drain pin (Dx) of a different channel, when a signal is applied at the source pin (Sx) of an on-channel. The characteristic impedance, Z_0 , for the measurement is 50Ω. Figure 6-8 shows the setup used to measure, and the equation used to compute crosstalk.

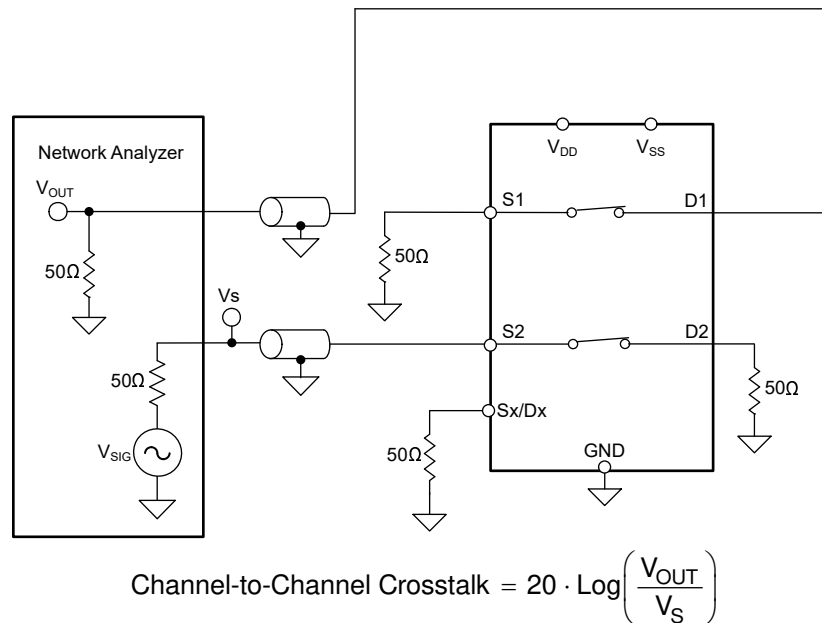

Figure 6-8. Channel-to-Channel Crosstalk Measurement Setup

6.9 Bandwidth

Bandwidth is defined as the range of frequencies that are attenuated by less than 3dB when the input is applied to the source pin (Sx) of an on-channel, and the output is measured at the drain pin (Dx) of the device. The characteristic impedance, Z_0 , for the measurement is 50Ω. Figure 6-9 shows the setup used to measure bandwidth.

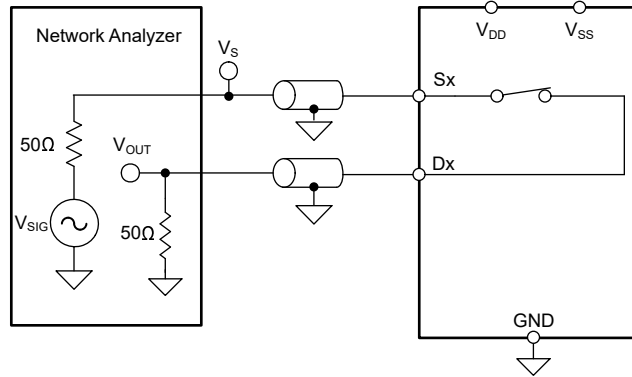

Figure 6-9. Bandwidth Measurement Setup

$$\text{Bandwidth} = 20 \times \text{Log} \left(\frac{V_{\text{out}}}{V_s} \right) \tag{1}$$

6.10 THD + Noise

The total harmonic distortion (THD) of a signal is a measurement of the harmonic distortion, and is defined as the ratio of the sum of the powers of all harmonic components to the power of the fundamental frequency at the mux output. The on-resistance of the device varies with the amplitude of the input signal and results in distortion when the drain pin is connected to a low-impedance load. Total harmonic distortion plus noise is denoted as THD + N.

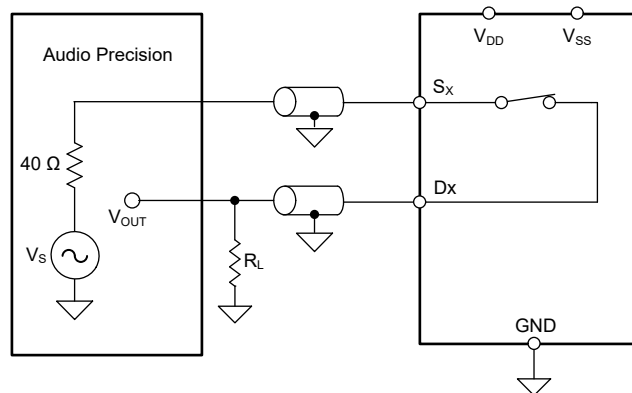

Figure 6-10. THD + N Measurement Setup

7 Detailed Description

7.1 Overview

The TMUXS7614D is a 1:1 (SPST), 8-channel switch. This device has eight independently selectable single-pole, single-throw switches that are turned-on or turned-off based on the SPI registers. This device works well with dual supplies, a single supply, or asymmetric supplies such as $V_{DD} = 37.5V$, $V_{SS} = -12V$.

7.2 Functional Block Diagram

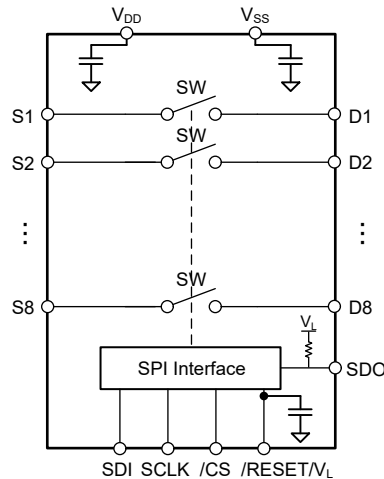

7.3 Feature Description

7.3.1 Bidirectional Operation

The TMUXS7614D conducts equally well from source (Sx) to drain (Dx) or from drain (Dx) to source (Sx). Each channel has similar characteristics in both directions and supports both analog and digital signals.

7.3.2 Rail-to-Rail Operation

The valid signal path input and output voltage for TMUXS7614D ranges from V_{SS} to V_{DD} .

7.3.3 1.8V Logic Compatible Inputs

The TMUXS7614D has 1.8V logic compatible control for all logic control inputs. 1.8V logic level inputs allows the TMUXS7614D to interface with processors that have lower logic I/O rails and eliminates the need for an external translator, which saves both space and BOM cost. Additionally, VL supports 1.8V – 5.5V, and SDO is based on VL. So no additional translator is needed to support SPI readback. For more information on 1.8V logic implementations, refer to [Simplifying Design with 1.8V logic Muxes and Switches](#).

7.3.4 Flat On-Resistance

The TMUXS7614D is designed with a special switch architecture to produce ultra-flat on-resistance (RON) across most of the switch input operating region. The flat RON response allows the device to be used in precision applications since the RON is controlled regardless of the signals sampled. The architecture is implemented without a charge pump so no unwanted noise is produced from the device to affect sampling accuracy.

This architecture also ensures that RON stays the same regardless of the supply voltage. The flattest on-resistance region extends from VSS to roughly 5V below VDD. The on-resistance will exponentially increase when the signal is within 5V of VDD, which may impact the desired signal transmission.

7.3.5 Power-Up Sequence Free

The TMUXS7614D supports any power up sequencing. With the three supply rails (V_{DD} , V_{SS} , and VL), any rail can be powered on first. Similarly when powering down, the supply rails can be powered down in any order.

7.4 SPI Operation

TMUXS7614D is SPI controlled with eight SPST switches and has SPI error detection features. SPI data input on SDI is sampled on the positive edge of SCLK, but SPI output data on SDO gets shifted out on the negative edge of SCLK. TMUXS7614D is compatible with SPI modes 0 and 3. While in the default mode, address mode, TMUXS7614D registers are accessed with 16-bit SPI commands sent while \overline{CS} is pulled low. [Burst Mode](#) and [Daisy Chain Mode](#) are other modes that TMUXS7614D can operate within. The following is a list of error detection features offered:

1. [Address R/W Error Flag](#)
2. [SCLK Count Error Flag](#)
3. [CRC \(Cyclic Redundancy Check\) Enable and Error Flag](#)
4. [Clearing Error Flags](#)

TMUXS7614D SPI pins include SDI, SDO, SCLK and \overline{CS} .

7.4.1 Address Mode

The default state of TMUXS7614D is address mode. While in address mode the SPI frame expects the following sequence:

1. \overline{CS} is pulled low
2. Default of 16 SCLK cycles (or 24 SCLK cycles if CRC is enabled), 16-bit command (1 R/W bit, 7 address bits, followed by an 8-bit data)
3. \overline{CS} is pulled high

When the first bit of command is a 0 it indicates a write is being performed or when the first bit is a 1 it indicates a read is being performed. The next 7 bits following are for the target register address. The target register is determined during the 8th SCLK cycle. The last 8 bits are written to the targeted register on the 16th SCLK cycle, or they are ignored when performing a read. While performing a read the last 8 bits on SDI are ignored since SDO will output the addressed register state during these last 8 SCLK cycles. During the first eight bits of any command SPI sends out 8 alignment bits "0x25" on SDO.

7.4.2 Burst Mode

TMUXS7614D enters burst mode through a write to the burst mode enable bit in the BURST_EN register found in the [Register Map](#). Burst mode grants the ability to send numerous SPI commands consecutively without deasserting the \overline{CS} pin. While in burst mode the operation is in 16-bit frames by default or with CRC enabled 24-bit frames. The SDO pin aligns with the same response expected while in address mode- for reads SDO returns read-back values, and for writes SDO outputs 0x2500. The SCLK error behaves in a different manner to address mode. If the SCLK count is not a multiple of 16 or 24 then the SCLK error flag asserts. CRC and read/write invalid errors operate while in burst mode similarly to operation in address mode.

7.4.3 Daisy Chain Mode

Multiple TMUXS7614D can be chained together to operate similarly to a shift register. All SPI pins are shared across all devices in the chain, but the SDO pin is connected to the SDI of the next device in the chain. Daisy chain mode is entered by sending the command "0x2500". When multiple devices are configured in hardware to be in daisy chain mode the first command sent is expected to be the daisy chain mode entry command. As the first device is entering daisy chain mode it is simultaneously sending out "0x2500" to enter the next device into daisy chain mode. Once the series of devices is in daisy chain mode the CS pin will need to be pulled low to send switch state commands.

The SDO pin acts as an eight cycle delayed SDI of the same device. After all devices in the chain have received a switch state command and the CS pin is pulled high- each device will enter the switch states that were assigned to it. While in daisy chain mode all commands will only target the switch state registers so configuration registers will be unavailable. To leave daisy chain mode a power cycle of V_L will be necessary. The layout for daisy-chain is extremely simple due to the flow through routing capable pins as shown in the [Section 8.6.2](#)

7.4.4 Error Detection

TMUXS7614D has robust SPI communication protocol error detection features that are covered in the following sections.

7.4.4.1 Address R/W Error Flag

When an invalid register address is the target for a read or write- an error is detected on the rising edge of the 9th SCLK cycle and asserts an error flag. Invalid registers include: writing to a read only register or a nonexistent register is targeted for either a read or a write. This is a default setting and can be configured through the R/W error enable bit in the ERR_CONFIG register.

7.4.4.2 SCLK Count Error Flag

The SCLK count error flag asserts when an incorrect number of SCLK cycles are sent to the device. In address mode the expected SCLK cycles is 16 and with CRC enabled the expected count is 24. If less than 16 (address mode) or 24 (with CRC enabled) are received then the device prevents writes to the register map. If there are more cycles than expected the write still occurs; however, an SCLK count error flag asserts. SCLK count error is enabled by default and can be configured through the SCLK count error enable bit in the ERR_CONFIG register.

7.4.4.3 CRC (Cyclic Redundancy Check) Enable and Error Flag

CRC is disabled by default and can be enabled through the CRC_ERR_EN bit in the ERR_CONFIG register. When CRC is enabled the expected SCLK cycles change from 16 to 24. The additional 8 cycles are the CRC byte that is calculated by the device from the initial 16-bits of data (R/W bit, register address [6:0], and the register data [7:0]). Writes occur on the rising edge of the 24th SCLK rising edge. The CRC polynomial used is $x^8+x^2+x^1+1$ using a value of 0 as the seed.

The CRC byte, during a SPI write, is provided by the central processing unit or microcontroller. This byte is checked before the 24th SCLK rising edge by the SPI block to confirm the CRC byte aligns with the first 16 bits received. If the CRC byte is incorrect then the register write is blocked and the CRC error flag asserts. TMUXS7614D provides the CRC byte through SDO during a SPI read.

7.4.4.4 Clearing Error Flags

To clear out the error flag register the 16-bit command 0x6CA9 must be sent to TMUXS7614D. With CRC enabled, the correct CRC byte must be provided for the error clear command to execute. On either the 16th or 24th SCLK rising edge (24th for CRC enabled) the error flag register is cleared. 0x6CA9 does not trigger the R/W address error flag.

7.4.5 Software Reset

While in address mode, a software reset can be performed by writing the two following commands consecutively to the register 0x0B:

1. 0xA3
2. 0x05

The register values reset to default after performing a software reset.

7.5 Device Functional Modes

The TMUXS7614D has eight independently selectable single-pole, single-throw switches that are turned-on or turned-off through the SPI interface. This device can operate without any external components. This is because 0.1µF decoupling capacitors are integrated into the device for VDD, VSS, and VL.

The SPI interface features error detection, support daisy chain with multiple devices, and SPI modes 0 and 3. Additionally, the SCLK can operate at speeds up to 50MHz for SPI logic levels 2.7V to 5.5V.

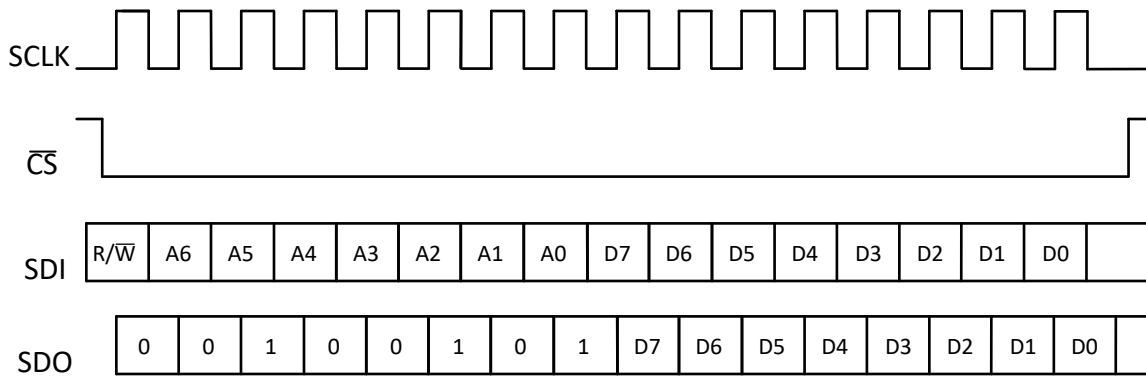

Figure 7-1. SPI Address Mode Diagram (16-bits)

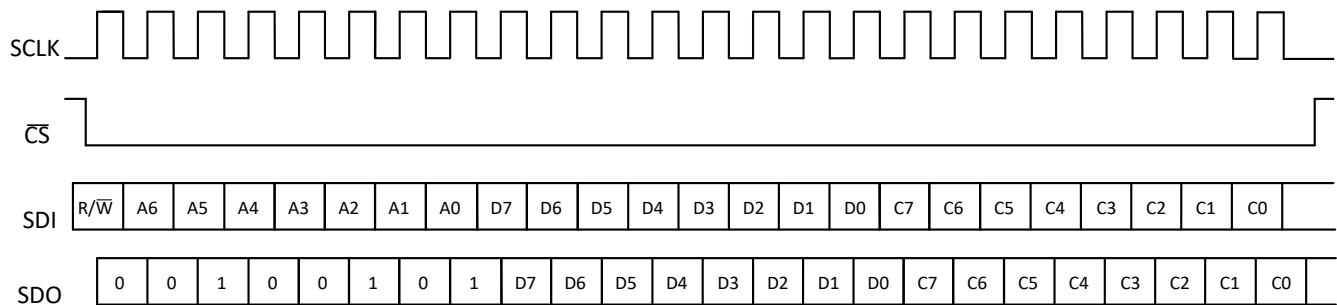

Figure 7-2. SPI Address Mode Diagram with CRC (24-bits)

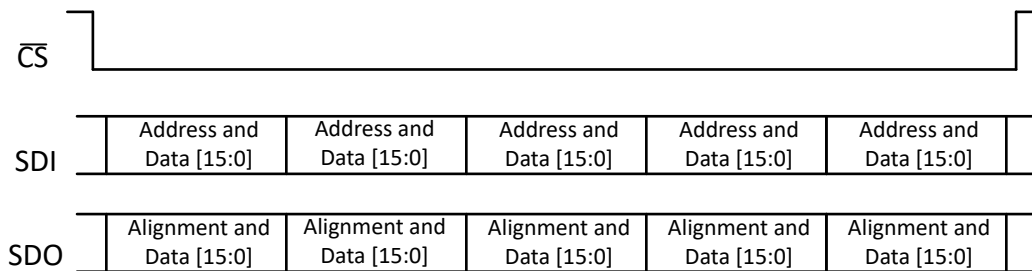

Figure 7-3. SPI Burst Mode Example

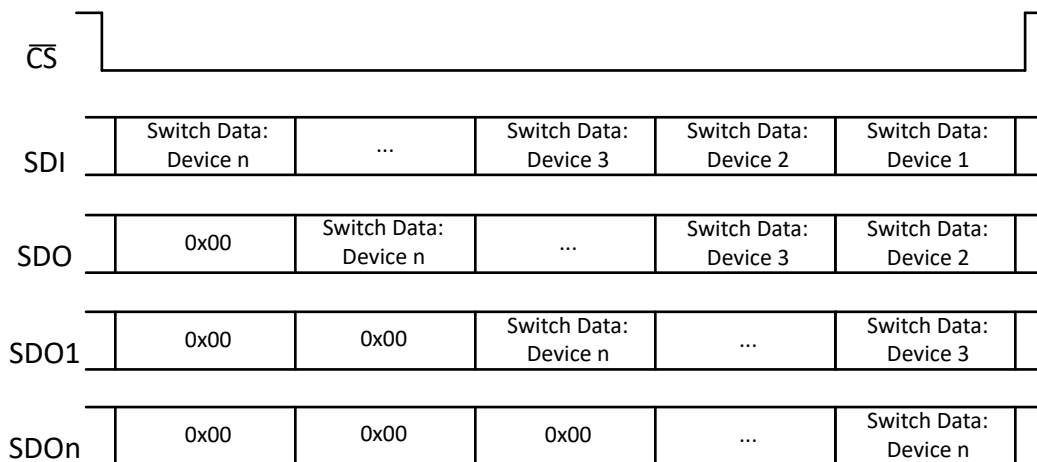

Figure 7-4. SPI Daisy Chain Mode Example

7.6 Register Map

Table 7-1.

Register	Name	Bit 7	Bit 6	Bit 5	Bit 4	Bit 3	Bit 2	Bit 1	Bit 0	Default	Permission
0x01	SW_DATA	SW8_EN	SW7_EN	SW6_EN	SW5_EN	SW4_EN	SW3_EN	SW2_EN	SW1_EN	0x00	R/W
0x02	ERR_CONFIG	Reserved					RW_ERR_EN	SCLK_ERR_EN	CRC_ERR_EN	0x06	R/W
0x03	ERR_FLAGS	Reserved					RW_ERR_FLAG	SCLK_ERR_FLAG	CRC_ERR_FLAG	0x00	R
0x05	BURST_EN	Reserved							BURST_MODE_EN	0x00	R/W
0x0B	SOFT_RESETB	SOFT_RESETB								0x00	R/W

8 Application and Implementation

Note

Information in the following applications sections is not part of the TI component specification, and TI does not warrant its accuracy or completeness. TI's customers are responsible for determining suitability of components for their purposes, as well as validating and testing their design implementation to confirm system functionality.

8.1 Application Information

The TMUXS7614D is part of the precision switches and multiplexers family of devices. These devices operate with dual supplies ($\pm 4.5V$ to $\pm 25V$), a single supply (4.5V to 42V), or asymmetric supplies (such as $V_{DD} = 12V$, $V_{SS} = -5V$), and offer true rail-to-rail input and output. The TMUXS7614D offers low R_{ON} , low on and off leakage currents and ultra-low charge injection performance. These features make the TMUXS7614D a family of precision, robust, high-performance analog multiplexer for high-voltage, industrial applications.

8.2 Typical Application

The implementation of a parametric measurement unit (PMU) in the semiconductor automatic test equipment (ATE) application is one example of precision performance to take advantage of.

In automated test equipment (ATE) systems, the parametric measurement unit (PMU) is tasked to measure device (DUT) parametric information in terms of voltage and current. When measuring voltage, current is applied at the DUT pin, and the current range can be adjusted by changing the value of the internal sense resistor. Sometimes there is a need, depending on the DUT, to use even higher testing current than natively supported by the system. A 8 channel SPST switch can be used with an external higher current amplifier and resistor to achieve the flexibility. The PMU operating voltage is typically in mid voltage (up to 36V). An appropriate switch like the TMUXS7614D with a low leakage current (0.013nA typical) works well in these applications because of its minimal impact on measurement accuracy, and the low R_{ON} and flat $R_{ON_FLATNESS}$ offered allows the current range to be controlled more precisely. Figure 8-1 shows simplified diagram of such implementations in memory and semiconductor test equipment.

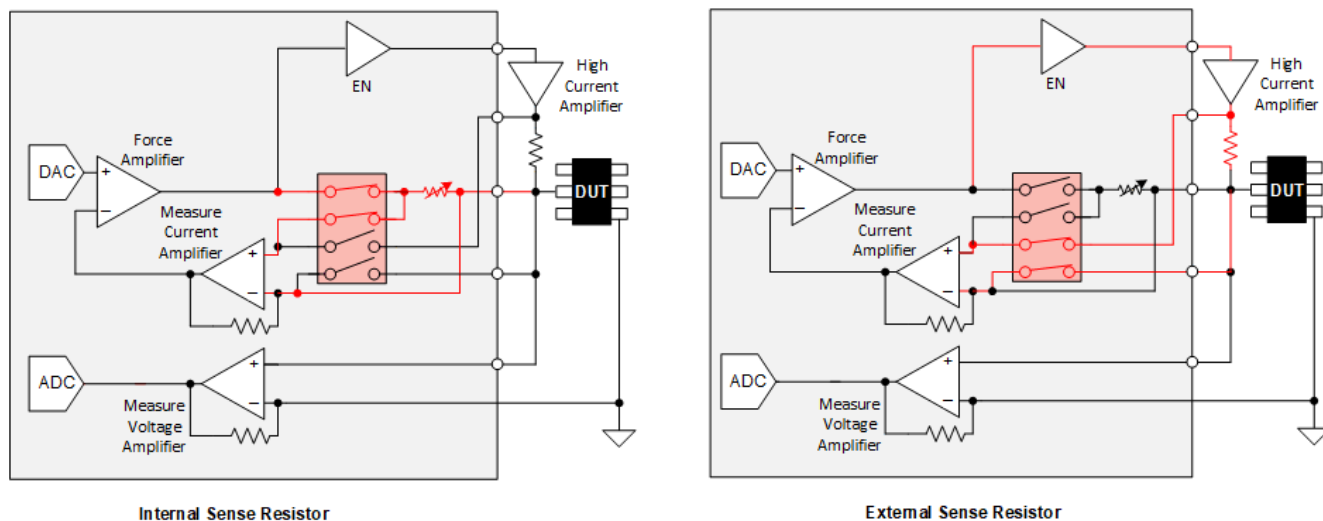

Figure 8-1. High Current Range Selection Using External Resistor

8.2.1 Design Requirements

For this design example, use the parameters listed in [Table 8-1](#).

Table 8-1. Design Parameters

PARAMETERS	VALUES
Supply (V_{DD})	37.5V
Supply (V_{SS})	-12.5V
Input / Output signal range	-7.5V to 32.5V
Control logic thresholds	1.8V compatible

8.2.2 Detailed Design Procedure

Figure 10-1 demonstrates how the TMUXS7614D can be used in semiconductor test equipment for high-precision, high-voltage, multi-channel measurement applications. The TMUXS7614D can support 1.8V logic signals on the control input, allowing the device to interface with low logic controls of an FPGA or MCU. The TMUXS7614D can operate without any external components except for the supply decoupling capacitors. The select pins have an internal pull-down resistor to prevent floating input logic. All inputs to the switch must fall within the recommend operating conditions of the TMUXS7614D including signal range and continuous current. For this design with a positive supply of 37.5V on V_{DD} and negative supply of -12.5V on V_{SS} , the signal range can be 32.5V to -7.5V. The maximum continuous current (I_{DC}) can be up to 470mA as shown in the *Recommended Operating Conditions* table for wide-range current measurement.

8.2.3 Application Curve

The TMUXS7614D have excellent charge injection performance and ultra-low leakage current, making them an excellent choice for minimizing sampling errors for the sample and hold application.

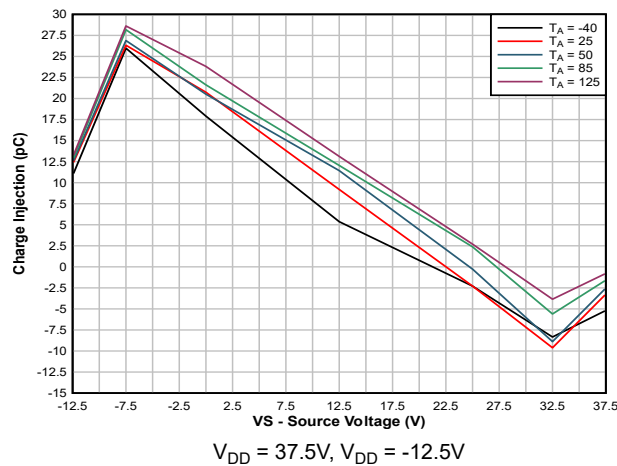

Figure 8-2. Charge Injection vs. Source Voltage

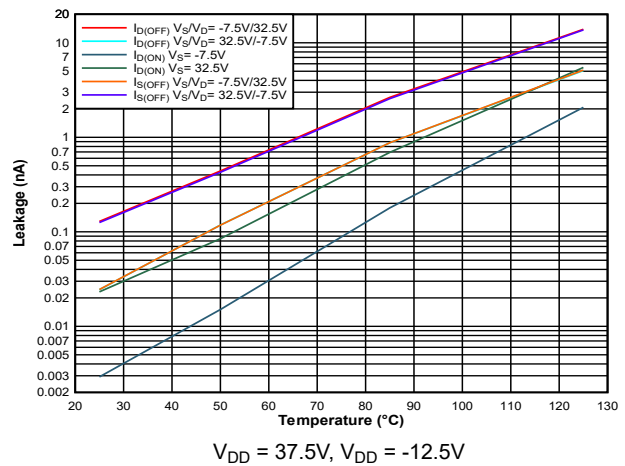
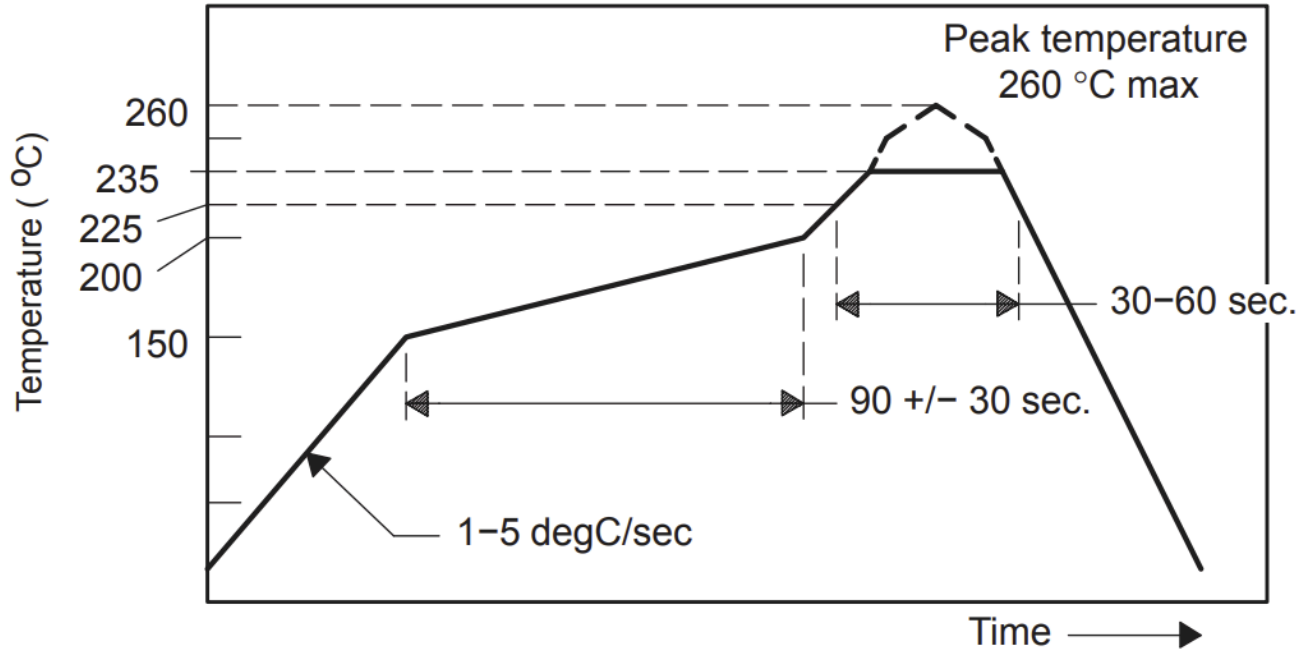

Figure 8-3. On-Leakage vs. Source or Drain Voltage

8.3 Recommended Reflow Profile

TMUXS7614D is in a FCLGA package that has a recommended reflow profile. The below profile can also be found in [Flip Chip Ball Grid Array Package Reference Guide](#) on page 47, along with many tips for assembly. The reflow profile, shown in the image below for SnAgCu solder paste, helps confirm the solder joints in the package have been completely reflowed.



Reflow temperature is defined at package top

Figure 8-4. Recommended Lead-Free Reflow Profile for SnAgCu Solder Paste

8.4 Thermal Considerations

For analog switches in many applications, several 100s of mA of current needs to be supported through the switch (from source to drain, or NO/NC to COM). Many devices already have a maximum current specified based on ambient temperature, but if a device specifies with junction temperature or you want to calculate for your specific use case (temperature, supply voltage, channels in parallel) you can use the following equations and scheme.

There are mainly 2 limitations to this maximum current:

1. Inherent metal limitations of the device
2. Thermal self-heating limitations

To calculate maximum current for your specific setup you need the following information:

- T_A = maximum ambient temperature
- $R_{\theta JA}$ = package thermal coefficients
- R_{ON} = on resistance
- n = number of channels in parallel
- Limitations on maximum current based on junction temperature from the datasheet

Below is an example using TMUXS7614D specifications:

Device maximum $T_J=150^\circ\text{C}$

$R_{\theta JA}=53.5\text{ }^\circ\text{C/W}$

For this example we assume 20°C of self-heating at a maximum $T_A=105^\circ\text{C}$ and operating with 4 channels at once at $\pm 15\text{V}$. We can assume worst case $R_{ON} = 2.2\Omega$. This number is taken from the maximum specified value at $T_A = 125^\circ\text{C}$ where $T_J=125^\circ\text{C}$ since the specification assumes no self-heating. Using the following equation we can calculate the maximum thermal limitation.

$$I = \sqrt{\frac{T_J - T_A}{R_{\theta JA} \times R_{ON} \times n}} \tag{2}$$

The current calculated from this example is 0.206A, but due to the inherent metal limitation we must take the lower of the value calculated and the value provided in the maximum current table based on T_J in the data sheet which is 0.143A in this case. This means that we can only pass a maximum of 0.143A through each of the 4 channels.

As another example where the device is thermally limited: While operating with 8 channels at once at $\pm 15V$ with a maximum $T_A = 50^\circ C$, we can assume worst case $R_{ON} = 2.2\Omega$ by taking the maximum specified value at $T_A = 125^\circ C$ by assuming $55^\circ C$ of self-heating and taking the closest maximum R_{ON} specification to $105^\circ C$. Using the previous equation we can calculate the maximum thermal limitation.

The current calculated from this example is 0.291A which means that we can pass a maximum of 0.291A through each of the 8 channels at once. This means across all 8 channels the device can handle 2.33A total. If we were to only run with one channel then the equation outputs 0.824A, but due to the inherent metal limitation we must take the lower of the value calculated and the value provided in the maximum current table based on T_J in the datasheet which is 0.309A in this case.

Similarly, you can calculate the T_J and total power dissipated in these examples with the following equations. Note there will be some small power dissipated from the supply current consumption of the device, which is ignored here.

$$T_J = R_{\theta JA} \times I^2 \times R_{ON} \times n + T_A \quad (3)$$

$$P_{total} = \frac{T_J - T_A}{R_{\theta JA}} \quad (4)$$

Pulse current can be calculated the same way, but using the duty cycle, d . Typically, pulse current is specified at a 10% duty cycle; however, do not exceed the maximum current provided in the pulse current table even with a shorter duty cycle.

$$I = \frac{1}{d} \sqrt{\frac{T_J - T_A}{R_{\theta JA} \times R_{ON} \times n}} \quad (5)$$

$$T_J = R_{\theta JA} \times (d \times I)^2 \times R_{ON} \times n + T_A \quad (6)$$

8.5 Power Supply Recommendations

The TMUXS7614D device operates across a wide supply range of $\pm 4.5V$ to $\pm 25V$ (4.5V to 42V in single-supply mode). The device also perform well with asymmetrical supplies such as $V_{DD} = 12V$ and $V_{SS} = -5V$.

Power-supply bypassing improves noise margin and prevents switching noise propagation from the supply rails to other components. Good power-supply decoupling is important to achieve optimum performance. TMUXS7614D integrates supply decoupling capacitors so external supply decoupling capacitors at both the V_{DD} , V_L , V_{SS} pins to ground are unnecessary. If the application needs additional bypass capacitors place them as close to the power supply pins of the device as possible using low-impedance connections. TI recommends using multi-layer ceramic chip capacitors (MLCCs) that offer low equivalent series resistance (ESR) and inductance (ESL) characteristics for power-supply decoupling purposes. For very sensitive systems, or for systems in harsh noise environments, avoiding the use of vias for connecting the capacitors to the device pins may offer superior noise immunity. The use of multiple vias in parallel lowers the overall inductance and is beneficial for connections to ground and power planes. Always ensure the ground (GND) connection is established before supplies are ramped.

8.6 Layout

8.6.1 Layout Guidelines

When a PCB trace turns a corner at a 90° angle, a reflection can occur. A reflection occurs primarily because of the change of width of the trace. At the apex of the turn, the trace width increases to 1.414 times the width. This increase upsets the transmission-line characteristics, especially the distributed capacitance and self-inductance of the trace which results in the reflection. Not all PCB traces can be straight; therefore, some traces must turn corners. [Figure 8-5](#) shows progressively better techniques of rounding corners. Only the last example (BEST) maintains constant trace width and minimizes reflections.

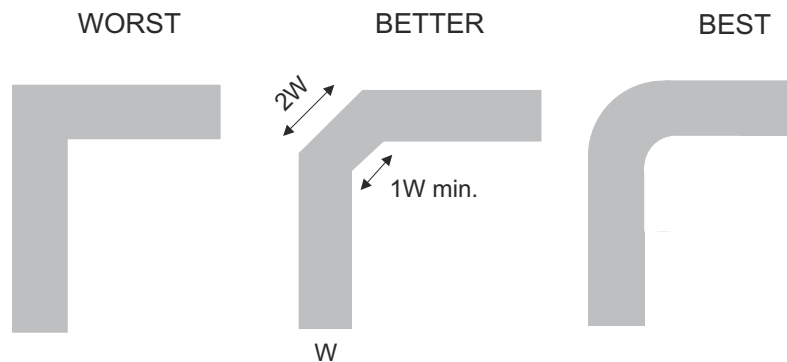

Figure 8-5. Trace Example

Route high-speed signals using a minimum of vias and corners which reduces signal reflections and impedance changes. When a via must be used, increase the clearance size around it to minimize its capacitance. Each via introduces discontinuities in the signal's transmission line and increases the chance of picking up interference from the other layers of the board. Be careful when designing test points; through-hole pins are not recommended at high frequencies.

Some key considerations are as follows:

- Keep the input lines as short as possible.
- Use a solid ground plane to help reduce electromagnetic interference (EMI) noise pickup.
- Do not run sensitive analog traces in parallel with digital traces. Avoid crossing digital and analog traces if possible, and only make perpendicular crossings when necessary.
- Using multiple vias in parallel will lower the overall inductance and is beneficial for connection to ground planes.
- Any precision integrated circuit can experience performance shifts due to moisture ingress into the plastic package. Following any aqueous PCB cleaning process, bake the PCB assembly to remove moisture introduced into the device packaging during the cleaning process. A low temperature, post cleaning bake at 125°C for 1 hour is sufficient for most circumstances.

8.6.2 Layout Example

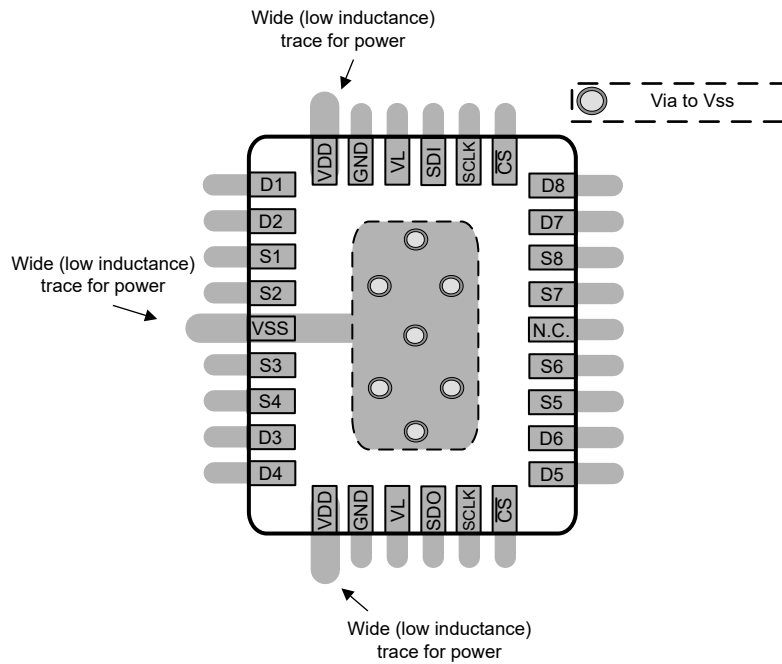

Figure 8-6. TMUXS7614D Layout Example

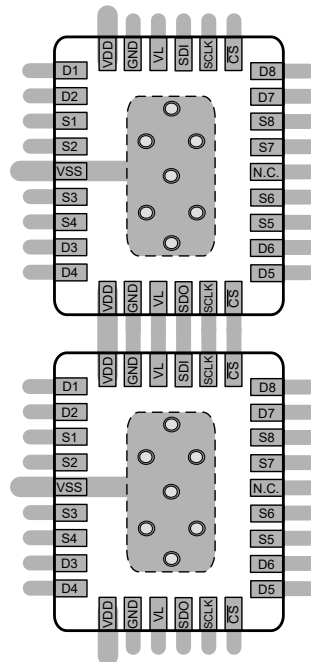

Figure 8-7. TMUXS7614D Daisy-chain Layout Example

9 Device and Documentation Support

9.1 Documentation Support

9.1.1 Related Documentation

For related documentation, see the following:

- Texas Instruments, [When to Replace a Relay with a Multiplexer](#) application brief
- Texas Instruments, [Improving Signal Measurement Accuracy in Automated Test Equipment](#) application brief
- Texas Instruments, [Sample and Hold Glitch Reduction for Precision Outputs Reference Design](#) reference guide
- Texas Instruments, [Simplifying Design with 1.8V logic Muxes and Switches](#) application brief
- Texas Instruments, [System-Level Protection for High-Voltage Analog Multiplexers](#) application note
- Texas Instruments, [QFN/SON PCB Attachment](#) application note

9.2 Receiving Notification of Documentation Updates

To receive notification of documentation updates, navigate to the device product folder on ti.com. Click on *Notifications* to register and receive a weekly digest of any product information that has changed. For change details, review the revision history included in any revised document.

9.3 Support Resources

TI E2E™ support forums are an engineer's go-to source for fast, verified answers and design help — straight from the experts. Search existing answers or ask your own question to get the quick design help you need.

Linked content is provided "AS IS" by the respective contributors. They do not constitute TI specifications and do not necessarily reflect TI's views; see TI's [Terms of Use](#).

9.4 Trademarks

TI E2E™ is a trademark of Texas Instruments.
All trademarks are the property of their respective owners.

9.5 Electrostatic Discharge Caution



This integrated circuit can be damaged by ESD. Texas Instruments recommends that all integrated circuits be handled with appropriate precautions. Failure to observe proper handling and installation procedures can cause damage.

ESD damage can range from subtle performance degradation to complete device failure. Precision integrated circuits may be more susceptible to damage because very small parametric changes could cause the device not to meet its published specifications.

9.6 Glossary

[TI Glossary](#) This glossary lists and explains terms, acronyms, and definitions.

10 Revision History

NOTE: Page numbers for previous revisions may differ from page numbers in the current version.

Changes from Revision D (September 2025) to Revision E (October 2025)	Page
• Updated layout guidelines from "85°C for 30 minutes" to "125°C for 1 hour".....	36

Changes from Revision C (April 2025) to Revision D (September 2025)	Page
• Updated typical plots and added Figure 5-24	17
• Updated layout guidelines with recommendations for device operation in humid environments.....	36

Changes from Revision B (September 2024) to Revision C (April 2025)

- Changed status from Advanced Information to Production Data..... **1**

11 Mechanical, Packaging, and Orderable Information

The following pages include mechanical, packaging, and orderable information. This information is the most current data available for the designated devices. This data is subject to change without notice and revision of this document. For browser-based versions of this data sheet, refer to the left-hand navigation.

11.1 Tape and Reel Information

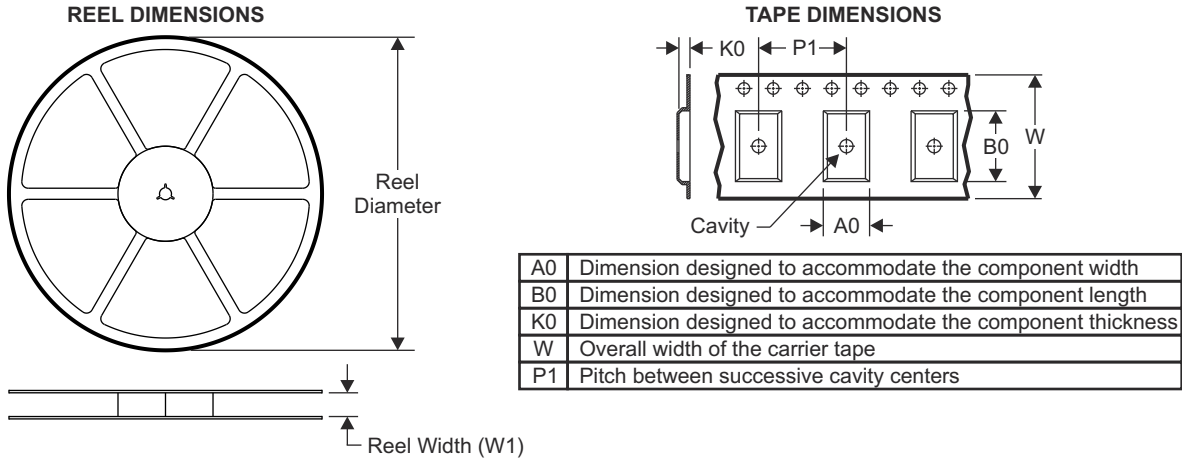

QUADRANT ASSIGNMENTS FOR PIN 1 ORIENTATION IN TAPE

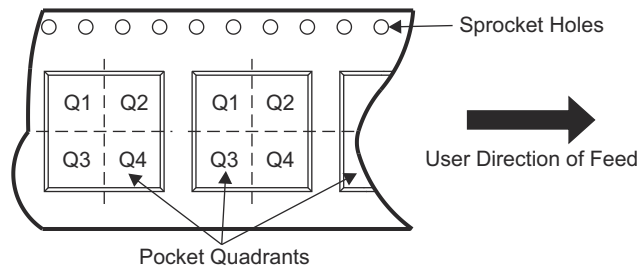

Device	Package Type	Package Drawing	Pins	SPQ	Reel Diameter (mm)	Reel Width W1 (mm)	A0 (mm)	B0 (mm)	K0 (mm)	P1 (mm)	W (mm)	Pin1 Quadrant
TMUXS7614DZEMR	FCLGA	ZEM	30	3000	330	12.4	4.35	5.35	1.3	8	12	Q1

TMUXS7614D

SCDS453E – JUNE 2024 – REVISED OCTOBER 2025

TAPE AND REEL BOX DIMENSIONS

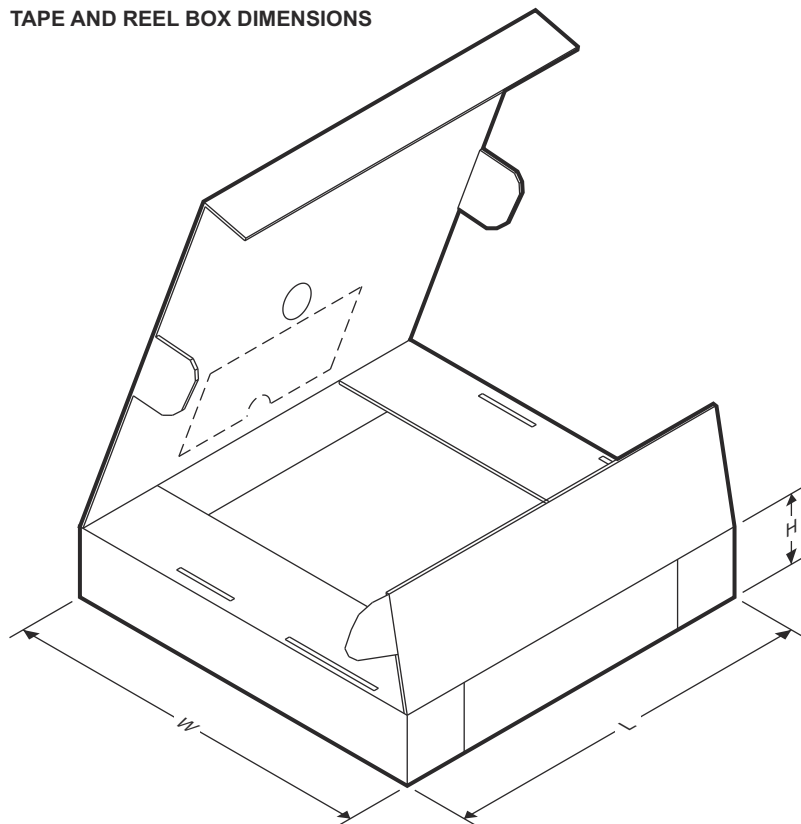

Device	Package Type	Package Drawing	Pins	SPQ	Length (mm)	Width (mm)	Height (mm)
TMUXS7614DZEMR	FCLGA	ZEM	30	3000	470	380	31.8

11.2 Mechanical Data

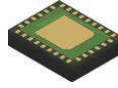

ZEM0030A

PACKAGE OUTLINE

FCLGA - 1.07 mm max height

LAND GRID ARRAY

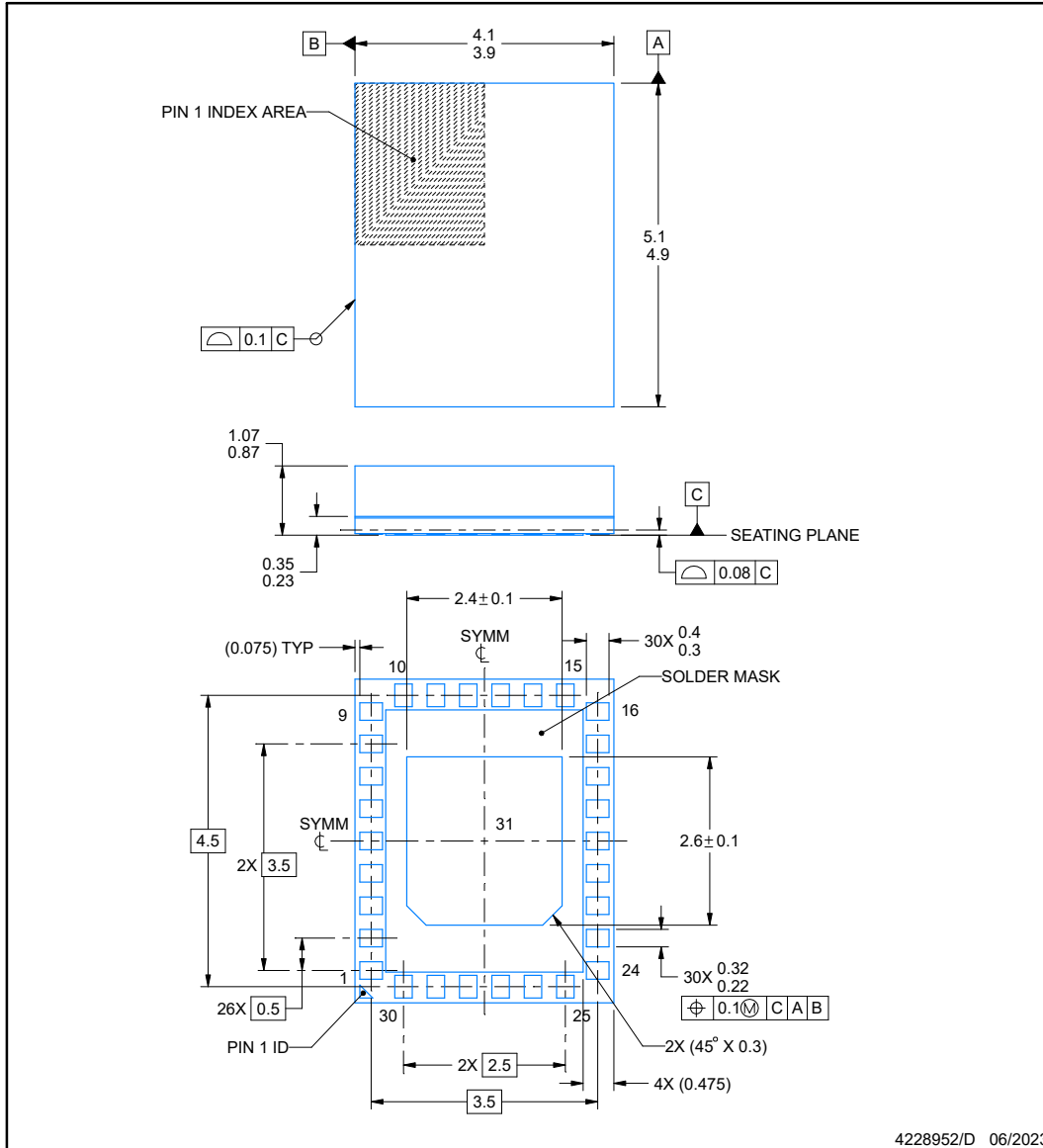

NOTES:

1. All linear dimensions are in millimeters. Any dimensions in parenthesis are for reference only. Dimensioning and tolerancing per ASME Y14.5M.
2. This drawing is subject to change without notice.

EXAMPLE BOARD LAYOUT

ZEM0030A

FCLGA - 1.07 mm max height

LAND GRID ARRAY

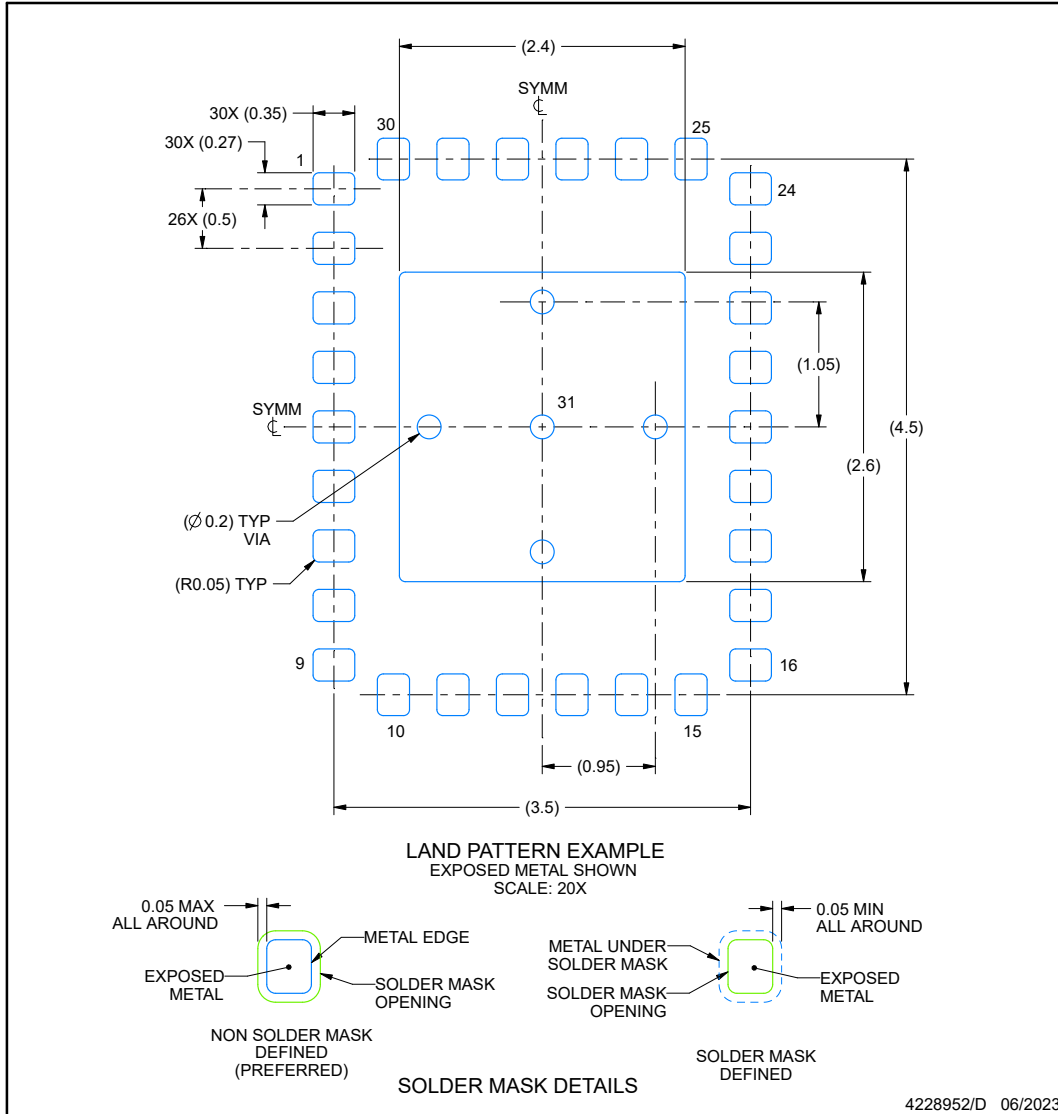

NOTES: (continued)

3. For more information, see Texas Instruments literature number SLUA271 (www.ti.com/lit/slua271).

EXAMPLE STENCIL DESIGN

ZEM0030A

FCLGA - 1.07 mm max height

LAND GRID ARRAY

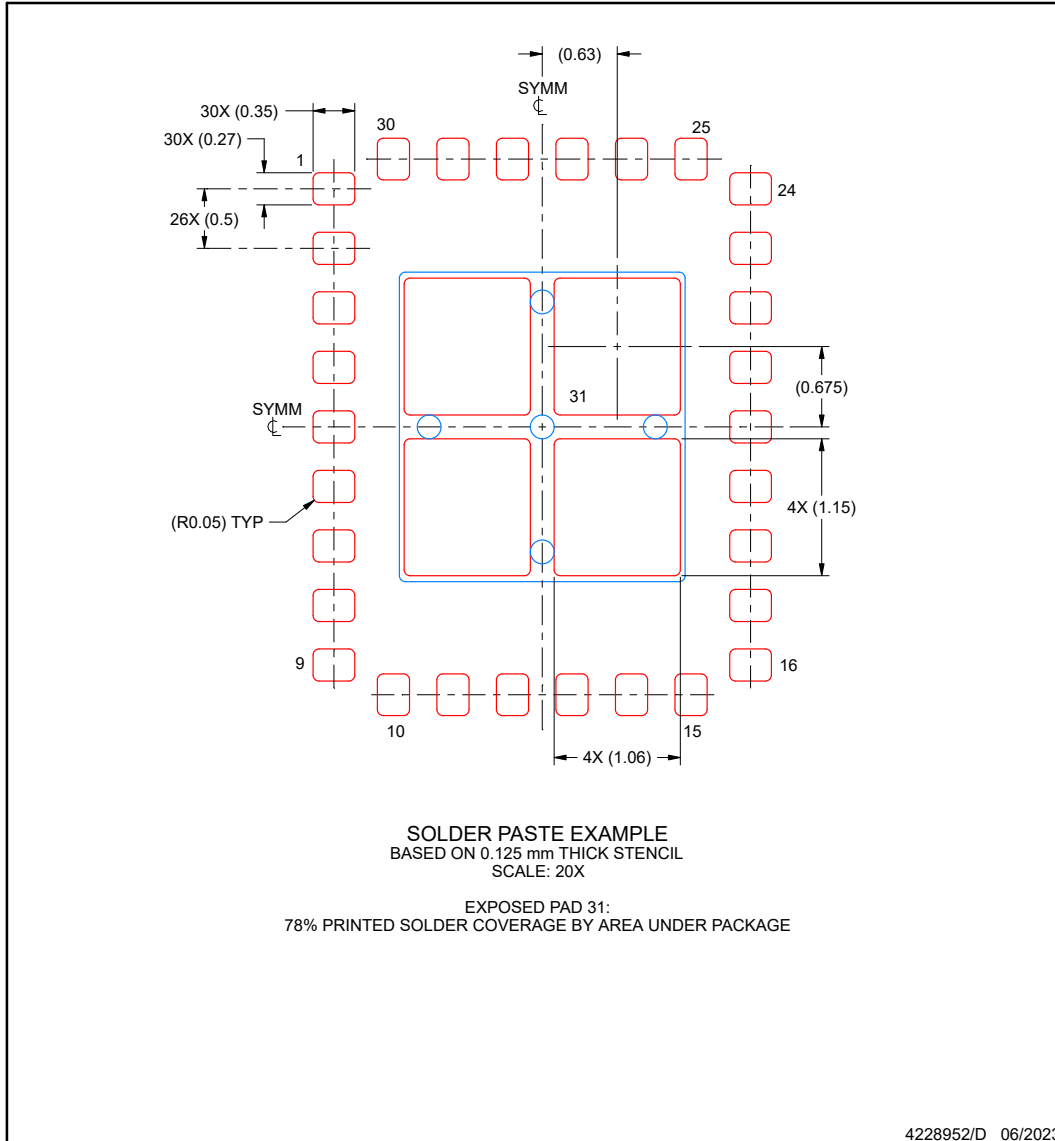

NOTES: (continued)

- 4. Laser cutting apertures with trapezoidal walls and rounded corners may offer better paste release. IPC-7525 may have alternate design recommendations.

PACKAGING INFORMATION

Orderable part number	Status (1)	Material type (2)	Package Pins	Package qty Carrier	RoHS (3)	Lead finish/ Ball material (4)	MSL rating/ Peak reflow (5)	Op temp (°C)	Part marking (6)
PTMUXS7614DZEMR.A	Active	Preproduction	FCLGA (ZEM) 30	3000 LARGE T&R	-	Call TI	Call TI	-40 to 125	
TMUXS7614DZEMR	Active	Production	FCLGA (ZEM) 30	3000 LARGE T&R	Yes	NIAU	Level-3-260C-168 HR	-40 to 125	T7614
TMUXS7614DZEMR.A	Active	Production	FCLGA (ZEM) 30	3000 LARGE T&R	Yes	NIAU	Level-3-260C-168 HR	-40 to 125	T7614

(1) **Status:** For more details on status, see our [product life cycle](#).

(2) **Material type:** When designated, preproduction parts are prototypes/experimental devices, and are not yet approved or released for full production. Testing and final process, including without limitation quality assurance, reliability performance testing, and/or process qualification, may not yet be complete, and this item is subject to further changes or possible discontinuation. If available for ordering, purchases will be subject to an additional waiver at checkout, and are intended for early internal evaluation purposes only. These items are sold without warranties of any kind.

(3) **RoHS values:** Yes, No, RoHS Exempt. See the [TI RoHS Statement](#) for additional information and value definition.

(4) **Lead finish/Ball material:** Parts may have multiple material finish options. Finish options are separated by a vertical ruled line. Lead finish/Ball material values may wrap to two lines if the finish value exceeds the maximum column width.

(5) **MSL rating/Peak reflow:** The moisture sensitivity level ratings and peak solder (reflow) temperatures. In the event that a part has multiple moisture sensitivity ratings, only the lowest level per JEDEC standards is shown. Refer to the shipping label for the actual reflow temperature that will be used to mount the part to the printed circuit board.

(6) **Part marking:** There may be an additional marking, which relates to the logo, the lot trace code information, or the environmental category of the part.

Multiple part markings will be inside parentheses. Only one part marking contained in parentheses and separated by a "-" will appear on a part. If a line is indented then it is a continuation of the previous line and the two combined represent the entire part marking for that device.

Important Information and Disclaimer: The information provided on this page represents TI's knowledge and belief as of the date that it is provided. TI bases its knowledge and belief on information provided by third parties, and makes no representation or warranty as to the accuracy of such information. Efforts are underway to better integrate information from third parties. TI has taken and continues to take reasonable steps to provide representative and accurate information but may not have conducted destructive testing or chemical analysis on incoming materials and chemicals. TI and TI suppliers consider certain information to be proprietary, and thus CAS numbers and other limited information may not be available for release.

In no event shall TI's liability arising out of such information exceed the total purchase price of the TI part(s) at issue in this document sold by TI to Customer on an annual basis.

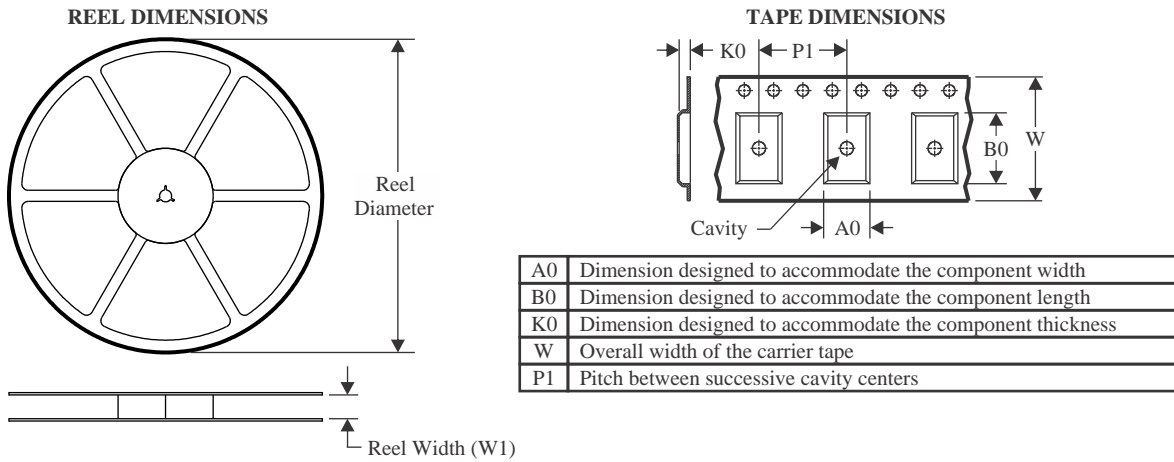
TAPE AND REEL INFORMATION

QUADRANT ASSIGNMENTS FOR PIN 1 ORIENTATION IN TAPE

*All dimensions are nominal

Device	Package Type	Package Drawing	Pins	SPQ	Reel Diameter (mm)	Reel Width W1 (mm)	A0 (mm)	B0 (mm)	K0 (mm)	P1 (mm)	W (mm)	Pin1 Quadrant
TMUXS7614DZEMR	FCLGA	ZEM	30	3000	330.0	12.4	4.35	5.35	1.3	8.0	12.0	Q1

TAPE AND REEL BOX DIMENSIONS

*All dimensions are nominal

Device	Package Type	Package Drawing	Pins	SPQ	Length (mm)	Width (mm)	Height (mm)
TMUXS7614DZEMR	FCLGA	ZEM	30	3000	336.6	336.6	31.8

IMPORTANT NOTICE AND DISCLAIMER

TI PROVIDES TECHNICAL AND RELIABILITY DATA (INCLUDING DATASHEETS), DESIGN RESOURCES (INCLUDING REFERENCE DESIGNS), APPLICATION OR OTHER DESIGN ADVICE, WEB TOOLS, SAFETY INFORMATION, AND OTHER RESOURCES "AS IS" AND WITH ALL FAULTS, AND DISCLAIMS ALL WARRANTIES, EXPRESS AND IMPLIED, INCLUDING WITHOUT LIMITATION ANY IMPLIED WARRANTIES OF MERCHANTABILITY, FITNESS FOR A PARTICULAR PURPOSE OR NON-INFRINGEMENT OF THIRD PARTY INTELLECTUAL PROPERTY RIGHTS.

These resources are intended for skilled developers designing with TI products. You are solely responsible for (1) selecting the appropriate TI products for your application, (2) designing, validating and testing your application, and (3) ensuring your application meets applicable standards, and any other safety, security, regulatory or other requirements.

These resources are subject to change without notice. TI grants you permission to use these resources only for development of an application that uses the TI products described in the resource. Other reproduction and display of these resources is prohibited. No license is granted to any other TI intellectual property right or to any third party intellectual property right. TI disclaims responsibility for, and you fully indemnify TI and its representatives against any claims, damages, costs, losses, and liabilities arising out of your use of these resources.

TI's products are provided subject to [TI's Terms of Sale](#), [TI's General Quality Guidelines](#), or other applicable terms available either on [ti.com](#) or provided in conjunction with such TI products. TI's provision of these resources does not expand or otherwise alter TI's applicable warranties or warranty disclaimers for TI products. Unless TI explicitly designates a product as custom or customer-specified, TI products are standard, catalog, general purpose devices.

TI objects to and rejects any additional or different terms you may propose.

Copyright © 2026, Texas Instruments Incorporated

Last updated 10/2025