

# TPS54202x 4.5V to 30V, 2A, EMI Friendly, Synchronous Step-Down Converter

## 1 Features

- Configured for a wide range of applications
  - Input voltage range: 4.5V to 30V
  - Selectable adjustable output (TPS542021), fixed 5V output (TPS542025)
  - Continuous output current: up to 2A
  - Reference voltage:  $0.6V \pm 1.5%$  ( $25^{\circ}C$ )
  - Supports low drop out mode
- High efficiency
  - Integrated MOSFETs: 100mΩ and 60mΩ
  - Low 2μA shutdown, 26μA quiescent current
  - Pulse frequency modulation (PFM) for high light load efficiency
- Ease of use
  - Peak current mode control with internal loop compensation
  - Fixed switching frequency: 500kHz
  - Internal soft start: 5ms
  - Frequency spread spectrum to reduce EMI
  - Overcurrent protection for both MOSFETs with hiccup mode protection
  - Non-latched protection for over temperature protection (OTP), overcurrent protection (OCP), overvoltage protection (OVP), and undervoltage lockout (UVLO)
  - P2P, B2B with TPS54202
  - SOT-23 (6), SOT-563 package

## 2 Applications

- 12V, 24V distributed power-bus supply
- Industry application
  - White goods
- Consumer application
  - Set-Top Box (STB), Digital Television (DTV)
  - Printer

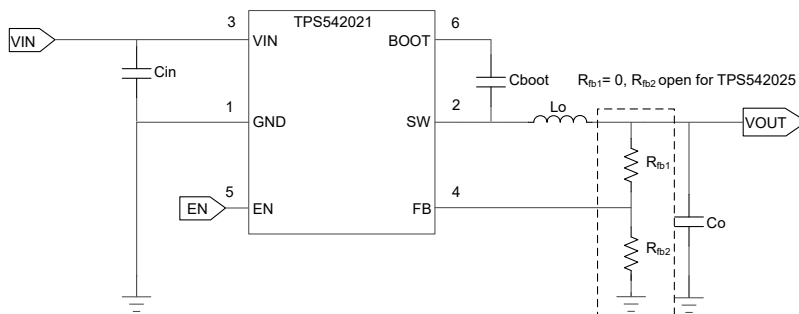

TPS54202x Simplified Schematic

## 3 Description

The TPS54202x is a 4.5V to 30V input voltage range, 2A output, synchronous buck converter. The device includes two integrated switching FETs, internal loop compensation and 5ms internal soft start to reduce component count.

By integrating the MOSFETs, the TPS54202x achieves the high power density and offers a small footprint on the PCB. TPS542025 has fixed 5V output, which saves BOM by further reducing FB resistors. TPS542021 has adjustable output by a different FB resistor configuration.

The TPS54202x operates in pulse frequency modulation for higher light load efficiency and reduces the power loss. The frequency spread spectrum operation is introduced for Electromagnetic Interference (EMI) reduction.

Cycle-by-cycle current limit in both high-side MOSFET protects the converter in an overload condition and is enhanced by a low-side MOSFET freewheeling current limit which prevents current runaway. Hiccup mode protection is triggered if the overcurrent condition has persisted for longer than the present time.

### Device Information

PART NUMBER	PACKAGE <sup>(1)</sup>	PACKAGE SIZE <sup>(2)</sup>
TPS542021	DDC (SOT-23-THN, 6)	2.9mm × 2.8mm
	DRL (SOT-563, 6)	1.60mm × 1.60mm
TPS542025	DDC (SOT-23-THN, 6)	2.9mm × 2.8mm
	DRL (SOT-563, 6)	1.60mm × 1.60mm

(1) For more information, see Section 10.

(2) The package size (length × width) is a nominal value and includes pins, where applicable.

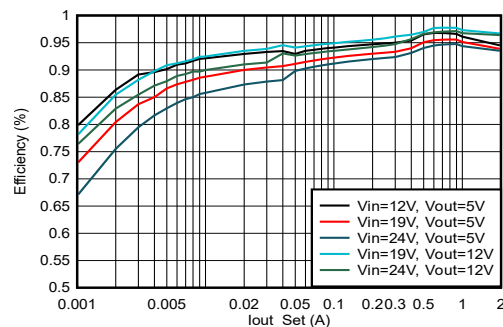

Efficiency vs Output Current



## Table of Contents

<b>1 Features</b> .....	<b>1</b>	<b>7 Application and Implementation</b> .....	<b>14</b>
<b>2 Applications</b> .....	<b>1</b>	7.1 Application Information.....	14
<b>3 Description</b> .....	<b>1</b>	7.2 Typical Application.....	14
<b>4 Pin Configuration and Functions</b> .....	<b>3</b>	7.3 Power Supply Recommendations.....	21
<b>5 Specifications</b> .....	<b>4</b>	7.4 Layout.....	21
5.1 Absolute Maximum Ratings.....	4	<b>8 Device and Documentation Support</b> .....	<b>22</b>
5.2 ESD Ratings.....	4	8.1 Device Support.....	22
5.3 Recommended Operating Conditions.....	4	8.2 Documentation Support.....	22
5.4 Thermal Information.....	4	8.3 Receiving Notification of Documentation Updates....	22
5.5 Electrical Characteristics.....	5	8.4 Support Resources.....	22
5.6 Typical Characteristics.....	7	8.5 Trademarks.....	22
<b>6 Detailed Description</b> .....	<b>8</b>	8.6 Electrostatic Discharge Caution.....	22
6.1 Overview.....	8	8.7 Glossary.....	22
6.2 Functional Block Diagram.....	9	<b>9 Revision History</b> .....	<b>23</b>
6.3 Feature Description.....	9	<b>10 Mechanical, Packaging, and Orderable Information</b> .....	<b>23</b>
6.4 Device Functional Modes.....	12		

## 4 Pin Configuration and Functions

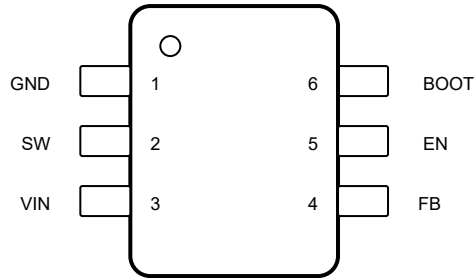

**Figure 4-1. 6-Pin SOT-23 DDC Package (Top View)**

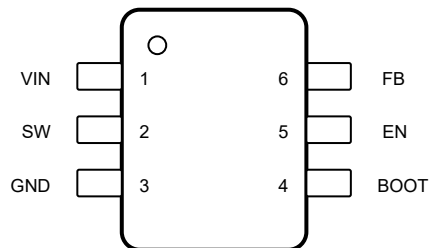

**Figure 4-2. 6-Pin SOT-563 DRL Package (Top View)**

**Table 4-1. Pin Functions**

NAME	PIN NO.		TYPE <sup>(1)</sup>	DESCRIPTION
	SOT-23	SOT-563		
BOOT	6	4	O	Supply input for the high-side NFET gate drive circuit. Connect a 0.1µF capacitor between BOOT and SW pins.
EN	5	5	I	Enable control for device output. Connect to 5V or leave this pin floating to enable device output. Connect to GND to disable the device output.
FB	4	6	I	Converter feedback input. Connect to output voltage with feedback resistor divider for TPS542021, connect to output capacitors to get fixed 5V output for TPS542025.
GND	1	3	—	Ground pin.
SW	2	2	O	Switch node connection between high-side NFET and low-side NFET.
VIN	3	1	—	Input voltage supply pin.

(1) O = Output; I = Input

## 5 Specifications

### 5.1 Absolute Maximum Ratings

Over the recommended operating junction temperature range of  $-40^{\circ}\text{C}$  to  $+150^{\circ}\text{C}$ , unless otherwise noted<sup>(1)</sup>

		MIN	MAX	UNIT
Input voltage range, $V_I$	VIN	-0.3	32	V
	EN	-0.3	7	V
	FB	-0.3	7	V
Output voltage range, $V_O$	BOOT-SW	-0.3	7	V
	SW	-0.3	32	V
	SW (20ns transient)	-5	32	V
Operating junction temperature <sup>(2)</sup> , $T_J$		-40	150	$^{\circ}\text{C}$
Storage temperature range, $T_{\text{stg}}$		-65	150	$^{\circ}\text{C}$

- (1) Operation outside the *Absolute Maximum Ratings* may cause permanent device damage. *Absolute Maximum Ratings* do not imply functional operation of the device at these or any other conditions beyond those listed under Recommended Operating Conditions. If used outside the *Recommended Operating Conditions* but within the *Absolute Maximum Ratings*, the device may not be fully functional, and this may affect device reliability, functionality, performance, and shorten the device lifetime.
- (2) Operating at junction temperatures greater than  $150^{\circ}\text{C}$ , although possible, degrades the lifetime of the device.

### 5.2 ESD Ratings

			VALUE	UNIT
$V_{\text{(ESD)}}$	Electrostatic discharge	Human-body model (HBM), per ANSI/ESDA/JEDEC JS-001 <sup>(1)</sup>	$\pm 2500$	V
		Charged-device model (CDM), per ANSI/ESDA/JEDEC JS-002, all pins <sup>(2)</sup>	$\pm 1500$	

- (1) JEDEC document JEP155 states that 500V HBM allows safe manufacturing with a standard ESD control process.
- (2) JEDEC document JEP157 states that 250V CDM allows safe manufacturing with a standard ESD control process.

### 5.3 Recommended Operating Conditions

over operating free-air temperature range (unless otherwise noted)

		MIN	MAX	UNIT	
$V_I$	Input voltage range	VIN	4.5	30	V
		EN	-0.1	5.5	V
		FB	-0.1	5.5	V
$V_O$	Output voltage range	BOOT-SW	-0.1	5.5	V
		SW	-0.1	30	V
$T_J$	Operating junction temperature	-40	150	$^{\circ}\text{C}$	

### 5.4 Thermal Information

THERMAL METRIC <sup>(1)</sup>		TPS54202x		UNIT
		DDC (SOT-23-THN, 6)		
		JEDEC <sup>(2)</sup>	EVM <sup>(3)</sup>	
$R_{\theta JA}$	Junction-to-ambient thermal resistance	118.6	N/A	$^{\circ}\text{C}/\text{W}$
$R_{\theta JC(\text{top})}$	Junction-to-case (top) thermal resistance	63.6	N/A	$^{\circ}\text{C}/\text{W}$
$R_{\theta JB}$	Junction-to-board thermal resistance	34.4	N/A	$^{\circ}\text{C}/\text{W}$
$\Psi_{JT}$	Junction-to-top characterization parameter	18.5	N/A	$^{\circ}\text{C}/\text{W}$
$\Psi_{JB}$	Junction-to-board characterization parameter	33.7	N/A	$^{\circ}\text{C}/\text{W}$
$R_{\theta JA\_EVM}$	Junction-to-ambient thermal resistance on official EVM board	N/A	57.2	$^{\circ}\text{C}/\text{W}$

- (1) For more information about traditional and new thermal metrics, see the [Semiconductor and IC Package Thermal Metrics](#) application note.

- (2) The value of  $R_{\theta JA}$  given in this table is only valid for comparison with other packages and can not be used for design purposes. These values were simulated on a standard JEDEC board. These values do not represent the performance obtained in an actual application.
- (3) The real  $R_{\theta JA}$  is tested on TI EVM.

## 5.5 Electrical Characteristics

The electrical ratings specified in this section apply to all specifications in this document unless otherwise noted. Typical values correspond to  $T_J = 25^\circ\text{C}$ ,  $V_{IN} = 12\text{V}$ . Minimum and maximum limits are based on  $T_J = -40^\circ\text{C}$  to  $+150^\circ\text{C}$ ,  $V_{IN} = 4.5\text{V}$  to  $30\text{V}$  (unless otherwise noted).

PARAMETER		TEST CONDITIONS	MIN	TYP	MAX	UNIT
<b>SUPPLY</b>						
$I_{Q(VIN)}$	VIN quiescent current at Eco-mode	Non-switching, $V_{IN} = 12\text{V}$ , $V_{EN} = 5\text{V}$ , $V_{FB} = 1\text{V}$ , $I_{OUT} = 0\text{mA}$		26		$\mu\text{A}$
$I_{SD(VIN)}$	VIN shutdown supply current	$V_{IN} = 12\text{V}$ , $V_{EN} = 0\text{V}$		3		$\mu\text{A}$
<b>UVLO</b>						
$V_{UVLO(R)}$	VIN UVLO rising threshold	$V_{IN}$ rising	3.9	4.2	4.4	V
$V_{UVLO(F)}$	VIN UVLO falling threshold	$V_{IN}$ falling	3.4	3.7	3.9	V
$V_{UVLO(H)}$	VIN UVLO hysteresis		400	480	560	mV
<b>ENABLE</b>						
$V_{EN(R)}$	EN voltage rising threshold	EN rising, enable switching		1.21	1.28	V
$V_{EN(F)}$	EN voltage falling threshold	EN falling, disable switching	1.1	1.19		V
$I_{EN(P)}$	EN pin sourcing current	$V_{EN} = 1.1\text{V}$		0.7		$\mu\text{A}$
$I_{EN(H)}$	EN pin sourcing current hysteresis	$V_{EN} = 1.5\text{V}$		1.55		$\mu\text{A}$
<b>REFERENCE VOLTAGE</b>						
$V_{FB}$	FB voltage TPS542025	$T_J = 25^\circ\text{C}$	4.925	5	5.075	V
		$T_J = 0^\circ\text{C}$ to $85^\circ\text{C}$		5		V
		$T_J = -40^\circ\text{C}$ to $150^\circ\text{C}$	4.9	5	5.1	V
$V_{FB}$	FB voltage TPS542021	$T_J = 25^\circ\text{C}$	590	596	602	mV
$V_{FB}$	FB voltage TPS542021	$T_J = 0^\circ\text{C}$ to $85^\circ\text{C}$		596		mV
$V_{FB}$	FB voltage TPS542021	$T_J = -40^\circ\text{C}$ to $150^\circ\text{C}$	587	596	605	mV
<b>STARTUP</b>						
$t_{SS}$	Internal fixed soft-start time	From $0.1 \times V_{OUT}$ to $0.9 \times V_{OUT}$		5		ms
<b>SWITCHING FREQUENCY</b>						
<b>POWER STAGE</b>						
$R_{DSON(HS)}$	High-side MOSFET On-resistance	$V_{BOOT-SW} = 5\text{V}$		100		m $\Omega$
$R_{DSON(LS)}$	Low-side MOSFET On-resistance			60		m $\Omega$
$f_{SW}$	Switching frequency		390	500	630	kHz
$t_{ON(\min)}^{(1)}$	Minimum ON pulse width			70		ns
<b>OVERCURRENT PROTECTION</b>						
$I_{HS(OC)}$	High-side peak current limit 2A	Peak current limit on HS MOSFET	2.5	3.2	3.9	A
$I_{LS(OC)}$	Low-side valley current limit 2A	Valley current limit on LS MOSFET	2	3	4.3	A
$I_{LPEAK(\min)}$	Power save mode peak inductor current threshold			0.75		A
<b>OUTPUT OVP AND UVP</b>						
$V_{OVP}$	Overvoltage-protection (OVP) threshold voltage	$V_{FB}$ rising		108		%
		OVP Hysteresis		4		%
$t_{HIC(WAIT)}$	Wait time before entering Hiccup			512		cycles
$t_{HIC(RE)}$	Hiccup time before restart			16384		cycles
<b>THERMAL SHUTDOWN</b>						
$T_{J(SD)}^{(1)}$	Thermal shutdown threshold			160		$^\circ\text{C}$

## 5.5 Electrical Characteristics (continued)

The electrical ratings specified in this section apply to all specifications in this document unless otherwise noted. Typical values correspond to  $T_J = 25^\circ\text{C}$ ,  $V_{IN} = 12\text{V}$ . Minimum and maximum limits are based on  $T_J = -40^\circ\text{C}$  to  $+150^\circ\text{C}$ ,  $V_{IN} = 4.5\text{V}$  to  $30\text{V}$  (unless otherwise noted).

PARAMETER		TEST CONDITIONS	MIN	TYP	MAX	UNIT
$T_{J(\text{HYS})}$ <sup>(1)</sup>	Thermal shutdown hysteresis			10		$^\circ\text{C}$
$t_{\text{HICCUP}}$	Hiccup time			32768		Cycles
<b>FREQUENCY SPREAD SPECTRUM</b>						
$f_{\text{FSS}}$	Swing frequency			$f_{\text{SW}}/512$		kHz
$f_{\text{SPREAD}}$	Spread of internal oscillator with spread spectrum enabled			$\pm 6$		%

(1) Not production tested

### 5.6 Typical Characteristics

$V_{IN} = 12V$ ,  $T_A = 25^\circ C$ , unless otherwise specified.

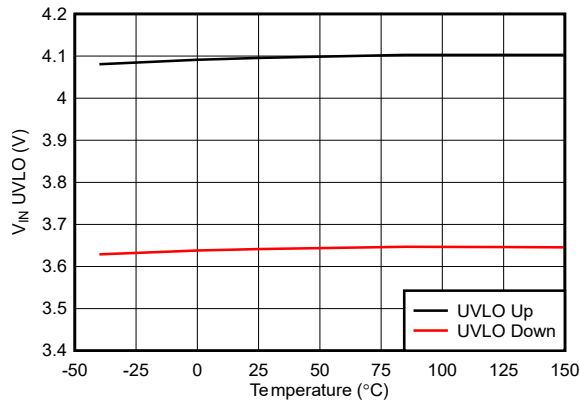

Figure 5-1.  $V_{IN}$  UVLO Threshold

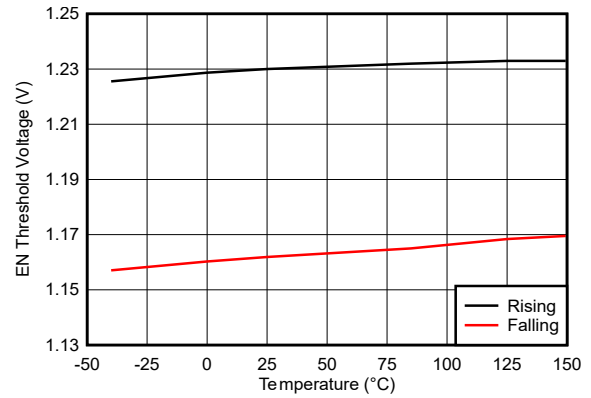

Figure 5-2. EN Threshold

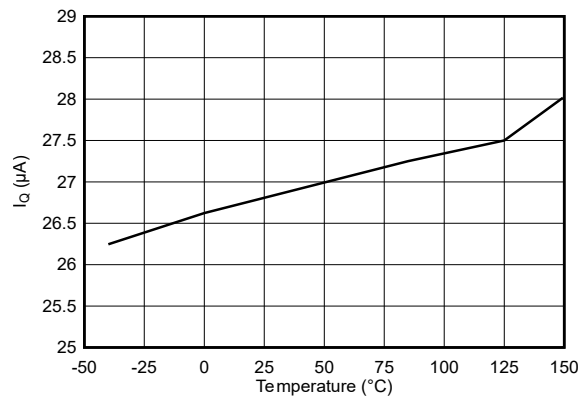

Figure 5-3. Non-Switching  $I_Q$

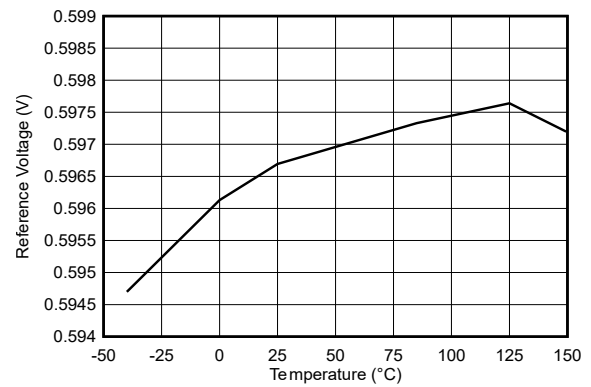

Figure 5-4. Reference Voltage

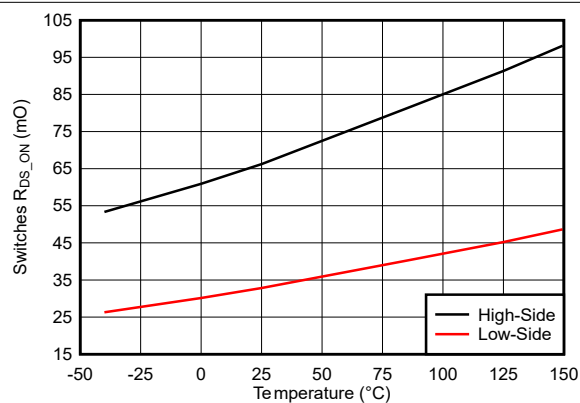

Figure 5-5. High-Side and Low-Side Switches  $R_{DS\_ON}$

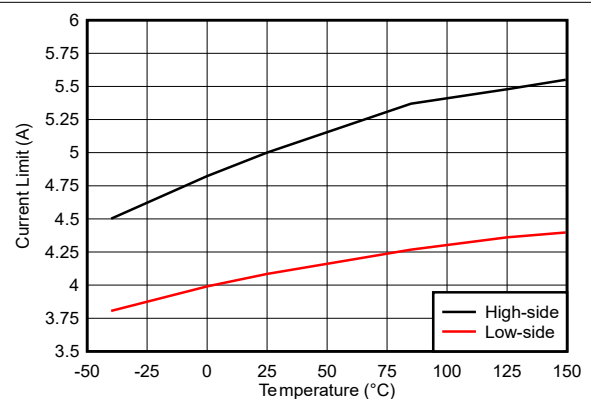

Figure 5-6. High-Side and Low-Side Current Limit

## 6 Detailed Description

### 6.1 Overview

The TPS54202x family of devices is 4.5V to 30V input, 2A output, synchronous step-down (buck) converter with two integrated n-channel MOSFETs. To improve performance during line and load transients the device implements a constant-frequency, peak current mode control which reduces output capacitance. The devices operate in pulse frequency modulation for higher light load efficiency and reduces the power loss. The switching frequency is fixed to 500kHz. The TPS542025 has fixed 5V output while TPS542021 has adjustable output. The optimized internal compensation network minimizes the external component counts and simplifies the control loop design.

The device begins switching at  $V_{IN}$  equal to 4.5V. The operating current is 26 $\mu$ A typically when not switching and under no load. When the device is disabled, the supply current is 2 $\mu$ A typically.

The integrated 100m $\Omega$  high-side MOSFET and 60m $\Omega$  allow for high efficiency power supply designs with continuous output currents up to 2A.

The device reduces the external component count by integrating the boot recharge diode. The bias voltage for the integrated high-side MOSFET is supplied by an external capacitor on the BOOT to PH pins. The boot capacitor voltage is monitored by an UVLO circuit and turns the high-side MOSFET off when the voltage falls below a preset threshold of 2.1V typically.

The frequency spread spectrum operation is introduced for Electromagnetic Interference (EMI) reduction.

The device minimizes excessive output overvoltage transients by taking advantage of the overvoltage comparator. When the regulated output voltage is greater than 108% of the nominal voltage, the overvoltage comparator is activated, and the high-side MOSFET is turned off and masked from turning on until the output voltage is lower than 104%.

The device has internal 5ms soft-start time to minimize inrush currents.

## 6.2 Functional Block Diagram

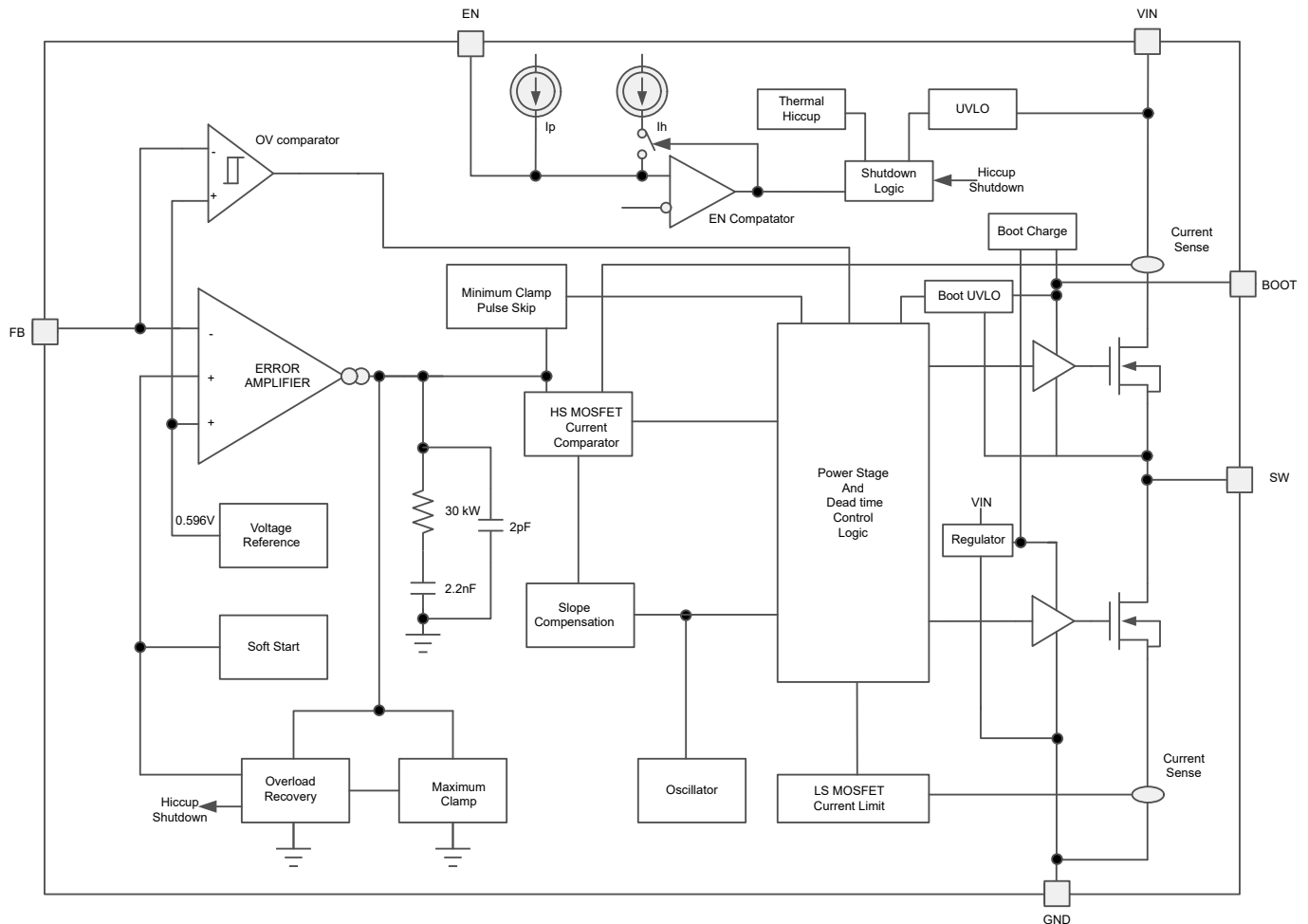

## 6.3 Feature Description

### 6.3.1 Fixed-Frequency PWM Control

The device uses a fixed-frequency, peak current-mode control. For TPS542025, the output voltage is fixed 5V by connecting the FB pin to V<sub>OUT</sub>. For TPS542021, the output voltage is compared through external resistors on the FB pin to an internal voltage reference by an error amplifier. A voltage feedback loop is used to get accurate DC voltage regulation by adjusting the peak current command based on voltage offset. The peak inductor current is sensed from the HS switch and compared to the peak current threshold to control the on time of the HS switch. The voltage feedback loop is internally compensated, which allows for fewer external components, makes design easy, and provides stable operation with almost any combination of output capacitors.

The TPS54202x supplies a regulated output voltage by turning on the HS and LS NMOS switches with controlled duty cycle. During high-side switch on time, the SW pin voltage swings up to approximately V<sub>IN</sub>, and the inductor current, i<sub>L</sub>, increases with linear slope (V<sub>IN</sub> – V<sub>OUT</sub>) / L. When the HS switch is turned off by the control logic, the LS switch is turned on after an anti-shoot-through dead time. Inductor current discharges through the low-side switch with a slope of –V<sub>OUT</sub> / L. The control parameter of a buck converter is defined as Duty Cycle D = t<sub>ON</sub> / t<sub>SW</sub>, where t<sub>ON</sub> is the high-side switch on time and t<sub>SW</sub> is the switching period. The converter control loop maintains a constant output voltage by adjusting the duty cycle D. In an ideal buck converter where losses are ignored, D is proportional to the output voltage and inversely proportional to the input voltage: D = V<sub>OUT</sub> / V<sub>IN</sub>.

### 6.3.2 Pulse Frequency Modulation

The TPS54202x is designed to operate in pulse frequency mode at light load currents to boost light load efficiency. When the peak inductor current is lower than 750mA typically, the device enters Pulse Frequency Modulation (PFM) mode.

In PFM mode, the switching frequency reduces with load to minimize switching losses at lower loads. When the device is in PFM mode, the error amplifier output voltage is clamped which prevents the high side integrated MOSFET from switching.

### 6.3.3 Error Amplifier

The device has a trans-conductance amplifier as the error amplifier. The error amplifier compares the FB voltage to the lower of the internal soft-start voltage or the internal 0.596V voltage reference. The transconductance of the error amplifier is 240 $\mu$ A/V typically. The frequency compensation components are placed internal between the output of the error amplifier and ground.

### 6.3.4 Slope Compensation and Output Current

The device adds a compensating ramp to the signal of the switch current. This slope compensation prevents sub-harmonic oscillations as the duty cycle increases. The available peak inductor current remains constant over the full duty-cycle range.

### 6.3.5 Enable and Adjusting Undervoltage Lockout

The EN pin provides electrical on and off control of the device. When the EN pin voltage exceeds the threshold voltage, the device begins operation. If the EN pin voltage is pulled below the threshold voltage, the regulator stops switching and enters the low-quiescent (IQ) state.

The EN pin has an internal pullup-current source, which allows the user to float the EN pin to enable the device. If an application requires control of the EN pin, use open-drain or open-collector output logic to interface with the pin.

The device implements internal undervoltage-lockout (UVLO) circuitry on the VIN pin. The device is disabled when the VIN pin voltage falls below the internal VIN UVLO threshold. The internal VIN UVLO threshold has a hysteresis of 480mV.

If an application requires a higher UVLO threshold on the VIN pin, then the EN pin can be configured as shown in [Figure 6-1](#). When using the external UVLO function, TI recommends setting the hysteresis at a value greater than 500mV.

The EN pin has a small pullup current,  $I_p$ , which sets the default state of the pin to enable when no external components are connected. The pullup current is also used to control the voltage hysteresis for the UVLO function because the pullup current increases by  $I_h$  when the EN pin crosses the enable threshold. Use [Equation 1](#) and [Equation 2](#) to calculate the values of R4 and R5 for a specified UVLO threshold.

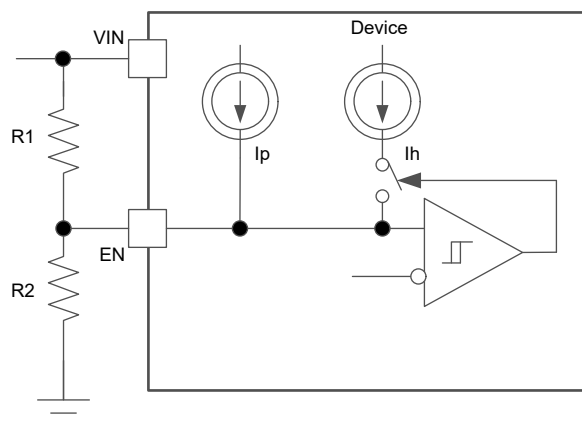

**Figure 6-1. Adjustable VIN Undervoltage Lockout**

$$R_4 = \frac{\frac{V_{ENfalling}}{V_{ENrising}} \times V_{START} - V_{STOP}}{I_p \times \left(1 - \frac{V_{ENfalling}}{V_{ENrising}}\right) + I_h} \quad (1)$$

$$R_5 = \frac{R_4 \times V_{ENfalling}}{V_{STOP} - V_{ENfalling} + (I_h + I_p) \times R_4} \quad (2)$$

Where:

- $I_p = 0.7\mu\text{A}$
- $I_h = 1.55\mu\text{A}$
- $V_{ENfalling} = 1.19\text{V}$
- $V_{ENrising} = 1.22\text{V}$

### 6.3.6 Safe Start-Up into Prebiased Outputs

The device has been designed to prevent the low-side MOSFET from discharging a prebiased output. During monotonic prebiased start-up, both high-side and low-side MOSFETs are not allowed to be turned on until the internal soft-start voltage is higher than the FB pin voltage.

### 6.3.7 Voltage Reference

The voltage reference system produces a precise  $\pm 2\%$  voltage-reference overtemperature by scaling the output of a temperature stable band-gap circuit. The typical voltage reference is designed at 0.596V.

### 6.3.8 Adjusting Output Voltage

The output voltage is set with a resistor divider from the output node to the FB pin. TI recommends to use divider resistors with 1% tolerance or better. Start with a 100k $\Omega$  for the upper resistor divider, and use [Equation 3](#) to calculate the output voltage. To improve efficiency at light loads consider using larger value resistors. If the values are too high the regulator is more susceptible to noise and voltage errors from the FB input current are noticeable.

$$V_{OUT} = V_{ref} \times \left(\frac{R_2}{R_3} + 1\right) \quad (3)$$

### 6.3.9 Internal Soft Start

The TPS54202x uses the internal soft-start function. The internal soft start time is set to 5ms typically.

### 6.3.10 Bootstrap Voltage (BOOT)

The TPS54202x has an integrated boot regulator and requires a 0.1 $\mu\text{F}$  ceramic capacitor between the BOOT and SW pins to provide the gate drive voltage for the high-side MOSFET. A ceramic capacitor with an X7R or X5R grade dielectric is recommended because of the stable characteristics over temperature and voltage. To improve drop out, the device is designed to operate at 100% duty cycle as long as the BOOT to SW pin voltage is greater than 2.1V typically.

### 6.3.11 Overcurrent Protection

The device is protected from overcurrent conditions by cycle-by-cycle current limiting on both the high-side MOSFET and the low-side MOSFET.

#### 6.3.11.1 High-Side MOSFET Overcurrent Protection

The device implements current mode control which uses the internal COMP voltage to control the turn off of the high-side MOSFET and the turn on of the low-side MOSFET on a cycle-by-cycle basis. During each cycle, the switch current and the current reference generated by the internal COMP voltage are compared. When the peak switch current intersects the current reference, the high-side switch turns off.

### 6.3.11.2 Low-Side MOSFET Overcurrent Protection

While the low-side MOSFET is turned on, the conduction current is monitored by the internal circuitry. During normal operation, the low-side MOSFET sources current to the load. At the end of every clock cycle, the low-side MOSFET sourcing current is compared to the internally set low-side sourcing current-limit. The inductor valley current is exceeded the low-side source current limit, the high-side MOSFET does not turn on and the low-side MOSFET stays on for the next cycle. The high-side MOSFET turns on again when the inductor valley current is below the low-side sourcing current-limit at the start of a cycle.

Furthermore, if an output overload condition occurs for more than the hiccup wait time, which is programmed for 512 switching cycles, the device shuts down and restarts after the hiccup time of 16384 cycles. The hiccup mode helps to reduce the device power dissipation under severe overcurrent conditions.

### 6.3.12 Spread Spectrum

To reduce EMI, TPS54202x introduces frequency spread spectrum. The jittering span is  $\pm 6\%$  of the switching frequency with  $1/512$  swing frequency. The purpose of spread spectrum is to eliminate peak emissions at specific frequencies by spreading emissions across a wider range of frequencies than a part with fixed frequency operation.

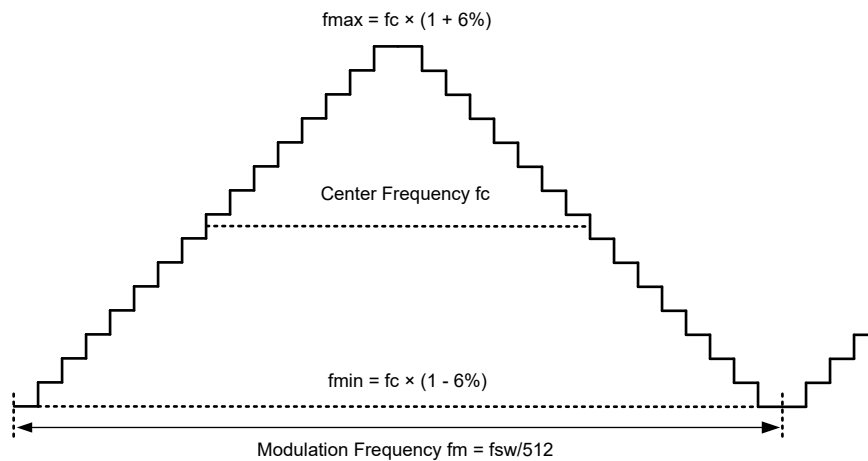

**Figure 6-2. Frequency Spread Spectrum Diagram**

### 6.3.13 Output Overvoltage Protection (OVP)

The TPS54202x incorporates an overvoltage transient protection (OVTP) circuit to minimize output voltage overshoot when recovering from output fault conditions or strong unload transients. The OVP circuit includes an overvoltage comparator to compare the FB pin voltage and internal thresholds. When the FB pin voltage goes above  $108\% \times V_{ref}$ , the high-side MOSFET is forced off. When the FB pin voltage falls below  $104\% \times V_{ref}$ , the high-side MOSFET is enabled again.

### 6.3.14 Thermal Shutdown

The internal thermal-shutdown circuitry forces the device to stop switching if the junction temperature exceeds  $160^{\circ}\text{C}$  typically. When the junction temperature drops below  $150^{\circ}\text{C}$  typically, the internal thermal-hiccup timer begins to count. The device reinitiates the power-up sequence after the built-in thermal-shutdown hiccup time (32768 cycles) is over.

## 6.4 Device Functional Modes

### 6.4.1 Normal Operation

When the input voltage is above the UVLO threshold, the TPS54202x can operate in the normal switching modes. Normal continuous conduction mode (CCM) occurs when inductor peak current is above  $0\text{A}$ . In CCM, the device operates at a fixed frequency.

### **6.4.2 Eco-mode Operation**

The devices are designed to operate in high-efficiency pulse-skipping mode under light load conditions. Pulse skipping initiates when the switch current falls to 0A. During pulse skipping, the low-side FET turns off when the switch current falls to 0A. The switching node (the SW pin) waveform takes on the characteristics of discontinuous conduction mode (DCM) operation and the apparent switching frequency decreases. As the output current decreases, the perceived time between switching pulses increases.

## 7 Application and Implementation

### Note

Information in the following applications sections is not part of the TI component specification, and TI does not warrant its accuracy or completeness. TI's customers are responsible for determining suitability of components for their purposes, as well as validating and testing their design implementation to confirm system functionality.

### 7.1 Application Information

The TPS542021 device is typically used as a step-down converter, which converts an input voltage from 5V to 30V to fixed output voltage 5V.

### 7.2 Typical Application

#### 7.2.1 TPS542021 5V to 30V Input, 5V Output Converter

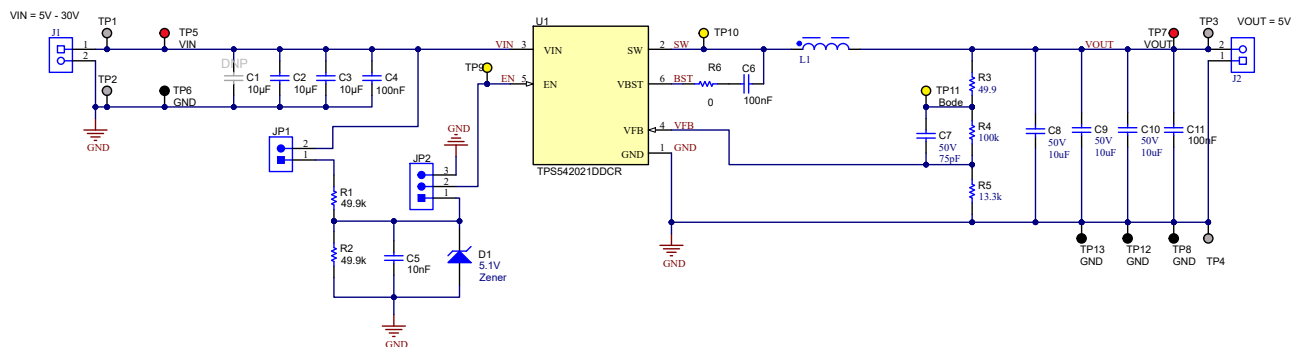

Figure 7-1. 5V, 2A Reference Design

#### 7.2.2 Design Requirements

For this design example, use the parameters in the following table.

Table 7-1. Design Parameters

PARAMETER	VALUE
Input voltage range	5V to 30V
Output voltage	5V
Output current	2A
Transient response, 2A load step	$\Delta V_{OUT} = \pm 5\%$
Output voltage ripple	10mVpp
Switching frequency	500kHz

### 7.2.3 Detailed Design Procedure

#### 7.2.3.1 Input Capacitor Selection

The device requires an input decoupling capacitor, and a bulk capacitor is needed depending on the application. TI recommends a ceramic capacitor over 10µF for the decoupling capacitor. An additional 0.1µF capacitor (C4) from VIN to GND is optional to provide additional high frequency filtering. The capacitor voltage rating must be greater than the maximum input voltage.

Use the following equation to calculate the input ripple voltage ( $\Delta V_{IN}$ ).

$$\Delta V_{IN} = \frac{I_{OUT(MAX)} \times 0.25}{C_{BULK} \times f_{SW}} + I_{OUT(MAX)} \times ESR_{MAX} \quad (4)$$

where:

- $C_{BULK}$  is the bulk capacitor value
- $f_{SW}$  is the switching frequency
- $I_{OUT(MAX)}$  is the maximum loading current
- $ESR_{MAX}$  is maximum series resistance of the bulk capacitor

The maximum RMS (root mean square) ripple current must also be checked. For worst case conditions, use [Equation 5](#) to calculate  $I_{CIN(RMS)}$ .

$$I_{CIN(RMS)} = \frac{I_{OUT(MAX)}}{2} \quad (5)$$

The actual input-voltage ripple is greatly affected by parasitic associated with the layout and the output impedance of the voltage source. *Design Requirements* shows the actual input voltage ripple for this circuit, which is larger than the calculated value. The maximum voltage across the input capacitors is  $V_{IN(MAX)} + \Delta V_{IN}/2$ . The selected bypass capacitor is rated for 50V and the ripple current capacity is greater than 2A. Both values provide ample margin. The maximum ratings for voltage and current must not be exceeded under any circumstance.

#### 7.2.3.2 Bootstrap Capacitor Selection

A 0.1µF ceramic capacitor must be connected between the BOOT to SW pin for proper operation. TI recommends to use a ceramic capacitor.

#### 7.2.3.3 Output Voltage Setpoint

The output voltage of the TPS542021 device is externally adjustable using a resistor divider network. The divider network is comprised of R4 and R5. Use the following equations to calculate the relationship of the output voltage to the resistor divider.

$$R_5 = \frac{R_4 \times V_{ref}}{V_{OUT} - V_{ref}} \quad (6)$$

$$V_{OUT} = V_{ref} \times \left( \frac{R_4}{R_5} + 1 \right) \quad (7)$$

Select a value of R4 to be approximately 100kΩ. Slightly increasing or decreasing R5 can result in closer output voltage matching when using standard value resistors. In this design, R4 = 100kΩ and R5 = 13.3kΩ, which results in a 5V output voltage. The 49.9Ω resistor, R3, is provided as a convenient location to break the control loop for stability testing.

#### 7.2.3.4 Undervoltage Lockout Setpoint

The undervoltage lockout (UVLO) setpoint can be adjusted using the external-voltage divider network of R1 and R2. R1 is connected between the VIN and EN pins of the TPS542021 device. R2 is connected between the EN and GND pins. The UVLO has two thresholds, one for power up when the input voltage is rising and one

for power down or brown outs when the input voltage is falling. Use [Equation 1](#) and [Equation 2](#) to calculate the values for the upper and lower resistor values of R1 and R2.

### 7.2.3.5 Output Filter Components

Two components must be selected for the output filter, the output inductor ( $L_O$ ) and  $C_O$ .

#### 7.2.3.5.1 Inductor Selection

Use the following equation to calculate the minimum value of the output inductor ( $L_{MIN}$ ).

$$L_{MIN} = \frac{V_{OUT} \times [V_{IN(MAX)} - V_{OUT}]}{V_{IN(MAX)} \times K_{IND} \times I_{OUT} \times f_{SW}} \quad (8)$$

Where:

$K_{IND}$  is a coefficient that represents the amount of inductor ripple current relative to the maximum output current.

In general, the value of  $K_{IND}$  is at the discretion of the designer; however, the following guidelines can be used. For designs using low-ESR output capacitors, such as ceramics, a value as high as  $K_{IND} = 0.3$  can be used.

For this design example, use  $K_{IND} = 0.3$ . The minimum inductor value is calculated as 13.7  $\mu$ H. For this design, a close standard value of 15  $\mu$ H is selected for  $L_{MIN}$ .

For the output filter inductor, the RMS current and saturation current ratings must not be exceeded. Use the following equation to calculate the RMS inductor current ( $I_{L(RMS)}$ ).

$$I_{L(MAX)} = \sqrt{I_{OUT(MAX)}^2 + \frac{1}{12} \times \left[ \frac{V_{OUT} \times (V_{IN(MAX)} - V_{OUT})}{V_{IN(MAX)} \times L_O \times f_{SW} \times 0.8} \right]^2} \quad (9)$$

Use the following equation to calculate the peak inductor current ( $I_{L(PK)}$ ).

$$I_{L(PK)} = I_{OUT(MAX)} + \frac{V_{OUT} \times [V_{IN(MAX)} - V_{OUT}]}{V_{IN(MAX)} \times L_O \times f_{SW} \times 1.6} \quad (10)$$

Smaller or larger inductor values can be used depending on the amount of ripple current the designer wants to allow so long as the other design requirements are met. Larger value inductors have lower AC current and result in lower output voltage ripple. Smaller inductor values increase AC current and output voltage ripple.

#### 7.2.3.5.2 Output Capacitor Selection

Consider three primary factors when selecting the value of the output capacitor. The output capacitor determines the modulator pole, the output voltage ripple, and how the regulator responds to a large change in load current. The output capacitance must be selected based on the more stringent of these three criteria.

The desired response to a large change in the load current is the first criterion. The output capacitor must supply the load with current when the regulator cannot. This situation occurs if the desired hold-up times are present for the regulator. In this case, the output capacitor must hold the output voltage above a certain level for a specified amount of time after the input power is removed. The regulator is also temporarily unable to supply sufficient output current if a large, fast increase occurs affecting the current requirements of the load, such as a transition from no load to full load. The regulator typically requires two or more clock cycles for the control loop to notice the change in load current and output voltage and to adjust the duty cycle to react to the change. The output capacitor must be sized to supply the extra current to the load until the control loop responds to the load change. The output capacitance must be large enough to supply the difference in current for two clock cycles while only allowing a tolerable amount of drop in the output voltage. Use the following equation to calculate the minimum required output capacitance.

$$C_O = \frac{2 \times \Delta I_{OUT}}{f_{SW} \times \Delta V_{OUT}} \quad (11)$$

where:

- $\Delta I_{OUT}$  is the change in output current
- $f_{SW}$  is the switching frequency of the regulator
- $\Delta V_{(OUT)}$  is the allowable change in the output voltage

For this example, the transient load response is specified as a 5% change in the output voltage,  $V_{OUT}$ , for a load step of 1.5A. For this example,  $\Delta I_{OUT} = 1.5A$  and  $\Delta V_{OUT} = 0.05 \times 5 = 0.25V$ . Using these values results in a minimum capacitance of 24 $\mu$ F. This value does not consider the ESR of the output capacitor in the output voltage change. For ceramic capacitors, the ESR is typically small enough to ignore in this calculation.

[Equation 12](#) calculates the minimum output capacitance required to meet the output voltage ripple specification. In this case, the maximum output voltage ripple is 30mV. Under this requirement, [Equation 12](#) yields 4.56 $\mu$ F.

$$C_O = \frac{1}{8 \times f_{SW}} \times \frac{1}{\frac{V_{OUTripplle}}{I_{ripple}}} \quad (12)$$

where:

- $f_{SW}$  is the switching frequency
- $V_{(OUTripplle)}$  is the maximum allowable output voltage ripple
- $I_{(ripple)}$  is the inductor ripple current

Use [Equation 13](#) to calculate the maximum ESR an output capacitor can have to meet the output-voltage ripple specification. [Equation 13](#) indicates the ESR must be less than 54.8m $\Omega$ . In this case, the ESR of the ceramic capacitor is much smaller than 54.8m $\Omega$ .

$$R_{ESR} < \frac{V_{OUTripplle}}{I_{ripple}} \quad (13)$$

The output capacitor can affect the crossover frequency  $f_o$ . Considering to the loop stability and effect of the internal parasitic parameters, choose the crossover frequency less than 40kHz without considering the feed forward capacitor. A simple estimation for the crossover frequency without feed forward capacitor C6 is shown in [Equation 14](#), assuming  $C_{OUT}$  has small ESR.

$$f_o = \frac{3.95}{V_{OUT} \times C_{OUT}} \quad (14)$$

Additional capacitance deratings for aging, temperature, and DC bias must be considered, which increases this minimum value. For this example, two 22 $\mu$ F 25V, X7R ceramic capacitors are used. Capacitors generally have limits to the amount of ripple current the capacitors can handle without failing or producing excess heat. An output capacitor that can support the inductor ripple current must be specified. Some capacitor data sheets specify the RMS value of the maximum ripple current. Use [Equation 15](#) to calculate the RMS ripple current that the output capacitor must support. For this application, [Equation 15](#) yields 79mA for each capacitor.

$$I_{COUT(RMS)} = \frac{1}{\sqrt{12}} \times \left[ \frac{V_{OUT} \times (V_{IN(MAX)} - V_{OUT})}{V_{IN(MAX)} \times L_O \times f_{SW} \times N_C} \right] \quad (15)$$

#### 7.2.3.5.3 Feed-Forward Capacitor

In some cases, a feedforward capacitor can be used across  $R_{FBT}$  to improve the load transient response or improve the loop phase margin. This statement is especially true when values of  $R_{FBT} > 100k\Omega$  are used. Large values of  $R_{FBT}$  in combination with the parasitic capacitance at the FB pin can create a small signal pole that interferes with the loop stability. A  $C_{FF}$  helps mitigate this effect. Use lower values to determine if any advantage is gained by the use of a  $C_{FF}$  capacitor.

The [Optimizing Transient Response of Internally Compensated DC-DC Converters with Feedforward Capacitor application report](#) is helpful when experimenting with a feedforward capacitor.

**Table 7-2. Recommended Component Values**

$V_{OUT}$ (V)	L ( $\mu$ H)	$C_{OUT}$ ( $\mu$ F)	R2 (k $\Omega$ )	R3 (k $\Omega$ )	C6 (pF)
1.8	5.6	66	100	49.9	47
2.5	8.2	44	100	31.6	33
3.3	10	44	100	22.1	56
5	15	44	100	13.3	75
12	22	44	100	5.23	100

### 7.2.4 Application Curves

The following data is tested with  $V_{IN} = 24V$ ,  $V_{OUT} = 5V$ ,  $T_A = 25^\circ C$ , unless otherwise specified.

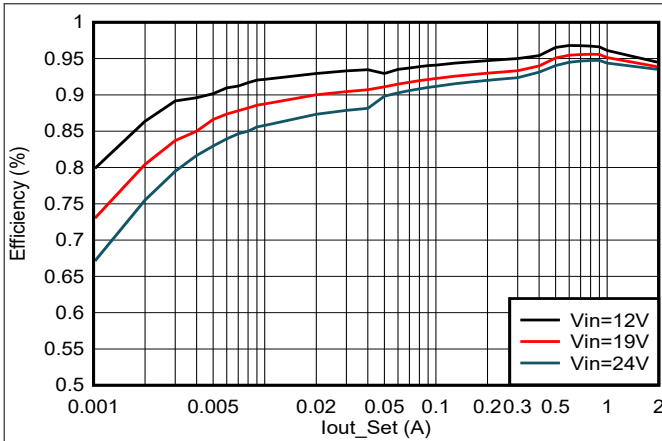

Figure 7-2. TPS542021EVM Efficiency

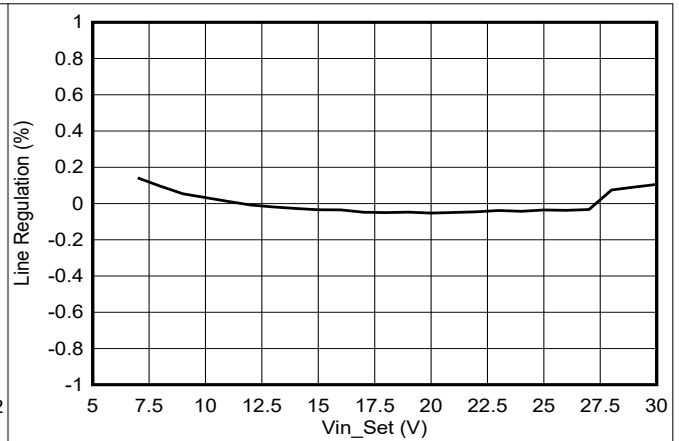

Figure 7-3. TPS542021EVM Line Regulation,  $I_{OUT} = 2A$

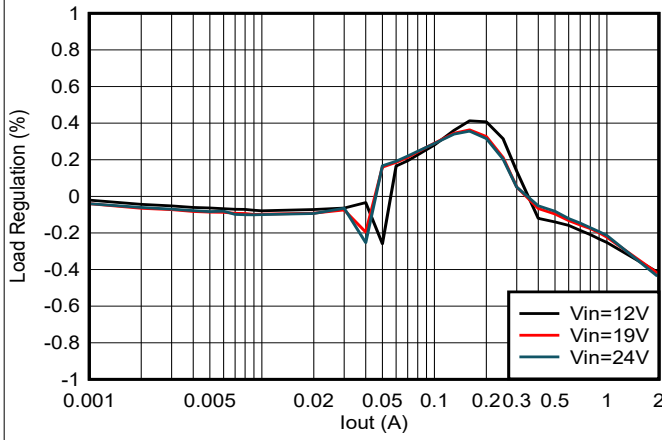

Figure 7-4. TPS542021EVM Load Regulation

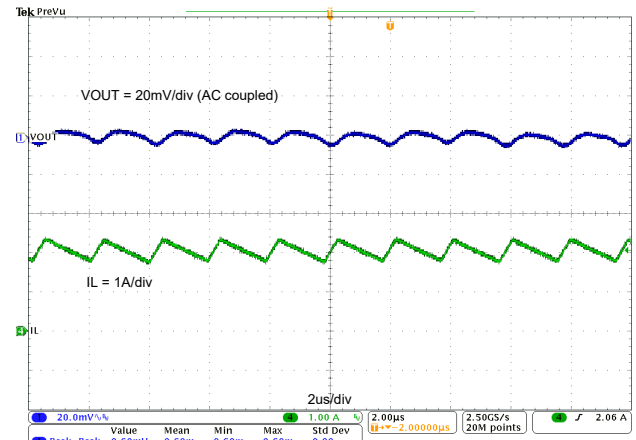

Figure 7-5. TPS542021EVM Output Voltage Ripple,  $I_{OUT} = 2A$

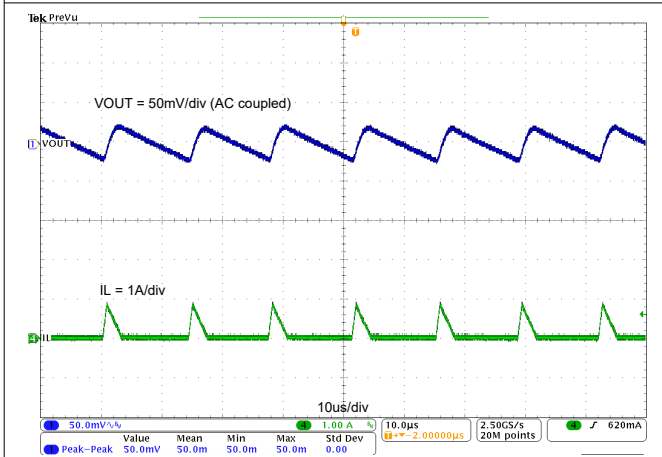

Figure 7-6. TPS542021EVM Output Voltage Ripple,  $I_{OUT} = 0.1A$

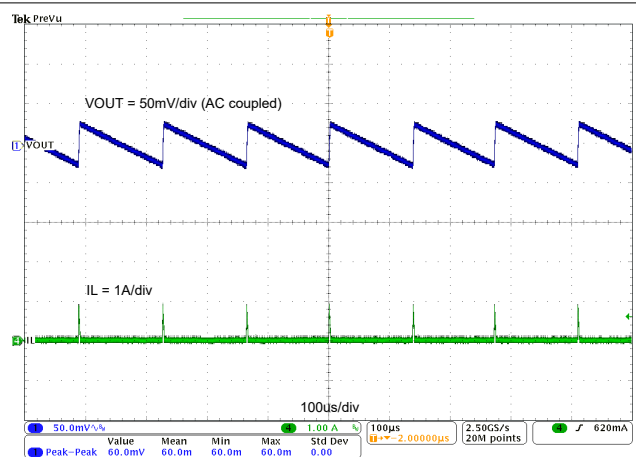

Figure 7-7. TPS542021EVM Output Voltage Ripple,  $I_{OUT} = 0.01A$

**TPS542021, TPS542025**

SLVSI78B – JANUARY 2025 – REVISED DECEMBER 2025

**7.2.4 Application Curves (continued)**

The following data is tested with  $V_{IN} = 24V$ ,  $V_{OUT} = 5V$ ,  $T_A = 25^\circ C$ , unless otherwise specified.

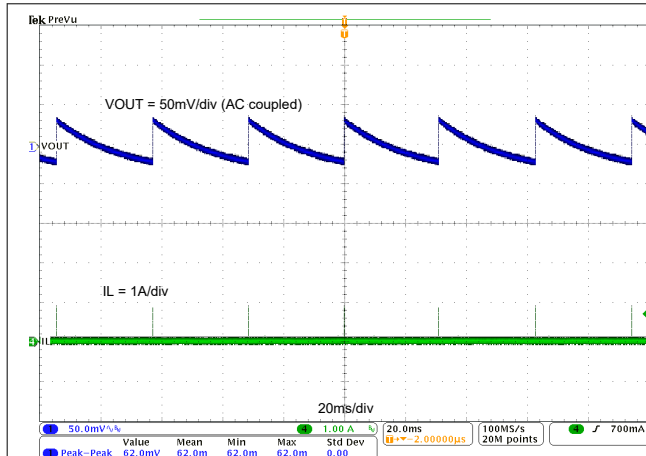

**Figure 7-8. TPS542021EVM Output Voltage Ripple,  $I_{OUT} = 0A$**

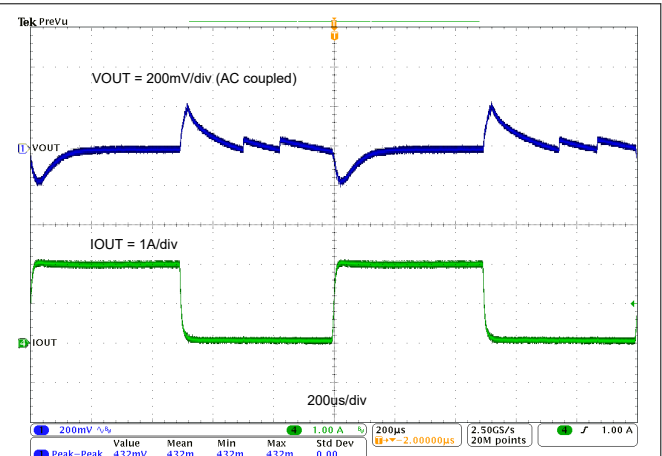

**Figure 7-9. TPS542021EVM Load Transient Response, 0A to 2A Load Step**

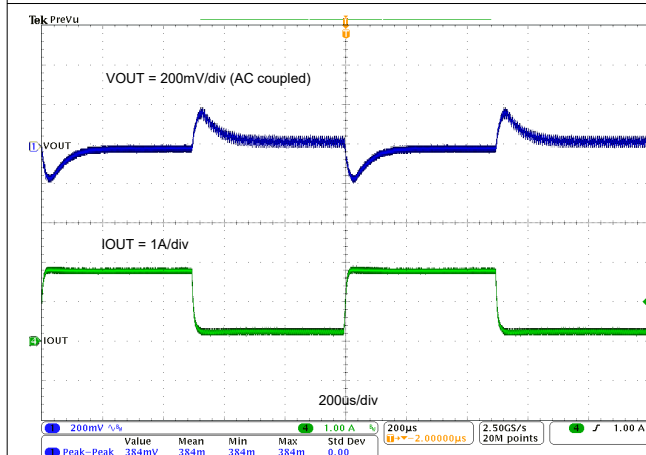

**Figure 7-10. TPS542021EVM Load Transient Response, 0.2A to 1.8A Load Step**

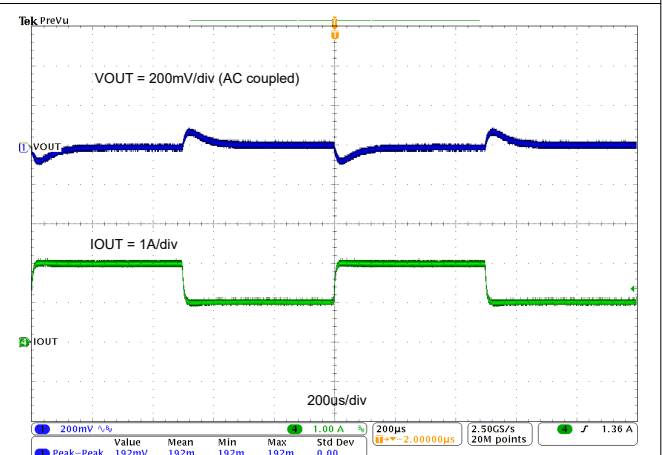

**Figure 7-11. TPS542021EVM Load Transient Response, 1A to 2A Load Step**

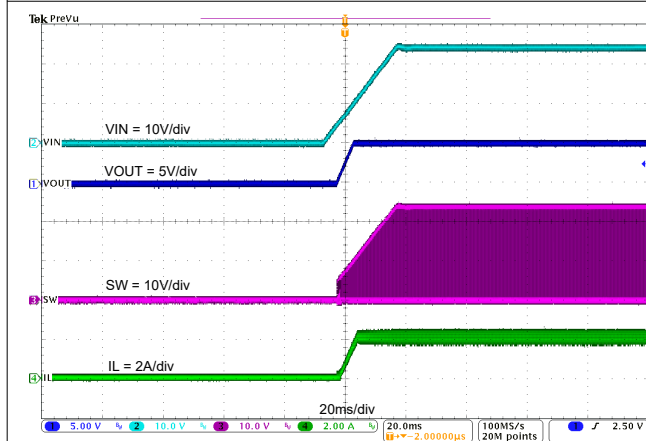

**Figure 7-12. TPS542021EVM Start-Up Relative to  $V_{IN}$**

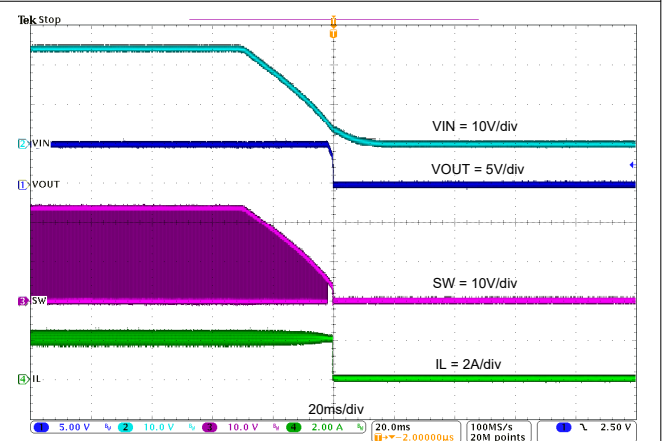

**Figure 7-13. TPS542021EVM Shutdown Relative to  $V_{IN}$**

## 7.3 Power Supply Recommendations

The devices are designed to operate from an input voltage supply range between 4.5V and 30V. This input supply must be well regulated. If the input supply is located more than a few inches from the device or converter, additional bulk capacitance can be required in addition to the ceramic bypass capacitors. An electrolytic capacitor with a value of 47 $\mu$ F is a typical choice.

## 7.4 Layout

### 7.4.1 Layout Guidelines

- Make VIN and GND traces as wide as possible to reduce trace impedance. The wide areas are also of advantage from the view point of heat dissipation.
- Place the input capacitor and output capacitor as close to the device as possible to minimize trace impedance.
- Provide sufficient vias for the input capacitor and output capacitor.
- Keep the SW trace as physically short and wide as practical to minimize radiated emissions.
- Do not allow switching current to flow under the device.
- Connect a separate VOUT path to the upper feedback resistor.
- Make a Kelvin connection to the GND pin for the feedback path.
- Place the voltage feedback loop away from the high-voltage switching trace, and preferably have ground shield.
- Make the trace of the VFB node as small as possible to avoid noise coupling.
- Make the GND trace between the output capacitor and the GND pin as wide as possible to minimize the trace impedance.

### 7.4.2 Layout Example

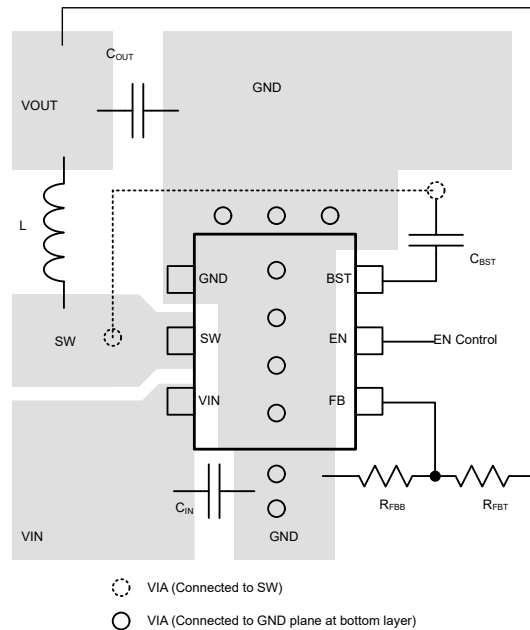

**Figure 7-14. Board Layout**

## 8 Device and Documentation Support

### 8.1 Device Support

#### 8.1.1 Third-Party Products Disclaimer

TI'S PUBLICATION OF INFORMATION REGARDING THIRD-PARTY PRODUCTS OR SERVICES DOES NOT CONSTITUTE AN ENDORSEMENT REGARDING THE SUITABILITY OF SUCH PRODUCTS OR SERVICES OR A WARRANTY, REPRESENTATION OR ENDORSEMENT OF SUCH PRODUCTS OR SERVICES, EITHER ALONE OR IN COMBINATION WITH ANY TI PRODUCT OR SERVICE.

### 8.2 Documentation Support

#### 8.2.1 Related Documentation

For related documentation, see the following:

Texas Instruments, [Optimizing Transient Response of Internally Compensated DC-DC Converters with Feedforward Capacitor application report](#)

### 8.3 Receiving Notification of Documentation Updates

To receive notification of documentation updates, navigate to the device product folder on [ti.com](#). Click on *Notifications* to register and receive a weekly digest of any product information that has changed. For change details, review the revision history included in any revised document.

### 8.4 Support Resources

TI E2E™ [support forums](#) are an engineer's go-to source for fast, verified answers and design help — straight from the experts. Search existing answers or ask your own question to get the quick design help you need.

Linked content is provided "AS IS" by the respective contributors. They do not constitute TI specifications and do not necessarily reflect TI's views; see TI's [Terms of Use](#).

### 8.5 Trademarks

TI E2E™ is a trademark of Texas Instruments.

All trademarks are the property of their respective owners.

### 8.6 Electrostatic Discharge Caution



This integrated circuit can be damaged by ESD. Texas Instruments recommends that all integrated circuits be handled with appropriate precautions. Failure to observe proper handling and installation procedures can cause damage.

ESD damage can range from subtle performance degradation to complete device failure. Precision integrated circuits may be more susceptible to damage because very small parametric changes could cause the device not to meet its published specifications.

### 8.7 Glossary

[TI Glossary](#) This glossary lists and explains terms, acronyms, and definitions.

## 9 Revision History

NOTE: Page numbers for previous revisions may differ from page numbers in the current version.

<b>Changes from Revision A (April 2025) to Revision B (December 2025)</b>	<b>Page</b>
• Changed document status from Advance Information to Production Data.....	1
• Changed $I_{SD(VIN)}$ typ value from 2 $\mu$ A to 3 $\mu$ A in the Electrical Characteristics .....	5
• Added temperature variation for $V_{FB}$ at 25°C in the Electrical Characteristics.....	5
• Added $t_{ON\_MIN}$ specification in the Electrical Characteristics.....	5
• Added OVP thresholds in the Electrical Characteristics.....	5
• Added $f_{FSS}$ value in the Electrical Characteristics.....	5
• Added $f_{SPREAD}$ value in the Electrical Characteristics.....	5

---

<b>Changes from Revision * (January 2025) to Revision A (April 2025)</b>	<b>Page</b>
• Added SOT-563 package information.....	1
• Added SOT-563 information.....	1
• Added SOT-563 package information.....	3

---

## 10 Mechanical, Packaging, and Orderable Information

The following pages include mechanical, packaging, and orderable information. This information is the most current data available for the designated devices. This data is subject to change without notice and revision of this document. For browser-based versions of this data sheet, refer to the left-hand navigation.

**PACKAGING INFORMATION**

Orderable part number	Status (1)	Material type (2)	Package   Pins	Package qty   Carrier	RoHS (3)	Lead finish/ Ball material (4)	MSL rating/ Peak reflow (5)	Op temp (°C)	Part marking (6)
<a href="#">PTPS542021DDCR</a>	Active	Preproduction	SOT-23-THIN (DDC)   6	3000   LARGE T&R	-	Call TI	Call TI	-40 to 150	
PTPS542021DDCR.A	Active	Preproduction	SOT-23-THIN (DDC)   6	3000   LARGE T&R	-	Call TI	Call TI	-40 to 150	
<a href="#">PTPS542021DRLR</a>	Active	Preproduction	SOT-5X3 (DRL)   6	4000   LARGE T&R	-	Call TI	Call TI	-40 to 150	
<a href="#">TPS542021DDCR</a>	Active	Production	SOT-23-THIN (DDC)   6	3000   LARGE T&R	Yes	SN	Level-1-260C-UNLIM	-40 to 150	021C
<a href="#">TPS542025DDCR</a>	Active	Production	SOT-23-THIN (DDC)   6	3000   LARGE T&R	Yes	SN	Level-1-260C-UNLIM	-40 to 150	025C

(1) **Status:** For more details on status, see our [product life cycle](#).

(2) **Material type:** When designated, preproduction parts are prototypes/experimental devices, and are not yet approved or released for full production. Testing and final process, including without limitation quality assurance, reliability performance testing, and/or process qualification, may not yet be complete, and this item is subject to further changes or possible discontinuation. If available for ordering, purchases will be subject to an additional waiver at checkout, and are intended for early internal evaluation purposes only. These items are sold without warranties of any kind.

(3) **RoHS values:** Yes, No, RoHS Exempt. See the [TI RoHS Statement](#) for additional information and value definition.

(4) **Lead finish/Ball material:** Parts may have multiple material finish options. Finish options are separated by a vertical ruled line. Lead finish/Ball material values may wrap to two lines if the finish value exceeds the maximum column width.

(5) **MSL rating/Peak reflow:** The moisture sensitivity level ratings and peak solder (reflow) temperatures. In the event that a part has multiple moisture sensitivity ratings, only the lowest level per JEDEC standards is shown. Refer to the shipping label for the actual reflow temperature that will be used to mount the part to the printed circuit board.

(6) **Part marking:** There may be an additional marking, which relates to the logo, the lot trace code information, or the environmental category of the part.

Multiple part markings will be inside parentheses. Only one part marking contained in parentheses and separated by a "~" will appear on a part. If a line is indented then it is a continuation of the previous line and the two combined represent the entire part marking for that device.

**Important Information and Disclaimer:** The information provided on this page represents TI's knowledge and belief as of the date that it is provided. TI bases its knowledge and belief on information provided by third parties, and makes no representation or warranty as to the accuracy of such information. Efforts are underway to better integrate information from third parties. TI has taken and continues to take reasonable steps to provide representative and accurate information but may not have conducted destructive testing or chemical analysis on incoming materials and chemicals. TI and TI suppliers consider certain information to be proprietary, and thus CAS numbers and other limited information may not be available for release.

In no event shall TI's liability arising out of such information exceed the total purchase price of the TI part(s) at issue in this document sold by TI to Customer on an annual basis.

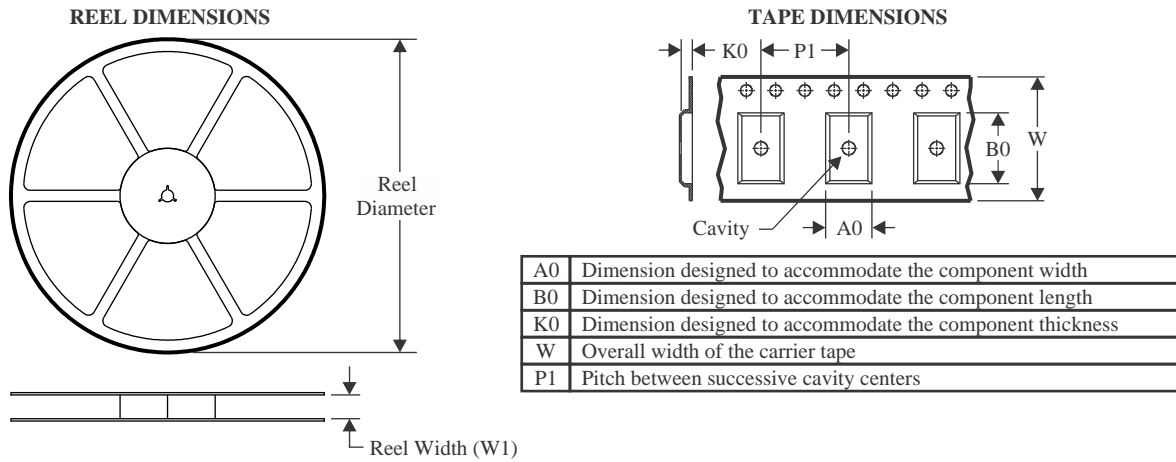
**TAPE AND REEL INFORMATION**

**QUADRANT ASSIGNMENTS FOR PIN 1 ORIENTATION IN TAPE**

\*All dimensions are nominal

Device	Package Type	Package Drawing	Pins	SPQ	Reel Diameter (mm)	Reel Width W1 (mm)	A0 (mm)	B0 (mm)	K0 (mm)	P1 (mm)	W (mm)	Pin1 Quadrant
TPS542021DDCR	SOT-23-THIN	DDC	6	3000	180.0	8.4	3.2	3.2	1.4	4.0	8.0	Q3
TPS542025DDCR	SOT-23-THIN	DDC	6	3000	180.0	8.4	3.2	3.2	1.4	4.0	8.0	Q3

**TAPE AND REEL BOX DIMENSIONS**

\*All dimensions are nominal

Device	Package Type	Package Drawing	Pins	SPQ	Length (mm)	Width (mm)	Height (mm)
TPS542021DDCR	SOT-23-THIN	DDC	6	3000	210.0	185.0	35.0
TPS542025DDCR	SOT-23-THIN	DDC	6	3000	210.0	185.0	35.0



# EXAMPLE BOARD LAYOUT

DDC0006A

SOT-23 - 1.1 max height

SMALL OUTLINE TRANSISTOR

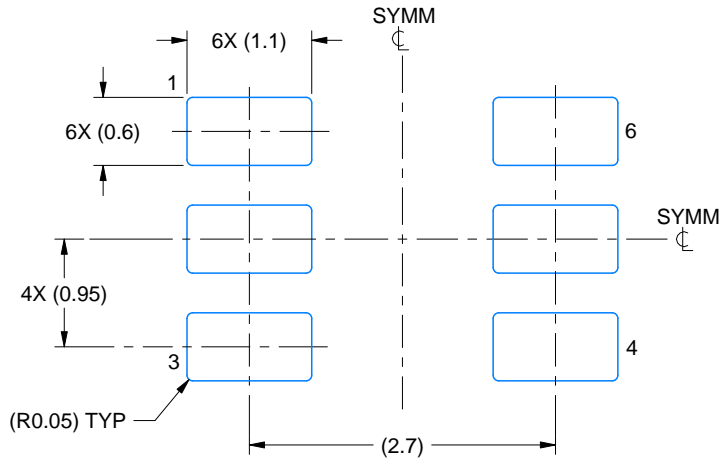

LAND PATTERN EXAMPLE  
EXPLODED METAL SHOWN  
SCALE:15X

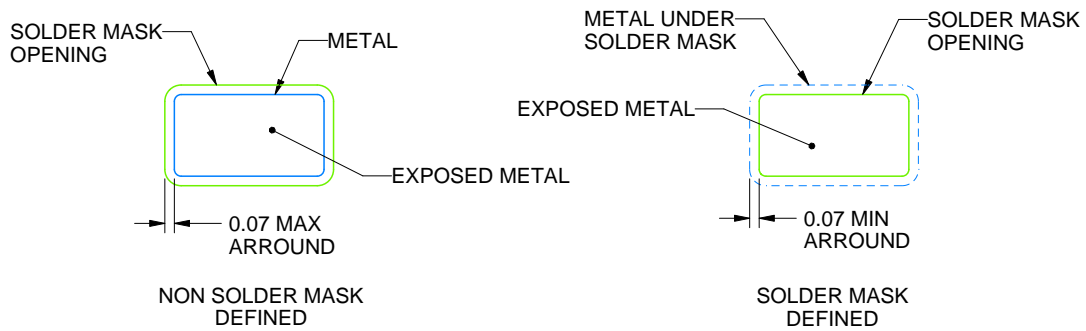

SOLDEMASK DETAILS

4214841/E 08/2024

NOTES: (continued)

- 4. Publication IPC-7351 may have alternate designs.
- 5. Solder mask tolerances between and around signal pads can vary based on board fabrication site.

# EXAMPLE STENCIL DESIGN

DDC0006A

SOT-23 - 1.1 max height

SMALL OUTLINE TRANSISTOR

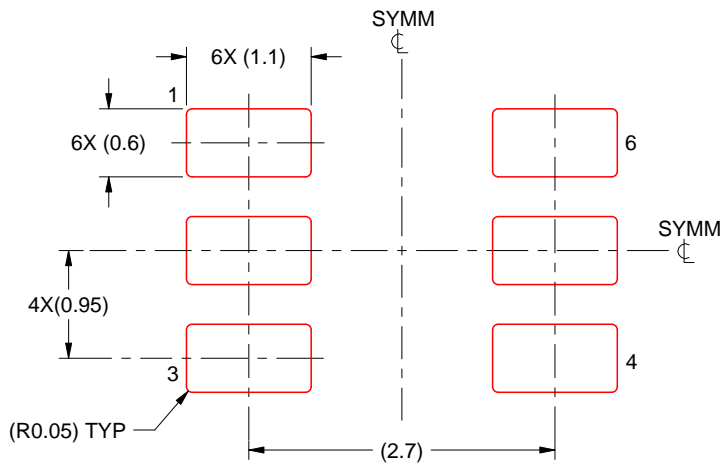

SOLDER PASTE EXAMPLE  
BASED ON 0.125 THICK STENCIL  
SCALE:15X

4214841/E 08/2024

NOTES: (continued)

6. Laser cutting apertures with trapezoidal walls and rounded corners may offer better paste release. IPC-7525 may have alternate design recommendations.
7. Board assembly site may have different recommendations for stencil design.

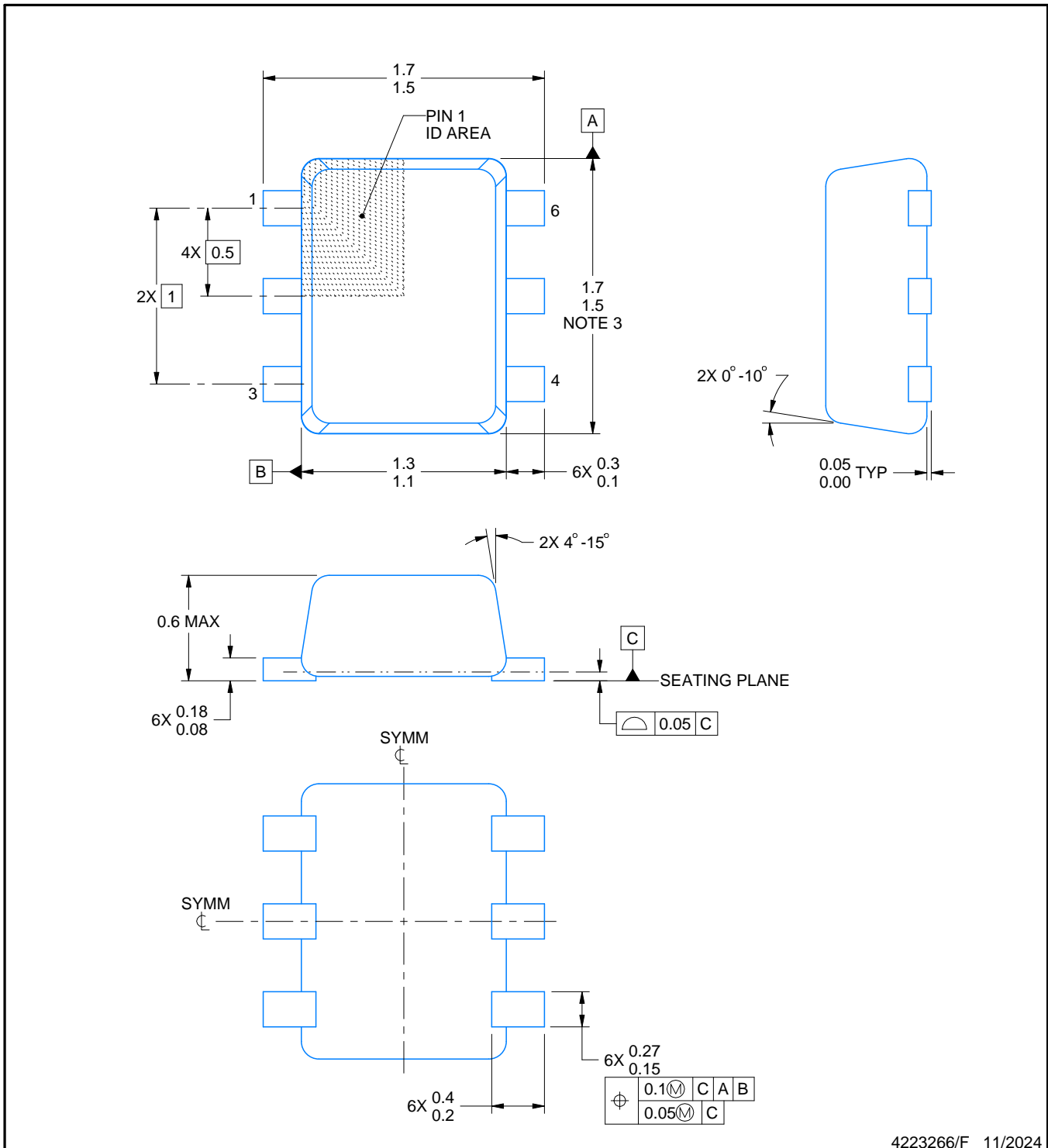

4223266/F 11/2024

NOTES:

1. All linear dimensions are in millimeters. Any dimensions in parenthesis are for reference only. Dimensioning and tolerancing per ASME Y14.5M.
2. This drawing is subject to change without notice.
3. This dimension does not include mold flash, protrusions, or gate burrs. Mold flash, protrusions, or gate burrs shall not exceed 0.15 mm per side.
4. Reference JEDEC registration MO-293 Variation UAAD

# EXAMPLE BOARD LAYOUT

DRL0006A

SOT - 0.6 mm max height

PLASTIC SMALL OUTLINE

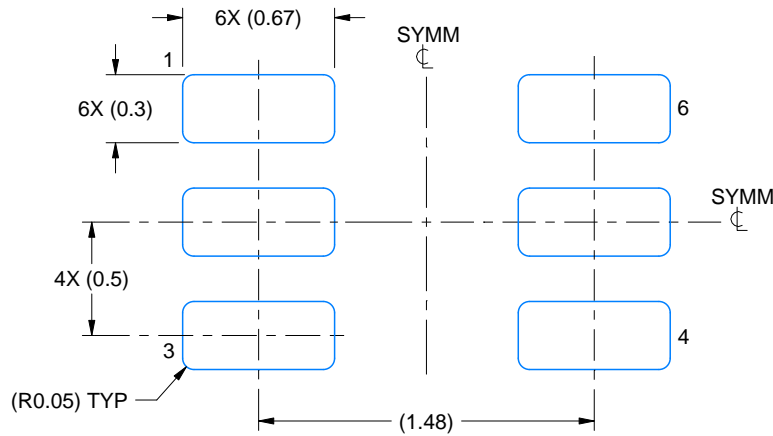

LAND PATTERN EXAMPLE  
SCALE:30X

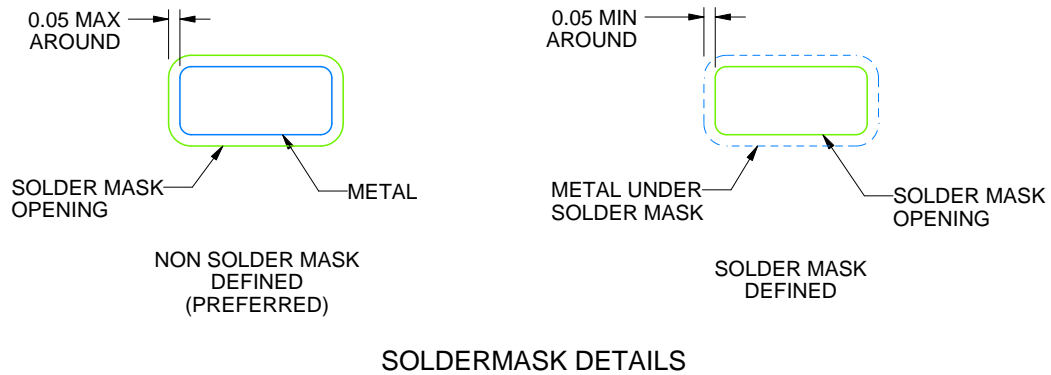

SOLDERMASK DETAILS

4223266/F 11/2024

NOTES: (continued)

5. Publication IPC-7351 may have alternate designs.
6. Solder mask tolerances between and around signal pads can vary based on board fabrication site.
7. Land pattern design aligns to IPC-610, Bottom Termination Component (BTC) solder joint inspection criteria.

# EXAMPLE STENCIL DESIGN

DRL0006A

SOT - 0.6 mm max height

PLASTIC SMALL OUTLINE

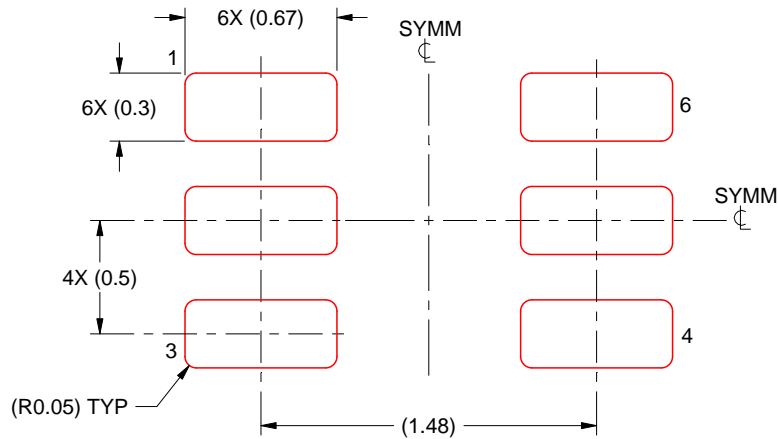

SOLDER PASTE EXAMPLE  
BASED ON 0.1 mm THICK STENCIL  
SCALE:30X

4223266/F 11/2024

NOTES: (continued)

8. Laser cutting apertures with trapezoidal walls and rounded corners may offer better paste release. IPC-7525 may have alternate design recommendations.
9. Board assembly site may have different recommendations for stencil design.

## IMPORTANT NOTICE AND DISCLAIMER

TI PROVIDES TECHNICAL AND RELIABILITY DATA (INCLUDING DATASHEETS), DESIGN RESOURCES (INCLUDING REFERENCE DESIGNS), APPLICATION OR OTHER DESIGN ADVICE, WEB TOOLS, SAFETY INFORMATION, AND OTHER RESOURCES "AS IS" AND WITH ALL FAULTS, AND DISCLAIMS ALL WARRANTIES, EXPRESS AND IMPLIED, INCLUDING WITHOUT LIMITATION ANY IMPLIED WARRANTIES OF MERCHANTABILITY, FITNESS FOR A PARTICULAR PURPOSE OR NON-INFRINGEMENT OF THIRD PARTY INTELLECTUAL PROPERTY RIGHTS.

These resources are intended for skilled developers designing with TI products. You are solely responsible for (1) selecting the appropriate TI products for your application, (2) designing, validating and testing your application, and (3) ensuring your application meets applicable standards, and any other safety, security, regulatory or other requirements.

These resources are subject to change without notice. TI grants you permission to use these resources only for development of an application that uses the TI products described in the resource. Other reproduction and display of these resources is prohibited. No license is granted to any other TI intellectual property right or to any third party intellectual property right. TI disclaims responsibility for, and you fully indemnify TI and its representatives against any claims, damages, costs, losses, and liabilities arising out of your use of these resources.

TI's products are provided subject to [TI's Terms of Sale](#), [TI's General Quality Guidelines](#), or other applicable terms available either on [ti.com](http://ti.com) or provided in conjunction with such TI products. TI's provision of these resources does not expand or otherwise alter TI's applicable warranties or warranty disclaimers for TI products. Unless TI explicitly designates a product as custom or customer-specified, TI products are standard, catalog, general purpose devices.

TI objects to and rejects any additional or different terms you may propose.

Copyright © 2026, Texas Instruments Incorporated

Last updated 10/2025