

TVS1401 14-V Bidirectional Flat-Clamp Surge Protection Device

1 Features

- **Functional safety-capable**
 - [Documentation available to aid functional safety system design](#)
- Protection against 1 kV, 42 Ω IEC 61000-4-5 surge test for industrial signal lines
- Bidirectional polarity enables protection against bipolar signaling or miswiring conditions
- Clamping voltage of 20.5 V at 30 A of 8/20 μs surge current
- Standoff voltage: ±14 V
- Small 3-mm × 3-mm SON footprint
- Survives over 5,000 repetitive strikes of 30 A 8/20 μs surge current at 125°C
- Robust surge protection
 - IEC61000-4-5 (8/20 μs): 30 A
 - IEC61643-321 (10/1000 μs): 6 A
- Low leakage current
 - 1.1 nA typical at 27°C
 - 260 nA maximum at 85°C
- Low capacitance: 68 pF
- Integrated Level 4 IEC 61000-4-2 ESD protection

2 Applications

- Industrial sensor I/O
- Solid state drives
- Motor drives
- 12 V power lines
- Appliances
- Medical equipment
- Electrical grid protection and control

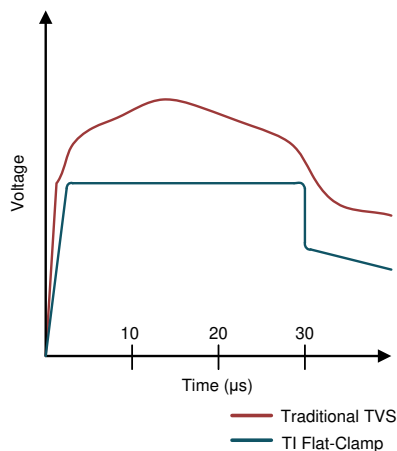

Voltage Clamp Response to 8/20-μs Surge Event

3 Description

The TVS1401 device shunts up to 30 A of IEC 61000-4-5 fault current to protect systems from high power transients or lightning strikes. The device survives the common industrial signal line EMC requirement of 1 kV IEC 61000-4-5 open circuit voltage coupled through a 42-Ω impedance. The TVS1401 uses a feedback mechanism to ensure precise flat clamping during a fault, keeping system exposure lower than traditional TVS diodes. The tight voltage regulation allows designers to confidently select system components with a lower voltage tolerance, lowering system costs and complexity without sacrificing robustness. The TVS1401 has a ±14 V operating range to enable operation in systems that require protection against reverse wiring conditions.

In addition, the TVS1401 is available in a small SON footprint which is designed for space constrained applications, offering a significant size reduction compared to standard SMA and SMB packages. Low device leakage and capacitance ensure a minimal effect on the protected line. To ensure robust protection over the lifetime of the product, TI tests the TVS1401 against 5,000 repetitive surge strikes at 125°C with no shift in device performance.

Device Information⁽¹⁾

PART NUMBER	PACKAGE	BODY SIZE (NOM)
TVS1401	SON (8)	3.00 mm × 3.00 mm

(1) For all available packages, see the orderable addendum at the end of the data sheet.

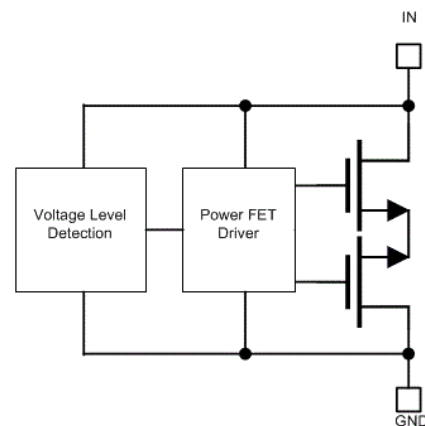

Functional Block Diagram



Table of Contents

1 Features	1	9.3 Feature Description.....	8
2 Applications	1	9.4 Device Functional Modes.....	8
3 Description	1	10 Application and Implementation	10
4 Revision History	2	10.1 Application Information.....	10
5 Description (continued)	3	10.2 Typical Application.....	10
6 Device Comparison Table	3	11 Power Supply Recommendations	11
7 Pin Configuration and Functions	4	12 Layout	12
8 Specifications	5	12.1 Layout Guidelines.....	12
8.1 Absolute Maximum Ratings.....	5	12.2 Layout Example.....	12
8.2 ESD Ratings - JEDEC.....	5	13 Device and Documentation Support	13
8.3 ESD Ratings - IEC.....	5	13.1 Documentation Support.....	13
8.4 Recommended Operating Conditions.....	5	13.2 Receiving Notification of Documentation Updates..	13
8.5 Thermal Information.....	5	13.3 Support Resources.....	13
8.6 Electrical Characteristics.....	6	13.4 Trademarks.....	13
8.7 Typical Characteristics.....	7	13.5 Electrostatic Discharge Caution.....	13
9 Detailed Description	8	13.6 Glossary.....	13
9.1 Overview.....	8	14 Mechanical, Packaging, and Orderable Information	13
9.2 Functional Block Diagram.....	8		

4 Revision History

NOTE: Page numbers for previous revisions may differ from page numbers in the current version.

Changes from Revision A (December 2018) to Revision B (November 2021)	Page
• Updated the numbering format for tables, figures, and cross-references throughout the document.....	1
• Updated the <i>Features</i> section to include Functional Safety-Capable text.....	1

Changes from Revision * (September 2018) to Revision A (December 2018)	Page
• Changed from Advance Information to Production Data	1

5 Description (continued)

The TVS1401 is part of TI's Flat-Clamp family of surge devices. For a deeper look at the Flat-Clamp family, refer to [Flat-Clamp Surge Protection Technology for Efficient System Protection](#) white paper.

6 Device Comparison Table

DEVICE	V_{rwm}	V_{clamp} at I_{pp}	I_{pp} (8/20 μ s)	Leakage @ V_{rwm}	POLARITY	Package
TVS0500	5	9.2 V	43 A	0.07 nA	Unidirectional	DRV (SON-6)
TVS0701	7	11 V	30 A	0.25 nA	Bidirectional	DRB (SON-8)
TVS1400	14	18.6 V	43 A	2 nA	Unidirectional	DRV (SON-6)
TVS1401	14	20.5 V	30 A	1.1 nA	Bidirectional	DRB (SON-8)
TVS1800	18	22.8 V	40 A	0.3 nA	Unidirectional	DRV (SON-6)
TVS1801	18	27.4 V	30 A	0.4 nA	Bidirectional	DRB (SON-8)
TVS2200	22	27.7 V	40 A	3.2 nA	Unidirectional	DRV (SON-6)
TVS2201	22	29.6 V	30 A	2 nA	Bidirectional	DRB (SON-8)
TVS2700	27	32.5 V	40 A	1.7 nA	Unidirectional	DRV (SON-6)
TVS2701	27	34 V	27 A	0.8 nA	Bidirectional	DRB (SON-8)
TVS3300	33	38 V	35 A	19 nA	Unidirectional	DRV (SON-6), YZF (WCSP)
TVS3301	33	40 V	27 A	2.5 nA	Bidirectional	DRB (SON-8)

7 Pin Configuration and Functions

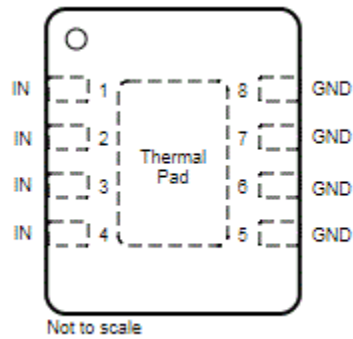

**Figure 7-1. DRB Package
8-Pin SON
Top View**

Pin Functions

PIN		TYPE	DESCRIPTION
NAME	DRB		
FLOAT	Exposed Thermal Pad	NC	Exposed Thermal Pad Must Be Floating
GND	5, 6, 7, 8	GND	Ground
IN	1, 2, 3, 4	IN	Surge Protected Channel

8 Specifications

8.1 Absolute Maximum Ratings

$T_A = 27^\circ\text{C}$ (unless otherwise noted)⁽¹⁾

		MIN	MAX	UNIT
Maximum Surge	IEC 61000-4-5 Current (8/20 μs), $T_A < 125^\circ\text{C}$		± 30	A
	IEC 61000-4-5 Power (8/20 μs)		600	W
	IEC 61643-321 Current (10/1000 μs)		± 6	A
	IEC 61643-321 Power (10/1000 μs)		120	W
EFT	IEC 61000-4-4 EFT Protection		± 80	A
I_{BR}	DC Current		45	mA
T_A	Ambient Operating Temperature	-40	125	$^\circ\text{C}$
T_{stg}	Storage Temperature	-65	125	$^\circ\text{C}$

- (1) Stresses beyond those listed under *Absolute Maximum Rating* may cause permanent damage to the device. These are stress ratings only, which do not imply functional operation of the device at these or any other conditions beyond those indicated under *Recommended Operating Condition*. Exposure to absolute-maximum-rated conditions for extended periods may affect device reliability.

8.2 ESD Ratings - JEDEC

			VALUE	UNIT
$V_{(ESD)}$	Electrostatic discharge	Human body model (HBM), per ANSI/ESDA/JEDEC JS-001, all pins ⁽¹⁾	± 2000	V
		Charged device model (CDM), per JEDEC specification JESD22-C101, all pins ⁽²⁾	± 500	

- (1) JEDEC document JEP155 states that 500-V HBM allows safe manufacturing with a standard ESD control process.
 (2) JEDEC document JEP157 states that 250-V CDM allows safe manufacturing with a standard ESD control process.

8.3 ESD Ratings - IEC

			VALUE	UNIT
$V_{(ESD)}$	Electrostatic discharge	IEC 61000-4-2 contact discharge	± 8	kV
		IEC 61000-4-2 air-gap discharge	± 15	

8.4 Recommended Operating Conditions

over operating free-air temperature range (unless otherwise noted)

		MIN	NOM	MAX	UNIT
V_{RWM}	Reverse Stand-Off Voltage		± 14		V

8.5 Thermal Information

THERMAL METRIC ⁽¹⁾		TVS1401	UNIT
		DRB (SON)	
		8 PINS	
R_{qJA}	Junction-to-ambient thermal resistance	52.0	$^\circ\text{C}/\text{W}$
$R_{qJC(top)}$	Junction-to-case (top) thermal resistance	56.1	$^\circ\text{C}/\text{W}$
R_{qJB}	Junction-to-board thermal resistance	24.9	$^\circ\text{C}/\text{W}$
Y_{JT}	Junction-to-top characterization parameter	2.1	$^\circ\text{C}/\text{W}$
Y_{JB}	Junction-to-board characterization parameter	24.8	$^\circ\text{C}/\text{W}$
$R_{qJC(bot)}$	Junction-to-case (bottom) thermal resistance	9.8	$^\circ\text{C}/\text{W}$

- (1) For more information about traditional and new thermal metrics, see the [Semiconductor and IC Package Thermal Metrics](#) application report.

8.6 Electrical Characteristics

over operating free-air temperature range (unless otherwise noted)

PARAMETER		TEST CONDITIONS	MIN	TYP	MAX	UNIT
I _{LEAK}	Leakage Current	Measured at V _{IN} = ±V _{RWM} , T _A = 27°C		1.1	30	nA
		Measured at V _{IN} = ±V _{RWM} , T _A = 85°C			260	
V _{BR}	Break-down Voltage	I _{IN} = ±1mA	17.1	17.6		V
V _{CLAMP}	Clamp Voltage	±I _{pp} IEC 61000-4-5 Surge (8/20 μs), V _{IN} = 0 V before surge, T _A = 27°C		20.5	22.2	V
		±I _{pp} IEC 61000-4-5 Surge (8/20 μs), V _{IN} = ±V _{RWM} before surge, T _A = 125°C			23.55	
R _{DYN}	8/20 μs surge dynamic resistance	Calculated from V _{CLAMP} at .5*I _{pp} and I _{pp} surge current, T _A = 25°C		70		mΩ
C _{IN}	Input pin capacitance	V _{IN} = V _{RWM} , f = 1 MHz, 30 mV _{pp} , IO to GND		68		pF
SR	Maximum Slew Rate	0-±V _{RWM} rising edge, sweep rise time and measure slew rate when I _{PEAK} = 1 mA, T _A = 27°C		2.5		V/μs
		0-±V _{RWM} rising edge, sweep rise time and measure slew rate when I _{PEAK} = 1 mA, T _A = 85°C		1		

8.7 Typical Characteristics

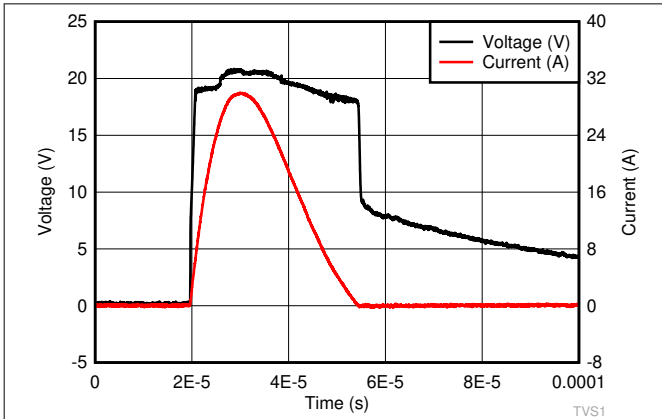

Figure 8-1. 8/20 μ s Surge Response at 30 A

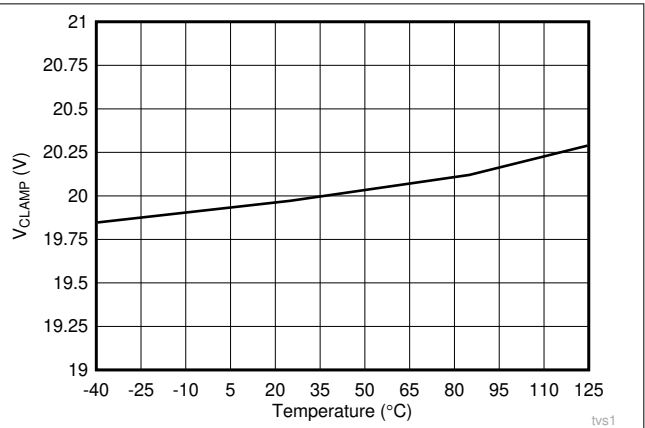
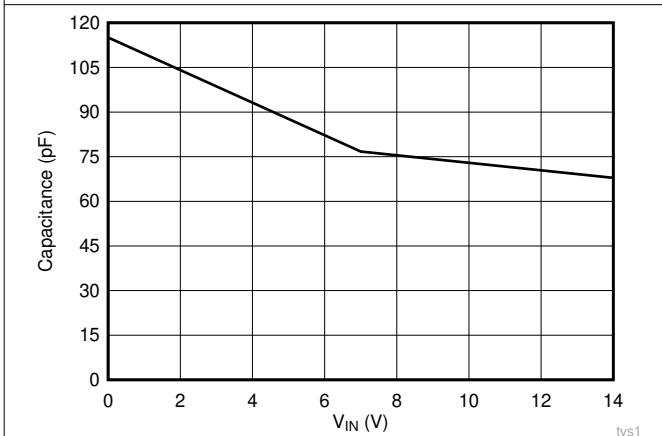

Figure 8-2. 8/20 μ s Surge Clamping Response at 30 A



f = 1 MHz, 30 mVpp, IO to GND

Figure 8-3. Capacitance vs Voltage Bias

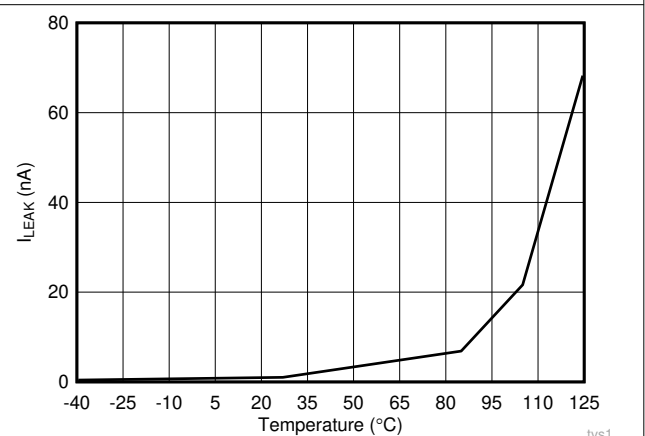

Figure 8-4. Leakage Current vs Temperature at ± 14 V

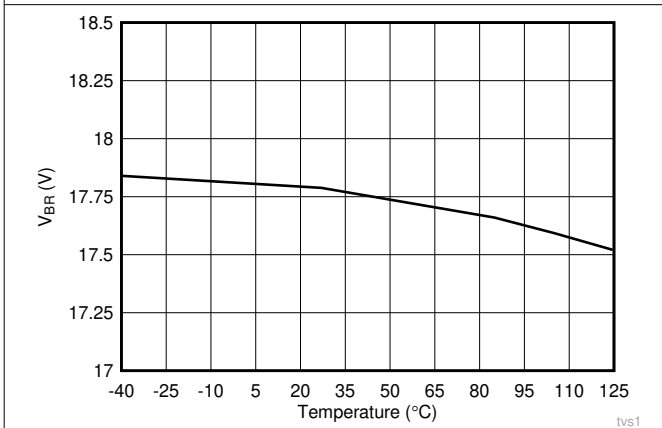

Figure 8-5. Breakdown Voltage (1 mA) vs Temperature

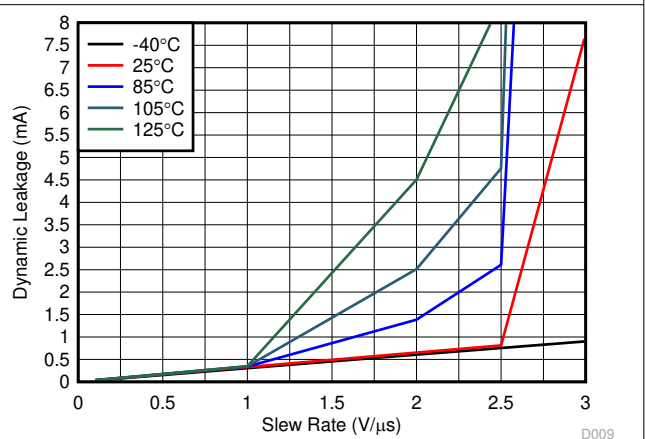

Figure 8-6. Dynamic Leakage vs Signal Slew Rate across Temperature

9 Detailed Description

9.1 Overview

The TVS1401 is a bidirectional precision clamp with two integrated FETs driven by a feedback loop to tightly regulate the input voltage during an overvoltage event. This feedback loop leads to a very low dynamic resistance, giving a flat clamping voltage during transient overvoltage events like a surge.

9.2 Functional Block Diagram

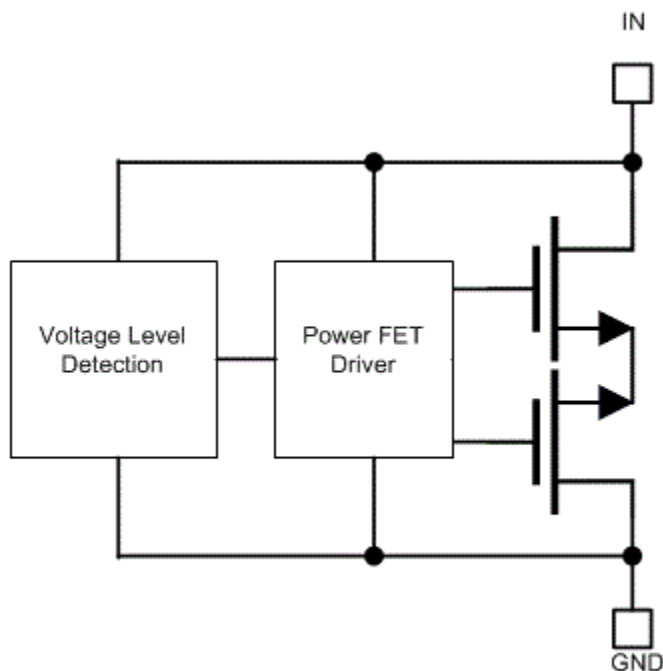

9.3 Feature Description

The TVS1401 is a precision clamp that handles ± 30 A of IEC 61000-4-5 8/20 μ s surge pulse. The flat clamping feature helps keep the clamping voltage very low to keep the downstream circuits from being stressed. The flat clamping feature can also help end-equipment designers save cost by opening up the possibility to use lower-cost, lower voltage tolerant downstream ICs. This device provides a bidirectional operating range, with a symmetrical V_{RWM} of ± 14 V, which is designed for applications that have bipolar input signals or that must withstand reverse wiring conditions. The TVS1401 has minimal leakage at V_{RWM} designed for applications where low leakage and power dissipation is a necessity. Built-in IEC 61000-4-2 and IEC 61000-4-4 ratings make it a robust protection solution for ESD and EFT events, and the TVS1401 wide ambient temperature range of -40°C to $+125^{\circ}\text{C}$ enables usage in harsh industrial environments.

9.4 Device Functional Modes

9.4.1 Protection Specifications

The TVS1401 is specified according to both the IEC 61000-4-5 and IEC 61643-321 standards. This enables usage in systems regardless of which standard is required by relevant product standards or best matches measured fault conditions. The IEC 61000-4-5 standard requires protection against a pulse with a rise time of 8 μ s and a half-length of 20 μ s, while the IEC 61643-321 standard requires protection against a much longer pulse with a rise time of 10 μ s and a half-length of 1000 μ s.

The positive and negative surges are imposed to the TVS1401 by a combination wave generator (CWG) with a 2- Ω coupling resistor at different peak voltage levels. For powered-on transient tests that need power supply bias, inductances are used to decouple the transient stress and protect the power supply. The TVS1401 is post-tested by assuring that there is no shift in device breakdown or leakage at V_{RWM} .

In addition, the TVS1401 has been tested according to IEC 61000-4-5 to pass a ± 1 -kV surge test through a 42- Ω coupling resistor and a 0.5- μ F capacitor. This test is a common test requirement for industrial signal I/O lines and the TVS1401 precision clamp can be used in applications that have that requirement.

The TVS1401 integrates IEC 61000-4-2 level 4 ESD Protection and 80 A of IEC 61000-4-4 EFT Protection. These combine to ensure that the device can protect against most common transient test requirements.

For more information on TI's test methods for Surge, ESD, and EFT testing, refer to the [TI's IEC 61000--4-x Tests for TI's Protection Devices](#) application report.

9.4.2 Reliability Testing

To ensure device reliability, the TVS1401 is characterized against 5,000 repetitive pulses of 25-A IEC 61000-4-5 8/20- μ s surge pulses at 125°C. The test is performed with less than 10 seconds between each pulse at high temperature to simulate worst-case scenarios for fault regulation. After each surge pulse, the TVS1401 clamping voltage, breakdown voltage, and leakage are recorded to ensure that there is no variation or performance degradation. By ensuring robust, reliable, high temperature protection, the TVS1401 enables fault protection in applications that must withstand years of continuous operation with no performance change.

9.4.3 Zero Derating

Unlike traditional diodes, the TVS1401 has zero derating of maximum power dissipation and ensures robust performance up to 125°C. Traditional TVS diodes lose up to 50% of their current carrying capability when at high temperatures, so a surge pulse above 85°C ambient can cause failures that are not seen at room temperature. The TVS1401 prevents this so the designer can see the surge protection regardless of temperature. Because of this, Flat-Clamp devices can provide robust protection against surge pulses that occur at high ambient temperatures, as shown in TI's [TVS Surge Protection in High-Temperature Environments](#) application report.

9.4.4 Bidirectional Operation

The TVS1401 is a bidirectional TVS with a symmetrical operating region. This allows for operation with positive and negative voltages, rather than just positive voltages like the unidirectional TVS1400. This allows for single chip protection for applications where the signal is expected to operate below 0 V or where there is a need to withstand a large common-mode voltage. In addition, in many cases, there is a system requirement to be able to withstand reverse wiring conditions, in many cases where a high voltage signal is accidentally applied to the system ground and a ground is accidentally applied to the input terminal. This causes a large reverse voltage on the TVS diode that the device must be able to withstand. The TVS1401 is designed to not break down or see failures under reverse wiring conditions for applications that must withstand these miswiring issues.

Note

If the applied signal is not expected to go below 0 V, an unidirectional device will clamp much lower in the reverse direction and should be used. In this case, the recommended device would be the TVS1400.

9.4.5 Transient Performance

During large transient swings, the TVS1401 will begin clamping the input signal to protect downstream conditions. While this prevents damage during fault conditions, it can cause leakage when the intended input signal has a fast slew rate. To keep power dissipation low and remove the chance of signal distortion, TI recommends that the designer keep the slew rate of any input signal on the TVS1401 below 2.5 V/ μ s at room temperature and below 1 V/ μ s at 85°C as shown in [Figure 8-6](#). Faster slew rates will cause the device to clamp the input signal and draw current through the device for a few microseconds, increasing the rise time of the signal. This will not cause any harm to the system or to the device, however, it can cause device overheating if the fast input voltage swings occur regularly.

10 Application and Implementation

Note

Information in the following applications sections is not part of the TI component specification, and TI does not warrant its accuracy or completeness. TI's customers are responsible for determining suitability of components for their purposes, as well as validating and testing their design implementation to confirm system functionality.

10.1 Application Information

The TVS1401 can be used to protect any power, analog, or digital signal from transient fault conditions caused by the environment or other electrical components.

10.2 Typical Application

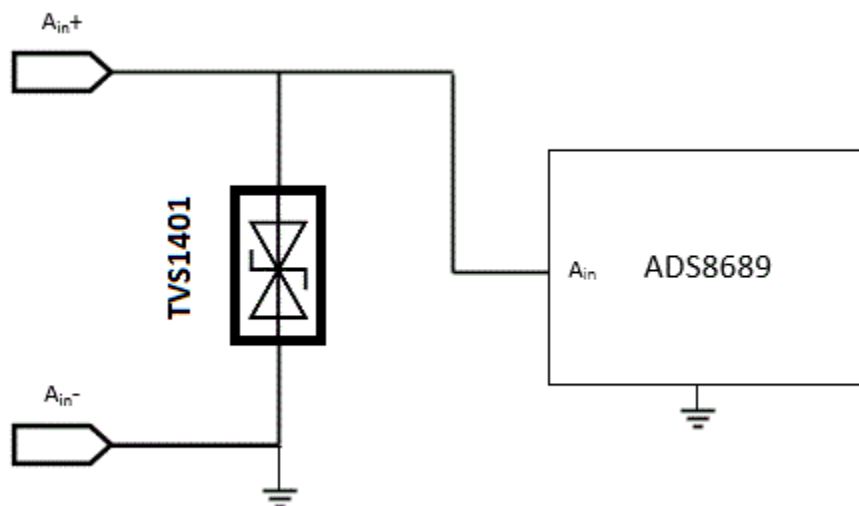

Figure 10-1. TVS1401 Application Schematic

10.2.1 Design Requirements

A typical operation for the TVS1401 would be protecting in a factory control application and protecting an analog input to an ADC input similar to Figure 10-1. In this example, the TVS1401 is protecting the input to an ADS8689, an ADC with an input voltage range of ± 12.288 V and an absolute maximum input voltage range of ± 20 V. Without any input protection, this input voltage will rise to hundreds of volts for multiple microseconds, and violate the absolute maximum input voltage and harm the device if a surge event is caused by lightning, coupling, ringing, or any other fault condition. TI's Flat-Clamp technology provides surge protection diodes that can maximize the useable voltage range at a safe level for the system.

10.2.2 Detailed Design Procedure

If the TVS1401 is in place to protect the device, the voltage will rise to the breakdown of the diode at 17.6 V during a surge event. The TVS0701 will then turn on to shunt the surge current to ground. With the low dynamic resistance of the TVS1401, large amounts of surge current will have minimal impact on the clamping voltage. The dynamic resistance of the TVS1401 is around 70 m Ω , which means a 25-A surge current will cause a voltage raise of $25 \text{ A} \times 70 \text{ m}\Omega = 1.75 \text{ V}$. Because the device turns on at 17.6 V, this means the ADC input will be exposed to a maximum of $17.6 \text{ V} + 1.75 \text{ V} = 19.35 \text{ V}$ during surge pulses, well within the ADS8689 absolute maximum to ensure robust protection of the circuit. The same magnitude of voltage will be seen during a negative pulse, still safely protecting the system.

In addition, the low leakage and capacitance of the TVS1401 assures low input distortion. At 14 V, giving margin on the ± 12.288 V range of the ADS8689, the device will see typical 1.1-nA leakage, which will have minimal effect on the overall system. The TVS1401 low capacitance of 68 pF will also cause less effect on signal integrity compared to industry standard devices like the SMBJ14CA which has 1500 pF of capacitance and can cause up to 3 dB of THD attenuation in measured systems.

Finally, the small size of the device also improves fault protection by lowering the effect of fault current coupling onto neighboring traces. The small form factor of the TVS1401 allows the device to be placed extremely close to the input connector, which lowers the length of the path fault current going through the system compared to larger protection solutions.

10.2.3 Application Curves

When a surge is applied to a system with the TVS1401, the device will clamp the overvoltage to a safe level as shown in Figure 10-2.

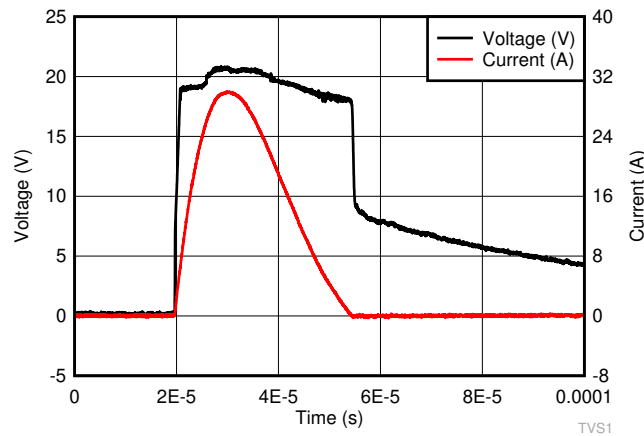

Figure 10-2. TVS1401 Surge Clamping Response

11 Power Supply Recommendations

The TVS1401 is a clamping device so there is no need to power it. To ensure the device functions properly, do not violate the recommended V_{IN} voltage range (-14 V to 14 V).

12 Layout

12.1 Layout Guidelines

The optimum placement is close to the connector. EMI during an ESD event can couple from the tested trace to other nearby unprotected traces, which could result in system failures. The PCB designer must minimize the possibility of EMI coupling by keeping all unprotected traces away from protected traces between the TVS and the connector. Route the protected traces straight. Use rounded corners with the largest radii possible to eliminate any sharp corners on the protected traces between the TVS1401 and the connector. Electric fields tend to build up on corners, which could increase EMI coupling.

Ensure that the thermal pad on the layout is floating rather than grounded. Grounding the thermal pad will impede the operating range of the TVS1401 and can cause failures when the applied voltage is negative. A floating thermal pad allows the maximum operating range without sacrificing any transient performance.

12.2 Layout Example

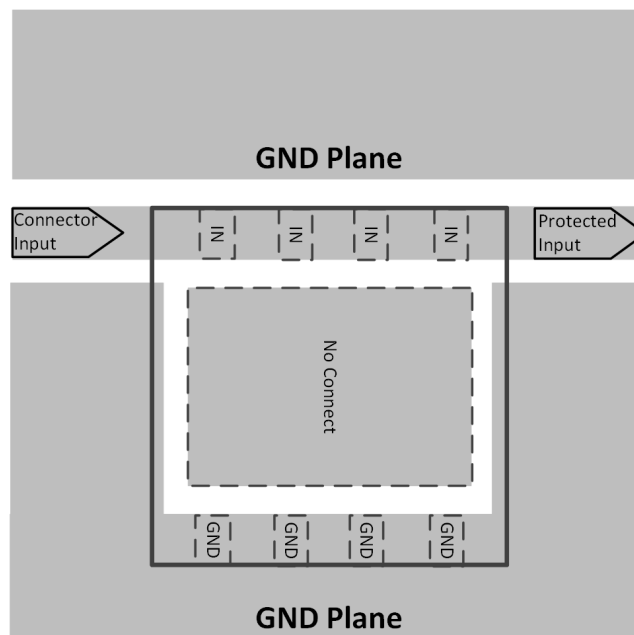

Figure 12-1. TVS1401 Layout

13 Device and Documentation Support

13.1 Documentation Support

13.1.1 Related Documentation

For related documentation, see the following:

- Texas Instruments, [Flat-Clamp Surge Protection Technology for Efficient System Protection white paper](#)
- Texas Instruments, [TI's IEC 61000--4-x Tests for TI's Protection Devices application report](#)
- Texas Instruments, [TVS Surge Protection in High-Temperature Environments application report](#)
- Texas Instruments, [TVS1401 Functional Safety, FIT Rate, Failure Mode Distribution and Pin FMA](#)

13.2 Receiving Notification of Documentation Updates

To receive notification of documentation updates, navigate to the device product folder on [ti.com](#). Click on [Subscribe to updates](#) to register and receive a weekly digest of any product information that has changed. For change details, review the revision history included in any revised document.

13.3 Support Resources

[TI E2E™ support forums](#) are an engineer's go-to source for fast, verified answers and design help — straight from the experts. Search existing answers or ask your own question to get the quick design help you need.

Linked content is provided "AS IS" by the respective contributors. They do not constitute TI specifications and do not necessarily reflect TI's views; see TI's [Terms of Use](#).

13.4 Trademarks

TI E2E™ is a trademark of Texas Instruments.

All trademarks are the property of their respective owners.

13.5 Electrostatic Discharge Caution



This integrated circuit can be damaged by ESD. Texas Instruments recommends that all integrated circuits be handled with appropriate precautions. Failure to observe proper handling and installation procedures can cause damage.

ESD damage can range from subtle performance degradation to complete device failure. Precision integrated circuits may be more susceptible to damage because very small parametric changes could cause the device not to meet its published specifications.

13.6 Glossary

[TI Glossary](#) This glossary lists and explains terms, acronyms, and definitions.

14 Mechanical, Packaging, and Orderable Information

The following pages include mechanical, packaging, and orderable information. This information is the most current data available for the designated devices. This data is subject to change without notice and revision of this document. For browser-based versions of this data sheet, refer to the left-hand navigation.

PACKAGING INFORMATION

Orderable part number	Status (1)	Material type (2)	Package Pins	Package qty Carrier	RoHS (3)	Lead finish/ Ball material (4)	MSL rating/ Peak reflow (5)	Op temp (°C)	Part marking (6)
TVS1401DRBR	Active	Production	SON (DRB) 8	3000 LARGE T&R	Yes	NIPDAU	Level-2-260C-1 YEAR	-40 to 125	1PSP
TVS1401DRBR.A	Active	Production	SON (DRB) 8	3000 LARGE T&R	Yes	NIPDAU	Level-2-260C-1 YEAR	-40 to 125	1PSP

(1) **Status:** For more details on status, see our [product life cycle](#).

(2) **Material type:** When designated, preproduction parts are prototypes/experimental devices, and are not yet approved or released for full production. Testing and final process, including without limitation quality assurance, reliability performance testing, and/or process qualification, may not yet be complete, and this item is subject to further changes or possible discontinuation. If available for ordering, purchases will be subject to an additional waiver at checkout, and are intended for early internal evaluation purposes only. These items are sold without warranties of any kind.

(3) **RoHS values:** Yes, No, RoHS Exempt. See the [TI RoHS Statement](#) for additional information and value definition.

(4) **Lead finish/Ball material:** Parts may have multiple material finish options. Finish options are separated by a vertical ruled line. Lead finish/Ball material values may wrap to two lines if the finish value exceeds the maximum column width.

(5) **MSL rating/Peak reflow:** The moisture sensitivity level ratings and peak solder (reflow) temperatures. In the event that a part has multiple moisture sensitivity ratings, only the lowest level per JEDEC standards is shown. Refer to the shipping label for the actual reflow temperature that will be used to mount the part to the printed circuit board.

(6) **Part marking:** There may be an additional marking, which relates to the logo, the lot trace code information, or the environmental category of the part.

Multiple part markings will be inside parentheses. Only one part marking contained in parentheses and separated by a "~" will appear on a part. If a line is indented then it is a continuation of the previous line and the two combined represent the entire part marking for that device.

Important Information and Disclaimer:The information provided on this page represents TI's knowledge and belief as of the date that it is provided. TI bases its knowledge and belief on information provided by third parties, and makes no representation or warranty as to the accuracy of such information. Efforts are underway to better integrate information from third parties. TI has taken and continues to take reasonable steps to provide representative and accurate information but may not have conducted destructive testing or chemical analysis on incoming materials and chemicals. TI and TI suppliers consider certain information to be proprietary, and thus CAS numbers and other limited information may not be available for release.

In no event shall TI's liability arising out of such information exceed the total purchase price of the TI part(s) at issue in this document sold by TI to Customer on an annual basis.

TAPE AND REEL INFORMATION

QUADRANT ASSIGNMENTS FOR PIN 1 ORIENTATION IN TAPE

*All dimensions are nominal

Device	Package Type	Package Drawing	Pins	SPQ	Reel Diameter (mm)	Reel Width W1 (mm)	A0 (mm)	B0 (mm)	K0 (mm)	P1 (mm)	W (mm)	Pin1 Quadrant
TVS1401DRBR	SON	DRB	8	3000	330.0	12.4	3.3	3.3	1.1	8.0	12.0	Q2

TAPE AND REEL BOX DIMENSIONS

*All dimensions are nominal

Device	Package Type	Package Drawing	Pins	SPQ	Length (mm)	Width (mm)	Height (mm)
TVS1401DRBR	SON	DRB	8	3000	338.0	355.0	35.0

DRB 8

GENERIC PACKAGE VIEW

VSON - 1 mm max height

PLASTIC SMALL OUTLINE - NO LEAD

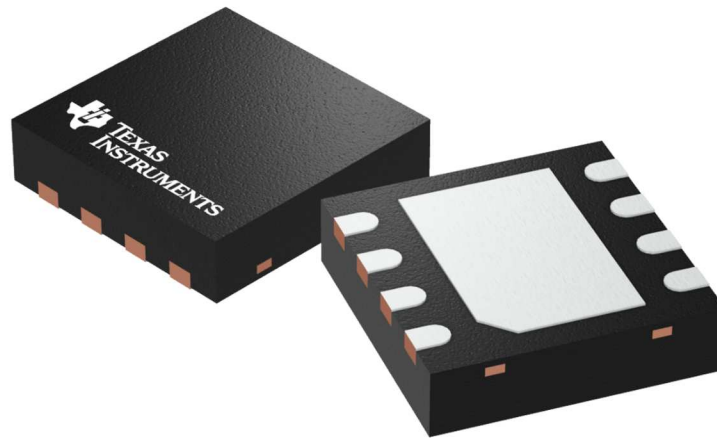

Images above are just a representation of the package family, actual package may vary.
Refer to the product data sheet for package details.

4203482/L

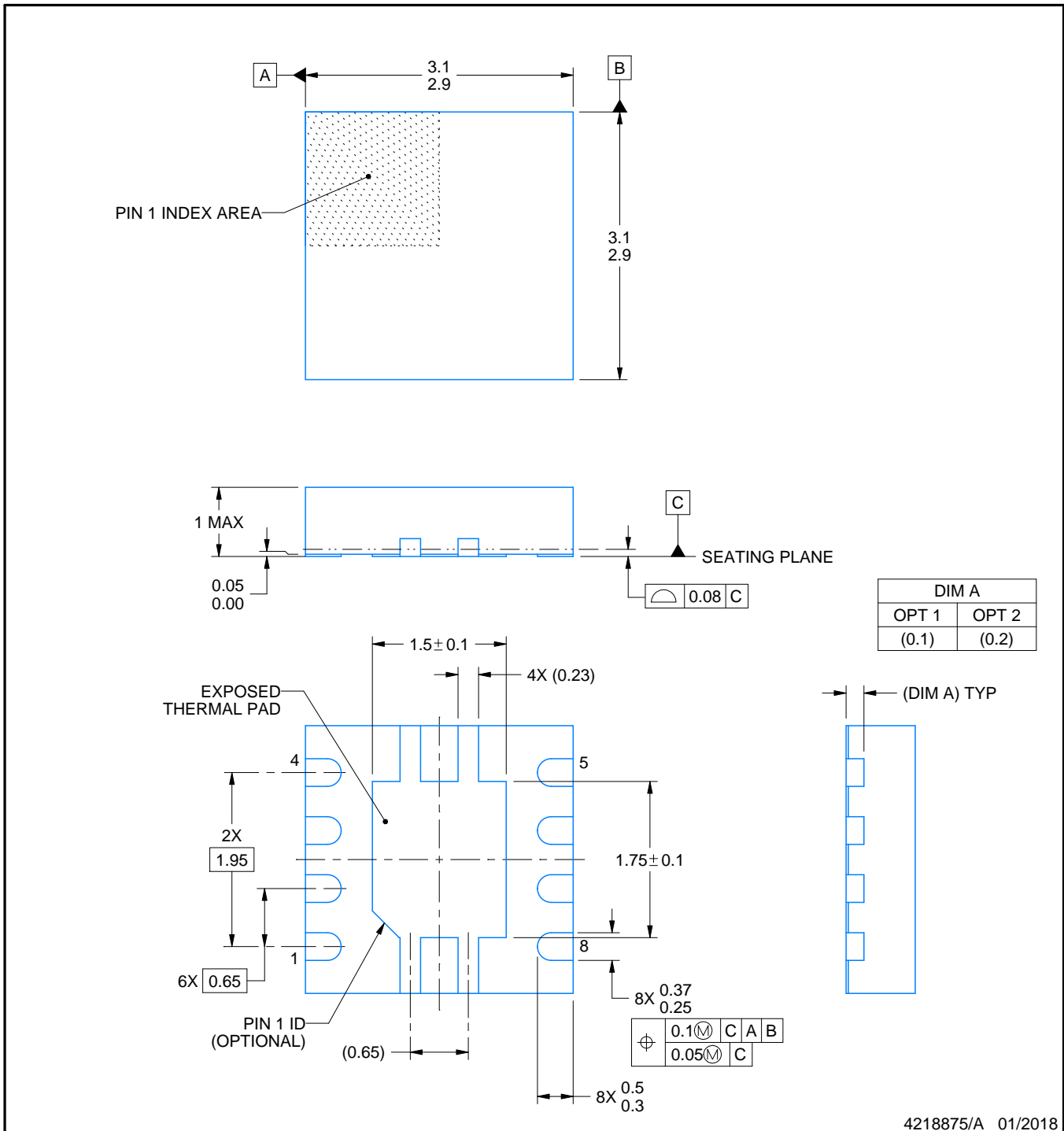

4218875/A 01/2018

NOTES:

1. All linear dimensions are in millimeters. Any dimensions in parenthesis are for reference only. Dimensioning and tolerancing per ASME Y14.5M.
2. This drawing is subject to change without notice.
3. The package thermal pad must be soldered to the printed circuit board for thermal and mechanical performance.

EXAMPLE BOARD LAYOUT

DRB0008A

VSON - 1 mm max height

PLASTIC SMALL OUTLINE - NO LEAD

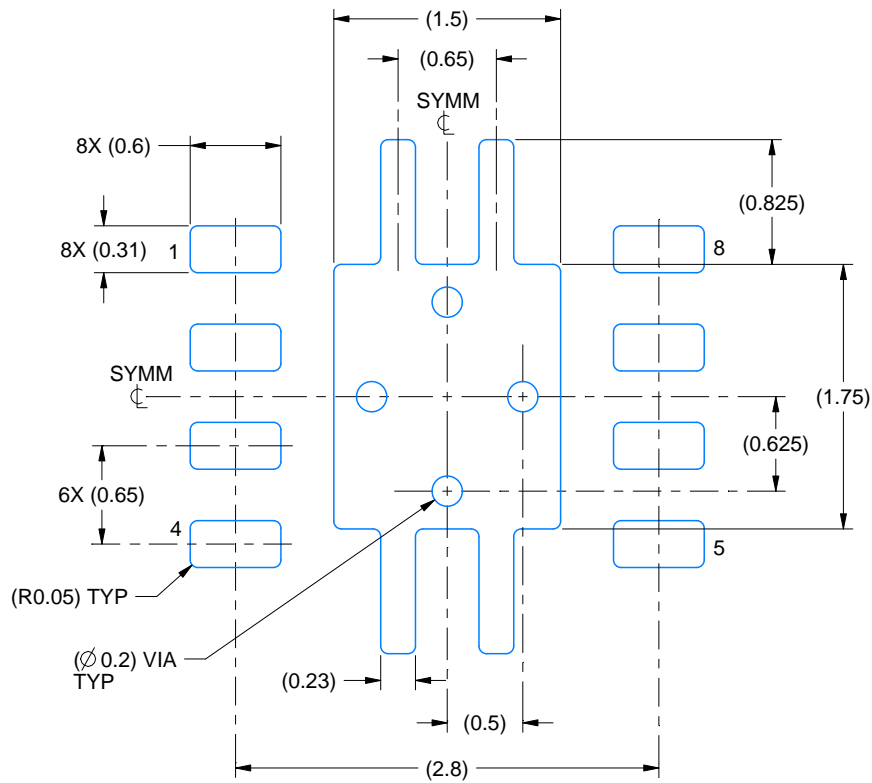

LAND PATTERN EXAMPLE
EXPOSED METAL SHOWN
SCALE:20X

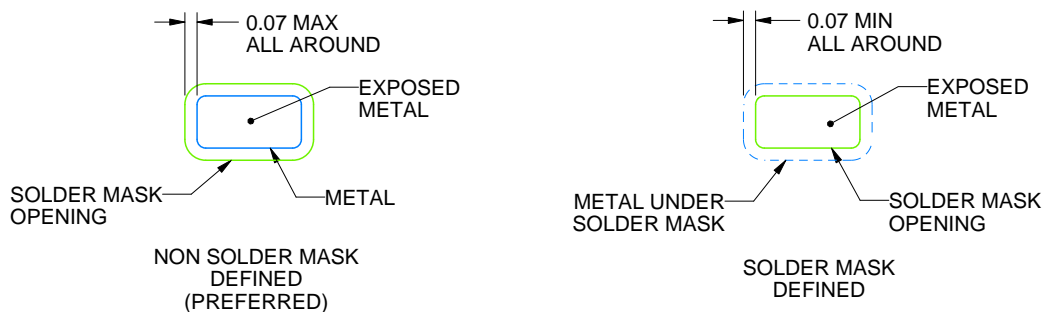

SOLDER MASK DETAILS

4218875/A 01/2018

NOTES: (continued)

4. This package is designed to be soldered to a thermal pad on the board. For more information, see Texas Instruments literature number SLUA271 (www.ti.com/lit/slua271).
5. Vias are optional depending on application, refer to device data sheet. If any vias are implemented, refer to their locations shown on this view. It is recommended that vias under paste be filled, plugged or tented.

EXAMPLE STENCIL DESIGN

DRB0008A

VSON - 1 mm max height

PLASTIC SMALL OUTLINE - NO LEAD

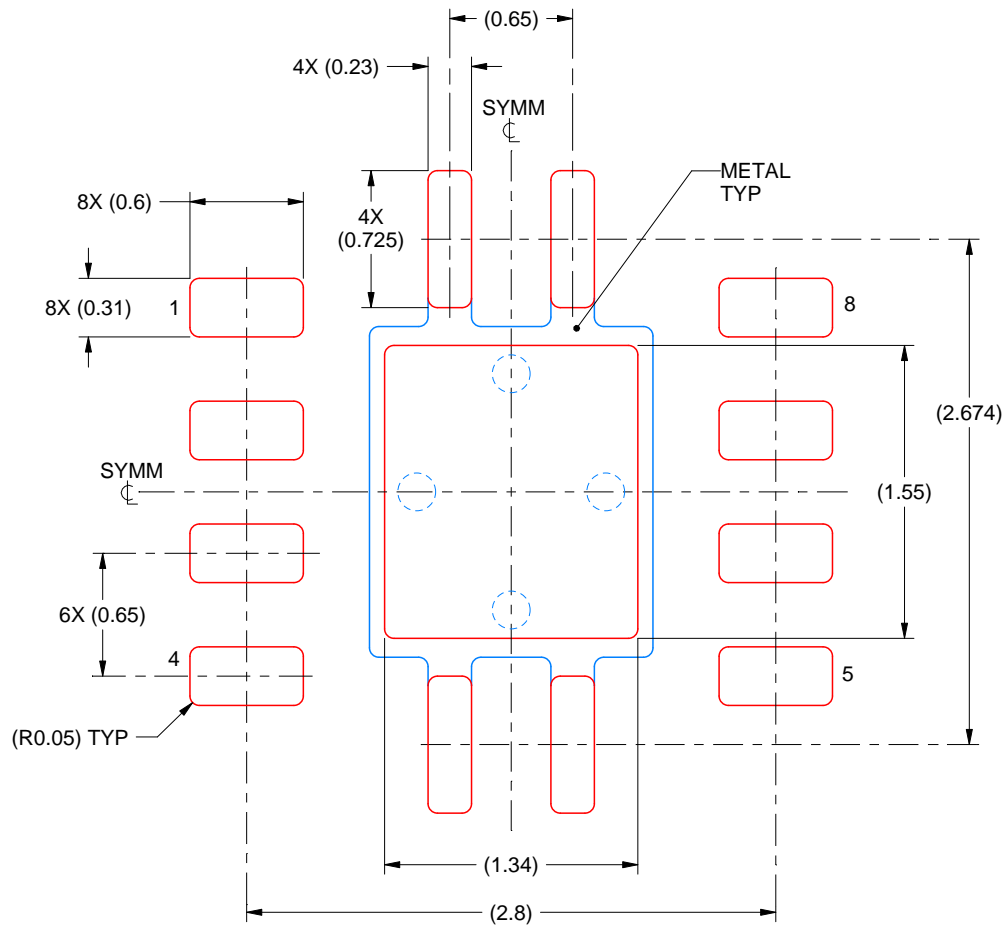

SOLDER PASTE EXAMPLE
BASED ON 0.125 mm THICK STENCIL

EXPOSED PAD
84% PRINTED SOLDER COVERAGE BY AREA
SCALE:25X

4218875/A 01/2018

NOTES: (continued)

6. Laser cutting apertures with trapezoidal walls and rounded corners may offer better paste release. IPC-7525 may have alternate design recommendations.

IMPORTANT NOTICE AND DISCLAIMER

TI PROVIDES TECHNICAL AND RELIABILITY DATA (INCLUDING DATASHEETS), DESIGN RESOURCES (INCLUDING REFERENCE DESIGNS), APPLICATION OR OTHER DESIGN ADVICE, WEB TOOLS, SAFETY INFORMATION, AND OTHER RESOURCES "AS IS" AND WITH ALL FAULTS, AND DISCLAIMS ALL WARRANTIES, EXPRESS AND IMPLIED, INCLUDING WITHOUT LIMITATION ANY IMPLIED WARRANTIES OF MERCHANTABILITY, FITNESS FOR A PARTICULAR PURPOSE OR NON-INFRINGEMENT OF THIRD PARTY INTELLECTUAL PROPERTY RIGHTS.

These resources are intended for skilled developers designing with TI products. You are solely responsible for (1) selecting the appropriate TI products for your application, (2) designing, validating and testing your application, and (3) ensuring your application meets applicable standards, and any other safety, security, regulatory or other requirements.

These resources are subject to change without notice. TI grants you permission to use these resources only for development of an application that uses the TI products described in the resource. Other reproduction and display of these resources is prohibited. No license is granted to any other TI intellectual property right or to any third party intellectual property right. TI disclaims responsibility for, and you fully indemnify TI and its representatives against any claims, damages, costs, losses, and liabilities arising out of your use of these resources.

TI's products are provided subject to [TI's Terms of Sale](#), [TI's General Quality Guidelines](#), or other applicable terms available either on ti.com or provided in conjunction with such TI products. TI's provision of these resources does not expand or otherwise alter TI's applicable warranties or warranty disclaimers for TI products. Unless TI explicitly designates a product as custom or customer-specified, TI products are standard, catalog, general purpose devices.

TI objects to and rejects any additional or different terms you may propose.

Copyright © 2026, Texas Instruments Incorporated

Last updated 10/2025