

# TXS0204 4-Bit Bidirectional Voltage-Level Translator for Open-Drain and Push-Pull Applications

## 1 Features

- No direction-control signal needed
- Maximum data rates:
  - 50Mbps (push pull)
  - 2Mbps (open drain)
- Available in the Texas Instruments NanoFree™ package
- 1.1V to 3.6V on A port and 1.65V to 5.5V on B port
- No power-supply sequencing required – either VCCA or VCCB can be ramped first
- VCCA can be >, =, < VCCB
- Latch-up performance exceeds 100mA per JESD 78, class II
- ESD protection exceeds JESD 22:
  - A port:
    - 2000V Human-Body Model (A114-B)
    - 200V Machine Model (A115-A)
    - 1000V Charged-Device Model (C101)
  - B port:
    - 4kV Human-Body Model (A114-B)
    - 200V Machine Model (A115-A)
    - 1000V Charged-Device Model (C101)

## 2 Applications

- [Handset](#)
- [Smartphone](#)
- [Tablet](#)
- [Desktop PC](#)

## 3 Description

This 4-bit non-inverting translator uses two separate configurable power-supply rails. The A port is designed to track VCCA. VCCA accepts any supply voltage from 1.1V to 3.6V. The B port is designed to track VCCB. VCCB accepts any supply voltage from 1.65V to 5.5V. This allows for low-voltage bidirectional translation between any of the 1.1V, 1.8V, 2.0V, 3.3V, and 5V voltage nodes.

When the output-enable (OE) input is low, all outputs are placed in the high-impedance state.

The TXS0204 is designed so that the OE input circuit is supplied by VCCA.

For the high-impedance state during power up or power down, tie OE to GND through a pull-down resistor; the minimum value of the resistor is determined by the current-sourcing capability of the driver.

### Package Information

PART NUMBER	PACKAGE <sup>(1)</sup>	PACKAGE SIZE <sup>(2)</sup>
TXS0204	YCJ (DSBGA, 14)	1.4mm × 1.05mm

- (1) For all available packages, see the orderable addendum at the end of the data sheet.
- (2) The package size (length × width) is a nominal value and includes pins, where applicable

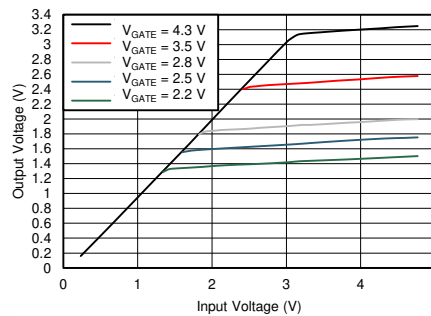

Transfer Characteristics of an N-Channel Transistor



## Table of Contents

<b>1 Features</b> .....	<b>1</b>	<b>7 Detailed Description</b> .....	<b>20</b>
<b>2 Applications</b> .....	<b>1</b>	7.1 Overview.....	20
<b>3 Description</b> .....	<b>1</b>	7.2 Functional Block Diagram.....	20
<b>4 Pin Configuration and Functions</b> .....	<b>3</b>	7.3 Feature Description.....	21
<b>5 Specifications</b> .....	<b>4</b>	7.4 Device Functional Modes.....	21
5.1 Absolute Maximum Ratings.....	4	<b>8 Application and Implementation</b> .....	<b>22</b>
5.2 ESD Ratings.....	4	8.1 Application Information.....	22
5.3 Recommended Operating Conditions.....	5	8.2 Typical Application.....	22
5.4 Thermal Information.....	5	8.3 Power Supply Recommendations.....	24
5.5 Electrical Characteristics.....	6	8.4 Layout.....	24
5.6 Electrical Characteristics (Cont.).....	7	<b>9 Device and Documentation Support</b> .....	<b>26</b>
5.7 Switching Characteristics, $V_{CCA} = 1.2 \pm 0.1V$ .....	7	9.1 Documentation Support.....	26
5.8 Switching Characteristics, $V_{CCA} = 1.5 \pm 0.1V$ .....	9	9.2 Receiving Notification of Documentation Updates.....	26
5.9 Switching Characteristics, $V_{CCA} = 1.8 \pm 0.15V$ .....	10	9.3 Support Resources.....	26
5.10 Switching Characteristics, $V_{CCA} = 2.5 \pm 0.2V$ .....	11	9.4 Trademarks.....	26
5.11 Switching Characteristics, $V_{CCA} = 3.3 \pm 0.3V$ .....	12	9.5 Electrostatic Discharge Caution.....	26
5.12 Switching Characteristics: $T_{sk}$ , $T_{MAX}$ .....	14	9.6 Glossary.....	26
5.13 Typical Characteristics.....	16	<b>10 Revision History</b> .....	<b>26</b>
<b>6 Parameter Measurement Information</b> .....	<b>17</b>	<b>11 Mechanical, Packaging, and Orderable Information</b> .....	<b>27</b>
6.1 Load Circuits.....	17		
6.2 Voltage Waveforms.....	19		

## 4 Pin Configuration and Functions

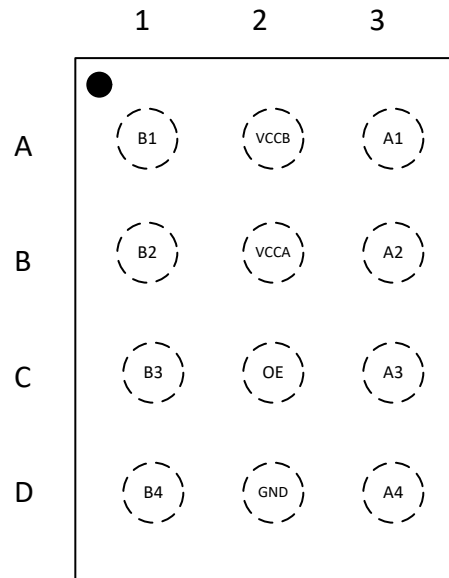

**Figure 4-1. YCJ Package, 12-Pin DSBGA (Top View)**

**Table 4-1. Pin Functions: DSBGA**

PIN		TYPE	DESCRIPTION
NO.	NAME		
A3	A1	I/O	Input/output A1. Referenced to $V_{CCA}$ .
B3	A2	I/O	Input/output A2. Referenced to $V_{CCA}$ .
C3	A3	I/O	Input/output A3. Referenced to $V_{CCA}$ .
D3	A4	I/O	Input/output A4. Referenced to $V_{CCA}$ .
A1	B1	I/O	Input/output B1. Referenced to $V_{CCB}$ .
B1	B2	I/O	Input/output B2. Referenced to $V_{CCB}$ .
C1	B3	I/O	Input/output B3. Referenced to $V_{CCB}$ .
D1	B4	I/O	Input/output B4. Referenced to $V_{CCB}$ .
D2	GND	—	Ground
C2	OE	I	3-state output-mode enable. Pull OE low to place all outputs in 3-state mode. Referenced to $V_{CCA}$ .
B2	$V_{CCA}$	—	A-port supply voltage. $1.1V \leq V_{CCA} \leq 3.6V$ and $V_{CCA} \leq V_{CCB}$ .
A2	$V_{CCB}$	—	B-port supply voltage. $1.65V \leq V_{CCB} \leq 5.5V$ .

## 5 Specifications

### 5.1 Absolute Maximum Ratings

over operating free-air temperature range (unless otherwise noted)<sup>(1)</sup>

			MIN	MAX	UNIT
V <sub>CCA</sub>	Supply voltage A		-0.5	4.6	V
V <sub>CCB</sub>	Supply voltage B		-0.5	6.5	V
V <sub>I</sub>	Input Voltage <sup>(2)</sup>	I/O Ports (A Port)	-0.5	4.6	V
		I/O Ports (B Port)	-0.5	6.5	
V <sub>I</sub>	Input Voltage <sup>(2)</sup>	OE	-0.5	6.5	V
V <sub>O</sub>	Voltage applied to any output in the high-impedance or power-off state <sup>(2)</sup>	A Port	-0.5	4.6	V
		B Port	-0.5	6.5	
V <sub>O</sub>	Voltage applied to any output in the high or low state <sup>(2) (3)</sup>	A Port	-0.5	V <sub>CCA</sub> + 0.5	V
		B Port	-0.5	V <sub>CCB</sub> + 0.5	
I <sub>IK</sub>	Input clamp current	V <sub>I</sub> < 0	-50		mA
I <sub>OK</sub>	Output clamp current	V <sub>O</sub> < 0	-50		mA
I <sub>O</sub>	Continuous output current		-50	50	mA
	Continuous current through V <sub>CC</sub> or GND		-100	100	
T <sub>j</sub>	Junction Temperature			150	°C
T <sub>stg</sub>	Storage temperature		-65	150	°C

- (1) Stresses beyond those listed under [Section 5.1](#) may cause permanent damage to the device. These are stress ratings only, which do not imply functional operation of the device at these or any other conditions beyond those indicated under [Section 5.3](#) Exposure beyond the limits listed in [Section 5.3](#) may affect device reliability.
- (2) The input voltage and output negative-voltage ratings may be exceeded if the input and output current ratings are observed.
- (3) The output positive-voltage rating may be exceeded up to 6.5V maximum if the output current rating is observed.

### 5.2 ESD Ratings

				VALUE	UNIT
V <sub>(ESD)</sub>	Electrostatic discharge	Human body model (HBM), per ANSI/ESDA/JEDEC JS-001	A Port	±2000	V
			B Port	±4000	
		Charged device model (CDM), per ANSI/ESDA/JEDEC JS-002	A Port	±1000	
			B Port	±1000	

### 5.3 Recommended Operating Conditions

over operating free-air temperature range (unless otherwise noted) <sup>(1)</sup> <sup>(2)</sup> <sup>(3)</sup>

		$V_{CCA}$	$V_{CCB}$	MIN	MAX	UNIT
$V_{CCA}$	Supply voltage A			1.1	3.6	V
$V_{CCB}$	Supply voltage B			1.65	5.5	V
OS	One-Shot Activation Threshold	A-port I/O's	1.1V to 3.6V	1.65V to 5.5V	$V_{CCI} \times 0.30$	V
		B-port I/O's	1.1V to 3.6V	1.65V to 5.5V	$V_{CCI} \times 0.30$	
$\Delta t/\Delta v$	Input transition rise and fall time	Push-Pull Driving	1.1V to 3.6V	1.65V to 5.5V	10	ns/V
$T_A$	Operating free-air temperature			-40	125	°C

- (1)  $V_{CCI}$  is the  $V_{CC}$  associated with the input port.
- (2)  $V_{CCO}$  is the  $V_{CC}$  associated with the output port.
- (3) All control inputs and data I/Os of this device have weak pulldowns to make sure the line is not floating when undefined external to the device. The input leakage from these weak pulldowns is defined by the  $I_I$  specification indicated under [Section 5.5](#).

### 5.4 Thermal Information

THERMAL METRIC <sup>(1)</sup>		TXS0204	UNIT
		YCJ (DSBGA)	
		12 PINS	
$R_{\theta JA}$	Junction-to-ambient thermal resistance	102.7	°C/W
$R_{\theta JC(top)}$	Junction-to-case (top) thermal resistance	0.7	°C/W
$R_{\theta JB}$	Junction-to-board thermal resistance	26.1	°C/W
$Y_{JT}$	Junction-to-top characterization parameter	0.4	°C/W
$Y_{JB}$	Junction-to-board characterization parameter	26.1	°C/W

- (1) For more information about traditional and new thermal metrics, see the [Semiconductor and IC Package Thermal Metrics](#) application note.

### 5.5 Electrical Characteristics

over operating free-air temperature range (unless otherwise noted). Please see [Figure 6-4](#)

		Test Condition	V <sub>CCA</sub>	V <sub>CCB</sub>	MIN	MAX	UNIT	
V <sub>OH</sub>	High-Level Output Voltage	V <sub>IH</sub> = 0.67V	A	1.1V to 1.3V	1.65V to 1.9V	V <sub>CCA</sub> × 0.7	V	
		V <sub>IH</sub> = 0.72V		1.1V to 1.3V	2.25V to 2.75V	V <sub>CCA</sub> × 0.7	V	
		V <sub>IH</sub> = 0.75V		1.1V to 1.3V	3V to 3.6V	V <sub>CCA</sub> × 0.7	V	
		V <sub>IH</sub> = 0.67V	B	1.1V to 1.3V	1.65V to 1.9V	V <sub>CCB</sub> × 0.7	V	
		V <sub>IH</sub> = 0.73		1.1V to 1.3V	2.25V to 2.75V	V <sub>CCB</sub> × 0.7	V	
		V <sub>IH</sub> = 0.76		1.1V to 1.3V	3V to 3.6V	V <sub>CCB</sub> × 0.7	V	
V <sub>OH</sub>	High-Level Output Voltage	I <sub>OH</sub> = -20μA, V <sub>IB</sub> > V <sub>CCB</sub> - 0.4V	A	1.1V to 3.6V	1.65V to 5.5V	V <sub>CCA</sub> × 0.75	V	
		I <sub>OH</sub> = -20μA, V <sub>IA</sub> > V <sub>CCA</sub> - 0.4V	B	1.1V to 3.6V	1.65V to 5.5V	V <sub>CCB</sub> × 0.75	V	
V <sub>OL</sub>	Low-Level Output Voltage	V <sub>IL</sub> = 0.1V with external 4.7kΩ pull-up resistor	A	1.1V to 1.3V	1.65V to 1.9V		0.112	V
				1.1V to 1.3V	2.25V to 2.75V		0.12	V
				1.1V to 1.3V	3to 3.6V		0.11	V
			B	1.1V to 1.3V	1.65V to 1.9V		0.12	V
				1.1V to 1.3V	2.25V to 2.75V		0.125	V
				1.1V to 1.3V	3to 3.6V		0.13	V
		V <sub>IL</sub> = 0.2V with external 4.7kΩ pull-up resistor	A	1.1V to 1.3V	1.65V to 1.9V		0.215	V
				1.1V to 1.3V	2.25V to 2.75V		0.212	V
				1.1V to 1.3V	3to 3.6V		0.215	V
			B	1.1V to 1.3V	1.65V to 1.9V		0.23	V
				1.1V to 1.3V	2.25V to 2.75V		0.23	V
				1.1V to 1.3V	3to 3.6V		0.24	V
		V <sub>IL</sub> = 0.3V with external 4.7kΩ pull-up resistor	A	1.1V to 1.3V	1.65V to 1.9V		0.34	V
				1.1V to 1.3V	2.25V to 2.75V		0.316	V
				1.1V to 1.3V	3to 3.6V		0.34	V
B	1.1V to 1.3V		1.65V to 1.9V		0.4	V		
	1.1V to 1.3V		2.25V to 2.75V		0.34	V		
	1.1V to 1.3V		3to 3.6V		0.35	V		
V <sub>OL</sub>	Low-Level Output Voltage	I <sub>OL</sub> = 1mA, V <sub>IB</sub> ≤ 0.15V	A	1.1V to 3.6V	1.65V to 5.5V		0.4	V
		I <sub>OL</sub> = 1mA, V <sub>IA</sub> ≤ 0.15V	B	1.1V to 3.6V	1.65V to 5.5V		0.4	V

## 5.6 Electrical Characteristics (Cont.)

over operating free-air temperature range (unless otherwise noted)<sup>(1)</sup> <sup>(2)</sup>

PARAMETER	TEST CONDITIONS	V <sub>CCA</sub>	V <sub>CCB</sub>	Operating free-air temperature (T <sub>A</sub> )									UNIT
				25°C			-40°C to 85°C			-40°C to 125°C			
				MIN	TYP	MAX	MIN	TYP	MAX	MIN	TYP	MAX	
I <sub>I</sub>	Input leakage current OE: V <sub>I</sub> = V <sub>CC</sub> or GND	1.1V to 3.6V	1.65V to 5.5V	-2		2	-2		2	-2		2	μA
I <sub>OZ</sub>	High-impedance state output current A or B Port: V <sub>I</sub> = V <sub>CCi</sub> or GND V <sub>O</sub> = V <sub>CCO</sub> or GND OE = GND	1.1V to 3.6V	1.65V to 5.5V	-1		1	-2		2	-3		3	μA
I <sub>CCA</sub>	V <sub>CCA</sub> supply current V <sub>I</sub> = V <sub>CCi</sub> or GND I <sub>O</sub> = 0	1.1V to 3.6V	1.65V to 5.5V			2.4			3.3			6.2	μA
		3.6V	0V			2.2			2.2			2.2	
		0V	5.5V	-3			-3			-3			
I <sub>CCB</sub>	V <sub>CCB</sub> supply current V <sub>I</sub> = V <sub>CCi</sub> or GND I <sub>O</sub> = 0	1.1V to 3.6V	1.65V to 5.5V			12			12			21	μA
		3.6V	0V	-1			-1			-1			
		0V	5.5V			5			5			8	
I <sub>CCA</sub> + I <sub>CCB</sub>	Combined supply current V <sub>I</sub> = V <sub>CCi</sub> or GND I <sub>O</sub> = 0	1.1V to 3.6V	1.65V to 5.5V			14.4			14.4			25	μA
C <sub>i</sub>	Control Input Capacitance V <sub>I</sub> = 3.3V or GND	3.3V	3.3V			6			6			6	pF
C <sub>io</sub>	Data I/O Capacitance OE = GND, V <sub>O</sub> = 1.65V DC +1MHz -16dBm sine wave	3.3V	3.3V		5	6.5		12	16.5		12	16.5	pF

- (1) V<sub>CCi</sub> is the V<sub>CC</sub> associated with the input port  
(2) V<sub>CCO</sub> is the V<sub>CC</sub> associated with the output port

## 5.7 Switching Characteristics, V<sub>CCA</sub> = 1.2 ± 0.1V

PARAMETER	FROM	TO	Test Conditions	B-Port Supply Voltage (V <sub>CCB</sub> )								UNIT	
				1.8 ± 0.15V		2.5 ± 0.2V		3.3 ± 0.3V		5.0 ± 0.5V			
				MIN	MAX	MIN	MAX	MIN	MAX	MIN	MAX		
t <sub>PHL</sub>	Propagation Delay (High-to-Low)	A	B	Push-Pull	-40°C to 85°C	6.4		6.8		7.7		11.1	ns
					-40°C to 125°C	6.7		7.3		8.3		9.8	
				Open-Drain	-40°C to 85°C	6.8		7.8		9.3		11.9	
					-40°C to 125°C	7.2		8.4		10		12.7	
t <sub>PLH</sub>	Propagation Delay (Low-to-High)	A	B	Push-Pull	-40°C to 85°C	20.4		20.9		43.1		100.1	
					-40°C to 125°C	16		13.8		15.3		29.5	
				Open-Drain	-40°C to 85°C	92.7		91.5		110.2		241	
					-40°C to 125°C	58.7		53.1		49		55.2	

PARAMETER		FROM	TO	Test Conditions		B-Port Supply Voltage (V <sub>CCB</sub> )								UNIT		
						1.8 ± 0.15V		2.5 ± 0.2V		3.3 ± 0.3V		5.0 ± 0.5V				
						MIN	MAX	MIN	MAX	MIN	MAX	MIN	MAX			
t <sub>PHL</sub>	Propagation Delay (High-to-Low)	B	A	Push-Pull	-40°C to 85°C	3.8	3.7	4.1	5.3	ns						
					-40°C to 125°C	3.9	3.9	4.3	5.5							
				Open-Drain	-40°C to 85°C	3.9	4.1	4.7	6							
					-40°C to 125°C	4.1	4.3	4.9	6.2							
t <sub>PLH</sub>	Propagation Delay (Low-to-High)			B	A	Push-Pull	-40°C to 85°C	10.7	0.5		0.1	0.5	ns			
							-40°C to 125°C	1.4	0.6		0.2	0.5				
						Open-Drain	-40°C to 85°C	0.6	0.5		0.5	0.5				
							-40°C to 125°C	0.6	0.5		0.5	0.5				
t <sub>en</sub>	Enable Time	OE	A or B				-40°C to 85°C	350	216.9	165.9	260	ns				
							-40°C to 125°C	260	179.5	142.5	107					
t <sub>dis</sub>	Disable Time					OE	A or B		-40°C to 85°C	300	300			300	260	ns
									-40°C to 125°C	260	200			250	250	
t <sub>rA</sub>	Output Rise Time	B	A	Push-Pull	-40°C to 85°C			32	24.8	22.5	22	ns				
					-40°C to 125°C			22.7	18.4	16.3	14.2					
				Open-Drain	-40°C to 85°C	295.9	243.4	226	200.8							
					-40°C to 125°C	221.5	173.3	145.9	119.4							
t <sub>rB</sub>	Output Rise Time			A	B	Push-Pull	-40°C to 85°C	23.5	22.8	44.1	28		ns			
							-40°C to 125°C	20.6	16.8	15.9	22.1					
						Open-Drain	-40°C to 85°C	164.2	143.7	128.8	280.1					
							-40°C to 125°C	148.1	108.4	81.6	55.5					
t <sub>fA</sub>	Output Fall Time	B	A			Push-Pull	-40°C to 85°C	5.2	4.4	4.3	6.7	ns				
							-40°C to 125°C	5.6	4.8	4.7	5					
						Open-Drain	-40°C to 85°C	5.7	5	5.3	5.9					
							-40°C to 125°C	6.1	5.5	5.8	6.4					
t <sub>fB</sub>	Output Fall Time			A	B	Push-Pull	-40°C to 85°C	11.2	12	14	14		ns			
							-40°C to 125°C	12	13.1	15.2	19.9					
						Open-Drain	-40°C to 85°C	12.2	14.1	17.6	24.9					
							-40°C to 125°C	13.2	15.4	19.1	26.7					

### 5.8 Switching Characteristics, $V_{CCA} = 1.5 \pm 0.1V$

PARAMETER	FROM	TO	Test Conditions	B-Port Supply Voltage ( $V_{CCB}$ )												UNIT
				1.8 ± 0.15V			2.5 ± 0.2V			3.3 ± 0.3V			5.0 ± 0.5V			
				MIN	TYP	MAX	MIN	TYP	MAX	MIN	TYP	MAX	MIN	TYP	MAX	
$t_{PHL}$	Propagation Delay (Hight-to-Low)	A	B	Push-Pull	-40°C to 85°C	3.9		3.7		4.2		5.2	ns			
					-40°C to 125°C	4		3.9		4.5	5.6					
				Open-Drain	-40°C to 85°C	3.9		4		4.7	6					
					-40°C to 125°C	4		4.3		5	6.4					
$t_{PLH}$	Propagation Delay (Low-to-High)	A	B	Push-Pull	-40°C to 85°C	8.9		6.5		5.8		5.7				
					-40°C to 125°C	9.1		6.8		6.2	6					
				Open-Drain	-40°C to 85°C	22.2		24.4		22.8	18.8					
					-40°C to 125°C	12.5		10.7		10.5	10.4					
$t_{PHL}$	Propagation Delay (Hight-to-Low)	B	A	Push-Pull	-40°C to 85°C	2.9		2.8		3.2		4.2				
					-40°C to 125°C	3		2.9		3.3	4.3					
				Open-Drain	-40°C to 85°C	2.9		2.9		3.4	4.5					
					-40°C to 125°C	3		3.1		3.5	4.7					
$t_{PLH}$	Propagation Delay (Low-to-High)	B	A	Push-Pull	-40°C to 85°C	8.2		1		1		1				
					-40°C to 125°C	1.8		1		0.3	1					
				Open-Drain	-40°C to 85°C	1.5		1		1	1					
					-40°C to 125°C	4		1		1	1					
$t_{en}$	Enable Time	OE	A or B		-40°C to 85°C	250		150		150		100				
					-40°C to 125°C	250		200		200	100					
$t_{dis}$	Disable Time	OE	A or B		-40°C to 85°C	250		200		250		200				
					-40°C to 125°C	250		200		250	160					
$t_{rA}$	Ouput Rise Time	B	A	Push-Pull	-40°C to 85°C	12.2		9		7.3		6.7				
					-40°C to 125°C	12.5		9.5		7.9	7					
				Open-Drain	-40°C to 85°C	190		141.5		112.5	81.5					
					-40°C to 125°C	166.3		130		102.1	73.7					
$t_{rB}$	Ouput Rise Time	A	B	Push-Pull	-40°C to 85°C	13.7		10.2		8.9		7.8				
					-40°C to 125°C	14.3		10.8		9.4	8.2					
				Open-Drain	-40°C to 85°C	145.5		115.1		85.7	47.5					
					-40°C to 125°C	150		110		79	43.1					
$t_{fA}$	Output Fall Time	B	A	Push-Pull	-40°C to 85°C	3.8		3		2.9		3.1				
					-40°C to 125°C	4		3.3		3.2	3.4					
				Open-Drain	-40°C to 85°C	3.9		3.2		3.2	3.5					
					-40°C to 125°C	4.1		3.5		3.5	3.8					

PARAMETER	FROM	TO	Test Conditions		B-Port Supply Voltage (V <sub>CCB</sub> )										UNIT			
					1.8 ± 0.15V			2.5 ± 0.2V			3.3 ± 0.3V			5.0 ± 0.5V				
					MIN	TYP	MAX	MIN	TYP	MAX	MIN	TYP	MAX	MIN		TYP	MAX	
t <sub>B</sub>	Output Fall Time	A	B	Push-Pull	-40°C to 85°C	6.7			6.3			7.1			9.3			ns
					-40°C to 125°C	7			6.9			7.8			10			
				Open-Drain	-40°C to 85°C	6.8			6.8			8			10.7			
					-40°C to 125°C	7.2			7.5			8.8			11.5			

### 5.9 Switching Characteristics, V<sub>CCA</sub> = 1.8 ± 0.15V

PARAMETER	FROM	TO	Test Conditions		B-Port Supply Voltage (V <sub>CCB</sub> )										UNIT			
					1.8 ± 0.15V			2.5 ± 0.2V			3.3 ± 0.3V			5.0 ± 0.5V				
					MIN	TYP	MAX	MIN	TYP	MAX	MIN	TYP	MAX	MIN		TYP	MAX	
t <sub>PHL</sub>	Propagation Delay (High-to-Low)	A	B	Push-Pull	-40°C to 85°C	4.6			4.6			4.7			5.8			ns
t <sub>PHL</sub>		A	B	Push-Pull	-40°C to 125°C	6			6			5.8			5.8			
t <sub>PHL</sub>		A	B	Open-Drain	-40°C to 85°C	8.8			8.8			9.6			10			
t <sub>PHL</sub>		A	B	Open-Drain	-40°C to 125°C	8.8			8.8			9.6			10			
t <sub>PLH</sub>	Propagation Delay (Low-to-High)	A	B	Push-Pull	-40°C to 85°C	7.8			6.8			6.8			7			ns
t <sub>PLH</sub>		A	B	Push-Pull	-40°C to 125°C	8			7.7			6.8			7			
t <sub>PLH</sub>		A	B	Open-Drain	-40°C to 85°C	260			260			208			198			
t <sub>PLH</sub>		A	B	Open-Drain	-40°C to 125°C	50			50			26			33			
t <sub>PHL</sub>	Propagation Delay (High-to-Low)	B	A	Push-Pull	-40°C to 85°C	4.4			4.4			4.5			4.7			ns
t <sub>PHL</sub>		B	A	Push-Pull	-40°C to 125°C	4.4			4.4			4.5			4.7			
t <sub>PHL</sub>		B	A	Open-Drain	-40°C to 85°C	5.3			5.3			4.4			4.1			
t <sub>PHL</sub>		B	A	Open-Drain	-40°C to 125°C	5.3			5.3			4.4			4.5			
t <sub>PLH</sub>	Propagation Delay (Low-to-High)	B	A	Push-Pull	-40°C to 85°C	7.4			5.3			4.5			4.7			ns
t <sub>PLH</sub>		B	A	Push-Pull	-40°C to 125°C	5.3			5.3			4.5			4.7			
t <sub>PLH</sub>		B	A	Open-Drain	-40°C to 85°C	175			175			140			102			
t <sub>PLH</sub>		B	A	Open-Drain	-40°C to 125°C	36			36			16			20			
t <sub>en</sub>	Enable Time	OE	A or B		-40°C to 85°C	250			200			200			200			ns
					-40°C to 125°C	200			200			200			200			
t <sub>dis</sub>	Disable Time	OE	A or B		-40°C to 85°C	250			200			200			200			ns
					-40°C to 125°C	250			200			250			200			
t <sub>rA</sub>	Output Rise Time	B	A	Push-Pull	-40°C to 85°C	11.1			9.5			9.3			7.6			ns
		B	A	Push-Pull	-40°C to 125°C	11.4			9.5			9.3			15			
		B	A	Open-Drain	-40°C to 85°C	165			165			132			95			
		B	A	Open-Drain	-40°C to 125°C	199			199			150			109			
	Output Rise Time	A	B	Push-Pull	-40°C to 85°C	12.8			10.8			9.1			7.6			ns
		A	B	Push-Pull	-40°C to 125°C	13.3			10.8			9.1			7.6			
		A	B	Open-Drain	-40°C to 85°C	152			145			106			58			
		A	B	Open-Drain	-40°C to 125°C	186			186			112			58			

PARAMETER	FROM	TO	Test Conditions		B-Port Supply Voltage (V <sub>CCB</sub> )												UNIT	
					1.8 ± 0.15V			2.5 ± 0.2V			3.3 ± 0.3V			5.0 ± 0.5V				
					MIN	TYP	MAX	MIN	TYP	MAX	MIN	TYP	MAX	MIN	TYP	MAX		
t <sub>FA</sub>	Output Fall Time	B	A	Push-Pull	-40°C to 85°C			5.9			5.9			6			13.3	ns
		B	A	Push-Pull	-40°C to 125°C			5.9			5.9			6			13.3	
		B	A	Open-Drain	-40°C to 85°C			6.9			6.9			6.4			6.1	
		B	A	Open-Drain	-40°C to 125°C			6.9			6.9			6.4			6.1	
	Output Fall Time	A	B	Push-Pull	-40°C to 85°C			7.6			7.6			7.5			8.8	ns
		A	B	Push-Pull	-40°C to 125°C			7.6			7.6			7.5			8.8	
		A	B	Open-Drain	-40°C to 85°C			13.8			13.8			16.2			16.2	
		A	B	Open-Drain	-40°C to 125°C			13.8			13.8			16.2			16.2	

### 5.10 Switching Characteristics, V<sub>CCA</sub> = 2.5 ± 0.2V

PARAMETER	FROM	TO	Test Conditions		B-Port Supply Voltage (V <sub>CCB</sub> )												UNIT				
					1.8 ± 0.15V			2.5 ± 0.2V			3.3 ± 0.3V			5.0 ± 0.5V							
					MIN	TYP	MAX	MIN	TYP	MAX	MIN	TYP	MAX	MIN	TYP	MAX					
t <sub>PHL</sub>	Propagation Delay (High-to-Low)	A	B	Push-Pull	-40°C to 85°C			3.2			3.2			3.3			3.4	ns			
					-40°C to 125°C			3.2			3.2			3.3			3.4				
				Open-Drain	-40°C to 85°C			6.3			6.3			6			5.8				5.8
					-40°C to 125°C			6.3			6.3			6			5.8				5.8
t <sub>PLH</sub>	Propagation Delay (Low-to-High)	A	B	Push-Pull	-40°C to 85°C			3.5			3.5			4.1			4.4	ns			
					-40°C to 125°C			3.8			3.8			4.1			4.4				
				Open-Drain	-40°C to 85°C			250			250			206			190				190
					-40°C to 125°C			3.5			3.5			4.1			4.4				4.4
t <sub>PHL</sub>	Propagation Delay (High-to-Low)	B	A	Push-Pull	-40°C to 85°C			3			3			3.6			4.3	ns			
					-40°C to 125°C			3			3			3.6			4.3				
				Open-Drain	-40°C to 85°C			4.7			4.7			4.2			4				4
					-40°C to 125°C			4.7			4.7			4.2			4				4
t <sub>PLH</sub>	Propagation Delay (Low-to-High)	B	A	Push-Pull	-40°C to 85°C			8.4			2.5			1.6			0.7	ns			
					-40°C to 125°C			8.7			2.5			1.6			0.7				
				Open-Drain	-40°C to 85°C			170			170			140			103				103
					-40°C to 125°C			29.9			2.5			1.6			1				1
t <sub>en</sub>	Enable Time	OE	A or B		-40°C to 85°C			200			200			200			200	ns			
					-40°C to 125°C			200			200			200			200				
t <sub>dis</sub>	Disable Time	OE	A or B		-40°C to 85°C			200			200			200			200	ns			
					-40°C to 125°C			250			200			200			200				
t <sub>FA</sub>	Output Rise Time	B	A	Push-Pull	-40°C to 85°C			10.3			7.4			6.6			5.6	ns			
					-40°C to 125°C			10.6			7.4			6.6			5.6				
				Open-Drain	-40°C to 85°C			153			149			121			89				89
					-40°C to 125°C			180			180			150			105				105

PARAMETER		FROM	TO	Test Conditions		B-Port Supply Voltage (V <sub>CCB</sub> )												UNIT
						1.8 ± 0.15V			2.5 ± 0.2V			3.3 ± 0.3V			5.0 ± 0.5V			
						MIN	TYP	MAX	MIN	TYP	MAX	MIN	TYP	MAX	MIN	TYP	MAX	
t <sub>rB</sub>	Output Rise Time	A	B	Push-Pull	-40°C to 85°C	11.4			8.3			7.2			6.1			ns
					-40°C to 125°C	11.9			8.8			7.6			6.6			
				Open-Drain	-40°C to 85°C	155			151			112			64			
					-40°C to 125°C	170			170			120			64			
t <sub>fA</sub>	Output Fall Time	B	A	Push-Pull	-40°C to 85°C	5.7			5.7			5.5			5.3			ns
					-40°C to 125°C	5.7			5.7			5.5			5.3			
				Open-Drain	-40°C to 85°C	6.9			6.9			6.2			5.8			
					-40°C to 125°C	5.8			5.8			5.8			5.8			
t <sub>fB</sub>	Output Fall Time	A	B	Push-Pull	-40°C to 85°C	7.8			7.8			6.7			6.6			ns
					-40°C to 125°C	7.8			7.8			6.7			6.6			
				Open-Drain	-40°C to 85°C	8.8			8.8			9.4			10.4			
					-40°C to 125°C	8.8			8.8			9.4			10.4			

### 5.11 Switching Characteristics, V<sub>CCA</sub> = 3.3 ± 0.3V

PARAMETER		FROM	TO	Test Conditions		B-Port Supply Voltage (V <sub>CCB</sub> )												UNIT
						1.8 ± 0.15V			2.5 ± 0.2V			3.3 ± 0.3V			5.0 ± 0.5V			
						MIN	TYP	MAX	MIN	TYP	MAX	MIN	TYP	MAX	MIN	TYP	MAX	
t <sub>PHL</sub>	Propagation Delay (High-to-Low)	A	B	Push-Pull	-40°C to 85°C	3.5			2.8			2.4			3.1			ns
					-40°C to 125°C	3.5			2.8			2.4			3.1			
				Open-Drain	-40°C to 85°C	4.2			4.2			4.2			4.6			
					-40°C to 125°C	4.2			4.2			4.2			4.6			
t <sub>PLH</sub>	Propagation Delay (Low-to-High)	A	B	Push-Pull	-40°C to 85°C	4.2			4.2			4.2			4.4			ns
					-40°C to 125°C	4.2			4.2			4.2			4.4			
				Open-Drain	-40°C to 85°C	4.2			4.2			204			165			
					-40°C to 125°C	4.2			4.2			4.2			4.4			
t <sub>PHL</sub>	Propagation Delay (High-to-Low)	B	A	Push-Pull	-40°C to 85°C	2.9			2.5			2.5			3.3			ns
					-40°C to 125°C	2.9			2.5			2.5			3.3			
				Open-Drain	-40°C to 85°C	124			124			124			97			
					-40°C to 125°C	124			124			124			97			
t <sub>PLH</sub>	Propagation Delay (Low-to-High)	B	A	Push-Pull	-40°C to 85°C	10			5			2.5			2.6			ns
					-40°C to 125°C	10			5			2.5			2.6			
				Open-Drain	-40°C to 85°C	27.5			15			139			105			
					-40°C to 125°C	27.5			15			2.5			3.3			
t <sub>en</sub>	Enable Time	OE	A or B		-40°C to 85°C	200			200			200			200			ns
					-40°C to 125°C	200			200			200			200			
t <sub>dis</sub>	Disable Time	OE	A or B		-40°C to 85°C	250			200			250			200			ns
					-40°C to 125°C	250			200			250			200			

PARAMETER		FROM	TO	Test Conditions		B-Port Supply Voltage (V <sub>CCB</sub> )												UNIT
						1.8 ± 0.15V			2.5 ± 0.2V			3.3 ± 0.3V			5.0 ± 0.5V			
						MIN	TYP	MAX	MIN	TYP	MAX	MIN	TYP	MAX	MIN	TYP	MAX	
t <sub>rA</sub>	Output Rise Time	B	A	Push-Pull	-40°C to 85°C			11.6			6.9			5.6			4.8	ns
					-40°C to 125°C			11.6			6.9			5.8			5	
				Open-Drain	-40°C to 85°C			140			140			116			85	
					-40°C to 125°C			140			140			140			102	
t <sub>rB</sub>	Output Rise Time	A	B	Push-Pull	-40°C to 85°C			11.3			8.1			6.4			7.4	ns
					-40°C to 125°C			11.3			8.1			6.8			7.4	
				Open-Drain	-40°C to 85°C			135			130			116			116	
					-40°C to 125°C			135			130			130			75	
t <sub>fA</sub>	Output Fall Time	B	A	Push-Pull	-40°C to 85°C			5.4			5.4			5.4			5	ns
					-40°C to 125°C			5.4			5.4			5.4			5	
				Open-Drain	-40°C to 85°C			6.1			6.1			6.1			5.7	
					-40°C to 125°C			6.1			6.1			6.1			5.7	
t <sub>fB</sub>	Output Fall Time	A	B	Push-Pull	-40°C to 85°C			7.4			7.4			7.4			7.6	ns
					-40°C to 125°C			7.4			7.4			7.4			7.6	
				Open-Drain	-40°C to 85°C			7.6			7.6			7.6			8.3	
					-40°C to 125°C			7.6			7.6			7.6			8.3	

### 5.12 Switching Characteristics: $T_{sk}$ , $T_{MAX}$

over operating free-air temperature range (unless otherwise noted)

PARAMETER	TEST CONDITIONS		$V_{CCA}$	$V_{CCB}$	Operating free-air temperature ( $T_A$ )			UNIT
					-40°C to 125°C			
					MIN	TYP	MAX	
TMAX - Maximum Data Rate	50% Duty Cycle Input One channel switching	Push-Pull Driving	1.2V ± 0.1V	1.8 ± 0.15V			24	Mbps
				2.5V ± 0.2V			24	
				3.3V ± 0.3V			24	
				5V ± 0.5V			24	
			1.5V ± 0.1V	1.8 ± 0.15V			24	
				2.5V ± 0.2V			24	
				3.3V ± 0.3V			24	
				5V ± 0.5V			24	
			1.8 ± 0.15V	1.8 ± 0.15V			50	
				2.5V ± 0.2V			50	
				3.3V ± 0.3V			50	
				5V ± 0.5V			50	
			2.5V ± 0.2V	1.8 ± 0.15V			50	
				2.5V ± 0.2V			50	
				3.3V ± 0.3V			50	
				5V ± 0.5V			50	
			3.3V ± 0.3V	1.8 ± 0.15V			50	
				2.5V ± 0.2V			50	
				3.3V ± 0.3V			50	
				5V ± 0.5V			50	

over operating free-air temperature range (unless otherwise noted)

PARAMETER	TEST CONDITIONS		V <sub>CCA</sub>	V <sub>CCB</sub>	Operating free-air temperature (T <sub>A</sub> )			UNIT
					-40°C to 125°C			
					MIN	TYP	MAX	
TMAX - Maximum Data Rate	50% Duty Cycle InputOne channel switching	Open-Drain Driving	1.2V ± 0.1V	1.8 ± 0.15V			1	Mbps
				2.5V ± 0.2V			1	
				3.3V ± 0.3V			1	
				5V ± 0.5V			1	
			1.5V ± 0.1V	1.8 ± 0.15V			2	
				2.5V ± 0.2V			2	
				3.3V ± 0.3V			2	
				5V ± 0.5V			2	
			1.8 ± 0.15V	1.8 ± 0.15V			2	
				2.5V ± 0.2V			2	
				3.3V ± 0.3V			2	
				5V ± 0.5V			2	
			2.5V ± 0.2V	1.8 ± 0.15V			2	
				2.5V ± 0.2V			2	
				3.3V ± 0.3V			2	
				5V ± 0.5V			2	
3.3V ± 0.3V	1.8 ± 0.15V			2				
	2.5V ± 0.2V			2				
	3.3V ± 0.3V			2				
	5V ± 0.5V			2				
t <sub>w</sub>	Pulse Duration, Data Inputs	Push-Pull Driving	1.2V ± 0.1V to 3.3V ± 0.3V	1.8V ± 0.15V to 5.5V ± 0.5V	41		ns	
		Open-Drain Driving	1.2V ± 0.1V to 3.3V ± 0.3V	1.8V ± 0.15V to 5.5V ± 0.5V	500			
t <sub>sk</sub> - Output skew	Skew between any two outputs of the same package switching in the same direction	Push-Pull Driving	1.2V ± 0.1V to 3.3V ± 0.3V	1.8V ± 0.15V to 5.5V ± 0.5V		1	ns	
		Open-Drain Driving	1.2V ± 0.1V to 3.3V ± 0.3V	1.8V ± 0.15V to 5.5V ± 0.5V		1		

### 5.13 Typical Characteristics

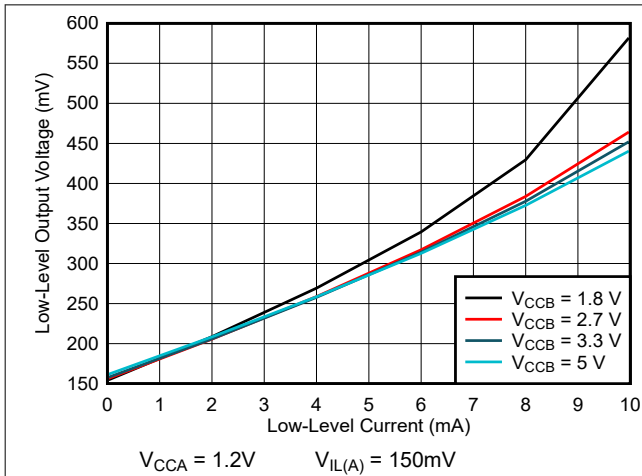

**Figure 5-1. Low-Level Output Voltage ( $V_{OL(Ax)}$ ) vs Low-Level Current ( $I_{OL(Ax)}$ )**

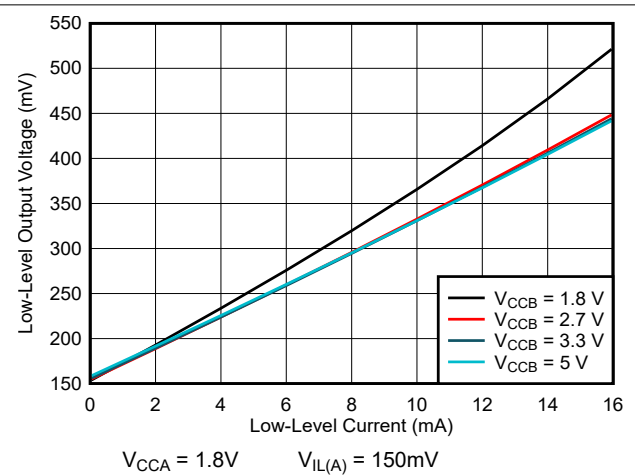

**Figure 5-2. Low-Level Output Voltage ( $V_{OL(Ax)}$ ) vs Low-Level Current ( $I_{OL(Ax)}$ )**

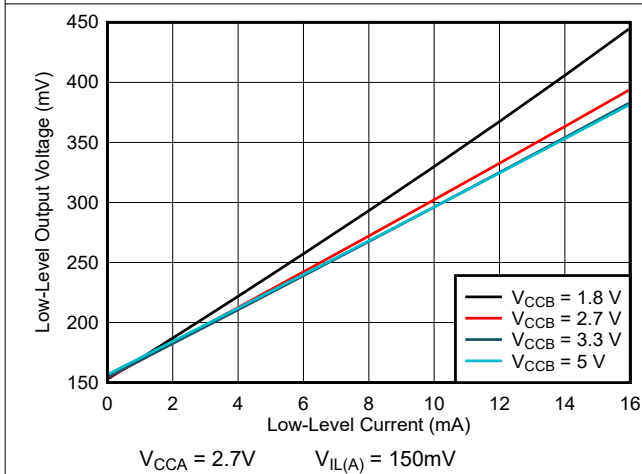

**Figure 5-3. Low-Level Output Voltage ( $V_{OL(Ax)}$ ) vs Low-Level Current ( $I_{OL(Ax)}$ )**

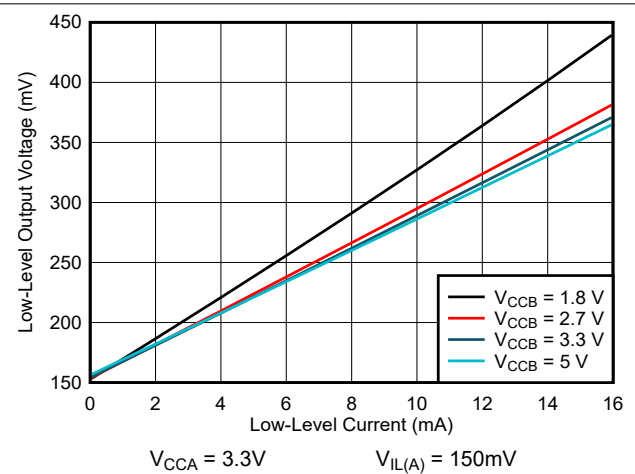

**Figure 5-4. Low-Level Output Voltage ( $V_{OL(Ax)}$ ) vs Low-Level Current ( $I_{OL(Ax)}$ )**

## 6 Parameter Measurement Information

### 6.1 Load Circuits

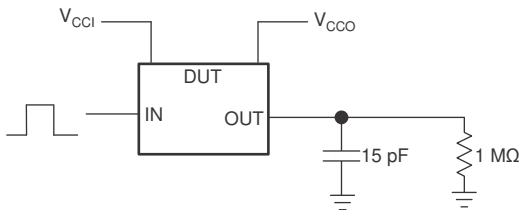

**Figure 6-1. Data Rate, Pulse Duration, Propagation Delay, Output Rise-Time and Fall-Time Measurement Using a Push-Pull Driver**

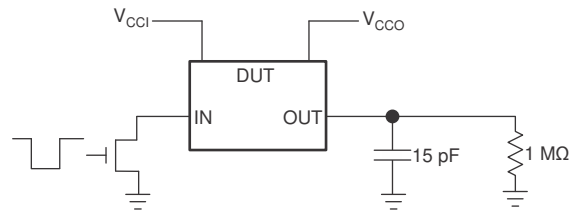

**Figure 6-2. Data Rate, Pulse Duration, Propagation Delay, Output Rise-Time and Fall-Time Measurement Using an Open-Drain Driver**

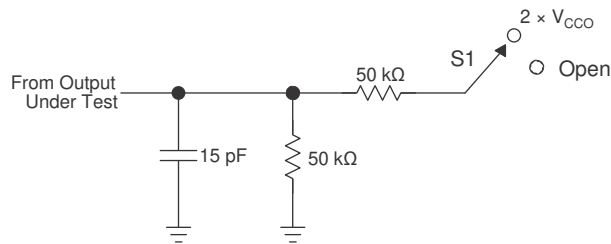

TEST	S1
$t_{PZL} / t_{PLZ}$ ( $t_{dis}$ )	$2 \times V_{CCO}$
$t_{PHZ} / t_{PZH}$ ( $t_{en}$ )	Open

**Figure 6-3. Load Circuit for Enable-Time and Disable-Time Measurement**

1.  $t_{PZL}$  and  $t_{PHZ}$  are the same as  $t_{dis}$ .
2.  $t_{PZL}$  and  $t_{PZH}$  are the same as  $t_{en}$ .
3.  $V_{CCI}$  is the  $V_{CC}$  associated with the input port.
4.  $V_{CCO}$  is the  $V_{CC}$  associated with the output port.

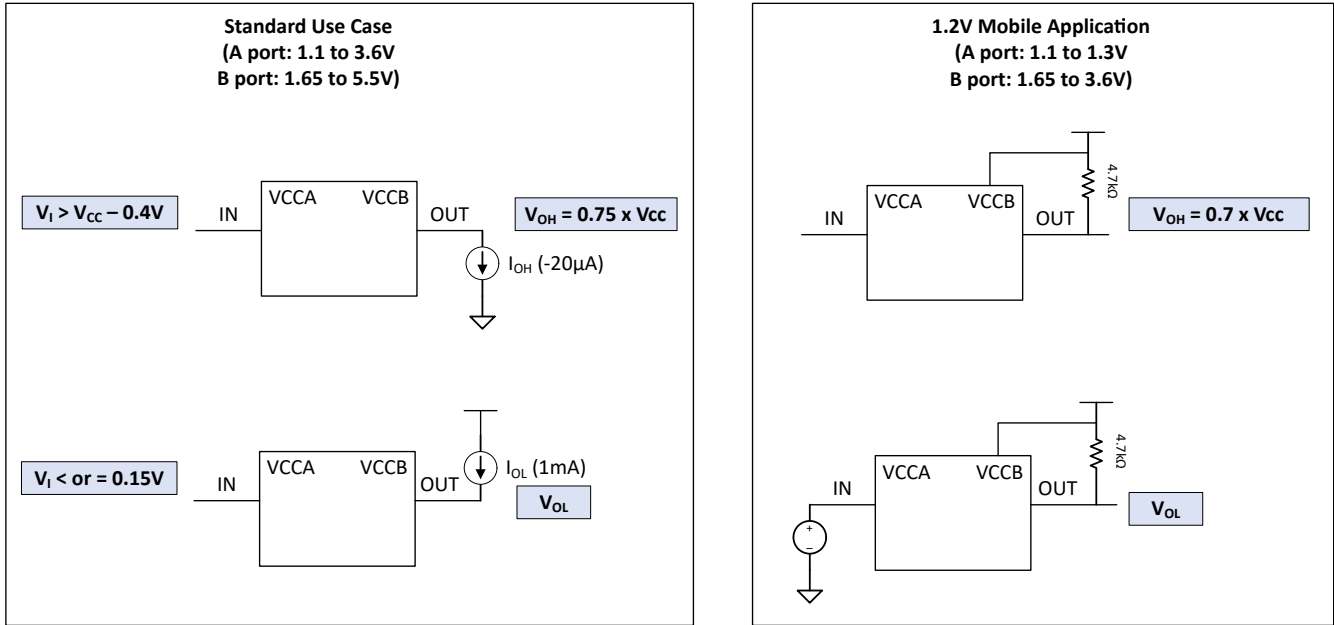

**Note**

For 1.2V Mobile Application, see VIH and VIL test conditions in Section 5.5

**Figure 6-4. Load Circuit Diagram for VOH and VOL**

## 6.2 Voltage Waveforms

The outputs are measured one at a time, with one transition per measurement. All input pulses are supplied by generators that have the following characteristics:

- $PRR \leq 10\text{MHz}$
- $Z_O = 50\Omega$
- $dv/dt \geq 1\text{V/ns}$

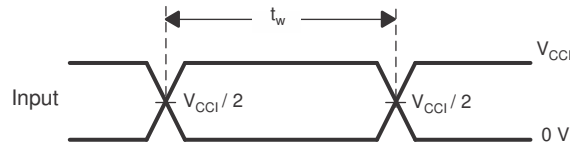

**Figure 6-5. Pulse Duration**

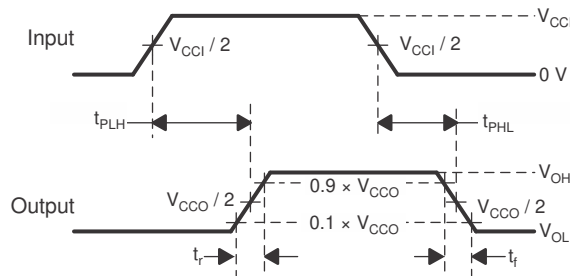

**Figure 6-6. Propagation Delay Times**

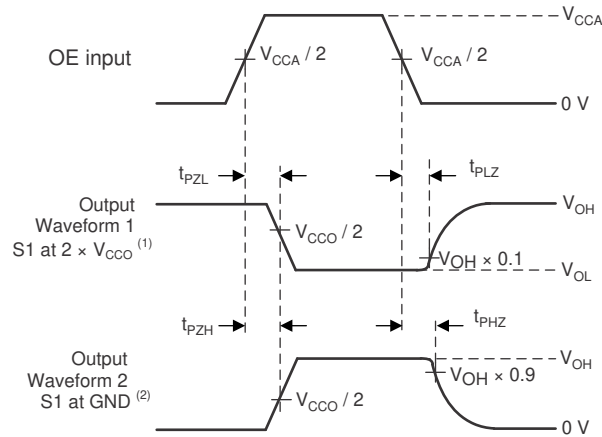

- A. Waveform 1 is for an output with internal such that the output is high, except when OE is high (see [Figure 6-3](#)).
- B. Waveform 2 is for an output with conditions such that the output is low, except when OE is high.

**Figure 6-7. Enable and Disable Times**

## 7 Detailed Description

### 7.1 Overview

The TXS0204 device is a directionless voltage-level translator specifically designed for translating logic voltage levels. The A port is able to accept I/O voltages ranging from 1.1V to 3.6V, while the B port can accept I/O voltages from 1.65V to 5.5V. The device is a pass gate architecture with edge rate accelerators (one shots) to improve the overall data rate. 10kΩ pullup resistors, commonly used in open drain applications, have been conveniently integrated so that an external resistor is not needed. While this device is designed for open drain applications, the device can also translate push-pull CMOS logic outputs.

### 7.2 Functional Block Diagram

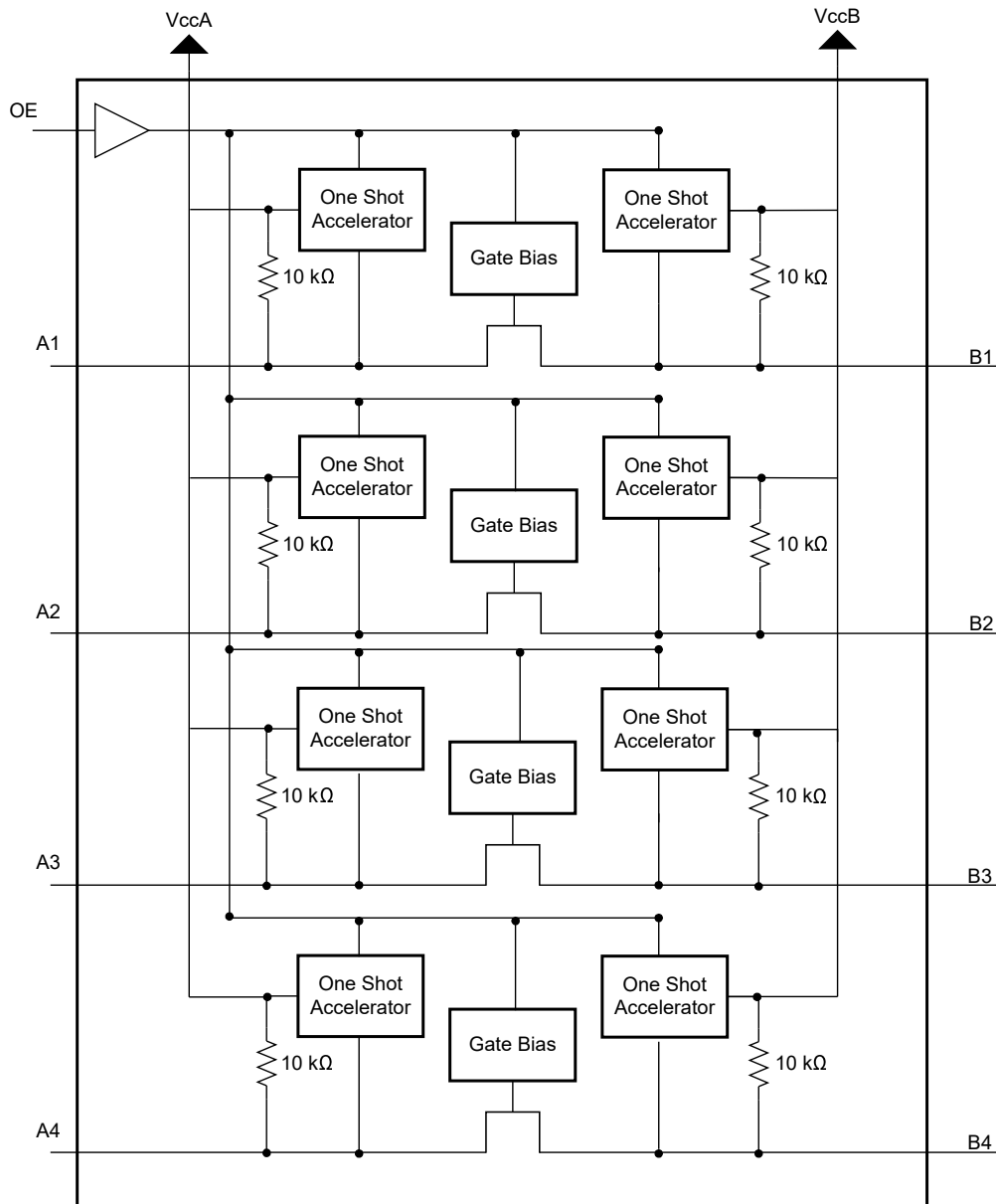

## 7.3 Feature Description

### 7.3.1 Architecture

The TXS0204 architecture (see [Figure 7-1](#)) does not require a direction-control signal to control the direction of data flow from A to B or from B to A.

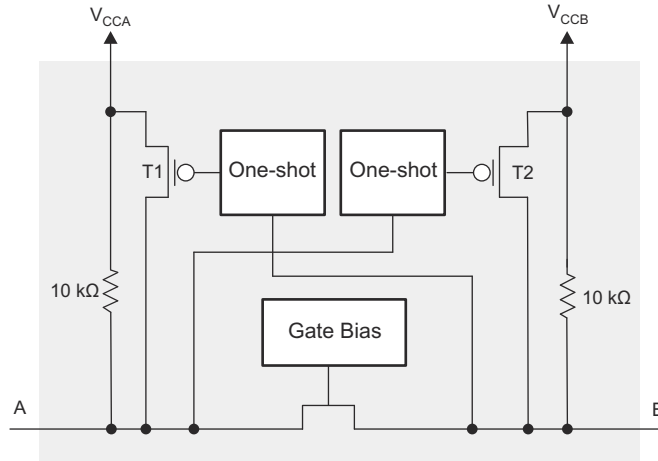

**Figure 7-1. Architecture of a TXS0204 Cell**

Each A-port I/O has an internal 10kΩ pullup resistor to  $V_{CCA}$ , and each B-port I/O has an internal 10kΩ pullup resistor to  $V_{CCB}$ . The output one-shots detect rising edges on the A or B ports. During a rising edge, the one-shot turns on the PMOS transistors (T1, T2) for a short duration which speeds up the low-to-high transition.

### 7.3.2 Input Driver Requirements

The fall time ( $t_{fA}$ ,  $t_{fB}$ ) of a signal depends on the output impedance of the external device driving the data I/Os of the TXS0204 device. Similarly, the  $t_{PHL}$  and maximum data rates also depend on the output impedance of the external driver. The values for  $t_{fA}$ ,  $t_{fB}$ ,  $t_{PHL}$ , and maximum data rates in the data sheet assume that the output impedance of the external driver is less than 50Ω.

### 7.3.3 Power Up

During operation, confirm that  $V_{CCA} \leq V_{CCB}$  at all times. During power-up sequencing,  $V_{CCA} \geq V_{CCB}$  does not damage the device, so any power supply can be ramped up first.

### 7.3.4 Enable and Disable

The TXS0204 device has an OE input that disables the device by setting OE low, which places all I/Os in the high-impedance state. The disable time ( $t_{dis}$ ) indicates the delay between the time when the OE pin goes low and when the outputs actually enter the high-impedance state. The enable time ( $t_{en}$ ) indicates the amount of time the user must allow for the one-shot circuitry to become operational after the OE pin is taken high.

### 7.3.5 Pullup and Pulldown Resistors on I/O Lines

Each A-port I/O has an internal 10kΩ pullup resistor to  $V_{CCA}$ , and each B-port I/O has an internal 10-kΩ pullup resistor to  $V_{CCB}$ . If a smaller value of pullup resistor is required, an external resistor must be added from the I/O to  $V_{CCA}$  or  $V_{CCB}$  (in parallel with the internal 10-kΩ resistors).

## 7.4 Device Functional Modes

The TXS0204 device has two functional modes, enabled and disabled. To disable the device set the OE input low, which places all I/Os in a high impedance state. Setting the OE input high will enable the device.

## 8 Application and Implementation

### Note

Information in the following applications sections is not part of the TI component specification, and TI does not warrant its accuracy or completeness. TI's customers are responsible for determining suitability of components for their purposes, as well as validating and testing their design implementation to confirm system functionality.

### 8.1 Application Information

The TXS0204 device can be used in level-translation applications for interfacing devices or systems operating at different interface voltages with one another. The TXS0204 device is an excellent choice for applications where an open-drain driver is connected to the data I/Os. The TXS0204 device can also be used in applications where a push-pull driver is connected to the data I/Os, but the TXB0104 device can be a better option for such push-pull applications.

### 8.2 Typical Application

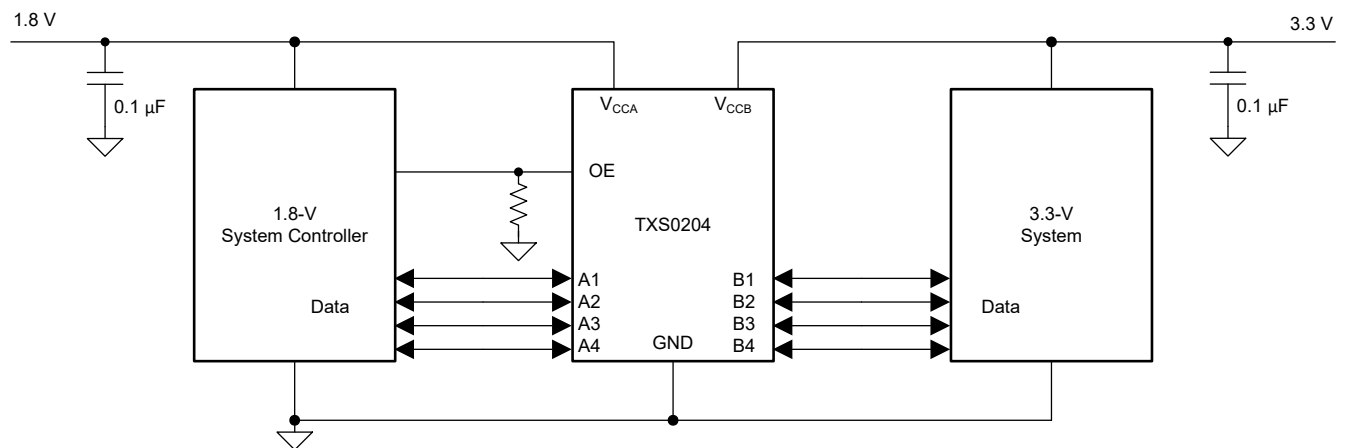

Figure 8-1. Application Schematic

#### 8.2.1 Design Requirements

For this design example, use the parameters listed in [Table 8-1](#).

Table 8-1. Design Parameters

DESIGN PARAMETER	EXAMPLE VALUE
Input voltage range	1.1 to 3.6V
Output voltage range	1.65 to 5.5V

### 8.2.2 Detailed Design Procedure

To begin the design process, determine the following:

- Input voltage range
  - Use the supply voltage of the device that is driving the TXS0204 device to determine the input voltage range. For a valid logic high the value must exceed the  $V_{IH}$  of the input port. For a valid logic low the value must be less than the  $V_{IL}$  of the input port.
- Output voltage range
  - Use the supply voltage of the device that the TXS0204 device is driving to determine the output voltage range.
  - The TXS0204 device has 10-k $\Omega$  internal pullup resistors. External pullup resistors can be added to reduce the total RC of a signal trace if necessary.
- An external pull down resistor decreases the output  $V_{OH}$  and  $V_{OL}$ . Use [Equation 1](#) to calculate the  $V_{OH}$  as a result of an external pull down resistor.

$$V_{OH} = V_{CCx} \times R_{PD} / (R_{PD} + 10\text{ k}\Omega) \tag{1}$$

where

$V_{CCx}$  is the supply voltage on either  $V_{CCA}$  or  $V_{CCB}$   
 $R_{PD}$  is the value of the external pull down resistor

### 8.2.3 Application Curve

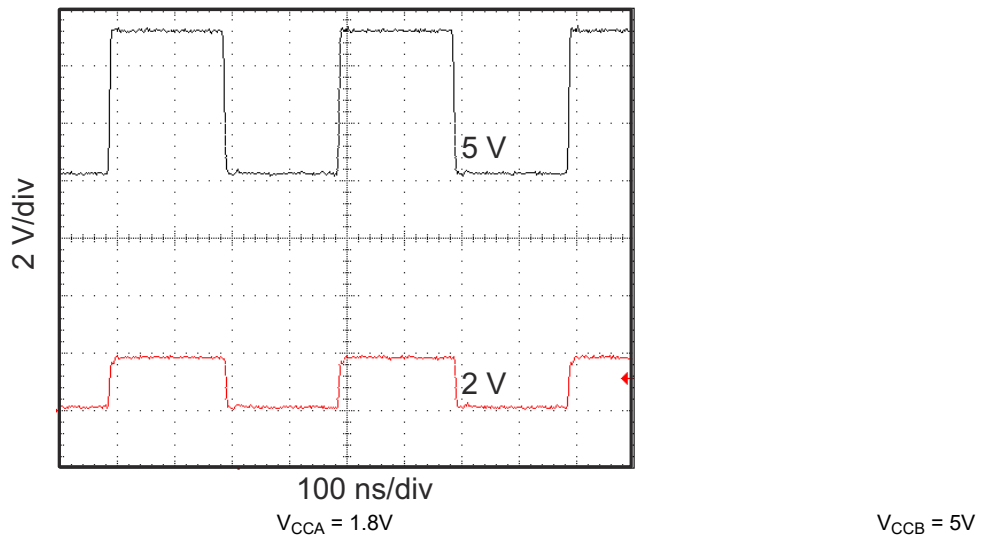

**Figure 8-2. Level-Translation of a 2.5MHz Signal**

## 8.3 Power Supply Recommendations

The TXS0204 device uses two separate configurable power-supply rails,  $V_{CCA}$  and  $V_{CCB}$ .  $V_{CCB}$  accepts any supply voltage from 1.65V to 5.5V and  $V_{CCA}$  accepts any supply voltage from 1.1V to 3.6V as long as  $V_S$  is less than or equal to  $V_{CCB}$ . The A port and B port are designed to track  $V_{CCA}$  and  $V_{CCB}$  respectively allowing for low-voltage bidirectional translation between any of the 1.8V, 2.5V, 3.3V, and 5V voltage nodes.

The TXS0204 device does not require power sequencing between  $V_{CCA}$  and  $V_{CCB}$  during power-up so the power-supply rails can be ramped in any order. A  $V_{CCA}$  value greater than or equal to  $V_{CCB}$  ( $V_{CCA} \geq V_{CCB}$ ) does not damage the device.

The output-enable (OE) input circuit is designed so that it is supplied by  $V_{CCA}$  and when the (OE) input is low, all outputs are placed in the high-impedance state. For the high-impedance state of the outputs during power up or power down, the OE input pin must be tied to GND through a pulldown resistor and must not be enabled until  $V_{CCA}$  and  $V_{CCB}$  are fully ramped and stable. The minimum value of the pulldown resistor to ground is determined by the current-sourcing capability of the driver.

## 8.4 Layout

### 8.4.1 Layout Guidelines

For device reliability, following common printed-circuit board layout guidelines is recommended.

- Bypass capacitors should be used on power supplies.
- Short trace lengths should be used to avoid excessive loading.
- PCB signal trace-lengths must be kept short enough so that the round-trip delay of any reflection is less than the one shot duration, approximately 30ns, and encounters low impedance at the source driver.
- Placing pads on the signal paths for loading capacitors or pullup resistors to help adjust rise and fall times of signals depending on the system requirements

### 8.4.2 Layout Example

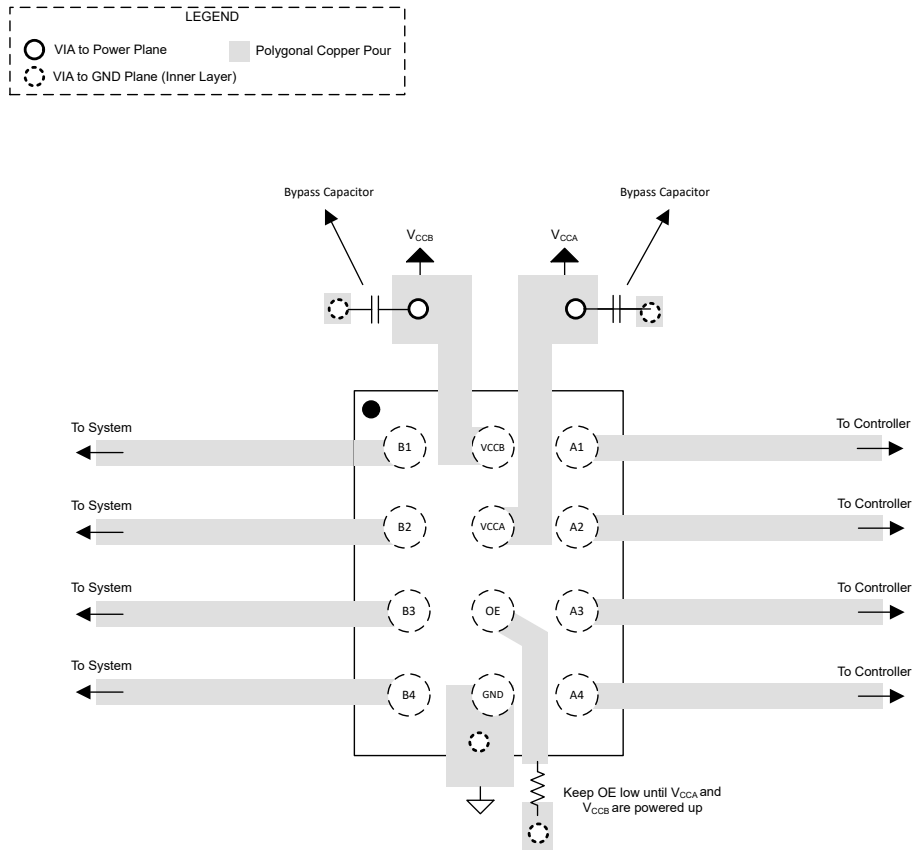

**Figure 8-3. TXS0204 Layout Example**

## 9 Device and Documentation Support

### 9.1 Documentation Support

#### 9.1.1 Related Documentation

For related documentation, see the following:

- Texas Instruments, [Effects of External Pullup and Pulldown Resistors on TXS and TXB Devices application report](#)
- Texas Instruments, [Basics of Voltage Translation application report](#)
- Texas Instruments, [A Guide to Voltage Translation With TXS-Type Translators application report](#)

### 9.2 Receiving Notification of Documentation Updates

To receive notification of documentation updates, navigate to the device product folder on [ti.com](http://ti.com). Click on *Notifications* to register and receive a weekly digest of any product information that has changed. For change details, review the revision history included in any revised document.

### 9.3 Support Resources

[TI E2E™ support forums](#) are an engineer's go-to source for fast, verified answers and design help — straight from the experts. Search existing answers or ask your own question to get the quick design help you need.

Linked content is provided "AS IS" by the respective contributors. They do not constitute TI specifications and do not necessarily reflect TI's views; see TI's [Terms of Use](#).

### 9.4 Trademarks

NanoFree™ and TI E2E™ are trademarks of Texas Instruments. All trademarks are the property of their respective owners.

### 9.5 Electrostatic Discharge Caution



This integrated circuit can be damaged by ESD. Texas Instruments recommends that all integrated circuits be handled with appropriate precautions. Failure to observe proper handling and installation procedures can cause damage.

ESD damage can range from subtle performance degradation to complete device failure. Precision integrated circuits may be more susceptible to damage because very small parametric changes could cause the device not to meet its published specifications.

### 9.6 Glossary

[TI Glossary](#) This glossary lists and explains terms, acronyms, and definitions.

## 10 Revision History

NOTE: Page numbers for previous revisions may differ from page numbers in the current version.

Changes from Revision A (January 2026) to Revision B (March 2026)	Page
• Corrected GPN throughout the datasheet.....	1

Changes from Revision * (February 2025) to Revision A (January 2026)	Page
• First public release of the data sheet.....	1

DATE	REVISION	NOTES
February 2025	*	Initial Release

## 11 Mechanical, Packaging, and Orderable Information

The following pages include mechanical, packaging, and orderable information. This information is the most current data available for the designated devices. This data is subject to change without notice and revision of this document. For browser-based versions of this data sheet, refer to the left-hand navigation.

**PACKAGING INFORMATION**

Orderable part number	Status (1)	Material type (2)	Package   Pins	Package qty   Carrier	RoHS (3)	Lead finish/ Ball material (4)	MSL rating/ Peak reflow (5)	Op temp (°C)	Part marking (6)
<a href="#">TXS0204YCJR</a>	Active	Production	DSBGA (YCJ)   12	12000   LARGE T&R	Yes	SNAGCU	Level-1-260C-UNLIM	-40 to 125	QF

(1) **Status:** For more details on status, see our [product life cycle](#).

(2) **Material type:** When designated, preproduction parts are prototypes/experimental devices, and are not yet approved or released for full production. Testing and final process, including without limitation quality assurance, reliability performance testing, and/or process qualification, may not yet be complete, and this item is subject to further changes or possible discontinuation. If available for ordering, purchases will be subject to an additional waiver at checkout, and are intended for early internal evaluation purposes only. These items are sold without warranties of any kind.

(3) **RoHS values:** Yes, No, RoHS Exempt. See the [TI RoHS Statement](#) for additional information and value definition.

(4) **Lead finish/Ball material:** Parts may have multiple material finish options. Finish options are separated by a vertical ruled line. Lead finish/Ball material values may wrap to two lines if the finish value exceeds the maximum column width.

(5) **MSL rating/Peak reflow:** The moisture sensitivity level ratings and peak solder (reflow) temperatures. In the event that a part has multiple moisture sensitivity ratings, only the lowest level per JEDEC standards is shown. Refer to the shipping label for the actual reflow temperature that will be used to mount the part to the printed circuit board.

(6) **Part marking:** There may be an additional marking, which relates to the logo, the lot trace code information, or the environmental category of the part.

Multiple part markings will be inside parentheses. Only one part marking contained in parentheses and separated by a "-" will appear on a part. If a line is indented then it is a continuation of the previous line and the two combined represent the entire part marking for that device.

**Important Information and Disclaimer:** The information provided on this page represents TI's knowledge and belief as of the date that it is provided. TI bases its knowledge and belief on information provided by third parties, and makes no representation or warranty as to the accuracy of such information. Efforts are underway to better integrate information from third parties. TI has taken and continues to take reasonable steps to provide representative and accurate information but may not have conducted destructive testing or chemical analysis on incoming materials and chemicals. TI and TI suppliers consider certain information to be proprietary, and thus CAS numbers and other limited information may not be available for release.

In no event shall TI's liability arising out of such information exceed the total purchase price of the TI part(s) at issue in this document sold by TI to Customer on an annual basis.

**TAPE AND REEL INFORMATION**

**QUADRANT ASSIGNMENTS FOR PIN 1 ORIENTATION IN TAPE**



\*All dimensions are nominal

Device	Package Type	Package Drawing	Pins	SPQ	Reel Diameter (mm)	Reel Width W1 (mm)	A0 (mm)	B0 (mm)	K0 (mm)	P1 (mm)	W (mm)	Pin1 Quadrant
TXS0204YCJR	DSBGA	YCJ	12	12000	180.0	8.4	1.12	1.62	0.42	2.0	8.0	Q1

**TAPE AND REEL BOX DIMENSIONS**

\*All dimensions are nominal

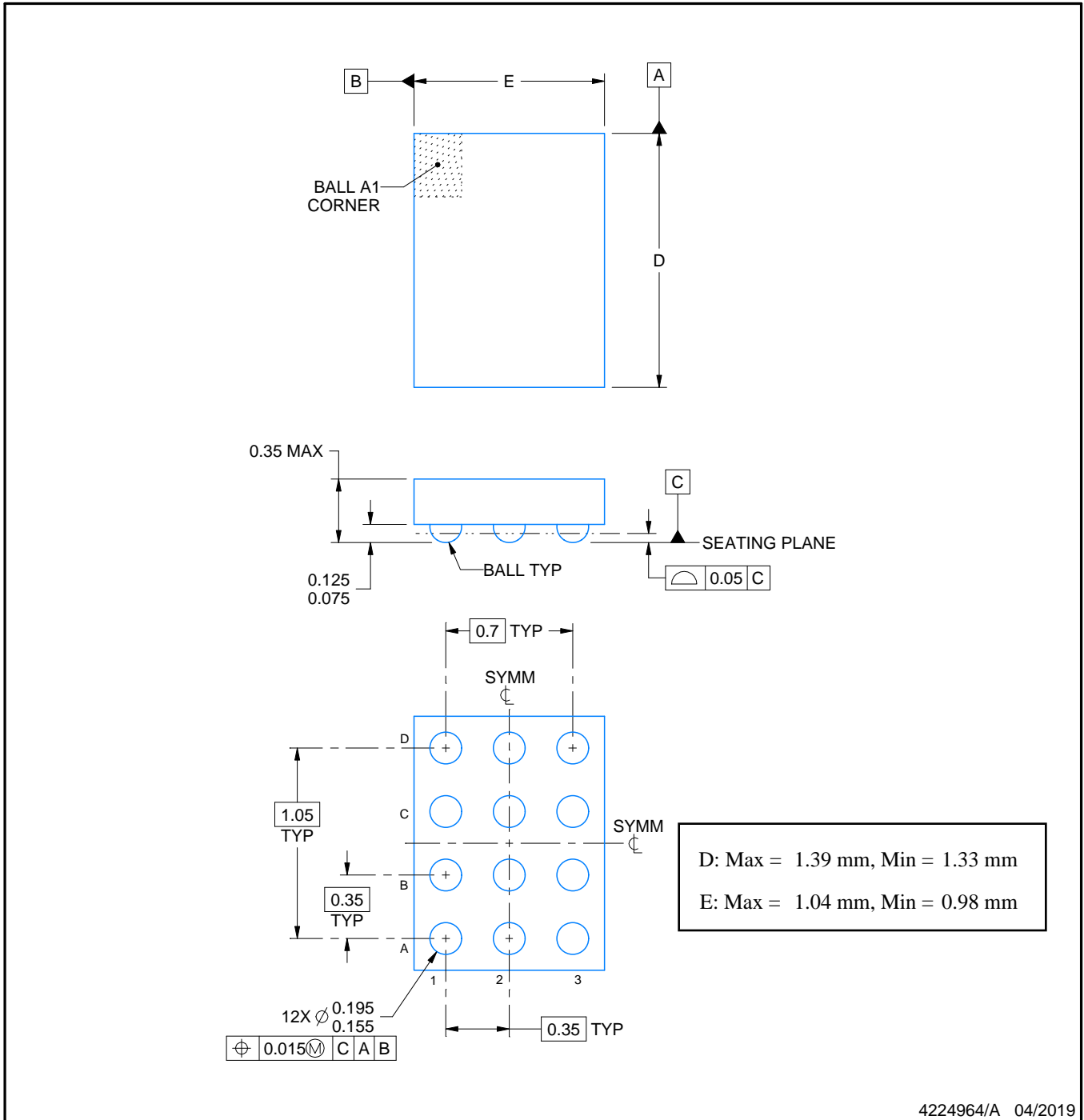
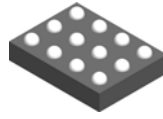
Device	Package Type	Package Drawing	Pins	SPQ	Length (mm)	Width (mm)	Height (mm)
TXS0204YCJR	DSBGA	YCJ	12	12000	182.0	182.0	20.0



NOTES:

1. All linear dimensions are in millimeters. Any dimensions in parenthesis are for reference only. Dimensioning and tolerancing per ASME Y14.5M.
2. This drawing is subject to change without notice.

# EXAMPLE BOARD LAYOUT

YCJ0012

DSBGA - 0.35 mm max height

DIE SIZE BALL GRID ARRAY

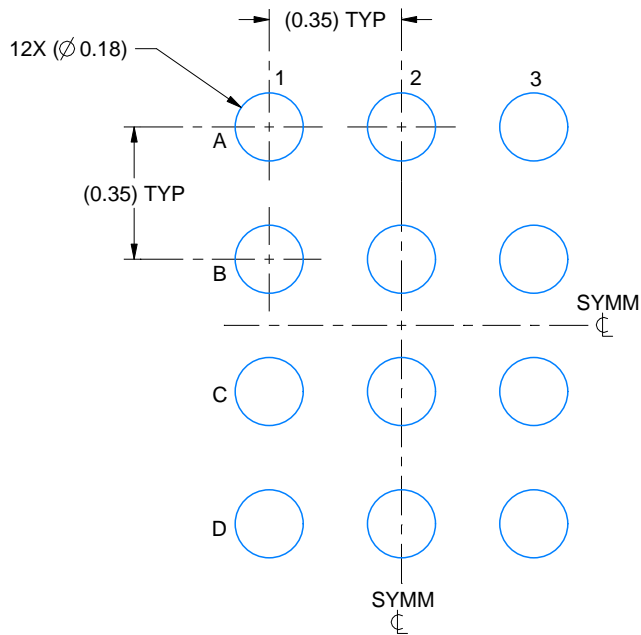

LAND PATTERN EXAMPLE  
EXPOSED METAL SHOWN  
SCALE: 50X

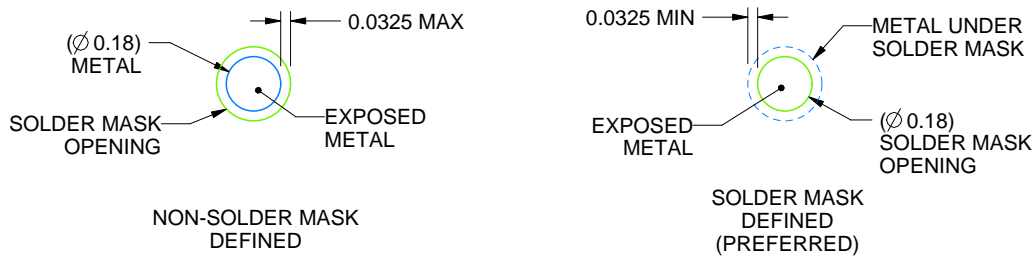

SOLDER MASK DETAILS  
NOT TO SCALE

4224964/A 04/2019

NOTES: (continued)

- 3. Final dimensions may vary due to manufacturing tolerance considerations and also routing constraints. See Texas Instruments Literature No. SNVA009 ([www.ti.com/lit/snva009](http://www.ti.com/lit/snva009)).

# EXAMPLE STENCIL DESIGN

YCJ0012

DSBGA - 0.35 mm max height

DIE SIZE BALL GRID ARRAY

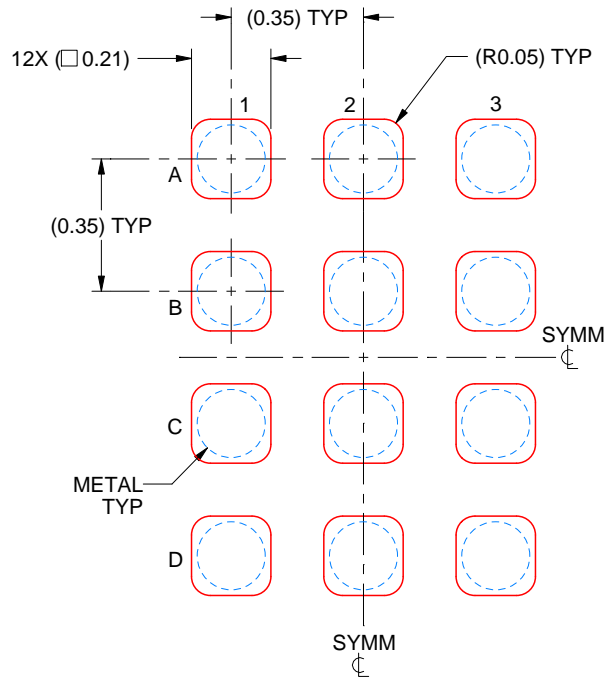

SOLDER PASTE EXAMPLE  
BASED ON 0.075 mm THICK STENCIL  
SCALE: 50X

4224964/A 04/2019

NOTES: (continued)

4. Laser cutting apertures with trapezoidal walls and rounded corners may offer better paste release.

## IMPORTANT NOTICE AND DISCLAIMER

TI PROVIDES TECHNICAL AND RELIABILITY DATA (INCLUDING DATASHEETS), DESIGN RESOURCES (INCLUDING REFERENCE DESIGNS), APPLICATION OR OTHER DESIGN ADVICE, WEB TOOLS, SAFETY INFORMATION, AND OTHER RESOURCES "AS IS" AND WITH ALL FAULTS, AND DISCLAIMS ALL WARRANTIES, EXPRESS AND IMPLIED, INCLUDING WITHOUT LIMITATION ANY IMPLIED WARRANTIES OF MERCHANTABILITY, FITNESS FOR A PARTICULAR PURPOSE OR NON-INFRINGEMENT OF THIRD PARTY INTELLECTUAL PROPERTY RIGHTS.

These resources are intended for skilled developers designing with TI products. You are solely responsible for (1) selecting the appropriate TI products for your application, (2) designing, validating and testing your application, and (3) ensuring your application meets applicable standards, and any other safety, security, regulatory or other requirements.

These resources are subject to change without notice. TI grants you permission to use these resources only for development of an application that uses the TI products described in the resource. Other reproduction and display of these resources is prohibited. No license is granted to any other TI intellectual property right or to any third party intellectual property right. TI disclaims responsibility for, and you fully indemnify TI and its representatives against any claims, damages, costs, losses, and liabilities arising out of your use of these resources.

TI's products are provided subject to [TI's Terms of Sale](#), [TI's General Quality Guidelines](#), or other applicable terms available either on [ti.com](#) or provided in conjunction with such TI products. TI's provision of these resources does not expand or otherwise alter TI's applicable warranties or warranty disclaimers for TI products. Unless TI explicitly designates a product as custom or customer-specified, TI products are standard, catalog, general purpose devices.

TI objects to and rejects any additional or different terms you may propose.

Copyright © 2026, Texas Instruments Incorporated

Last updated 10/2025