

Application Note

CC35xxE Production Guide



ABSTRACT

Texas Instruments provides many resources to assist users in quickly examining the functionality and performance of devices. This document provides the necessary information to guide users in testing and flashing products with the CC35xxE device on the production line.

Table of Contents

1 Introduction	2
1.1 Production Line Overview.....	2
1.2 Production Line Types.....	2
1.3 SimpleLink™ Wi-Fi Toolbox.....	3
2 Hardware Setup on Production Line	4
3 Production Line Test	7
3.1 xSPI Memory Connection Test.....	7
3.2 I/O Open and Shorts Test	7
3.3 RF Tests.....	7
4 Activation and One-Time Programming (OTP)	9
5 Flash Programming	9
6 Summary	10
7 References	10

Trademarks

SimpleLink™ and LaunchPad™ are trademarks of Texas Instruments.

Bluetooth® is a registered trademark of Bluetooth SIG, Inc.

ARM® is a registered trademark of Arm Limited (or its subsidiaries or affiliates) in the US and/or elsewhere.

Mac® is a registered trademark of Apple Inc.

All trademarks are the property of their respective owners.

1 Introduction

1.1 Production Line Overview

Texas Instruments provides several resources that assist manufacturers using the CC35xxE devices to produce products quickly and efficiently. To design products with efficient production, TI provides reference design collateral and application notes for schematic and printed circuit board (PCB) designs. Software and hardware tools are developed for programming and testing the CC35xxE device in the production line.

Depending on the relevant product and type of production line, TI recommends implementing different stages of the production line. This process normally includes stages such as:

- The assembly onboard stage
- The one-time programming (OTP) stage
- The production line test of the inputs and outputs (I/O) stage
- The radio frequency (RF) and eXpanded serial peripheral interface (xSPI) memory connection stage
- The flash programming stage

1.2 Production Line Types

There are three different classifications of production line which this document discusses:

- Integrated circuit (IC) original equipment manufacturer (OEM) production line – Assembles, tests, and delivers a final product with the CC35xxE device, designed for a specific company.
- Module vendor production line – Assembles a certified module with the CC35xxE device inside to be used on other products from different companies.
- Module OEM production line – Assembles the module from a module vendor on a final product.

Figure 1-1 shows the high-level concept for an IC OEM production line. In this case, the production line delivers a full product that is tested and programmed.

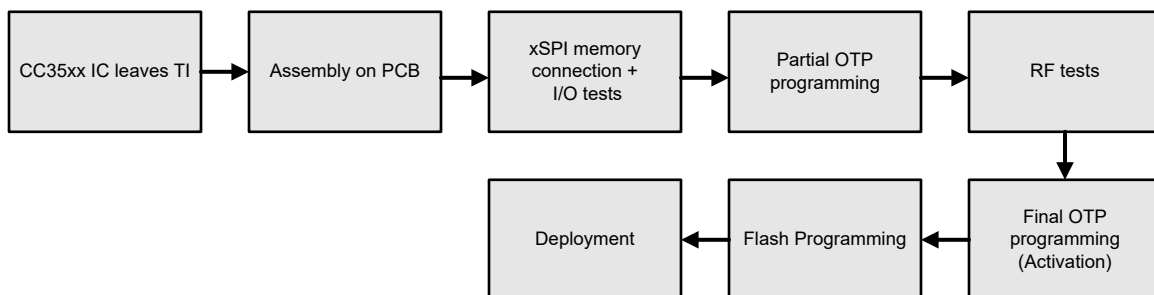

Figure 1-1. OEM Production Line

Figure 1-2 shows the high-level concept for a module vendor production line. Module vendors deliver a product that is assembled with the basic bill of materials (BOM) for the functions of the CC35xxE device, including the RF components and flash. The components that are part of the module are verified by testing flash connectivity and I/O open and shorts (if relevant). RF tests are also performed to verify internal assembly, however, the module OEM must also test RF on the final product to verify assembly of the external power supply (see Section 3.3). Partial OTP programming is an option to module vendors; however, the module must not be activated or flash programmed (see Section 4).

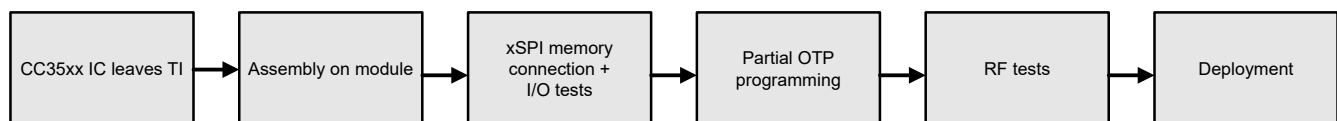

Figure 1-2. Module Vendor Production Line

Figure 1-3 shows the high-level concept for a module OEM production line. In this case, the OEM is assembling a module on the final product; therefore, the internal assembly of the module does not need to be verified through test. Depending on the module, the OEM only needs to test I/O open and shorts, and perform the

final OTP programming with activation and flash programming. RF tests are optional, depending on the module power supply and if there are any external RF components (see [Section 3.3](#)).

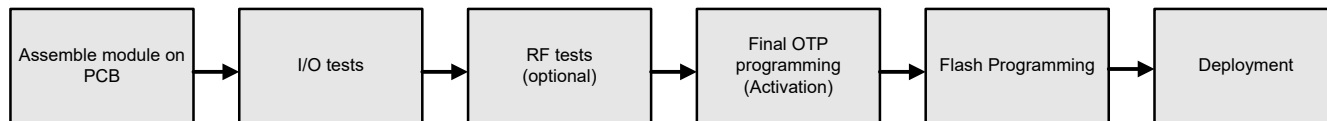

Figure 1-3. Module OEM Production Line

1.3 SimpleLink™ Wi-Fi Toolbox

[SimpleLink Wi-Fi Toolbox](#) must be used to perform the tests and program the CC35xxE device, using a [LP-XDS110ET](#) or [LP-XDS110](#) LaunchPad™ Development Kit to interface. The toolbox application has a web-based graphical user interface (GUI), but the following options for automation on the production line are also available:

- Command line interface (CLI)
- RestAPI commands based on HTTP

Both options give the full range of toolbox capabilities necessary for the production line to users.

CLI is generally more user-friendly and quicker to integrate into a script than RestAPI, however, the command execution takes much longer. RestAPI is generally faster than CLI and easily scalable, however, RestAPI requires software scripts that can execute HTTP commands. For more information and example scripts, please see the [SimpleLink™ Wi-Fi Toolbox](#) documentation.

2 Hardware Setup on Production Line

Programming and radio + I/O testing is done with the SimpleLink™ Wi-Fi Toolbox, which requires access to the serial wire debug (SWD) interface (SWCLK and SWDIO pins) of the CC35xxE device for connection to an XDS110 platform. The supported XDS110 platforms are the [LP-XDS110ET](#) and [LP-XDS110](#) LaunchPad™ Development Kits. The LP-XDS110 also requires a target reference voltage for the (I/O) communication (V_{TREF}); the I/O voltage of the SWD interface is equal to the VIO1 supply pin of the CC35xxE device, therefore, VIO1 must be shorted to V_{TREF} of the XDS110 platform.

When using the LP-XDS110ET LaunchPad™ Development Kit, verifying the jumper on the board (labeled TGT VDD) is in the extension (EXT.) configuration is important, as shown in [Figure 2-1](#). When using the LP-XDS110 LaunchPad™ Development Kit, the V_{TREF} connection must not be to the 20-pin header, but to the middle pin of the target VDD header pin (without the jumper assembled), see [Figure 2-2](#).

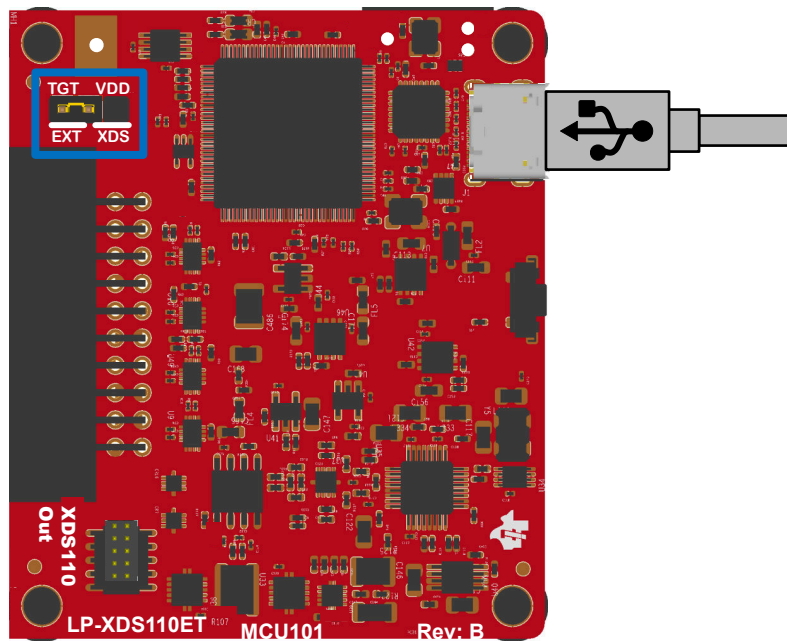

Figure 2-1. LP-XDS110ET LaunchPad™ Development Kit Configuration

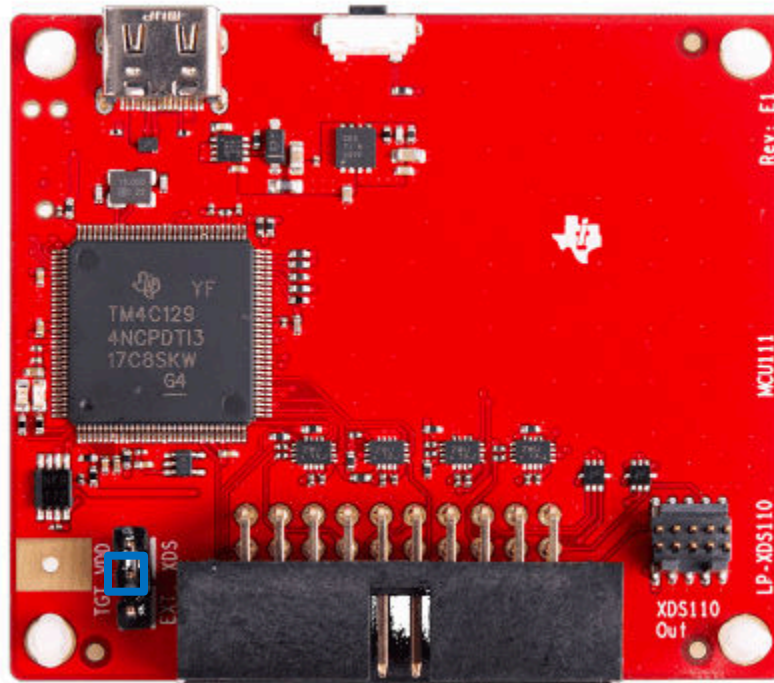

Figure 2-2. LP-XDS110 LaunchPad™ Development Kit Connection

Connecting the nRESET pin of the CC35xxE device to the XDS110 LaunchPad™ Development Kit is required to enable the programmer tool to reset the device during programming. The nRESET pin output of the XDS110 LaunchPad™ Development Kit is open-drain output, therefore an external pullup resistor is needed on the target board.

Supply power to both the LP-XDS110 LaunchPad™ Development Kit and the device separately. The LP-XDS110 LaunchPad™ Development Kit does not provide enough power to support all RF test modes of the CC35xxE device family

Figure 2-3 depicts a high-level setup of a tester on a production line. The XDS110 platform must be the LP-XDS110ET or the LP-XDS110 LaunchPad™ Development Kits. The vector signal analyzer (VSA) or vector signal generator (VSG) is used in the production line test (PLT) of the RF, see Section 3.3 for more information.

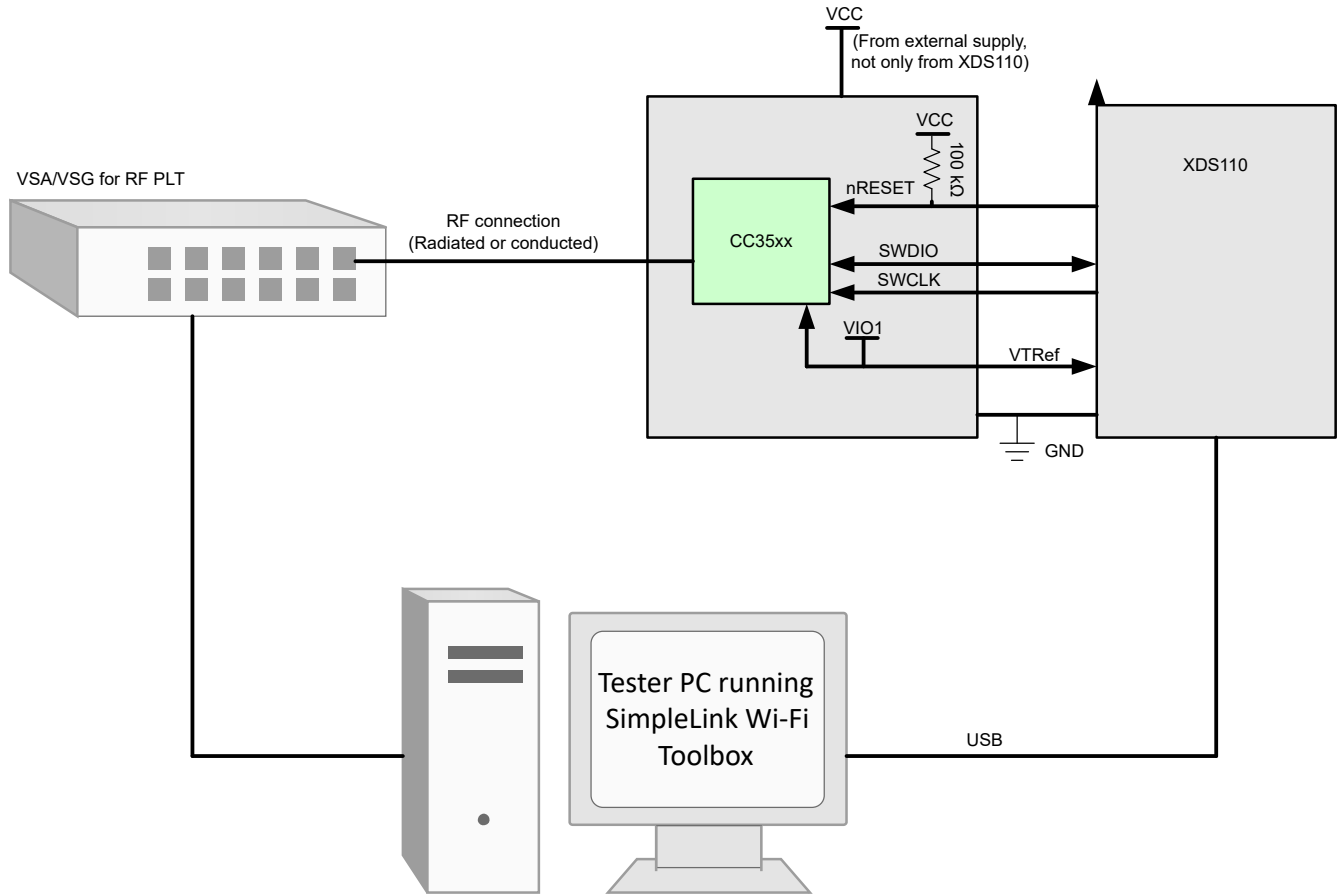

Figure 2-3. Hardware Setup on the Production Line

3 Production Line Test

Testing on the production line is important to verify correct assembly of the CC35xxE device and other external BOM and detect PCB level issues. Using the SimpleLink™ Wi-Fi Toolbox, customers can test the I/O connections, flash connectivity, and RF performance on the production line. Depending on the end-product, customers can decide what to test for each device leaving the production floor, taking into account the tradeoffs between:

- More tests to achieve high confidence in each device assembled.
- Less tests to potentially save time and cost.

TI recommends running the PLT test to find product assembly issues before going through the time-consuming process of activation and flash programming. TI provides a custom firmware (FW) image that can be loaded prior to device activation that is authenticated on the device and run from RAM. Loading any other FW images for the PLT is not possible before device activation on the device as these FW images have not been signed by TI.

3.1 xSPI Memory Connection Test

The CC35xxE device requires an external xSPI flash for execution, connected through a quad serial peripheral interface (QSPI) interface. This high-speed interface (80MHz) and the external flash are critical for proper device function and the application image is programmed into the flash during production. Verifying the assembly of the external flash during the PLT is important. This test is possible using the SimpleLink™ Wi-Fi Toolbox programmer tool.

Note

The flash connectivity test is only possible through the SimpleLink™ Wi-Fi Toolbox **before the device is activated**. Customers must take this fact into account when defining the PLT and determining the order to complete each step on production line.

3.2 I/O Open and Shorts Test

The CC35xxE device has up to 38 I/O pins, where most pins can be used as GPIOs to support a wide variety of external peripherals. Solder issues from assembly or errors related to the PCB can cause certain connections to or from the CC35xxE device to be open or short circuits. TI gives the option to verify the status of the I/Os and proper connectivity in the PLT using the *Radio* tool of the SimpleLink™ Wi-Fi Toolbox. The I/O control provides the following options for all GPIOs:

- Configure to an input or output
- Set the state of the pin to logic high or logic low
- Read the logic level on the pin (high or low)

Note

The flash connectivity test is only possible through the SimpleLink™ Wi-Fi Toolbox **before the device is activated**. Customers must take this into account when defining the PLT and determining the order to complete each step on the production line.

3.3 RF Tests

The main goal of the RF PLT is to catch manufacturing defects in the production line, such as assembly defects, soldering issues, and other problems related to the PCB. The tests performed in the RF PLT verify the connectivity of the external BOM to the CC35xxE device; specifically, the components considered part of the RF external chain. Testing the maximum power of the transmitter (TX) and error vector magnitude (EVM) can test for a successful connection of the external BOM assembly. The BOM must be verified and includes:

- **External power supply, 1.8V and 3.3V:** Covered in the maximum TX power and EVM tests
- **External RF filters, band-pass filters (BPF), and diplexers (dual band designs only):** Covered in the maximum TX power and EVM tests
- **Crystal oscillator (XTAL), fast clock 52MHz:** Covered in the EVM test
- **RF switch for antenna diversity, if used:** Covered in the maximum TX power and EVM tests

The thresholds for passing and failing a device from the RF PLT is based on validation testing of the product before mass production, the datasheet of the CC35xxE device, and the IEEE standards.

Maximum TX Power is according to the datasheet of the CC35xxE device and validation of the product before mass production. The expected values must take into account board and cable losses. The acceptable tolerance of TX power on the production line is based on tests of the product before mass production and customer requirements. Based on TI tests of the CC35xxE device with reference design components, the TX power variance across devices is 1.5dB at room temperature. This variance is potentially higher depending on the PCB or external filters on the customer board. The highest output power (and highest static RF mode current consumption) possible from the CC35xxE device is when transmitting 11b 1DSSS in 2.4GHz and 11a 6OFDM in 5GHz, therefore these are the modes that TI recommends testing.

Error Vector Magnitude (EVM) must meet the IEEE 802.11 specifications. The strictest EVM requirement is when transmitting at the higher physical layer (PHY) rates, -25dB for 11a/g 54OFDM and -27dB for 11n / ax SU MCS7, according to the IEEE specification. TI recommends testing one of these modes in the RF PLT.

3.3.1 Additional Considerations for the RF PLT

A few more notes to take into consideration:

- Testing one channel on each frequency band (2.4GHz and 5GHz) is the minimum number of channels that must be tested.
 - More channels can be added to the RF test to verify performance across the frequency band, as desired.
 - TI recommends testing more channels on the 5GHz band due to the large span of this frequency band when compared to the 2.4GHz band.
- Testing the Bluetooth® Low Energy separately is not a strict requirement.
 - Wireless local area network (WLAN) modulations in the same 2.4GHz frequency band transmit at higher power and have stricter requirements for the EVM.
 - The 2.4GHz WLAN and BLE use the same RF front end, so WLAN tests give a high confidence that BLE also works.
- Testing RX is not a strict requirement.
 - The RX test does not add any more verification that the external BOM is assembled correctly. The TX power and EVM tests cover this verification.
 - RX sensitivity can verify the XTAL and external filters similar to the EVM and TX power tests, however this test takes longer, especially on the production line.
- Conducted and radiated testing are both valid for the RF PLT.
 - Conducted testing is more accurate, provides better shielding from noise, and is easier to calibrate for path loss. However, not all end products support a dedicated RF connector, the antenna is not validated in this case, and manually connecting and reconnecting the conducted test for each device under test (DUT) takes more time during the PLT.
 - Radiated testing is faster on the production floor and easily leveraged across different devices with different antenna types. However, the setup is harder to calibrate for path loss, less accurate, and more sensitive to noise.
- If the CC35xxE device is connected to two antennas for antenna diversity, both RF paths must be tested during the RF PLT. Not every test is required on both antennas, but at least one test on each antenna is required to check for proper functioning of the external RF switch.

The *Radio* tool, which is part of the SimpleLink™ Wi-Fi Toolbox, must be used for the RF PLT. There is a GUI available; however, for an automated test structure, the CLI of the Radio tool using CMD terminal or restAPI commands used within a software script are better options. See the documents of the SimpleLink™ Wi-Fi Toolbox for script examples and parameter explanations.

The following lists an example of the RF PLT test flow which tests two channels on each frequency band:

1. Load the Radio tool on a PC and load FW to device.
2. Tune WLAN Channel 1 (2412MHz) and calibrate.
3. TX test 1DSSS max power, VSA measures TX power from DUT.
4. Tune WLAN Channel 11 (2462MHz) and calibrate.
5. TX test 11n MCS7 max power, VSA measures EVM and TX power from DUT.

6. Tune WLAN Channel 36 (5180MHz) and calibrate.
7. TX test 11a 6OFDM max power, VSA measures EVM and TX power from DUT.
8. Tune WLAN Channel 169 (5845MHz) and calibrate
9. TX test 11n MCS7 max power, VSA measures EVM and TX power from DUT.

4 Activation and One-Time Programming (OTP)

Before the CC35xxE device can be programmed with an application image and enabled in an operational use-case the device must be activated. The activation process programs a root-of-trust (ROT) key to one-time-programming (OTP) bits in the fuse ROM of the CC35xxE device. The hash of this private key is used to authenticate the images programmed into the xSPI flash by matching the private key against the public key of the images. This authentication associates the activated CC35xxE device with the vendor who owns the private key and only accepts image programming requests when the hash matches the ROT key. For more information on this process and the CC35xxE device boot concept, see the [CC35xx SimpleLink™ Wi-Fi 6 and Bluetooth® Low Energy Wireless MCU Technical Reference Manual](#).

See [Table 4-1](#) for the capabilities of the CC35xxE device before and after activation.

Table 4-1. CC35xxE Device Activation

Tool Operation	CC35xxE Before Activation	CC35xxE After Activation
Can use TI Tools using SWD for: <ul style="list-style-type: none"> • I/O Open and Shorts Testing • xSPI Memory Connection Test • Programming Fuses 	Yes	No
RF testing with the Radio tool (SWD Interface)	Yes	Yes
RF testing using customer application code (image running on the ARM® M33)	No	Yes
Loading customer application code image to the xSPI flash using SWD	No	Yes
Debugging customer application code using SWD	No	Options selectable at activation: <ul style="list-style-type: none"> • Set debug disable fuse bit; in which case code debug is locked out permanently • Do not set debug disable fuse bit; in which case code debug can be enabled after booting by signing a unique device value

Activation and initial programming must be done on the production line, using the *Programmer* tool in [SimpleLink™ Wi-Fi Toolbox](#).

The CC35xxE device also includes bits for one-time programming (OTP), which are available for customer use. Features such as Mac® address definition, Wi-Fi 6 disable, and country code restriction can be written in OTP. Fuse programming can only be done before activation, also using the Programmer tool of the Simplelink™ Wi-Fi Toolbox. Customers must consider partial fuse programming before running the RF tests in the PLT, to verify those fuses during the PLT.

5 Flash Programming

The final stage of the production line is programming the application image to the external xSPI flash. This programming is only accomplished through the SWD interface of the CC35xxE device using the XDS110 LaunchPad™ Development Kit platform while using the Programmer tool in the SimpleLink™ Wi-Fi Toolbox. The CC35xxE device can only be programmed after activation is completed.

6 Summary

TI provides tools so that OEMs and module vendors can create excellent products with the CC35xxE device, and use these tools to make these products in the production line efficiently and potentially at a more cost-effective rate. All stages of the production line, from the PLT to flashing, can be accomplished easily with TI's SimpleLink™ Wi-Fi Toolbox application.

7 References

- Texas Instruments. [SimpleLink Wi-Fi Toolbox](#), application and user documents.
- Texas Instruments. [CC35xx SimpleLink™ Wi-Fi 6 and Bluetooth® Low Energy Wireless MCU Technical Reference Manual](#).

IMPORTANT NOTICE AND DISCLAIMER

TI PROVIDES TECHNICAL AND RELIABILITY DATA (INCLUDING DATASHEETS), DESIGN RESOURCES (INCLUDING REFERENCE DESIGNS), APPLICATION OR OTHER DESIGN ADVICE, WEB TOOLS, SAFETY INFORMATION, AND OTHER RESOURCES "AS IS" AND WITH ALL FAULTS, AND DISCLAIMS ALL WARRANTIES, EXPRESS AND IMPLIED, INCLUDING WITHOUT LIMITATION ANY IMPLIED WARRANTIES OF MERCHANTABILITY, FITNESS FOR A PARTICULAR PURPOSE OR NON-INFRINGEMENT OF THIRD PARTY INTELLECTUAL PROPERTY RIGHTS.

These resources are intended for skilled developers designing with TI products. You are solely responsible for (1) selecting the appropriate TI products for your application, (2) designing, validating and testing your application, and (3) ensuring your application meets applicable standards, and any other safety, security, regulatory or other requirements.

These resources are subject to change without notice. TI grants you permission to use these resources only for development of an application that uses the TI products described in the resource. Other reproduction and display of these resources is prohibited. No license is granted to any other TI intellectual property right or to any third party intellectual property right. TI disclaims responsibility for, and you fully indemnify TI and its representatives against any claims, damages, costs, losses, and liabilities arising out of your use of these resources.

TI's products are provided subject to [TI's Terms of Sale](#), [TI's General Quality Guidelines](#), or other applicable terms available either on ti.com or provided in conjunction with such TI products. TI's provision of these resources does not expand or otherwise alter TI's applicable warranties or warranty disclaimers for TI products. Unless TI explicitly designates a product as custom or customer-specified, TI products are standard, catalog, general purpose devices.

TI objects to and rejects any additional or different terms you may propose.

Copyright © 2026, Texas Instruments Incorporated

Last updated 10/2025