

# 48W Low-Profile QR Flyback with Integrated GaN Reference Design for Server Auxiliary Power



## Description

This reference design is a 48W, low-profile DC/DC auxiliary power supply targeting server PSU applications. The design features an integrated flyback controller with a Gallium Nitride (GaN) power switch. The design achieves a height of less than 10mm by utilizing a low-profile planar printed circuit board (PCB) transformer, meeting the high power density requirements of modern server PSU applications. The flyback converter UCG28824 incorporates VCC self-bias functionality, which simplifies the planar transformer PCB winding design by eliminating the need for auxiliary windings and associated VCC rectifier circuitry. This supply operates using the PFC bus voltage as an input, and generates two isolated 12V/3A, 24V/0.1A outputs and a non-isolated 18V/0.5A output.

## Features

- <10mm height low-profile design with PCB planar transformer technology
- Compact size (50.0mm × 33.8mm × 9.6mm) and high-power density (48W/in<sup>3</sup>)
- Achieves >92.98% efficiency at 400VDC input
- Additional isolated 24V and non-isolated 18V provided
- Simplified PCB winding design with VCC self-bias feature

## Applications

- [Open rack server \(ORv3\) power supply unit \(PSU\)](#)

## Resources

[PMP41184](#)

Design Folder

[UCG28824](#)

Product Folder

[ATL431](#)

Product Folder

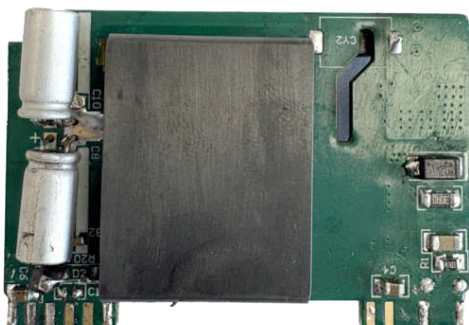

Top View Photo

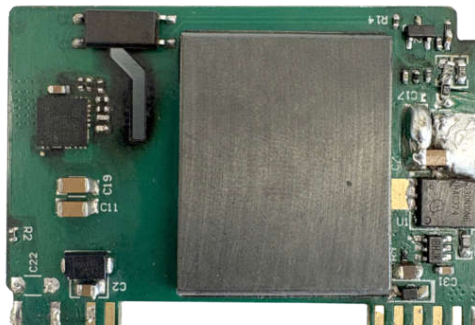

Bottom View Photo

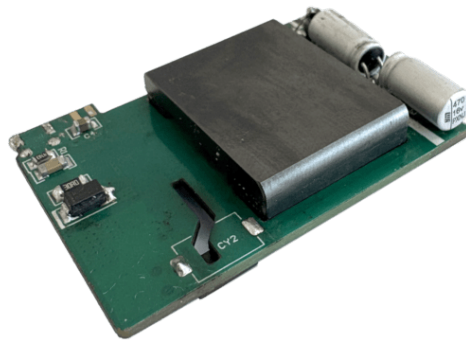

Angled View Photo

## 1 Test Prerequisites

### 1.1 Voltage and Current Requirements

Table 1-1. Voltage and Current Requirements

Parameter	Specifications
Input voltage range	127 VDC–400 VDC
+12V maximum load current	3.0A
+18V PVCC maximum load current	500mA
+24V maximum load current	100mA

### 1.2 Functional Block Diagram

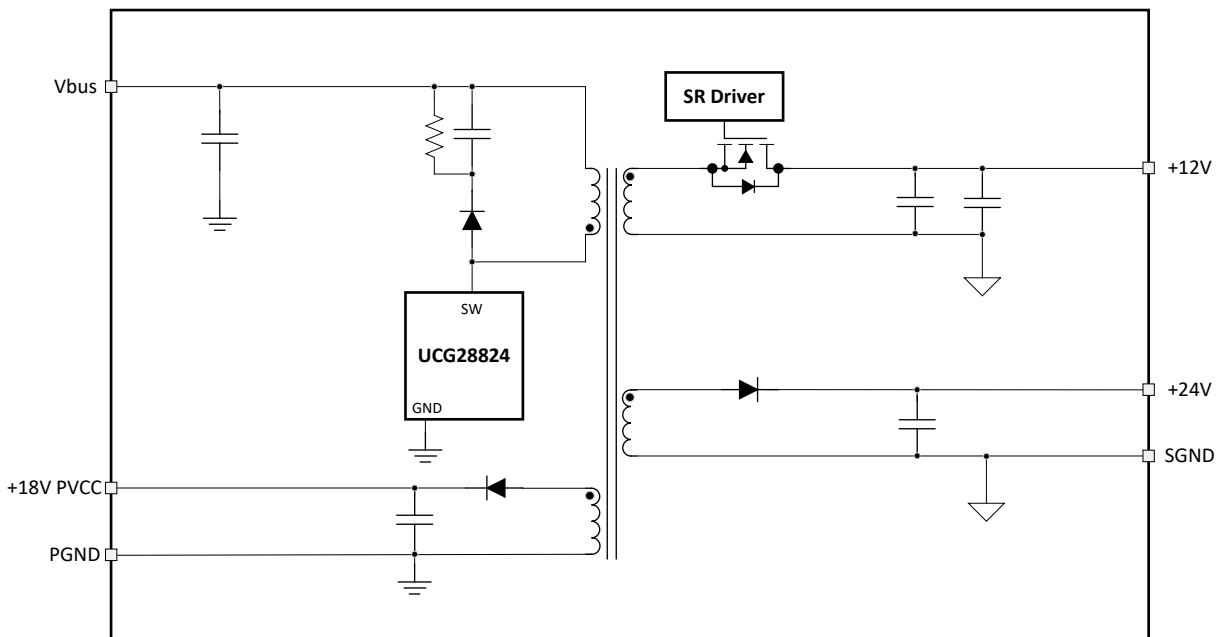

Figure 1-1. Functional Block Diagram

### 1.3 Pin Functions

Table 1-2 provides the functional descriptions of the pins.

**Table 1-2. Pin Functional Descriptions**

Pin Name	Description
Vbus	DC input, connect this pin to input power source, normally the output of a PFC pre-regulator
+18V PVCC	Non-Isolated 18V output, referenced to PGND, this output can supply up to 500mA
PGND	Return path for Vbus, +18V PVCC and all primary referenced circuits
+12V	Main isolated 12V output, it's capable of supplying up to 3A
+24V	Isolated output, maximum output current is 100mA
SGND	Return path for +12V, +24V and all secondary referenced circuits

**1.4 Required Equipment**

- DC source: Chroma 62024P-600-8
- Power meter: YOKOGAWA® WT310
- Electronic load: Chroma 6314A
- Oscilloscope: Tektronix® DPO3054
- Thermal camera: FLUKE® TiS55
- True-RMS-Multimeter: FLUKE 287C

**1.5 Dimensions**

PCB board size: 50.0mm × 33.8mm × 9.6mm

**1.6 Test Setup**

This reference design was based on a customer’s actual system, where the auxiliary power board is assembled on the system motherboard. In that system, the DC input is located very close to PFC bulk capacitors, and the three outputs are placed near the system loads, with some system capacitance present on the motherboard. For standalone testing of the reference design, you must add some capacitors and one inductor on both of input and output sides, as shown in [Figure 1-2](#).

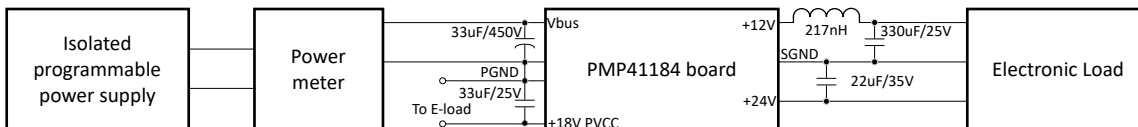
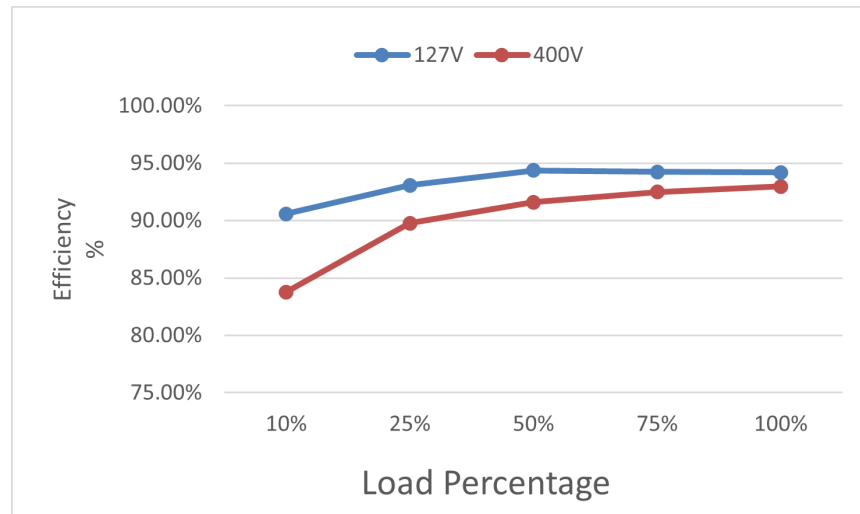

**Figure 1-2. Test Setup**

**2 Testing and Results**

**2.1 Efficiency Graphs**

Efficiency was measured using a DC input source with three outputs loaded. Data was recorded at an input voltage of 127 VDC and 400 VDC. The 127 VDC represents the rectified voltage across the bulk capacitor for a 90 Vac input when the server PSU system is still in the start-up stage and the PFC pre-regulator is not yet active. In contrast, 400 VDC is the nominal bulk voltage after the PFC stage becomes operational.



**Figure 2-1. Efficiency Graph**

## 2.2 Efficiency Data

Efficiency data is shown in [Table 2-1](#).

**Table 2-1. Efficiency Data**

V <sub>IN</sub> (V)	P <sub>IN</sub> (W)	V <sub>OUT1</sub> (V)	I <sub>OUT1</sub> (A)	V <sub>OUT2</sub> (V)	I <sub>OUT2</sub> (A)	V <sub>OUT3</sub> (V)	I <sub>OUT3</sub> (A)	Load (%)	P <sub>OUT</sub> (W)	Efficiency (%)
127	5.15	17.49	0.0466	12.2	0.2963	23.52	0.01	10	4.67	90.58%
127	12.72	17.24	0.1245	12.2	0.7463	23.5	0.025	25	11.84	93.07%
127	25.19	17.43	0.248	12.19	1.4953	24.5	0.05	50	23.78	94.38%
127	37.74	17.4	0.3714	12.19	2.2434	23.48	0.075	75	35.57	94.25%
127	50.37	17.38	0.4977	12.18	2.9925	23.46	0.1	100	47.44	94.19%
400	5.56	17.4	0.0466	12.19	0.2963	23.49	0.01	10	4.66	83.77%
400	13.12	17.31	0.1217	12.19	0.7453	23.46	0.025	25	11.78	89.77%
400	25.8	17.31	0.2478	12.17	1.4934	23.45	0.05	50	23.64	91.61%
400	38.4	17.25	0.3747	12.2	2.2453	23.45	0.0706	75	35.51	92.48%
400	51.04	17.29	0.4998	12.2	2.9944	23.44	0.0975	100	47.46	92.98%

## 2.3 Voltage Regulation

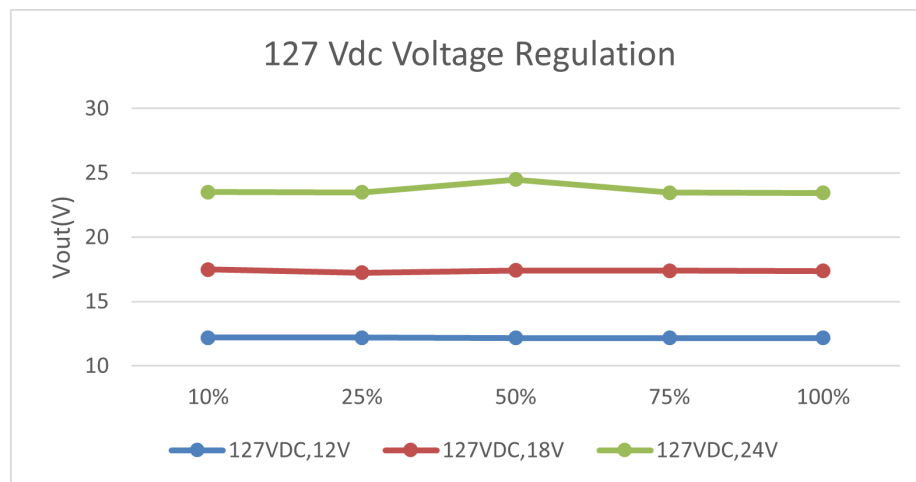

**Figure 2-2. 127 VDC Load Regulation**

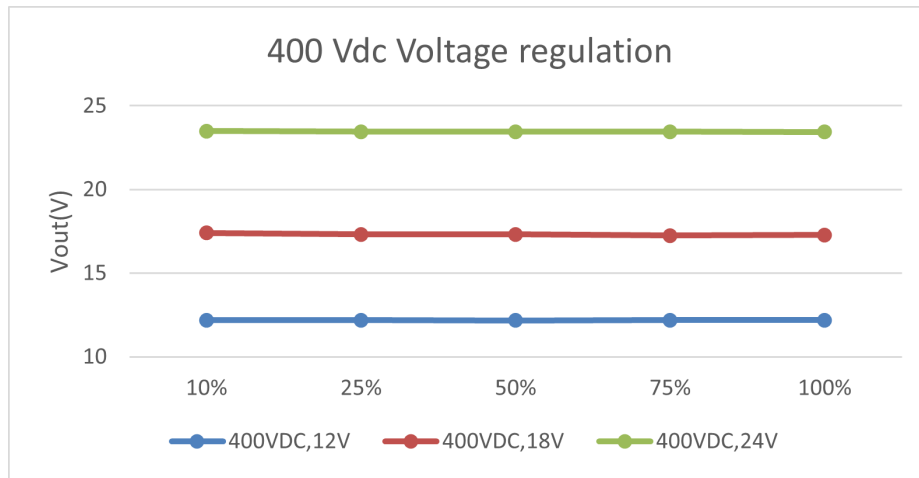

Figure 2-3. 400 VDC Load Regulation

## 2.4 Thermal Images

The thermal test was performed at room temperature, open frame, with a 30 minute warmup.

Table 2-2. Thermal Test Data at Full Load Condition

Temperature	127 VDC	400 VDC
UCG28826	49.3	71.7
Transformer	42.0	48.3
SR MOSFET	45.3	49.8
SR controller	45.1	49.8
+18V PVCC rectifier diode	69.0	79.4

Thermal images are shown in Figure 2-4 and Figure 2-5.

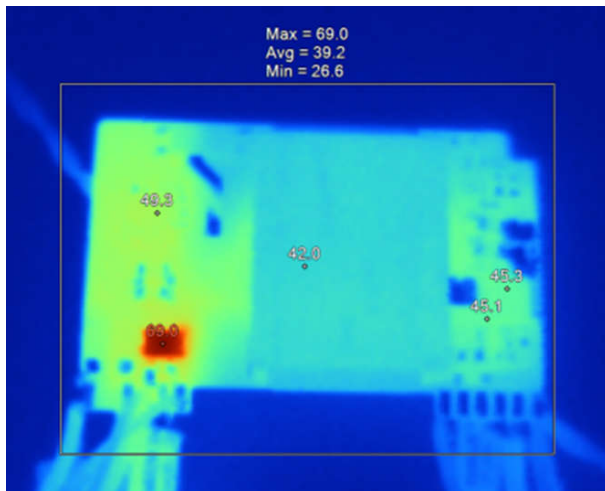

Figure 2-4. 127VDC, Full Load Figure

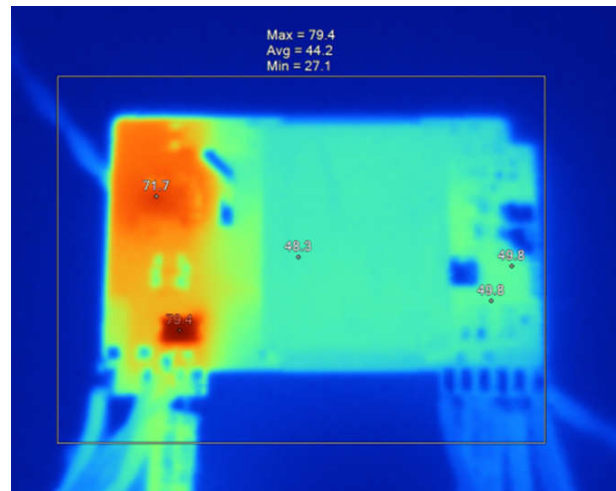

Figure 2-5. 400VDC, Full Load

## 3 Waveforms

### 3.1 Switching

Switching behavior is shown in Figure 3-1 through Figure 3-7.

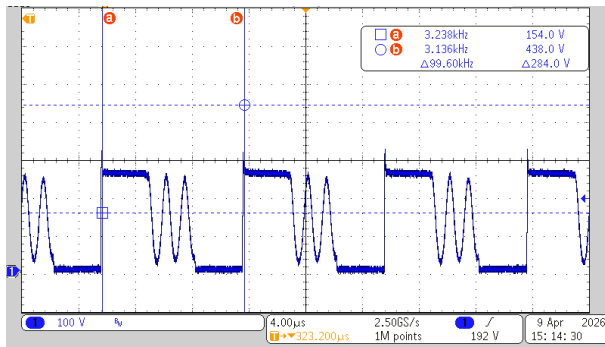

Figure 3-1. 127 VDC, 100% LOAD, Vsw

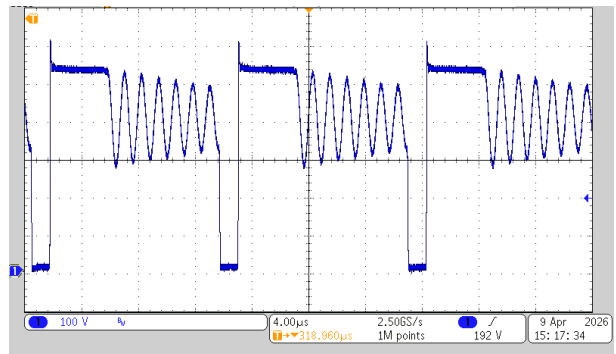

Figure 3-2. 400 VDC, 100% LOAD, Vsw

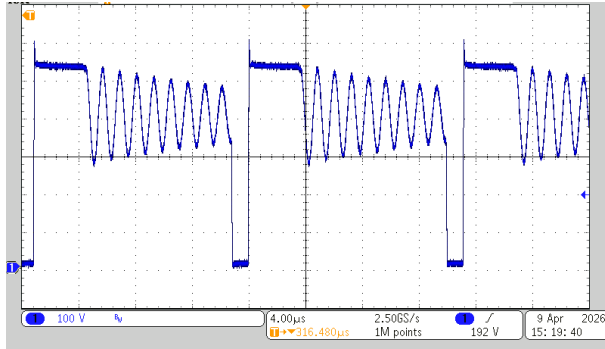

Figure 3-3. 400 VDC, 75% LOAD

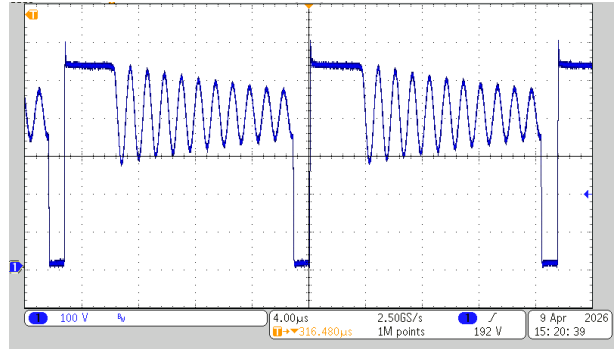

Figure 3-4. 400 VDC, 50% LOAD, Vsw

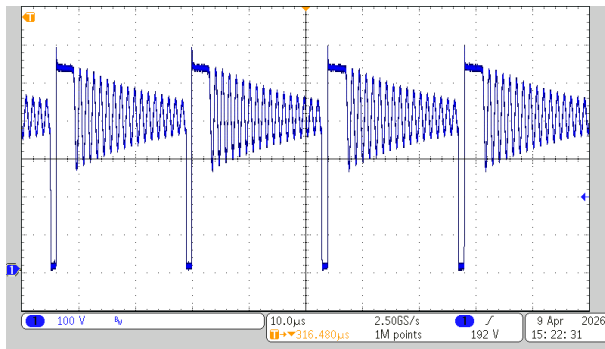

Figure 3-5. 400 VDC, 25% LOAD, Vsw

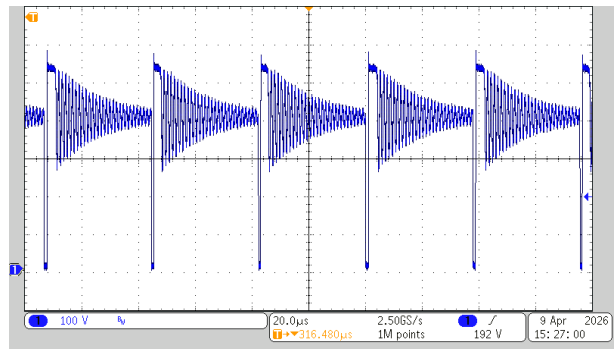

Figure 3-6. 400 VDC, 10% LOAD, Vsw

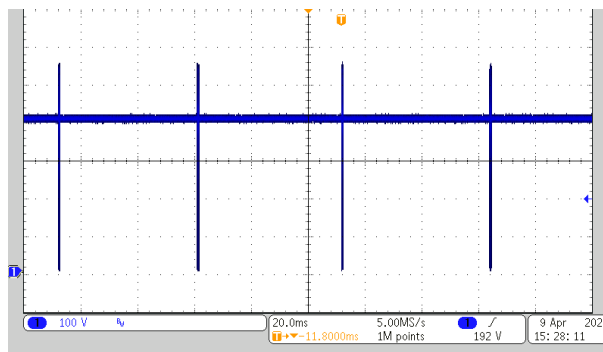

Figure 3-7. 400 VDC, No LOAD, Vsw

### 3.2 Output Voltage Ripple

Output voltage ripple is shown in [Figure 3-8](#) through [Figure 3-12](#).

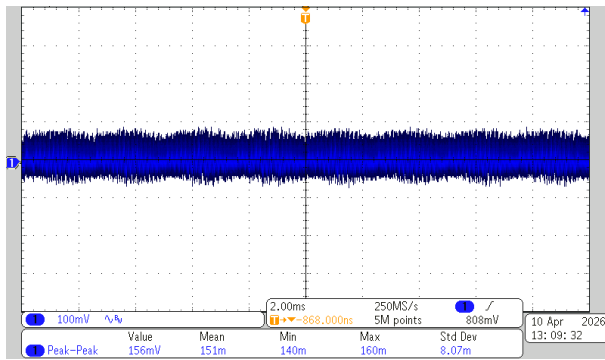

Figure 3-8. 127 VDC, 12Vo, 100% Load Ripple

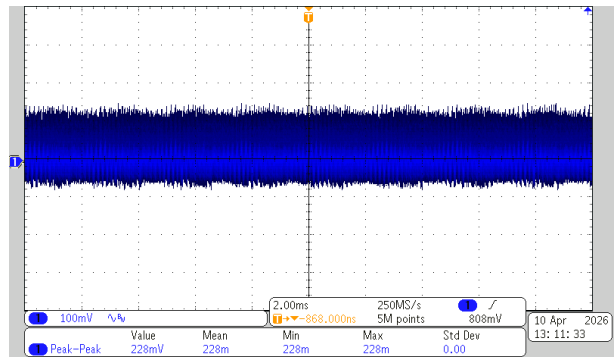

Figure 3-9. 400 VDC, 12Vo, 100% Load Ripple

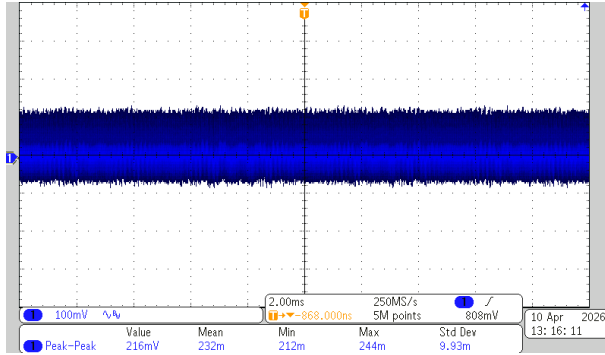

Figure 3-10. 400 VDC, 12Vo, 50% Load Ripple

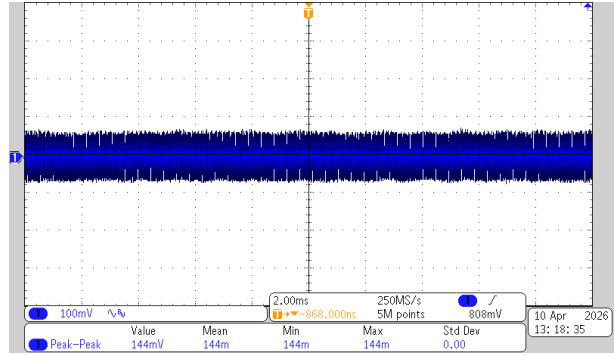

Figure 3-11. 400 VDC, 12Vo, 10% Load Ripple

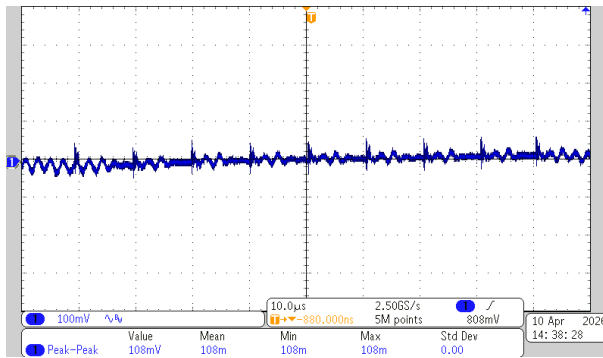

Figure 3-12. 127 VDC, 12Vo, 25% Load Ripple Zoom

### 3.3 Short-Circuit Protection

Short circuit protection was tested at output cable terminals (10cm in length) and the device automatically recovers after the short is removed. CH1:  $V_{OUT}$ , CH3:  $V_{SW}$ , CH4:  $I_{OUT}$

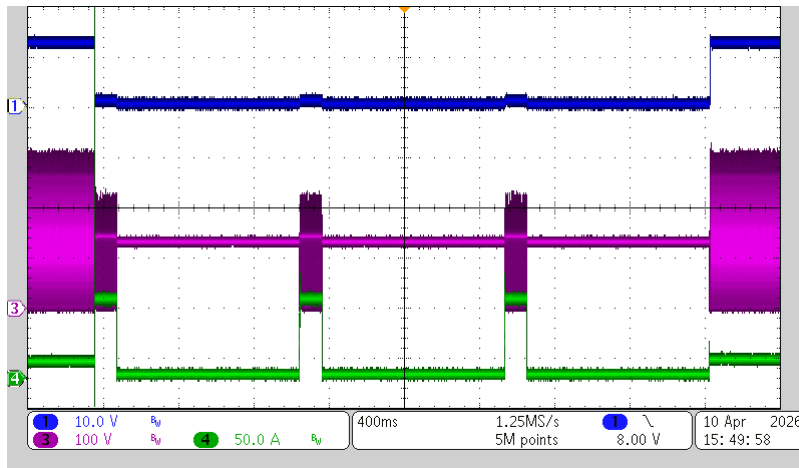

Figure 3-13. Short-Circuit Protection at 127 VDC

### 3.4 Load Transients

The load transient test was performed from 0.1A to full load at +12V output, other outputs at no load. The output voltage was measured at the end of the PCB. CH1:  $V_{OUT}$ , CH3:  $I_{OUT}$

Load transient response is shown in Figure 3-14 and Figure 3-15.

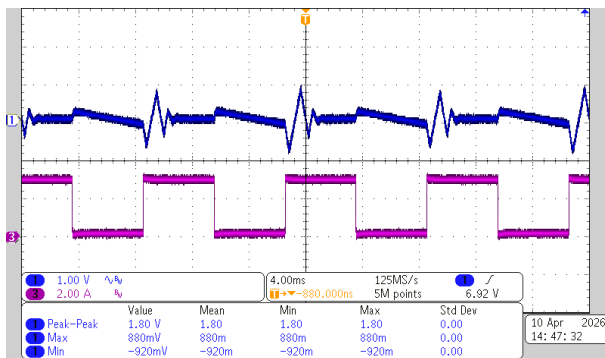

Figure 3-14. 127 VDC, 12V, 0.1A to 3A Load Transient

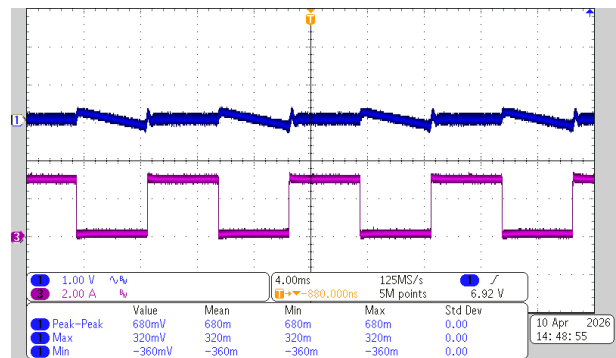

Figure 3-15. 400 VDC, 12V, 0.1A to 3A Load Transient

### 3.5 Start-Up and Shutdown Sequence

Start-up and shutdown behavior are shown in Figure 3-16 through Figure 3-19.

CH1:  $V_{OUT1\_12V}$ , CH2:  $V_{OUT2\_24V}$ , CH3:  $V_{OUT3\_18V}$ , CH4:  $V_{IN\_DC}$

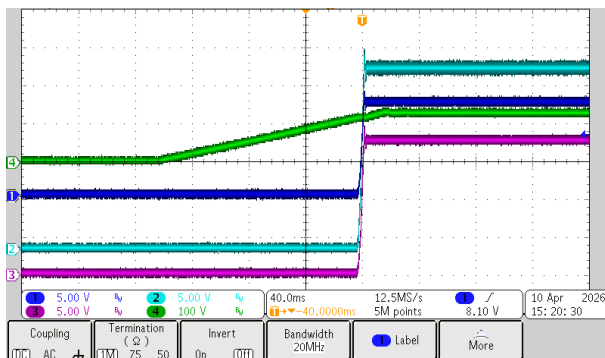

Figure 3-16. 127 VDC, Start-Up

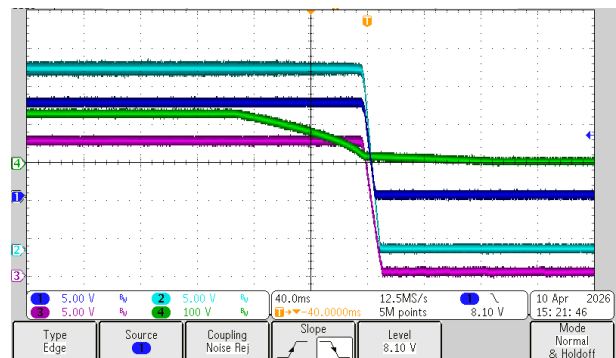

Figure 3-17. 127 VDC, Shutdown

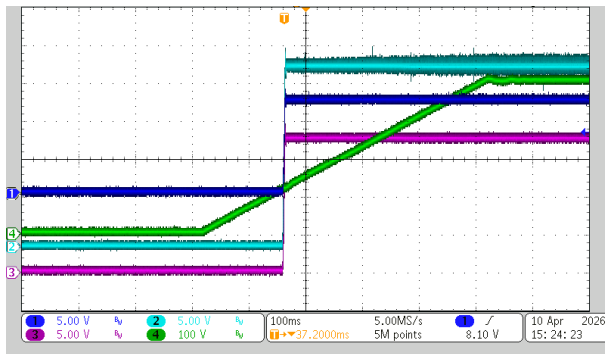

Figure 3-18. 400 VDC, Start-Up

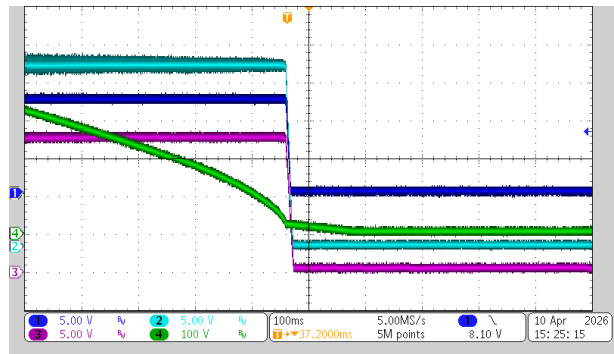

Figure 3-19. 400 VDC, Shutdown

### 3.6 Brown In and Brown Out

Dynamic response is shown in Figure 3-20 and Figure 3-21.

CH1:  $V_{OUT1\_12V}$ , CH2:  $V_{OUT2\_24V}$ , CH3:  $V_{OUT3\_18V}$ , CH4:  $V_{IN\_DC}$

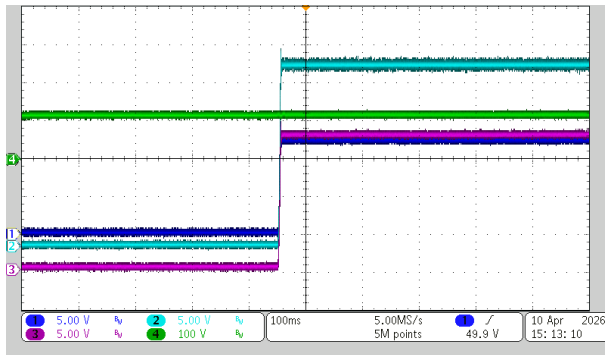

Figure 3-20. DC Brown In at 113V

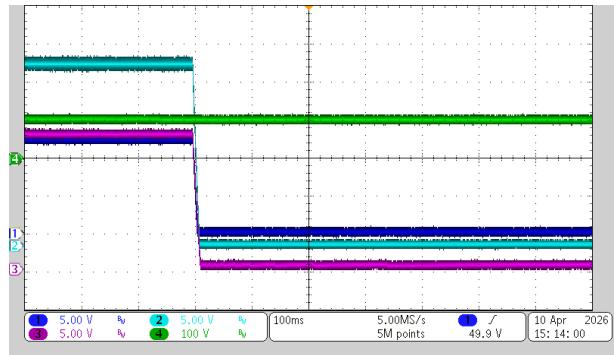

Figure 3-21. DC Brown Out at 99V

### Trademarks

YOKOGAWA® is a registered trademark of Yokogawa Electric Corporation.

Tektronix® is a registered trademark of Tektronix, Inc.

FLUKE® is a registered trademark of Fluke Corporation.

All trademarks are the property of their respective owners.

## IMPORTANT NOTICE AND DISCLAIMER

TI PROVIDES TECHNICAL AND RELIABILITY DATA (INCLUDING DATASHEETS), DESIGN RESOURCES (INCLUDING REFERENCE DESIGNS), APPLICATION OR OTHER DESIGN ADVICE, WEB TOOLS, SAFETY INFORMATION, AND OTHER RESOURCES "AS IS" AND WITH ALL FAULTS, AND DISCLAIMS ALL WARRANTIES, EXPRESS AND IMPLIED, INCLUDING WITHOUT LIMITATION ANY IMPLIED WARRANTIES OF MERCHANTABILITY, FITNESS FOR A PARTICULAR PURPOSE OR NON-INFRINGEMENT OF THIRD PARTY INTELLECTUAL PROPERTY RIGHTS.

These resources are intended for skilled developers designing with TI products. You are solely responsible for (1) selecting the appropriate TI products for your application, (2) designing, validating and testing your application, and (3) ensuring your application meets applicable standards, and any other safety, security, regulatory or other requirements.

These resources are subject to change without notice. TI grants you permission to use these resources only for development of an application that uses the TI products described in the resource. Other reproduction and display of these resources is prohibited. No license is granted to any other TI intellectual property right or to any third party intellectual property right. TI disclaims responsibility for, and you fully indemnify TI and its representatives against any claims, damages, costs, losses, and liabilities arising out of your use of these resources.

TI's products are provided subject to [TI's Terms of Sale](#), [TI's General Quality Guidelines](#), or other applicable terms available either on [ti.com](http://ti.com) or provided in conjunction with such TI products. TI's provision of these resources does not expand or otherwise alter TI's applicable warranties or warranty disclaimers for TI products. Unless TI explicitly designates a product as custom or customer-specified, TI products are standard, catalog, general purpose devices.

TI objects to and rejects any additional or different terms you may propose.

Copyright © 2026, Texas Instruments Incorporated

Last updated 10/2025