

Designing Fault Protection Circuits Using Wide VIN LM5121

Eric Lee and Daniel Braunworth

ABSTRACT

Battery powered systems or systems with low input voltage supplies may have loads that require higher voltage outputs. A boost converter is a usual choice for non-isolated applications; however, boost converters do not naturally provide system protection to downstream circuitry due to the pass path from input to output. Problems due to this pass path are now resolved with the LM5121 boost controller which is designed with a wide input operating range and fault protection features to address systems that experience harsh inputs or load faults. The built-in input disconnect switch control provides inrush limit, output short circuit protection and circuit breaker functions. This application report explores the implementation of and component selection for the protection circuits enabled by LM5121 using its input disconnect switch control feature. This enables inrush protection, output short circuit protection, and circuit breaker functionality. Additional input fault circuit applications and reverse battery protection are also discussed.

Contents

| | | |
|----|---|----|
| 1 | Introduction | 2 |
| 2 | How The Inrush Control Works | 2 |
| 3 | How The Hiccup Mode Output Short Circuit Protection Works | 4 |
| 4 | How The Circuit Breaker Works | 5 |
| 5 | Disconnect MOSFET Selection | 6 |
| 6 | Freewheeling Diode Selection | 7 |
| 7 | Conclusion | 7 |
| 8 | Appendix A: Inrush Current Limit Programming | 8 |
| 9 | Appendix B: Input Over-Voltage Transient Protection | 9 |
| 10 | Appendix C: Reverse Battery Protection | 10 |
| 11 | References | 11 |

1 Introduction

Aside from the core boosting function, the purpose of LM5121 is to provide fault protection that would otherwise be designed discretely or with a separate hot swap type controller. Flexible protection control is integrated with the boost converter to simplify the design. Various fault protection schemes can be achieved including load disconnection, inrush current limiting, hiccup mode short circuit protection, circuit breaker, and input over-voltage transient suppression.

Figure 1 shows the complete schematic of an LM5121 synchronous boost controller with the additional current sense resistor and disconnect FET required for the basic protection control. The following sections will detail the operation of each system-level protection mode and component selection considerations. The appendix expands to share application examples that enable more complex protection like over-voltage transient and reverse polarity protection with simple circuit modifications.

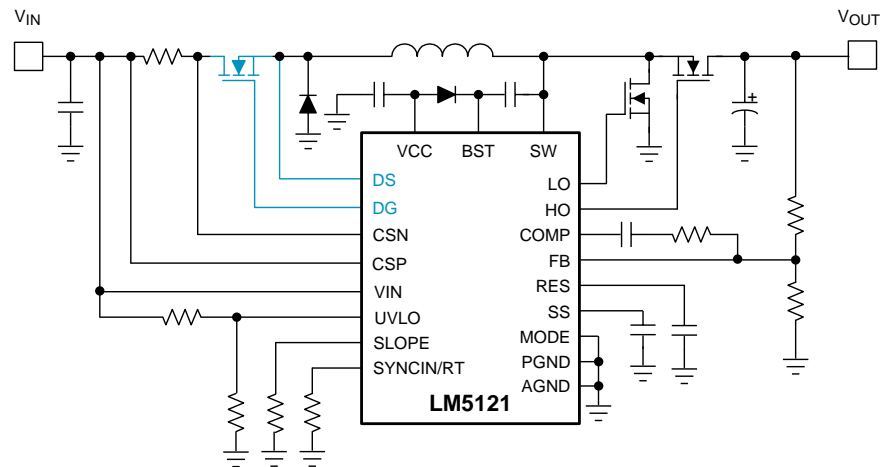

Figure 1. LM5121 Synchronous Boost Controller with Disconnect Switch

2 How The Inrush Control Works

Large output capacitors (C_{OUT}) in the boost converter can cause an excessive inrush current during the initial charging. The sense resistor (R_S), inductor (L_{IN}), and high-side switching device (Q_H) can be damaged by this excessive inrush current.

Solutions to control the amount of inrush current include slowly increasing the input supply voltage (V_{IN}), placing a NTC thermistor, or employing a dedicated hot-swap controller ahead of the boost. But these options require external circuitry, adding cost and increasing total solution size. Especially, an NTC thermistor drops system efficiency, increases board temperature, and does not handle repetitive fault events. The LM5121 boost controller has an integrated inrush current limit circuit which removes the need of dedicated hot-swap or NTC thermistor.

LM5121's internal charge pump turns on when the UVLO pin voltage is greater than the UVLO threshold of 1.2 V. The charge pump is sourced from the VIN pin and sources 25 uA current at the DG pin to enhance an N-channel MOSFET disconnect switch (Q_D).

An internal high-side current sense amplifier senses the voltage across the sense resistor. When the sensed current reaches the 1.1 V inrush current limit threshold (V_{CS-TH2}), the DG pin voltage (V_G) is controlled to limit the current flow in the sense resistor by controlling DG current sink.

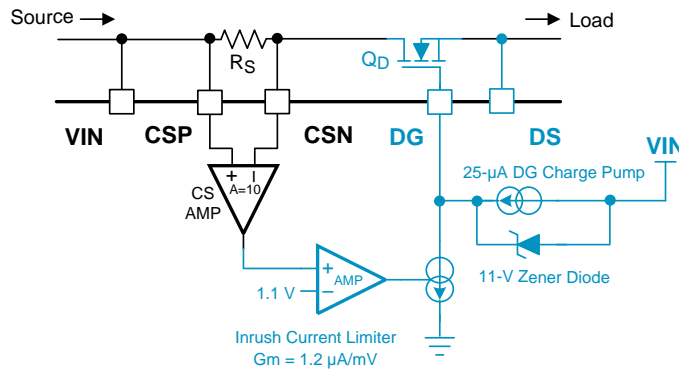

Figure 2. Inrush Current Limit Circuit

The waveform in Figure 3 shows typical inrush current limiting and Figure 4 shows normal startup sequence. As the operating point of the disconnect switch transitions from cut-off to the ohmic region by increasing the gate voltage, the source voltage of the disconnect switch (V_S) is also increased and the drain-to-source voltage (V_{DS}) of the disconnect switch decreases as a result. During this initial output capacitor charging period, controlling the gate-to-source voltage (V_{GS}) of the disconnect switch limits the inrush current. After fully charging up the output capacitors, the amount of inrush current drops dramatically and the gate-to-source voltage increases by the 25 μ A DG sourcing current again since the DG current sink turns off. LM5121 will start its soft-start procedure once the gate-to-source voltage rises above the gate-to-source voltage detection threshold (V_{GS-DET}) of 5.4 V.

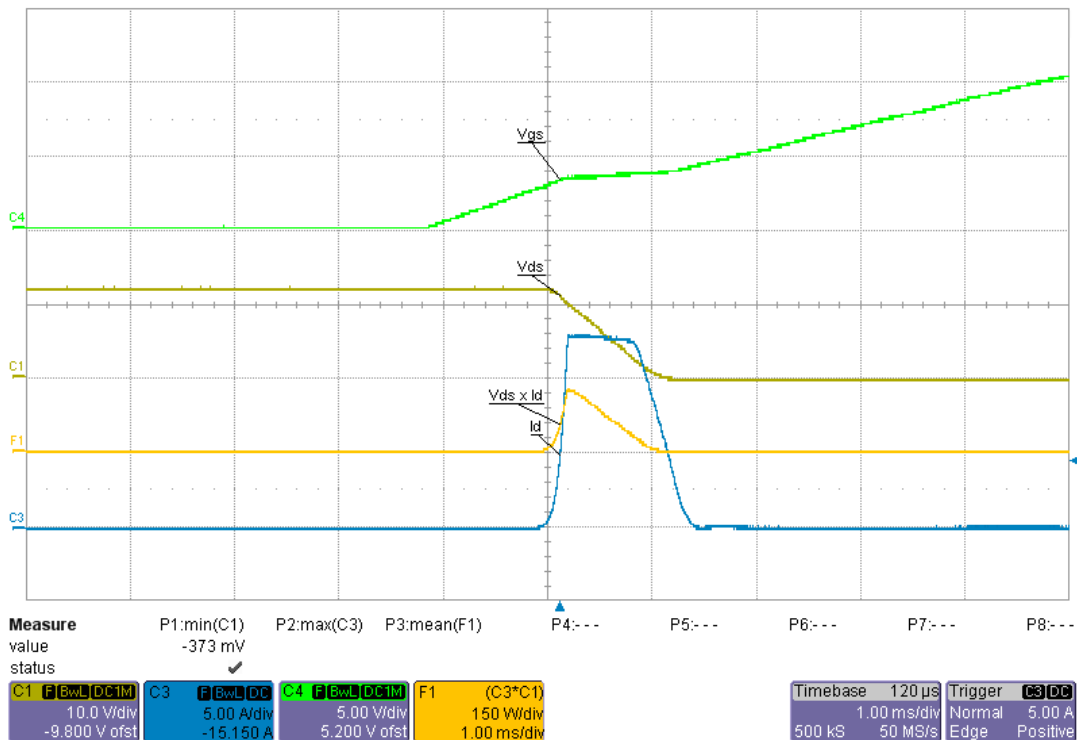

Figure 3. Inrush Current Limit Waveform (C1: V_{DS} , C3: I_D , C4: V_{GS} , F1: $P_{QD}=V_{DS} \times I_D$)

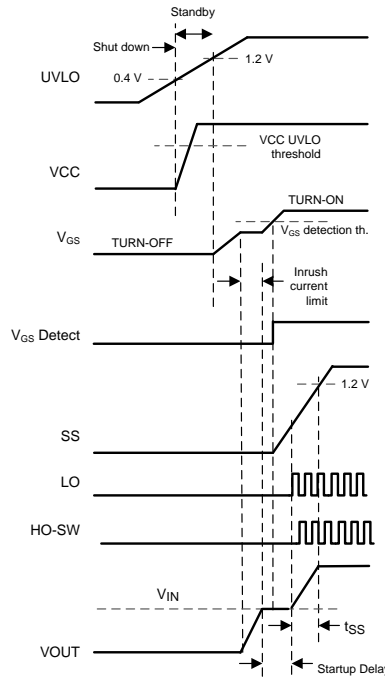

Figure 4. Start-Up Sequence

The DG pin voltage is clamped by an internal 11 V zener diode which is connected from the DG pin to the VIN pin. The VIN pin voltage is allowed to be higher or lower than the input supply voltage when an external bias supply is available for the LM5121. The external VIN pin voltage should be carefully selected since the effective gate-to-source voltage of the disconnect switch is decreased when the VIN pin voltage is lower than the input supply voltage.

See [Section 8](#) for further discussion on programming the inrush current limit.

3 How The Hiccup Mode Output Short Circuit Protection Works

All non-synchronous and synchronous boost converters have a direct path from the source to the load through the high-side switching device. Due to this direct path, there is no way to isolate an output short-circuit fault from the input power source. This absence of output short circuit protection in boost converters demands the use of a fuse in front of the converter for input supply protection.

LM5121 provides hiccup mode output short circuit protection using the disconnect switch. During the hiccup mode operation, LM5121 repeatedly turns off for a given time and then restarts. [Figure 5](#) and [Figure 6](#) show a hiccup mode restart timer programming circuit and the sequence of the hiccup operation.

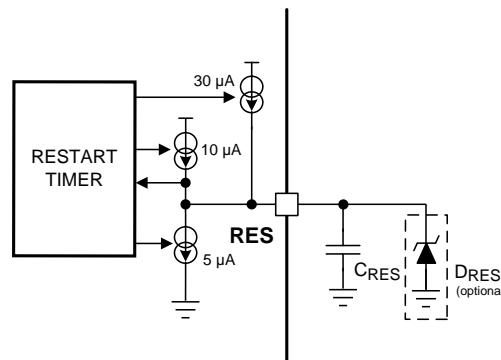

Figure 5. Hiccup Mode Restart Timer Programming Circuit

During normal operation, the timer's normal-state 5 uA discharging current pulls down the RES pin voltage to the ground. If a cycle-by-cycle current limit or inrush current limit is reached, a 30 uA RES fault-state charging current ($I_{RES-SOURCE1}$) charges the RES capacitor (C_{RES}). If the RES pin voltage exceeds the 1.2 V restart threshold after the RES delay in Figure 6 (t_{RD}), a hiccup mode restart sequence is initiated. The RES delay time can be calculated as follows:

$$t_{RD} = \frac{C_{RES} \times 1.2}{30 \mu} \text{ [s]} \quad (1)$$

During the hiccup mode off-time (t_{RES}), switching stops and the DG pin is discharged to ground if the inrush current limit is reached. The RES pin voltage ramps up and down between 2 V and 4 V eight times via a 10 uA RES hiccup mode off-time charging current ($I_{RES-SOURCE2}$) and 5 uA hiccup mode off-time discharging current ($I_{RES-SINK2}$).

After the eight cycles, the inrush current limiting is reactivated, the DG pin is released and charged by the 25 uA DG sourcing current again.

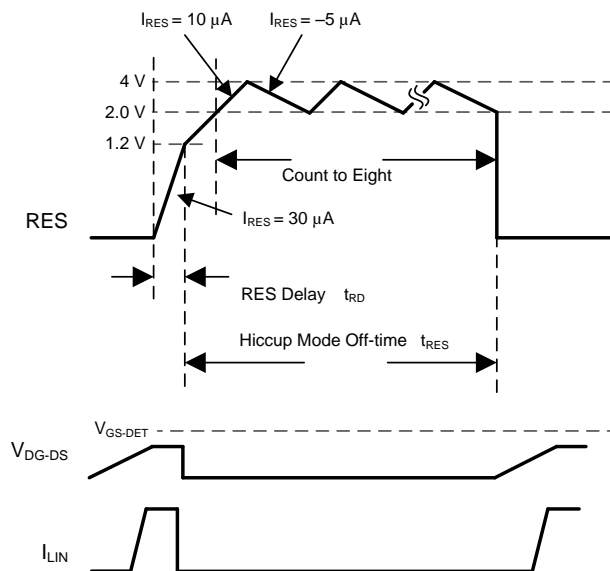

Figure 6. Hiccup Mode Restart Sequence

The ratio between the RES delay (t_{RD}) and hiccup mode off-time is typically 122 and internally set. The total off-time should be programmed to allow enough time to cool down the switch under repetitive restart operation.

By connecting a zener diode (D_{RES}) to the RES pin with characteristics of a sharp knee, 2.4 V to 3.6 V breakdown, and low reverse leakage, the LM5121 will disable the hiccup mode and latch off until reset. The reverse leakage current at 1.2 V should be smaller than the RES fault-state charging current of 10 uA ($I_{RES-SOURCE2}$).

4 How The Circuit Breaker Works

High reliability and robust system design requires ensuring safety in all circumstances. A front-end fuse is often required to mitigate further system damage in a gross fault condition; however, LM5121 provides a circuit breaker function in addition to the hiccup mode protection to add a failsafe disconnect in place of a front end fuse. If the sensed current increases rapidly due to a fault, the current may exceed the inrush current control threshold before the inrush control loop responds. If the sensed current exceeds the 1.6 V circuit breaker threshold (V_{CS-TH3}), a fast-response internal pull down switch quickly discharges the DG pin until the sensed current falls below the 0.11 V circuit breaker disable threshold (V_{CS-TH4}), and then reactivates the inrush current limiting.

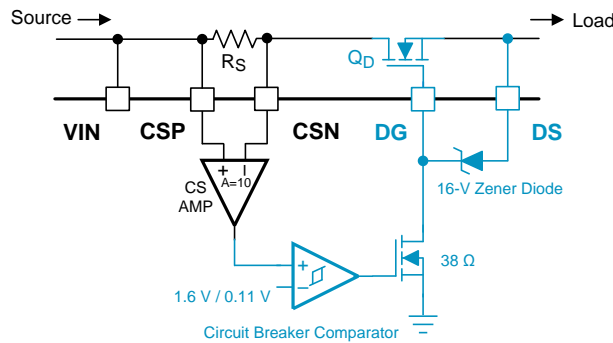
Figure 7. Circuit Breaker Circuit

In addition to the internal 11 V zener clamp from the DG pin to the VIN pin, the DG pin voltage is also clamped by a 16 V zener diode which is connected from DG pin to DS pin. This 16 V zener diode helps the DG-to-DS voltage not to exceed the MOSFET's gate-to-source break down voltage and limits the DG pin voltage from falling below one diode drop of the DS pin voltage when the circuit breaker activated.

5 Disconnect MOSFET Selection

The N-Channel MOSFET disconnect switch should be carefully selected to ensure that LM5121 provides adequate protection without allowing any damage to the MOSFET during the various protection modes. Choose a MOSFET whose drain-to-source breakdown voltage (BV_{DS}) is higher than the maximum input supply voltage plus ringing and transients. The continuous drain current ($I_{D-CONTINUOUS}$) should be high enough to handle the full load input current at the minimum input supply voltage. Choosing a MOSFET whose gate-to-source breakdown voltage (BV_{GS}) is ± 20 V or greater is recommended since the 16 V internal zener diode clamps the maximum gate-to-source voltage to 16 V. The miller plateau voltage ($V_{PLATEAU}$) should be less than the 11 V zener clamp voltage and is recommended to be less than the gate-to-source voltage detection threshold (V_{GS-DET}) of 5.4 V.

If the miller plateau voltage is greater than the gate-to-source voltage detection threshold, LM5121 might start its soft-start procedure before the inrush current limiting is finished since the MOSFET will not be fully enhanced until the gate voltage reaches the miller plateau. In this case, switching could start before V_{OUT} reaches V_{IN} . Refer to Figure 4 for normal startup operation when the miller plateau is below V_{GS-DET} .

If the VIN pin voltage is less than 6.5 V, a logic level MOSFET should be selected since the strength of the DG charge pump is proportional with the VIN pin voltage.

It is okay for the disconnect switch to have a large gate input capacitance (C_{ISS}) since a slow turn on helps to minimize the amount of the inrush current. Insufficient gate-to-source capacitance can cause the gate-to-source voltage to oscillate during inrush current limiting, but an additional external gate-to-source capacitor helps if a lower C_{ISS} MOSFET is selected.

To survive during the output capacitor charging period, the disconnect switch should be capable of handling the energy to charge the output capacitor up to the input supply voltage. This can be checked by comparing the required energy for output charging with the avalanche energy rating of MOSFET or by checking the safe operating area (SOA) graph in the MOSFET datasheet. The maximum output capacitor charging energy is calculated as follows:

$$E_{INRUSH} = \frac{C_{OUT} \times (V_{IN(MAX)})^2}{2} \quad [J] \quad (2)$$

To survive during an output short circuit condition, a more rugged MOSFET is required than calculated based on inrush current limiting. The disconnect switch should be able to handle the maximum inrush current during the RES delay time at the maximum input supply voltage. The amount of controlled inrush current is calculated as follows:

$$I_{INRUSH} = \frac{V_{CS-TH2}}{R_S} \quad [A] \quad (3)$$

The RES delay time should be longer than the time which is required to charge the output capacitor. The duration to charge the output capacitor up to the input supply voltage is:

$$t_{\text{INRUSH}} = C_{\text{OUT}} \times \frac{V_{\text{IN}}}{I_{\text{INRUSH}} - I_{\text{LOAD-STARTUP}}} \quad [\text{s}] \quad (4)$$

where $I_{\text{LOAD-STARTUP}}$ is a preload which exists before fully turning on the boost converter.

From [Figure 6](#) the RES delay time is calculated as follows:

$$t_{\text{RD}} = C_{\text{RES}} \times \frac{1.2}{I_{\text{RES-SOURCE1}}} \quad [\text{s}] \quad (5)$$

where $I_{\text{RES-SOURCE1}}$ is the RES pin fault state charging current which is typically 30 μA .

The required capability to survive during the output short condition is calculated as follows:

$$E_{\text{SHORT}} = \frac{V_{\text{IN(MAX)}} \times V_{\text{CS-TH2}} \times C_{\text{RES}} \times 1.2}{R_{\text{S}} \times I_{\text{RES-SOURCE1}}} \quad [\text{J}] \quad (6)$$

The necessary condition to survive when the circuit breaker is tripped is the harshest condition discussed here and requires a stronger MOSFET than calculated based on short circuit condition. To survive when the circuit breaker is tripped, the switch should be able to handle the energy calculated as follows:

$$E_{\text{CB}} = \frac{V_{\text{IN(MAX)}} \times V_{\text{CS-TH3}} \times C_{\text{RES}} \times 1.2}{R_{\text{S}} \times I_{\text{RES-SOURCE1}}} \quad [\text{J}] \quad (7)$$

Since the ratio between the RES delay and the hiccup mode off-time is 122, this should be enough time to cool down the switch in a repetitive restart condition, but the single pulse avalanche energy rating of the switch should be derated if a design is not thermally optimized. If the repetitive avalanche characteristic is not enough to handle the necessary energy during the repetitive hiccup operation, improve the thermal dissipation using a heat-sink or enable the latch-off mode short circuit protection by connecting the 2.4 V to 3.6 V rated zener diode (D_{RES}) at RES pin. Since a bigger package MOSFET generally has a larger SOA and better thermal dissipation, select the MOSFET as large as is reasonable for the design.

6 Freewheeling Diode Selection

A freewheeling diode (D_{F}) should be placed between the disconnect switch and the inductor. Please refer to [Figure 9](#). This diode conducts only when the disconnect switch turns off quickly, especially in the circuit breaker scenario. If the switch turns off quickly when the inductor current flows, the inductor current continues flowing through this freewheeling diode. The diode should be able to handle 160 mV/Rs of peak current while the inductor current decays, and the voltage rating of the diode must be greater than the maximum input supply voltage, plus ringing and transients. The inductor current decaying time (t_{DF}) is calculated as follows:

$$t_{\text{DF}} = \frac{L_{\text{IN}} \times 0.16}{R_{\text{S}} \times (V_{\text{OUT}} - V_{\text{IN(MIN)}})} \quad [\text{s}] \quad (8)$$

7 Conclusion

With good understanding of the line and load conditions that the boost circuit must survive, these protection features enable a robust design that minimizes front-end circuitry and system reliability concerns. Inrush control will ensure that supplies are not overdrawn on startup. Output short circuit protection protects the system from over-driving a load fault, and the hiccup mode gives a retry opportunity for transient problems without requiring a full system restart. Circuit breaker functionality offers a fast-response and second level of protection from over-current events. While designing for these conditions, careful attention should be paid to the protection component selection to ensure a robust design.

The following appendices give more protection circuit examples including additions to achieve input over-voltage protection and input reverse polarity protection. Modifications for decreasing the inrush current limit for slow startup charging are also detailed.

8 Appendix A: Inrush Current Limit Programming

To enable a controlled startup inrush that is less than the normal operating current limit, the SLOPE pin can be used to program the inrush current limit to a lower level than the cycle-by-cycle current limit. The SLOPE pin is internally grounded under any fault conditions and at startup, which can be used to modify the current limit in those cases. Otherwise, the SLOPE pin voltage is regulated at 1.2 V only when the gate-to-source voltage of the disconnect switch is greater than the gate-to-source voltage detection threshold (V_{GS-DET}) of 5.4 V in normal operation. Normal condition is when the UVLO pin is greater than 1.2 V, VCC voltage is greater than the 4.0 V VCC UVLO threshold, the RES pin voltage is lower than 1.2 V, and there is no thermal shutdown and no circuit breaker operation.

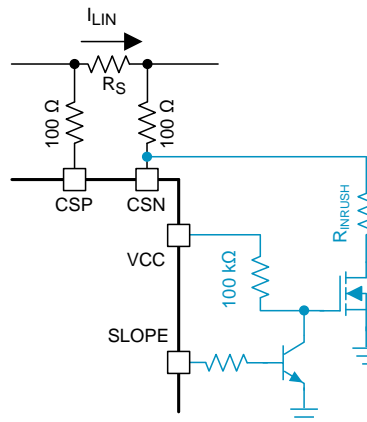

Figure 8. Inrush Current Limit Programming

By adding the inrush programming circuit in [Figure 8](#), the new inrush current limit level can be calculated as follows:

$$I_{INRUSH2} = \frac{V_{CS-TH2} - V_{IN(MAX)} \times \left(\frac{100}{100 + R_{INRUSH}} \right)}{R_S} \text{ [A]} \quad (9)$$

9 Appendix B: Input Over-Voltage Transient Protection

Input over-voltage transient suppression can be easily achieved by adding a zener diode from the DG pin to ground.

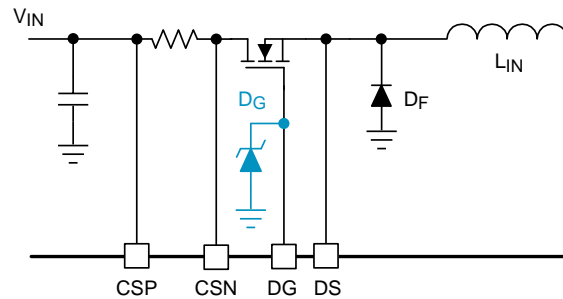

Figure 9. Input Over Voltage Transient Protection

Since the DG pin voltage is clamped to the selected zener voltage (V_{ZENER}) and the N-channel MOSFET turns off when the gate-to-source voltage is lower than the gate threshold voltage, the DS pin voltage is also clamped. The output clamping voltage is calculated as follows:

$$V_{OUT-CLAMP} = V_{ZENER} - V_{GS-TH} \quad [V] \quad (10)$$

Since the disconnect switch operates in the ohmic region during the input over-voltage transient protection, the disconnect MOSFET should be carefully selected, taking into account the safe operating area. The maximum allowable clamping time will be limited by the property of the MOSFET.

10 Appendix C: Reverse Battery Protection

Reverse battery protection prevents damage to downstream circuitry in the event of supply connected into incorrect polarity. LM5121's disconnect switch control can be used to enhance an N-channel reverse battery blocking MOSFET. In Figure 10, the power NMOS acts as a natural disconnect switch when a negative V_{in} voltage keeps the gate discharged. When the battery is properly installed, the signal PMOS turns on and passes the DG sourcing current to the gate of the power NMOS. Power is delivered to the IC through the body diode of the NMOS during startup until the DG sourcing current comes up and enhances the NMOS gate.

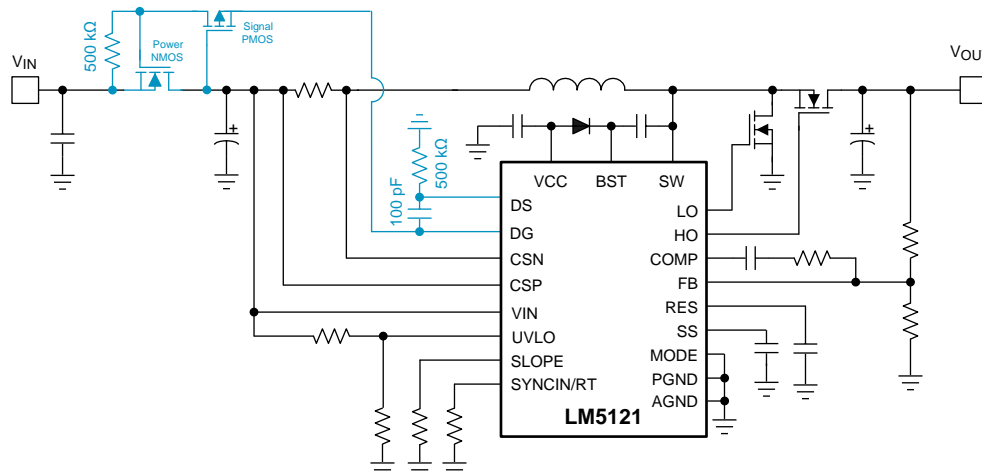

Figure 10. Reverse Battery Protection Circuit

11 References

LM5121 Wide Input Synchronous Boost Controller with Disconnect Switch Control ([SNVS963](#))

LM5122 Wide Input Synchronous Boost Controller with Multi Phase Capability ([SNVS954](#))

LM5060 High-Side Protection Controller with Low Quiescent Current ([SNVS628](#))

CSD19536KCS 100 V N-Channel NexFET™ Power MOSFET ([SLPS485](#))

Revision History

| DATE | REVISION | NOTES |
|--------------|-----------------|------------------|
| January 2015 | * | Initial release. |

IMPORTANT NOTICE

Texas Instruments Incorporated and its subsidiaries (TI) reserve the right to make corrections, enhancements, improvements and other changes to its semiconductor products and services per JESD46, latest issue, and to discontinue any product or service per JESD48, latest issue. Buyers should obtain the latest relevant information before placing orders and should verify that such information is current and complete. All semiconductor products (also referred to herein as "components") are sold subject to TI's terms and conditions of sale supplied at the time of order acknowledgment.

TI warrants performance of its components to the specifications applicable at the time of sale, in accordance with the warranty in TI's terms and conditions of sale of semiconductor products. Testing and other quality control techniques are used to the extent TI deems necessary to support this warranty. Except where mandated by applicable law, testing of all parameters of each component is not necessarily performed.

TI assumes no liability for applications assistance or the design of Buyers' products. Buyers are responsible for their products and applications using TI components. To minimize the risks associated with Buyers' products and applications, Buyers should provide adequate design and operating safeguards.

TI does not warrant or represent that any license, either express or implied, is granted under any patent right, copyright, mask work right, or other intellectual property right relating to any combination, machine, or process in which TI components or services are used. Information published by TI regarding third-party products or services does not constitute a license to use such products or services or a warranty or endorsement thereof. Use of such information may require a license from a third party under the patents or other intellectual property of the third party, or a license from TI under the patents or other intellectual property of TI.

Reproduction of significant portions of TI information in TI data books or data sheets is permissible only if reproduction is without alteration and is accompanied by all associated warranties, conditions, limitations, and notices. TI is not responsible or liable for such altered documentation. Information of third parties may be subject to additional restrictions.

Resale of TI components or services with statements different from or beyond the parameters stated by TI for that component or service voids all express and any implied warranties for the associated TI component or service and is an unfair and deceptive business practice. TI is not responsible or liable for any such statements.

Buyer acknowledges and agrees that it is solely responsible for compliance with all legal, regulatory and safety-related requirements concerning its products, and any use of TI components in its applications, notwithstanding any applications-related information or support that may be provided by TI. Buyer represents and agrees that it has all the necessary expertise to create and implement safeguards which anticipate dangerous consequences of failures, monitor failures and their consequences, lessen the likelihood of failures that might cause harm and take appropriate remedial actions. Buyer will fully indemnify TI and its representatives against any damages arising out of the use of any TI components in safety-critical applications.

In some cases, TI components may be promoted specifically to facilitate safety-related applications. With such components, TI's goal is to help enable customers to design and create their own end-product solutions that meet applicable functional safety standards and requirements. Nonetheless, such components are subject to these terms.

No TI components are authorized for use in FDA Class III (or similar life-critical medical equipment) unless authorized officers of the parties have executed a special agreement specifically governing such use.

Only those TI components which TI has specifically designated as military grade or "enhanced plastic" are designed and intended for use in military/aerospace applications or environments. Buyer acknowledges and agrees that any military or aerospace use of TI components which have **not** been so designated is solely at the Buyer's risk, and that Buyer is solely responsible for compliance with all legal and regulatory requirements in connection with such use.

TI has specifically designated certain components as meeting ISO/TS16949 requirements, mainly for automotive use. In any case of use of non-designated products, TI will not be responsible for any failure to meet ISO/TS16949.

Products

| | |
|------------------------------|--|
| Audio | www.ti.com/audio |
| Amplifiers | amplifier.ti.com |
| Data Converters | dataconverter.ti.com |
| DLP® Products | www.dlp.com |
| DSP | dsp.ti.com |
| Clocks and Timers | www.ti.com/clocks |
| Interface | interface.ti.com |
| Logic | logic.ti.com |
| Power Mgmt | power.ti.com |
| Microcontrollers | microcontroller.ti.com |
| RFID | www.ti-rfid.com |
| OMAP Applications Processors | www.ti.com/omap |
| Wireless Connectivity | www.ti.com/wirelessconnectivity |

Applications

| | |
|-------------------------------|--|
| Automotive and Transportation | www.ti.com/automotive |
| Communications and Telecom | www.ti.com/communications |
| Computers and Peripherals | www.ti.com/computers |
| Consumer Electronics | www.ti.com/consumer-apps |
| Energy and Lighting | www.ti.com/energy |
| Industrial | www.ti.com/industrial |
| Medical | www.ti.com/medical |
| Security | www.ti.com/security |
| Space, Avionics and Defense | www.ti.com/space-avionics-defense |
| Video and Imaging | www.ti.com/video |

TI E2E Community

e2e.ti.com