

EVM User's Guide: AUDIO-AM275-EVM AUDIO-AM62D-EVM DP83867 Evaluation Module



Description

DP83867-EVM-AM is an Industrial Ethernet PHY add-on board to be used with Arm®-based, high-performance microcontroller evaluation modules. This add-on board is an excellent choice for initial Ethernet evaluation and prototyping using EVMs. DP83867-EVM-AM is equipped with a TI DP83867IR low latency 10/100/1000Mbps PHY with RGMII interface and a standard RJ45 Ethernet networking connector. DP83867-EVM-AM is supported on EVMs that have an Ethernet expansion connector such as the [AUDIO-AM275-EVM](#).

Features

- [DP83867IR](#) low latency 10/100/1000Mbps Industrial Ethernet PHY with RGMII interface
- Standard RJ45 Ethernet networking connector
- Shielded DF40GB 48-pin connector for interfacing with Arm-based Processors series evaluation modules



1 Evaluation Module Overview

Preface: Read This First

For the proper mounting instructions, please refer to [Installation](#).

Note

TI does **NOT** recommend mounting Ethernet add-on boards without mounting hardware. TI is not responsible for any damaged caused by using the add-on board without the proper mounting hardware installed.

1.1 If You Need Assistance

If you have any feedback or questions, support for the EVM Industrial Ethernet PHY Add-on Board development kit is provided by the TI Product Information Center (PIC) and the [TI E2E™ Forum](#). Contact information for the PIC can be found on the [TI website](#). Additional device-specific information can be found in [Section 5.1](#).

1.1 Introduction

The Arm-based processor EVM Industrial Ethernet PHY Add-on Board was developed to enable additional Ethernet peripheral support on various EVMs and allow for rapid prototyping of the core SoC for Industrial Ethernet applications. This user's guide details the design of the add-on board and how to properly use the interface. This user's guide also details many important aspects of the board including, but not limited to pin header descriptions, test points, and signal routing.

1.2 Kit Contents

The EVM Industrial Ethernet PHY Add-on Board kit contains the following items:

- DP83867-EVM-AM Industrial Ethernet PHY Add-on Board
- Board mounting hardware

Not included:

- EVM

Note

DP83867-EVM-AM can be available as a virtual bundle with select EVMs. Visit the EVM product page ([DP83867-EVM-AM](#)) for more information.

1.3 Device Information

The DP83867 is a fully featured Physical Layer transceiver with integrated PMD sub-layers to support 10BASE-T_e, 100BASE-TX and 1000BASE-T Ethernet protocols.

The DP83867 is designed for easy implementation of 10/100/1000Mbps Ethernet LANs. The device interfaces directly to twisted pair media through an external transformer. This device interfaces directly to the MAC layer through the IEEE 802.3u Standard Media Independent Interface (MII), the IEEE 802.3z Gigabit Media Independent Interface (GMII), or Reduced GMII (RGMII).

The DP83867 provides precision clock synchronization, including a synchronous Ethernet clock output. The device has low jitter, low latency and provides IEEE 1588 Start of Frame Detection for time sensitive protocols.

The DP83867 offers remarkable diagnostic features including dynamic link quality monitoring for fault prediction during normal operation. The device can support up to 130m cable length.

For additional information, refer to the [DP83867IR Datasheet](#).

2.2 Power Requirements

The EVM Industrial Ethernet PHY Add-on Board is powered from a 3.3V input from the DF40GB 48-pin connector that interfaces the DP83867-EVM-AM with the main EVM. The following sections describe the power distribution network topology that supply the EVM Industrial Ethernet PHY Add-on Board, supporting components, and reference voltages.

2.2.1 Power Tree

The DP83867-EVM-AM power is supplied from the main EVM via the DF40GB connector.

3.3V (VCC_3V3_SYS) is connected to pin 44 and 46 on the DF40GB connector, and is passed to the source input, VDDIO, on the DP83867IR Industrial Ethernet PHY.

2.5V (VDD_2V5) is connected to pin 4 and 6 on the DF40GB connector, and is passed as input to the LDO (TLV75510PDQNR) which outputs 1.0V (VDD_1V0). VDD_2V5 is connected to VDDA_2P5 inputs and VDD_1V0 is connected to VDD1P0 inputs of the Ethernet PHY.

Figure 2-3 shows the power connections of DP83867-EVM-AM.

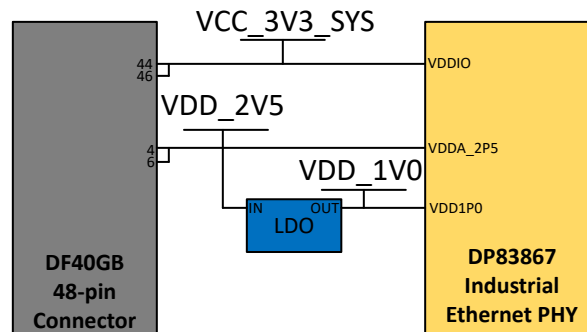

Figure 2-3. Power Tree

2.3 Functional Block Diagram

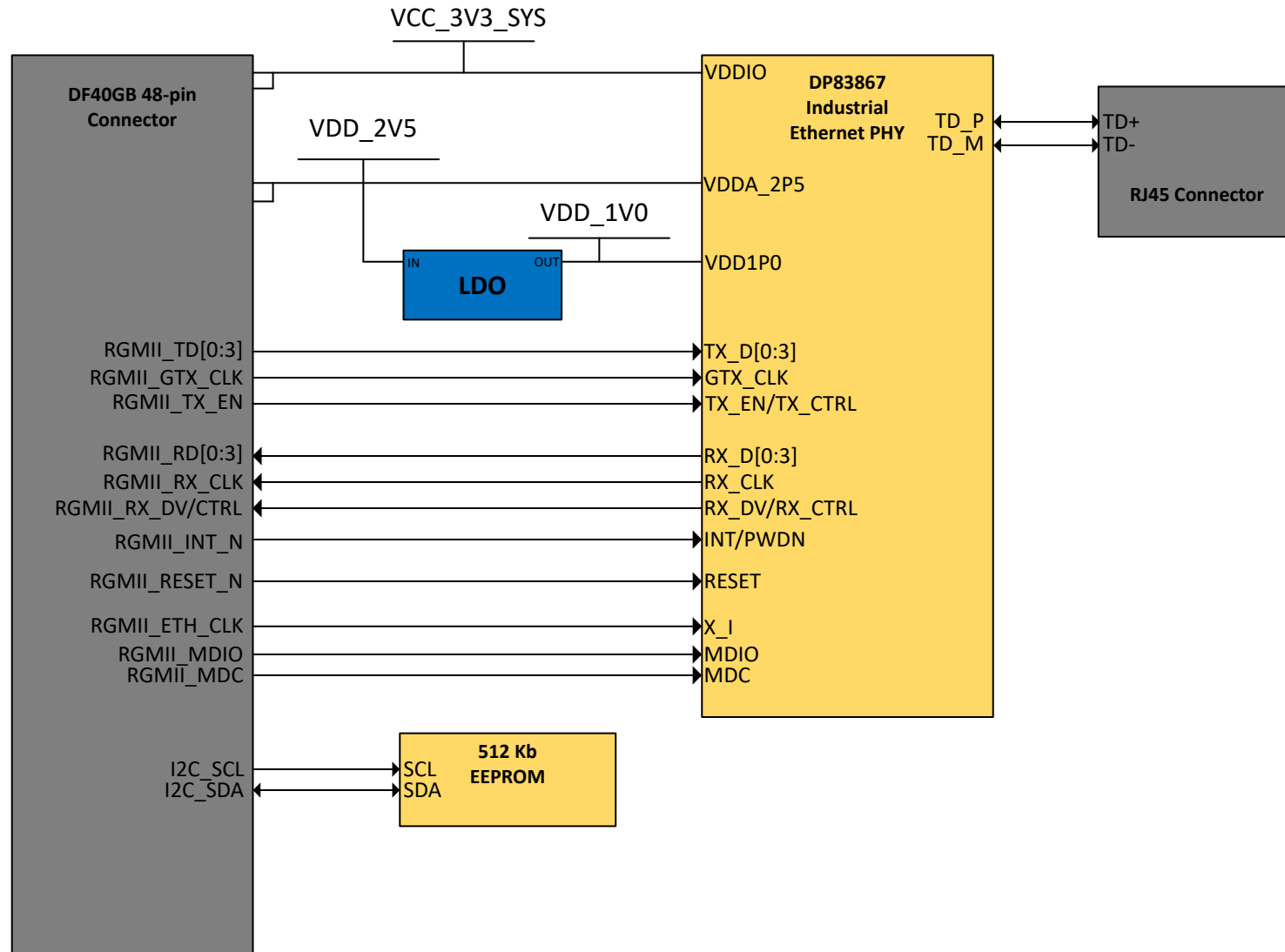

Figure 2-4. AMx Industrial Ethernet PHY Add-on Board Block Diagram

2.4 Header Information

The DP83867-EVM-AM is equipped with a [Hirose DF40GB](#) 2x24-pin connector (J1) to connect to AMx EVMs. Listed below are the features of this connector relevant to this EVM:

- 2x24 pins
- Shielded type to support high-speed signals and prevent noise
- High density mounting

Refer to [Table 2-1](#) for a complete list of the header pins and descriptions.

Table 2-1. DF40GB Header Pinout

Pin #	Signal	Description	Description	Signal	Pin #
1	GND	Ground	External Voltage Monitor	EXT_VMON	2
3	TX_CLK	Transmit Clock	2.5V supply	VDD_2V5	4
5	GND	Ground	2.5V supply	VDD_2V5	6
7	TX_D0	Transmit Data 0	Ground	GND	8
9	TX_D1	Transmit Data 1	Interrupt To Ethernet PHY	PWDN/INTn	10
11	TX_D2	Transmit Data 2	Reset input to Ethernet PHY	RESETn	12
13	TX_D3	Transmit Data 3	Collision Detected	COL	14
15	GND	Ground	Ground	GND	16
17	GND	Ground	Ground	GND	18
19	RX_CLK	Receive Clock	MDIO Clock	MDIO_MDC	20
21	GND	Ground	MDIO Data	MDIO_MDIO	22
23	RX_D0	Receive Data 0	Ground	GND	24
25	RX_D1	Receive Data 1	Inhibit	INH	26
27	RX_D2	Receive Data 2	25MHz Ref. clock	REF_CLK	28
29	RX_D3	Receive Data 3	Carrier Sense	CRS	30
31	GND	Ground	Ground	GND	32
33	GND	Ground	Ground	GND	34
35	TXEN	Transmit Enable	Board Connection Detect	BRD_CONN_DET	36
37	EEPROM_A2	EEPROM I2C Address bit [2]	IEEE 1588 SFD	1588_SFD	38
39	RX_ER	Receive Data Error	I2C Clock	I2C_SCL	40
41	GND	Ground	I2C Data	I2C_SDA	42
43	ETH_GPIO0	ETH GPIO0	IO Voltage Supply	VDDIO	44
45	RXDV	Receive Data Valid	IO Voltage Supply	VDDIO	46
47	EEPROM_A0	EEPROM I2C Address bit [0]	RGMII ETH CLKOUT	CLKOUT	48

2.5 Test Points

DP83867-EVM-AM is equipped with multiple test points for hardware debug and bench testing. [Table 2-2](#) shows the test points on the board and the signal net associated with each test point.

Table 2-2. DP83867-EVM-AM Test Points

Test Point	Signal	Description
TP1	VCC	RJ45 VCC
TP2	VDDA1P8	Analog 1.8V Input
TP3	ETH_LED0	Link established indicator
TP4	CLK_OUT	ETH PHY Ref. Clk out
TP5	EXT_VMON	External voltage monitor
TP6	ETH_GPIO0	PHY GPIO0
TP7	ETH_GPIO1	PHY GPIO1
TP8	VDD_1V0	1.0V LDO Output
TP9	INH	Inhibit
TP10	1588_SFD	1588 Start of frame
TP11	COL	Collision detected
TP12	CRS	Carrier sense
TP13	RX_ER	Receive error

2.6 Interfaces

2.6.1 Ethernet Interface

2.6.1.1 Industrial Ethernet PHY

The AMx EVM Industrial Ethernet PHY Add-on Board uses one port of RGMII signals to be connected to a 32-pin Ethernet PHY (DP83867IR). The PHY is configured to advertise 10/100/1000Mb operation. The Ethernet data signals of the PHY are terminated to an RJ45 Connector. LEDs are used to indicate link status and activity.

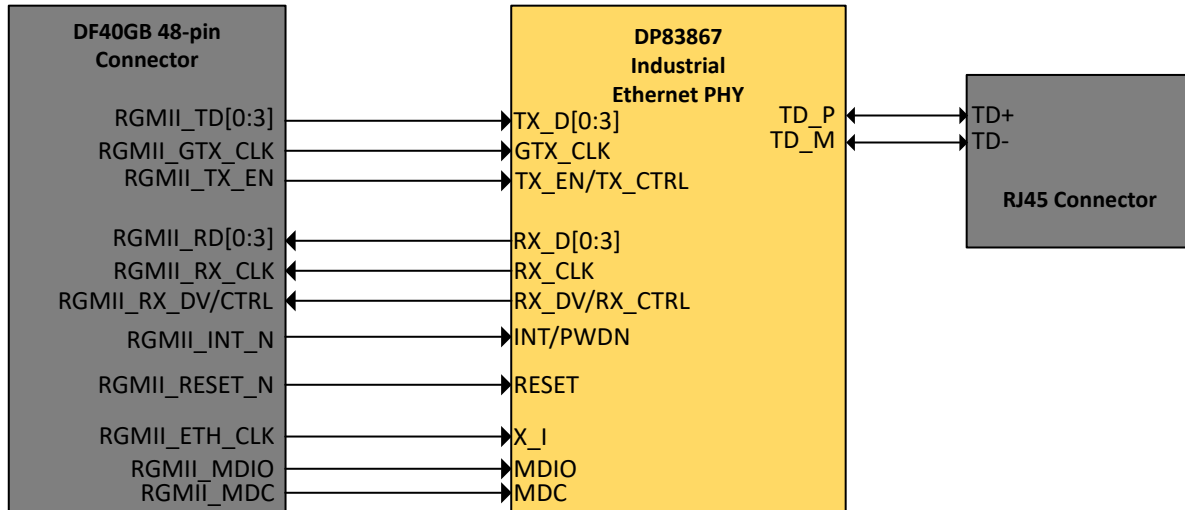

Figure 2-5. Industrial Ethernet PHY

The Ethernet PHY requires three power sources: VDDIO (3.3V or 1.8V), VDDA2P5 (2.5V), and VDD1P0 (VDD_1V0), which are supplied through the DF40GB connector (J1).

On some EVMs, the RGMII port of the CPSW signals are internally muxed on the same balls of the MCU as the PRU-ICSS Ethernet signals. To use RGMII, the balls must be set to the appropriate mux mode for RGMII.

The MDIO and Interrupt signals from the main EVM SoC to the PHY require 2.2k Ω pullup resistors to the I/O supply voltage for proper operation. These resistors are not assembled by default on the DP83867-EVM-AM, but there are footprints if the main EVM does not have these signals pulled up. The interrupt signal is driven by a GPIO signal that is mapped from the main EVM SoC.

The reset signal for the Ethernet PHY is most often driven by a 2-input AND gate. The inputs of the AND gate are a GPIO signal that is generated by the main SoC EVM and a reset status signal on the main EVM.

2.6.1.2 Industrial Ethernet PHY Strapping Resistors

The Ethernet PHY uses many functional pins as strap option to place the device into specific modes of operation.

Note

The DP83867-EVM-AM is designed for a VDDIO voltage of 3.3V. If this board is connected to a 1.8V VDDIO system, then the strapping resistors must be updated. For complete details on the strapping resistor modes, refer to the 4-Level Strap Resistor Ratios table within the [DP83867IR Datasheet](#).

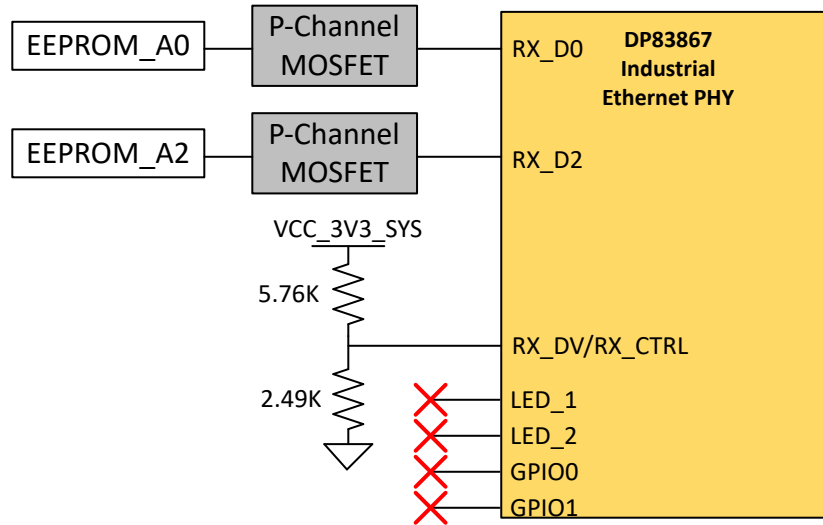

Figure 2-6. Industrial Ethernet PHY Strapping Resistors

Table 2-3. Industrial 10/100/1000Mbit Ethernet PHY Strapping Resistors

Functional Pin	Mode on DP83867-EVM-AM	Function
RX_D0	EEPROM_A0	PHY address: 0[EEPROM_A2][EEPROM_A0]. See Section 2.6.1.4 for more information on PHY addressing.
RX_D2	EEPROM_A2	
RX_DV/RX_CTRL	3	Auto negotiation enabled
LED_1	1	Clock Skew TX[2] = 2ns Advertisability of 10/100/1000Mbps
LED_2	1	Clock Skew TX[1] = 2ns Clock Skew TX[0] = 2ns
GPIO0	1	Clock Skew RX[0] = 2ns
GPIO1	1	Clock Skew RX[2] = 2ns Clock Skew RX[1] = 2ns

2.6.1.3 LED Indication in RJ45 Connector

The EVM Industrial Ethernet PHY Add-on Board has one RJ45 network ports for the RGMII port of the main EVM SoC. The RJ45 connector contains two bi-color LEDs that are used to indicate link and activity.

- RJ45 Connector LED indication for the RGMII port:

Table 2-4. ICSSM PRU1 RJ45 Connector LED indication

LED	Color	Indication
Right LED	Green	Ethernet PHY power established
	Yellow	10BT speed link is up
Left LED	Green	Ethernet activity indicator
	Yellow	GPIO0

2.6.1.4 Multi-Connector Addressing

For AMx EVMs with more than one Ethernet add-on board connector, each DP83867-EVM-AM requires a different EEPROM I2C address and PHY address. The EEPROM A0 and A2 nets, set by pull resistors on the main EVM drive the PHY address nets through a FET network implemented on the DP83867-EVM-AM. [Table 2-5](#) details the multi-connector I2C and PHY addressing scheme implemented on the add-on PHY board.

Note

- The EEPROM I2C address bits A2 and A0 are driven through pull resistors on the main EVM. The pull resistors for each enumerated connector follow the table below.
- EEPROM I2C address bit A1 are *always* be pulled high to VDDIO on the add-on board.
- The EEPROM I2C address is defined by the following 8 bits: 8b1010[A2][A1][A0][R/W].
- Pulls to VDDIO/GND are through 10kΩ resistor.
- All EVMs with a single connector are configured as CONNECTOR_0.

Table 2-5. Multi-Connector I2C / PHY Addressing Scheme

Connector_#	EEPROM_A2 (connector pin 37)		EEPROM_A1		EEPROM_A0 (connector pin 47)		I2C Address	DP83867 PHY Address
	Pull	A2	Pull	A1	Pull	A0		
CONNECTOR_0	GND	0	VDDIO	1	GND	0	0x52	5b00000
CONNECTOR_1	GND	0	VDDIO	1	VDDIO	1	0x53	5b00001
CONNECTOR_2	VDDIO	1	VDDIO	1	GND	0	0x56	5b00100
CONNECTOR_3	VDDIO	1	VDDIO	1	VDDIO	1	0x57	5b00101

2.7 Integration Guide

The AMx Ethernet Add-on Board ecosystem is not limited to the DP83867 Industrial Ethernet PHY. A wide variety of Industrial Ethernet PHYs with Arm-based processor compatible signals can be designed onto add-on boards to be used across different compatible EVMs. This section details the mechanical information and provide the necessary dimensions for designing an Industrial Ethernet PHY add-on board.

Note

All dimensions are measured in inches.

2.7.1 Board Dimensions

Figure 2-7 shows the proper PCB dimensions for an Industrial Ethernet PHY add-on board to be compatible with AMx EVMs.

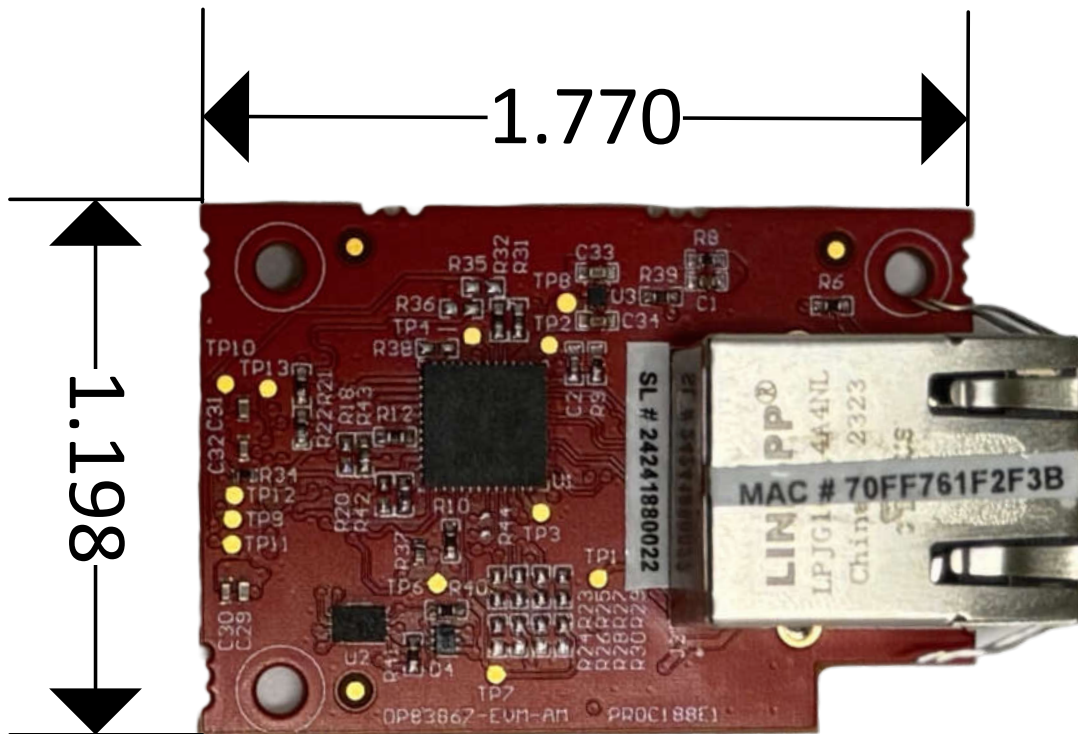

Figure 2-7. Industrial Ethernet PHY Add-on Board Dimensions

2.7.2 Installation

The Add-on board kit includes mounting hardware to install the board onto any compatible Arm-based processor EVMs.

The mounting hardware includes the following:

- 3x M3 Screws
- 3x plastic washers
- 3x metal nuts
- 3x plastic spacers

Below is the recommended method of mounting the add-on board:

1. Place the plastic washers on all screws
2. Place the screw with washers in the mounting holes of the add-on board
3. On the main EVM, place the plastic spacers on top of the main EVM mounting holes for the corresponding connector
4. Align the screws of the add-on board with the plastic spacers and main EVM mounting holes
5. Press down on the add-on board until there is an audible click signifying the connectors are flush
6. Thread the metal nuts on the underside of the main EVM on the screws until there is a secure connection between the add-on board and main EVM

Note

TI does *NOT* recommend mounting any Ethernet Add-on cards to the EVM without the mounting hardware. Doing so can cause damage to either or both boards.

3 Hardware Design Files

To download the zip file containing the latest design files for the EVM, go to the EVM product page on ti.com ([DP83867-EVM-AM](#)).

4 Additional Information

4.1 Known Hardware or Software Issues

This section describes the currently known issues on each EVM revision and applicable workarounds. Issues that have been patched have modification labels attached to the EVM assembly.

Table 4-1. DP83867-EVM-AM Known Issues and Modifications

Issue Number	Issue Title	Issue Description	Variants Affected
Issue 1	RGMII Boot Failure	RGMII booting fails when using the DP83867-EVM-AM Industrial PHY card.	A

4.1.1 Issue 1 - RGMII Boot Failure

Applicable EVM Revisions: A

Issue Description: RGMII booting fails when the DP83867-EVM-AM Industrial PHY Rev A card is used with the AUDIO-AM275-EVM/AUDIO-AM62D-EVM boards.

Note

This issue applies only during the RGMII boot process. During application execution, the software accesses the PHY through MDIO and programmatically configures the correct TX clock skew, thereby avoiding the double skew problem. Additionally, this timing issue is specific to 1000Mbps (Gigabit) link speed operation. At lower link speeds (10Mbps and 100Mbps), the RGMII TX clock timing margins are sufficient to tolerate the cumulative double clock skew, and booting succeeds without any hardware modification.

Root Cause: The DP83867-EVM-AM Industrial PHY Rev A card is configured through hardware strapping to apply a TX clock skew of 2ns on the PHY side. However, the AM62D/AM275 MAC interface already adds TX clock skew by default. This results in a cumulative double clock skew on the RGMII TX clock line, causing timing violations and boot failure.

Workaround: To mitigate this issue, The TX clock skew setting on the PHY card strapping must be changed from 2ns to 0ns, as the MAC side already compensates for the TX clock skew internally. Follow the steps below:

1. Remove any existing resistor populated on R23 of the DP83867-EVM-AM Industrial PHY Rev A card and mount a 10kΩ resistor on R23 of the Industrial PHY card.
2. Remove any existing resistor populated on R24 of the DP83867-EVM-AM Industrial PHY Rev A card and mount a 2.49kΩ resistor on R24 of the Industrial PHY card.

The following figure illustrates the resistor locations on the Industrial PHY card:

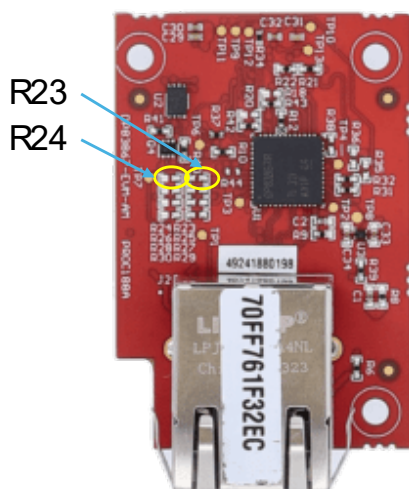

Figure 4-1. Industrial PHY Card

4.2 Trademarks

E2E™ is a trademark of Texas Instruments.

Arm® is a registered trademark of Arm Ltd.

All trademarks are the property of their respective owners.

5 References

5.1 Reference Documents

In addition to this document, the following references are available for download at www.ti.com.

- [AM275x Audio Evaluation Module Tool Folder](#)
- [AM62Dx Audio Evaluation Module Tool Folder](#)
- [DP83867IR Datasheet](#)
- [DP83867IR Product Folder](#)
- [Texas Instruments Code Composer Studio](#)

6 Revision History

Changes from Revision * (January 2025) to Revision A (July 2026)	Page
• Added <i>Known Issue</i> section.....	15
• Added Known Issue Section.....	15
• Added <i>Issue 1- RGMII Boot Failure</i> section and its workaround.....	15

STANDARD TERMS FOR EVALUATION MODULES

1. *Delivery:* TI delivers TI evaluation boards, kits, or modules, including any accompanying demonstration software, components, and/or documentation which may be provided together or separately (collectively, an "EVM" or "EVMs") to the User ("User") in accordance with the terms set forth herein. User's acceptance of the EVM is expressly subject to the following terms.
 - 1.1 EVMs are intended solely for product or software developers for use in a research and development setting to facilitate feasibility evaluation, experimentation, or scientific analysis of TI semiconductor products. EVMs have no direct function and are not finished products. EVMs shall not be directly or indirectly assembled as a part or subassembly in any finished product. For clarification, any software or software tools provided with the EVM ("Software") shall not be subject to the terms and conditions set forth herein but rather shall be subject to the applicable terms that accompany such Software
 - 1.2 EVMs are not intended for consumer or household use. EVMs may not be sold, sublicensed, leased, rented, loaned, assigned, or otherwise distributed for commercial purposes by Users, in whole or in part, or used in any finished product or production system.
2. *Limited Warranty and Related Remedies/Disclaimers:*
 - 2.1 These terms do not apply to Software. The warranty, if any, for Software is covered in the applicable Software License Agreement.
 - 2.2 TI warrants that the TI EVM will conform to TI's published specifications for ninety (90) days after the date TI delivers such EVM to User. Notwithstanding the foregoing, TI shall not be liable for a nonconforming EVM if (a) the nonconformity was caused by neglect, misuse or mistreatment by an entity other than TI, including improper installation or testing, or for any EVMs that have been altered or modified in any way by an entity other than TI, (b) the nonconformity resulted from User's design, specifications or instructions for such EVMs or improper system design, or (c) User has not paid on time. Testing and other quality control techniques are used to the extent TI deems necessary. TI does not test all parameters of each EVM. User's claims against TI under this Section 2 are void if User fails to notify TI of any apparent defects in the EVMs within ten (10) business days after delivery, or of any hidden defects with ten (10) business days after the defect has been detected.
 - 2.3 TI's sole liability shall be at its option to repair or replace EVMs that fail to conform to the warranty set forth above, or credit User's account for such EVM. TI's liability under this warranty shall be limited to EVMs that are returned during the warranty period to the address designated by TI and that are determined by TI not to conform to such warranty. If TI elects to repair or replace such EVM, TI shall have a reasonable time to repair such EVM or provide replacements. Repaired EVMs shall be warranted for the remainder of the original warranty period. Replaced EVMs shall be warranted for a new full ninety (90) day warranty period.

WARNING

Evaluation Kits are intended solely for use by technically qualified, professional electronics experts who are familiar with the dangers and application risks associated with handling electrical mechanical components, systems, and subsystems.

User shall operate the Evaluation Kit within TI's recommended guidelines and any applicable legal or environmental requirements as well as reasonable and customary safeguards. Failure to set up and/or operate the Evaluation Kit within TI's recommended guidelines may result in personal injury or death or property damage. Proper set up entails following TI's instructions for electrical ratings of interface circuits such as input, output and electrical loads.

NOTE:

EXPOSURE TO ELECTROSTATIC DISCHARGE (ESD) MAY CAUSE DEGRADATION OR FAILURE OF THE EVALUATION KIT; TI RECOMMENDS STORAGE OF THE EVALUATION KIT IN A PROTECTIVE ESD BAG.

3 Regulatory Notices:

3.1 United States

3.1.1 Notice applicable to EVMs not FCC-Approved:

FCC NOTICE: This kit is designed to allow product developers to evaluate electronic components, circuitry, or software associated with the kit to determine whether to incorporate such items in a finished product and software developers to write software applications for use with the end product. This kit is not a finished product and when assembled may not be resold or otherwise marketed unless all required FCC equipment authorizations are first obtained. Operation is subject to the condition that this product not cause harmful interference to licensed radio stations and that this product accept harmful interference. Unless the assembled kit is designed to operate under part 15, part 18 or part 95 of this chapter, the operator of the kit must operate under the authority of an FCC license holder or must secure an experimental authorization under part 5 of this chapter.

3.1.2 For EVMs annotated as FCC – FEDERAL COMMUNICATIONS COMMISSION Part 15 Compliant:

CAUTION

This device complies with part 15 of the FCC Rules. Operation is subject to the following two conditions: (1) This device may not cause harmful interference, and (2) this device must accept any interference received, including interference that may cause undesired operation.

Changes or modifications not expressly approved by the party responsible for compliance could void the user's authority to operate the equipment.

FCC Interference Statement for Class A EVM devices

NOTE: This equipment has been tested and found to comply with the limits for a Class A digital device, pursuant to part 15 of the FCC Rules. These limits are designed to provide reasonable protection against harmful interference when the equipment is operated in a commercial environment. This equipment generates, uses, and can radiate radio frequency energy and, if not installed and used in accordance with the instruction manual, may cause harmful interference to radio communications. Operation of this equipment in a residential area is likely to cause harmful interference in which case the user will be required to correct the interference at his own expense.

FCC Interference Statement for Class B EVM devices

NOTE: This equipment has been tested and found to comply with the limits for a Class B digital device, pursuant to part 15 of the FCC Rules. These limits are designed to provide reasonable protection against harmful interference in a residential installation. This equipment generates, uses and can radiate radio frequency energy and, if not installed and used in accordance with the instructions, may cause harmful interference to radio communications. However, there is no guarantee that interference will not occur in a particular installation. If this equipment does cause harmful interference to radio or television reception, which can be determined by turning the equipment off and on, the user is encouraged to try to correct the interference by one or more of the following measures:

- Reorient or relocate the receiving antenna.
- Increase the separation between the equipment and receiver.
- Connect the equipment into an outlet on a circuit different from that to which the receiver is connected.
- Consult the dealer or an experienced radio/TV technician for help.

3.2 Canada

3.2.1 For EVMs issued with an Industry Canada Certificate of Conformance to RSS-210 or RSS-247

Concerning EVMs Including Radio Transmitters:

This device complies with Industry Canada license-exempt RSSs. Operation is subject to the following two conditions:

(1) this device may not cause interference, and (2) this device must accept any interference, including interference that may cause undesired operation of the device.

Concernant les EVMs avec appareils radio:

Le présent appareil est conforme aux CNR d'Industrie Canada applicables aux appareils radio exempts de licence. L'exploitation est autorisée aux deux conditions suivantes: (1) l'appareil ne doit pas produire de brouillage, et (2) l'utilisateur de l'appareil doit accepter tout brouillage radioélectrique subi, même si le brouillage est susceptible d'en compromettre le fonctionnement.

Concerning EVMs Including Detachable Antennas:

Under Industry Canada regulations, this radio transmitter may only operate using an antenna of a type and maximum (or lesser) gain approved for the transmitter by Industry Canada. To reduce potential radio interference to other users, the antenna type and its gain should be so chosen that the equivalent isotropically radiated power (e.i.r.p.) is not more than that necessary for successful communication. This radio transmitter has been approved by Industry Canada to operate with the antenna types listed in the user guide with the maximum permissible gain and required antenna impedance for each antenna type indicated. Antenna types not included in this list, having a gain greater than the maximum gain indicated for that type, are strictly prohibited for use with this device.

Concernant les EVMs avec antennes détachables

Conformément à la réglementation d'Industrie Canada, le présent émetteur radio peut fonctionner avec une antenne d'un type et d'un gain maximal (ou inférieur) approuvé pour l'émetteur par Industrie Canada. Dans le but de réduire les risques de brouillage radioélectrique à l'intention des autres utilisateurs, il faut choisir le type d'antenne et son gain de sorte que la puissance isotrope rayonnée équivalente (p.i.r.e.) ne dépasse pas l'intensité nécessaire à l'établissement d'une communication satisfaisante. Le présent émetteur radio a été approuvé par Industrie Canada pour fonctionner avec les types d'antenne énumérés dans le manuel d'usage et ayant un gain admissible maximal et l'impédance requise pour chaque type d'antenne. Les types d'antenne non inclus dans cette liste, ou dont le gain est supérieur au gain maximal indiqué, sont strictement interdits pour l'exploitation de l'émetteur.

3.3 Japan

3.3.1 *Notice for EVMs delivered in Japan:* Please see http://www.tij.co.jp/lstds/ti_ja/general/eStore/notice_01.page 日本国内に輸入される評価用キット、ボードについては、次のところをご覧ください。

<https://www.ti.com/ja-jp/legal/notice-for-evaluation-kits-delivered-in-japan.html>

3.3.2 *Notice for Users of EVMs Considered "Radio Frequency Products" in Japan:* EVMs entering Japan may not be certified by TI as conforming to Technical Regulations of Radio Law of Japan.

If User uses EVMs in Japan, not certified to Technical Regulations of Radio Law of Japan, User is required to follow the instructions set forth by Radio Law of Japan, which includes, but is not limited to, the instructions below with respect to EVMs (which for the avoidance of doubt are stated strictly for convenience and should be verified by User):

1. Use EVMs in a shielded room or any other test facility as defined in the notification #173 issued by Ministry of Internal Affairs and Communications on March 28, 2006, based on Sub-section 1.1 of Article 6 of the Ministry's Rule for Enforcement of Radio Law of Japan,
2. Use EVMs only after User obtains the license of Test Radio Station as provided in Radio Law of Japan with respect to EVMs, or
3. Use of EVMs only after User obtains the Technical Regulations Conformity Certification as provided in Radio Law of Japan with respect to EVMs. Also, do not transfer EVMs, unless User gives the same notice above to the transferee. Please note that if User does not follow the instructions above, User will be subject to penalties of Radio Law of Japan.

【無線電波を送信する製品の開発キットをお使いになる際の注意事項】 開発キットの中には技術基準適合証明を受けていないものがあります。技術適合証明を受けていないものご使用に際しては、電波法遵守のため、以下のいずれかの措置を取っていただく必要がありますのでご注意ください。

1. 電波法施行規則第6条第1項第1号に基づく平成18年3月28日総務省告示第173号で定められた電波暗室等の試験設備でご使用いただく。
2. 実験局の免許を取得後ご使用いただく。
3. 技術基準適合証明を取得後ご使用いただく。

なお、本製品は、上記の「ご使用にあたっての注意」を譲渡先、移転先に通知しない限り、譲渡、移転できないものとします。

上記を遵守頂けない場合は、電波法の罰則が適用される可能性があることをご留意ください。日本テキサス・イ

ンスツルメンツ株式会社

東京都新宿区西新宿 6 丁目 2 4 番 1 号

西新宿三井ビル

3.3.3 *Notice for EVMs for Power Line Communication:* Please see http://www.tij.co.jp/lstds/ti_ja/general/eStore/notice_02.page

電力線搬送波通信についての開発キットをお使いになる際の注意事項については、次のところをご覧ください。 <https://www.ti.com/ja-jp/legal/notice-for-evaluation-kits-for-power-line-communication.html>

3.4 European Union

3.4.1 *For EVMs subject to EU Directive 2014/30/EU (Electromagnetic Compatibility Directive):*

This is a class A product intended for use in environments other than domestic environments that are connected to a low-voltage power-supply network that supplies buildings used for domestic purposes. In a domestic environment this product may cause radio interference in which case the user may be required to take adequate measures.

-
4. *EVM Use Restrictions and Warnings:*
 - 4.1 EVMS ARE NOT FOR USE IN FUNCTIONAL SAFETY AND/OR SAFETY CRITICAL EVALUATIONS, INCLUDING BUT NOT LIMITED TO EVALUATIONS OF LIFE SUPPORT APPLICATIONS.
 - 4.2 User must read and apply the user guide and other available documentation provided by TI regarding the EVM prior to handling or using the EVM, including without limitation any warning or restriction notices. The notices contain important safety information related to, for example, temperatures and voltages.
 - 4.3 *Safety-Related Warnings and Restrictions:*
 - 4.3.1 User shall operate the EVM within TI's recommended specifications and environmental considerations stated in the user guide, other available documentation provided by TI, and any other applicable requirements and employ reasonable and customary safeguards. Exceeding the specified performance ratings and specifications (including but not limited to input and output voltage, current, power, and environmental ranges) for the EVM may cause personal injury or death, or property damage. If there are questions concerning performance ratings and specifications, User should contact a TI field representative prior to connecting interface electronics including input power and intended loads. Any loads applied outside of the specified output range may also result in unintended and/or inaccurate operation and/or possible permanent damage to the EVM and/or interface electronics. Please consult the EVM user guide prior to connecting any load to the EVM output. If there is uncertainty as to the load specification, please contact a TI field representative. During normal operation, even with the inputs and outputs kept within the specified allowable ranges, some circuit components may have elevated case temperatures. These components include but are not limited to linear regulators, switching transistors, pass transistors, current sense resistors, and heat sinks, which can be identified using the information in the associated documentation. When working with the EVM, please be aware that the EVM may become very warm.
 - 4.3.2 EVMs are intended solely for use by technically qualified, professional electronics experts who are familiar with the dangers and application risks associated with handling electrical mechanical components, systems, and subsystems. User assumes all responsibility and liability for proper and safe handling and use of the EVM by User or its employees, affiliates, contractors or designees. User assumes all responsibility and liability to ensure that any interfaces (electronic and/or mechanical) between the EVM and any human body are designed with suitable isolation and means to safely limit accessible leakage currents to minimize the risk of electrical shock hazard. User assumes all responsibility and liability for any improper or unsafe handling or use of the EVM by User or its employees, affiliates, contractors or designees.
 - 4.4 User assumes all responsibility and liability to determine whether the EVM is subject to any applicable international, federal, state, or local laws and regulations related to User's handling and use of the EVM and, if applicable, User assumes all responsibility and liability for compliance in all respects with such laws and regulations. User assumes all responsibility and liability for proper disposal and recycling of the EVM consistent with all applicable international, federal, state, and local requirements.
 5. *Accuracy of Information:* To the extent TI provides information on the availability and function of EVMs, TI attempts to be as accurate as possible. However, TI does not warrant the accuracy of EVM descriptions, EVM availability or other information on its websites as accurate, complete, reliable, current, or error-free.
 6. *Disclaimers:*
 - 6.1 EXCEPT AS SET FORTH ABOVE, EVMS AND ANY MATERIALS PROVIDED WITH THE EVM (INCLUDING, BUT NOT LIMITED TO, REFERENCE DESIGNS AND THE DESIGN OF THE EVM ITSELF) ARE PROVIDED "AS IS" AND "WITH ALL FAULTS." TI DISCLAIMS ALL OTHER WARRANTIES, EXPRESS OR IMPLIED, REGARDING SUCH ITEMS, INCLUDING BUT NOT LIMITED TO ANY EPIDEMIC FAILURE WARRANTY OR IMPLIED WARRANTIES OF MERCHANTABILITY OR FITNESS FOR A PARTICULAR PURPOSE OR NON-INFRINGEMENT OF ANY THIRD PARTY PATENTS, COPYRIGHTS, TRADE SECRETS OR OTHER INTELLECTUAL PROPERTY RIGHTS.
 - 6.2 EXCEPT FOR THE LIMITED RIGHT TO USE THE EVM SET FORTH HEREIN, NOTHING IN THESE TERMS SHALL BE CONSTRUED AS GRANTING OR CONFERRING ANY RIGHTS BY LICENSE, PATENT, OR ANY OTHER INDUSTRIAL OR INTELLECTUAL PROPERTY RIGHT OF TI, ITS SUPPLIERS/LICENSORS OR ANY OTHER THIRD PARTY, TO USE THE EVM IN ANY FINISHED END-USER OR READY-TO-USE FINAL PRODUCT, OR FOR ANY INVENTION, DISCOVERY OR IMPROVEMENT, REGARDLESS OF WHEN MADE, CONCEIVED OR ACQUIRED.
 7. *USER'S INDEMNITY OBLIGATIONS AND REPRESENTATIONS.* USER WILL DEFEND, INDEMNIFY AND HOLD TI, ITS LICENSORS AND THEIR REPRESENTATIVES HARMLESS FROM AND AGAINST ANY AND ALL CLAIMS, DAMAGES, LOSSES, EXPENSES, COSTS AND LIABILITIES (COLLECTIVELY, "CLAIMS") ARISING OUT OF OR IN CONNECTION WITH ANY HANDLING OR USE OF THE EVM THAT IS NOT IN ACCORDANCE WITH THESE TERMS. THIS OBLIGATION SHALL APPLY WHETHER CLAIMS ARISE UNDER STATUTE, REGULATION, OR THE LAW OF TORT, CONTRACT OR ANY OTHER LEGAL THEORY, AND EVEN IF THE EVM FAILS TO PERFORM AS DESCRIBED OR EXPECTED.

8. *Limitations on Damages and Liability:*

8.1 *General Limitations.* IN NO EVENT SHALL TI BE LIABLE FOR ANY SPECIAL, COLLATERAL, INDIRECT, PUNITIVE, INCIDENTAL, CONSEQUENTIAL, OR EXEMPLARY DAMAGES IN CONNECTION WITH OR ARISING OUT OF THESE TERMS OR THE USE OF THE EVMS , REGARDLESS OF WHETHER TI HAS BEEN ADVISED OF THE POSSIBILITY OF SUCH DAMAGES. EXCLUDED DAMAGES INCLUDE, BUT ARE NOT LIMITED TO, COST OF REMOVAL OR REINSTALLATION, ANCILLARY COSTS TO THE PROCUREMENT OF SUBSTITUTE GOODS OR SERVICES, RETESTING, OUTSIDE COMPUTER TIME, LABOR COSTS, LOSS OF GOODWILL, LOSS OF PROFITS, LOSS OF SAVINGS, LOSS OF USE, LOSS OF DATA, OR BUSINESS INTERRUPTION. NO CLAIM, SUIT OR ACTION SHALL BE BROUGHT AGAINST TI MORE THAN TWELVE (12) MONTHS AFTER THE EVENT THAT GAVE RISE TO THE CAUSE OF ACTION HAS OCCURRED.

8.2 *Specific Limitations.* IN NO EVENT SHALL TI'S AGGREGATE LIABILITY FROM ANY USE OF AN EVM PROVIDED HEREUNDER, INCLUDING FROM ANY WARRANTY, INDEMNITY OR OTHER OBLIGATION ARISING OUT OF OR IN CONNECTION WITH THESE TERMS, , EXCEED THE TOTAL AMOUNT PAID TO TI BY USER FOR THE PARTICULAR EVM(S) AT ISSUE DURING THE PRIOR TWELVE (12) MONTHS WITH RESPECT TO WHICH LOSSES OR DAMAGES ARE CLAIMED. THE EXISTENCE OF MORE THAN ONE CLAIM SHALL NOT ENLARGE OR EXTEND THIS LIMIT.

9. *Return Policy.* Except as otherwise provided, TI does not offer any refunds, returns, or exchanges. Furthermore, no return of EVM(s) will be accepted if the package has been opened and no return of the EVM(s) will be accepted if they are damaged or otherwise not in a resalable condition. If User feels it has been incorrectly charged for the EVM(s) it ordered or that delivery violates the applicable order, User should contact TI. All refunds will be made in full within thirty (30) working days from the return of the components(s), excluding any postage or packaging costs.

10. *Governing Law:* These terms and conditions shall be governed by and interpreted in accordance with the laws of the State of Texas, without reference to conflict-of-laws principles. User agrees that non-exclusive jurisdiction for any dispute arising out of or relating to these terms and conditions lies within courts located in the State of Texas and consents to venue in Dallas County, Texas. Notwithstanding the foregoing, any judgment may be enforced in any United States or foreign court, and TI may seek injunctive relief in any United States or foreign court.

Mailing Address: Texas Instruments, Post Office Box 655303, Dallas, Texas 75265
Copyright © 2023, Texas Instruments Incorporated

IMPORTANT NOTICE AND DISCLAIMER

TI PROVIDES TECHNICAL AND RELIABILITY DATA (INCLUDING DATASHEETS), DESIGN RESOURCES (INCLUDING REFERENCE DESIGNS), APPLICATION OR OTHER DESIGN ADVICE, WEB TOOLS, SAFETY INFORMATION, AND OTHER RESOURCES "AS IS" AND WITH ALL FAULTS, AND DISCLAIMS ALL WARRANTIES, EXPRESS AND IMPLIED, INCLUDING WITHOUT LIMITATION ANY IMPLIED WARRANTIES OF MERCHANTABILITY, FITNESS FOR A PARTICULAR PURPOSE OR NON-INFRINGEMENT OF THIRD PARTY INTELLECTUAL PROPERTY RIGHTS.

These resources are intended for skilled developers designing with TI products. You are solely responsible for (1) selecting the appropriate TI products for your application, (2) designing, validating and testing your application, and (3) ensuring your application meets applicable standards, and any other safety, security, regulatory or other requirements.

These resources are subject to change without notice. TI grants you permission to use these resources only for development of an application that uses the TI products described in the resource. Other reproduction and display of these resources is prohibited. No license is granted to any other TI intellectual property right or to any third party intellectual property right. TI disclaims responsibility for, and you fully indemnify TI and its representatives against any claims, damages, costs, losses, and liabilities arising out of your use of these resources.

TI's products are provided subject to [TI's Terms of Sale](#), [TI's General Quality Guidelines](#), or other applicable terms available either on [ti.com](#) or provided in conjunction with such TI products. TI's provision of these resources does not expand or otherwise alter TI's applicable warranties or warranty disclaimers for TI products. Unless TI explicitly designates a product as custom or customer-specified, TI products are standard, catalog, general purpose devices.

TI objects to and rejects any additional or different terms you may propose.

Copyright © 2026, Texas Instruments Incorporated

Last updated 10/2025