

# High-current voltage output circuit using a precision DAC

Uttama Kumar Sahu

## Design Goals

Power Supply	DAC Output	Voltage Output	Current Output
VCC: 24V, VSS: –5V, VDD: 5V	0V to 2.5V	0V to 5V	0A to 10A

## Design Description

High-current voltage output can be obtained from a digital-to-analog converter (DAC) using a power amplifier at the DAC output. To have additional flexibility with amplifier performance like accuracy, bandwidth, and higher current, the circuit as shown in the following figure is more suitable. For example, power amplifiers typically have much higher output offset error compared to a precision amplifier. The DAC programs the output voltage along with the gain of the amplifier. The amplifier maintains the output voltage using negative feedback. The high current to the load is provided by the transistor. This circuit is useful in applications where components must be tested with different AC or DC voltage excitation such as [memory and semiconductor test equipment](#), [LCD test equipment](#), and others.

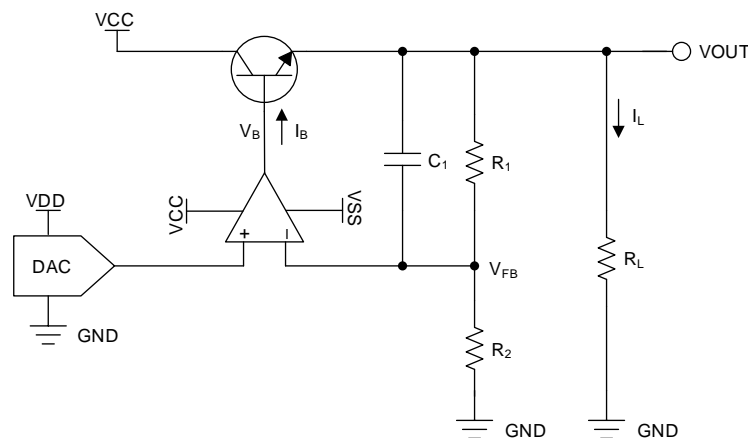

## Design Notes

1. Choose a DAC with the required resolution and output range.
2. Choose an op amp with low offset and low drift to minimize error. Choose a part with sufficient gain-bandwidth product (GBW), as required by the output signal.
3. Choose  $R_1$  and  $R_2$  such that the desired output voltage is met along with the DAC output voltage, along with tolerance which maintains the desired accuracy.
4. Choose the compensation capacitor  $C_1$  such that it is larger than the input capacitance of the op-amp inputs.
5. Choose a transistor that can provide the required load current and has a high  $h_{FE}$  so that the base current is sufficiently smaller than the output current limit of the op amp. A bipolar-junction transistor (BJT) Darlington pair or a high-power metal-oxide semiconductor field-effect transistor (MOSFET) are preferable.

## Design Steps

1. The DAC80501 device is a 16-bit, single-channel, high-performance precision DAC. The DAC80501 device is specified monotonic, by design, and offers excellent linearity of less than 1LSB. These devices include a 2.5V, 5ppm/°C internal reference, giving full-scale output voltage ranges of 1.25V, 2.5V, or 5V.
2. The OPA227 operational amplifier combines low noise and wide bandwidth with high precision to make it the ideal choice for applications requiring both AC and precision DC performance. The OPA227 device is unity-gain stable and features high slew rate (2.3V/μs) and wide bandwidth (8MHz).
3. The transfer function of the output voltage is given by:

$$V_{\text{OUT}} = V_{\text{DAC}} \left( 1 + \frac{R_1}{R_2} \right)$$

To get an output voltage of 5V with a DAC output of 2.5V, for example, chose both  $R_1$  and  $R_2$  as 10kΩ. This keeps the quiescent current through the feedback network as  $5V / 20k\Omega = 250\mu A$ . This current works for this design because this design is for a high-output current. In case the output current is lower, the resistance values can be increased so that the quiescent current is negligible, compared to the output current.

4. The base current,  $I_B$ , for the transistor for a given load current  $I_L$  is given by:

$$I_B = \frac{I_C}{h_{FE}} = \frac{1}{h_{FE}} \left( I_L + \left( \frac{V_{\text{OUT}}}{R_1 + R_2} \right) \right)$$

To get a maximum load current of 10A, the collector current ( $I_C$ ) of the transistor is approximately 10A (ignoring 250-μA quiescent current). To keep  $I_B$  less than 20mA,  $h_{FE}$  should be greater than  $(10A / 20mA) = 500$

5. In general, compensation capacitor  $C_1$  is not set by fixed equations, but rather by choosing values while observing the output small-signal step response. Through simulation in this example, select  $C_1 \geq 22pF$ .

## DC Transfer Characteristics

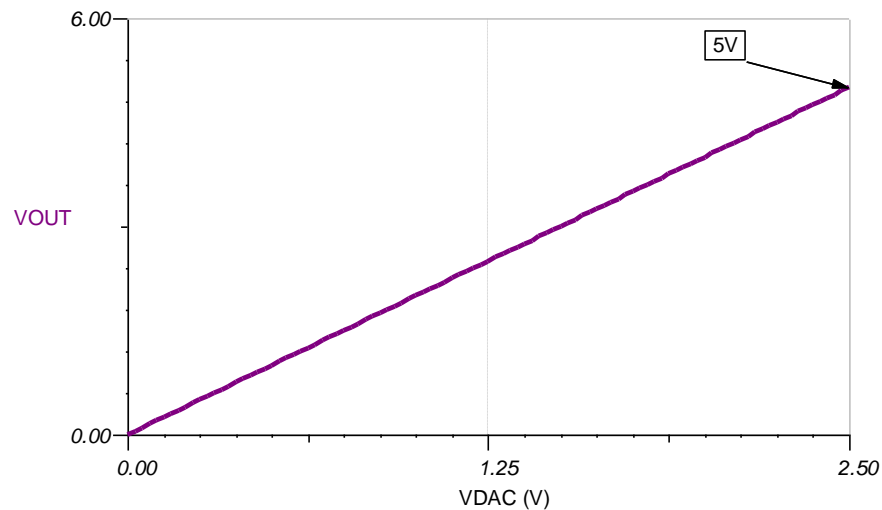

### Small Signal Step Response Without Compensation

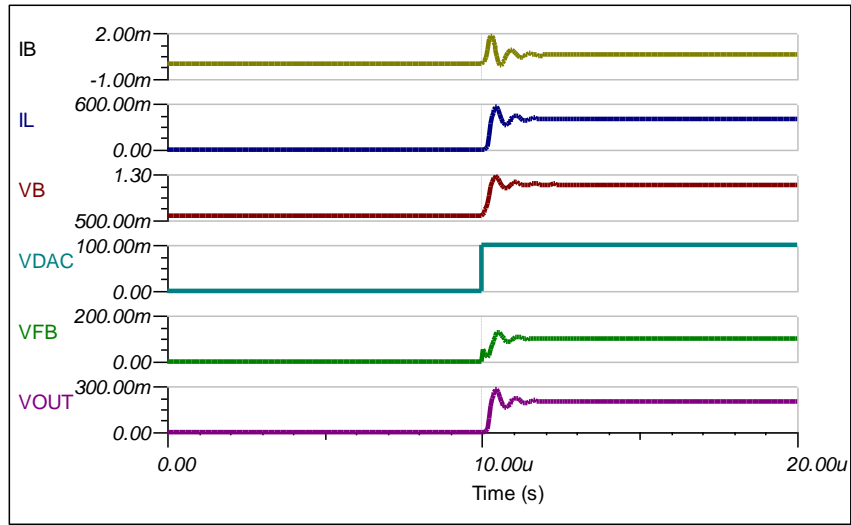

### Small Signal Step Response With $C_1 = 22\text{pF}$

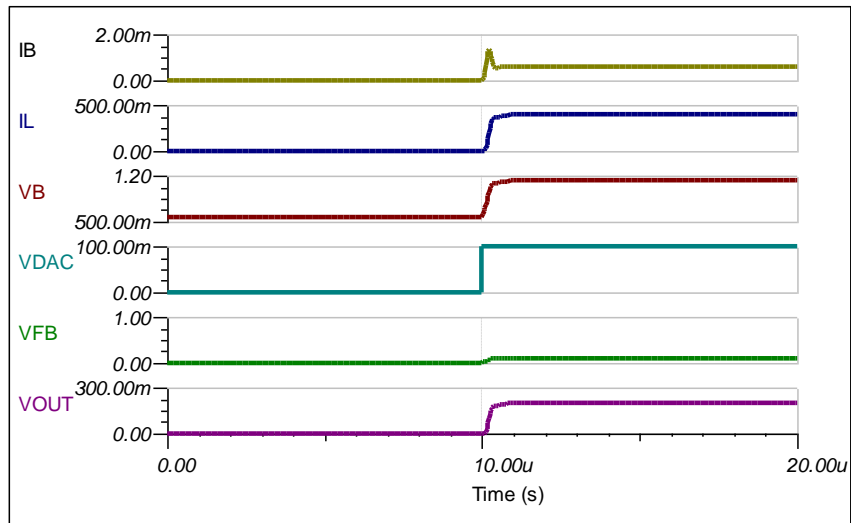

## Alternative Design With Power Amplifier

The following figure depicts the simplified circuit diagram of an alternative design using a power amplifier. To achieve a high-current output from the DAC, use a power amplifier like the OPA541 device. However, as previously mentioned, this circuit may have accuracy and bandwidth limitations. Depending on the system requirements, either of the circuit topologies can be used for generating high-current output. The output transfer function of this circuit is the same as the following figure.

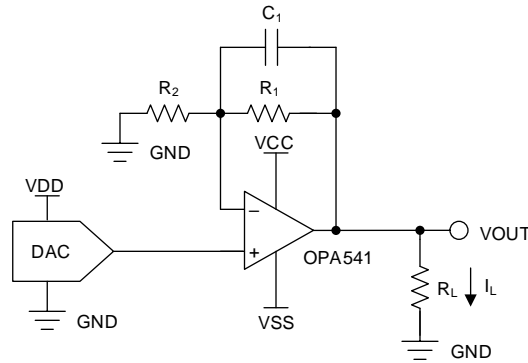

## Design Featured Devices and Alternative Parts

Device	Key Features	Link
DAC80501	16-bit, 1-LSB INL, digital-to-analog converter (DAC) with precision internal reference	<a href="http://www.ti.com/product/DAC80501">http://www.ti.com/product/DAC80501</a>
DAC8551	16-Bit, ultra-low glitch, voltage output, digital-to-analog converter	<a href="http://www.ti.com/product/DAC8551">http://www.ti.com/product/DAC8551</a>
DAC8811	16-bit, single-channel, serial input multiplying DAC with 0.5- $\mu$ s settling time	<a href="http://www.ti.com/product/DAC8811">http://www.ti.com/product/DAC8811</a>
DAC8831	16-bit, ultra-low power, voltage output digital-to-analog converter	<a href="http://www.ti.com/product/DAC8831">http://www.ti.com/product/DAC8831</a>
OPA227	High Precision, Low Noise Operational Amplifiers	<a href="http://www.ti.com/product/OPA227">http://www.ti.com/product/OPA227</a>
OPA541	High Power Monolithic Operational Amplifier	<a href="http://www.ti.com/product/OPA541">http://www.ti.com/product/OPA541</a>
THS4011	290-MHz low-distortion voltage-feedback amplifier	<a href="http://www.ti.com/product/THS4011">http://www.ti.com/product/THS4011</a>

## Design References

See [Analog Engineer's Circuit Cookbooks](#) for TI's comprehensive circuit library.

### Link to Key Files

TINA source files – <http://www.ti.com/lit/zip/sbam417>.

For direct support from TI Engineers use the E2E community

[e2e.ti.com](http://e2e.ti.com)

## IMPORTANT NOTICE AND DISCLAIMER

TI PROVIDES TECHNICAL AND RELIABILITY DATA (INCLUDING DATA SHEETS), DESIGN RESOURCES (INCLUDING REFERENCE DESIGNS), APPLICATION OR OTHER DESIGN ADVICE, WEB TOOLS, SAFETY INFORMATION, AND OTHER RESOURCES "AS IS" AND WITH ALL FAULTS, AND DISCLAIMS ALL WARRANTIES, EXPRESS AND IMPLIED, INCLUDING WITHOUT LIMITATION ANY IMPLIED WARRANTIES OF MERCHANTABILITY, FITNESS FOR A PARTICULAR PURPOSE OR NON-INFRINGEMENT OF THIRD PARTY INTELLECTUAL PROPERTY RIGHTS.

These resources are intended for skilled developers designing with TI products. You are solely responsible for (1) selecting the appropriate TI products for your application, (2) designing, validating and testing your application, and (3) ensuring your application meets applicable standards, and any other safety, security, regulatory or other requirements.

These resources are subject to change without notice. TI grants you permission to use these resources only for development of an application that uses the TI products described in the resource. Other reproduction and display of these resources is prohibited. No license is granted to any other TI intellectual property right or to any third party intellectual property right. TI disclaims responsibility for, and you will fully indemnify TI and its representatives against, any claims, damages, costs, losses, and liabilities arising out of your use of these resources.

TI's products are provided subject to [TI's Terms of Sale](#) or other applicable terms available either on [ti.com](http://ti.com) or provided in conjunction with such TI products. TI's provision of these resources does not expand or otherwise alter TI's applicable warranties or warranty disclaimers for TI products.

TI objects to and rejects any additional or different terms you may have proposed.

Mailing Address: Texas Instruments, Post Office Box 655303, Dallas, Texas 75265  
Copyright © 2021, Texas Instruments Incorporated