

THERE'S A WORLD OF LINE DRIVERS TO CHOOSE FROM

By Christian Henn, and Ernst Rau, Burr-Brown International GmbH

Coax cables with a typical impedance of 50Ω or 75Ω are used in many applications to ensure signal fidelity, and high-speed line drivers have the often difficult job of transmitting signals over these cables or over twisted pair lines. The most common way to drive coax cables is to use driver amplifiers with low-impedance voltage output, which operate with either voltage or current feedback. Now, however, the wideband OTAs, OPA660 and OPA2662, offer a high-impedance current output, giving engineers more flexibility and more options. Since both voltage and current outputs have their advantages and disadvantages, engineers can choose the method that provides the best compromise for their applications.

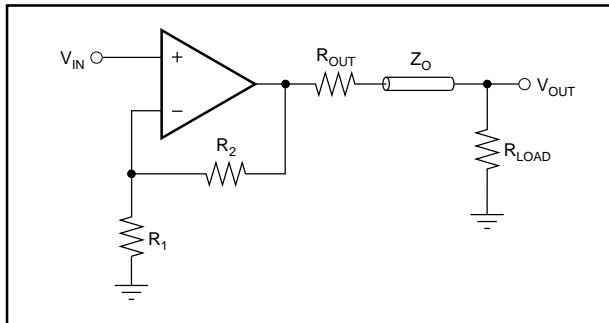

FIGURE 1. Typical Line Driver Circuit.

WIDE-BAND OPERATIONAL AMPLIFIERS OPA660 AND OPA2662

The OPA660 was used in open-loop, direct-feedback, and current-feedback modes to implement different voltage drive configurations. The open-loop buffer amplifier, BUF601, located behind the OPA660 in the circuit, decouples the high-impedance OTA collector output and provides a low-impedance voltage source output to drive the transmission line or bus system. The OPA660 contains the so-called Diamond Transistor (DT) and a buffer amplifier called the Diamond Buffer (DB) in an 8-pin plastic package. The buffer amplifier input is connected to GND in all three versions and compensates the input offset voltage of the OTA. As indicated in the PDS, the drive capability of the BUF601 is ±20mA for continuous current but can easily go up to ±50mA for pulse applications.

The OPA2662 contains two OTAs in a 16-pin plastic package; each can deliver output current of ±75mA. By connecting the two collector outputs, it is possible to increase the current drive capability to ±150mA. For the current drive concept, the OPA2662 operates in open-loop mode and in a

direct-feedback configuration. One special feature of the OPA2662 is its ability to switch the EN inputs of the OTAs independently; the OTAs can be switched on within 30ns and off within 250ns at maximum output power.

THE BASIC FACTS ABOUT A LOW-IMPEDANCE TRANSMISSION LINE

The most important equations and technical basics of transmission lines support the results found for the various drive circuits presented here. An ideal transmission medium with zero ohmic impedance would have inductance and capacitance distributed over the transmission cable. Both inductance and capacitance detract from the transmission quality of a line. Each input is connected with high impedance to the line as in a daisy chain or loop-through configuration, and each adds capacitance of at least a few picofarad. The typical transmission line impedance (Z_0) defines the line type. In equation (1), the impedance is calculated by the square root of line inductance (L_T) divided by line capacitance (C_T):

$$Z_0 = \sqrt{\frac{L_T}{C_T}} \quad (1)$$

In the same manner, line inductance and capacitance determine the delay time of a transmission line as shown in equation (2):

$$T = \sqrt{L_T \cdot C_T} \quad (2)$$

Typical values for Z_0 are 240Ω for symmetrical lines and 75Ω or 50Ω for coax cables. Z_0 sometimes decreases to 30Ω to 40Ω in high data rate bus systems for bus lines on printed circuit boards. In general, the more complex a bus system is, the lower Z_0 will be. Because it increases the capacitance of the transmission medium, a complex system lowers the typical line impedance, resulting in higher drive requirements for the line drivers used here.

Transmission lines are almost always terminated on the transmitter line and always terminated on the receiver side. Unterminated lines generate signal reflections that degrade the pulse fidelity. The driver circuit transmits the output voltage (V_{OUT}) over the line. The signal appears at the end of the line and will be reflected when not properly terminated. The reflected portion of V_{OUT} , called V_{REFL} , returns to the driver. The transmitted signal is the sum of the original signal V_{OUT} and the reflected V_{REFL} .

$$V_T = V_{OUT} + V_{REFL} \quad (3)$$

The magnitude of the reflected signal depends upon the typical line impedance (Z_0) and the value of the termination resistor Z_1 .

$$V_{\text{REFL}} = V_{\text{OUT}} \cdot \phi \quad (4)$$

ϕ denotes the reflection factor and is described by Equation 5.

$$\phi = \left(\frac{Z_1 - Z_0}{Z_1 + Z_0} \right) \quad (5)$$

ϕ can vary from -1 to $+1$.

The conditions at the corner points of Equation 5 are as follows:

$Z_0 = Z_1$	\rightarrow	$\phi = 0$	$V_{\text{REFL}} = 0$
$Z_0 = \infty$	\rightarrow	$\phi = -1$	$V_{\text{REFL}} = -V_{\text{OUT}}$
$Z_0 = 0$	\rightarrow	$\phi = +1$	$V_{\text{REFL}} = +V_{\text{OUT}}$

An unterminated driver circuit complicates the situation even more. V_{REFL} is reflected a second time on the driver side and wanders like a ping-pong ball back and forth over the line. When this happens, it is usually impossible to recover the output signal V_{OUT} on the receiver side.

OP AMPS AS LINE DRIVERS

Most transmission systems use voltage- or current-feedback op amps as line drivers. The output of the feedback system drives both the line and the feedback network, which has to be low-impedance for a wide frequency response, especially for current-feedback op amps. The double drive requirements raise the output current and lower the achievable bandwidth.

Nowadays, complementary bipolar processes for $\pm 5\text{V}$ supplies are being used for high-speed op amp designs. The $\pm 5\text{V}$ supply limits the linear output voltage range of the op amp output to about $\pm 3\text{V}$. In a double-terminated system, the maximum voltage drop across the load resistor decreases to $\pm 1.5\text{V}$, because it forms a 1-by-1 voltage divider with the

termination resistor in series to the driver output. The current concept allows the voltage drop to increase to $\pm 3\text{V}$ over the load and back-termination resistors, as will be shown later. The output impedance of feedback systems is in the $\text{m}\Omega$ range for low frequencies. When the open-loop gain of the op amp starts to roll off, the output impedance rises to 20Ω to 30Ω at 100MHz . This imperfect termination causes high-frequency signals to be reflected. The output impedance of open-loop buffer amplifiers is higher, but it stays constant over a wider frequency range. In addition, it is easy to compensate for the higher output impedance by slightly reducing the termination resistor value since

$$Z_0 = Z_{\text{OUT}} + Z_T \quad (6)$$

As has already been discussed in several other application notes, the delay time of the op amp feedback loop determines the minimum rise and fall times of the input signal to be processed. When the rise time is approximately three times the delay time, the output usually has less edge sloping, less overshooting and shorter settling times. All of the current drivers and most of the voltage drivers proposed here succeed in at least partly achieving these parameters, while offering excellent pulse responses down to 1ns .

VOLTAGE DRIVER CONCEPTS

Open-Loop Amplifier

The circuit schematic of the open-loop amplifier consisting of an OPA660 followed by a BUF601 as line driver is illustrated in Figure 2.

The performance of this open-loop configuration is not influenced by the delay time. The amplifier operates at a gain of $+6\text{V/V}$ and amplifies the 1Vp-p input voltage to 6Vp-p output voltage. As shown in Figure 3, a line driver with a transmission line terminated on both sides achieves a bandwidth of 460MHz at 1.4Vp-p and 375MHz at 2.8Vp-p . Table I summarizes the parameters for bandwidth, rise and fall time, and harmonic distortion for all of the driver circuits presented here.

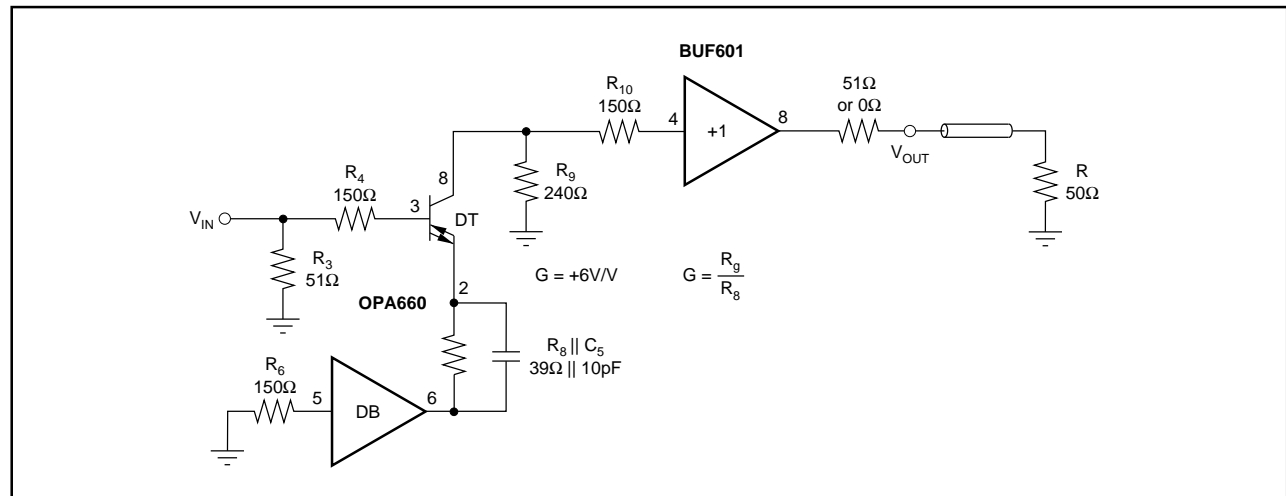

FIGURE 2. Schematic of the Open-Loop Amplifier.

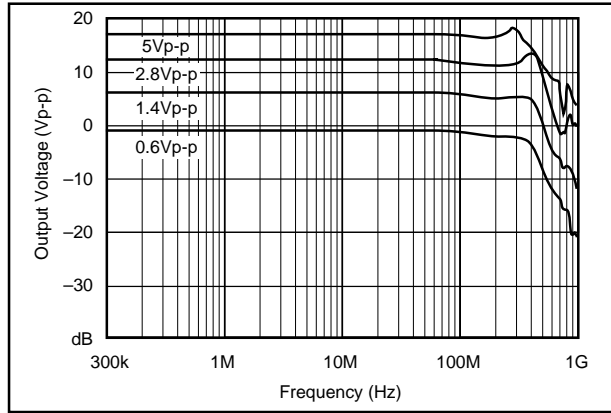

FIGURE 3. Frequency Response of the Open-Loop Amplifier.

	VOLTAGE MODE			CURRENT MODE		
	OLA	DFA	CFA	OLA	DFA ⁽¹⁾	UNITS
Bandwidth						
0.6Vp-p	375	416	366	307	262	MHz
2.8Vp-p	460	580	510	287	184	MHz
5Vp-p	375	370	317	156	140	MHz
t_{RISE}	1.4	1.5	1.6	3.1	2.5	ns
t_{FALL}	2.6	1.5	1.9	4.7	7.4	ns
Harmonic Distortion						
2nd, 10MHz, 4Vp-p	-44.5	-45.5	-49.7	-31.3	-31.6	dBc
R_{LOAD} Total	100	100	100	25	25	Ω

NOTE: (1) OLA = Open-Loop Amplifier, DFA = Direct-Feedback Amplifier, CFA = Current-Feedback Amplifier.

TABLE I. Performance of Line Drivers on a Double-Terminated Line.

Direct Feedback Amplifier

Figure 4 presents the direct-feedback configuration of the amplifier, which also uses the BUF601 as a line driver.

As illustrated in Figure 5 for $R_{LOAD} = 100\Omega$, the bandwidth can be increased to 580MHz at 2.8Vp-p and 370MHz at 5Vp-p. The buffer amplifier limits the maximum output voltage, however, to 6Vp-p.

In all three voltage drive circuits, the OPA660 is adjusted to a $\pm 20\text{mA}$ quiescent current and the BUF601 consumes only $\pm 6\text{mA}$.

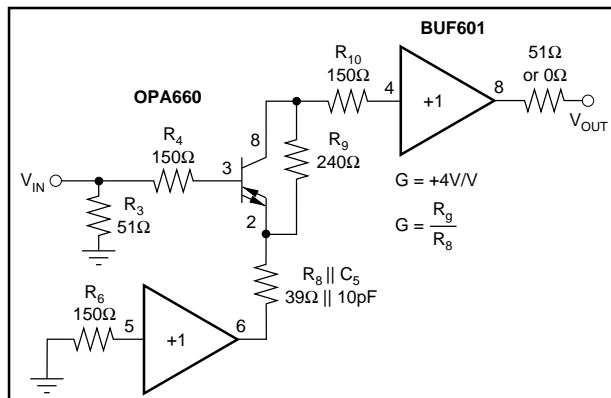

FIGURE 4. Schematic of the Direct-Feedback Amplifier.

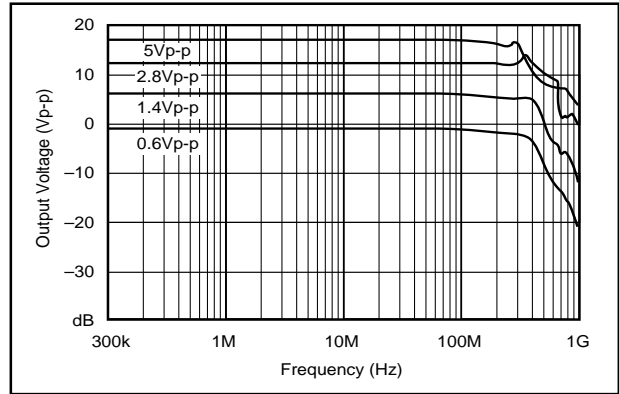

FIGURE 5. Frequency Response of the Direct-Feedback Amplifier.

Current-Feedback Amplifier

Figure 6 presents an offset-compensated current-feedback amplifier with two identical high-impedance inputs. The BUF601 is part of the feedback loop. The noninverting version achieves 514MHz at 1.4Vp-p and 317MHz at 2.8Vp-p. The results of the bandwidth measurements are shown in Figure 7.

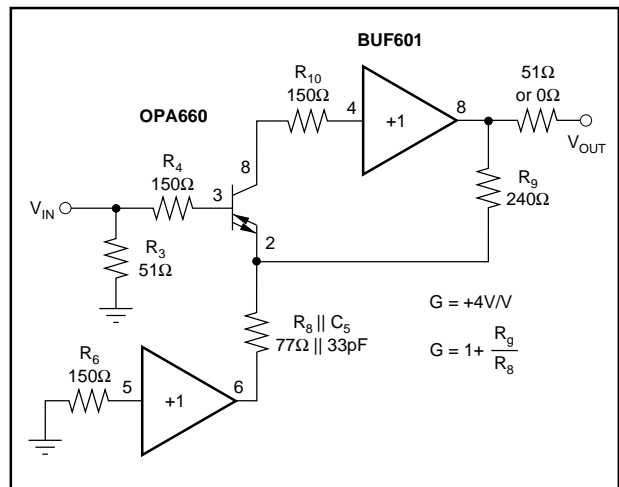

FIGURE 6. Schematic of the Current-Feedback Amplifier.

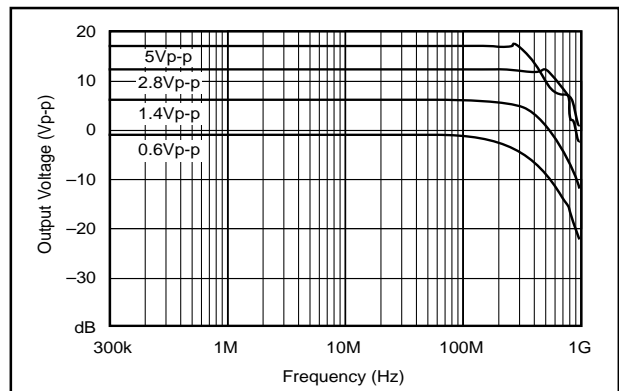

FIGURE 7. Frequency Response of the Current-Feedback Amplifier.

CURRENT DRIVE CONCEPTS

Open-Loop Current Driver

It is easy to see that the termination resistor in series to the transmission line is responsible for the reduced maximum voltage drop across the load resistor. A driver circuit consisting of a high-impedance current source as shown in Figure 8, however, can raise the voltage drop even for a double-terminated line when the OTA is capable of driving two parallel 50Ω resistors at 6Vp-p. In this configuration, the current driver supplies 240mA_{p-p} output current into the load resistors. When the 10Ω resistor in series to ±V_{CCOUT} is bridged, the maximum voltage compliance at the current source output reaches about 6.8Vp-p. The two OTAs are connected together in order to increase the total drive capability to 300mA_{p-p}. C_E parallel to R_E compensates for the unfavorable capacitance at the collector output. The total quiescent current for both OTAs has been set to ±17mA. The gain is adjusted by the following formula:

$$G = \frac{V_{OUT}}{V_{IN}} = \frac{3R_C}{R_E} \quad (7)$$

As shown in Figure 9, the circuit presented in this section achieves a bandwidth of 156MHz at an output voltage of 5Vp-p across the load resistor and a bandwidth of 287MHz at 2.8Vp-p.

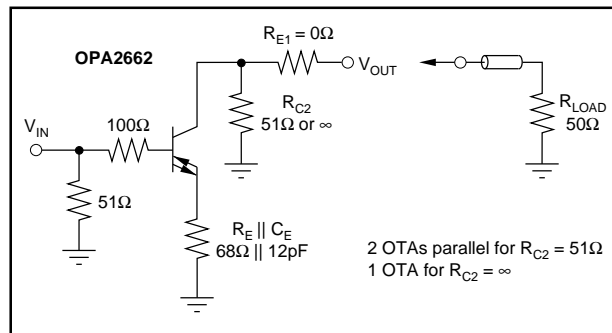

FIGURE 8. Schematic of the Open-Loop Current Driver.

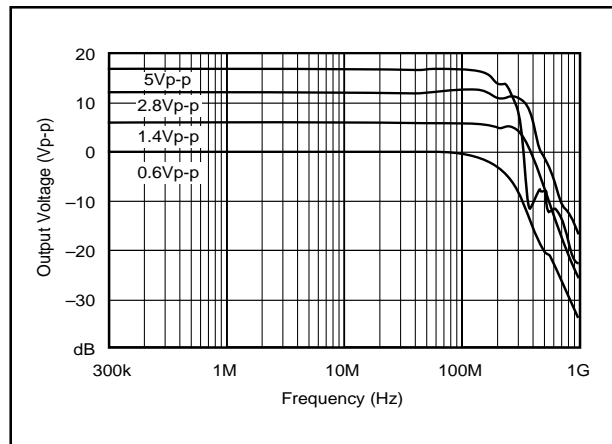

FIGURE 9. Frequency Response of the Open-Loop Current Driver.

CURRENT-DRIVER IN DIRECT-FEEDBACK MODE

As already demonstrated, the OTAs show excellent pulse responses in the direct-feedback mode. The short feedback loop from collector to emitter eases the design and improves the circuit's stability over parameter variation. The values achieved for the bandwidth, rise and fall times, and harmonic distortion of the drive circuit in Figure 10 are not included in Table I. Figure 11 contains frequency response curves for 0.6Vp-p, 2.8Vp-p, and 5Vp-p across the load resistor.

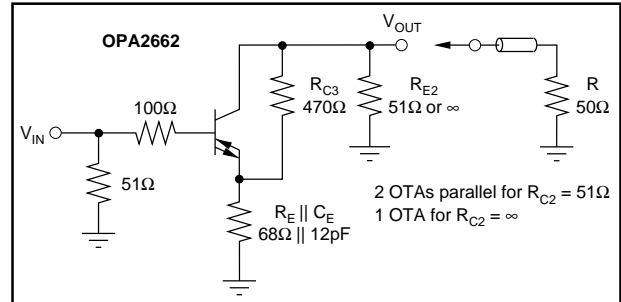

FIGURE 10. Schematic of the Direct-Feedback Current Driver.

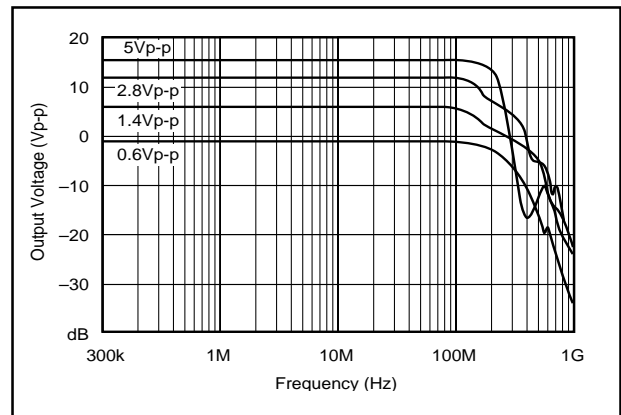

FIGURE 11. Frequency Response of the Direct-Feedback Current Driver.

Two disadvantages for the achievable bandwidth and rise times of the current driver concept are the high current required for double termination and the relatively high effective capacitance at the impedance output. The high output impedance and the capacitance form a low pass, which reduces the bandwidth to about 200MHz. Another way to overcome the doubled output capacitance of the parallel OTAs is to use a 50Ω output impedance in the feedback network to the emitter. This concept is too complicated to explain here in detail and will be covered in a separate Application Note.

Proper termination of the transmission lines on the load resistor side prevents signal reflections, enabling even voltage drivers to provide a 6Vp-p voltage drop across the load resistors. With this ability, voltage drivers can outperform current drivers in many parameters.

The test results for a total load resistance of 50Ω for voltage and current concepts are summarized in Table II. At a load resistance of 50Ω , a single OTA can handle the current even at an output voltage of $6.8V_{p-p}$. Finally, the large-signal pulse response shown in Figure 12 for the direct-feedback driver in voltage mode demonstrates the drive capabilities of the OPA660 and BUF601.

	VOLTAGE MODE			CURRENT MODE		
	OLA	DFA	CFA	OLA	DFA ⁽¹⁾	UNITS
Bandwidth						
0.6Vp-p	365	419	334	320	320	MHz
2.8Vp-p	490	462	448	312	270	MHz
5Vp-p	332	326	276	201	173	MHz
t_{RISE}	1.7	1.6	1.6	2.6	2.2	ns
t_{FALL}	2.5	2.3	2.2	6.0	5.7	ns
Harmonic Distortion						
2nd, 10MHz, 4Vp-p	-48	-49.5	-50.5	-31.4	-31	dBc
R_{LOAD} Total	50	50	50	50	50	Ω

NOTE: (1) OLA = Open-Loop Amplifier, DFA = Direct-Feedback Amplifier, CFA = Current-Feedback Amplifier.

TABLE II. Performance of Line Drivers on a Single-Terminated Line.

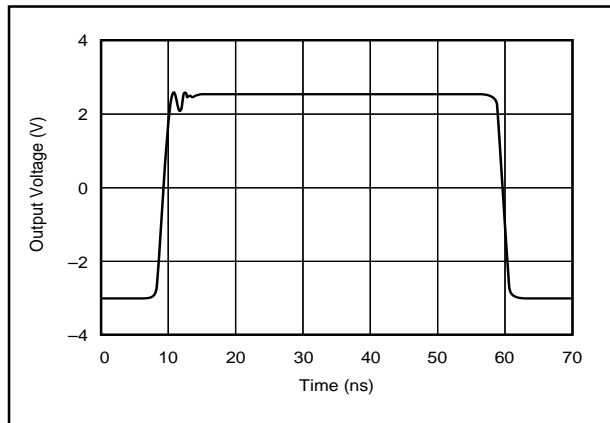

FIGURE 12. Large-Signal Pulse Response of the Direct-Feedback Amplifier.

The above tests have shown that for applications in which bandwidth is the highest requirement, the voltage concept has proven itself the best method as long as the maximum voltage across a load resistor does not exceed $3V_{p-p}$ for $\pm 5V$ op amps. A voltage range of more than $3V_{p-p}$ requires op amps with $\pm 15V$ supply, however, and currently there are no $\pm 15V$ op amps that can handle frequencies up to $500MHz$. With $200MHz$ bandwidth, rise/fall times around $5ns$, and a $6V_{p-p}$ voltage drop across the load, driver circuits with the OPA2662 provide more drive capability than a $\pm 15V$ op amp, while significantly improving power consumption. A comparison of the frequency responses of the line driver concepts presented here shows that the current concepts roll off slightly, while the voltage concepts have a peaking tendency at the end of the passband. Current output drivers thus prevent excessive peaking and improve stability when driving very long coax cables with high stray capacitances.

The excellent drive quality and output current capability of the OPA2662 and BUF601 are evidenced in the results in Tables I and II. The achieved parameters for bandwidth, rise and fall times, and harmonic distortion differ slightly for the two kinds of termination.

IMPORTANT NOTICE

Texas Instruments and its subsidiaries (TI) reserve the right to make changes to their products or to discontinue any product or service without notice, and advise customers to obtain the latest version of relevant information to verify, before placing orders, that information being relied on is current and complete. All products are sold subject to the terms and conditions of sale supplied at the time of order acknowledgment, including those pertaining to warranty, patent infringement, and limitation of liability.

TI warrants performance of its semiconductor products to the specifications applicable at the time of sale in accordance with TI's standard warranty. Testing and other quality control techniques are utilized to the extent TI deems necessary to support this warranty. Specific testing of all parameters of each device is not necessarily performed, except those mandated by government requirements.

Customers are responsible for their applications using TI components.

In order to minimize risks associated with the customer's applications, adequate design and operating safeguards must be provided by the customer to minimize inherent or procedural hazards.

TI assumes no liability for applications assistance or customer product design. TI does not warrant or represent that any license, either express or implied, is granted under any patent right, copyright, mask work right, or other intellectual property right of TI covering or relating to any combination, machine, or process in which such semiconductor products or services might be or are used. TI's publication of information regarding any third party's products or services does not constitute TI's approval, warranty or endorsement thereof.