

Precision current measurements on high-voltage power-supply rails

Scott Hill, Current Sensing Products



Current is a signal that can provide valuable insight into how a system is operating. Under defined conditions, the amount of current required to perform a task is consistent, making the current information a useful indicator to determine if the system is operating within expectations. There are multiple measurement methods and locations where current is measured to evaluate this informative signal.

Low-Side Sensing

One current measurement location is in the return path to ground of a particular load or system. The device requirements for this location are minimal, requiring only an amplifier capable of handling a common-mode signal reaching down to ground. As shown in Figure 1, placing a small current sensing resistor (also called shunt resistor) in series with the system return path to ground develops a voltage across the resistor proportional to the current.

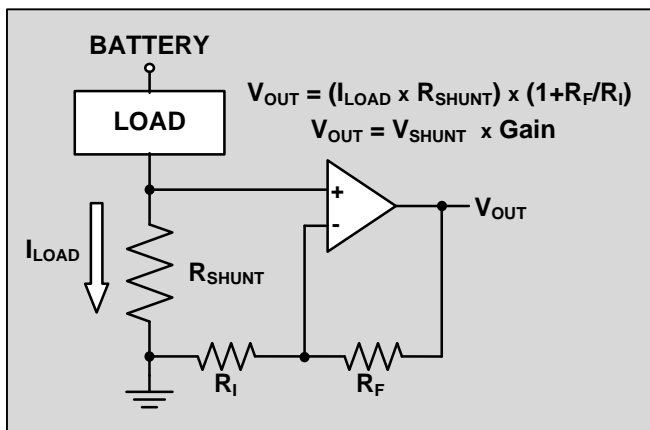

Figure 1. Low-Side Current Sensing

Many types of amplifiers are able to accommodate this low-side capability with an input voltage range down to ground. Standard operational amplifiers, difference amplifiers, instrumentation amplifiers, and current sensing amplifiers are all capable of common-mode input ranges inclusive of ground.

Table 1 provides an overview on how each of these four amplifier types compare for current-sensing applications.

Table 1. Amplifiers for Current Sensing

	$V_{CM} = 0\text{ V}$	$V_{CM} > 0\text{ V}$	Benefit	Disadvantage
Operational amplifier	+	x	Low Cost	Accuracy, Low-Side
Difference amplifier	+	+	High-Side	Low Gain, Cost
Instrumentation amplifier	+	x	Accuracy, High Gain	Low-Side, Cost
Current sense amplifier	+	+	High-Side, High Gain, Accuracy	—

One of the drawbacks to low-side sensing is the loss of the direct connection to the system ground for the load being monitored. As shown in Figure 2, when current passes through the shunt resistor, the voltage developed across the component changes, causing the system reference to deviate from the ground potential of the monitored load. This varying reference connection can be problematic if the system is not able to accommodate the ground potential moving up and down proportionally to the system current.

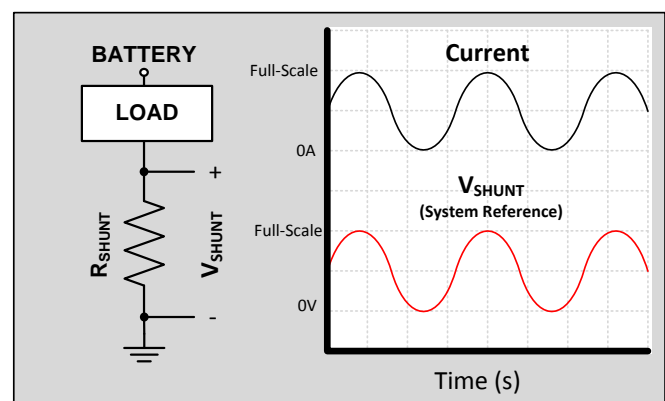

Figure 2. Varying Load Reference

In addition to the varying system ground, some fault conditions can be difficult to detect with a low-side measurement location. If a short-circuit condition results in current flowing through another path to ground other than through the shunt resistor, the event is not detectable by the low-side amplifier.

High-Side Sensing

Measuring current at the high-side of the load, or directly in series with the power rail being monitored and the remainder of the circuit, avoids both the varying system reference and alternate short-circuit path issues of low-side current measurements. The high-side location allows for measuring the entire system current, so any excess current through unintended paths is detected. Moving away from the low-side location eliminates the varying system ground due to the current induced shunt voltage.

A challenge associated with the high-side measurement location is that the amplifier must interface with large input voltage rails, such as high-voltage batteries. A typical signal chain path for measuring current is to amplify the voltage developed across a current sensing resistor, and direct that amplified signal to an analog-to-digital converter (ADC). The input range of an ADC (whether discrete or integrated within a microcontroller) is relatively small compared to the voltage rails being monitored in communication and industrial equipment. Common-mode voltage requirements can exceed 60 V, requiring an amplifier capable of input signals far exceeding the allowable input range for the low-voltage component.

Current sense amplifiers are dedicated amplifiers developed specifically to accommodate these high-voltage input levels, while keeping the lower voltage components following the amplifier within the linear input range and protecting them from overvoltage conditions.

The [INA190](#) current sense amplifier accommodates the requirement of monitoring high-voltage power rails and interfacing with lower voltage components, while being powered by a supply voltage as low as 1.7 V, as shown in [Figure 3](#).

In the event the system is placed into a shutdown or sleep state, low-voltage supplies powering the ADCs, microcontrollers, and signal path amplifiers can potentially be turned off. However, batteries remain connected to the measurement circuitry even if the monitoring amplifiers are powered down. The [INA190](#) features a capacitively coupled input stage that eliminates unnecessary current draw from the battery when disabled, or when the power supply is zero.

In always-on scenarios, the current sense amplifier input circuitry is specifically designed to accommodate the entire input range independent of the device supply voltage. The [INA190](#) can withstand the full 40-V input voltage at the input pins, regardless of whether a supply voltage is present or not, while drawing very little current from the supply, and without being damaged.

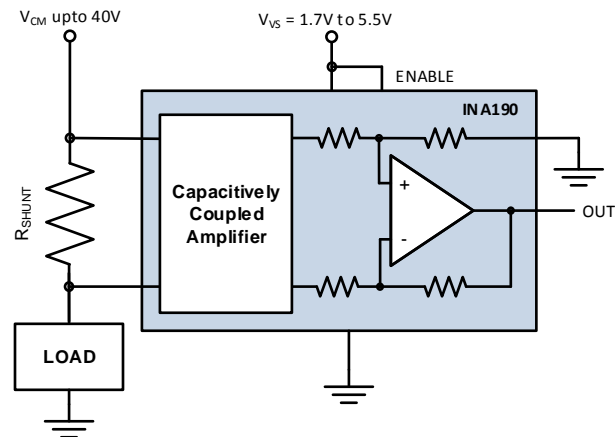

Figure 3. INA190: Dedicated Current-Sensing Amplifier

Alternate Device Recommendations

For applications that need the performance of the [INA190](#) in a smaller package with lower voltage enable thresholds, the [INA191](#) is offered in a small 0.96-mm² chip-scale package. For applications with lower performance requirements, using the [INA199](#) still takes advantage of the benefits of the dedicated current sense amplifier. For higher voltage requirements, the [INA240](#) provides an input common-mode voltage range reaching up to 80 V, and features enhanced PWM rejection circuitry for applications with large input voltage transitions, such as motor control and switching power supplies. The [INA301](#) current sense amplifier features an onboard comparator to perform overcurrent detection on chip.

Table 2. Alternate Device Recommendations

Device	Optimized Parameter	Performance Trade-Off
INA199	Lower Cost	I_Q , I_B , V_{OS} , Gain Error
INA191	Small Size, 1.8 V Enable, Accuracy	Package: WCSP-6
INA240	High V_{CM} : -4 V to +80 V, Bandwidth	I_Q , I_B , Package: TSSOP-8
INA301	Signal Bandwidth, Onboard Comparator	I_Q , I_B , Package: MSOP-8

Table 3. Related TI Tech Notes

SBOA160	High Precision, Low-Drift In-Line Motor Current Measurements
SBOA162	Measuring Current To Detect Out-of-Range Conditions
SBOA163	High-Side Motor Current Monitoring for Over-Current Protection
SBOA167	Integrating The Current Sensing Signal Path

IMPORTANT NOTICE AND DISCLAIMER

TI PROVIDES TECHNICAL AND RELIABILITY DATA (INCLUDING DATASHEETS), DESIGN RESOURCES (INCLUDING REFERENCE DESIGNS), APPLICATION OR OTHER DESIGN ADVICE, WEB TOOLS, SAFETY INFORMATION, AND OTHER RESOURCES "AS IS" AND WITH ALL FAULTS, AND DISCLAIMS ALL WARRANTIES, EXPRESS AND IMPLIED, INCLUDING WITHOUT LIMITATION ANY IMPLIED WARRANTIES OF MERCHANTABILITY, FITNESS FOR A PARTICULAR PURPOSE OR NON-INFRINGEMENT OF THIRD PARTY INTELLECTUAL PROPERTY RIGHTS.

These resources are intended for skilled developers designing with TI products. You are solely responsible for (1) selecting the appropriate TI products for your application, (2) designing, validating and testing your application, and (3) ensuring your application meets applicable standards, and any other safety, security, or other requirements. These resources are subject to change without notice. TI grants you permission to use these resources only for development of an application that uses the TI products described in the resource. Other reproduction and display of these resources is prohibited. No license is granted to any other TI intellectual property right or to any third party intellectual property right. TI disclaims responsibility for, and you will fully indemnify TI and its representatives against, any claims, damages, costs, losses, and liabilities arising out of your use of these resources.

TI's products are provided subject to TI's Terms of Sale (www.ti.com/legal/termsofsale.html) or other applicable terms available either on ti.com or provided in conjunction with such TI products. TI's provision of these resources does not expand or otherwise alter TI's applicable warranties or warranty disclaimers for TI products.

Mailing Address: Texas Instruments, Post Office Box 655303, Dallas, Texas 75265
Copyright © 2019, Texas Instruments Incorporated