

# Analog Engineer's Circuit

## Photodiode Amplifier Circuit



### Design Goals

Input		Output		BW	Supply		
$I_{iMin}$	$I_{iMax}$	$V_{oMin}$	$V_{oMax}$	$f_p$	$V_{cc}$	$V_{ee}$	$V_{ref}$
0 A	2.4 $\mu$ A	100 mV	4.9 V	20 kHz	5 V	0 V	0.1 V

### Design Description

This circuit consists of an op amp configured as a transimpedance amplifier for amplifying the light-dependent current of a photodiode.

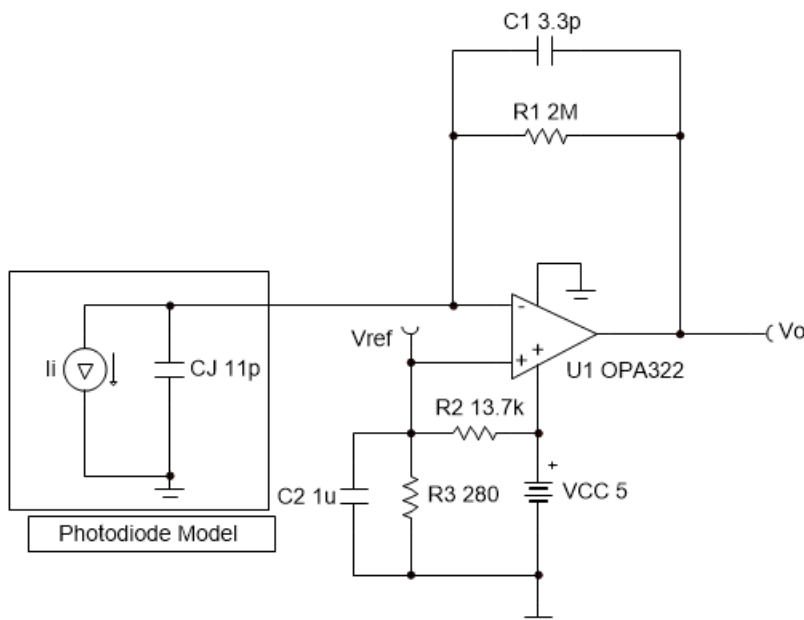

Copyright © 2018, Texas Instruments Incorporated

### Design Notes

1. A bias voltage ( $V_{ref}$ ) prevents the output from saturating at the negative power supply rail when the input current is 0 A.
2. Use a JFET or CMOS input op amp with low bias current to reduce DC errors.
3. Set output range based on linear output swing (see  $A_{ol}$  specification).

## Design Steps

1. Select the gain resistor.

$$R_1 = \frac{V_{oMax} - V_{oMin}}{I_{iMax}} = \frac{4.9V - 0.1V}{2.4\mu A} = 2M\Omega$$

2. Select the feedback capacitor to meet the circuit bandwidth.

$$C_1 \leq \frac{1}{2 \times \pi \times R_1 \times f_p}$$

$$C_1 \leq \frac{1}{2 \times \pi \times 2M\Omega \times 20kHz} \leq 3.97pF \approx 3.3pF \text{ (Standard Value)}$$

3. Calculate the necessary op amp gain bandwidth (GBW) for the circuit to be stable.

$$GBW > \frac{C_i + C_1}{2 \times \pi \times R_1 \times C_1^2} > \frac{20pF + 3.3pF}{2 \times \pi \times 2M\Omega \times (3.3pF)^2} > 170kHz$$

where  $C_i = C_j + C_d + C_{cm} = 11pF + 5pF + 4pF = 20pF$  given

- $C_j$ : Junction capacitance of photodiode
- $C_d$ : Differential input capacitance of the amplifier
- $C_{cm}$ : Common-mode input capacitance of the inverting input

4. Calculate the bias network for a 0.1 V bias voltage.

$$R_2 = \frac{V_{cc} - V_{ref}}{V_{ref}} \times R_3$$

$$R_2 = \frac{5V - 0.1V}{0.1V} \times R_3$$

$$R_2 = 49 \times R_3$$

Closest 1% resistor values that yield this relationship are

$$R_2 = 13.7k\Omega \text{ and } R_3 = 280\Omega$$

5. Select  $C_2$  to be 1  $\mu F$  to filter the  $V_{ref}$  voltage. The resulting cutoff frequency is:

$$f_p = \frac{1}{2 \times \pi \times C_2 \times (R_2 \parallel R_3)} = \frac{1}{2 \times \pi \times 1 \mu F \times (13.7k \parallel 280)} = 580Hz$$

## Design Simulations

### DC Simulation Results

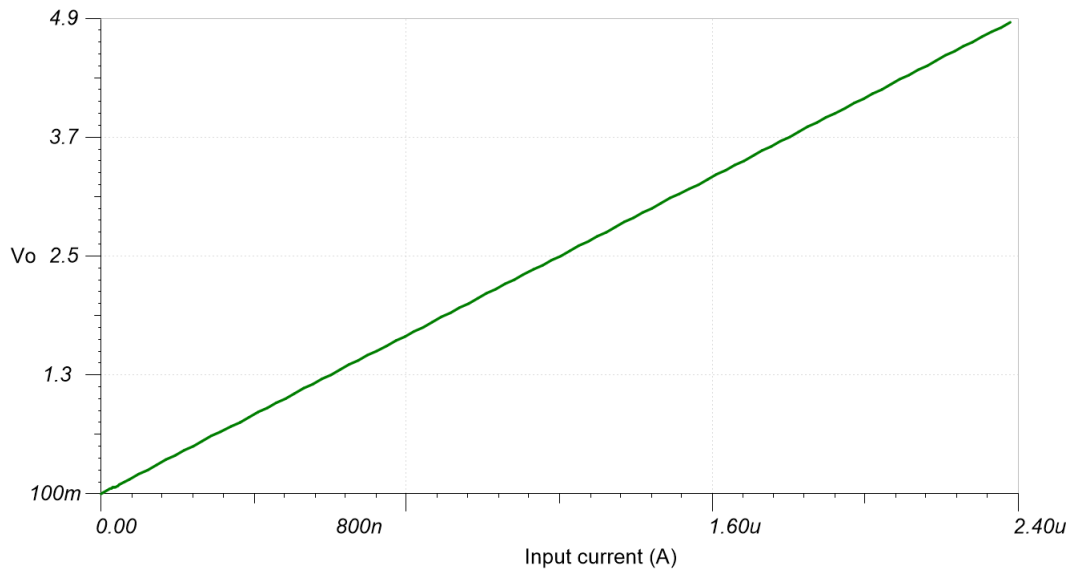

### AC Simulation Results

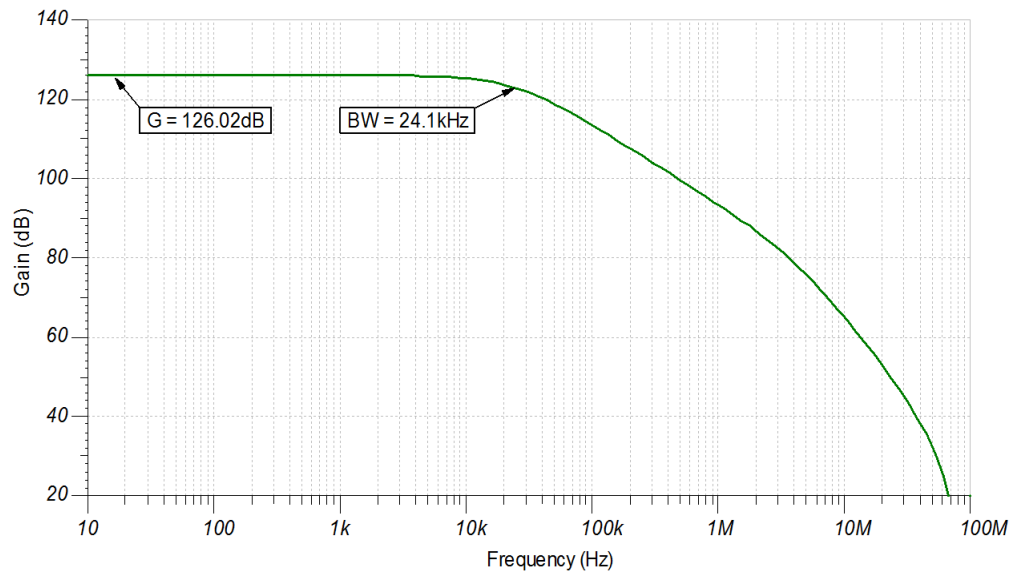

## Design References

See [Analog Engineer's Circuit Cookbooks](#) for TI's comprehensive circuit library.

See the circuit SPICE simulation file [SBOC517](#).

See [TIPD176](#).

## Design Featured Op Amp

OPA322	
$V_{cc}$	1.8 V to 5.5 V
$V_{inCM}$	Rail-to-rail
$V_{out}$	Rail-to-rail
$V_{os}$	0.5 mV
$I_q$	1.6 mA/Ch
$I_b$	0.2 pA
UGBW	20 MHz
SR	10 V/ $\mu$ s
#Channels	1, 2, and 4
<a href="#">OPA322</a>	

## Design Alternate Op Amp

LMP7721	
$V_{cc}$	1.8 V to 5.5 V
$V_{inCM}$	$V_{ee}$ to ( $V_{cc} - 1$ V)
$V_{out}$	Rail-to-rail
$V_{os}$	26 $\mu$ V
$I_q$	1.3 mA/Ch
$I_b$	3 fA
UGBW	17 MHz
SR	10.43 V/ $\mu$ s
#Channels	1
<a href="#">LMP7721</a>	

## Revision History

NOTE: Page numbers for previous revisions may differ from page numbers in the current version.

Changes from February 1, 2018 to February 4, 2019	Page
<ul style="list-style-type: none"> <li>Downdscale the title and changed title role to 'Amplifiers'. Added links to circuit cookbook landing page and SPICE simulation file.....</li> </ul>	1

## IMPORTANT NOTICE AND DISCLAIMER

TI PROVIDES TECHNICAL AND RELIABILITY DATA (INCLUDING DATA SHEETS), DESIGN RESOURCES (INCLUDING REFERENCE DESIGNS), APPLICATION OR OTHER DESIGN ADVICE, WEB TOOLS, SAFETY INFORMATION, AND OTHER RESOURCES "AS IS" AND WITH ALL FAULTS, AND DISCLAIMS ALL WARRANTIES, EXPRESS AND IMPLIED, INCLUDING WITHOUT LIMITATION ANY IMPLIED WARRANTIES OF MERCHANTABILITY, FITNESS FOR A PARTICULAR PURPOSE OR NON-INFRINGEMENT OF THIRD PARTY INTELLECTUAL PROPERTY RIGHTS.

These resources are intended for skilled developers designing with TI products. You are solely responsible for (1) selecting the appropriate TI products for your application, (2) designing, validating and testing your application, and (3) ensuring your application meets applicable standards, and any other safety, security, regulatory or other requirements.

These resources are subject to change without notice. TI grants you permission to use these resources only for development of an application that uses the TI products described in the resource. Other reproduction and display of these resources is prohibited. No license is granted to any other TI intellectual property right or to any third party intellectual property right. TI disclaims responsibility for, and you will fully indemnify TI and its representatives against, any claims, damages, costs, losses, and liabilities arising out of your use of these resources.

TI's products are provided subject to [TI's Terms of Sale](#) or other applicable terms available either on [ti.com](https://www.ti.com) or provided in conjunction with such TI products. TI's provision of these resources does not expand or otherwise alter TI's applicable warranties or warranty disclaimers for TI products.

TI objects to and rejects any additional or different terms you may have proposed.

Mailing Address: Texas Instruments, Post Office Box 655303, Dallas, Texas 75265  
Copyright © 2023, Texas Instruments Incorporated