

AC coupled (HPF) inverting amplifier circuit

Design Goals

Input		Output		Supply		
V_{iMin}	V_{iMax}	V_{oMin}	V_{oMax}	V_{cc}	V_{ee}	V_{ref}
-240mV	240mV	0.1V	4.9V	5V	0V	5V

Design Description

This circuit amplifies an AC signal and shifts the output signal so that it is centered at half the power supply voltage. Note that the input signal has zero DC offset so it swings above and below ground. The key benefit of this circuit is that it accepts signals which swing below ground even though the amplifier does not have a negative power supply.

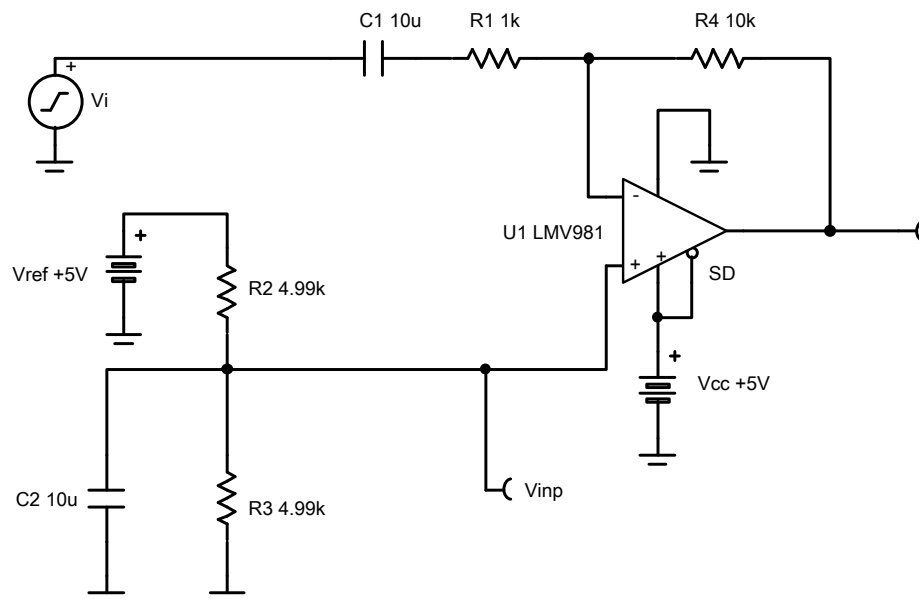

Design Notes

1. R_1 sets the AC input impedance. R_4 loads the op amp output.
2. Use low feedback resistances to reduce noise and minimize stability concerns.
3. Set the output range based on linear output swing (see A_{ol} specification).
4. The cutoff frequency of the circuit is dependent on the gain bandwidth product (GBP) of the amplifier. Additional filtering can be accomplished by adding a capacitor in parallel to R_4 . Adding a capacitor in parallel with R_4 will also improve stability of the circuit if high-value resistors are used.

Design Steps

1. Select R_1 and R_4 to set the AC voltage gain.

$$R_1 = 1 \text{ k}\Omega \text{ (Standard Value)}$$

$$R_4 = R_1 \times |G_{ac}| = 1 \text{ k}\Omega \times |-10 \frac{V}{V}| = 10 \text{ k}\Omega \text{ (Standard Value)}$$

2. Select R_2 and R_3 to set the DC output voltage to 2.5V.

$$R_3 = 4.99 \text{ k}\Omega \text{ (Standard Value)}$$

$$R_2 = \frac{R_3 \times V_{ref}}{V_{DC}} - R_3 = \frac{4.99 \text{ k}\Omega \times 5V}{2.5V} - 4.99 \text{ k}\Omega = 4.99 \text{ k}\Omega$$

3. Choose a value for the lower cutoff frequency, f_l , then calculate C_1 .

$$f_l = 16 \text{ Hz}$$

$$C_1 = \frac{1}{2 \times \pi \times R_1 \times f_l} = \frac{1}{2 \times \pi \times 1 \text{ k}\Omega \times 16 \text{ Hz}} = 9.94 \mu\text{F} \approx 10 \mu\text{F} \text{ (Standard Value)}$$

4. Choose a value for f_{div} , then calculate C_2 .

$$f_{div} = 6.4 \text{ Hz}$$

$$R_{div} = \frac{R_2 \times R_3}{R_2 + R_3} = \frac{4.99 \text{ k}\Omega \times 4.99 \text{ k}\Omega}{4.99 \text{ k}\Omega + 4.99 \text{ k}\Omega} = 2.495 \text{ k}\Omega$$

$$C_2 = \frac{1}{2 \times \pi \times R_{div} \times f_{div}} = \frac{1}{2 \times \pi \times 2.495 \text{ k}\Omega \times 6.4 \text{ Hz}} = 9.96 \mu\text{F} \approx 10 \mu\text{F} \text{ (Standard Value)}$$

5. The upper cutoff frequency, f_h , is set by the noise gain of this circuit and the gain bandwidth (GBW) of the device (LMV981).

$$GBW = 1.5 \text{ MHz}$$

$$G_{noise} = 1 + \frac{R_4}{R_1} = 1 + \frac{10 \text{ k}\Omega}{1 \text{ k}\Omega} = 11 \frac{V}{V}$$

$$f_h = \frac{GBW}{G_{noise}} = \frac{1.5 \text{ MHz}}{11 \frac{V}{V}} = 136.3 \text{ kHz}$$

Design Simulations

AC Simulation Results

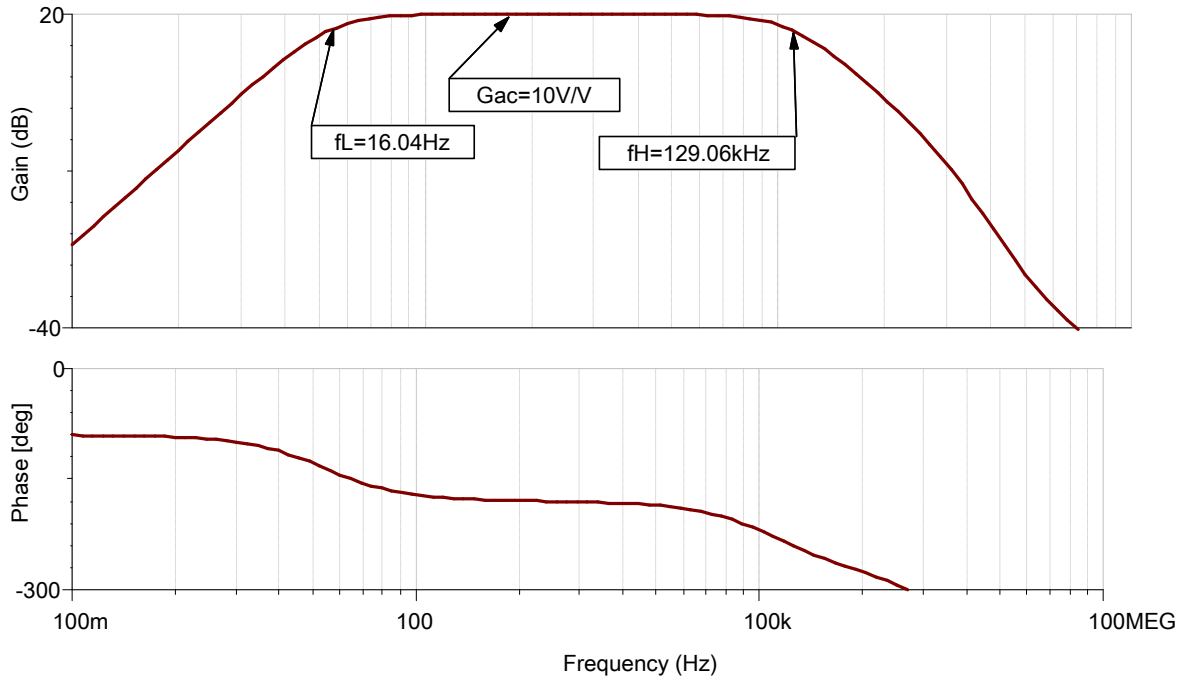

Transient Simulation Results

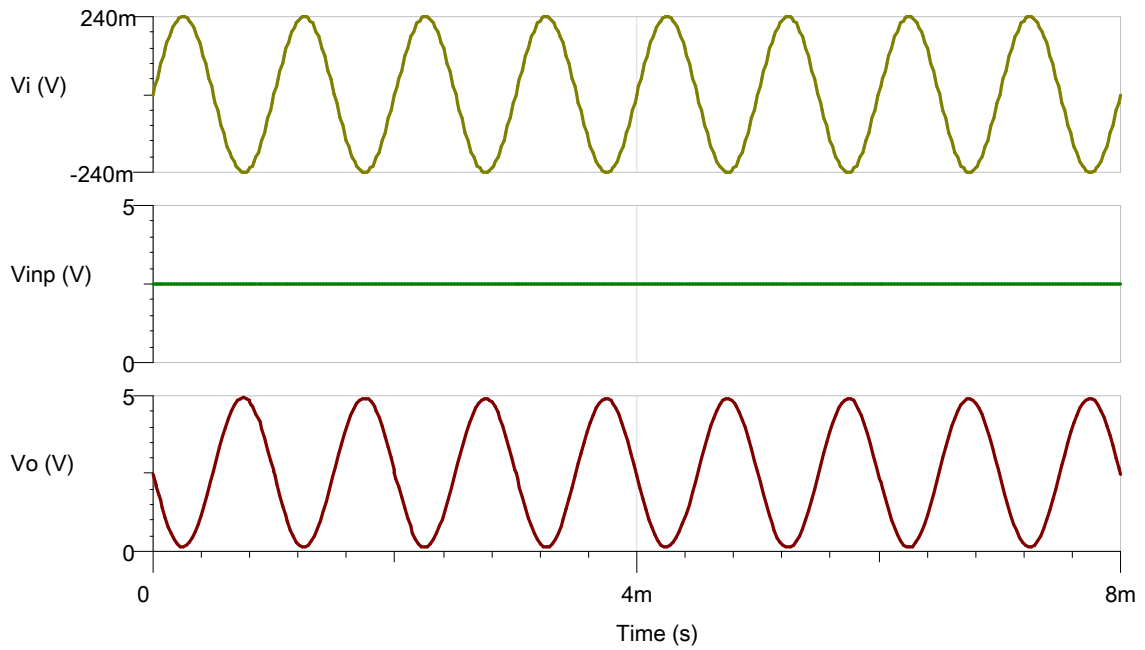

Design References

See [Analog Engineer's Circuit Cookbooks](#) for TI's comprehensive circuit library.

See circuit SPICE simulation file [SBOC504](#).

See TIPD185, www.ti.com/tool/tipd185.

Design Featured Op Amp

LMV981	
V_{cc}	1.8V to 5V
V_{inCM}	Rail-to-rail
V_{out}	Rail-to-rail
V_{os}	1mV
I_q	116 μ A
I_b	14nA
UGBW	1.5MHz
SR	0.42V/ μ s
#Channels	1, 2
www.ti.com/product/lmv981-n	

Design Alternate Op Amp

LMV771	
V_{cc}	2.7V to 5V
V_{inCM}	V_{ee} to $(V_{cc}-0.9V)$
V_{out}	Rail-to-rail
V_{os}	0.25mV
I_q	600 μ A
I_b	-0.23pA
UGBW	3.5MHz
SR	1.5V/ μ s
#Channels	1, 2
www.ti.com/product/lmv771	

Revision History

Revision	Date	Change
A	January 2019	Downscale the title and changed title role to 'Amplifiers'. Added link to circuit cookbook landing page.

IMPORTANT NOTICE AND DISCLAIMER

TI PROVIDES TECHNICAL AND RELIABILITY DATA (INCLUDING DATA SHEETS), DESIGN RESOURCES (INCLUDING REFERENCE DESIGNS), APPLICATION OR OTHER DESIGN ADVICE, WEB TOOLS, SAFETY INFORMATION, AND OTHER RESOURCES "AS IS" AND WITH ALL FAULTS, AND DISCLAIMS ALL WARRANTIES, EXPRESS AND IMPLIED, INCLUDING WITHOUT LIMITATION ANY IMPLIED WARRANTIES OF MERCHANTABILITY, FITNESS FOR A PARTICULAR PURPOSE OR NON-INFRINGEMENT OF THIRD PARTY INTELLECTUAL PROPERTY RIGHTS.

These resources are intended for skilled developers designing with TI products. You are solely responsible for (1) selecting the appropriate TI products for your application, (2) designing, validating and testing your application, and (3) ensuring your application meets applicable standards, and any other safety, security, regulatory or other requirements.

These resources are subject to change without notice. TI grants you permission to use these resources only for development of an application that uses the TI products described in the resource. Other reproduction and display of these resources is prohibited. No license is granted to any other TI intellectual property right or to any third party intellectual property right. TI disclaims responsibility for, and you will fully indemnify TI and its representatives against, any claims, damages, costs, losses, and liabilities arising out of your use of these resources.

TI's products are provided subject to [TI's Terms of Sale](#) or other applicable terms available either on [ti.com](#) or provided in conjunction with such TI products. TI's provision of these resources does not expand or otherwise alter TI's applicable warranties or warranty disclaimers for TI products.

TI objects to and rejects any additional or different terms you may have proposed.

Mailing Address: Texas Instruments, Post Office Box 655303, Dallas, Texas 75265
Copyright © 2021, Texas Instruments Incorporated