

Dual-supply, discrete, programmable gain amplifier circuit

Design Goals

Input		Output		Supply	
V_{iMin}	V_{iMax}	V_{oMin}	V_{oMax}	V_{cc}	V_{ee}
-1.25V	+1.25V	-2.4V	+2.4V	+2.5V	-2.5V

Gain	Cutoff Frequency
6dB (2V/V) to 60dB (1000 V/V)	7kHz

Design Description

This circuit provides programmable, non-inverting gains ranging from 6dB (2V/V) to 60dB (1000V/V) using a variable input resistance. The design maintains the same cutoff frequency over the gain range.

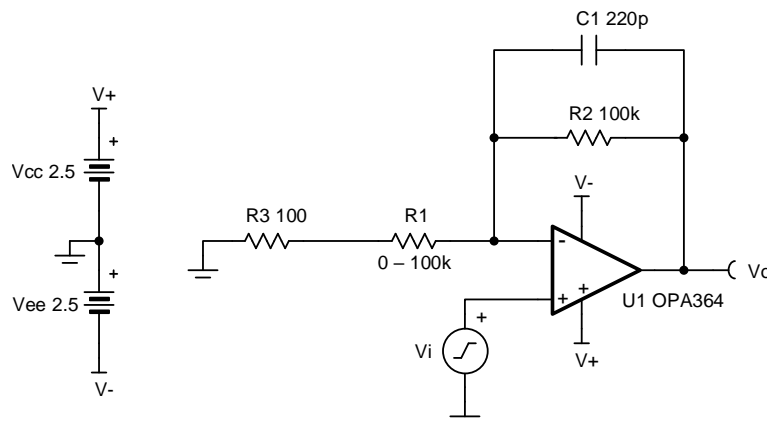

Design Notes

1. Choose a digital potentiometer, such as TPL0102 for R_1 to design a low-cost digital programmable gain amplifier.
2. R_3 sets the maximum gain when R_1 approaches 0Ω .
3. A feedback capacitor limits the bandwidth and prevent stability issues.
4. Stability should be evaluated across the selected gain range. The minimum gain setting will likely be most sensitive to stability issues.
5. Some digital potentiometers can vary in absolute value by as much as +/-20% so gain calibration may be necessary.

Design Steps

1. Choose R_2 and R_3 , to set the maximum gain when R_1 approaches 0:

$$G_{\max} = 1 + \frac{R_2}{R_3}$$

$$G_{\max} - 1 = \frac{R_2}{R_3} \rightarrow R_2 = (G_{\max} - 1) \times R_3$$

$$\text{Set } R_3 = 100 \Omega$$

$$R_2 = (1000 \frac{V}{V} - 1) \times 100 = 99 \text{ k}\Omega \rightarrow R_2 = 100 \text{ k}\Omega \text{ (Standard value)}$$

2. Choose the potentiometer maximum value to set the minimum gain:

$$G_{\min} = 1 + \frac{R_2}{R_{1,\max} + R_3}$$

$$G_{\min} - 1 = \frac{R_2}{R_{1,\max} + R_3}$$

$$R_{1,\max} + R_3 = \frac{R_2}{G_{\min} - 1}$$

$$R_{1,\max} = \frac{R_2}{G_{\min} - 1} - R_3 = \frac{100\text{k}\Omega}{2 - 1} - 100\Omega = 99.9\text{k}\Omega \rightarrow R_{1,\max} = 100\text{k}\Omega \text{ (Standard value)}$$

$$R_{1,\min} = 0\Omega \text{ (Wiper resistance, typically } 25\Omega, \text{ will introduce some error)}$$

3. Choose the bandwidth with a feedback capacitor:

$$f_c = \frac{\text{GBW}}{G_{\max}} = \frac{7\text{MHz}}{1000 \frac{V}{V}} = 7\text{kHz}$$

$$f_c = 7\text{kHz} \rightarrow C_1 = \frac{1}{2\pi \times R_2 \times f_c} = 227\text{pF} \rightarrow C_1 = 220\text{pF} \text{ (Standard Value)}$$

4. Check for stability at minimum gain ($2V/V$), which is when $R_1=100\text{k}\Omega$. To satisfy the requirement f_c (circuit bandwidth) must be less than f_{zero} (zero created by the resistive feedback network and the differential and common-mode input capacitances).

$$f_c = \frac{1}{2\pi \times C_1 \times R_2} = 7 \text{ kHz}$$

$$f_{\text{zero}} = \frac{1}{2\pi \times (C_{\text{cm}} + C_{\text{diff}}) \times (R_2 \parallel R_1)} = \frac{1}{2 \times \pi \times (3 \text{ pF} + 2 \text{ pF}) \times \left(\frac{100 \text{ k}\Omega \times 100 \text{ k}\Omega}{100 \text{ k}\Omega + 100 \text{ k}\Omega} \right)}$$

$$f_{\text{zero}} = 637 \text{ kHz}$$

$$7 \text{ kHz} < 637 \text{ kHz} \rightarrow f_c < f_{\text{zero}}$$

Design Simulations

Transient Simulation Results

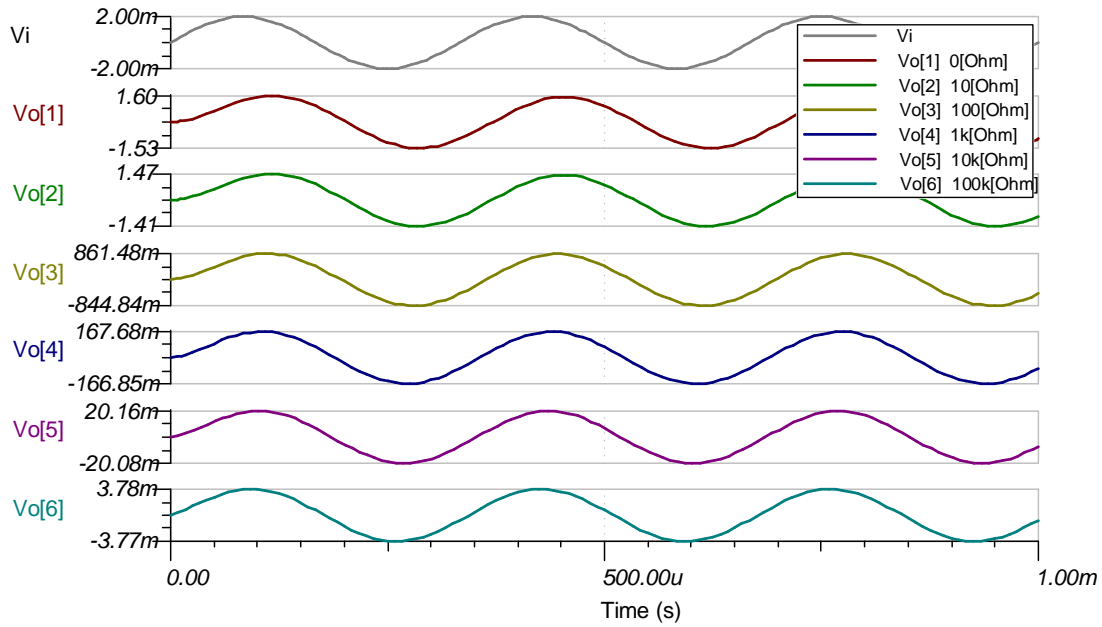

AC Simulation Results

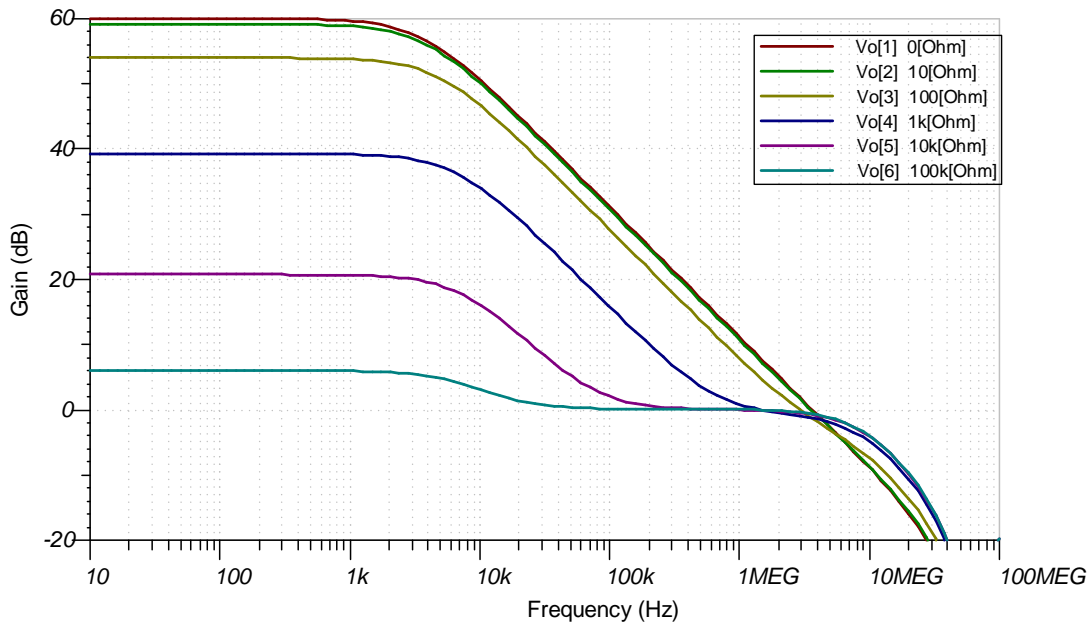

References:

1. [Analog Engineer's Circuit Cookbooks](#)
2. SPICE Simulation File [SBOC521](#)
3. TI Precision Designs [TIPD204](#)
4. [TI Precision Labs](#)

Design Featured Op Amp

OPA364	
V_{ss}	1.8V to 5.5V
V_{inCM}	Rail-to-rail
V_{out}	Rail-to-rail
V_{os}	1mV
I_q	1.1mA
I_b	1pA
UGBW	7MHz
SR	5V/ μ s
#Channels	1, 2, 4
www.ti.com/product/opa364	

Design Alternate Op Amp

OPA376	
V_{ss}	2.2V to 5.5V
V_{inCM}	Rail-to-rail
V_{out}	Rail-to-rail
V_{os}	5 μ V
I_q	760 μ A
I_b	0.2pA
UGBW	5.5MHz
SR	2V/ μ s
#Channels	1, 2, 4
www.ti.com/product/opa376	

IMPORTANT NOTICE AND DISCLAIMER

TI PROVIDES TECHNICAL AND RELIABILITY DATA (INCLUDING DATASHEETS), DESIGN RESOURCES (INCLUDING REFERENCE DESIGNS), APPLICATION OR OTHER DESIGN ADVICE, WEB TOOLS, SAFETY INFORMATION, AND OTHER RESOURCES "AS IS" AND WITH ALL FAULTS, AND DISCLAIMS ALL WARRANTIES, EXPRESS AND IMPLIED, INCLUDING WITHOUT LIMITATION ANY IMPLIED WARRANTIES OF MERCHANTABILITY, FITNESS FOR A PARTICULAR PURPOSE OR NON-INFRINGEMENT OF THIRD PARTY INTELLECTUAL PROPERTY RIGHTS.

These resources are intended for skilled developers designing with TI products. You are solely responsible for (1) selecting the appropriate TI products for your application, (2) designing, validating and testing your application, and (3) ensuring your application meets applicable standards, and any other safety, security, or other requirements. These resources are subject to change without notice. TI grants you permission to use these resources only for development of an application that uses the TI products described in the resource. Other reproduction and display of these resources is prohibited. No license is granted to any other TI intellectual property right or to any third party intellectual property right. TI disclaims responsibility for, and you will fully indemnify TI and its representatives against, any claims, damages, costs, losses, and liabilities arising out of your use of these resources.

TI's products are provided subject to TI's Terms of Sale (www.ti.com/legal/termsofsale.html) or other applicable terms available either on ti.com or provided in conjunction with such TI products. TI's provision of these resources does not expand or otherwise alter TI's applicable warranties or warranty disclaimers for TI products.

Mailing Address: Texas Instruments, Post Office Box 655303, Dallas, Texas 75265
Copyright © 2019, Texas Instruments Incorporated